

VIDEO SYNCHRONOUS DETECTOR

■ GENERAL DESCRIPTION

The **NJM2230** discriminate existence and fineness of video signal. It is applicable VCR, TV, Video camera, Hi-Fi VCR, on screen display and others.

■ FEATURES

- Operating Voltage (+4.7V to + 13V)
- Package Outline DMP8
- Bipolar Technology

■ RECOMMENDED OPERATING CONDITION

- Operating Voltage V⁺=4.75 to 10V

■ APPLICATION

- Video camera, other video equipment

■ PIN CONFIGURATION

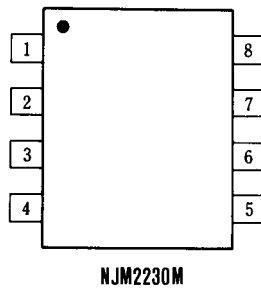

PIN FUNCTION

1. M.M Time Constant Set
2. SYNC Input (Comp. H, V SYNC)
3. SYNC Output
4. SSG SYNC Input
5. GND
6. SYNC DET, Judgement Control
7. M.M Smoothing
8. V⁺ 5~10V

■ PACKAGE OUTLINE

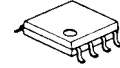

NJM2230M

NJM2230

■ ABSOLUTE MAXIMUM RATINGS

(Ta=25°C)

PARAMETER	SYMBOL	RATINGS	UNIT
Supply Voltage	V ⁺	12	V
Power Dissipation	P _D	(DMP8) 300	mW
Operating Temperature Range	T _{opr}	-40 to +85	°C
Storage Temperature Range	T _{stg}	-40 to +125	°C

■ ELECTRICAL CHARACTERISTICS

(V⁺=5V, Ta=25°C)

PARAMETER	SYMBOL	TEST CONDITION	MIN.	TYP.	MAX.	UNIT
Operating Current	I _{CC}		-	8	11	mA
Schmitt Circuit CAP Voltage	H side	V _{CAP-H} (Note 1)	2.07	2.22	2.37	V
	L side	V _{CAP-L} (Note 1)	1.57	1.72	1.87	V
Schmitt Circuit LOCK Voltage	H side	V _{LOCK-H} (Note 1)	2.53	2.68	2.83	V
	L side	V _{LOCK-L} (Note 1)	1.25	1.40	1.55	V
Mono-Multi Output Width	W _{MM}	(Note 2)	-	25	-	μsec
Input Threshold Level	2P	V _{TH-2}	1.0	1.5	2.0	V
	4P	V _{TH-4}	1.0	1.5	2.0	V
	6P	V _{TH-6}	-	0.8	1.4	V
Output Voltage Pin 7	H side	V _{7-H}	4.9	5.0	-	V
	L side	V _{7-L}	-	0.1	0.3	V
Output Voltage Pin 6	H side	V _{6-H}	3.6	4.0	-	V
	L side	V _{6-L}	-	-	0.1	V
Output Voltage Pin 3	H side	V _{3-H}	4.9	5.0	-	V
	L side	V _{3-L}	-	0.1	0.3	V
M. M Smoothed D.C. Voltage	V ₈ (V ₇)	Pin 2=2V	2.9	3.2	3.5	V

(Note 1)

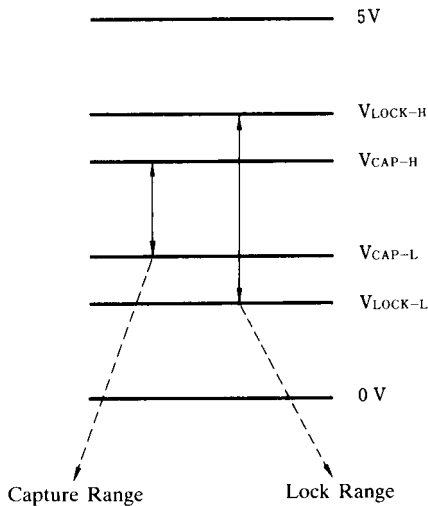

ITEM	V_{CAP-L}	V_{LOCK-H}	V_{CAP-H}	V_{LOCK-L}
Pin 7 Voltage	0	→ 5	→ 0	
Pin 6 Voltage	L	→ H	→ L	→ H → L

Measure Pin 7 Voltage at a moment when Pin 6 output voltage turns state.

(Note 2)

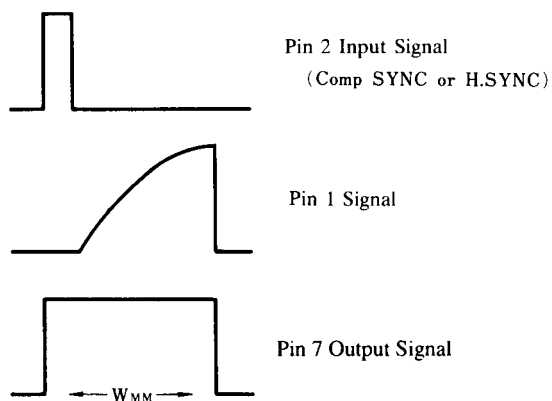

Adjust Pin 7 DC Voltage to 2V (at $V^+=5V$) by varying Pin 1 outer resistor, and test Pin7 output pulse width after taking off Pin7 outer capacitor.

NJM2230

■ TEST CIRCUIT

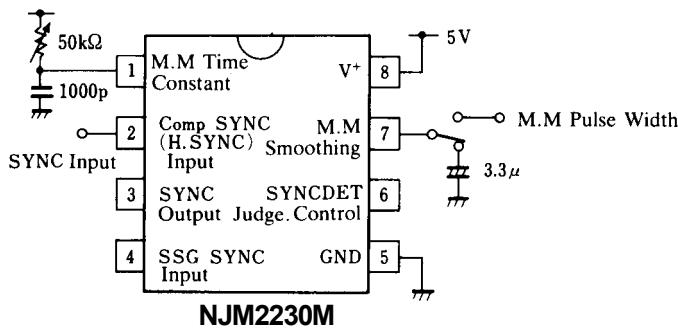

■ OPERATIVE PRINCIPLE

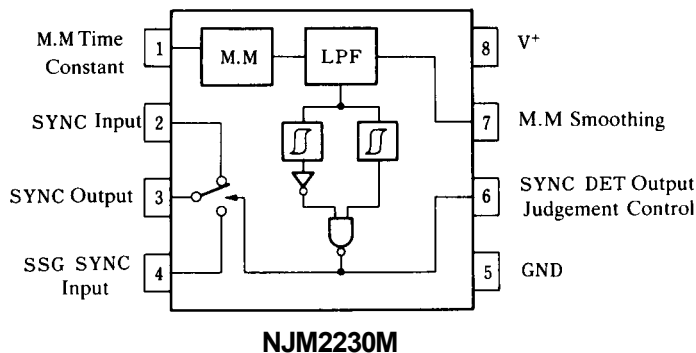

- M. M: Varies duty ratio of output signal depended on input synchronous signal condition (irregular, on, signal)
- LPF: Converts M. M. output signal to DC level. The more larger the duty ratio is, DC level is clamped at $V^+/2+0.7$ (V).
- Comparator: Outputs discriminating signal of input signal by DC level of LPF output. Stabilized output signal can be obtained due to that the hysteresis is given to the output.
- Switch: Makes exchanging operation of SYNC Input and SSG SYNC Input signal by discriminating signal from comparator or Pin 6 signal of SYNC DET Output Judgement Control.

■ TERMINAL FUNCTION

PIN NO.	EXPLANATION
1	Connect resistor and capacitor for M. M. time constant. (Value of R, C is changed by a kind of Pin 2 SYNC Input signal.)
2	Input synchronous signal (Comp SYNC, H. SYNC or V. SYNC) separated from video signal.
3	It outputs Pin 2 or Pin 4 signal by Pin 2 signal condition. <ul style="list-style-type: none"> ● Pin 2 input signal; normal → Output Pin 2 input signal. ● Pin 2 input signal; abnormal → Output Pin 4 input signal.
4	Input artificial synchronous signal generated by SSG (Sync. Signal Generator).
5	GND
6	Input DC voltage (H or L state) by Pin 2 signal condition. When outer SW is turned to 1, Pin 2 input signal is forced to flow out from Pin 3. <ul style="list-style-type: none"> ● Pin 2 input signal; normal → H state ● Pin 2 input signal; abnormal → L state
7	Connect capacitor for smoothing M. M. (Value depends on Pin 2 input Signal). Adjust Pin 1 attached volume to the level that Pin 8 voltage becomes 2V ($V^+ = 5V$) with Pin 2 signal. If $V^+ > 5V$, then $V_7 = 2/5V^+$ (V)
8	V^+ : 5 to 10V

(Note) In some application, it happens that still, search or tracking is large off the point and unordinary SYNC of SYNC occurs. If it is not desirable, you can do in SYNC condition by using Pin 6 as control input terminal. Also recommend sensitivity adjustment of outer device change, by it error detection of unordinary SYNC will lapse. It makes volume to low value, in other word it makes time constant of M. M. to low value. In this case synchronous peak voltage at Pin 7 becomes lower and so makes to 2V ($V^+ = 5V$) by putting resistor in to V^+ . (Adjust to 2V by Pin 1 resistor attached.)

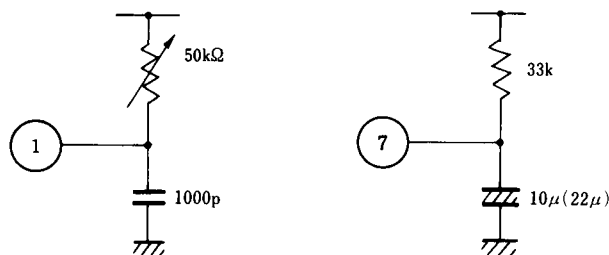

NJM2230

■ TYPICAL CHARACTERISTICS

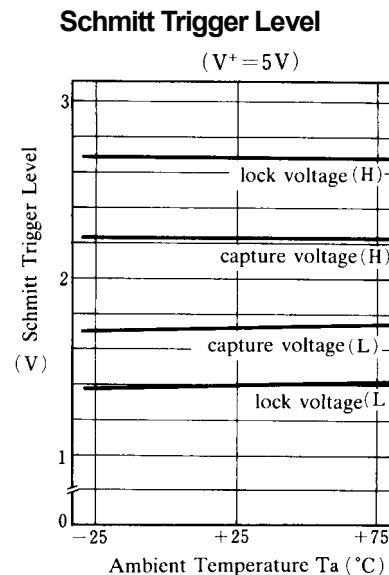
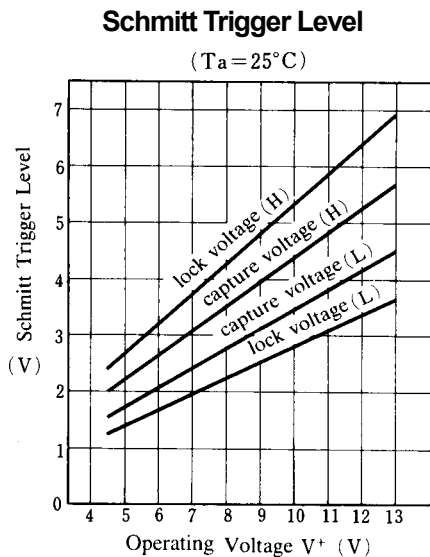
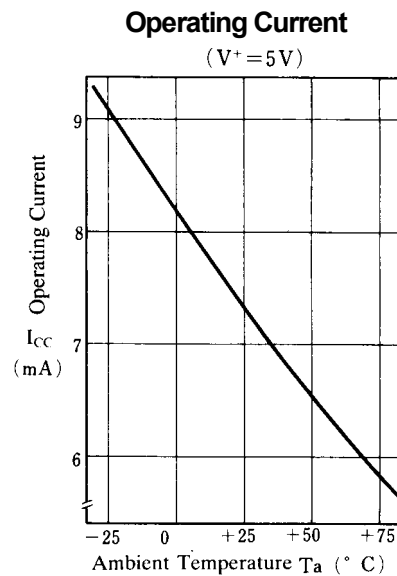
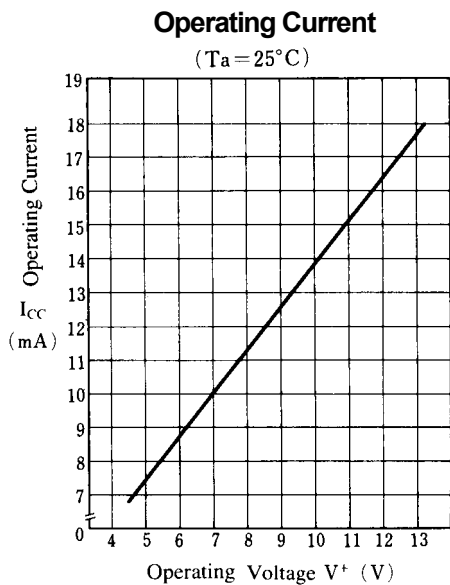

M. M Smoothed DC Voltage
(Carbon film resistor-polyster film Capacitor)

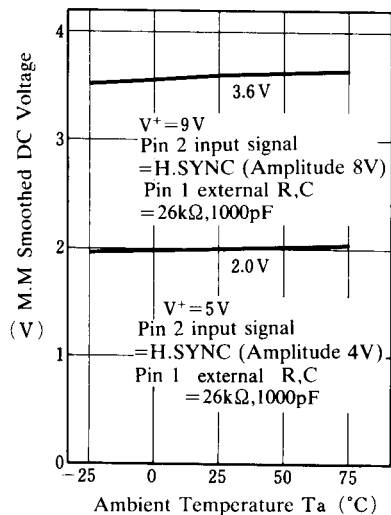

M. M Smoothed DC Voltage
(Metal film resistor-polyster film Capacitor)

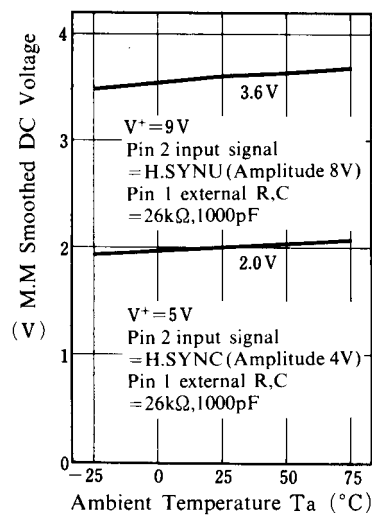



[CAUTION]

The specifications on this databook are only given for information, without any guarantee as regards either mistakes or omissions. The application circuits in this databook are described only to show representative usages of the product and not intended for the guarantee or permission of any right including the industrial rights.

Looking for pricing, stock, or lifecycle information?

Click below to explore more details on WIN SOURCE:

-  [View NJM2230M-TE1 on WIN SOURCE](#)
-  [NJR Corporation/NJRC Information](#)

Optimize Your Supply Chain with WIN SOURCE Solutions

-  Global Sourcing Solution
-  Obsolete Management
-  Cost Control Management
-  Shortage Management
-  Alternative Solution
-  Excess Inventory Management