



THE DATASHEET OF NE556N-E4



FEATURES

- Two Precision Timing Circuits Per Package
- Astable or Monostable Operation
- TTL-Compatible Output Can Sink or Source up to 150 mA
- Active Pullup or Pulldown
- Designed to Be Interchangeable With Signetics NE556, SA556, and SE556

APPLICATIONS

- Precision Timers From Microseconds to Hours
- Pulse-Shaping Circuits
- Missing-Pulse Detectors
- Tone-Burst Generators
- Pulse-Width Modulators
- Pulse-Position Modulators
- Sequential Timers
- Pulse Generators
- Frequency Dividers
- Application Timers
- Industrial Controls
- Touch-Tone Encoders

DESCRIPTION/ORDERING INFORMATION

These devices provide two independent timing circuits of the NA555, NE555, SA555, or SE555 type in each package. These circuits can be operated in the astable or the monostable mode with external resistor-capacitor (RC) timing control. The basic timing provided by the RC time constant can be controlled actively by modulating the bias of the control-voltage input.

The threshold (THRES) and trigger (TRIG) levels normally are two-thirds and one-third, respectively, of V_{CC} . These levels can be altered by using the control voltage (CONT) terminal. When the trigger input falls below trigger level, the flip-flop is set and the output goes high. If the trigger input is above the trigger level and the threshold input is above the threshold level, the flip-flop is reset, and the output is low. The reset (RESET) input can override all other inputs and can be used to initiate a new timing cycle. When RESET goes low, the flip-flop is reset and the output goes low. When the output is low, a low-impedance path is provided between the discharge (DISCH) terminal and ground (GND).

NA556...D OR N PACKAGE
NE556...D, N, OR NS PACKAGE
SA556...D OR N PACKAGE
SE556...J PACKAGE
(TOP VIEW)

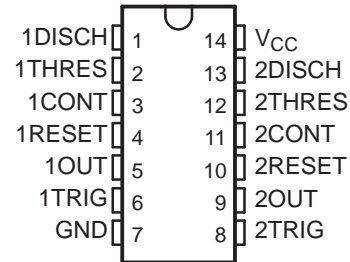

Please be aware that an important notice concerning availability, standard warranty, and use in critical applications of Texas Instruments semiconductor products and disclaimers thereto appears at the end of this data sheet.

ORDERING INFORMATION

T_A	V_T (MAX) $V_{CC} = 15\text{ V}$	PACKAGE ⁽¹⁾		ORDERABLE PART NUMBER	TOP-SIDE MARKING
0°C to 70°C	11.2 V	PDIP – N	Tube of 25	NE556N	NE556N
		SOIC – D	Tube of 50	NE556D	NE556
			Reel of 2500	NE556DR	
		SOP – NS	Reel of 2000	NE556NSR	NE556
–40°C to 85°C	11.2 V	PDIP – N	Tube of 25	SA556N	SA556N
–40°C to 105°C	11.2 V	PDIP – N	Tube of 25	NA556N	NA556N
		SOIC – D	Tube of 50	NA556D	NA556
			Reel of 2500	NA556DR	
–55°C to 125°C	10.6 V	CDIP – J	Tube of 25	SE556J	SE556J
				SE556JB	SE556JB

(1) Package drawings, standard packing quantities, thermal data, symbolization, and PCB design guidelines are available at www.ti.com/sc/package.

**FUNCTION TABLE
(each timer)**

RESET	TRIGGER VOLTAGE ⁽¹⁾	THRESHOLD VOLTAGE ⁽¹⁾	OUTPUT	DISCHARGE SWITCH
Low	Irrelevant	Irrelevant	Low	On
High	<1/3 V_{DD}	Irrelevant	High	Off
High	>1/3 V_{DD}	>2/3 V_{DD}	Low	On
High	>1/3 V_{DD}	<2/3 V_{DD}	As previously established	

(1) Voltage levels shown are nominal.

FUNCTIONAL BLOCK DIAGRAM, EACH TIMER

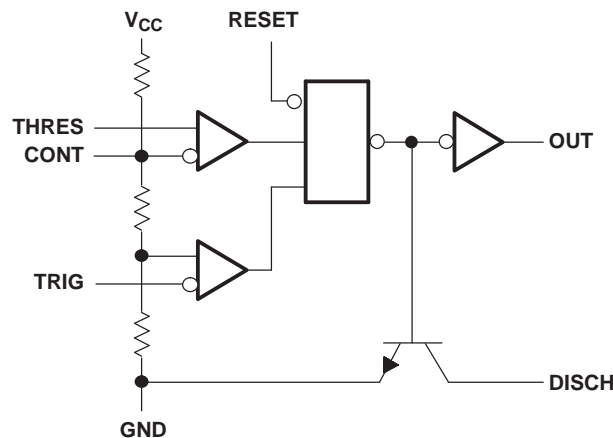

RESET can override TRIG, which can override THRES.

Absolute Maximum Ratings⁽¹⁾

over operating free-air temperature range (unless otherwise noted)

		MIN	MAX	UNIT
V _{CC}	Supply voltage ⁽²⁾		18	V
V _I	Input voltage	CONT, RESET, THRES, and TRIG		V _{CC}
I _O	Output current		±225	mA
θ _{JA}	Package thermal impedance ⁽³⁾⁽⁴⁾	D package		86
		N package		80
		NS package		76
θ _{JC}	Package thermal impedance ⁽⁵⁾⁽⁶⁾	J package		15.05
T _J	Operating virtual junction temperature		150	°C
	Lead temperature 1,6 mm (1/16 in) from case for 60 s	J package		300
	Lead temperature 1,6 mm (1/16 in) from case for 10 s	D, N, or NS package		260
T _{stg}	Storage temperature range	–65	150	°C

- (1) Stresses beyond those listed under "absolute maximum ratings" may cause permanent damage to the device. These are stress ratings only, and functional operation of the device at these or any other conditions beyond those indicated under "recommended operating conditions" is not implied. Exposure to absolute-maximum-rated conditions for extended periods may affect device reliability.
- (2) All voltage values are with respect to network ground terminal.
- (3) Maximum power dissipation is a function of T_{J(max)}, θ_{JA}, and T_A. The maximum allowable power dissipation at any allowable ambient temperature is P_D = (T_{J(max)} – T_A)/θ_{JA}. Operating at the absolute maximum T_J of 150°C can affect reliability.
- (4) The package thermal impedance is calculated in accordance with JESD 51-7.
- (5) Maximum power dissipation is a function of T_{J(max)}, θ_{JC}, and T_C. The maximum allowable power dissipation at any allowable case temperature is P_D = (T_{J(max)} – T_C)/θ_{JC}. Operating at the absolute maximum T_J of 150°C can affect reliability.
- (6) The package thermal impedance is calculated in accordance with MIL-STD-883.

Recommended Operating Conditions

		MIN	MAX	UNIT
V _{CC}	Supply voltage	NA556, NE556, SA556		V
		SE556		
V _I	Input voltage	CONT, RESET, THRES, and TRIG		V _{CC}
I _O	Output current		±200	mA
T _A	Operating free-air temperature	NA556		°C
		NE556		
		SA556		
		SE556		

Electrical Characteristics

$V_{CC} = 5\text{ V to }15\text{ V}$, $T_A = 25^\circ\text{C}$ (unless otherwise noted)

PARAMETER	TEST CONDITIONS	NA556 NE556 SA556			SE556			UNIT	
		MIN	TYP	MAX	MIN	TYP	MAX		
V_T Threshold voltage level	$V_{CC} = 15\text{ V}$	8.8	10	11.2	9.4	10	10.6	V	
	$V_{CC} = 5\text{ V}$	2.4	3.3	4.2	2.7	3.3	4		
I_T Threshold current ⁽¹⁾			30	250		30	250	nA	
V_{TRIG} Trigger voltage level	$V_{CC} = 15\text{ V}$	$T_A = -55^\circ\text{C to }125^\circ\text{C}$	4.5	5	5.6	4.8	5	5.2	V
						3		6	
	$V_{CC} = 5\text{ V}$	$T_A = -55^\circ\text{C to }125^\circ\text{C}$	1.1	1.67	2.2	1.45	1.67	1.9	
								1.9	
I_{TRIG} Trigger current	TRIG at 0 V		0.5	2		0.5	0.9	μA	
V_{RESET} Reset voltage level		0.3	0.7	1	0.3	0.7	1	V	
	$T_A = -55^\circ\text{C to }125^\circ\text{C}$						1.1		
I_{RESET} Reset current	RESET at V_{CC}		0.1	0.4		0.1	0.4	mA	
	RESET at 0 V		-0.4	1.5		-0.4	-1		
I_{DISCH} Discharge switch off-state current			20	100		20	100	nA	
V_{CONT} Control voltage (open circuit)	$V_{CC} = 15\text{ V}$	$T_A = -55^\circ\text{C to }125^\circ\text{C}$	9	10	11	9.6	10	10.4	V
						9.6		10.4	
	$V_{CC} = 5\text{ V}$	$T_A = -55^\circ\text{C to }125^\circ\text{C}$	2.6	3.3	4	2.9	3.3	3.8	
						2.9		3.8	
V_{OL} Low-level output voltage	$V_{CC} = 15\text{ V}$, $I_{OL} = 10\text{ mA}$	$T_A = -55^\circ\text{C to }125^\circ\text{C}$		0.1	0.25		0.1	0.15	V
								0.2	
	$V_{CC} = 15\text{ V}$, $I_{OL} = 50\text{ mA}$	$T_A = -55^\circ\text{C to }125^\circ\text{C}$		0.4	0.75		0.4	0.5	
								1	
	$V_{CC} = 15\text{ V}$, $I_{OL} = 100\text{ mA}$	$T_A = -55^\circ\text{C to }125^\circ\text{C}$		2	2.5		2	2.2	
								2.7	
	$V_{CC} = 15\text{ V}$, $I_{OL} = 200\text{ mA}$		2.5			2.5			
	$V_{CC} = 5\text{ V}$, $I_{OL} = 3.5\text{ mA}$	$T_A = -55^\circ\text{C to }125^\circ\text{C}$						0.35	
$V_{CC} = 5\text{ V}$, $I_{OL} = 5\text{ mA}$	$T_A = -55^\circ\text{C to }125^\circ\text{C}$		0.1	0.25		0.1	0.15		
							0.8		
$V_{CC} = 5\text{ V}$, $I_{OL} = 8\text{ mA}$			0.15	0.3		0.15	0.25		
V_{OH} High-level output voltage	$V_{CC} = 15\text{ V}$, $I_{OH} = -100\text{ mA}$	$T_A = -55^\circ\text{C to }125^\circ\text{C}$	12.75	13.3		13	13.3	V	
						12			
	$V_{CC} = 15\text{ V}$, $I_{OH} = -200\text{ mA}$		12.5			12.5			
	$V_{CC} = 5\text{ V}$, $I_{OH} = -100\text{ mA}$	$T_A = -55^\circ\text{C to }125^\circ\text{C}$	2.75	3.3		3	3.3		
					2				
I_{CC} Supply current	Output low, No load	$V_{CC} = 15\text{ V}$		20	30		20	24	mA
		$V_{CC} = 5\text{ V}$		6	12		6	10	
	Output high, No load	$V_{CC} = 15\text{ V}$		18	26		18	20	
		$V_{CC} = 5\text{ V}$		4	10		4	8	

(1) This parameter influences the maximum value of the timing resistors R and R_B in the circuit of Figure 1. For example, when $V_{CC} = 5\text{ V}$, the maximum value is $R = R_A + R_B \approx 3.4\text{ M}\Omega$, and for $V_{CC} = 15\text{ V}$, the maximum value is $\approx 10\text{ M}\Omega$.

Operating Characteristics

$V_{CC} = 5\text{ V}$ and 15 V

PARAMETER		TEST CONDITIONS ⁽¹⁾	NA556 NE556 SA556			SE556			UNIT
			MIN	TYP	MAX	MIN	TYP	MAX	
Initial error of timing interval ⁽²⁾	Each timer, monostable ⁽³⁾	$T_A = 25^\circ\text{C}$		1	3		0.5	1.5 ⁽⁴⁾	
	Each timer, astable ⁽⁵⁾			2.25%			1.5%		
	Timer 1 – Timer 2			± 1			± 0.5		
Temperature coefficient of timing interval	Each timer, monostable ⁽³⁾	$T_A = \text{MIN to MAX}$		50			30	100 ⁽⁴⁾	ppm/ $^\circ\text{C}$
	Each timer, astable ⁽⁵⁾			150			90		
	Timer 1 – Timer 2			± 10			± 10		
Supply voltage sensitivity of timing interval	Each timer, monostable ⁽³⁾	$T_A = 25^\circ\text{C}$		0.1	0.5		0.05	0.2 ⁽⁴⁾	%/ V
	Each timer, astable ⁽⁵⁾			0.3			0.15		
	Timer 1 – Timer 2			± 0.2			± 0.1		
Output-pulse rise time		$C_L = 15\text{ pF}$, $T_A = 25^\circ\text{C}$		100	300		100	200 ⁽⁴⁾	ns
Output-pulse fall time		$C_L = 15\text{ pF}$, $T_A = 25^\circ\text{C}$		100	300		100	200 ⁽⁴⁾	ns

- (1) For conditions shown as MIN or MAX, use the appropriate value specified under recommended operating conditions.
- (2) Timing-interval error is defined as the difference between the measured value and the average value of a random sample from each process run.
- (3) Values specified are for a device in a monostable circuit similar to [Figure 2](#), with the following component values: $R_A = 2\text{ k}\Omega$ to $100\text{ k}\Omega$, $C = 0.1\text{ }\mu\text{F}$.
- (4) On products compliant to MIL-PRF-38535, this parameter is not production tested.
- (5) Values specified are for a device in an astable circuit similar to [Figure 1](#), with the following component values: $R_A = 1\text{ k}\Omega$ to $100\text{ k}\Omega$, $C = 0.1\text{ }\mu\text{F}$.

APPLICATION INFORMATION

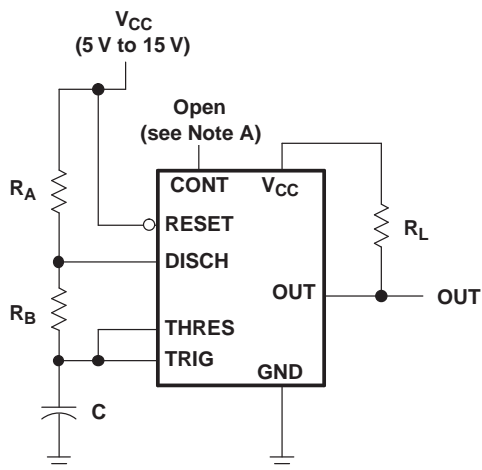

NOTE A: Bypassing the control-voltage input to ground with a capacitor might improve operation. This should be evaluated for individual applications.

Figure 1. Circuit for Astable Operation

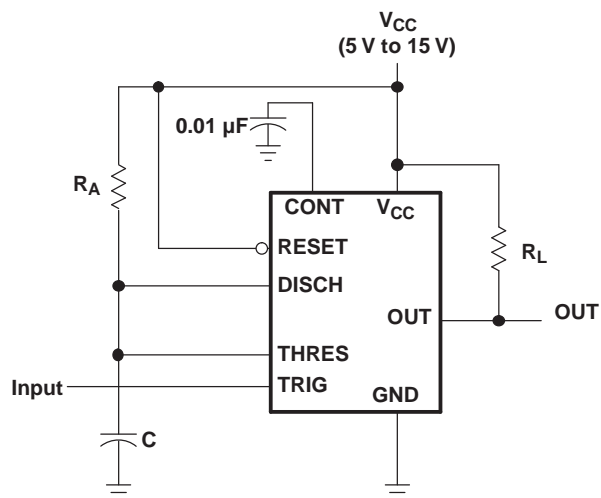

Figure 2. Circuit for Monostable Operation

PACKAGING INFORMATION

Orderable Device	Status (1)	Package Type	Package Drawing	Pins	Package Qty	Eco Plan (2)	Lead/Ball Finish (6)	MSL Peak Temp (3)	Op Temp (°C)	Device Marking (4/5)	Samples
JM38510/10902BCA	ACTIVE	CDIP	J	14	1	TBD	A42	N / A for Pkg Type	-55 to 125	JM38510 /10902BCA	Samples
M38510/10902BCA	ACTIVE	CDIP	J	14	1	TBD	A42	N / A for Pkg Type	-55 to 125	JM38510 /10902BCA	Samples
NA556D	ACTIVE	SOIC	D	14	50	Green (RoHS & no Sb/Br)	CU NIPDAU	Level-1-260C-UNLIM	-40 to 105	NA556	Samples
NA556DR	ACTIVE	SOIC	D	14	2500	Green (RoHS & no Sb/Br)	CU NIPDAU	Level-1-260C-UNLIM	-40 to 105	NA556	Samples
NA556N	ACTIVE	PDIP	N	14	25	Green (RoHS & no Sb/Br)	CU NIPDAU	N / A for Pkg Type	-40 to 105	NA556N	Samples
NE556D	ACTIVE	SOIC	D	14	50	Green (RoHS & no Sb/Br)	CU NIPDAU	Level-1-260C-UNLIM	0 to 70	NE556	Samples
NE556DBR	ACTIVE	SSOP	DB	14	2000	Green (RoHS & no Sb/Br)	CU NIPDAU	Level-1-260C-UNLIM	0 to 70	N556	Samples
NE556DR	ACTIVE	SOIC	D	14	2500	Green (RoHS & no Sb/Br)	CU NIPDAU	Level-1-260C-UNLIM	0 to 70	NE556	Samples
NE556DRE4	ACTIVE	SOIC	D	14	2500	Green (RoHS & no Sb/Br)	CU NIPDAU	Level-1-260C-UNLIM	0 to 70	NE556	Samples
NE556DRG4	ACTIVE	SOIC	D	14	2500	Green (RoHS & no Sb/Br)	CU NIPDAU	Level-1-260C-UNLIM	0 to 70	NE556	Samples
NE556N	ACTIVE	PDIP	N	14	25	Green (RoHS & no Sb/Br)	CU NIPDAU	N / A for Pkg Type	0 to 70	NE556N	Samples
NE556NE4	ACTIVE	PDIP	N	14	25	Green (RoHS & no Sb/Br)	CU NIPDAU	N / A for Pkg Type	0 to 70	NE556N	Samples
NE556NSR	ACTIVE	SO	NS	14	2000	Green (RoHS & no Sb/Br)	CU NIPDAU	Level-1-260C-UNLIM	0 to 70	NE556	Samples
SA556N	ACTIVE	PDIP	N	14	25	Green (RoHS & no Sb/Br)	CU NIPDAU	N / A for Pkg Type	-40 to 85	SA556N	Samples
SA556NE4	ACTIVE	PDIP	N	14	25	Green (RoHS & no Sb/Br)	CU NIPDAU	N / A for Pkg Type	-40 to 85	SA556N	Samples
SE556J	ACTIVE	CDIP	J	14	1	TBD	A42	N / A for Pkg Type	-55 to 125	SE556J	Samples
SE556JB	ACTIVE	CDIP	J	14	1	TBD	A42	N / A for Pkg Type	-55 to 125	SE556JB	Samples

(1) The marketing status values are defined as follows:

ACTIVE: Product device recommended for new designs.

LIFEBUY: TI has announced that the device will be discontinued, and a lifetime-buy period is in effect.

NRND: Not recommended for new designs. Device is in production to support existing customers, but TI does not recommend using this part in a new design.

PREVIEW: Device has been announced but is not in production. Samples may or may not be available.

OBSOLETE: TI has discontinued the production of the device.

(2) **RoHS:** TI defines "RoHS" to mean semiconductor products that are compliant with the current EU RoHS requirements for all 10 RoHS substances, including the requirement that RoHS substance do not exceed 0.1% by weight in homogeneous materials. Where designed to be soldered at high temperatures, "RoHS" products are suitable for use in specified lead-free processes. TI may reference these types of products as "Pb-Free".

RoHS Exempt: TI defines "RoHS Exempt" to mean products that contain lead but are compliant with EU RoHS pursuant to a specific EU RoHS exemption.

Green: TI defines "Green" to mean the content of Chlorine (Cl) and Bromine (Br) based flame retardants meet JS709B low halogen requirements of ≤ 1000 ppm threshold. Antimony trioxide based flame retardants must also meet the ≤ 1000 ppm threshold requirement.

(3) MSL, Peak Temp. - The Moisture Sensitivity Level rating according to the JEDEC industry standard classifications, and peak solder temperature.

(4) There may be additional marking, which relates to the logo, the lot trace code information, or the environmental category on the device.

(5) Multiple Device Markings will be inside parentheses. Only one Device Marking contained in parentheses and separated by a "~" will appear on a device. If a line is indented then it is a continuation of the previous line and the two combined represent the entire Device Marking for that device.

(6) Lead/Ball Finish - Orderable Devices may have multiple material finish options. Finish options are separated by a vertical ruled line. Lead/Ball Finish values may wrap to two lines if the finish value exceeds the maximum column width.

Important Information and Disclaimer: The information provided on this page represents TI's knowledge and belief as of the date that it is provided. TI bases its knowledge and belief on information provided by third parties, and makes no representation or warranty as to the accuracy of such information. Efforts are underway to better integrate information from third parties. TI has taken and continues to take reasonable steps to provide representative and accurate information but may not have conducted destructive testing or chemical analysis on incoming materials and chemicals. TI and TI suppliers consider certain information to be proprietary, and thus CAS numbers and other limited information may not be available for release.

In no event shall TI's liability arising out of such information exceed the total purchase price of the TI part(s) at issue in this document sold by TI to Customer on an annual basis.

TAPE AND REEL INFORMATION

QUADRANT ASSIGNMENTS FOR PIN 1 ORIENTATION IN TAPE

*All dimensions are nominal

Device	Package Type	Package Drawing	Pins	SPQ	Reel Diameter (mm)	Reel Width W1 (mm)	A0 (mm)	B0 (mm)	K0 (mm)	P1 (mm)	W (mm)	Pin1 Quadrant
NA556DR	SOIC	D	14	2500	330.0	16.4	6.5	9.0	2.1	8.0	16.0	Q1
NE556DR	SOIC	D	14	2500	330.0	16.4	6.5	9.0	2.1	8.0	16.0	Q1
NE556NSR	SO	NS	14	2000	330.0	16.4	8.2	10.5	2.5	12.0	16.0	Q1

TAPE AND REEL BOX DIMENSIONS

*All dimensions are nominal

Device	Package Type	Package Drawing	Pins	SPQ	Length (mm)	Width (mm)	Height (mm)
NA556DR	SOIC	D	14	2500	367.0	367.0	38.0
NE556DR	SOIC	D	14	2500	367.0	367.0	38.0
NE556NSR	SO	NS	14	2000	367.0	367.0	38.0

MECHANICAL DATA

NS (R-PDSO-G**)

PLASTIC SMALL-OUTLINE PACKAGE

14-PINS SHOWN



- NOTES:
- A. All linear dimensions are in millimeters.
 - B. This drawing is subject to change without notice.
 - C. Body dimensions do not include mold flash or protrusion, not to exceed 0,15.

J 14

GENERIC PACKAGE VIEW
CDIP - 5.08 mm max height
CERAMIC DUAL IN LINE PACKAGE



Images above are just a representation of the package family, actual package may vary.
Refer to the product data sheet for package details.

4040083-5/G

J0014A



PACKAGE OUTLINE

CDIP - 5.08 mm max height

CERAMIC DUAL IN LINE PACKAGE



4214771/A 05/2017

NOTES:

1. All controlling linear dimensions are in inches. Dimensions in brackets are in millimeters. Any dimension in brackets or parenthesis are for reference only. Dimensioning and tolerancing per ASME Y14.5M.
2. This drawing is subject to change without notice.
3. This package is hermetically sealed with a ceramic lid using glass frit.
4. Index point is provided on cap for terminal identification only and on press ceramic glass frit seal only.
5. Falls within MIL-STD-1835 and GDIP1-T14.

EXAMPLE BOARD LAYOUT

J0014A

CDIP - 5.08 mm max height

CERAMIC DUAL IN LINE PACKAGE



LAND PATTERN EXAMPLE
NON-SOLDER MASK DEFINED
SCALE: 5X

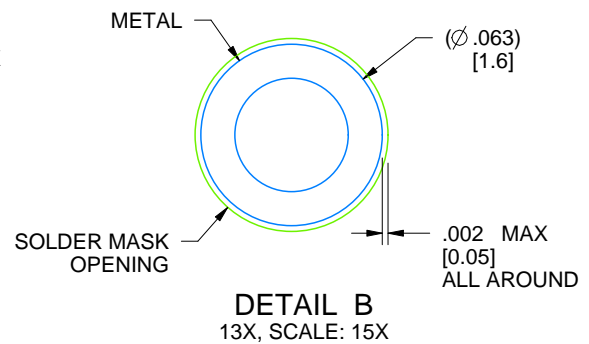

4214771/A 05/2017

D (R-PDSO-G14)

PLASTIC SMALL OUTLINE



- NOTES:
- All linear dimensions are in millimeters.
 - This drawing is subject to change without notice.
 - Publication IPC-7351 is recommended for alternate designs.
 - Laser cutting apertures with trapezoidal walls and also rounding corners will offer better paste release. Customers should contact their board assembly site for stencil design recommendations. Refer to IPC-7525 for other stencil recommendations.
 - Customers should contact their board fabrication site for solder mask tolerances between and around signal pads.

N (R-PDIP-T**)

PLASTIC DUAL-IN-LINE PACKAGE

16 PINS SHOWN



- NOTES:
- A. All linear dimensions are in inches (millimeters).
 - B. This drawing is subject to change without notice.
 - C. Falls within JEDEC MS-001, except 18 and 20 pin minimum body length (Dim A).
 - D. The 20 pin end lead shoulder width is a vendor option, either half or full width.

DB (R-PDSO-G**)

PLASTIC SMALL-OUTLINE

28 PINS SHOWN



- NOTES: A. All linear dimensions are in millimeters.
 B. This drawing is subject to change without notice.
 C. Body dimensions do not include mold flash or protrusion not to exceed 0,15.
 D. Falls within JEDEC MO-150

IMPORTANT NOTICE AND DISCLAIMER

TI PROVIDES TECHNICAL AND RELIABILITY DATA (INCLUDING DATASHEETS), DESIGN RESOURCES (INCLUDING REFERENCE DESIGNS), APPLICATION OR OTHER DESIGN ADVICE, WEB TOOLS, SAFETY INFORMATION, AND OTHER RESOURCES "AS IS" AND WITH ALL FAULTS, AND DISCLAIMS ALL WARRANTIES, EXPRESS AND IMPLIED, INCLUDING WITHOUT LIMITATION ANY IMPLIED WARRANTIES OF MERCHANTABILITY, FITNESS FOR A PARTICULAR PURPOSE OR NON-INFRINGEMENT OF THIRD PARTY INTELLECTUAL PROPERTY RIGHTS.

These resources are intended for skilled developers designing with TI products. You are solely responsible for (1) selecting the appropriate TI products for your application, (2) designing, validating and testing your application, and (3) ensuring your application meets applicable standards, and any other safety, security, or other requirements. These resources are subject to change without notice. TI grants you permission to use these resources only for development of an application that uses the TI products described in the resource. Other reproduction and display of these resources is prohibited. No license is granted to any other TI intellectual property right or to any third party intellectual property right. TI disclaims responsibility for, and you will fully indemnify TI and its representatives against, any claims, damages, costs, losses, and liabilities arising out of your use of these resources.

TI's products are provided subject to TI's Terms of Sale (www.ti.com/legal/termsofsale.html) or other applicable terms available either on ti.com or provided in conjunction with such TI products. TI's provision of these resources does not expand or otherwise alter TI's applicable warranties or warranty disclaimers for TI products.

Mailing Address: Texas Instruments, Post Office Box 655303, Dallas, Texas 75265
Copyright © 2019, Texas Instruments Incorporated

Looking for pricing, stock, or lifecycle information?

Click below to explore more details on WIN SOURCE:

 [View NE556N-E4 on WIN SOURCE](#)

 [Texas Instruments](#) Information

Optimize Your Supply Chain with WIN SOURCE Solutions

-  Global Sourcing Solution
-  Obsolete Management
-  Cost Control Management
-  Shortage Management
-  Alternative Solution
-  Excess Inventory Management