



**THE DATASHEET OF  
NCV33064D-5R2**



# MC34064, MC33064, NCV33064

## Undervoltage Sensing Circuit

The MC34064 is an undervoltage sensing circuit specifically designed for use as a reset controller in microprocessor-based systems. It offers the designer an economical solution for low voltage detection with a single external resistor. The MC34064 features a trimmed-in-package bandgap reference, and a comparator with precise thresholds and built-in hysteresis to prevent erratic reset operation. The open collector reset output is capable of sinking in excess of 10 mA, and operation is guaranteed down to 1.0 V input with low standby current. The MC devices are packaged in 3-pin TO-92, micro size TSOP-5, 8-pin SOIC-8 and Micro8™ surface mount packages. The NCV device is packaged in SOIC-8 and TO-92.

Applications include direct monitoring of the 5.0 V MPU/logic power supply used in appliance, automotive, consumer and industrial equipment.

### Features

- Trimmed-In-Package Temperature Compensated Reference
- Comparator Threshold of 4.6 V at 25°C
- Precise Comparator Thresholds Guaranteed Over Temperature
- Comparator Hysteresis Prevents Erratic Reset
- Reset Output Capable of Sinking in Excess of 10 mA
- Internal Clamp Diode for Discharging Delay Capacitor
- Guaranteed Reset Operation with 1.0 V Input
- Low Standby Current
- Economical TO-92, TSOP-5, SOIC-8 and Micro8 Surface Mount Packages
- NCV Prefix for Automotive and Other Applications Requiring Site and Control Changes
- These Devices are Pb-Free and are RoHS Compliant

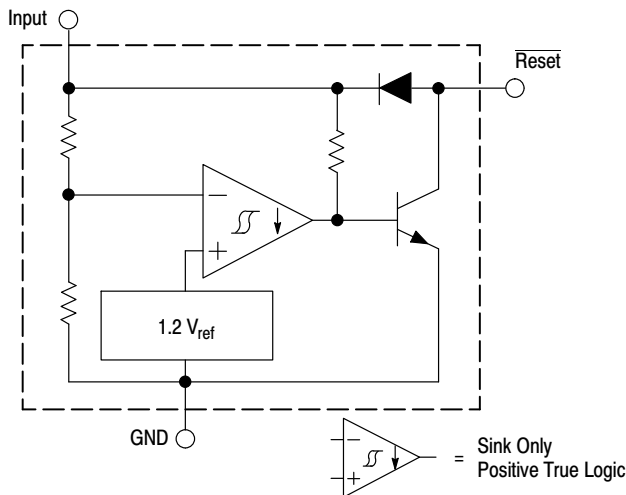

This device contains 21 active transistors.

**Figure 1. Representative Block Diagram**



**ON Semiconductor®**

[www.onsemi.com](http://www.onsemi.com)



**SOIC-8  
D SUFFIX  
CASE 751**

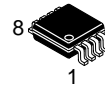

**Micro8  
DM SUFFIX  
CASE 846A**



**TSOP-5  
SN SUFFIX  
CASE 483**

Pin 1. Ground  
2. Input  
3. Reset  
4. NC  
5. NC

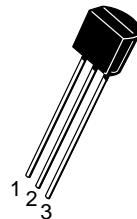

**STRAIGHT LEAD  
BULK PACK**

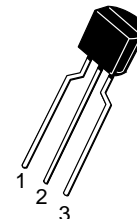

**BENT LEAD  
TAPE & REEL  
AMMO PACK**

**TO-92  
P SUFFIX  
CASE 29**

Pin 1.  $\overline{\text{Reset}}$   
2. Input  
3. Ground

### PIN CONNECTIONS

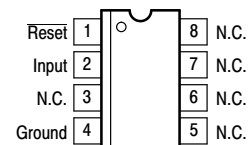

(Top View)

### ORDERING INFORMATION

See detailed ordering and shipping information in the package dimensions section on page 6 of this data sheet.

### DEVICE MARKING INFORMATION

See general marking information in the device marking section on page 7 of this data sheet.



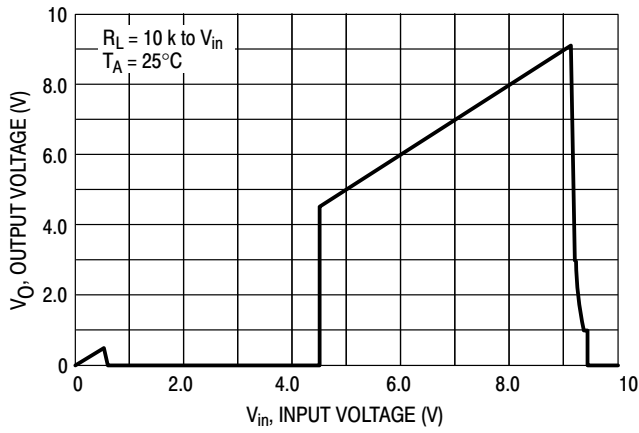

Figure 2. Reset Output Voltage versus Input Voltage

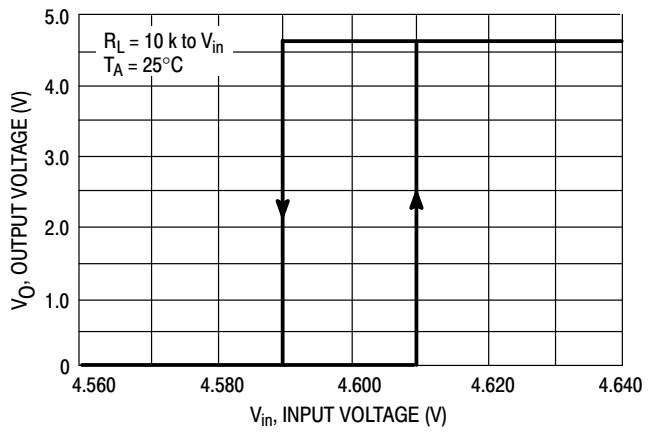

Figure 3. Reset Output Voltage versus Input Voltage



Figure 4. Comparator Threshold Voltage versus Temperature



Figure 5. Input Current versus Input Voltage

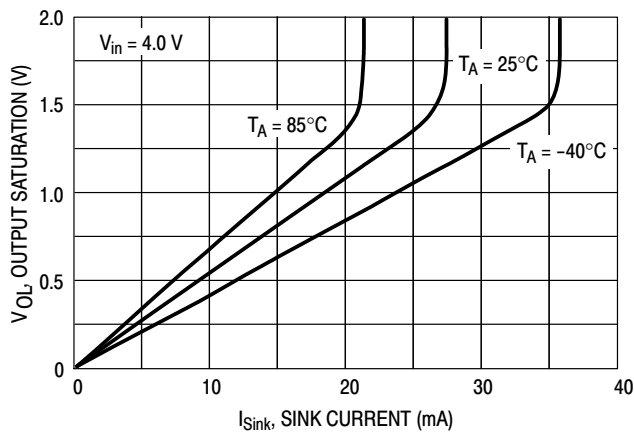

Figure 6. Reset Output Saturation versus Sink Current

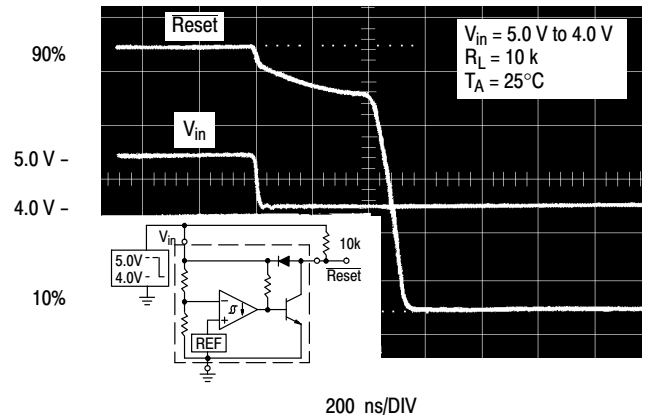

Figure 7. Reset Delay Time

# MC34064, MC33064, NCV33064

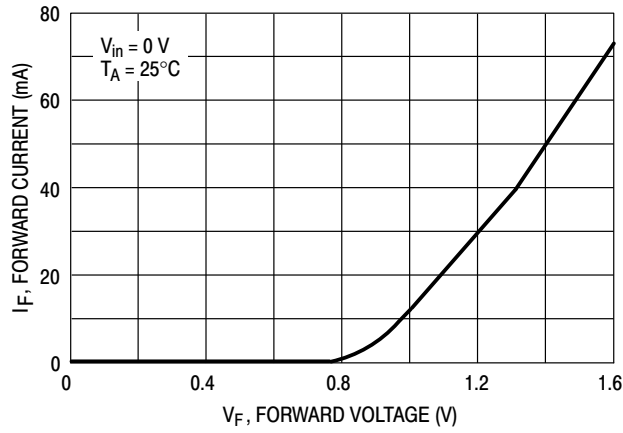

Figure 8. Clamp Diode Forward Current versus Voltage

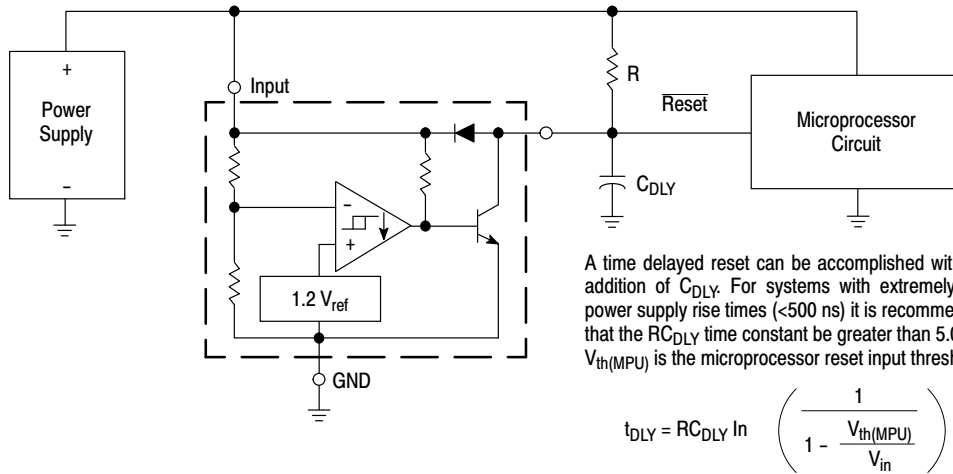
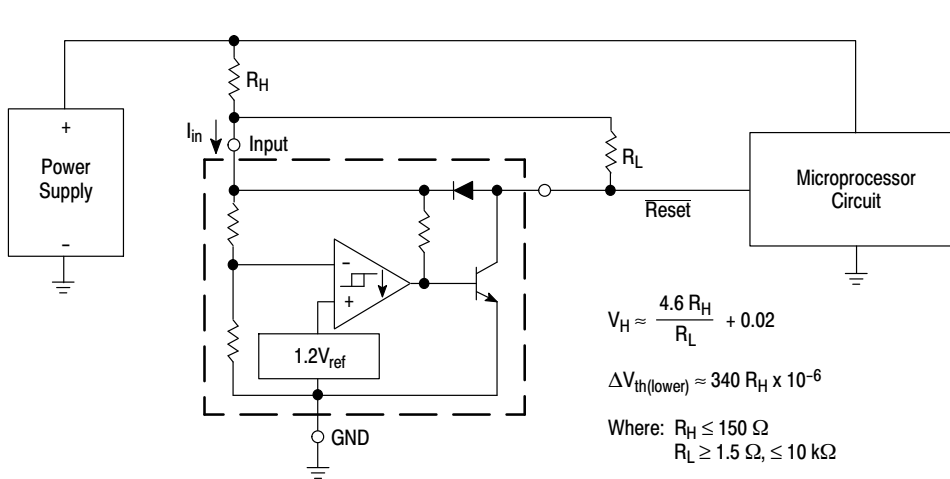

Figure 9. Low Voltage Microprocessor Reset



## TEST DATA

| $V_H$ (mV) | $\Delta V_{th}$ (mV) | $R_H$ ( $\Omega$ ) | $R_L$ (k $\Omega$ ) |
|------------|----------------------|--------------------|---------------------|
| 20         | 0                    | 0                  | 0                   |
| 51         | 3.4                  | 10                 | 1.5                 |
| 40         | 6.8                  | 20                 | 4.7                 |
| 81         | 6.8                  | 20                 | 1.5                 |
| 71         | 10                   | 30                 | 2.7                 |
| 112        | 10                   | 30                 | 1.5                 |
| 100        | 16                   | 47                 | 2.7                 |
| 164        | 16                   | 47                 | 1.5                 |
| 190        | 34                   | 100                | 2.7                 |
| 327        | 34                   | 100                | 1.5                 |
| 276        | 51                   | 150                | 2.7                 |
| 480        | 51                   | 150                | 1.5                 |

Figure 10. Low Voltage Microprocessor Reset with Additional Hysteresis

# MC34064, MC33064, NCV33064

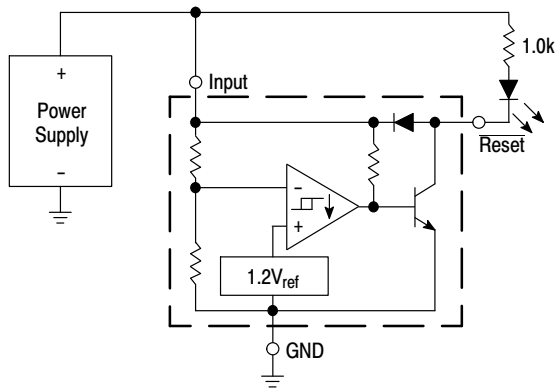

Figure 11. Voltage Monitor

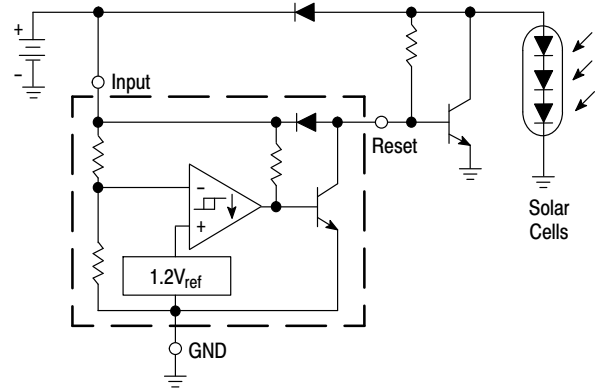
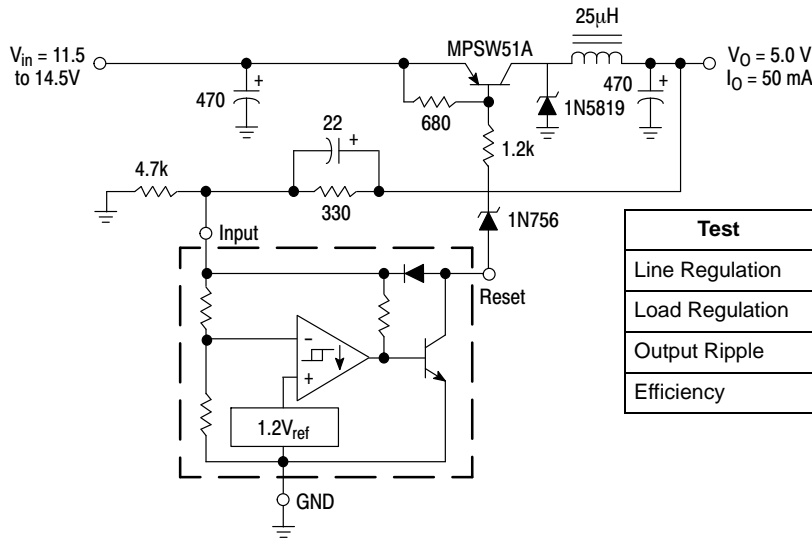
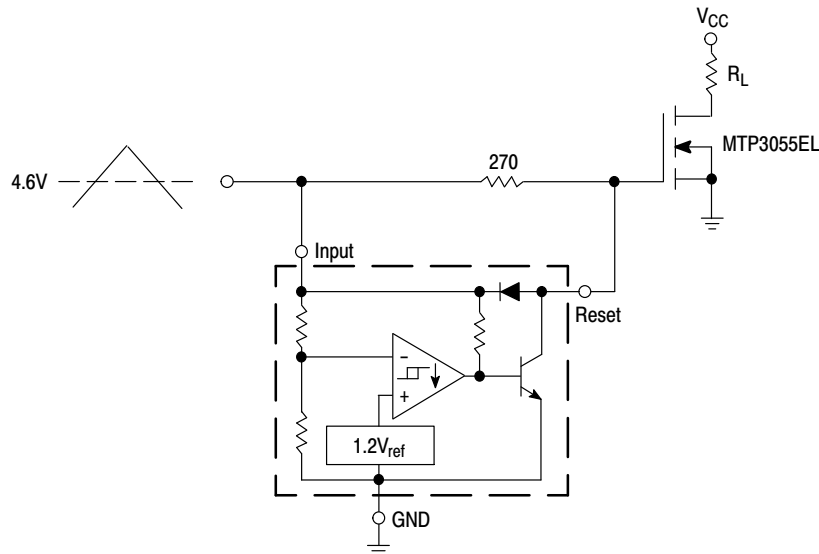

Figure 12. Solar Powered Battery Charger



| Test            | Conditions  | Results |
|-----------------|---|---------|
| Line Regulation | $V_{in} = 11.5\text{ V to }14.5\text{ V}, I_O = 50\text{ mA}$ | 35 mV   |
| Load Regulation | $V_{in} = 12.6\text{ V}, I_O = 0\text{ mA to }50\text{ mA}$   | 12 mV   |
| Output Ripple   | $V_{in} = 12.6\text{ V}, I_O = 50\text{ mA}$                  | 60 mVpp |
| Efficiency      | $V_{in} = 12.6\text{ V}, I_O = 50\text{ mA}$                  | 77%     |

Figure 13. Low Power Switching Regulator



Overheating of the logic level power MOSFET due to insufficient gate voltage can be prevented with the above circuit. When the input signal is below the 4.6 V threshold of the MC34064, its output grounds the gate of the L<sup>2</sup> MOSFET.

Figure 14. MOSFET Low Voltage Gate Drive Protection

# MC34064, MC33064, NCV33064

## ORDERING INFORMATION

| Device           | Operating Temperature Range                      | Package             | Shipping <sup>†</sup>    |
|------------------|--|---------------------|--------------------------|
| MC34064D-5G      | $T_A = 0^\circ\text{C to } +70^\circ\text{C}$    | SOIC-8<br>(Pb-Free) | 98 Units / Rail          |
| MC34064D-5R2G    |  | SOIC-8<br>(Pb-Free) | 2500 Units/ Tape & Reel  |
| MC34064DM-5R2G   |  | Micro8<br>(Pb-Free) | 4000 Units / Tape & Reel |
| MC34064P-5G      |  | TO-92<br>(Pb-Free)  | 2000 Units / Bag         |
| MC34064P-5RAG    |  | TO-92<br>(Pb-Free)  | 2000 Units / Tape & Reel |
| MC34064P-5RPG    |  | TO-92<br>(Pb-Free)  | 2000 Units / Ammo Pack   |
| MC34064P-5RMG    |  | TO-92<br>(Pb-Free)  |                          |
| MC34064SN-5T1G   |  | TSOP-5<br>(Pb-Free) | 3000 Units / Tape & Reel |
| MC33064D-5G      | $T_A = -40^\circ\text{C to } +85^\circ\text{C}$  | SOIC-8<br>(Pb-Free) | 98 Units / Rail          |
| MC33064D-5R2G    |  | SOIC-8<br>(Pb-Free) | 2500 Units / Tape & Reel |
| MC33064DM-5R2G   |  | Micro8<br>(Pb-Free) | 4000 Units / Tape & Reel |
| MC33064P-5G      |  | TO-92<br>(Pb-Free)  | 2000 Units / Bag         |
| MC33064P-5RAG    |  | TO-92<br>(Pb-Free)  | 2000 Units / Tape & Reel |
| MC33064P-5RPG    |  | TO-92<br>(Pb-Free)  | 2000 Units / Ammo Pack   |
| MC33064SN-5T1G   |  | TSOP-5<br>(Pb-Free) | 3000 Units / Tape & Reel |
| NCV33064D-5R2G*  | $T_A = -40^\circ\text{C to } +125^\circ\text{C}$ | SOIC-8<br>(Pb-Free) | 2500 Units / Tape & Reel |
| NCV33064P-5RAG*  |  | TO-92<br>(Pb-Free)  | 2000 Units / Tape & Reel |
| NCV33064P-5RPG*  |  | TO-92<br>(Pb-Free)  | 2000 Units / Ammo Pack   |
| NCV33064DM-5R2G* |  | Micro8<br>(Pb-Free) | 4000 Units / Tape & Reel |

<sup>†</sup>For information on tape and reel specifications, including part orientation and tape sizes, please refer to our Tape and Reel Packaging Specifications Brochure, BRD8011/D.

\*NCV33064:  $T_{low} = -40^\circ\text{C}$ ,  $T_{high} = +125^\circ\text{C}$ . Guaranteed by design. NCV prefix is for automotive and other applications requiring site and change control.

# MC34064, MC33064, NCV33064

## MARKING DIAGRAMS

**SOIC-8**  
**D SUFFIX**  
**CASE 751**

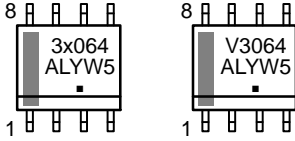

**Micro8**  
**DM SUFFIX**  
**CASE 846A**

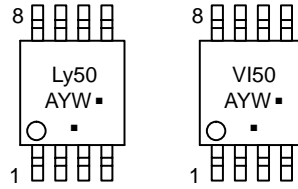

**TO-92**  
**P SUFFIX**  
**CASE 29**

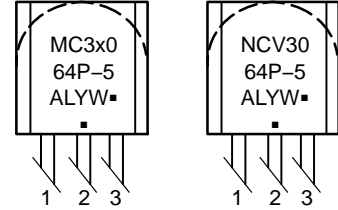

**TSOP-5**  
**SN SUFFIX**  
**CASE 483**

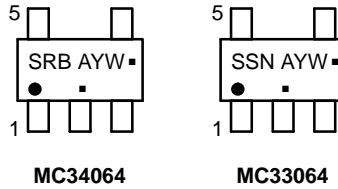

- x = 3 or 4
- y = C or I
- A = Assembly Location
- L = Wafer Lot
- Y = Year
- W = Work Week
- = Pb-Free Package

(Note: Microdot may be in either location)

# MC34064, MC33064, NCV33064

## PACKAGE DIMENSIONS

SOIC-8  
D SUFFIX  
CASE 751-07  
ISSUE AK

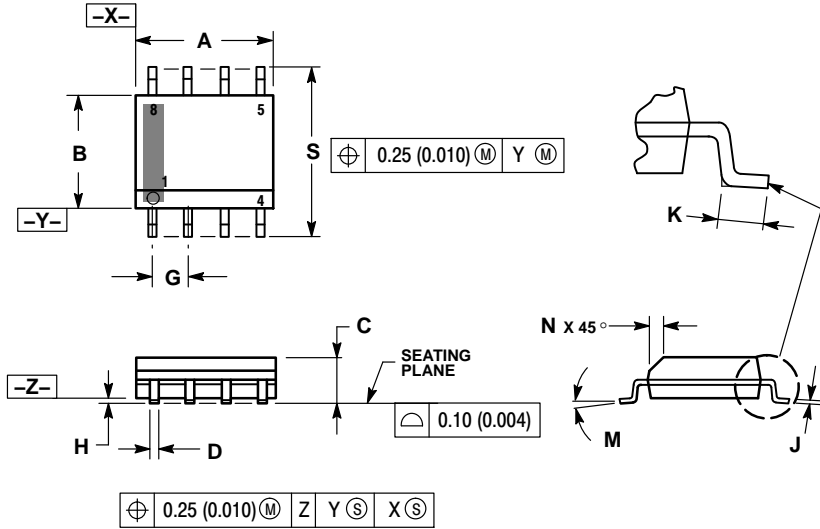

**NOTES:**

1. DIMENSIONING AND TOLERANCING PER ANSI Y14.5M, 1982.
2. CONTROLLING DIMENSION: MILLIMETER.
3. DIMENSION A AND B DO NOT INCLUDE MOLD PROTRUSION.
4. MAXIMUM MOLD PROTRUSION 0.15 (0.006) PER SIDE.
5. DIMENSION D DOES NOT INCLUDE DAMBAR PROTRUSION. ALLOWABLE DAMBAR PROTRUSION SHALL BE 0.127 (0.005) TOTAL IN EXCESS OF THE D DIMENSION AT MAXIMUM MATERIAL CONDITION.
6. 751-01 THRU 751-06 ARE OBSOLETE. NEW STANDARD IS 751-07.

| DIM | MILLIMETERS |      | INCHES    |       |
|-----|-------------|------|-----------|-------|
|     | MIN         | MAX  | MIN       | MAX   |
| A   | 4.80        | 5.00 | 0.189     | 0.197 |
| B   | 3.80        | 4.00 | 0.150     | 0.157 |
| C   | 1.35        | 1.75 | 0.053     | 0.069 |
| D   | 0.33        | 0.51 | 0.013     | 0.020 |
| G   | 1.27 BSC    |      | 0.050 BSC |       |
| H   | 0.10        | 0.25 | 0.004     | 0.010 |
| J   | 0.19        | 0.25 | 0.007     | 0.010 |
| K   | 0.40        | 1.27 | 0.016     | 0.050 |
| M   | 0°          | 8°   | 0°        | 8°    |
| N   | 0.25        | 0.50 | 0.010     | 0.020 |
| S   | 5.80        | 6.20 | 0.228     | 0.244 |

### SOLDERING FOOTPRINT\*

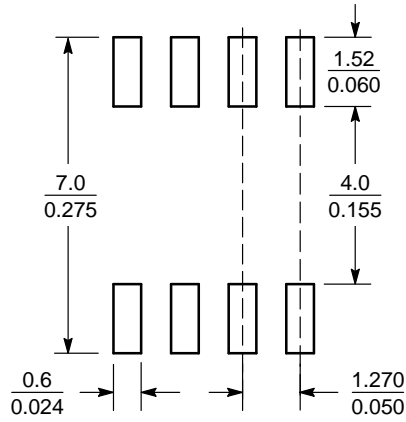

SCALE 6:1 (mm/inches)

\*For additional information on our Pb-Free strategy and soldering details, please download the ON Semiconductor Soldering and Mounting Techniques Reference Manual, SOLDERRM/D.

# MC34064, MC33064, NCV33064

## PACKAGE DIMENSIONS

### Micro8 DM SUFFIX CASE 846A-02 ISSUE J

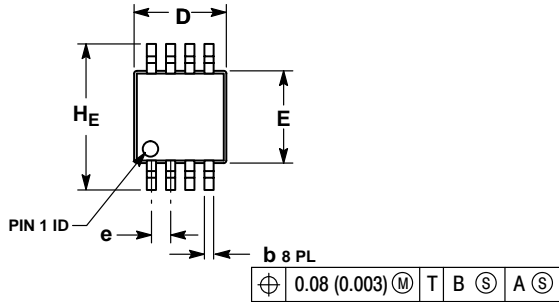

NOTES:

1. DIMENSIONING AND TOLERANCING PER ANSI Y14.5M, 1982.
2. CONTROLLING DIMENSION: MILLIMETER.
3. DIMENSION A DOES NOT INCLUDE MOLD FLASH, PROTRUSIONS OR GATE BURRS. MOLD FLASH, PROTRUSIONS OR GATE BURRS SHALL NOT EXCEED 0.15 (0.006) PER SIDE.
4. DIMENSION B DOES NOT INCLUDE INTERLEAD FLASH OR PROTRUSION. INTERLEAD FLASH OR PROTRUSION SHALL NOT EXCEED 0.25 (0.010) PER SIDE.
5. 846A-01 OBSOLETE, NEW STANDARD 846A-02.

| DIM | MILLIMETERS |      |      | INCHES    |       |       |
|-----|-------------|------|------|-----------|-------|-------|
|     | MIN         | NOM  | MAX  | MIN       | NOM   | MAX   |
| A   | —           | —    | 1.10 | —         | —     | 0.043 |
| A1  | 0.05        | 0.08 | 0.15 | 0.002     | 0.003 | 0.006 |
| b   | 0.25        | 0.33 | 0.40 | 0.010     | 0.013 | 0.016 |
| c   | 0.13        | 0.18 | 0.23 | 0.005     | 0.007 | 0.009 |
| D   | 2.90        | 3.00 | 3.10 | 0.114     | 0.118 | 0.122 |
| E   | 2.90        | 3.00 | 3.10 | 0.114     | 0.118 | 0.122 |
| e   | 0.65 BSC    |      |      | 0.026 BSC |       |       |
| L   | 0.40        | 0.55 | 0.70 | 0.016     | 0.021 | 0.028 |
| HE  | 4.75        | 4.90 | 5.05 | 0.187     | 0.193 | 0.199 |

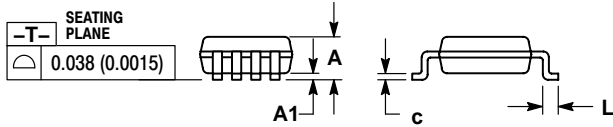

### RECOMMENDED SOLDERING FOOTPRINT\*

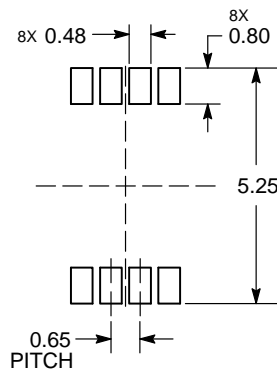

DIMENSION: MILLIMETERS

\*For additional information on our Pb-Free strategy and soldering details, please download the ON Semiconductor Soldering and Mounting Techniques Reference Manual, SOLDERRM/D.

PACKAGE DIMENSIONS

TSOP-5  
SN SUFFIX  
CASE 483  
ISSUE M

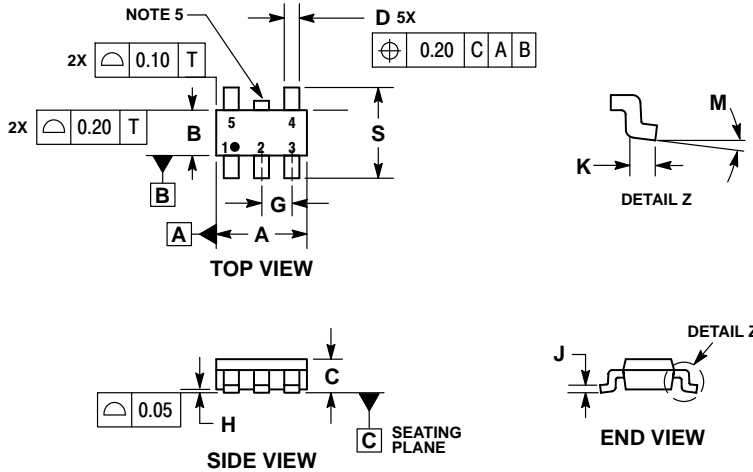

NOTES:

1. DIMENSIONING AND TOLERANCING PER ASME Y14.5M, 1994.
2. CONTROLLING DIMENSION: MILLIMETERS.
3. MAXIMUM LEAD THICKNESS INCLUDES LEAD FINISH THICKNESS. MINIMUM LEAD THICKNESS IS THE MINIMUM THICKNESS OF BASE MATERIAL.
4. DIMENSIONS A AND B DO NOT INCLUDE MOLD FLASH, PROTRUSIONS, OR GATE BURRS. MOLD FLASH, PROTRUSIONS, OR GATE BURRS SHALL NOT EXCEED 0.15 PER SIDE. DIMENSION A.
5. OPTIONAL CONSTRUCTION: AN ADDITIONAL TRIMMED LEAD IS ALLOWED IN THIS LOCATION. TRIMMED LEAD NOT TO EXTEND MORE THAN 0.2 FROM BODY.

| DIM | MILLIMETERS |      |
|-----|-------------|------|
|     | MIN         | MAX  |
| A   | 2.85        | 3.15 |
| B   | 1.35        | 1.65 |
| C   | 0.90        | 1.10 |
| D   | 0.25        | 0.50 |
| G   | 0.95 BSC    |      |
| H   | 0.01        | 0.10 |
| J   | 0.10        | 0.26 |
| K   | 0.20        | 0.60 |
| M   | 0°          | 10°  |
| S   | 2.50        | 3.00 |

SOLDERING FOOTPRINT\*

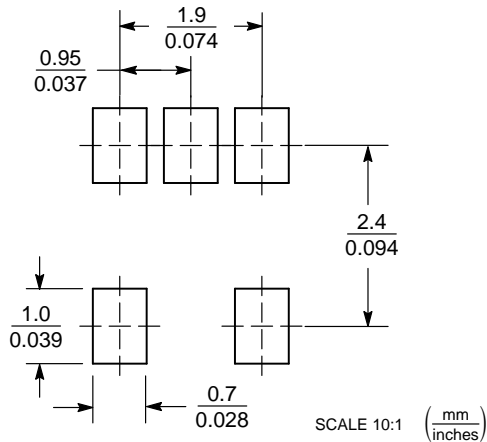

\*For additional information on our Pb-Free strategy and soldering details, please download the ON Semiconductor Soldering and Mounting Techniques Reference Manual, SOLDERRM/D.

# MC34064, MC33064, NCV33064

## PACKAGE DIMENSIONS

TO-92 (TO-226)  
P SUFFIX  
CASE 29-11  
ISSUE AM

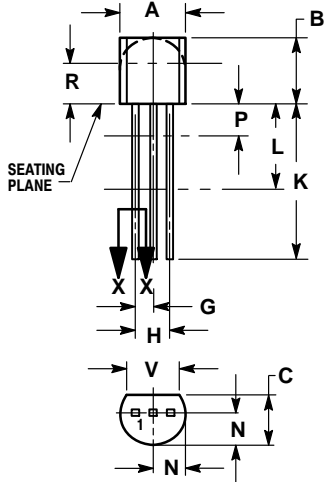

STRAIGHT LEAD  
BULK PACK

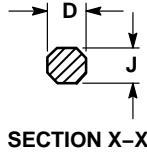

NOTES:

1. DIMENSIONING AND TOLERANCING PER ANSI Y14.5M, 1982.
2. CONTROLLING DIMENSION: INCH.
3. CONTOUR OF PACKAGE BEYOND DIMENSION R IS UNCONTROLLED.
4. LEAD DIMENSION IS UNCONTROLLED IN P AND BEYOND DIMENSION K MINIMUM.

| DIM | INCHES |       | MILLIMETERS |       |
|-----|--------|-------|-------------|-------|
|     | MIN    | MAX   | MIN         | MAX   |
| A   | 0.175  | 0.205 | 4.45        | 5.20  |
| B   | 0.170  | 0.210 | 4.32        | 5.33  |
| C   | 0.125  | 0.165 | 3.18        | 4.19  |
| D   | 0.016  | 0.021 | 0.407       | 0.533 |
| G   | 0.045  | 0.055 | 1.15        | 1.39  |
| H   | 0.095  | 0.105 | 2.42        | 2.66  |
| J   | 0.015  | 0.020 | 0.39        | 0.50  |
| K   | 0.500  | ---   | 12.70       | ---   |
| L   | 0.250  | ---   | 6.35        | ---   |
| N   | 0.080  | 0.105 | 2.04        | 2.66  |
| P   | ---    | 0.100 | ---         | 2.54  |
| R   | 0.115  | ---   | 2.93        | ---   |
| V   | 0.135  | ---   | 3.43        | ---   |

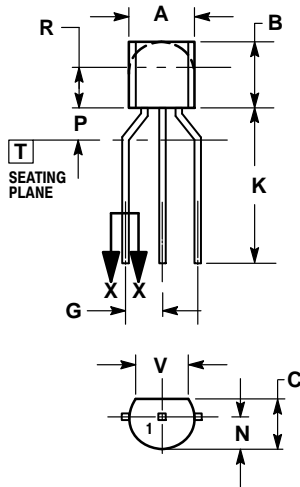

BENT LEAD  
TAPE & REEL  
AMMO PACK

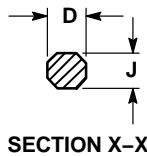

NOTES:

1. DIMENSIONING AND TOLERANCING PER ASME Y14.5M, 1994.
2. CONTROLLING DIMENSION: MILLIMETERS.
3. CONTOUR OF PACKAGE BEYOND DIMENSION R IS UNCONTROLLED.
4. LEAD DIMENSION IS UNCONTROLLED IN P AND BEYOND DIMENSION K MINIMUM.

| DIM | MILLIMETERS |      |
|-----|-------------|------|
|     | MIN         | MAX  |
| A   | 4.45        | 5.20 |
| B   | 4.32        | 5.33 |
| C   | 3.18        | 4.19 |
| D   | 0.40        | 0.54 |
| G   | 2.40        | 2.80 |
| J   | 0.39        | 0.50 |
| K   | 12.70       | ---  |
| N   | 2.04        | 2.66 |
| P   | 1.50        | 4.00 |
| R   | 2.93        | ---  |
| V   | 3.43        | ---  |

Micro8 is a trademark of International Rectifier.

ON Semiconductor and  are trademarks of Semiconductor Components Industries, LLC dba ON Semiconductor or its subsidiaries in the United States and/or other countries. ON Semiconductor owns the rights to a number of patents, trademarks, copyrights, trade secrets, and other intellectual property. A listing of ON Semiconductor's product/patent coverage may be accessed at [www.onsemi.com/site/pdf/Patent-Marking.pdf](http://www.onsemi.com/site/pdf/Patent-Marking.pdf). ON Semiconductor reserves the right to make changes without further notice to any products herein. ON Semiconductor makes no warranty, representation or guarantee regarding the suitability of its products for any particular purpose, nor does ON Semiconductor assume any liability arising out of the application or use of any product or circuit, and specifically disclaims any and all liability, including without limitation special, consequential or incidental damages. Buyer is responsible for its products and applications using ON Semiconductor products, including compliance with all laws, regulations and safety requirements or standards, regardless of any support or applications information provided by ON Semiconductor. "Typical" parameters which may be provided in ON Semiconductor data sheets and/or specifications can and do vary in different applications and actual performance may vary over time. All operating parameters, including "Typicals" must be validated for each customer application by customer's technical experts. ON Semiconductor does not convey any license under its patent rights nor the rights of others. ON Semiconductor products are not designed, intended, or authorized for use as a critical component in life support systems or any FDA Class 3 medical devices or medical devices with a same or similar classification in a foreign jurisdiction or any devices intended for implantation in the human body. Should Buyer purchase or use ON Semiconductor products for any such unintended or unauthorized application, Buyer shall indemnify and hold ON Semiconductor and its officers, employees, subsidiaries, affiliates, and distributors harmless against all claims, costs, damages, and expenses, and reasonable attorney fees arising out of, directly or indirectly, any claim of personal injury or death associated with such unintended or unauthorized use, even if such claim alleges that ON Semiconductor was negligent regarding the design or manufacture of the part. ON Semiconductor is an Equal Opportunity/Affirmative Action Employer. This literature is subject to all applicable copyright laws and is not for resale in any manner.

### PUBLICATION ORDERING INFORMATION

**LITERATURE FULFILLMENT:**

Literature Distribution Center for ON Semiconductor  
19521 E. 32nd Pkwy, Aurora, Colorado 80011 USA  
Phone: 303-675-2175 or 800-344-3860 Toll Free USA/Canada  
Fax: 303-675-2176 or 800-344-3867 Toll Free USA/Canada  
Email: [orderlit@onsemi.com](mailto:orderlit@onsemi.com)

**N. American Technical Support:** 800-282-9855 Toll Free  
USA/Canada  
**Europe, Middle East and Africa Technical Support:**  
Phone: 421 33 790 2910  
**Japan Customer Focus Center**  
Phone: 81-3-5817-1050

**ON Semiconductor Website:** [www.onsemi.com](http://www.onsemi.com)

**Order Literature:** <http://www.onsemi.com/orderlit>

For additional information, please contact your local Sales Representative

## Looking for pricing, stock, or lifecycle information?

Click below to explore more details on WIN SOURCE:

 [View NCV33064D-5R2 on WIN SOURCE](#)

 [ON Semiconductor](#) Information

## Optimize Your Supply Chain with WIN SOURCE Solutions

-  Global Sourcing Solution
-  Obsolete Management
-  Cost Control Management
-  Shortage Management
-  Alternative Solution
-  Excess Inventory Management