

NCT7718W

Nuvoton

Thermal Sensor IC

Date: Jan/11/2013 Revision: 1.1

NCT7718W Datasheet Revision History

	PAGES	DATES	VERSION	MAIN CONTENTS
1		05/26/09	0.2	1 st release
2		01/07/10	0.3	Modified the registers default value and the hardware strapping resistor value.
3		05/02/10	0.4	Modified some specifications and hardware strapping resistor value
4	2, 20	07/21/10	0.5	Update the key specification and add the top marking specification
5		09/15/10	1.0	Update some statements All versions before 1.0 are preliminary versions
6		04/11/11	1.01	Add the taping specification & update the ordering information
7	21	02/09/12	1.02	Add the mold flash spec
8	18	1/11/13	1.1	Add the ESD protection info.

Table of Content-

1.	GENERAL DESCRIPTION	1
2.	FEATURES	1
2.1	Temperature Measurement	1
2.2	Over Temperature	1
2.3	General	1
3.	KEY SPECIFICATIONS	2
4.	PIN CONFIGURATION	2
5.	PIN DESCRIPTION.....	3
5.1	PIN TYPE DISCRPTION	3
5.2	PIN DISCRPTION	3
6.	FUNCTION DESCRIPTION	4
6.1	General Description.....	4
6.2	Access Interface	4
6.2.1	Data write to the internal register	4
6.2.2	Data read from the internal register	4
6.3	Address Setting	5
6.4	Temperature Measurement Data Format.....	5
6.4.1	The local temperature (on-die) data with 8-bit 2`'s complement format	5
6.4.2	The remote temperature data with 11-bit 2`'s complement format.	5
6.5	ALERT# Output.....	6
6.5.1	ALERT# Output Comparator Mode	6
6.5.2	ALERT# Output Interrupt Mode	6
6.5.3	ALERT# Output SMBus alert Mode.....	7
6.5.4	T_CRIT# Output	7
7.	REGISTER SUMMARY	8
7.1	Register Map	8
7.2	Register Detail	9
7.2.1	Register: Local Diode Temperature Readout	9
7.2.2	Register: Remote Diode 1 Temperature Readout (MSB)	9
7.2.3	Register: Alert Status.....	9
7.2.4	Register: Configuration.....	10
7.2.5	Register: Conversion Rate.....	11
7.2.6	Register: Local Diode Temperature Alert Temperature	11
7.2.7	Register: Remote Diode 1 Temperature High Alert Temperature (MSB).....	11
7.2.8	Register: Remote Diode 1 Temperature Low Alert Temperature (MSB)	12
7.2.9	Register: One Shot Conversion	12
7.2.10	Register: Remote Diode 1 Temperature Readout (LSB)	12
7.2.11	Register: Remote Diode 1 Temperature Offset Register (MSB)	12
7.2.12	Register: Remote Diode 1 Temperature Offset Register (LSB)	13

7.2.13	Register: Remote Diode 1 Temperature High Alert Temperature (LSB).....	13
7.2.14	Register: Remote Diode 1 Temperature Low Alert Temperature (LSB)	13
7.2.15	Register: Alert Mask	14
7.2.16	Register: Remote Diode 1 Critical Temperature	15
7.2.17	Register: Local Diode Critical Temperature	15
7.2.18	Register: Critical Temperature Hysteresis	16
7.2.19	Register: Customer Data Log Registers	16
7.2.20	Register: Remote Diode Temperature Filter and Alert Mode Setting.....	16
7.2.21	Register: Chip ID	17
7.2.22	Register: Vendor ID	17
7.2.23	Register: Device ID.....	17
8.	ELECTRICAL CHARACTERISTICS	18
8.1	Absolute Maximum Ratings	18
8.2	DC Characteristics	18
8.3	AC Characteristics.....	19
9.	ORDERING INFORMATION.....	20
10.	TOP MARKING SPECIFICATION	20
11.	TAPING SPECIFICATION	20
12.	PACKAGE DRAWING AND DIMENSIONS.....	21

1. GENERAL DESCRIPTION

NCT7718W is a temperature sensor with one local and one remote sensor; the remote temperature sensor input could be connected to thermal diode or transistor, such as 2N3904. A 10-bit ADC (Analog-to-Digital Converter) is built inside NCT7718W to convert the monitored temperature value with 0.125°C resolution.

Additionally, the NCT7718W supports 2-wire System Management Bus (SMBus™) series interface, and it also provides the hardware thermal alert or system shutdown via ALERT# and T_CRIT# pin.

The NCT7718W is a high precision, low-power consumption IC supporting SMBus™ interface, which is specifically designed for the PC, Notebook applications, and any embedded environments. Its available package is 8-pin MSOP, with the working voltage of 3.3V.

2. FEATURES

2.1 Temperature Measurement

Measure the temperature with high accuracy

One local on-die thermal sensor

One remote temperature sensor with current mode

2.2 Over Temperature

Supports 2 alert outputs : ALERT# and T_CRIT#

T_CRIT# point supports Hardware Power-on setting

ALERT# output supports SMBus™ 2.0 ARA function

2.3 General

I²C® Compatible System Management bus (SMBus™)

3.3V±5% V_{DD} operation

8-pin MSOP Green Package (Halogen-free)

3. KEY SPECIFICATIONS

PARAMETER	RATING
Local temperature range and accuracy	-40°C to +125°C (TA)
	Typ. $\pm 2^{\circ}\text{C}$ (20°C~40°C)
	Max. $\pm 3^{\circ}\text{C}$ (-40°C~125°C) * ¹
Remote temperature range and accuracy	-40°C to +127°C (TD)
	Typ. $\pm 1^{\circ}\text{C}$ (25°C ~70°C)
	Typ. $\pm 2^{\circ}\text{C}$ (-40°C ~127°C)
	Max. $\pm 3^{\circ}\text{C}$ (-40°C~127°C) * ²
Supply voltage	3.3V \pm 5%
Operating supply current	1.2 mA typ.
ADC resolution include sign bit	10 Bits

*1 Guaranteed by design from -40~125 degreeC, 100% tested at 85 degreeC.

*2 Guaranteed by design from -40~127 degreeC, 100% tested at 85 degreeC.

4. PIN CONFIGURATION

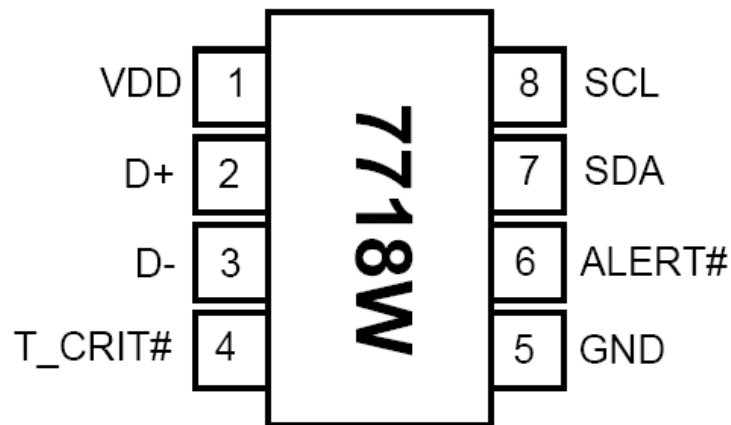

5. PIN DESCRIPTION

5.1 PIN TYPE DISCRIPTION

PIN TYPE	PIN ATTRIBUTE
OD ₁₂	Open-drain output pin with 12 mA sink capability
IN _{ts}	TTL level input pin and Schmitt-trigger
AIN	Input pin (Analog)
P	Power or Ground Pin

5.2 PIN DISCRIPTION

PIN NO.	PIN NAME	I/O	FUNCTION
1	VDD	P	DC Power supply, Voltage input 3.3V±5%
2	D+	AIN	Connect to Thermal Diode Anode
3	D-	AIN	Connect to Thermal Diode Cathode
4	T_CRIT#	OD ₁₂	T_CRIT alarm output, for interrupt or shutdown control
5	GND	P	Power supply ground
6	ALERT#	OD ₁₂	Alarm output, for interrupt control
7	SDA	IN _{ts} / OD ₁₂	SMBus™ bi-directional data
8	SCL	IN _{ts}	SMBus™ Clock

6. FUNCTION DESCRIPTION

6.1 General Description

NCT7718W is SMBus™ interface device to provide on-die temperature sensor and 1 set of thermal inputs for CPU/GPU thermal diode sensor, 2 wire alert signals which ALERT# is for processor event notification and T_CRIT# is for thermal shutdown.

6.2 Access Interface

NCT7718W provides SMBus™ to access the internal register, and supports SMBus™ byte write and byte read protocols.

6.2.1 Data write to the internal register

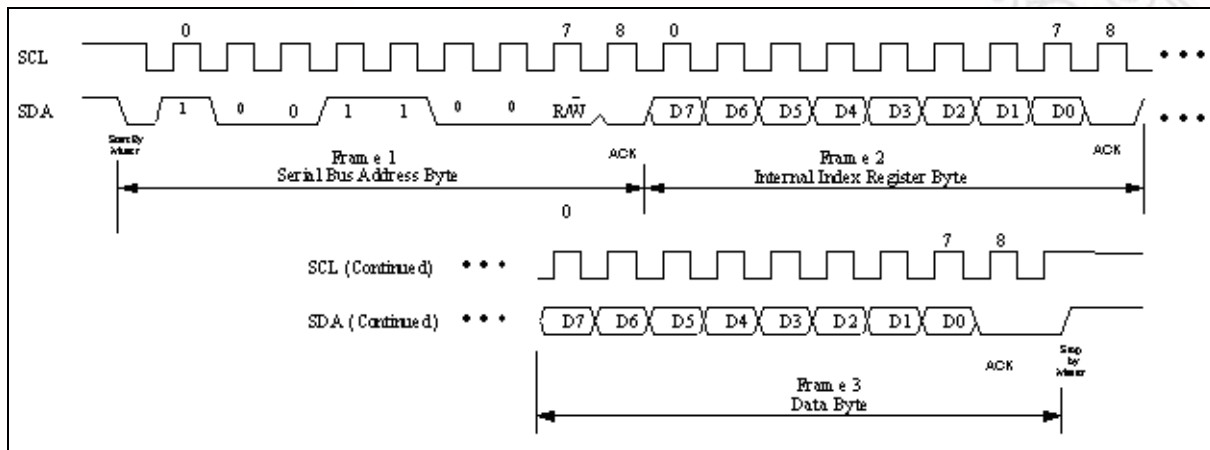

6.2.2 Data read from the internal register

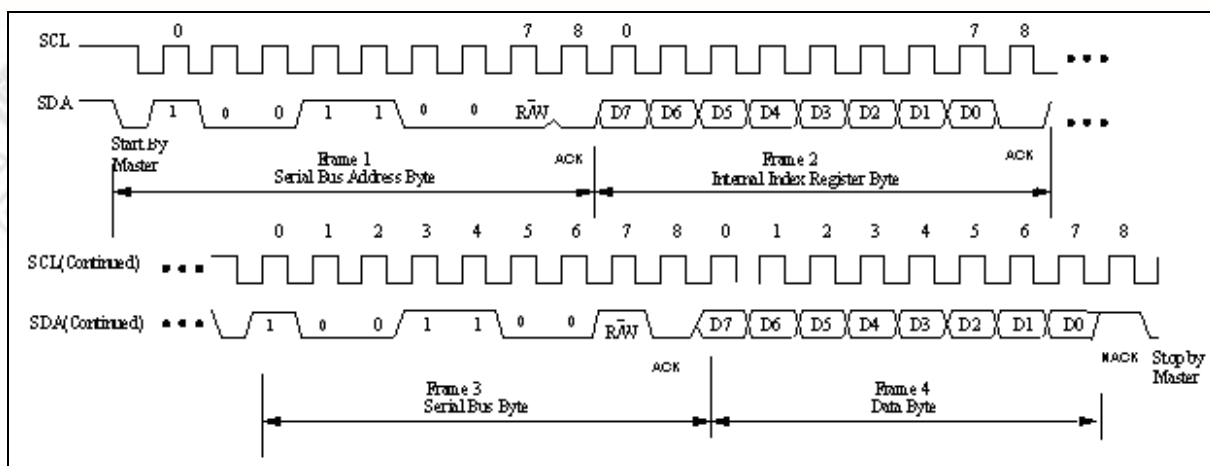

6.3 Address Setting

NCT7718W I²C/ SMBus™ address is 1001100xb (x is R/W bit).

6.4 Temperature Measurement Data Format

6.4.1 The local temperature (on-die) data with 8-bit 2`s complement format.

TEMPERATURE	8-BIT DIGITAL OUTPUT
+127°C	0111,1111
+25°C	0001,1001
+2°C	0000,0010
+1°C	0000,0001
+0°C	0000,0000
- 1°C	1111,1111
- 2°C	1111,1110
- 25°C	1110,0111
- 128°C	1000,0000

6.4.2 The remote temperature data with 11-bit 2`s complement format.

TEMPERATURE	8-BIT DIGITAL OUTPUT HIGH BYTE	3-BIT DIGITAL OUTPUT LOW BYTE
+127.875°C	0111,1111	111X,XXXX
+25.750°C	0001,1001	110X,XXXX
+2.250°C	0000,0010	010X,XXXX
+1.125°C	0000,0001	001X,XXXX
+0.000°C	0000,0000	000X,XXXX
- 1.125°C	1111,1110	111X,XXXX
- 2.250°C	1111,1101	110X,XXXX
- 25.750°C	1110,0110	010X,XXXX
- 127.875°C	1000,0000	001X,XXXX

6.5 ALERT# Output

The NCT7718W ALERT# pin is an active-low open-drain output pin which is triggered when measured temperature exceeds the limitation defined in the limit registers. There are three types of ALERT# output mode: the ALERT# output comparator mode, the ALERT# output interrupt mode, and the ALERT# output SMBus™ ALERT# mode.

6.5.1 ALERT# Output Comparator Mode

Figure 1 shows the mechanism of the ALERT# output comparator mode. In this mode, the ALERT# pin will be alerted if the monitored temperature is out-of-limit and the ALERT# pin keeps low until the temperature goes back to the target range.

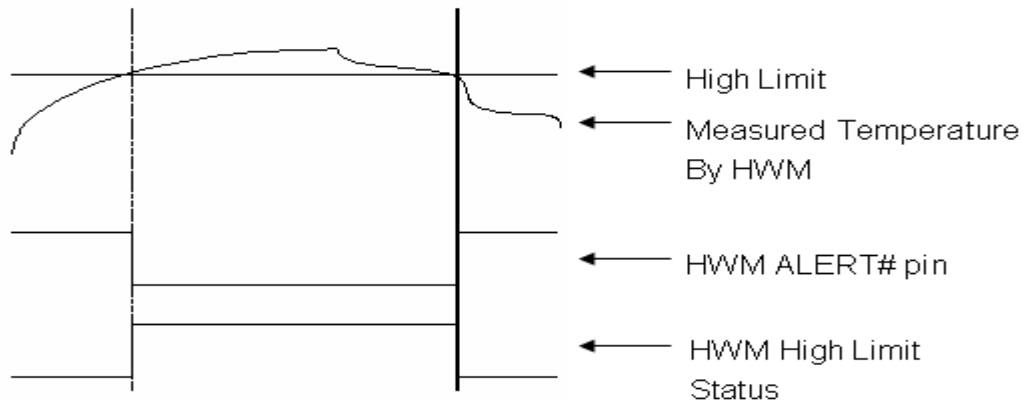

Figure 1

6.5.2 ALERT# Output Interrupt Mode

Figure 2 shows the mechanism of the ALERT# output interrupt mode. In this mode, the NCT7718W will set the ALERT mask bit of Configuration Register during a read of the Status Register if any flag in Status Register, except the ADC_Busy flag and Remote Diode Open flag, is set. This prevents further ALERT# triggering until the master has reset the ALERT mask bit (write 0 to Alert_MSK), at the end of the interrupt service routine. The Status Register flags are cleared only upon a read Status Register command from the master and will be re-alerted at the end of the next temperature conversion if the measured temperature still falls outside of the allowed range.

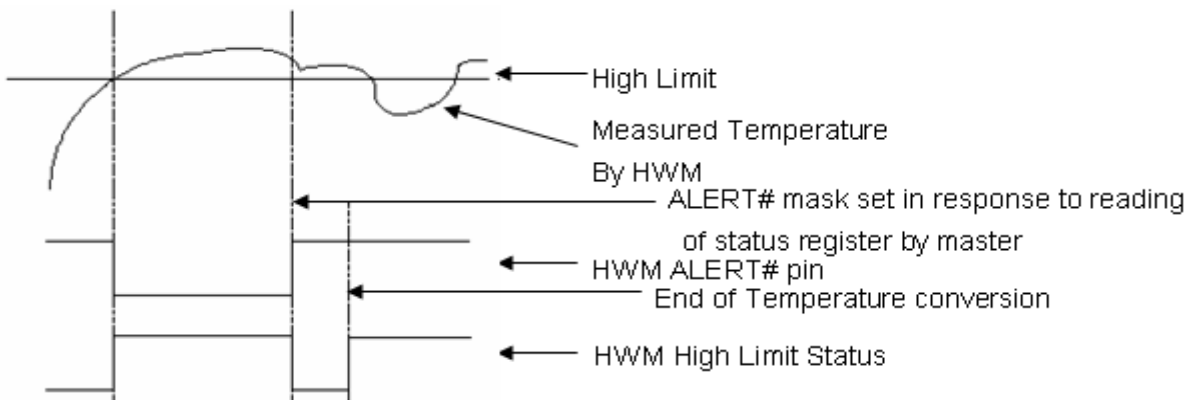

Figure 2

6.5.3 ALERT# Output SMBus alert Mode

Figure 3 shows the mechanism of the ALERT# output SMBus™ alert mode. In this mode, the ALERT# output of the NCT7718W is connected to the SMBus™ alert line which has more than one device connected to it. Through such an implementation, SMBus™ alert mode can assist the master in resolving which slave generates an interrupt. When the measured temperature falls outside of the allowed range, the ALERT# pin will be pulled low and the corresponding alert flags in Status Register will be set to 1. The ALERT mask bit will just be set if there is a read command for Status Register or when SMBus™ ALERT Response Address (ARA) occurs from master (Alert Response Address is 0001100x). Meanwhile, the NCT7718W will generate and return its own address to the master. If the temperature never falls outside of the allowed range, the latched ALERT# pin can release by the reset ALERT mask bit and the latched corresponding alert flags in Status Register can release by reading command for Status Register.

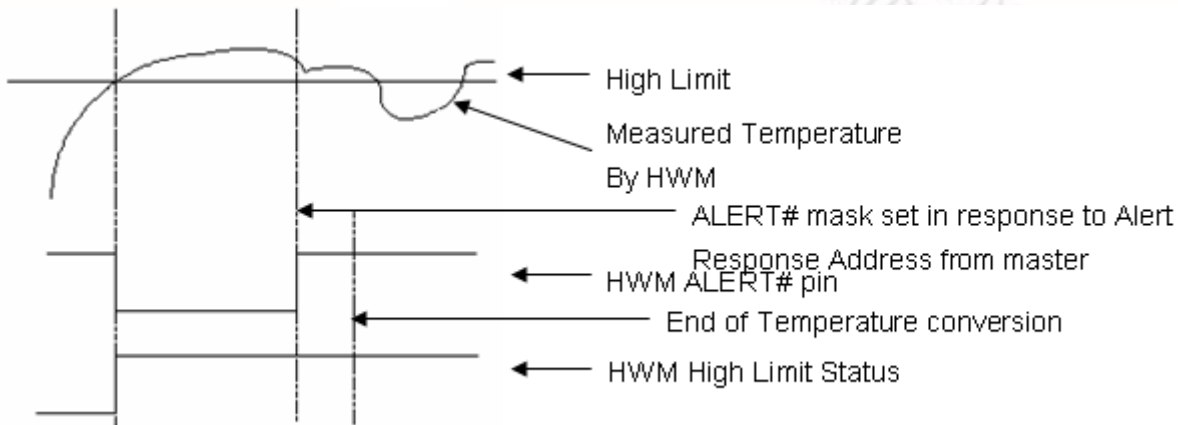

Figure 3

6.5.4 T_CRIT# Output

T_CRIT# output pulls low when the measured temperature exceeds the critical temperature setting. Once the T_CRIT# output pulls low, it will not be set high until the measured temperature is lower than "T_CRIT - TH", where TH is Temperature Hysteresis. Status Register will not be reset until it is read and the temperature conversion falls below the T_CRIT set point, the ALERT-MSK bit of Configuration Register will be set after Status Register read. Figure 4 shows this mechanism.

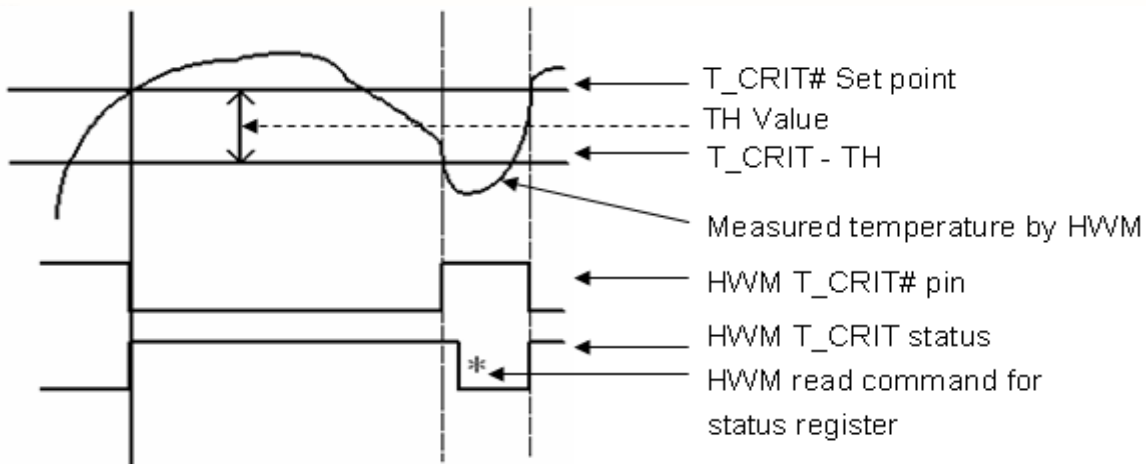

Figure 4

7. REGISTER SUMMARY

7.1 Register Map

Idx	Register Name	Attr	Dft	7	6	5	4	3	2	1	0
0	LDT Readout	RO	00	MNTREG_LT[7:0]							
1	RT1 Temp MSB	RO	00	MNTREG_RT1[10:3]							
2	Alert Status	RO	00	ADC_Busy	STS_LTHA	Reserved	STS_RT1HA	STS_RT1LA	STS_RT1O	STS_RT1C	STS_LC
3	Configuration [R]	RW	25	ALERT_MSK	STOP_Mnt	Reserved		Reserved	EN_RT1	EN_WTC	EN_FaultQueue
4	Conversion Rate [R]	RW	08	Reserved				ConvRate[3:0]			
5	LT Alert Temp [R]	RW	46	LT_HAT[7:0]							
6	Reserved			Reserved							
7	RT1 High Alert Temp MSB [R]	RW	46	RT1_HAT[10:3]							
8	RT1 Low Alert Temp MSB [R]	RW	D8	RT1_LAT[10:3]							
9	Configuration [W]	RW	25	ALERT_MSK	STOP_Mnt	Reserved		Reserved	EN_RT1	EN_WTC	EN_FaultQueue
A	Conversion Rate [W]	RW	08	Reserved				ConvRate[3:0]			
B	LT Alert Temp [W]	RW	46	LT_HAT[7:0]							
C	Reserved			Reserved							
D	RT1 High Alert Temp MSB [W]	RW	46	RT1_HAT[10:3]							
E	RT1 Low Alert Temp MSB [W]	RW	D8	RT1_LAT[10:3]							
F	One Shot Conversion	WO	FF								
10	RT1 Temp LSB	RO	00	MNTREG_RT1[2:0]			Reserved				
11	RT1 Offset Temp MSB	RW	00	OFFSET_RT1[10:3]							
12	RT1 Offset Temp LSB	RW	00	OFFSET_RT1[2:0]			Reserved				
13	RT1 High Alert Temp LSB	RW	00	RT1_HAT[2:0]			Reserved				
14	RT1 Low Alert Temp LSB	RW	00	RT1_LAT[2:0]			Reserved				
16	Alert Mask	RW	07	MSK_LTH	Reserved		MSK_RT1H	MSK_RT1L	Reserved	MSK_RT1C	MSK_LC
19	RT1 Critical Temp	RW	-	RT1_CT[7:0]							
20	LT Critical Temp	RW	-	LT_CT[7:0]							
21	Critical Temp Hysteresis	RW	0A	Reserved				CTH[4:0]			
2D	Customer Data Log Register 1	RW	00	CustomerLogReg1[7:0]							
2E	Customer Data Log Register 2	RW	00	CustomerLogReg2[7:0]							
2F	Customer Data Log Register 3	RW	00	CustomerLogReg3[7:0]							
BF	RT Filter & Alert mode	RW	00	Reserved					RT1F		Alert_MD
FD	CID (Chip ID)	RO	50	50h							
FE	VID (Vendor ID)	RO	50	50h							

FF	DID (Device ID)	RO	90	90H				
----	-----------------	----	----	-----	--	--	--	--

7.2 Register Detail

7.2.1 Register: Local Diode Temperature Readout

Location : Address 00h

Type : Read Only

Power on default value : 00

BIT	7	6	5	4	3	2	1	0
NAME	Local Diode Temperature Readout Value. The real temperature value calculation is referred to TEMPERATURE MEASUREMENT DATA FORMAT.							
VALUE	SIGN	64	32	16	8	4	2	1

7.2.2 Register: Remote Diode 1 Temperature Readout (MSB)

Location : Address 01h

Type : Read Only

Power on default value : 00

BIT	7	6	5	4	3	2	1	0
NAME	Remote Diode 1 Temperature Readout Value. The real temperature value calculation is referred to TEMPERATURE MEASUREMENT DATA FORMAT.							
VALUE	SIGN	64	32	16	8	4	2	1

7.2.3 Register: Alert Status

Location : Address 02h

Type : Read Only

Power on default value : 00

BIT	7	6	5	4	3	2	1	0
NAME	ADC_Busy	STS_LTHA	Reserved	STS_RT1HA	STS_RT1LA	STS_RT1O	STS_RT1C	STS_LC
DEFAULT	0	0		0	0	0	0	0

BIT	FLAG NAME	DESCRIPTION
7	ADC_Busy	If set to '1' indicates ADC is busy converting.
6	STS_LTHA	If set to '1' indicates a measured Local Diode Temperature Higher than Local High set point (High Limit).
5	Reserved	
4	STS_RT1HA	If set to '1' indicates a measured Remote Diode1 Temperature higher than Remote High set point (High Limit).
3	STS_RT1LA	If set to '1' indicates a measured Remote Diode1 Temperature lower than Remote Low set point (Low Limit).

BIT	FLAG NAME	DESCRIPTION
2	STS_RT1O	If set to '1' indicates a Remote Diode1 disconnect.
1	STS_RT1C	If set to '1' indicates a Remote Diode1 Critical Temperature alarm.
0	STS_LC	If set to '1' indicates a Local Diode Critical Temperature alarm.

7.2.4 Register: Configuration

Location : Address 03h and 09h

Type : Read/Write

Power on default value : 05

BIT	7	6	5	4	3	2	1	0
NAME	ALERT_MSK	STOP_Mnt	Reserved			EN_RT1	EN_WTC	EN_Fault Queue
DEFAULT	0	0				1	0	1

BIT	DESCRIPTION
7	ALERT_MSK – ALERT# function is enable 0 = Enable 1 = Disable
6	STOP_Mnt – Stop Monitor and entry Standby 0 = Monitor 1 = Stop Monitor
2	EN_RT1 – Enable Remote Diode 1 monitoring. 0 = Disable 1 = Enable
1	EN_WTC– Enable Override POR Value of Critical Temperature 0 = Disable 1 = Enable
0	EN_Fault Queue–Enable Fault Queue function. 0 = Disable. ALERT# and T_CRIT# will be generated if monitor result of any channel is above or below high/low set point. 1 = Enable. ALERT# and T_CRIT# will be generated if monitor result of any channel is three successive times above or below high/low set point.

7.2.5 Register: Conversion Rate

Location : Address 04h and 0Ah

Type : Read/Write

Power on default value : 08

BIT	7	6	5	4	3	2	1	0
NAME	Reserved				ConvRate			
DEFAULT					1	0	0	0

BIT<D7:D0>	FREQUENCY/TIME
00h	0.0625Hz / 16sec
01h	0.125Hz / 8sec
02h	0.25Hz / 4sec
03h	0.5Hz / 2sec
04h	1Hz / 1sec
05h	2Hz / 0.5sec
06h	4Hz / 0.25sec
07h	8Hz / 0.125sec
08h	16Hz / 0.0625sec
09h-FFh	Reserved

7.2.6 Register: Local Diode Temperature Alert Temperature

Location : Address 05h and 0Bh

Type : Read/Write

Power on default value : 46

BIT	7	6	5	4	3	2	1	0
NAME	LDT Alert Temperature							
VALUE	SIGN	64	32	16	8	4	2	1
DEFAULT	46h (70°C)							

7.2.7 Register: Remote Diode 1 Temperature High Alert Temperature (MSB)

Location : Address 07h and 0Dh

Type : Read/Write

Power on default value : 46

BIT	7	6	5	4	3	2	1	0
NAME	RT1 High Alert Temperature High Byte							
VALUE	SIGN	64	32	16	8	4	2	1
DEFAULT	46h (70°C)							

7.2.8 Register: Remote Diode 1 Temperature Low Alert Temperature (MSB)

Location : Address 08h and 0Eh

Type : Read/Write

Power on default value : D8

BIT	7	6	5	4	3	2	1	0
NAME	RT1 Low Alert Temperature High Byte							
VALUE	SIGN	64	32	16	8	4	2	1
DEFAULT	D8h (-40°C)							

7.2.9 Register: One Shot Conversion

Location : Address 0Fh

Type : Write Only

BIT	DESCRIPTION
7-0	One Shot Conversion – When enter Stop Monitor state, to fill any value into this register will trigger one temperature conversion cycle.

7.2.10 Register: Remote Diode 1 Temperature Readout (LSB)

Location : Address 10h

Type : Read Only

Power on default value : 00

BIT	7	6	5	4	3	2	1	0
NAME	Remote Diode 1 Temperature Readout Value. The real temperature value calculation is referred to TEMPERATURE MEASUREMENT DATA FORMAT.			Reserved				
VALUE	0.5	0.25	0.125	0				

7.2.11 Register: Remote Diode 1 Temperature Offset Register (MSB)

Location : Address 11h

Type : Read/Write

Power on default value : 00

BIT	7	6	5	4	3	2	1	0
NAME	RT1 OFFSET VALEU High Byte							
VALUE	SIGN	64	32	16	8	4	2	1
DEFAULT	00h							

7.2.12 Register: Remote Diode 1 Temperature Offset Register (LSB)

Location : Address 12h

Type : Read/Write

Power on default value : 00

BIT	7	6	5	4	3	2	1	0
NAME	RT1 OFFSET VALUE Low Byte							
VALUE	0.5	0.25	0.125					
DEFAULT	00h							

7.2.13 Register: Remote Diode 1 Temperature High Alert Temperature (LSB)

Location : Address 13h

Type : Read/Write

Power on default value : 00

BIT	7	6	5	4	3	2	1	0
NAME	RT1 High Alert Temperature Low Byte							
VALUE	0.5	0.25	0.125					
DEFAULT	00h							

7.2.14 Register: Remote Diode 1 Temperature Low Alert Temperature (LSB)

Location : Address 14h

Type : Read/Write

Power on default value : 00

BIT	7	6	5	4	3	2	1	0
NAME	RT1 Low Alert Temperature Low Byte							
VALUE	0.5	0.25	0.125					
DEFAULT	00h							

7.2.15 Register: Alert Mask

Location : Address 16h

Type : Read/Write

Power on default value : 07

BIT	7	6	5	4	3	2	1	0
NAME	MSK_LTH	Reserved		MSK_RT 1H	MSK_RT 1L	Reserved	MSK_RT1 C	MSK_ LC
DEFAULT	0			0	0		1	1

BIT	DESCRIPTION
7	MSK_LTH – Local Diode Temperature High Alert Mask 0 = Alert is not masked 1 = Alert is masked
4	MSK_RT1H– Remote Diode 1 Temperature High Alert Mask 0 = Alert is not masked 1 = Alert is masked
3	MSK_RT1L– Remote Diode 1 Temperature Low Alert Mask 0 = Alert is not masked 1 = Alert is masked
1	MSK_RT1C– Remote Diode 1 Temperature Critical Mask 0 = Alert is not masked 1 = Alert is masked
0	MSK_LC– Local Diode Temperature Critical Mask 0 = Alert is not masked 1 = Alert is masked

7.2.16 Register: Remote Diode 1 Critical Temperature

Location : Address 19h

Type : Read/Write

Power on default value : Power on strapping after power up 100ms

BIT	7	6	5	4	3	2	1	0
NAME	RT1 Critical Temperature The format of Temperature is 8-bit 2's complement and the range is -128°C~127°C.							
VALUE	SIGN	64	32	16	8	4	2	1
DEFAULT	Hardware Strapping							

The default value is trapping after power up 100ms by different pull-up resistors of T_CRIT# and ALERT# pin:

TEMPERATURE (°C)		T_CRIT#				
		2KΩ	7.5KΩ	10.5KΩ	14KΩ	18.7KΩ
ALERT#	2KΩ	77	87	97	107	117
	7.5KΩ	79	89	99	109	119
	10.5KΩ	81	91	101	111	121
	14KΩ	83	93	103	113	123
	18.7KΩ	85	95	105	115	125

7.2.17 Register: Local Diode Critical Temperature

Location : Address 20h

Type : Read/Write

Power on default value : Power on strapping after power up 100ms

BIT	7	6	5	4	3	2	1	0
NAME	Local Diode Critical Temperature The format of Temperature is 8-bit 2's complement and the range is -128°C~127°C.							
VALUE	SIGN	64	32	16	8	4	2	1
DEFAULT	Hardware Strapping							

The default value is trapping after power up 100ms by different pull-up resistors of T_CRIT# and ALERT# pin:

TEMPERATURE (°C)		T_CRIT#				
		2KΩ	7.5KΩ	10.5KΩ	14KΩ	18.7KΩ
ALERT#	2KΩ	77	87	97	107	117
	7.5KΩ	79	89	99	109	119
	10.5KΩ	81	91	101	111	121
	14KΩ	83	93	103	113	123
	18.7KΩ	85	95	105	115	125

7.2.18 Register: Critical Temperature Hysteresis

Location : Address 21h

Type : Read/Write

Power on default value : 0A

BIT	7	6	5	4	3	2	1	0
NAME	Critical Temperature Hysteresis The format of Temperature is 5-bit integer and the range is 0°C~31°C.							
VALUE				16	8	4	2	1
DEFAULT	0Ah (10°C)							

7.2.19 Register: Customer Data Log Registers

Location : Address 2Dh 2Eh 2Fh

Type : Read/Write

Power on default value : 00

BIT	7	6	5	4	3	2	1	0
NAME	Customer Data Log Register							
DEFAULT	00h							

7.2.20 Register: Remote Diode Temperature Filter and Alert Mode Setting

Location : Address BFh

Type : Read/Write

Power on default value : 00

BIT	7	6	5	4	3	2	1	0
NAME	Reserved				RT1F		ALERT_MD	
DEFAULT	00h							

BIT	DESCRIPTION
2-1	RT1F – Remote diode temperature 1 filter setting 00 = No filter selected 01 or 10 = Filter level 1 selected 11 = Filter level 2 selected
0	ALERT_MD – ALERT mode configuration 0 = Interrupt or SMBus alert mode 1 = Comparator mode

7.2.21 Register: Chip ID

Location : Address FDh

Type : Read Only

Power on default value : 50

BIT	DESCRIPTION
7-0	Chip ID Chip ID of NCT7718W is 50h

7.2.22 Register: Vendor ID

Location : Address FEh

Type : Read Only

Power on default value : 50

BIT	DESCRIPTION
7-0	Vendor ID Vendor ID of NCT7718W is 50h

7.2.23 Register: Device ID

Location : Address FFh

Type : Read Only

Power on default value : 9x

BIT	DESCRIPTION
7-0	Device ID Device ID of NCT7718W is 9xh (x=0,1,2.....)

8. ELECTRICAL CHARACTERISTICS

8.1 Absolute Maximum Ratings

PARAMETER		RATING	UNIT
Power Supply Voltage		3.3V \pm 5%	V
Input Voltage		-0.3 to +3.6	V
Operating Temperature		-40 to +125	$^{\circ}$ C
Storage Temperature		-55 to +150	$^{\circ}$ C
ESD Protection	Human Body Mode	2	KV
	Machine Mode	200	V
	Latch-up	100	mA

Note: Exposure to conditions beyond those listed under Absolute Maximum Ratings may adversely affect the life and reliability of the device.

8.2 DC Characteristics

($T_a = 0^{\circ}$ C to 70° C, VDD = 3.3V \pm 5%, GND = 0V)

PARAMETER	SYM.	MIN.	TYP.	MAX.	UNIT	CONDITIONS
OD ₁₂ – Open-drain output pin with source-sink capability of 12 mA						
Output Low Voltage	V _{OL}			0.4	V	I _{OL} = 12 mA
OUT ₁₂ - Output buffer pin with source-sink capability of 12 mA						
Output Low Voltage	V _{OL}			0.4	V	I _{OL} = 12 mA
Output High Voltage	V _{OH}	2.4			V	I _{OH} = -12 mA
IN _{ts} - TTL level Schmitt-triggered input pin						
Input Low Voltage	V _{IL}			0.8	V	VDD = 3.3V
Input High Voltage	V _{IH}	2.0			V	VDD = 3.3V
Input High Leakage	I _{LIH}			+10	μ A	VIN=3.3V
Input Low Leakage	I _{LIL}			-10	μ A	VIN=0V

8.3 AC Characteristics

SMBus™ Interface

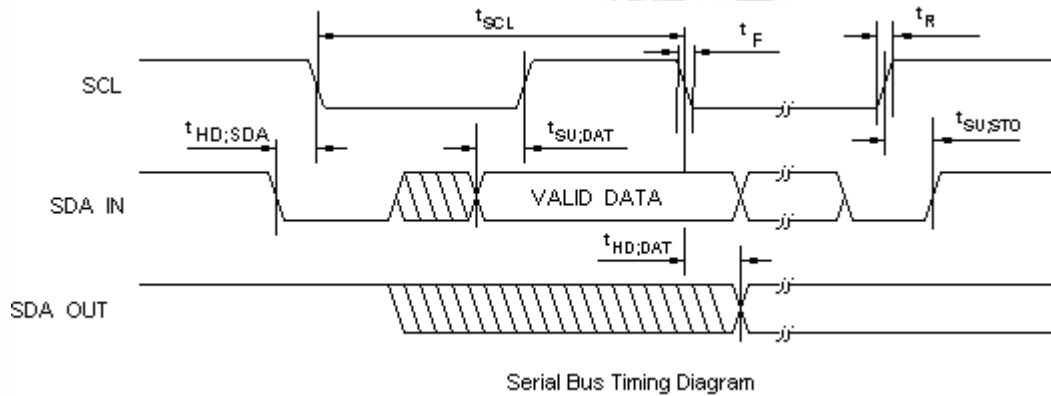

PARAMETER	SYMBOL	MIN.	MAX.	UNIT
SCL clock period	t_{SCL}	2.5		uS
Start condition hold time	$t_{HD;SDA}$	1.5		uS
Stop condition setup-up time	$t_{SU;STO}$	1		uS
DATA to SCL setup time	$t_{SU;DAT}$	120		nS
DATA to SCL hold time	$t_{HD;DAT}$	5		nS
SCL and SDA rise time	t_R		1.0	uS
SCL and SDA fall time	t_F		300	nS

9. ORDERING INFORMATION

PART NO.	PACKAGE	SHIPPING SHAPE	MOQ	PRODUCTION FLOW
NCT7718W	MSOP, 8pin Green package	Tape & Reel	4,000 units	Commercial, 0°C to +70°C

10. TOP MARKING SPECIFICATION



1st line: Part number: **7718W** means NCT7718W

2nd line: Assembly tracking code

0 22 : packages made in year 2010, week 22

G: Assembly house code

B: Product version

11. TAPING SPECIFICATION

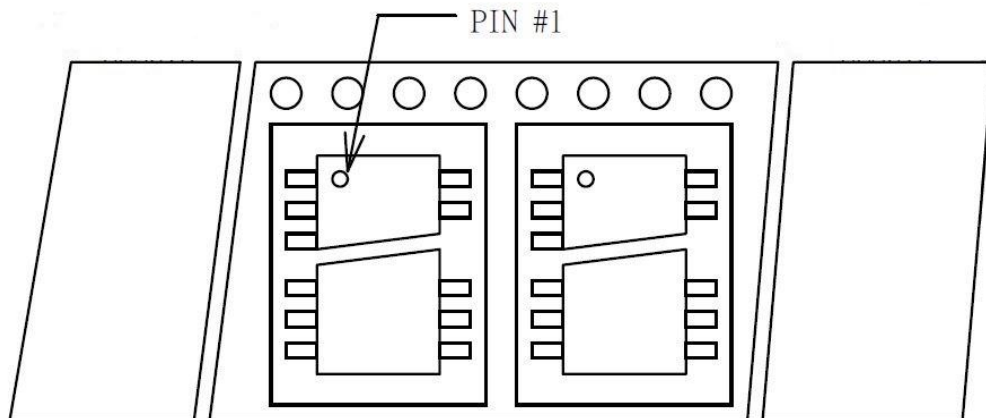

FEEDING DIRECTION →

12. PACKAGE DRAWING AND DIMENSIONS

MSOP-8L 3 X 3mm

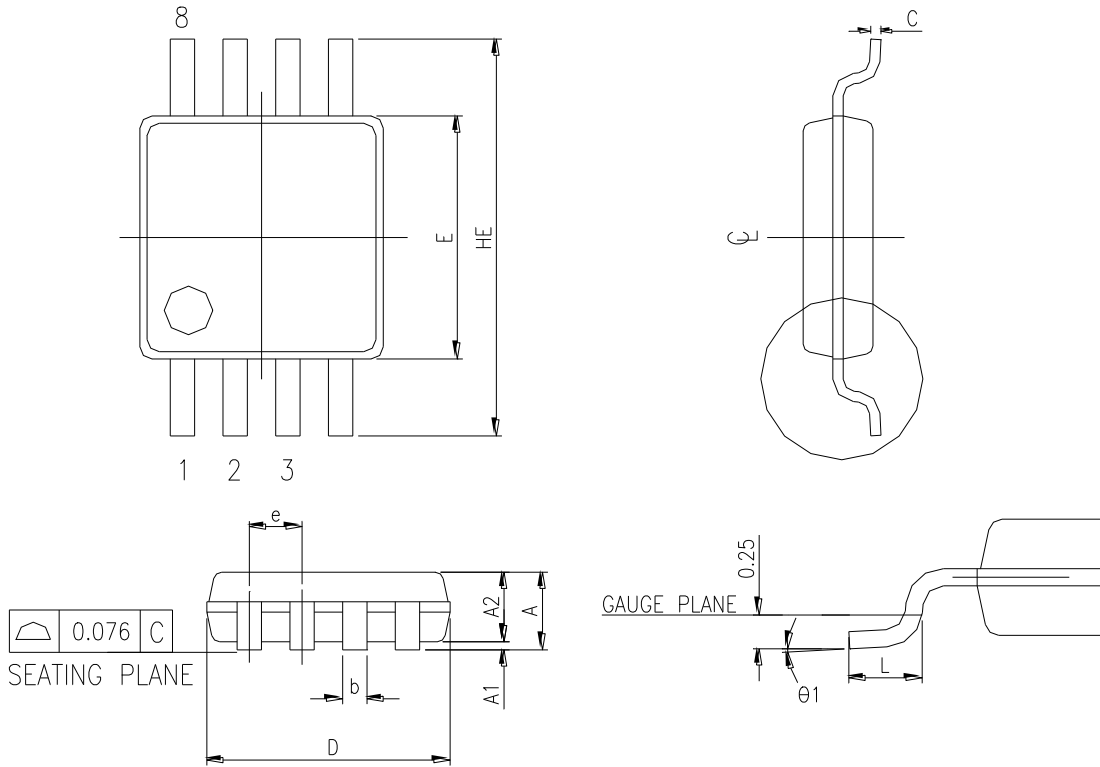

CONTROLLING DIMENSION : MILLIMETERS

SYMBOL	DIMENSION IN MM			DIMENSION IN INCH		
	MIN.	NOM.	MAX.	MIN.	NOM.	MAX.
A	---	---	1.10	---	---	0.043
A1	0.05	---	0.15	0.002	---	0.006
A2	0.81	0.86	0.91	0.032	0.034	0.036
c	0.13	---	0.23	0.005	---	0.009
b	0.25	---	0.40	0.0098	---	0.0157
D	2.90	3.00	3.10	0.114	0.118	0.122
E	2.90	3.00	3.10	0.114	0.118	0.122
HE	4.90 BSC			0.193 BSC		
L	0.445	0.55	0.648	0.0175	0.0217	0.0255
theta1	0°		6°	0°		6°
e	0.65 BSC			0.026 BSC		

Note:

1. Mold Flash of Protrusion shall not exceed 0.25mm (0.010")

Important Notice

Nuvoton Products are neither intended nor warranted for usage in systems or equipment, any malfunction or failure of which may cause loss of human life, bodily injury or severe property damage. Such applications are deemed, "Insecure Usage".



Insecure usage includes, but is not limited to: equipment for surgical implementation, atomic energy control instruments, airplane or spaceship instruments, the control or operation of dynamic, brake or safety systems designed for vehicular use, traffic signal instruments, all types of safety devices, and other applications intended to support or sustain life.

All Insecure Usage shall be made at customer's risk, and in the event that third parties lay claims to Nuvoton as a result of customer's Insecure Usage, customer shall indemnify the damages and liabilities thus incurred by Nuvoton.

Please note that all data and specifications are subject to change without notice.
All the trademarks of products and companies mentioned in this datasheet belong to their respective owners.

Looking for pricing, stock, or lifecycle information?

Click below to explore more details on WIN SOURCE:

-  [View NCT7718W TR on WIN SOURCE](#)
-  [Nuvoton Technology Corporation of America Information](#)

Optimize Your Supply Chain with WIN SOURCE Solutions

-  Global Sourcing Solution
-  Obsolete Management
-  Cost Control Management
-  Shortage Management
-  Alternative Solution
-  Excess Inventory Management