



**THE DATASHEET OF
NCP5008DMR2G**



NCP5008, NCP5009

Backlight LED Boost Driver

The NCP5008/NCP5009 is a high efficiency boost converter operating in current loop control mode to drive Light Emitting Diode. The current mode regulation allows a uniform brightness of the LEDs.

Features

- 2.7 to 6.0 V Input Voltage Range
- Output Voltage from V_{bat} to 15 V
- 3.0 μ A Quiescent Supply Current
- Automatically LEDs Current Matching
- No External Sense Resistor
- Includes Dimming Function
- Programmable or Automatic Current Output Mode
- LOCAL or REMOTE Control Facility
- Photo Transistor Sense Feedback Input
- Inductor Based Converter brings High Efficiency
- Low Noise DC/DC Converter
- All Pins are Fully ESD Protected
- Pb-Free Package is Available

Typical Applications

- LED Display Back Light Control
- High Efficiency Step Up Converter

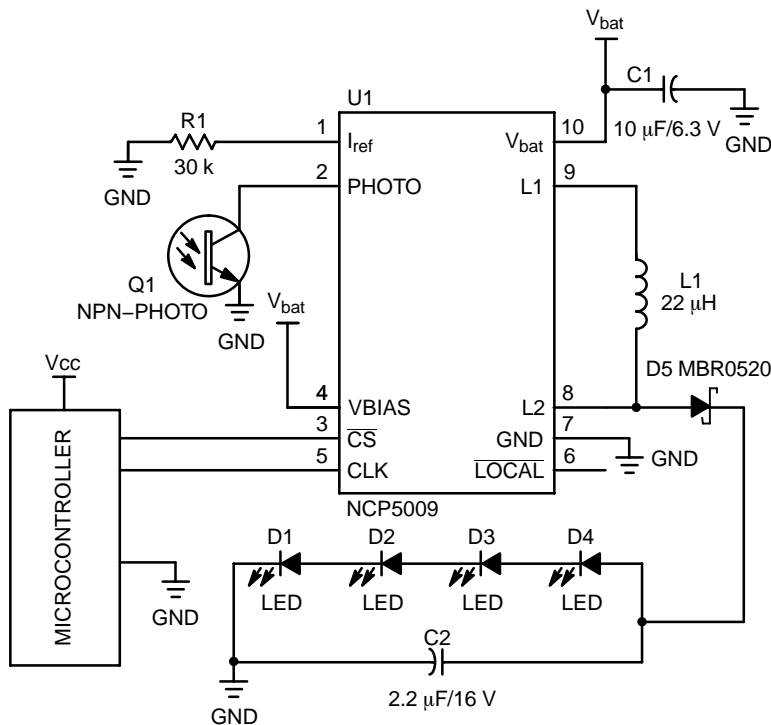

Figure 1. Typical Battery Powered LED Boost Driver



ON Semiconductor®

<http://onsemi.com>

MARKING DIAGRAM

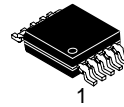

Micro 10
DM SUFFIX
CASE 846B

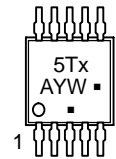

5Tx = Device Number
x = 8 or 9

A = Assembly Location

Y = Year

W = Work Week

▪ = Pb-Free Package

(Note: Microdot may be in either location)

PIN CONNECTIONS

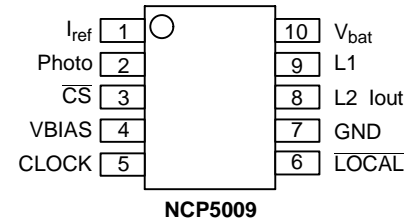
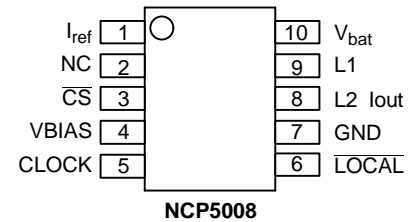

ORDERING INFORMATION

Device	Package	Shipping†
NCP5008DMR2	Micro 10	4000 / Tape & Reel
NCP5008DMR2G	Micro 10 (Pb-Free)	4000 / Tape & Reel
NCP5009DMR2	Micro 10	4000 / Tape & Reel

†For information on tape and reel specifications, including part orientation and tape sizes, please refer to our Tape and Reel Packaging Specifications Brochure, BRD8011/D.

NCP5008, NCP5009

BACK LIGHT WHITE LED CURRENT DRIVE CONTROLLER

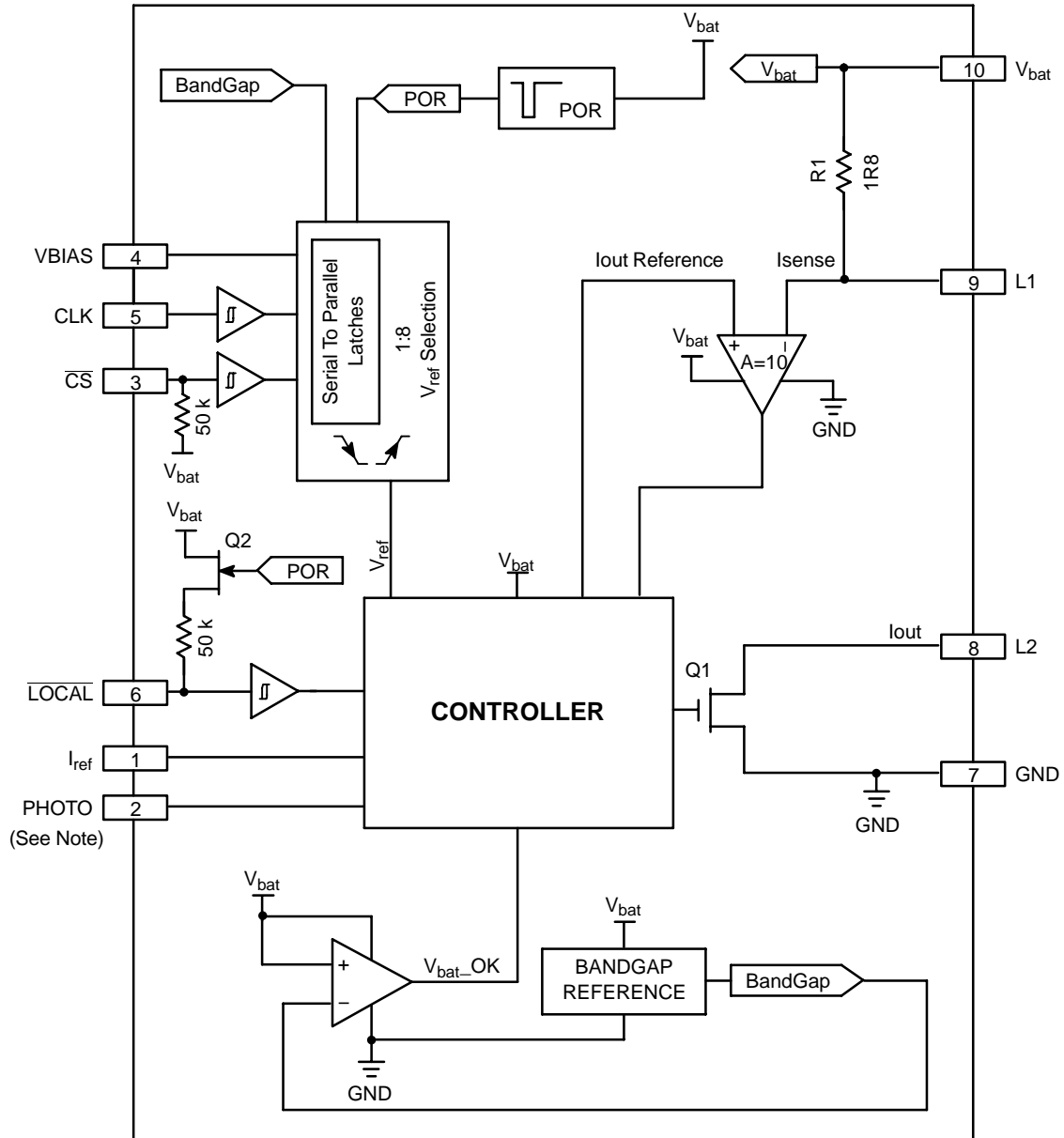

NOTE: This functionality is NOT implemented on the NCP5008 type.

Figure 2. Block Diagram

NCP5008, NCP5009

PIN FUNCTION DESCRIPTION

Pin	Symbol	Type	Description
1	I_{ref}	INPUT	This pin provides the output current range adjustment by means of a resistor connected to ground. The current output tolerance depends upon the accuracy of this resistor. Using a $\pm 1\%$ metal film resistor, or better, yields the best output current accuracy.
2	PHOTO	SIGNAL	This pin provides an access to the output current control loop for the NCP5009 version. The current sunk to ground from this pin is subtracted from the output current mirror. Primary use is the ambient light automatic adjustment by means of an external photo transistor connected across this pin and ground. The output current decreases as the ambient light increases. The internal circuit provides a 1/1 current ratio with the I_{ref} defined by the resistor connected from pin 1 to ground. This current shall be limited to 65 μA . This functionality is NOT implemented on the NCP5008 type.
3	\overline{CS}	INPUT	Negative going Chip Select logic input. This pin is used to select the NCP5008/ NCP5009 and validate the clock/data when $\overline{CS} = Low$. The internal shift register is automatically clear to zero upon the falling edge, thanks to a 20 ns built-in one shoot. The built-in pull-up resistor disables the device when the \overline{CS} pin is left open.
4	VBIAS	POWER	This pin should be connected to V_{bat} .
5	CLOCK	INPUT	The clock signal connected to this pin is used to serially shift right the internal preset high logic level. The clock is valid between the falling edge and until the rising edge of the \overline{CS} . There is neither a feedback nor an overflow control. If the clock count exceeds 8 bits, the internal register is clear, the output current is forced to zero and the device comes back to the shutdown mode.
6	\overline{LOCAL}	INPUT	This pin is used to select the mode of operation. <ul style="list-style-type: none"> When $\overline{LOCAL} = High$ or Open, the chip is controlled by two digital lines: \overline{CS} and CLOCK. The output current is programmed by the logic control of these pins, allowing a current adjustment within the range defined by the I_{ref} resistor. When $\overline{LOCAL} = Low$, the chip is turned ON /OFF by means of the \overline{CS} line, the CLOCK pins being deactivated. The output current is constant, as defined by the I_{ref} resistor value. In order to minimize the standby current a dynamic pull-up resistor is activated when POR is High, this pull-up resistor being disconnected when $\overline{LOCAL} = Low$.
7	GND	POWER	This pin is the system ground for the NCP5008/NCP5009 and carries both the Power and the Digital signals. High quality ground must be provided to avoid spikes and/or uncontrolled operation. Care must be observed to avoid high-density current flow in a limited PCB copper track.
8	L2	POWER	This pin is the power side of the external inductor and must be connected either to the external Schottky diode (see Figure 22) or directly to one external LED (see Figure 23). It provides the output current to the load. Since the boost converter operates in a current loop mode, the output voltage can range up to +15 V but shall not extend this limit. The user must make sure this voltage will not be exceeded during the normal operation of this part. An external low cost ceramic capacitor (2.2 $\mu F/16 V$, ESR < 100 m Ω) is recommended to smooth the current flowing into the diode(s), thus limiting the noise created by the fast transients present in this circuitry. Care must be observed to avoid EMI though the PCB copper tracks connected to this pin.
9	L1	POWER	The return side of the external inductor shall be connected to this pin. Typical application will use a 22 μH , size 1210, to handle the 2.8 to 364 mA max range. On the other hand, when the desired output current is above 20 mA, the inductor shall have an ESR < 1.0 Ω . The output current tolerance can be improved by using a larger inductor value.
10	V_{bat}	POWER	The external voltage supply is connected to this pin. A high quality reservoir capacitor must be connected across pin 10 and Ground to achieve the specified output voltage parameters. A 10 $\mu F/6.3 V$, low ESR capacitor must be connected as close as possible across pin 10 and ground pin 7. The X5R ceramic types are recommended.

NCP5008, NCP5009

Table 1. Shift Register Bits Assignment and Functions

SetReg shift register (Note: The register content is latched upon \overline{CS} positive going).

	B7	B6	B5	B4	B3	B2	B1
Bn Value After POR	0	0	0	0	0	0	0
Iout Peak (mA)	$I_{ref} * k * 7.5$	$I_{ref} * k * 6.5$	$I_{ref} * k * 5.5$	$I_{ref} * k * 4.5$	$I_{ref} * k * 3.5$	$I_{ref} * k * 2.5$	$I_{ref} * k * 1.5$

LOCAL	CLOCK	\overline{CS}	B1–B7	Output Current
L	X	H	X	0
L	X	L	X	$I_{ref} * k$
H or Open	X	H	No Change	$I_{ref} * k * (Bn + 0.5)$
H or Open	↓	L	No Change	$I_{ref} * k * (Bn + 0.5)$
H or Open	↑	L	$Q_{data} \rightarrow Bn$	$I_{ref} * k * (Bn + 0.5)$

The register is clear to 0 during the first 20 ns following the \overline{CS} falling edge.

Note:

Coefficient Value (internal ratio): $k = 746$

Maximum output peak current @ $B7 = 1$ and $I_{photo} = 0 \mu A$: $I_{out\ peak} = I_{ref} * (7 + 0.5) * 746 = I_{ref} * 5595$

$$I_{ref} = \frac{V_{ref}}{R1} = \frac{1.24\ V}{R1}$$

MAXIMUM RATINGS

Rating	Symbol	Value	Unit
Power Supply	V_{bat}, V_{BIAS}	7.0	V
Output Power Supply Voltage Compliance	V_{L2}	16	V
Digital Input Voltage Digital Input Current	CLK, \overline{CS}	$-0.3 < V < V_{bat} + 3.0\ V$ 1.0	V mA
Human Body Model: $R = 1500\ \Omega, C = 100\ pF$	ESD	± 2.0	kV
Machine Model	ESD	± 200	V
Micro 10 Package Power Dissipation @ $T_A = +85^\circ C$ Thermal Resistance, Junction-to-Air	P_D R_{Thja}	200 200	mW $^\circ C/W$
Operating Ambient Temperature Range	T_A	-25 to +85	$^\circ C$
Operating Junction Temperature Range	T_J	-25 to +125	$^\circ C$
Maximum Junction Temperature	T_{Jmax}	+150	$^\circ C$
Storage Temperature Range	T_{stg}	-65 to +150	$^\circ C$

Stresses exceeding Maximum Ratings may damage the device. Maximum Ratings are stress ratings only. Functional operation above the Recommended Operating Conditions is not implied. Extended exposure to stresses above the Recommended Operating Conditions may affect device reliability.

NCP5008, NCP5009

POWER SUPPLY SECTION (–25°C to +85°C ambient temperature, unless otherwise noted.)

Rating	Pin	Symbol	Min	Typ	Max	Unit
Power Supply	10	V_{bat}	2.7	–	6.0	V
Power Supply Threshold Startup Voltage	10	V_{batThr}	–	2.3	2.7	V
Output Load Voltage Compliance	8	V_{out}	–	–	15.0	V
Pulsed Current Regulation Range	8	I_{out}	0	–	400	mA
Continuous DC Current in the Load	8	I_{out}	–	–	75	mA
Output Pulsed Current Tolerance @ $V_{bat} = 3.6$ V, $L1 = 22$ μ H/0.71 Ω , $R_{ref} \pm 1\%$, $I_{LED} = 20$ mA (Note 1)	8	I_{out}	–	± 5.0	–	%
Output Leakage @ LOCAL = 0, $\overline{CS} = H$, $V_{out} = 15$ V, $V_{bat} = 6.0$ V	8	I_{out}	–	–	500	nA
Standby Current @ $I_{out} = 0$ mA, $\overline{CS} = H$, CLK = H, $V_{bat} = V_{BIAS} = 3.6$ V	10	I_{stdb}	–	3.0	–	μ A
Standby Current @ $I_{out} = 0$ mA, $\overline{CS} = H$, CLK = H, $V_{bat} = V_{BIAS} = 6.0$ V	10	I_{stdb}	–	–	10	μ A
Operating Current @ $V_{bat} = V_{BIAS} = 3.6$ V, $I_{ref} = 30$ μ A, CLK = H, $\overline{CS} = L$, LOCAL = Open	10	I_{ope}	–	600	–	μ A
Boost Internal Oscillator Clock @ $L1 = 22$ μ H, $V_{bat} = V_{BIAS} = 3.6$ V, $I_{out} = 20$ mA ($V_{out} = 14$ V)	–	F_{osc}	–	300	–	kHz

1. The tolerance refers to the 20 mA to 70 mA current range.

DIGITAL SECTION (–25°C to +85°C ambient temperature, unless otherwise noted.)

Rating	Pin	Symbol	Min	Typ	Max	Unit
High Level Input Voltage (Note 2)	3, 5	V_{IH}	$0.7 \cdot V_{bat}$	–	V_{bat}	V
Low Level Input Voltage (Note 2)		V_{IL}	–	–	$0.3 \cdot V_{bat}$	V
Input Capacitance		C_{in}	–	10	–	pF
High Level Input Voltage (Note 2)	6	V_{IH}	–	$0.6 \cdot V_{bat}$	–	V
Low Level Input Voltage (Note 2)		V_{IL}	–	$0.4 \cdot V_{bat}$	–	V
Input Capacitance		C_{in}	–	10	–	pF
LOCAL Pullup Resistor	6	R_{loc}	20	–	80	k Ω
LOCAL Leakage Current	9	I_{Loc}	–	–	100	nA
\overline{CS} Pullup Resistor	3	R_{cs}	20	–	80	k Ω
Minimum \overline{CS} Low Time	3	$T_{cssetup}$	250	–	–	ns
Clock Frequency	5	F_{CLK}	–	–	5.0	MHz
CLOCK tr and tf	5	t_{rCLK}, t_{fCLK}	10	–	–	ns
Internal Register Clear	–	t_{clear}	10	30	–	ns
Internal Power on Reset Width	–	t_{POR}	–	100	–	μ s

2. Digital inputs undershoot < – 0.30 V, Digital inputs overshoot < 0.30 V.

ANALOG SECTION (–25°C to +85°C ambient temperature, unless otherwise noted.)

Rating	Pin	Symbol	Min	Typ	Max	Unit
Output Voltage Range Reference @ 2.5 μ A < I_{ref} < 65 μ A (Note 3)	1	V_{ref}	1.20	1.24	1.28	V
Maximum Output Current Range Ratio	8	I_{out}	–	5595	–	–
Minimum Output Current Range Ratio	8	I_{out}	–	1119	–	–
Output Current Sense Resistor	10, 9	R_s	–	1.8	5.0	Ω
Output Voltage Range Reference @ 2.5 μ A < I_{pho} < 65 μ A	2	V_{pho}	1.20	1.24	1.28	V
Output Current Stabilization delay following a DC/DC startup	8	I_{outdly}	–	100	–	μ s
Internal NMOS Resistor @ $V_{bat} = 3.6$ V	8	QR_{DSON}	–	2.2	3.0	Ω
Internal Comparator Delay Time	–	T_{dcomp}	–	60	–	ns

3. The overall tolerance depends upon the accuracy of the external resistor. Using a 1%/low PPM metal film resistor is recommended to achieve $\pm 5\%$ output current tolerance.

NCP5008, NCP5009

TYPICAL OPERATING CHARACTERISTICS

Condition: Typical Application: L = 22 μ H, Cin = 10 μ F, Cout = 2.2 μ F, R1 = 30 k Ω

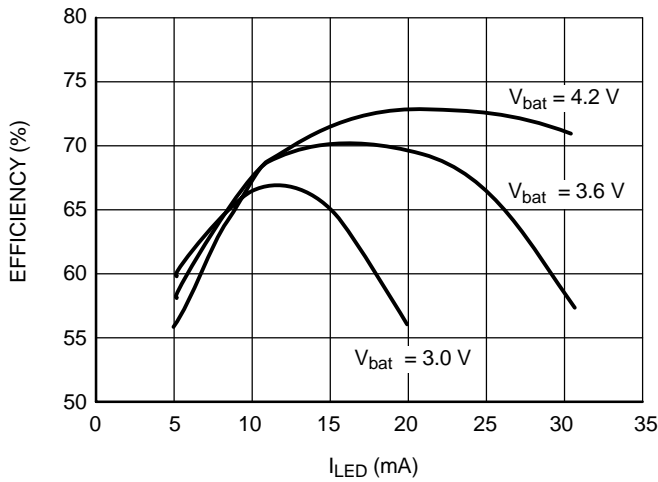

Figure 3. Efficiency vs. Load Current @ 4 LEDs
($V_{load} = 4 \cdot V_f \Rightarrow 14.2 \text{ V}$)

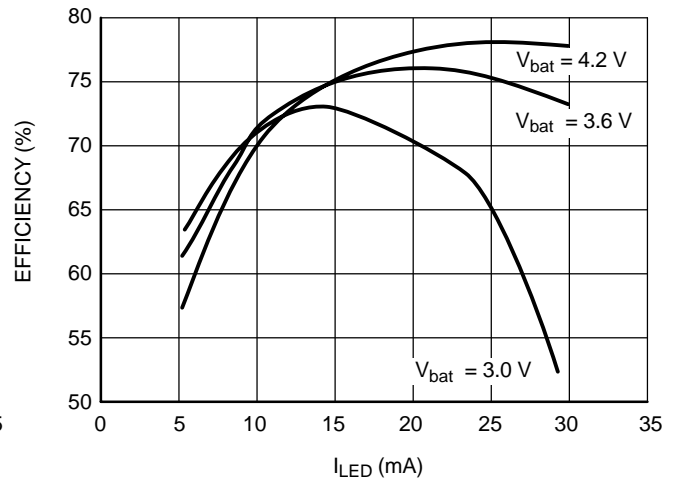

Figure 4. Efficiency vs. Load Current @ 3 LEDs
($V_{load} = 3 \cdot V_f \Rightarrow 10.5 \text{ V}$)

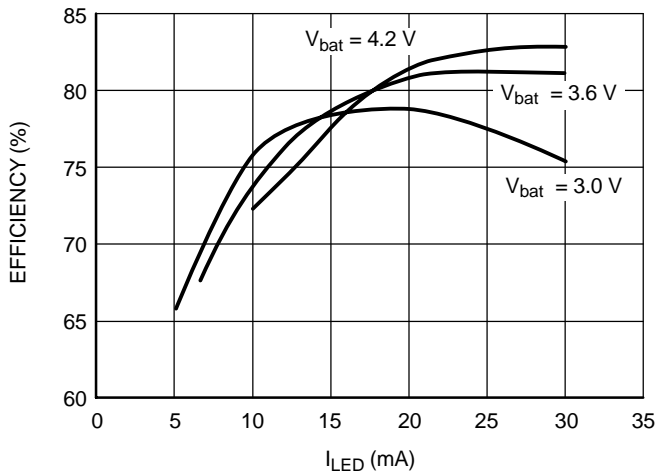

Figure 5. Efficiency vs. Load Current @ 2 LEDs
($V_{load} = 2 \cdot V_f \Rightarrow 7.1 \text{ V}$)

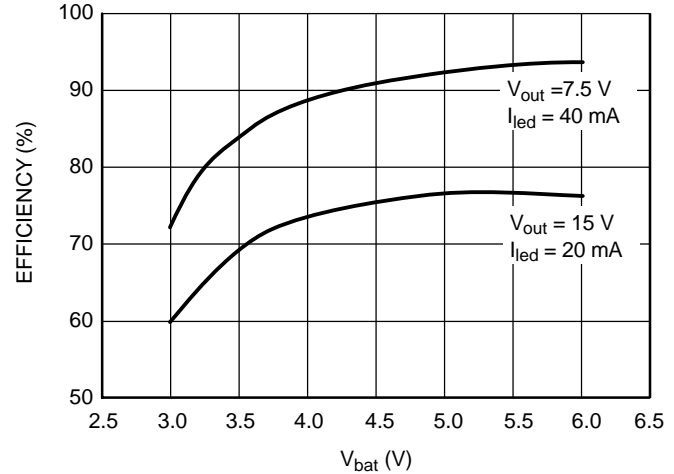

Figure 6. Efficiency vs. V_{bat} @
 $V_{out} = 15 \text{ V} / I_{led} = 20 \text{ mA}$ and
 $V_{out} = 7.5 \text{ V} / I_{led} = 40 \text{ mA}$

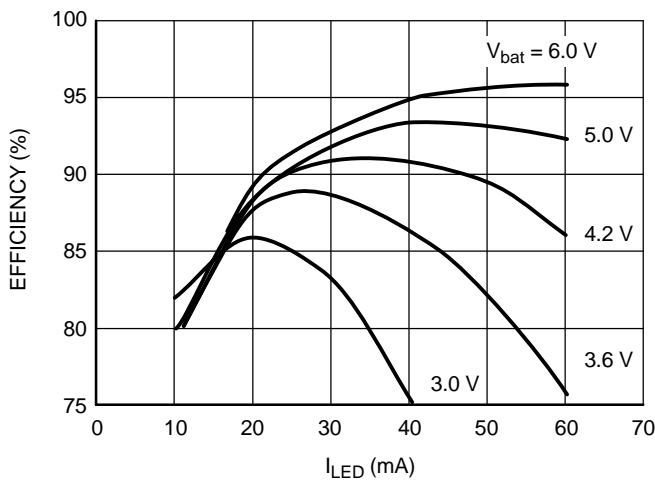

Figure 7. Efficiency vs. Load Current @ 4 LEDs
($V_{load} = 2 \text{ strings of } 2 \text{ LEDs in series} = 7.1 \text{ V}$)

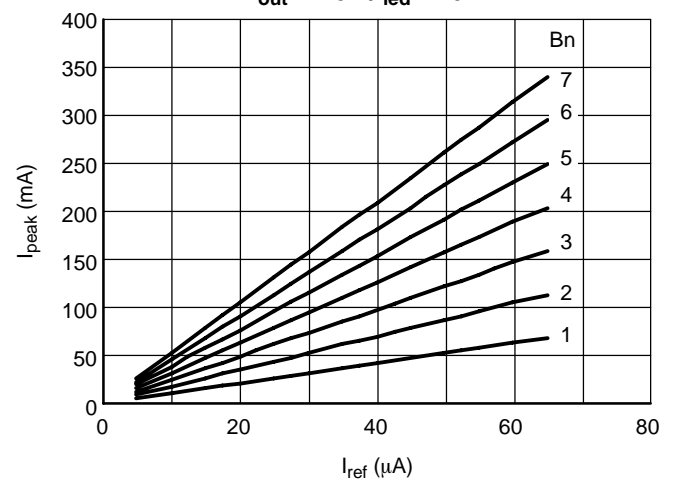
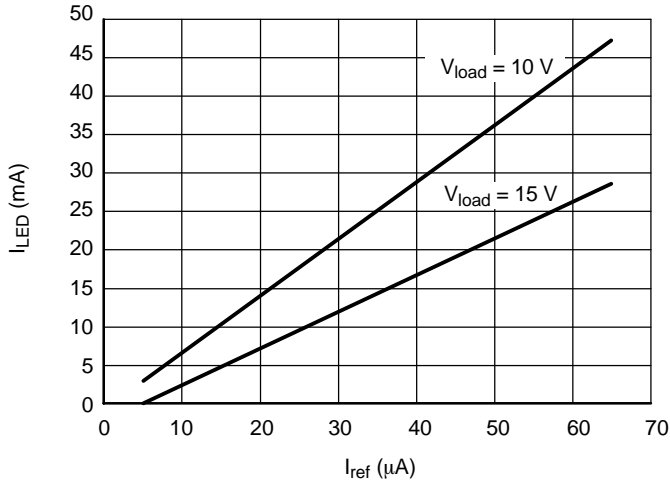

Figure 8. Inductor peak Current vs.
 I_{ref} @ $B_n = \{1, 2, 3, 4, 5, 6, 7\}$

NCP5008, NCP5009

TYPICAL OPERATING CHARACTERISTICS

Condition: Typical Application: L = 22 μ H, Cin = 10 μ F, Cout = 2.2 μ F, R1 = 30 k Ω



**Figure 9. Load Current (I_{LED}) vs. I_{ref}
@ $V_{bat} = 3.6$ V, $V_{load} = 15$ V and 10 V**

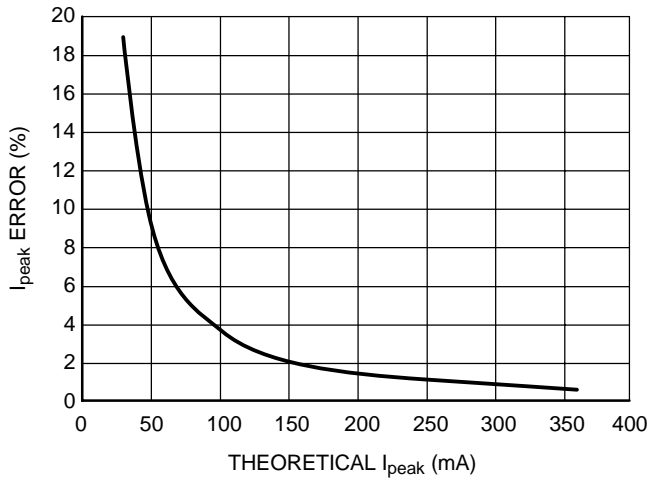

Figure 10. Inductor Peak Current Error vs. Theoretical Inductor Peak Current

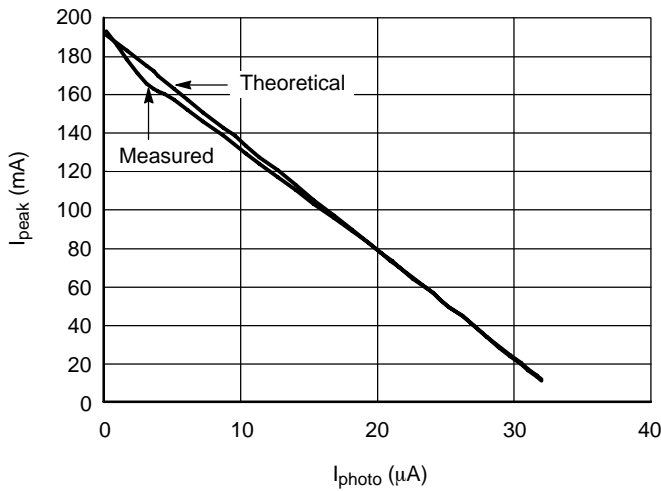

Figure 11. Inductor Peak Current vs. I_{photo} @ $I_{ref} = 34$ μ A

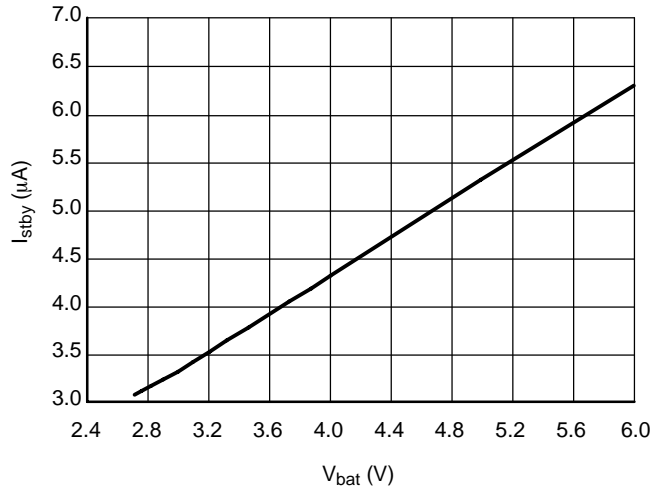
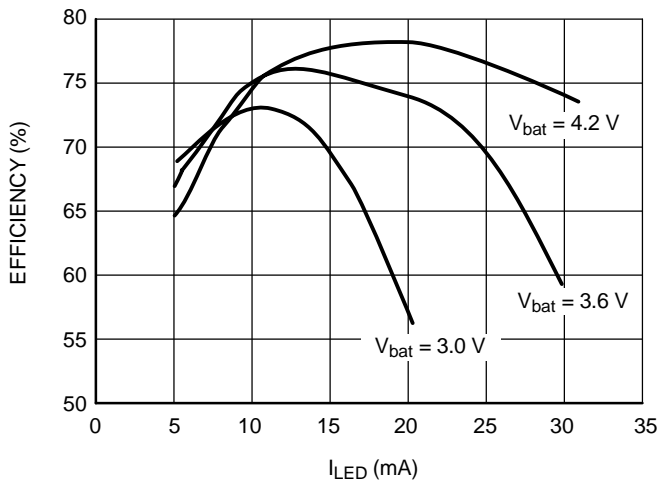
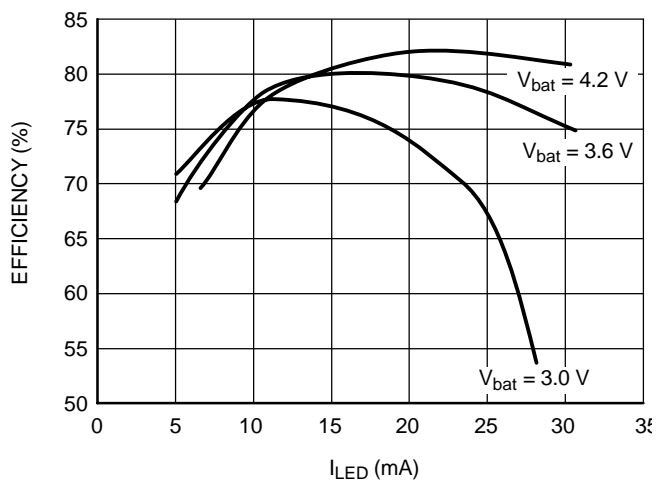

Figure 12. Stand by Current vs. V_{bat} @ $T = 20^{\circ}$ C



**Figure 13. Efficiency vs. Load Current @ 4 LEDs
($V_{load} = 4 \cdot V_f \Rightarrow 14.2$ V)**



**Figure 14. Efficiency vs. Load Current @ 3 LEDs
($V_{load} = 3 \cdot V_f \Rightarrow 10.5$ V)**

TYPICAL OPERATING CHARACTERISTICS

Condition: Typical Application: L = 22 μH, Cin = 10 μF, Cout = 2.2 μF, R1 = 30 kΩ

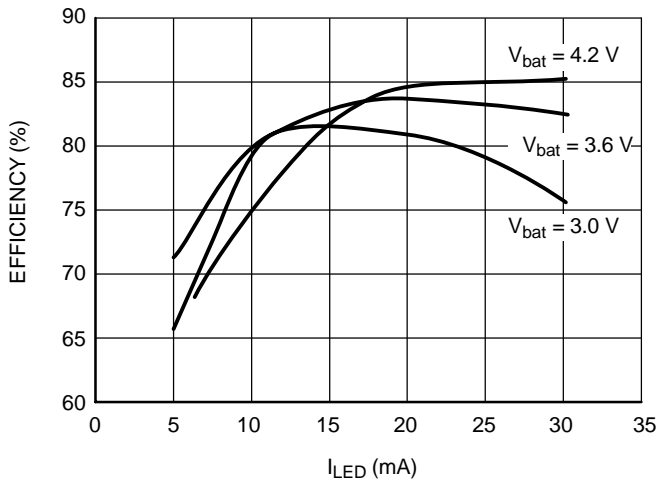

Figure 15. Efficiency vs Load Current @ 2 LEDs
($V_{load} = 2 * V_f \Rightarrow 7.1 \text{ V}$)

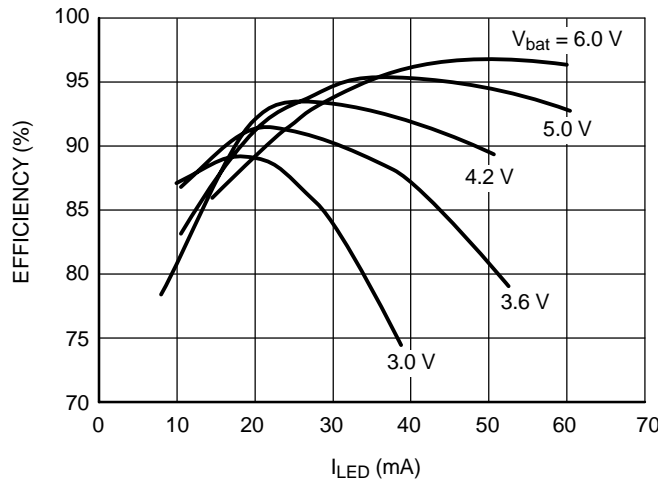

Figure 16. Efficiency vs Load Current @ 4 LEDs
($V_{load} = 2 \text{ strings of } 2 \text{ LEDs in series} = 7.1 \text{ V}$)

Operating Description

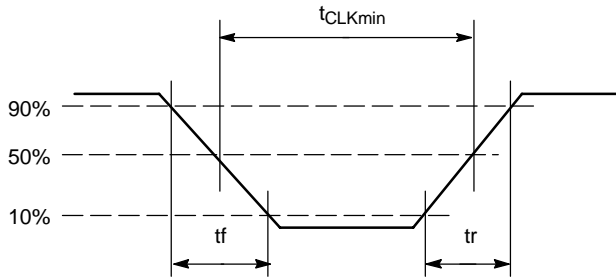

Figure 17. Digital Timing Definitions

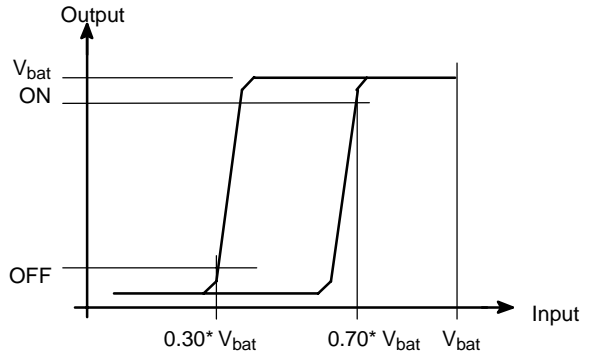

Figure 18. Typical Schmitt Trigger Characteristic

Input Schmitt Triggers

All the Logic Input pins have built-in Schmitt trigger circuits to prevent the NCP5008/NCP5009 against uncontrolled operation. The typical dynamic characteristics of the related pins are depicted in Figure 18.

The output signal is guaranteed to go High when the input voltage is above $0.70 * V_{bat}$, and will go Low when the input voltage is below $0.30 * V_{bat}$.

Local Mode

When the system operate in a Local Mode (Pin 6, /LOCAL=Low), the output current depends solely upon

the current drawn pin 1. The clock signal is irrelevant and the output current is derived by equation $I_{out} = I_{ref} * k$, the internal constant k being equal to 746.

ESD Protection

The NCP5008/NCP5009 includes silicon devices to protect the pins against the ESD spikes voltages. To cope with the different ESD voltages developed in the applications, the built-in structures have been designed to handle $\pm 2.0 \text{ kV}$ in Human Body Model (HBM) and $\pm 200 \text{ V}$ in Machine Model (MM) and on each pin.

Remote Control Programming Sequence

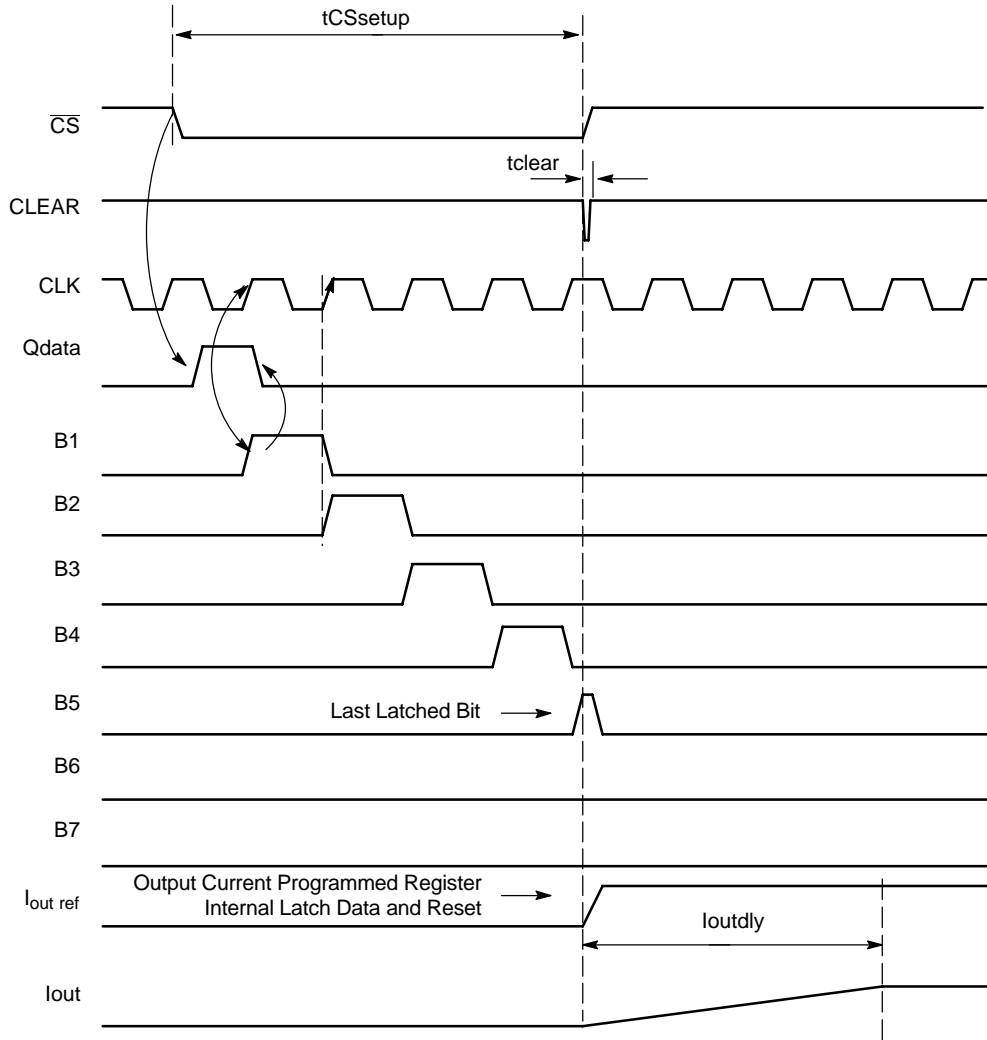

Figure 19. Programming Sequence

Upon \overline{CS} transition from High to Low, the internal sequence will take place:

- Qdata is internally set to high level.
- Upon positive going transition of the next CLK signal, the Qdata is shifted to the next Bn stage.
- Clear the Qdata flip-flop upon the positive going of the SetReg[B1] transient.

The sequence keeps going until $\overline{CS} = \text{High}$.

When the \overline{CS} line returns to a High state, the programming output current flip-flop is set according to the previous state of the shift register and SetReg B[1-7] is cleared afterward.

Depending upon the \overline{CS} width, for a given CLK period, the last SetReg bit will be latched and the output current

will be adjusted accordingly. If the number of CLK pulses is higher than 7, the Qdata is lost and the SetReg register bits B[1-7] are in the Low state, yielding a zero output current.

The internal shift register can be clear by sending more than 7 pulses to the CLK pin when the pin \overline{CS} is low. If the internal shift register is clear upon the \overline{CS} transition from Low to High, the device will be placed or maintained in the shut down mode.

When the register content is higher than zero, the DC/DC is activated and a 100 μs delay (typical) is necessary to stabilize the output current to the programmed value.

Set Up Output Current Range

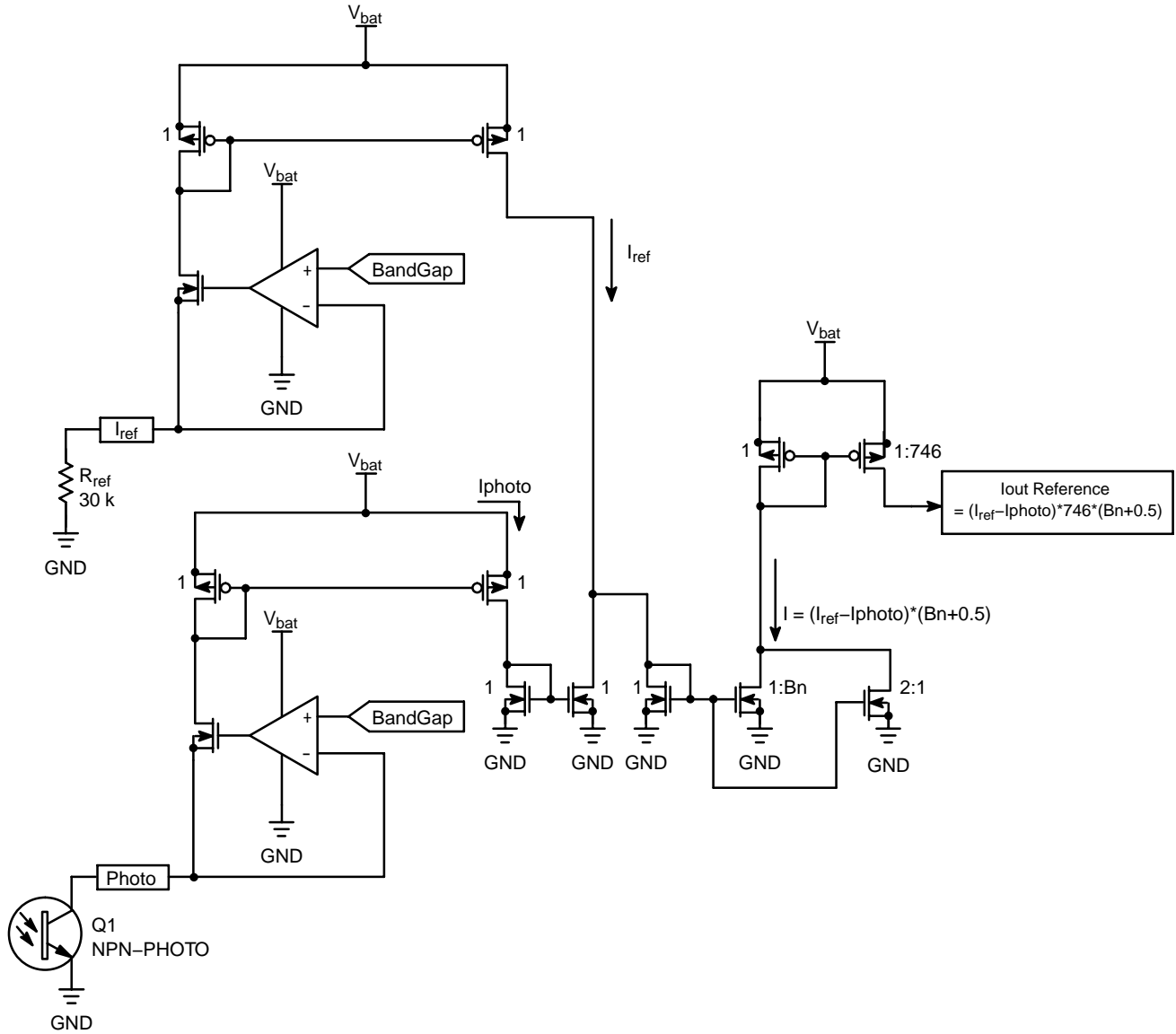

Figure 20. Functional Diagram

The current sunk to ground on PHOTO pin is subtracted from the current sunk to ground on I_{ref} pin. The result is multiplied by the programmed value (Bn) and then multiplied by the constant factor ratio (k = 746) in the current mirror.

The constant factor k is a ratio between the current on I_{out} sense and the I_{out} reference internally fixed.

The output current reference is:

$$I_{peak} = I_{valley} + (I_{ref} - I_{photo}) * Bn * k.$$

Where k = 746, Bn represents the bit of the internal shift register, range from 1 to 7, and I_{valley} = (I_{ref} - I_{photo}) * 0.5 * k.

We can write also I_{peak} = (I_{ref} - I_{photo}) * (Bn + 0.5) * k.

Please find below the formula to quickly calculate R1 resistor (resistor on I_{ref} pin):

$$I_{ref} = \frac{1.24}{R1}$$

DC/DC Converter Operation

The DC/DC converter operates with a boost structure depicted in Figure 21, the load being supplied by the pulsed current coming from the external inductor L1. The current

is monitored by the internal sense resistor R_{sense} to Set and Reset the flip-flop U3 and U6 according to the comparators U2 and U4 output state.

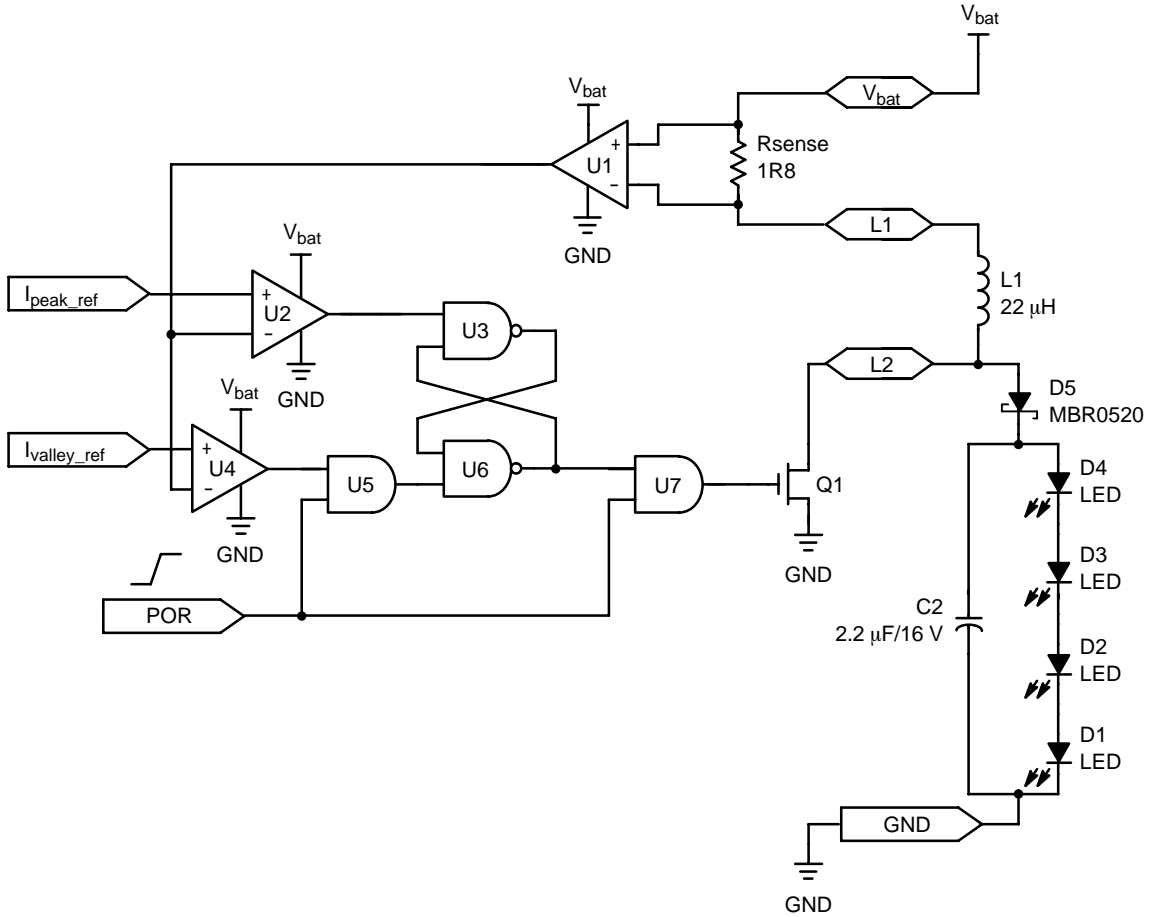

Figure 21. Basic DC/DC Boost Structure

Output Load Drive

In order to make profit of the built-in Boost capabilities, one shall operate the NCP5008/NCP5009 in the continuous output current mode. Such a mode is achieved by using an external reservoir capacitor (preferably a low ESR ceramic type) across the LED as depicted in Figures 22, 23, 24, 25, and 26.

Using an extra photo sensor is not mandatory and the related pin 2 can be either left open or connected to V_{bat} , but must not be grounded on the NCP5009 version only.

At this point, the designer must carefully analyze two parameters:

1. The output voltage must be limited to 15 V maximum. It's the designer responsibility to make sure that spike voltages beyond the

maximum rating will not exist across pin 8 and ground. Depending upon a specific application (V_{bat} voltage, PCB layout...), using an external voltage clamp could be necessary.

2. The peak current flowing into the LED diodes shall be within the maximum ratings specified for these devices.

The Schottky diode D5, associated with capacitor C2, provides a rectification and filtering function.

When a pulse-operating mode is acceptable:

- The LEDs brightness can be controlled in LOCAL mode with a PWM on \overline{CS} pin as depicted in Figure 24.
- Or the Schottky can be removed and replaced by at least one LED diode as depicted in Figure 23.

TYPICAL APPLICATION CIRCUIT

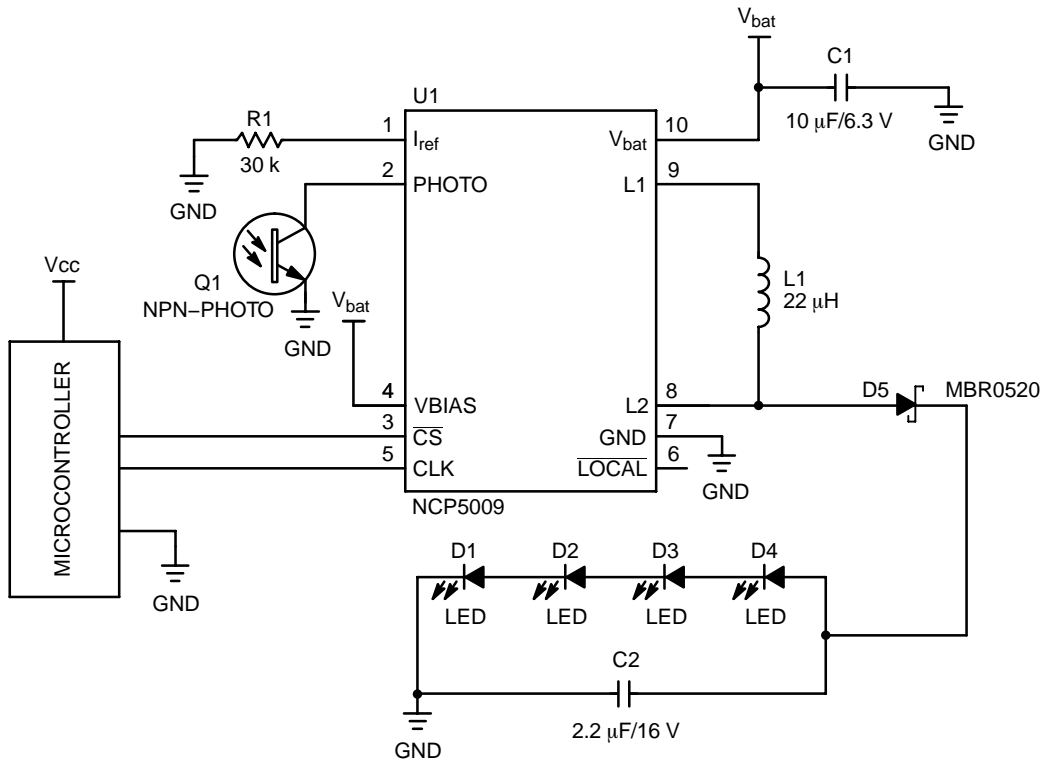

Figure 22. Basic DC Current Mode Operation in REMOTE Control

NCP5008, NCP5009

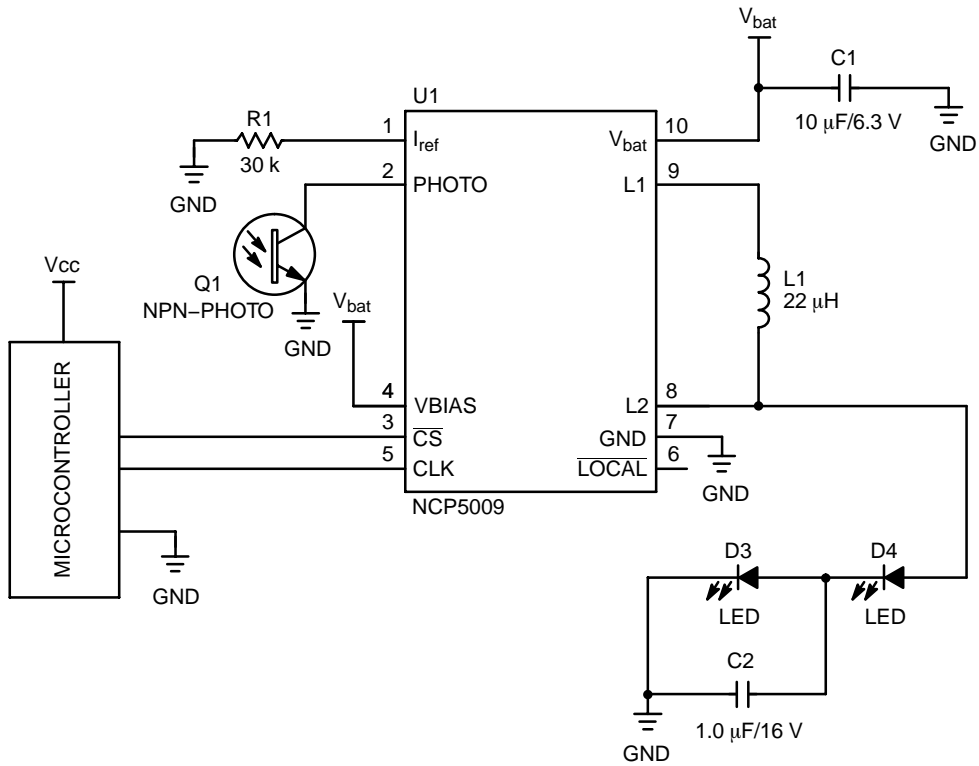

Figure 23. Typical Semi-Pulsed Mode of Operation in REMOTE Mode

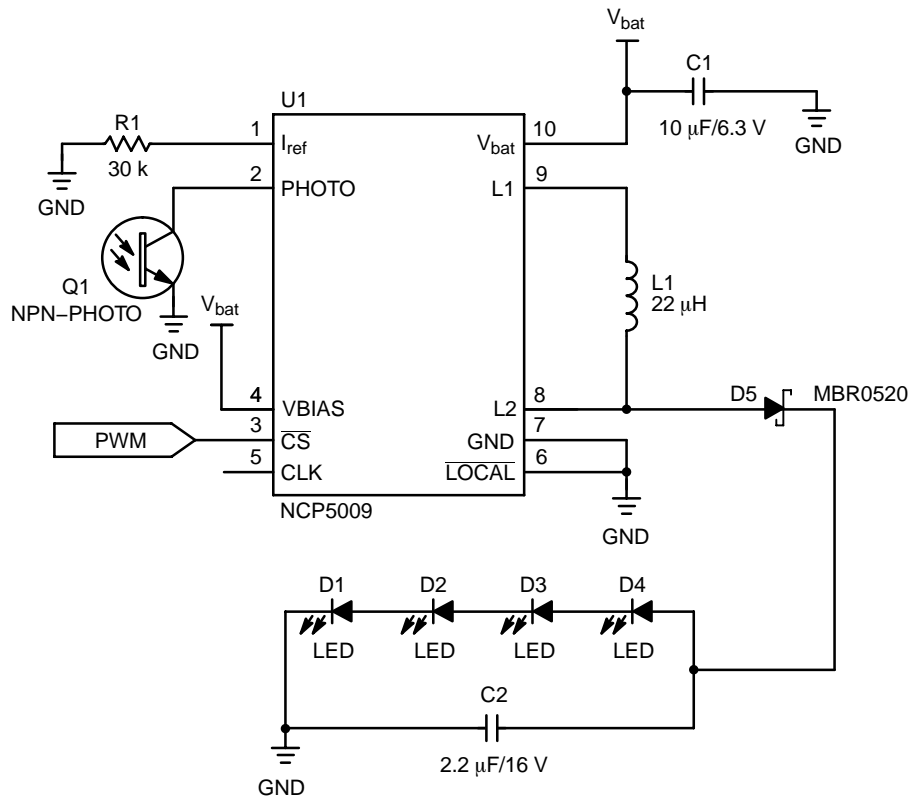

Figure 24. PWM Current Control Mode Operation in LOCAL Mode

NCP5008, NCP5009

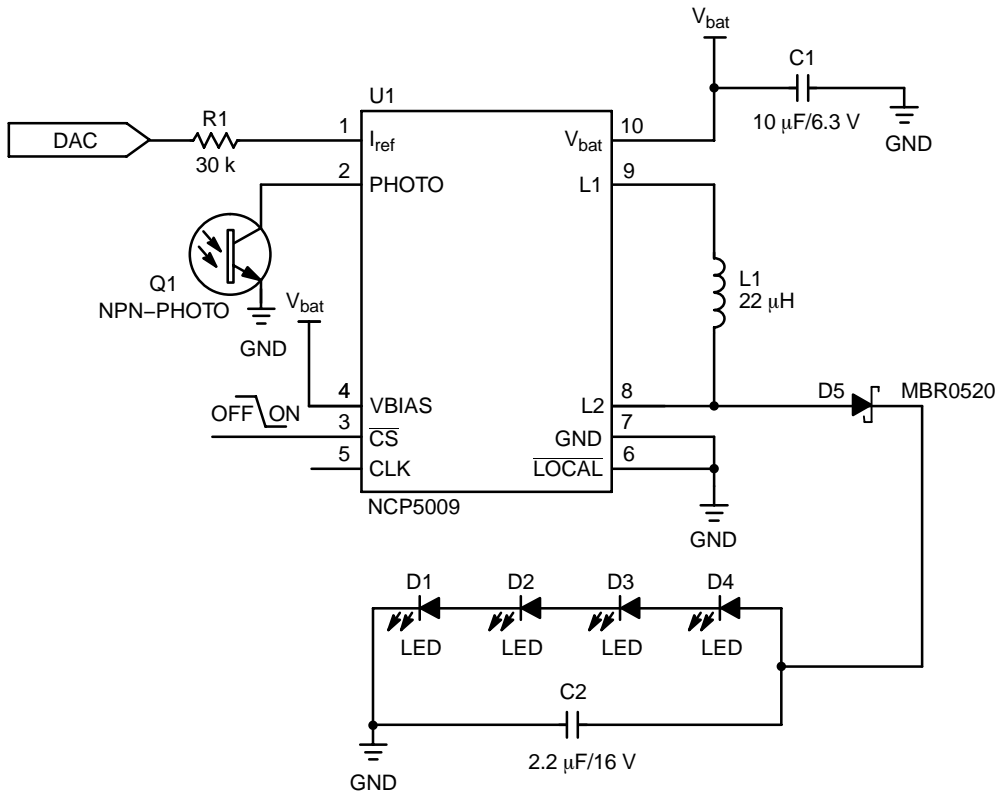

Figure 25. DAC Current Control Mode Operation in LOCAL Mode

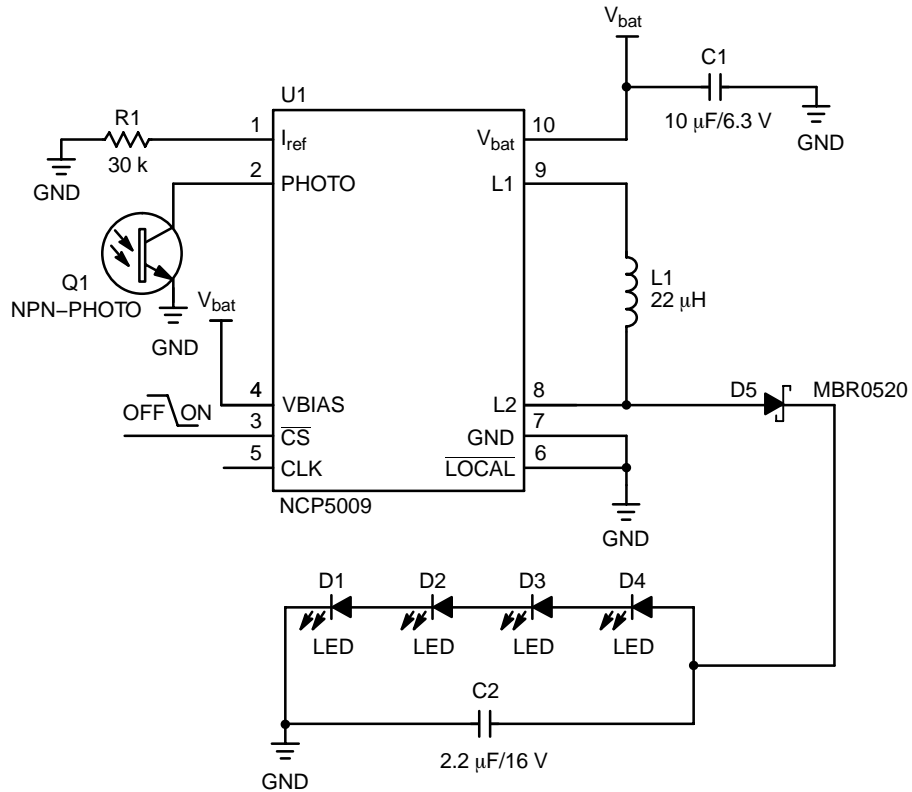

Figure 26. Basic DC Current Mode Operation in LOCAL Mode

NCP5008, NCP5009

TYPICAL LEDS LOAD MAPPING

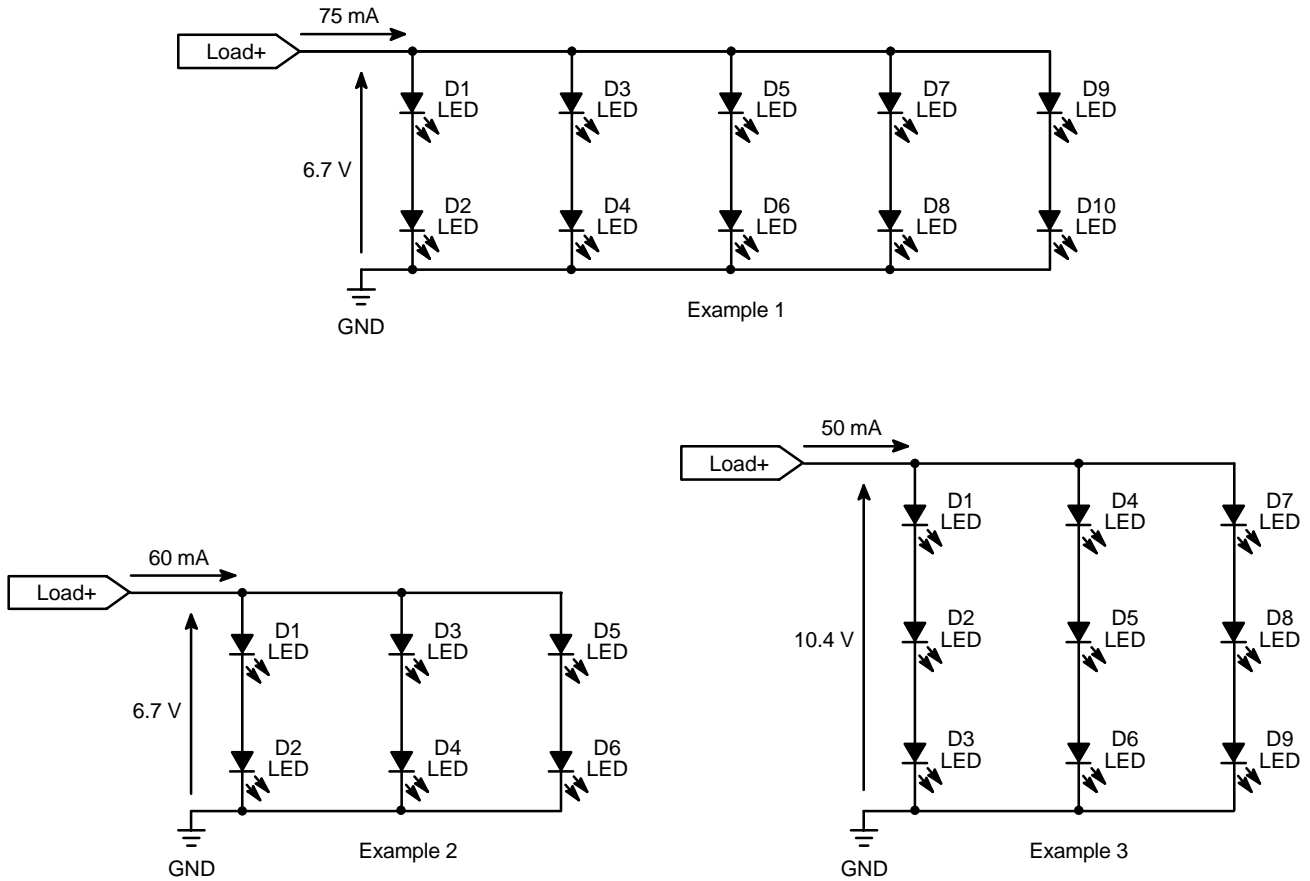

Figure 27. Three different examples of load can be driven by the NCP5009 or NCP5008

Condition: $V_{bat} = 3.6\text{ V}$, $L = 22\ \mu\text{H}$

MANUFACTURER REFERENCE

Design Ref	Value/Reference or Size	Manufacturer	Reference Number
D5	MBR0520/SOD-123	ON Semiconductor	MBR0520
L1	22 μH /1210	MURATA	LQH3C220K34
C1	10 μF /6.3 V/0805	MURATA	GRM40 X5R 106K 6.3
C2	2.2 μF /16 V/1206	MURATA	GRM42-6 X7R 225K 16
Q1	SFH320/PLCC2	Osram	SFH320
D1 to D4	White LED	Osram	LW5413-VBW-1

LAYOUT EXAMPLE

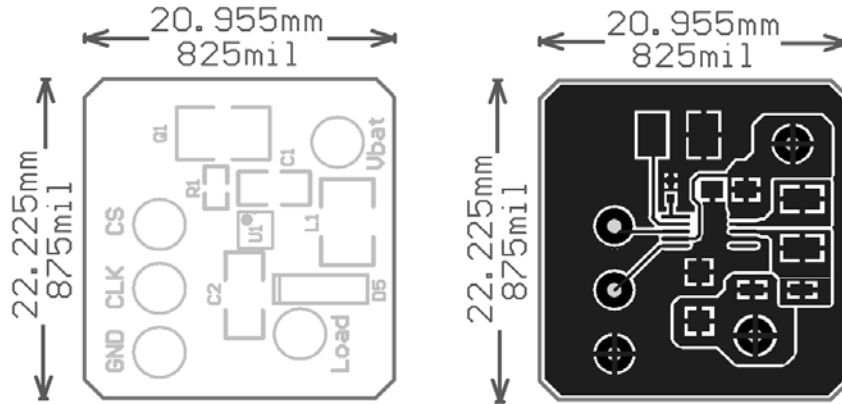

Figure 28. Typical Printed Circuit Layout (the Top Silk Screen and the Top Layer)

The Figure 28 represents the typical printed circuit layout based on the basic application Figure 1. This application has been routed on a single copper layer to save cost. A dual side PCB has better noise protection and can be the right choice for an industrial system. In order to avoid voltage spikes, care must be observed to group the capacitors, the inductor, the Schottky diode and the

integrated circuit in the same area. On the other hand, using large copper tracks to reduce the resistor connectivity is strongly recommended.

Obviously, the connectors GND, CLK, \overline{CS} , V_{bat} and Load are for engineering purpose only and not for final application.

NCP5008, NCP5009

PACKAGE DIMENSIONS

Micro10
CASE 846B-03
ISSUE D

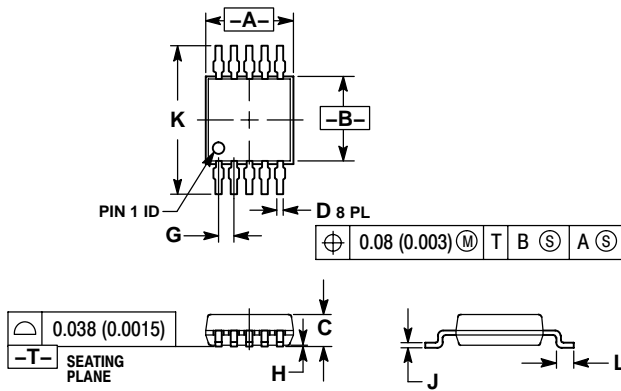

NOTES:

1. DIMENSIONING AND TOLERANCING PER ANSI Y14.5M, 1982.
2. CONTROLLING DIMENSION: MILLIMETER.
3. DIMENSION "A" DOES NOT INCLUDE MOLD FLASH, PROTRUSIONS OR GATE BURRS. MOLD FLASH, PROTRUSIONS OR GATE BURRS SHALL NOT EXCEED 0.15 (0.006) PER SIDE.
4. DIMENSION "B" DOES NOT INCLUDE INTERLEAD FLASH OR PROTRUSION. INTERLEAD FLASH OR PROTRUSION SHALL NOT EXCEED 0.25 (0.010) PER SIDE.
5. 846B-01 OBSOLETE. NEW STANDARD 846B-02

DIM	MILLIMETERS		INCHES	
	MIN	MAX	MIN	MAX
A	2.90	3.10	0.114	0.122
B	2.90	3.10	0.114	0.122
C	0.95	1.10	0.037	0.043
D	0.20	0.30	0.008	0.012
G	0.50 BSC		0.020 BSC	
H	0.05	0.15	0.002	0.006
J	0.10	0.21	0.004	0.008
K	4.75	5.05	0.187	0.199
L	0.40	0.70	0.016	0.028

SOLDERING FOOTPRINT*

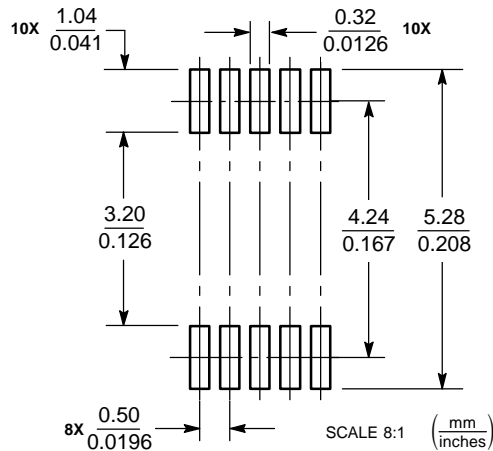

*For additional information on our Pb-Free strategy and soldering details, please download the ON Semiconductor Soldering and Mounting Techniques Reference Manual, SOLDERRM/D.

ON Semiconductor and are registered trademarks of Semiconductor Components Industries, LLC (SCILLC). SCILLC reserves the right to make changes without further notice to any products herein. SCILLC makes no warranty, representation or guarantee regarding the suitability of its products for any particular purpose, nor does SCILLC assume any liability arising out of the application or use of any product or circuit, and specifically disclaims any and all liability, including without limitation special, consequential or incidental damages. "Typical" parameters which may be provided in SCILLC data sheets and/or specifications can and do vary in different applications and actual performance may vary over time. All operating parameters, including "Typicals" must be validated for each customer application by customer's technical experts. SCILLC does not convey any license under its patent rights nor the rights of others. SCILLC products are not designed, intended, or authorized for use as components in systems intended for surgical implant into the body, or other applications intended to support or sustain life, or for any other application in which the failure of the SCILLC product could create a situation where personal injury or death may occur. Should Buyer purchase or use SCILLC products for any such unintended or unauthorized application, Buyer shall indemnify and hold SCILLC and its officers, employees, subsidiaries, affiliates, and distributors harmless against all claims, costs, damages, and expenses, and reasonable attorney fees arising out of, directly or indirectly, any claim of personal injury or death associated with such unintended or unauthorized use, even if such claim alleges that SCILLC was negligent regarding the design or manufacture of the part. SCILLC is an Equal Opportunity/Affirmative Action Employer. This literature is subject to all applicable copyright laws and is not for resale in any manner.

PUBLICATION ORDERING INFORMATION

LITERATURE FULFILLMENT:
Literature Distribution Center for ON Semiconductor
P.O. Box 61312, Phoenix, Arizona 85082-1312 USA
Phone: 480-829-7710 or 800-344-3860 Toll Free USA/Canada
Fax: 480-829-7709 or 800-344-3867 Toll Free USA/Canada
Email: orderlit@onsemi.com

N. American Technical Support: 800-282-9855 Toll Free
USA/Canada

Japan: ON Semiconductor, Japan Customer Focus Center
2-9-1 Kamimeguro, Meguro-ku, Tokyo, Japan 153-0051
Phone: 81-3-5773-3850

ON Semiconductor Website: <http://onsemi.com>

Order Literature: <http://www.onsemi.com/litorder>

For additional information, please contact your local Sales Representative.

Looking for pricing, stock, or lifecycle information?

Click below to explore more details on WIN SOURCE:

 [View NCP5008DMR2G on WIN SOURCE](#)

 [ON Semiconductor](#) Information

Optimize Your Supply Chain with WIN SOURCE Solutions

-  Global Sourcing Solution
-  Obsolete Management
-  Cost Control Management
-  Shortage Management
-  Alternative Solution
-  Excess Inventory Management