



**THE DATASHEET OF
NCP1800DM41R2**



NCP1800

Single-Cell Lithium Ion Battery Charge Controller

The NCP1800 is a constant current, constant voltage (CCCV) lithium ion battery charge controller. The external sense resistor sets the full charging current, and the termination current is 10% of the Full-Charge current (0.1 C). The voltage is regulated at $\pm 1\%$ during the final charge stage. There is virtually zero drain on the battery when the input power is removed.

Features

- Pb-Free Package is Available
- Integrated Voltage and Programmable Current Regulation
- Integrated Cell Conditioning for Deeply Discharged Cell
- Integrated End of Charge Detection
- Better than 1% Voltage Regulation
- Charger Status Output for LED or Host Processor Interface
- Charge Interrupt Input
- Safety Shutoff for Removal of Battery
- Adjustable Charge Current Limit
- Input Over and Undervoltage Lockout
- Micro8™ Package

Applications

- Cellular Phones, PDAs
- Handheld Equipment
- Battery Operated Portable Devices

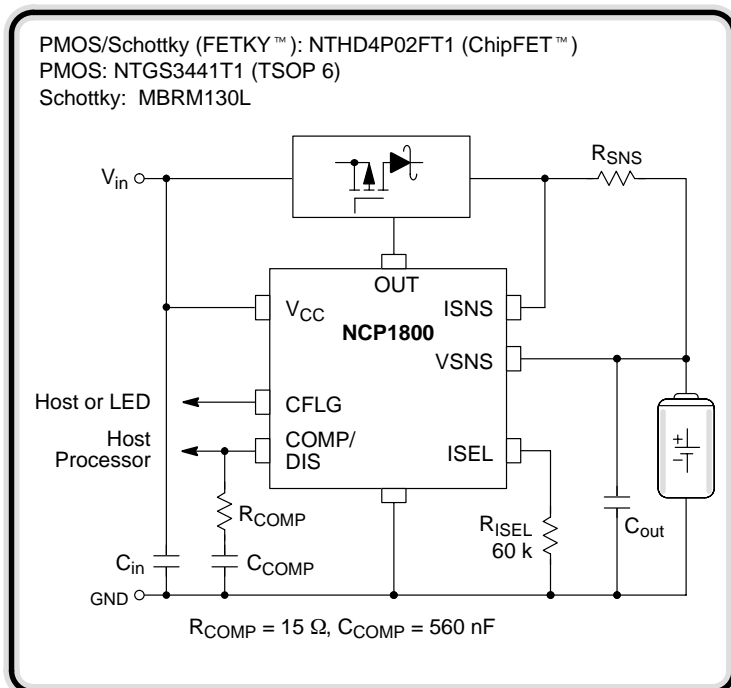
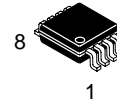

Figure 1. Typical Application



ON Semiconductor®

<http://onsemi.com>



Micro8™
 CASE 846A
 DM SUFFIX

PIN CONNECTIONS AND MARKING DIAGRAM

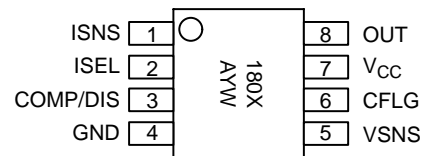

X = A for 41 Device
 B for 42 Device
 A = Assembly Location
 Y = Year
 W = Work Week

ORDERING INFORMATION

Device	Package	Shipping†
NCP1800DM41R2	Micro8	4000 Units/Reel
NCP1800DM42R2	Micro8	4000 Units/Reel
NCP1800DM41R2G	Micro8 (Pb-Free)	4000 Units/Reel

†For information on tape and reel specifications, including part orientation and tape sizes, please refer to our Tape and Reel Packaging Specifications Brochure, BRD8011/D.

NCP1800

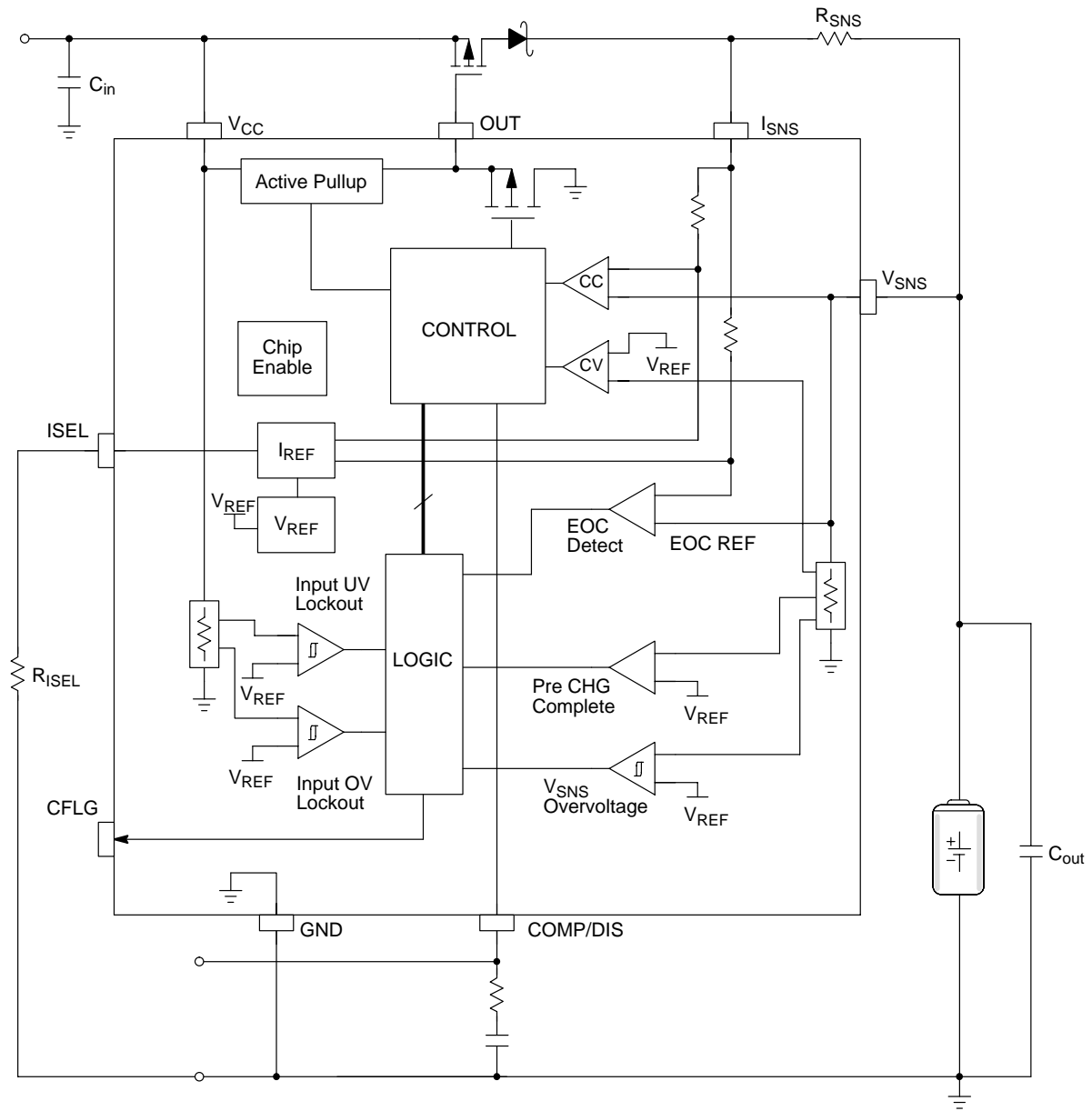

Figure 2. NCP1800 Internal Block Diagram

PIN FUNCTION DESCRIPTIONS

Pin	Symbol	Description
1	ISNS	This is one of the inputs to the current regulator and the end-of-charge comparator.
2	ISEL	A resistor from this pin to ground pin sets the full charging current regulation level.
3	COMP/DIS	This is a multifunctional pin that is used for compensation and can be used to interrupt charge with an open drain/collector output from a microcontroller. When this pin is pulled to ground, the charge current is interrupted.
4	GND	This is the ground pin of the IC.
5	VSNS	This is an input that is used to sense battery voltage and is the other input to the current regulator. It also serves as the input to the battery overvoltage comparator.
6	CFLG	An open drain output that indicates the battery charging status.
7	VCC	This is a multifunctional pin that powers the device and senses for over and undervoltage conditions.
8	OUT	This is a current source driver for the pass transistor.

NCP1800

MAXIMUM RATINGS

Rating	Symbol	Value	Unit
Supply Voltage	V_{CC}	16	V
Voltage Range for: VSNS Input ISNS Input COMP/DIS Input ISEL Input CFLG Output Out Output	–	–0.3 to 6.0 –0.3 to 6.0 –0.3 to 6.0 –0.3 to 6.0 –0.3 to 6.0 –0.3 to V_{CC}	V
OUT Sink Current	I_o	20	mA
Thermal Resistance, Junction–to–Air	$R_{\theta JA}$	240	°C/W
Operating Ambient Temperature	T_A	–20 to +85	°C
Operating Junction Temperature	T_J	–20 to +150	°C
Storage Temperature	T_{stg}	–55 to +150	°C

Maximum ratings are those values beyond which device damage can occur. Maximum ratings applied to the device are individual stress limit values (not normal operating conditions) and are not valid simultaneously. If these limits are exceeded, device functional operation is not implied, damage may occur and reliability may be affected.

ATTRIBUTES

Characteristic	Value
ESD Protection Human Body Model (HBM) per JEDEC standard JESD22–A114 Machine Model (MM) per JEDEC standard JESD22–A114	≤ 2 kV ≤ 200 V
Moisture Sensitivity, Indefinite Time Out of Drypack (Note 1)	Level 1
Transistor Count	1015
Latchup Current Maximum Rating per JEDEC standard JESD78	≤ 150 mA

1. For additional information, see Application Note AND8003/D.

ELECTRICAL CHARACTERISTICS ($T_A = 25^\circ\text{C}$ for typical values, $-20^\circ\text{C} < T_A < 85^\circ\text{C}$ for min/max values, unless otherwise noted.)

Characteristic	Symbol	Min	Typ	Max	Unit
Input Supply Voltage (Note 2)	V_{CC}	2.5	–	16	V
Input Supply Current	I_{CC}	–	140	250	μA
Regulated Output Voltage NCP1800DM41 NCP1800DM42	V_{REG}	4.059 4.158	4.1 4.2	4.141 4.242	V
Full–Charge Current Reference Voltage $V_{CC} = 6.0\text{ V}$, $3.0\text{ V} < V_{SNS} < 4.2\text{ V}$, $R_{ISEL} = 60\text{ K}\Omega$, $T_A = 25^\circ\text{C}$	V_{FCHG}	210	240	270	mV
Full–Charge Current Reference Voltage Temperature Coefficient $V_{CC} = 6.0\text{ V}$, $3.0\text{ V} < V_{SNS} < 4.2\text{ V}$, $R_{ISEL} = 60\text{ K}\Omega$	TCV_{FCHG}	–	–0.163	–	%/°C
Pre–Charge Current Reference Voltage $V_{CC} = 6.0\text{ V}$, $V_{SNS} < 3.0\text{ V}$, $R_{ISEL} = 60\text{ K}\Omega$, $T_A = 25^\circ\text{C}$	V_{PCHG}	13.2	24	34.8	mV
Pre– Charge Current Reference Voltage Temperature Coefficient $V_{CC} = 6.0\text{ V}$, $V_{SNS} < 3.0\text{ V}$, $R_{ISEL} = 60\text{ K}\Omega$	TCV_{PCHG}	–	–0.180	–	%/°C
Pre–Charge Threshold Voltage NCP1800DM41 NCP1800DM42	V_{PCTH}	2.78 2.85	2.93 3.0	3.08 3.15	V
V_{CC} Undervoltage Lockout Voltage	V_{UVLO}	3.43	3.56	3.69	V
Hysteresis of V_{CC} Undervoltage Lockout (V_{UVLO}), $T_A = 25^\circ\text{C}$	–	90	150	195	mV
Hysteresis of V_{CC} Undervoltage Lockout Voltage (V_{UVLO}) Temperature Coefficient	–	–	0.261	–	%/°C
End–of–Charge Voltage Reference $V_{CC} = 6.0\text{ V}$, $V_{SNS} > 4.2\text{ V}$, $R_{ISEL} = 60\text{ K}\Omega$, $T_A = 25^\circ\text{C}$	V_{EOC}	20	24	28	mV
End–of–Charge Voltage Reference Temperature Coefficient $V_{CC} = 6.0\text{ V}$, $V_{SNS} > 4.2\text{ V}$, $R_{ISEL} = 60\text{ K}\Omega$	TCV_{EOC}	–	–0.160	–	%/°C

2. See the “External Adaptor Power Supply Voltage Selection” section of the application note to determine the minimum voltage of the charger power supplies.

NCP1800

ELECTRICAL CHARACTERISTICS (continued)

($T_A = 25^\circ\text{C}$ for typical values, $-20^\circ\text{C} < T_A < 85^\circ\text{C}$ for min/max values, unless otherwise noted.)

Characteristic	Symbol	Min	Typ	Max	Unit
Charge Disable Threshold Voltage ($I_{\text{COMP}} = 100 \mu\text{A min.}$)	V_{CDIS}	–	–	0.08	V
V_{CC} Overvoltage Lockout	V_{OVLO}	6.95	7.20	7.45	V
Hysteresis of V_{CC} Overvoltage Lockout (V_{OVLO}), $T_A = 25^\circ\text{C}$	–	90	150	180	mV
Hysteresis of V_{CC} Overvoltage Lockout (V_{OVLO}) Temperature Coefficient	–	–	0.39	–	$\% / ^\circ\text{C}$
V_{SNS} Overvoltage Lockout	NCP1800DM41 NCP1800DM42 V_{SOVLO}	4.3 4.4	4.4 4.5	4.5 4.6	V
Hysteresis of V_{SNS} Overvoltage Lockout (V_{SOVLO}), $T_A = 25^\circ\text{C}$	–	40	70	100	mV
Hysteresis of V_{SNS} Overvoltage Lockout (V_{SOVLO}) Temperature Coefficient $T_A = 25^\circ\text{C}$	–	–	0.52	–	$\% / ^\circ\text{C}$
Full-Charge Current Range with $R_{\text{SNS}} = 0.4 \Omega$	I_{REG1}	600	–	1000	mA
Full-Charge Current Range with $R_{\text{SNS}} = 0.8 \Omega$	I_{REG2}	300	–	600	mA
Battery Drain Current ($V_{\text{SNS}} + I_{\text{SNS}}$) $V_{\text{CC}} = \text{Ground}$, $V_{\text{SNS}} = 4.2 \text{ V}$	I_{BDRN}	–	–	0.5	μA
CFLG Pin Output Low Voltage (CFLG = LOW, $I_{\text{CFLG}} = 5.0 \text{ mA}$)	V_{CFLGL}	–	–	0.35	V
CFLG Pin Leakage Current (CFLG = HIGH)	I_{CFLGH}	–	–	0.1	μA

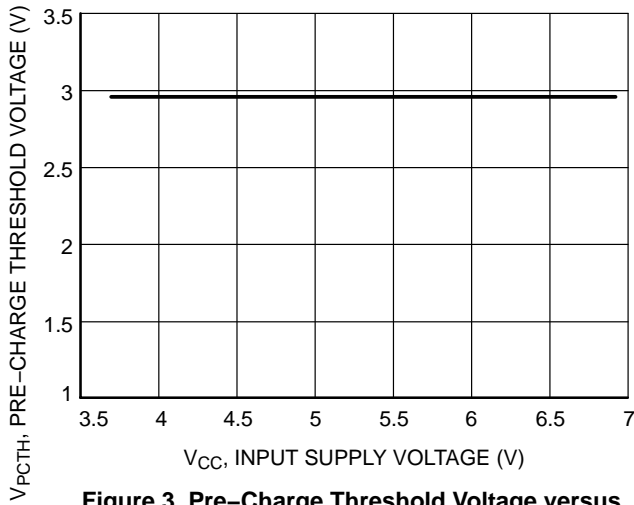

Figure 3. Pre-Charge Threshold Voltage versus Input Supply Voltage

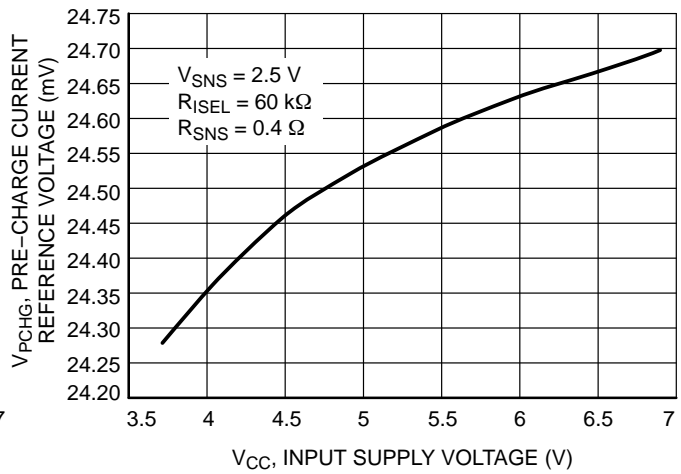

Figure 4. Pre-Charge Current Reference Voltage versus Input Supply Voltage

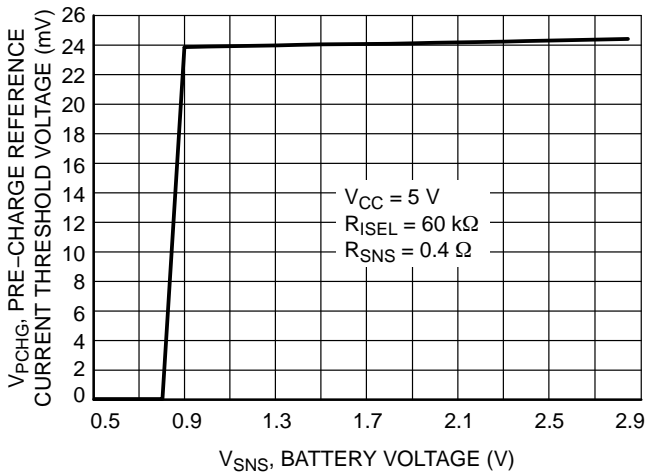

Figure 5. Pre-Charge Current Reference Voltage versus Battery Voltage

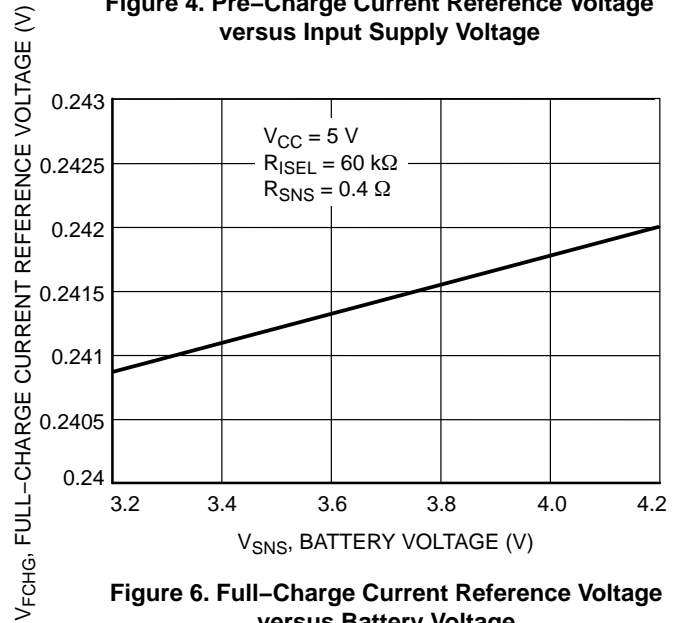

Figure 6. Full-Charge Current Reference Voltage versus Battery Voltage

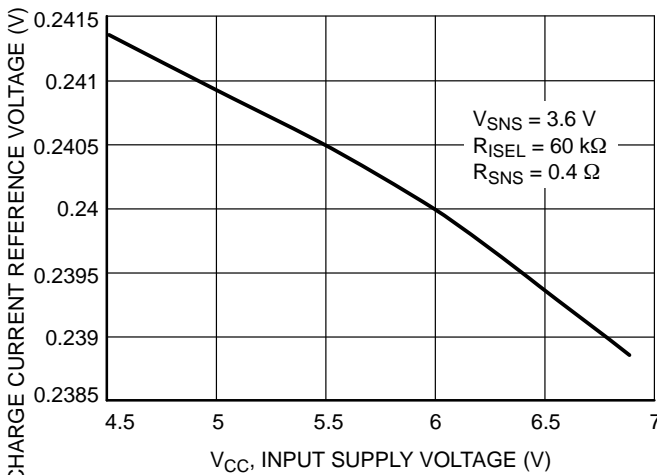

Figure 7. Full-Charge Current Reference Voltage versus Input Supply Voltage

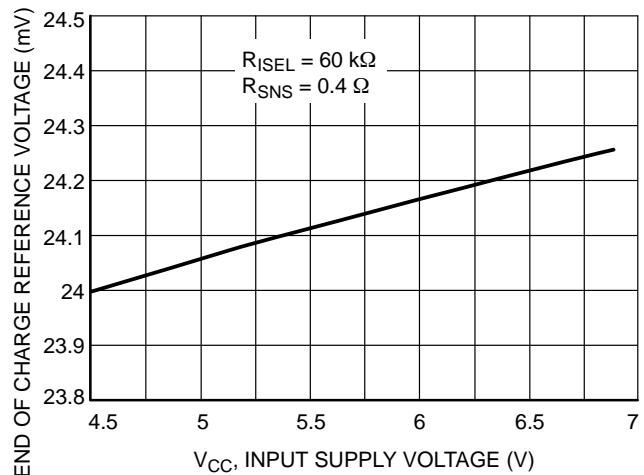

Figure 8. End of Charge Reference Voltage versus Input Supply Voltage

NCP1800

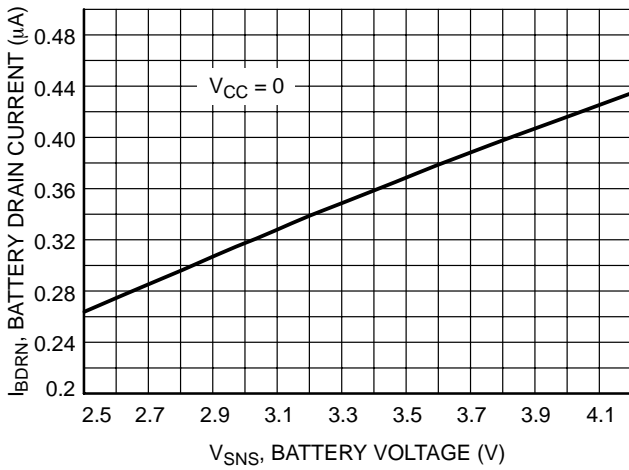

Figure 9. Battery Drain Current versus Battery Voltage

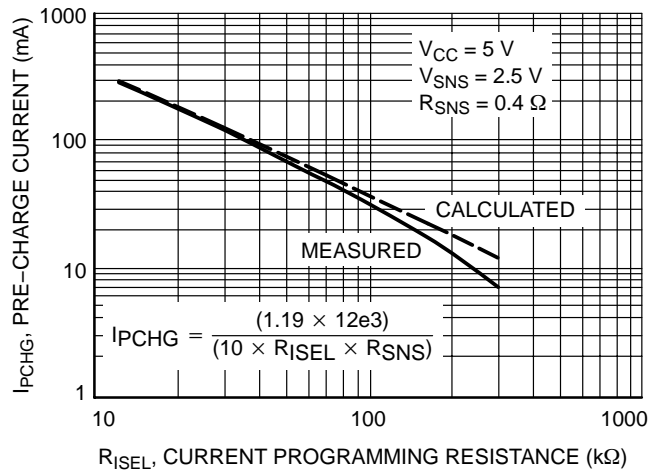

Figure 10. Pre-Charge Current versus Current Programming Resistor

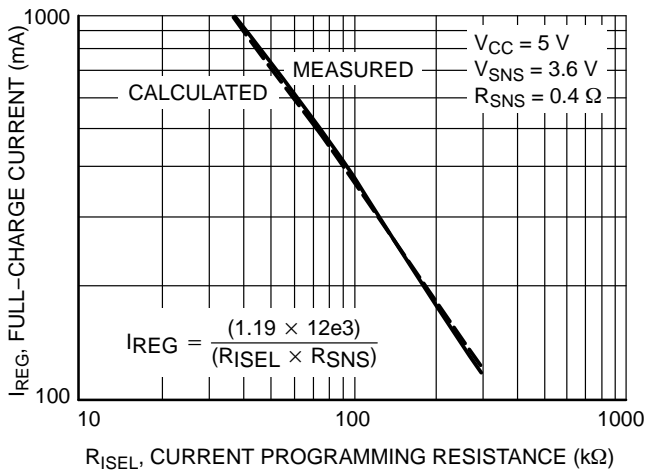

Figure 11. Full-Charge Current versus Current Programming Resistor

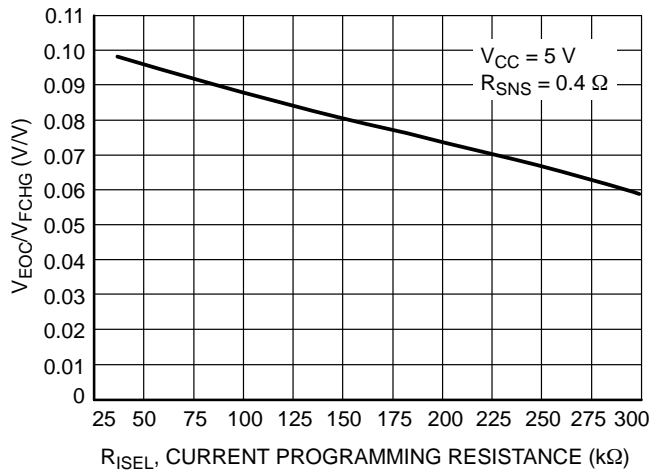

Figure 12. V_{EOC}/V_{FCHG} versus Current Programming Resistor

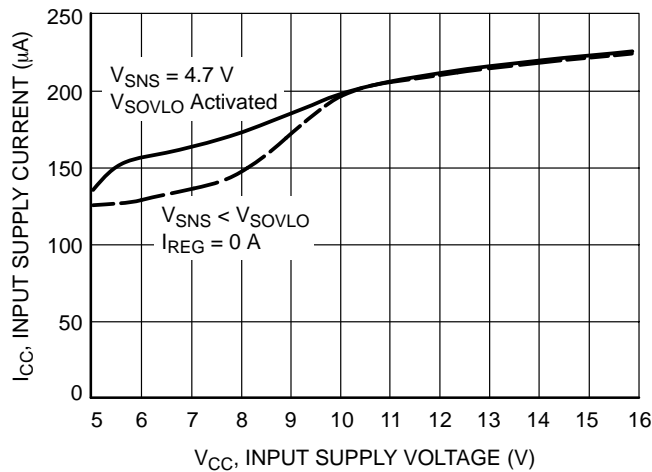

Figure 13. Input Supply Current versus Input Supply Voltage

NCP1800

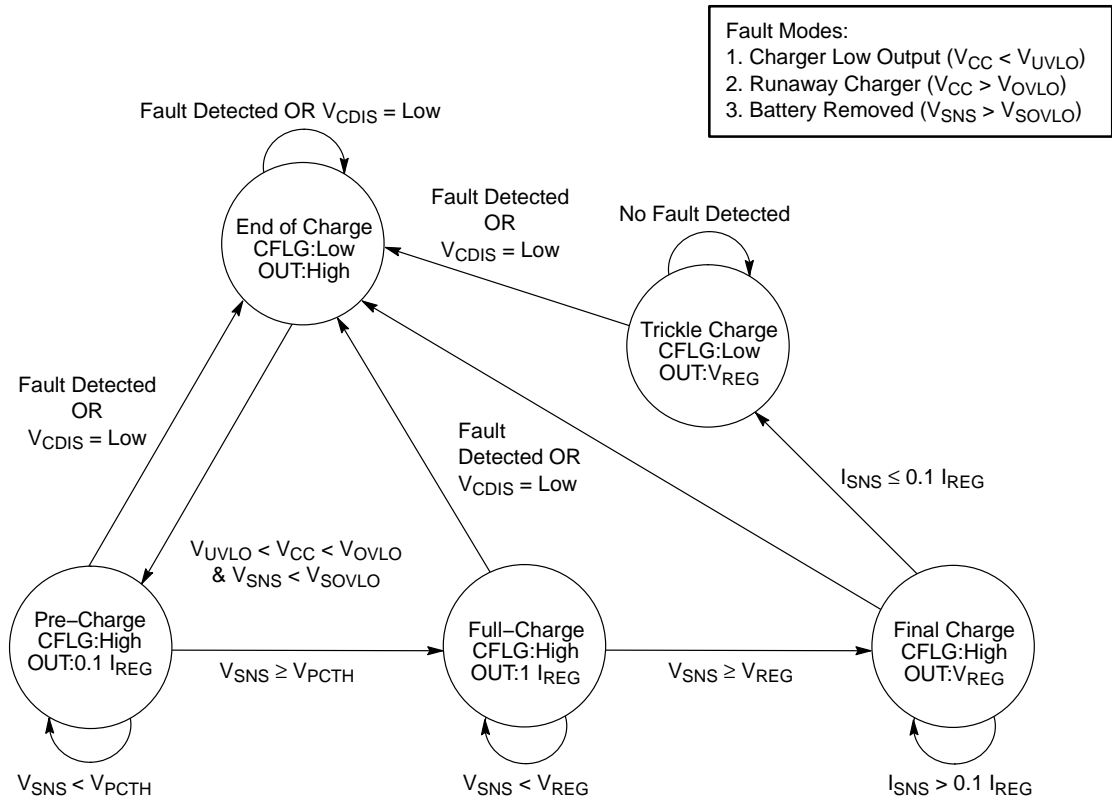

Figure 14. NCP1800 State Machine Diagram

NCP1800

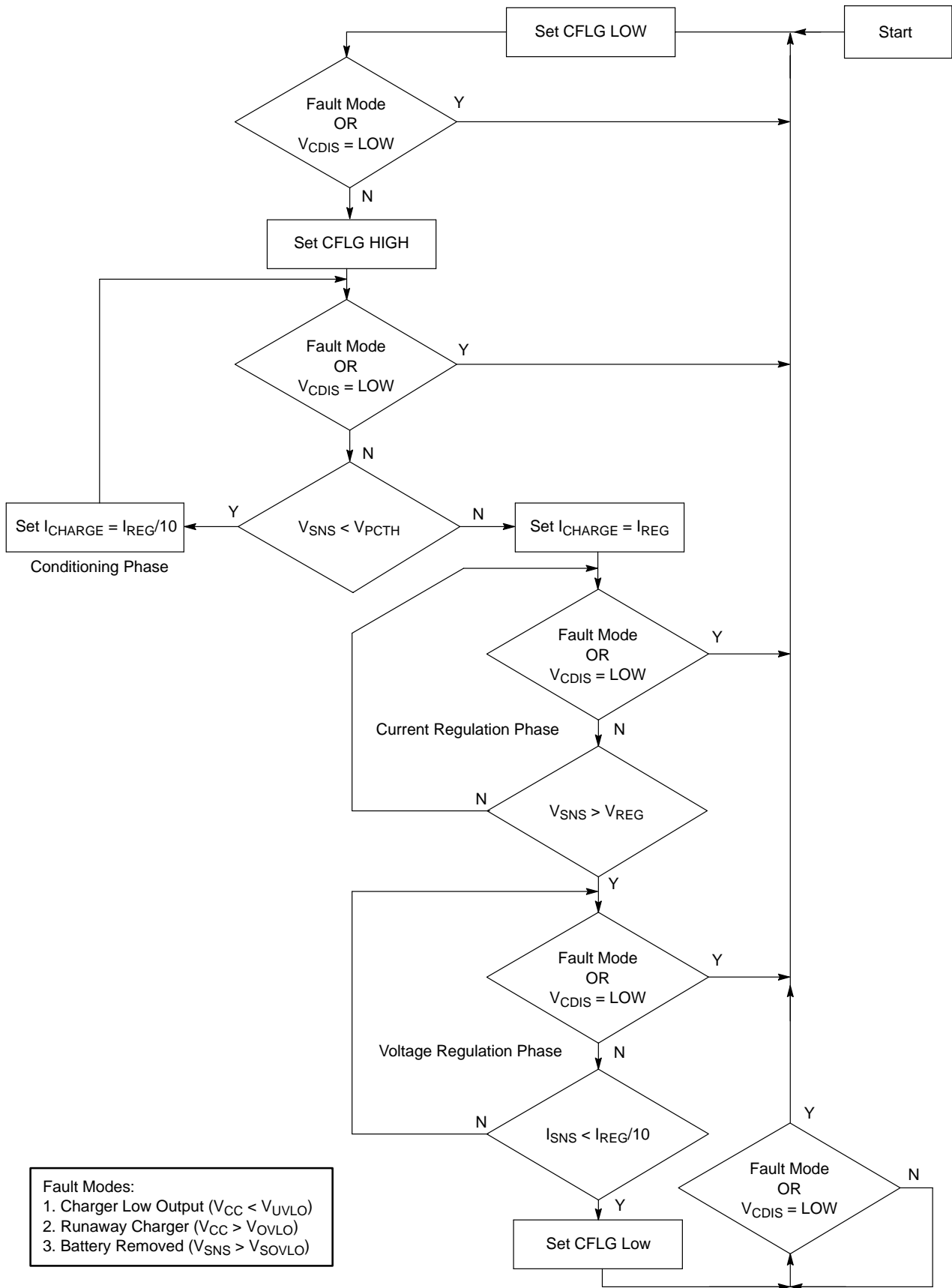

Figure 15. NCP1800 Charging Operational Flow Chart

NCP1800

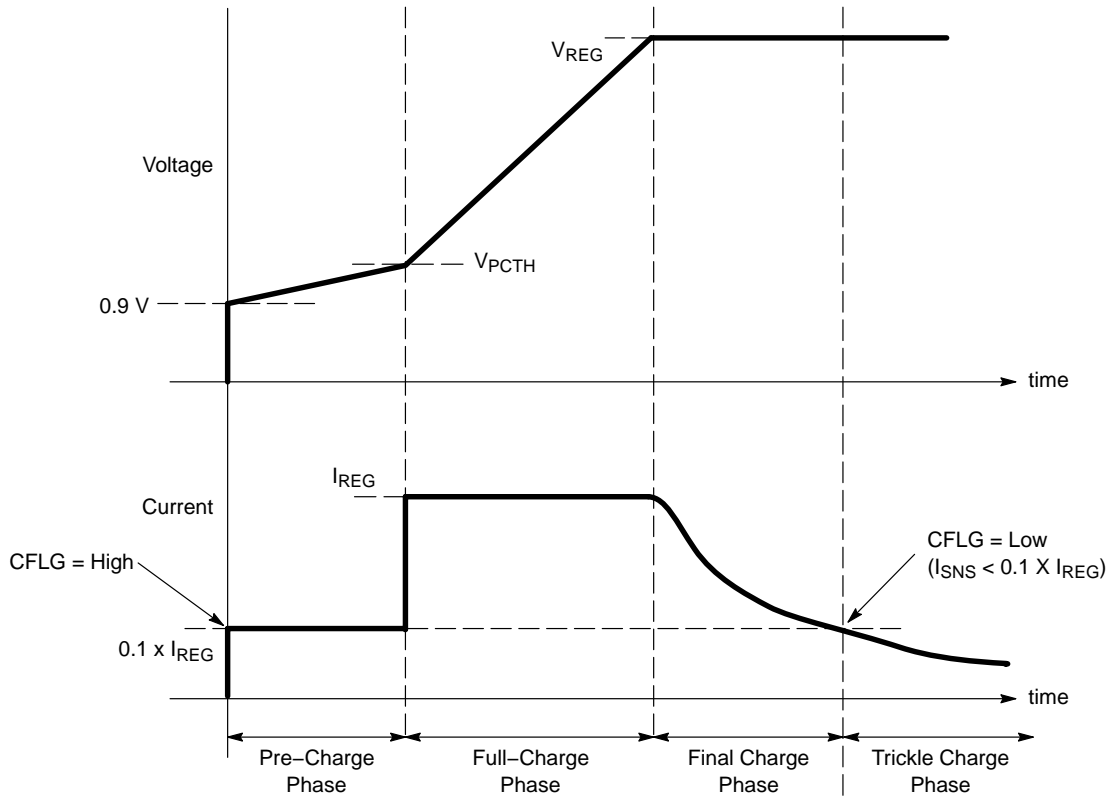

Figure 16. Typical Charging Algorithm

Charge Status

Conditions	CFLG Pin
Pre-Charge, Full-Charge and Final Charge	High-Z
End-of-Charge, Trickle Charge and Faults	Low

Operation Descriptions

The NCP1800 is a linear lithium ion (Li-ion) battery charge controller and provides the necessary control functions for charging Li-ion batteries precisely and safely. It features the constant current and constant voltage method (CCCV) of charging.

Conditioning and Pre-charge Phase

The NCP1800 initiates a charging cycle upon toggling the COMP/DIS to LOW or application of the valid external power source (i.e. $V_{UVLO} < V_{CC} < V_{OVLO}$) with the Li-ion battery present or when the Li-ion battery is inserted. Before a charge cycle can begin, the battery conditions are verified to be within safe limits. The battery will not be charged when its voltage is less than 0.9 V or higher than V_{SOVLO} .

Li-ion batteries can be easily damaged when fast charged from a completely discharged state. Also, a fully discharged Li-ion battery may indicate an abnormal battery condition. With the built-in safety features of the NCP1800, the Li-ion battery pre-charges (Pre-Charge Phase) at 10% of the full rated charging current (I_{REG}) when the battery voltage is lower than V_{PCTH} and the CFLG pin is HIGH. Typically, the battery voltage reaches V_{PCTH} in a few minutes and then the Full-Charge phase begins.

Full-Charge (Current Regulation) Phase

When the battery voltage reaches V_{PCTH} , the NCP1800 begins fast charging the battery with full rate charging current I_{REG} . The NCP1800 monitors the charging current at the I_{SNS} input pin by the voltage drop across a current sense resistor, R_{SNS} , and the charging current is maintained at I_{REG} by the pass transistor throughout the Full-Charge phase.

I_{REG} is determined by R_{SNS} and R_{ISEL} with the following formula:

$$I_{REG} = \frac{(1.19 \times 12 \text{ k})}{(R_{ISEL} \times R_{SNS})}$$

And with $R_{ISEL} = 60 \text{ k}$ and $R_{SNS} = 0.4 \Omega$, $I_{REG} = 0.6 \text{ A}$.

Since the external P-channel MOSFET is used to regulate the current to charge the battery and operates in linear mode as a linear regulator, power is dissipated in the pass transistor. Designing with a very well regulated external adaptor (e.g. $5.1 \text{ V} \pm 1\%$) can help to minimize the heat dissipation in the pass transistor. Care must be taken in heatsink designing in enclosed environments such as inside the battery operated portables or cellular phones.

The Full-Charge phase continues until the battery voltage reaches V_{REG} . The NCP1800 comes in two options with V_{REG} thresholds of 4.1 and 4.2 V.

Final Charge (Voltage Regulation) Phase

Once the battery voltage reaches V_{REG} , the pass transistor is controlled to regulate the voltage across the battery and the Final Charge phase (constant voltage mode) begins. Once the charger is in the Final Charge phase, the charger maintains a regulated voltage and the charging current will begin to decrease and is dependent on the state of the charge of the battery. As the battery approaches a fully charged condition, the charge current falls to a very low value.

Trickle Charge Phase

During the Final Charge phase, the charging current continues to decrease and the NCP1800 monitors the charging current through the current sense resistor R_{SNS} . When the charging current decreases to such a level that $I_{SNS} < 0.1 \times I_{REG}$, the CFLG pin is set to LOW and the Trickle Charge phase begins. The charger stays in the Trickle Charge phase until any fault modes are detected or the COMP/DIS pin is pulled low to start over the charging cycle.

NCP1800

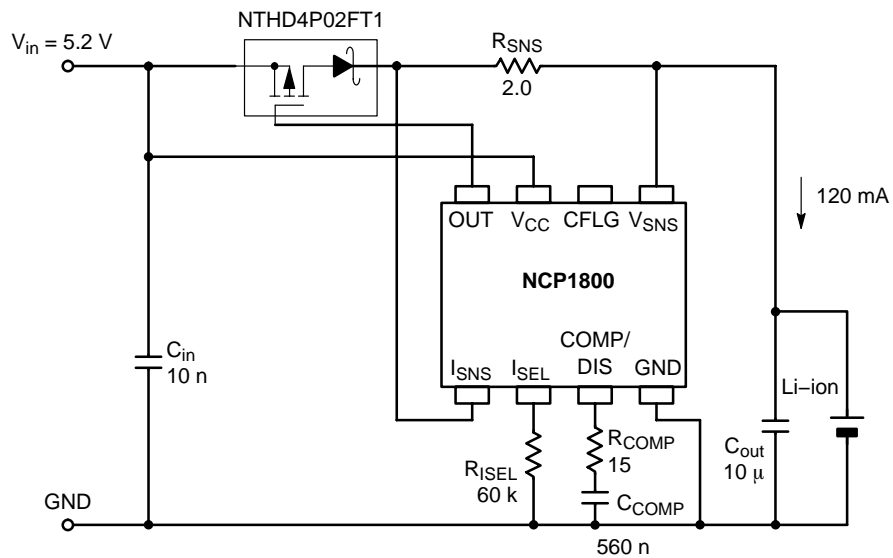

Figure 17. Typical Application Circuit for Lower Capacity Batteries (120 mAh shown here)

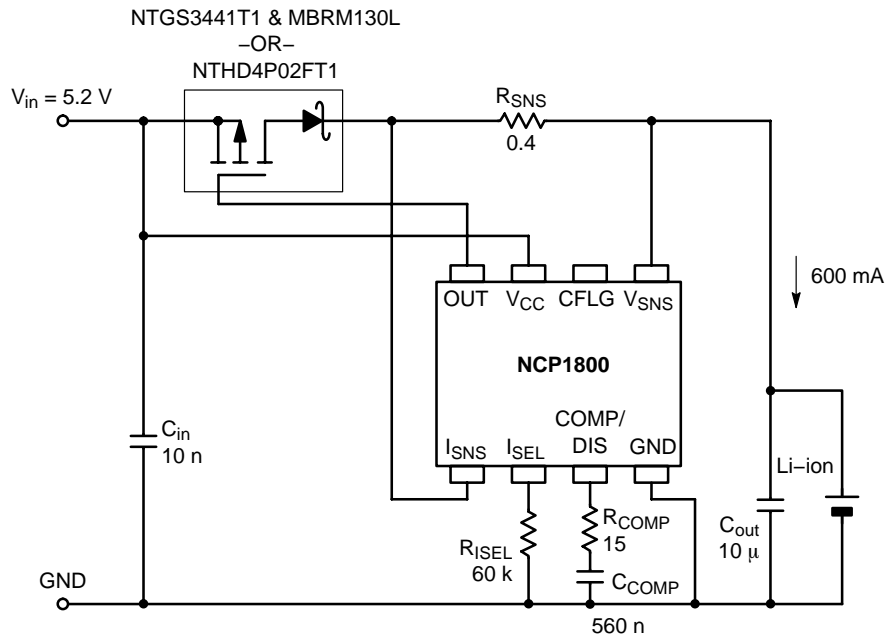

Figure 18. Typical Application Circuit for Higher Capacity Batteries (600 mAh shown here)

Selecting External Components

External Adaptor Power Supply Voltage Selection

Since the NCP1800 is using a linear, charging algorithm, the efficiency is lower. Adapter voltage selection must be done carefully in order to minimize the heat dissipation. In general, the power supply input voltage should be around 5.0 to 6.0 V. The minimum input voltage should be chosen to minimize the heat dissipation in the system. Excessively high input voltages can cause too much heat dissipation and will complicate the thermal design in applications like cellular phones. With the overvoltage protection feature of the NCP1800, input voltages higher than 7.0 V will activate the overvoltage protection circuit and disconnect the power supply input to the battery and other circuitry.

For the application shown in Figure 18 (assuming NTGS3441 and MBRM130L):

$$\begin{aligned}
 V_{IN(min)} &> \text{Li-ion regulated voltage,} \\
 &V_{REG} + (0.6 \text{ A})(R_{DS(ON)}) \\
 &+ V_F \text{ of Schottky Diode} + \text{voltage drop of } R_{SNS} \\
 &> 4.2 \text{ V} + (0.6 \text{ A})(100 \text{ m}\Omega) + 0.38 \text{ V} \\
 &+ (0.6 \text{ A})(0.4 \Omega) = 4.88 \text{ V} \approx 4.9 \text{ V}
 \end{aligned}$$

Therefore, for the application shown in Figure 17 (assuming NTHD4P01FT1):

$$\begin{aligned}
 V_{IN(min)} &> \text{Li-ion regulated voltage} \\
 &> 4.2 \text{ V} + (0.12 \text{ A})(130 \text{ m}\Omega) + 0.43 \\
 &+ (0.12 \text{ A})(2.0 \Omega) = 4.89 \text{ V} \approx 4.9 \text{ V}
 \end{aligned}$$

If the output voltage accuracy is 5%, then a typ. 5.2 V \pm 5% output voltage adaptor must be used.

And for a very good regulated adaptor of accuracy 1%, 5.0 V \pm 1% output voltage adaptor can then be used. It is obvious that if tighter tolerance adaptors are used, heat dissipation can be minimized by using lower nominal voltage adaptors.

Pass Element Selection

The type and size of the pass transistor is determined by input-output differential voltage, charging current, current sense resistor and the type of blocking diode used.

The selected pass element must satisfy the following criteria:

Drop across pass element =

$$V_{IN(min)} - \text{Li-ion regulated voltage} - V_F - I_{REG} \times R_{SNS}$$

With:

$$\begin{aligned}
 V_{IN(min)} &= 5.0 \text{ V} \\
 V_{REG} &= 4.2 \text{ V} \\
 I_{REG} &= 0.6 \text{ A} \\
 R_{SNS} &= 0.4 \Omega
 \end{aligned}$$

Dropout across pass element =

$$5.0 \text{ V} - 4.2 \text{ V} - 0.38 \text{ V} - (0.6 \text{ A})(0.4 \Omega) = 0.18 \text{ V}$$

Maximum $R_{DS(on)}$ should be less than $(0.18 \text{ V})/(0.6 \text{ A}) = 0.3 \Omega$ at 0.6 A.

$$\begin{aligned}
 V_{IN(min)} &= 5.0 \text{ V} \\
 V_{REG} &= 4.2 \text{ V} \\
 I_{REG} &= 0.12 \text{ A} \\
 R_{SNS} &= 2.0 \Omega
 \end{aligned}$$

Dropout across pass element = $5.0 \text{ V} - 4.2 \text{ V} - 0.43 \text{ V} - (0.12)(2.0 \Omega) = 0.13 \text{ V}$.

Therefore, maximum $R_{DS(on)}$ should be less than $(0.13 \text{ V})/(0.12 \text{ A}) = 1.08 \Omega$ at 0.12 A.

External Output Capacitor

Any good quality output filter can be used, independent of the capacitor's minimum ESR. However, a 10 μ F tantalum capacitor or electrolytic capacitor is recommended at the output to suppress fast ramping spikes at the V_{SNS} input and to ensure stability for 1.0 A at full range. The capacitor should be mounted with the shortest possible lead or track length to the V_{SNS} and GND pins.

Current Sense Resistor

The charging current can be set by the value of the current sense resistor as in the previous formula. Proper de-rating is advised when selecting the power dissipation rating of the resistor. If necessary, R_{ISEL} can also be changed for proper selection of the R_{SNS} values. Take note of the recommended full-charge current ranges specified in the electrical characteristics section. Also notice the effect of R_{ISEL} on the accuracy of pre-charge current and end-of-charge detection as noted in Figures 10 and 12, respectively.

NCP1800

PACKAGE DIMENSIONS

Micro8
DM SUFFIX
CASE 846A-02
ISSUE F

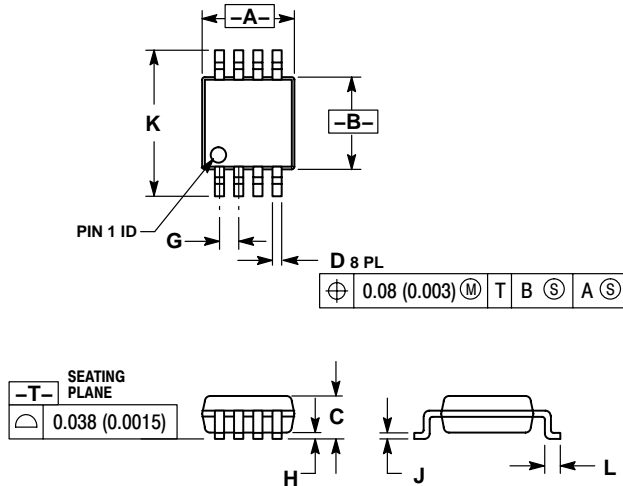

- NOTES:
1. DIMENSIONING AND TOLERANCING PER ANSI Y14.5M, 1982.
 2. CONTROLLING DIMENSION: MILLIMETER.
 3. DIMENSION A DOES NOT INCLUDE MOLD FLASH, PROTRUSIONS OR GATE BURRS. MOLD FLASH, PROTRUSIONS OR GATE BURRS SHALL NOT EXCEED 0.15 (0.006) PER SIDE.
 4. DIMENSION B DOES NOT INCLUDE INTERLEAD FLASH OR PROTRUSION. INTERLEAD FLASH OR PROTRUSION SHALL NOT EXCEED 0.25 (0.010) PER SIDE.
 5. 846A-01 OBSOLETE, NEW STANDARD 846A-02.

DIM	MILLIMETERS		INCHES	
	MIN	MAX	MIN	MAX
A	2.90	3.10	0.114	0.122
B	2.90	3.10	0.114	0.122
C	---	1.10	---	0.043
D	0.25	0.40	0.010	0.016
G	0.65 BSC		0.026 BSC	
H	0.05	0.15	0.002	0.006
J	0.13	0.23	0.005	0.009
K	4.75	5.05	0.187	0.199
L	0.40	0.70	0.016	0.028

SOLDERING FOOTPRINT*

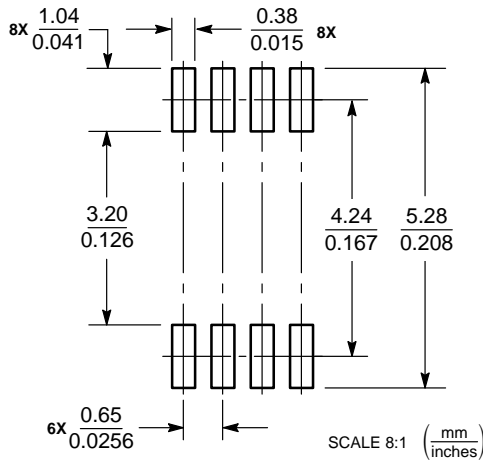

*For additional information on our Pb-Free strategy and soldering details, please download the ON Semiconductor Soldering and Mounting Techniques Reference Manual, SOLDERRM/D.

NCP1800

ChipFET is a trademark of Vishay Siliconix.
FETKY and Micro8 are trademarks of International Rectifier Corporation.

ON Semiconductor and  are registered trademarks of Semiconductor Components Industries, LLC (SCILLC). SCILLC reserves the right to make changes without further notice to any products herein. SCILLC makes no warranty, representation or guarantee regarding the suitability of its products for any particular purpose, nor does SCILLC assume any liability arising out of the application or use of any product or circuit, and specifically disclaims any and all liability, including without limitation special, consequential or incidental damages. "Typical" parameters which may be provided in SCILLC data sheets and/or specifications can and do vary in different applications and actual performance may vary over time. All operating parameters, including "Typicals" must be validated for each customer application by customer's technical experts. SCILLC does not convey any license under its patent rights nor the rights of others. SCILLC products are not designed, intended, or authorized for use as components in systems intended for surgical implant into the body, or other applications intended to support or sustain life, or for any other application in which the failure of the SCILLC product could create a situation where personal injury or death may occur. Should Buyer purchase or use SCILLC products for any such unintended or unauthorized application, Buyer shall indemnify and hold SCILLC and its officers, employees, subsidiaries, affiliates, and distributors harmless against all claims, costs, damages, and expenses, and reasonable attorney fees arising out of, directly or indirectly, any claim of personal injury or death associated with such unintended or unauthorized use, even if such claim alleges that SCILLC was negligent regarding the design or manufacture of the part. SCILLC is an Equal Opportunity/Affirmative Action Employer. This literature is subject to all applicable copyright laws and is not for resale in any manner.

PUBLICATION ORDERING INFORMATION

LITERATURE FULFILLMENT:

Literature Distribution Center for ON Semiconductor
P.O. Box 61312, Phoenix, Arizona 85082-1312 USA
Phone: 480-829-7710 or 800-344-3860 Toll Free USA/Canada
Fax: 480-829-7709 or 800-344-3867 Toll Free USA/Canada
Email: orderlit@onsemi.com

N. American Technical Support: 800-282-9855 Toll Free
USA/Canada

Japan: ON Semiconductor, Japan Customer Focus Center
2-9-1 Kamimeguro, Meguro-ku, Tokyo, Japan 153-0051
Phone: 81-3-5773-3850

ON Semiconductor Website: <http://onsemi.com>

Order Literature: <http://www.onsemi.com/litorder>

For additional information, please contact your
local Sales Representative.

Looking for pricing, stock, or lifecycle information?

Click below to explore more details on WIN SOURCE:

- ⊖ [View NCP1800DM41R2 on WIN SOURCE](#)
- ⊖ [ON Semiconductor Information](#)

Optimize Your Supply Chain with WIN SOURCE Solutions

- ✓ Global Sourcing Solution
- ✓ Obsolete Management
- ✓ Cost Control Management
- ✓ Shortage Management
- ✓ Alternative Solution
- ✓ Excess Inventory Management