



**THE DATASHEET OF  
NCP1607BDR2G**



# NCP1607

## Cost Effective Power Factor Controller

The NCP1607 is an active power factor controller specifically designed for use as a pre-converter in ac-dc adapters, electronic ballasts, and other medium power off line converters (typically up to 250 W). It utilizes Critical Conduction Mode (CRM) to ensure unity power factor across a wide range of input voltages and power levels. The NCP1607 minimizes the number of external components. The integration of comprehensive safety protection features makes it an excellent choice for designing robust PFC stages. It is available in a SOIC-8 package.

### General Features

- “Unity” Power Factor
- No Need for Input Voltage Sensing
- Latching PWM for Cycle by Cycle On Time Control (Voltage Mode)
- High Precision Voltage Reference ( $\pm 1.6\%$  over the Temperature Range)
- Very Low Startup Current Consumption ( $\leq 40 \mu\text{A}$ )
- Low Typical Operating Current (2.1 mA)
- Source 500 mA / Sink 800 mA Totem Pole Gate Driver
- Undervoltage Lockout with Hysteresis
- Pin to Pin Compatible with Industry Standards
- This is a Pb-Free Device
- This Device uses Halogen-Free Molding Compound

### Safety Features

- Programmable Overvoltage Protection
- Open Feedback Loop Protection
- Accurate and Programmable On Time Control
- Accurate Overcurrent Detector

### Typical Applications

- AC-DC Adapters, TVs, Monitors
- Off Line Appliances Requiring Power Factor Correction
- Electronic Light Ballast



ON Semiconductor®

[www.onsemi.com](http://www.onsemi.com)



SO-8  
D SUFFIX  
CASE 751

### MARKING DIAGRAMS

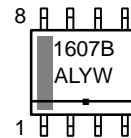

- A = Assembly Location
- L = Wafer Lot
- Y = Year
- W = Work Week
- = Pb-Free Package

### PIN CONNECTION

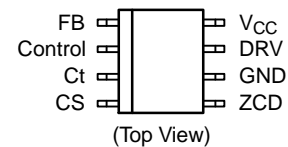

### ORDERING INFORMATION

Device	Package	Shipping†
NCP1607BDR2G	SOIC-8 (Pb-Free)	2500 / Tape & Reel

†For information on tape and reel specifications, including part orientation and tape sizes, please refer to our Tape and Reel Packaging Specifications Brochure, BRD8011/D.

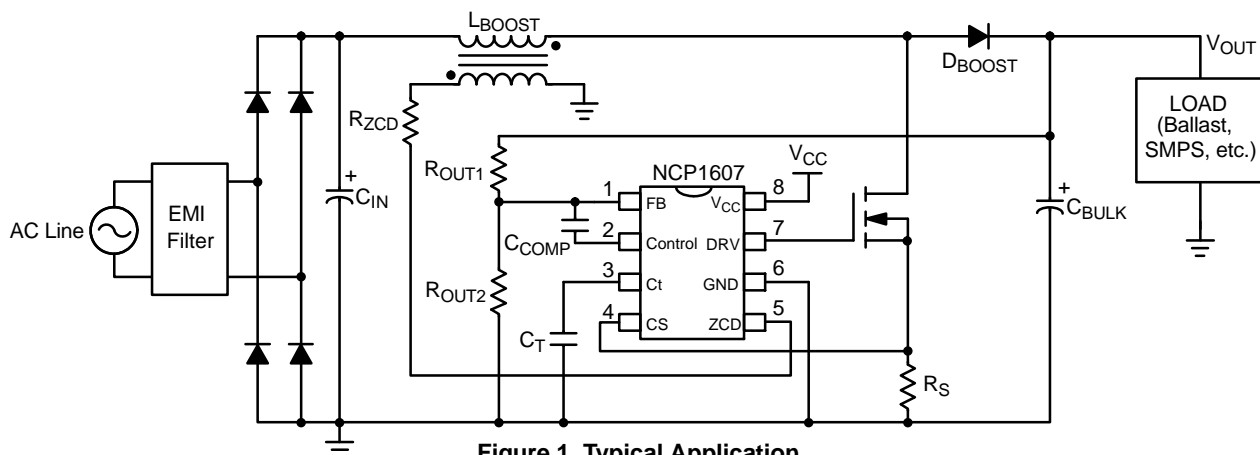

Figure 1. Typical Application

# NCP1607

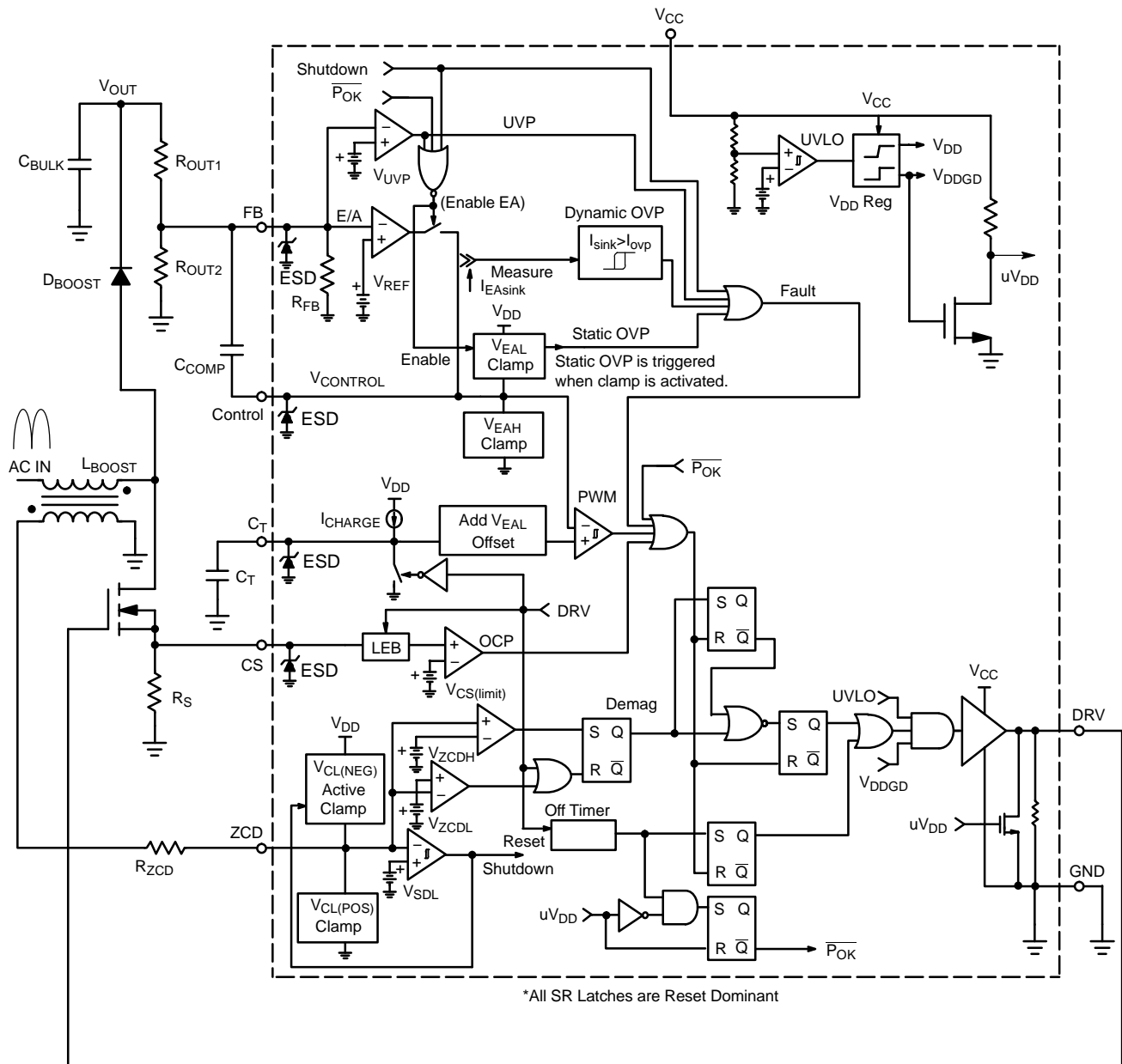

Figure 2. Block Diagram

# NCP1607

## PIN FUNCTION DESCRIPTION

Pin	Name	Function
1	FB	The FB pin is the inverting input of the internal error amplifier. An external resistor divider scales the output voltage to the internal reference voltage to maintain regulation. The feedback information is also used for the programmable overvoltage and undervoltage protections. The controller is disabled when this pin is below the undervoltage protection threshold, $V_{UVB}$ , typically 0.3 V.
2	Control	The Control pin is the output of the internal error amplifier. A compensation network is placed between the Control and FB pins to set the loop bandwidth. A low enough bandwidth is needed to obtain a high power factor ratio and a low THD.
3	Ct	The Ct pin sources a current to charge an external timing capacitor. The circuit controls the power switch on time by comparing the Ct voltage to an internal voltage derived from the regulation block. The Ct pin discharges the external timing capacitor at the end of the switching cycle.
4	CS	The CS pin limits the cycle-by-cycle current through the power switch. When the CS voltage exceeds the internal threshold, the MOSFET driver turns off. The sense resistor that connects to the CS pin programs the maximum switch current.
5	ZCD	The voltage of an auxiliary winding is applied to this pin to detect when the inductor is demagnetized for critical conduction mode operation. The controller is disabled when this pin is grounded.
6	GND	Analog ground.
7	DRV	Integrated MOSFET driver capable of driving a high gate charge power MOSFET.
8	$V_{CC}$	The $V_{CC}$ pin is the positive supply of the controller. The controller is enabled when $V_{CC}$ exceeds $V_{CC(on)}$ and remains enabled until $V_{CC}$ decreases below $V_{CC(off)}$ .

## MAXIMUM RATINGS

Rating	Symbol	Value	Unit
Supply Voltage	$V_{CC}$	-0.3 to 20	V
Supply Current	$I_{CC}$	$\pm 20$	mA
DRV Voltage	$V_{DRV}$	-0.3 to 20	V
DRV Sink Current	$I_{DRV(sink)}$	800	mA
DRV Source Current	$I_{DRV(source)}$	500	mA
FB Voltage	$V_{FB}$	-0.3 to 10	V
FB Current	$I_{FB}$	$\pm 10$	mA
Control Voltage	$V_{CONTROL}$	-0.3 to 10	V
Control Current	$I_{CONTROL}$	-2 to 10	mA
Ct Voltage	$V_{Ct}$	-0.3 to 6	V
Ct Current	$I_{Ct}$	$\pm 10$	mA
CS Voltage	$V_{CS}$	-0.3 to 6	V
CS Current	$I_{CS}$	$\pm 10$	mA
ZCD Voltage	$V_{ZCD}$	-0.3 to 10	V
ZCD Current	$I_{ZCD}$	$\pm 10$	mA
Power Dissipation and Thermal Characteristics D suffix, Plastic Package, Case 751 Maximum Power Dissipation @ $T_A = 70^\circ\text{C}$ Thermal Resistance Junction-to-Air	$P_D(SO)$ $R_{\theta JA}(SO)$	450 178	mW $^\circ\text{C/W}$
Operating Junction Temperature Range	$T_J$	-40 to 125	$^\circ\text{C}$
Maximum Junction Temperature	$T_{J(MAX)}$	150	$^\circ\text{C}$
Storage Temperature Range	$T_{STG}$	-65 to 150	$^\circ\text{C}$
Lead Temperature (Soldering, 10 s)	$T_L$	300	$^\circ\text{C}$

Stresses exceeding those listed in the Maximum Ratings table may damage the device. If any of these limits are exceeded, device functionality should not be assumed, damage may occur and reliability may be affected.

- This device series contains ESD protection and exceeds the following tests:  
Pins 1 – 8: Human Body Model 2000 V per JEDEC Standard JESD22-A114E,  
Charged Device Model 1000 V per JEDEC Standard JESD22-C101E.
- This device contains latch-up protection and exceeds  $\pm 100$  mA per JEDEC Standard JESD78.

# NCP1607

## ELECTRICAL CHARACTERISTICS

(For typical values,  $T_J = 25^\circ\text{C}$ . For min/max values,  $T_J = -40^\circ\text{C}$  to  $+125^\circ\text{C}$ , unless otherwise specified,

$V_{CC} = 12\text{ V}$ ,  $V_{FB} = 2.4\text{ V}$ ,  $V_{CS} = 0\text{ V}$ ,  $V_{CONTROL} = \text{open}$ ,  $V_{ZCD} = \text{open}$ ,  $C_{DRV} = 1\text{ nF}$ ,  $C_T = 1\text{ nF}$ )

Characteristics	Symbol	Min	Typ	Max	Unit
-----------------	--------	-----	-----	-----	------

### V<sub>CC</sub> UNDERVOLTAGE LOCKOUT SECTION

V <sub>CC</sub> Startup Threshold (Undervoltage Lockout Threshold, V <sub>CC</sub> rising) -25°C < T <sub>J</sub> < +125°C -40°C < T <sub>J</sub> < +125°C	V <sub>CC(on)</sub>	11.0 10.9	11.8 11.8	13.0 13.1	V
V <sub>CC</sub> Disable Voltage after Turn On (Undervoltage Lockout Threshold, V <sub>CC</sub> falling) -25°C < T <sub>J</sub> < +125°C -40°C < T <sub>J</sub> < +125°C	V <sub>CC(off)</sub>	8.7 8.5	9.5 9.5	10.3 10.5	V
Undervoltage Lockout Hysteresis	H <sub>UVLO</sub>	2.2	2.5	2.8	V

### DEVICE CONSUMPTION

I <sub>CC</sub> consumption during startup: $0\text{ V} < V_{CC} < V_{CC(on)} - 200\text{ mV}$	I <sub>CC(startup)</sub>	-	23.5	40	μA
I <sub>CC</sub> consumption after turn on at No Load, 70 kHz switching	I <sub>CC1</sub>	-	1.4	2.0	mA
I <sub>CC</sub> consumption after turn on at 70 kHz switching	I <sub>CC2</sub>	-	2.17	3.0	mA
I <sub>CC</sub> consumption after turn on at no switching (such as during OVP fault, UVP fault, or grounding ZCD)	I <sub>CC(fault)</sub>	-	1.2	1.6	mA

### REGULATION BLOCK (ERROR AMPLIFIER)

Voltage Reference $T_J = 25^\circ\text{C}$ -25°C < T <sub>J</sub> < +125°C -40°C < T <sub>J</sub> < +125°C	V <sub>REF</sub>	2.475 2.465 2.460	2.50 2.50 2.50	2.525 2.535 2.540	V
V <sub>REF</sub> Line Regulation from V <sub>CC(on)</sub> + 200 mV < V <sub>CC</sub> < 20 V, T <sub>J</sub> = 25°C	V <sub>REF(line)</sub>	-2.0	-	2.0	mV
Error Amplifier Current Capability: (Note 3) Sink (V <sub>Control</sub> = 4 V, V <sub>FB</sub> = 2.6 V): Source (V <sub>Control</sub> = 4 V, V <sub>FB</sub> = 2.4 V):	I <sub>EA</sub>	8.0 -2.0	17 -6.0	- -	mA
Error Amplifier Open Loop DC Gain (Note 4)	G <sub>OL</sub>	-	80	-	dB
Unity Gain Bandwidth (Note 4)	BW	-	1.0	-	MHz
FB Bias Current (V <sub>FB</sub> = 2.5 V)	I <sub>FB</sub>	0.25	0.53	1.25	μA
FB Pull Down Resistor (V <sub>FB</sub> = 2.5 V)	R <sub>FB</sub>	2.0	4.7	10	MΩ
Control Pin Bias Current (FB = 0 V and V <sub>CONTROL</sub> = 4.0 V)	I <sub>CONTROL</sub>	-1.0	-	1.0	μA
V <sub>CONTROL</sub> (I <sub>EASOURCE</sub> = 0.5 mA, V <sub>FB</sub> = 2.4 V)	V <sub>EAH</sub>	4.9	5.3	5.7	V
V <sub>CONTROL</sub> (I <sub>EASINK</sub> = 0.5 mA, V <sub>FB</sub> = 2.6 V)	V <sub>EAL</sub>	1.85	2.1	2.4	V
V <sub>EA(diff)</sub> = V <sub>EAH</sub> - V <sub>EAL</sub>	V <sub>EA(diff)</sub>	3.0	3.2	3.4	V

### CURRENT SENSE BLOCK

Overcurrent Voltage Threshold	V <sub>CS(limit)</sub>	0.45	0.5	0.55	V
Leading Edge Blanking Duration	t <sub>LEB</sub>	150	256	350	ns
Overcurrent Voltage Propagation Delay	t <sub>CS</sub>	40	100	170	ns
CS Bias Current (V <sub>CS</sub> = 2 V)	I <sub>CS</sub>	-1.0	-	1.0	μA

### ZERO CURRENT DETECTION

Zero Current Detection Threshold (V <sub>ZCD</sub> rising)	V <sub>ZCDH</sub>	1.9	2.1	2.3	V
Zero Current Detection Threshold (V <sub>ZCD</sub> falling)	V <sub>ZCDL</sub>	1.45	1.6	1.75	V
V <sub>ZCDH</sub> - V <sub>ZCDL</sub>	V <sub>ZCD(HYS)</sub>	300	500	800	mV
Maximum ZCD bias Current (V <sub>ZCD</sub> = 5 V)	I <sub>ZCD</sub>	-2.0	-	+2.0	μA
Upper Clamp Voltage (I <sub>ZCD</sub> = 2.5 mA)	V <sub>CL(POS)</sub>	5.0	5.7	6.5	V
Current Capability of the Positive Clamp at V <sub>ZCD</sub> = V <sub>CL(POS)</sub> + 200 mV:	I <sub>CL(POS)</sub>	5.0	8.5	-	mA
Negative Active Clamp Voltage (I <sub>ZCD</sub> = -2.5 mA)	V <sub>CL(NEG)</sub>	0.45	0.6	0.75	V

3. Parameter values are valid for transient conditions only.

4. Parameter characterized and guaranteed by design, but not tested in production.

# NCP1607

## ELECTRICAL CHARACTERISTICS

(For typical values,  $T_J = 25^\circ\text{C}$ . For min/max values,  $T_J = -40^\circ\text{C}$  to  $+125^\circ\text{C}$ , unless otherwise specified,  $V_{CC} = 12\text{ V}$ ,  $V_{FB} = 2.4\text{ V}$ ,  $V_{CS} = 0\text{ V}$ ,  $V_{CONTROL} = \text{open}$ ,  $V_{ZCD} = \text{open}$ ,  $C_{DRV} = 1\text{ nF}$ ,  $C_T = 1\text{ nF}$ )

Characteristics	Symbol	Min	Typ	Max	Unit
Current Capability of the Negative Active Clamp: in normal mode ( $V_{ZCD} = 300\text{ mV}$ ) in shutdown mode ( $V_{ZCD} = 100\text{ mV}$ )	$I_{CL(NEG)}$	2.5 35	3.7 70	5.0 100	mA $\mu\text{A}$
Shutdown Threshold ( $V_{ZCD}$ falling)	$V_{SDL}$	150	205	250	mV
Enable Threshold ( $V_{ZCD}$ rising)	$V_{SDH}$	–	290	350	mV
Shutdown Comparator Hysteresis	$V_{SD(HYS)}$	–	85	–	mV
Zero Current Detection Propagation Delay	$t_{ZCD}$	–	100	170	ns
Minimum Detectable ZCD Pulse Width	$t_{SYNC}$	–	70	–	ns
Drive off Restart Timer	$t_{START}$	75	179	300	$\mu\text{s}$

## RAMP CONTROL

Ct Charge Current ( $V_{CT} = 0\text{ V}$ )	$I_{CHARGE}$	$-25^\circ\text{C} < T_J < +125^\circ\text{C}$ $-40^\circ\text{C} < T_J < +125^\circ\text{C}$	243 235	270 270	297 297	$\mu\text{A}$
Time to discharge a 1 nF Ct capacitor from $V_{CT} = 3.4\text{ V}$ to 100 mV.	$t_{CT(\text{discharge})}$		–	–	100	ns
Maximum Ct level before DRV switches off	$V_{CTMAX}$	$-25^\circ\text{C} < T_J < +125^\circ\text{C}$ $-40^\circ\text{C} < T_J < +125^\circ\text{C}$	2.9 2.9	3.2 3.2	3.3 3.4	V
PWM Propagation Delay	$t_{PWM}$		–	142	220	ns

## OVER AND UNDERVOLTAGE PROTECTION

Dynamic Overvoltage Protection (OVP) Triggering Current: $T_J = 25^\circ\text{C}$ $T_J = -40^\circ\text{C}$ to $+125^\circ\text{C}$	$I_{OVP}$		9.0 8.7	10.5 –	11.8 12.1	$\mu\text{A}$
Hysteresis of the dynamic OVP current before the OVP latch is released	$I_{OVP(HYS)}$		–	8.5	–	$\mu\text{A}$
Static OVP Threshold Voltage	$V_{OVP}$		–	$V_{EAL} + 100\text{ mV}$	–	V
Undervoltage Protection (UVP) Threshold Voltage	$V_{UVP}$		0.25	0.302	0.4	V

## GATE DRIVE SECTION

Gate Drive Resistance: $R_{OH}$ @ $I_{SOURCE} = 100\text{ mA}$ $R_{OL}$ @ $I_{SINK} = 100\text{ mA}$	$R_{OH}$ $R_{OL}$		– –	12 6.0	18 10	$\Omega$
Drive voltage rise time from 10% $V_{CC}$ to 90% $V_{CC}$	$t_{rise}$		–	30	80	ns
Drive voltage fall time from 90% $V_{CC}$ to 10% $V_{CC}$	$t_{fall}$		–	25	70	ns
Driver output voltage at $V_{CC} = V_{CC(on)} - 200\text{ mV}$ and $I_{sink} = 10\text{ mA}$	$V_{OUT(\text{start})}$		–	–	0.2	V

- Parameter values are valid for transient conditions only.
- Parameter characterized and guaranteed by design, but not tested in production.

Product parametric performance is indicated in the Electrical Characteristics for the listed test conditions, unless otherwise noted. Product performance may not be indicated by the Electrical Characteristics if operated under different conditions.

TYPICAL CHARACTERISTICS

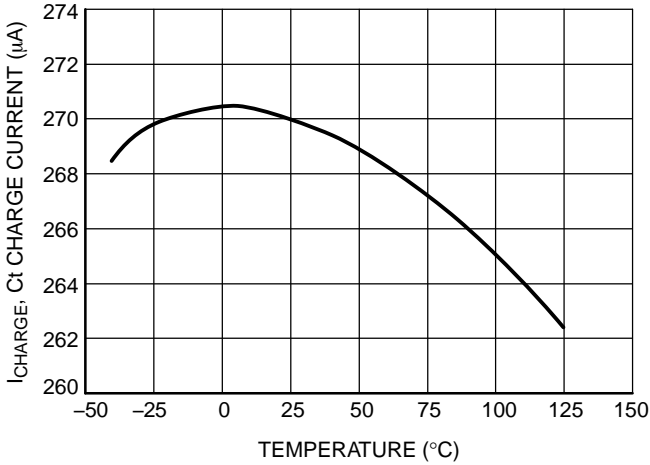

Figure 3. Ct Charge Current vs. Temperature

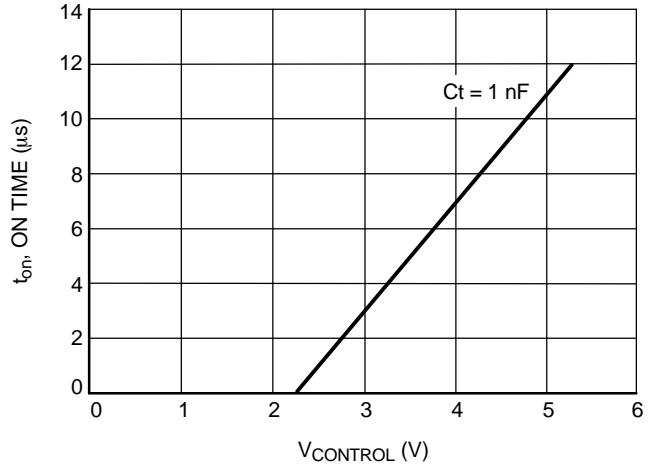

Figure 4. On Time vs. V<sub>CONTROL</sub> Level

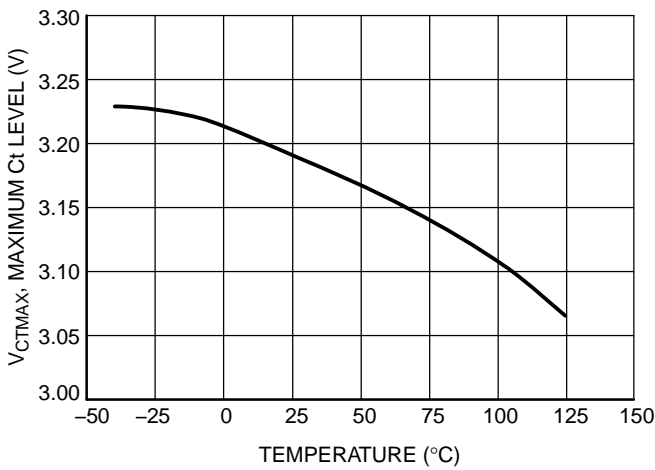

Figure 5. Maximum Ct Level vs. Temperature

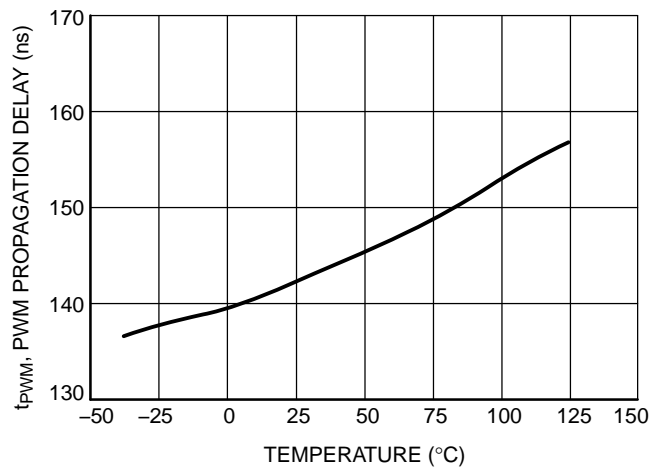

Figure 6. PWM Propagation Delay vs. Temperature

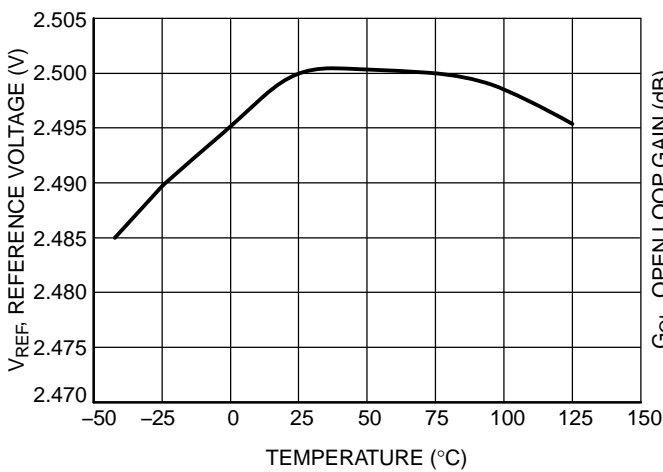

Figure 7. Reference Voltage vs. Temperature

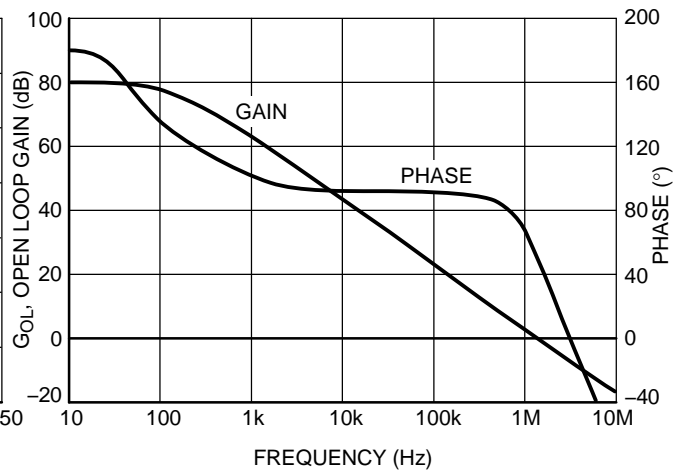

Figure 8. Error Amplifier Open Loop Gain and Phase

TYPICAL CHARACTERISTICS

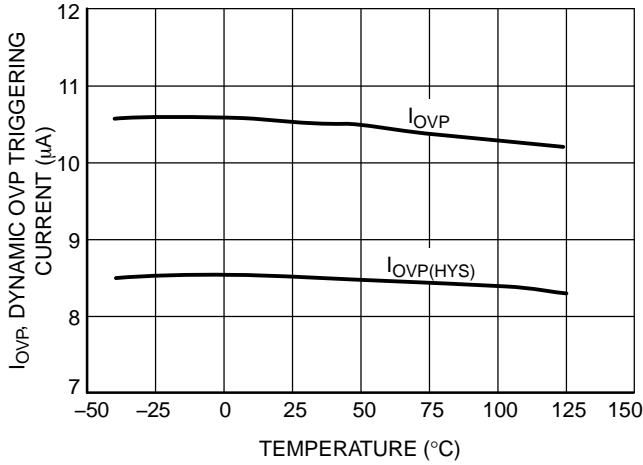

Figure 9. Dynamic OVP Triggering Current vs. Temperature

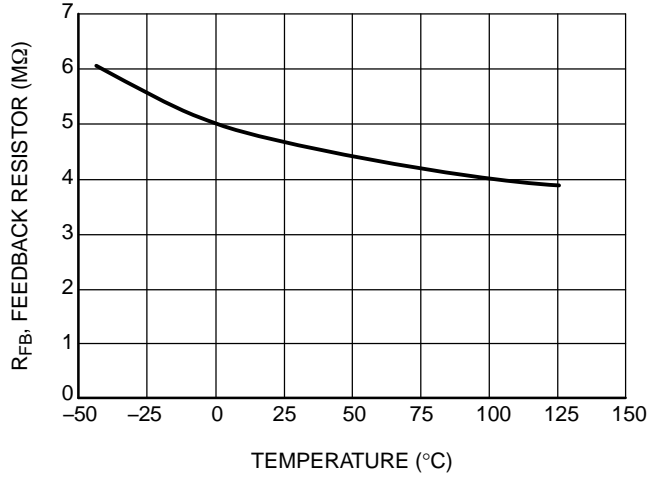

Figure 10. Feedback Resistor vs. Temperature

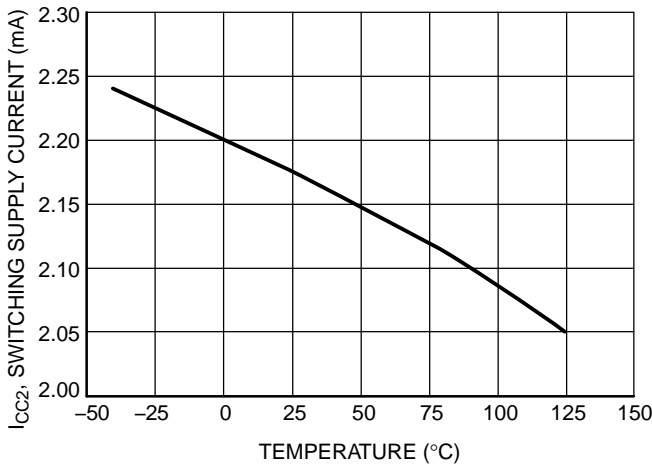

Figure 11. Switching Supply Current vs. Temperature

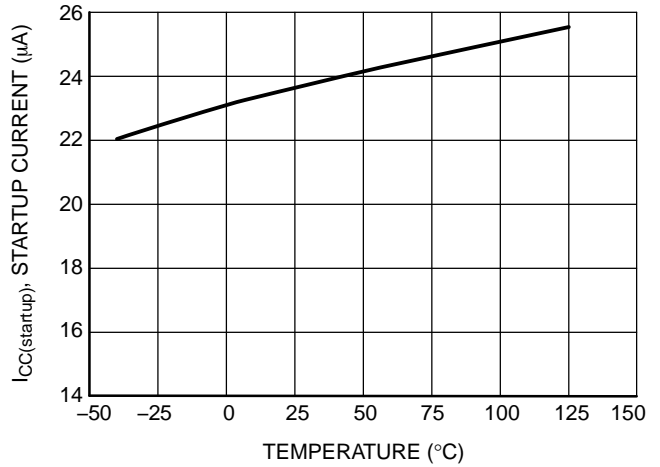

Figure 12. Startup Current vs. Temperature

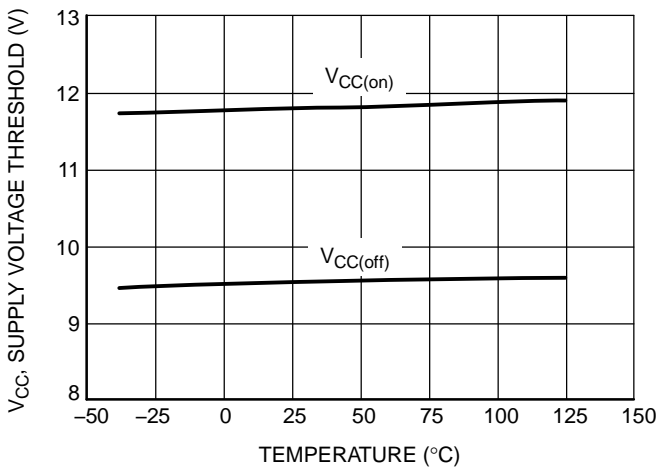

Figure 13. Supply Voltage Thresholds vs. Temperature

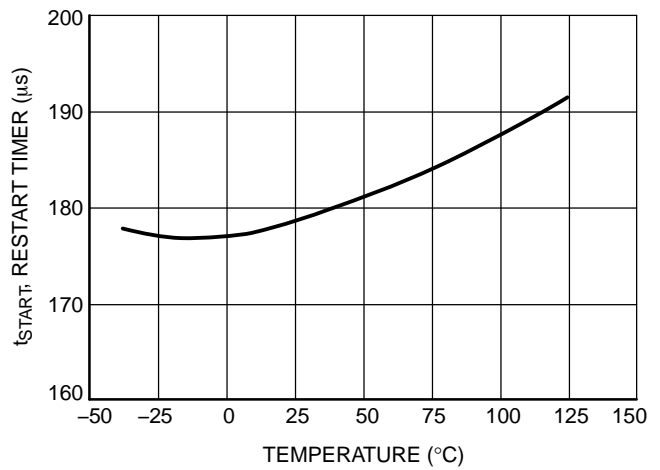

Figure 14. Restart Timer vs. Temperature

TYPICAL CHARACTERISTICS

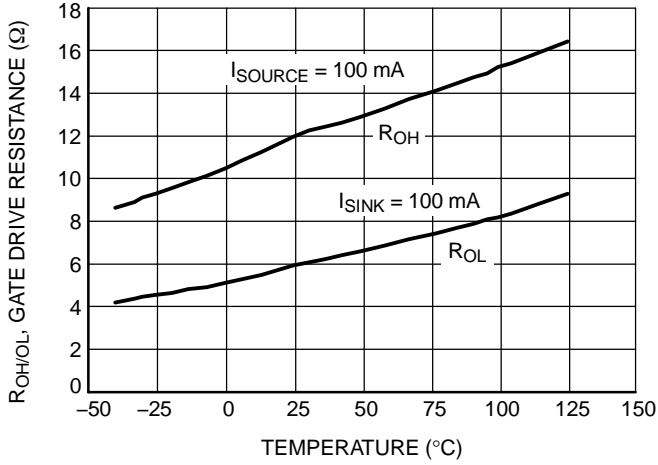

Figure 15. Gate Drive Resistance vs. Temperature

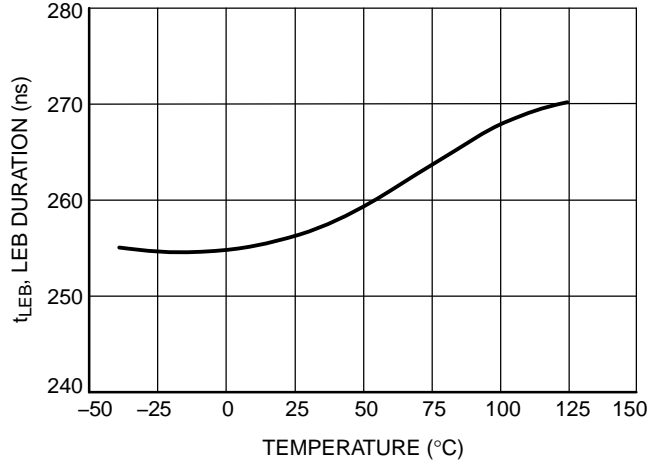

Figure 16. LEB Duration vs. Temperature

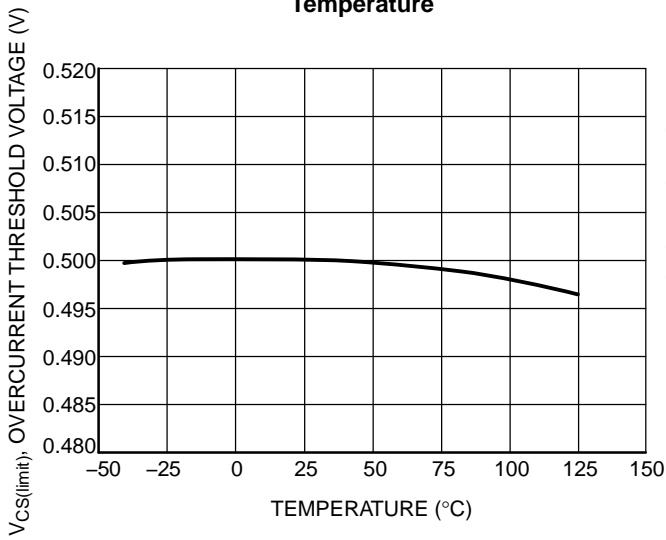

Figure 17. Overcurrent Threshold Voltage vs. Temperature

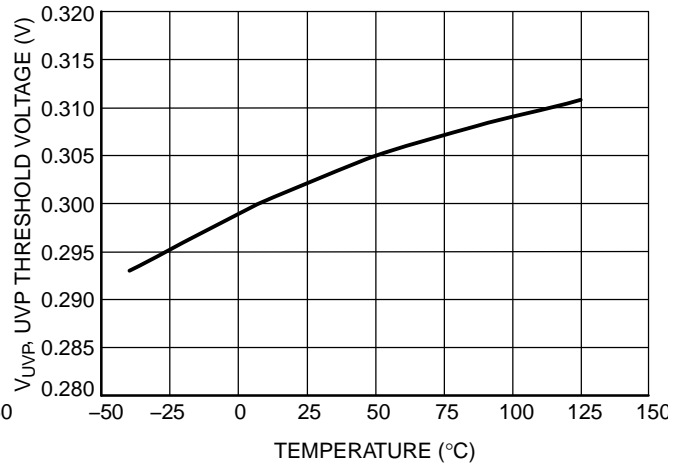

Figure 18. Undervoltage Protection Threshold Voltage vs. Temperature

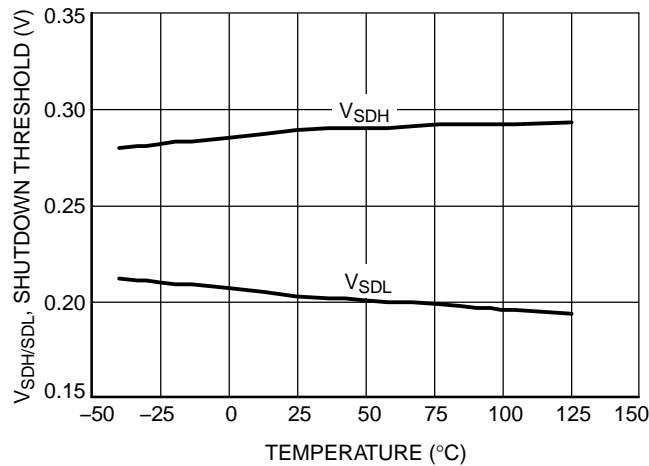

Figure 19. Shutdown Thresholds vs. Temperature

**Introduction**

The NCP1607 is a voltage mode power factor correction (PFC) controller designed to drive cost effective pre-converters to meet input line harmonic regulations. This controller operates in critical conduction mode (CRM) for optimal performance in applications up to 250 W. Its voltage mode scheme enables it to obtain unity power factor without the need for a line sensing network. The output voltage is accurately controlled by a high precision error amplifier. The controller also implements a comprehensive array of safety features for robust designs. The key features of the NCP1607 are as follows:

- Constant on time (Voltage Mode) CRM operation. High power factor ratios are easily obtained without the need for input voltage sensing. This allows for optimal standby power consumption.
- Accurate and Programmable On Time Limitation. The NCP1607 uses an accurate current source and an external capacitor to generate the on time.
- High Precision Voltage Reference. The error amplifier reference voltage is guaranteed at  $2.5\text{ V} \pm 1.6\%$  over process, temperature, and voltage supply levels. This results in very accurate output voltages.
- Very Low Startup Current Consumption. The circuit consumption is reduced to a minimum ( $< 40\ \mu\text{A}$ ) during the startup phase, allowing fast, low loss, charging of  $V_{CC}$ . The architecture of the NCP1607 gives a controlled undervoltage lockout level and provides ample  $V_{CC}$  hysteresis during startup.
- Powerful Output Driver. A Source 500 mA / Sink 800 mA totem pole gate driver is used to provide rapid turn on and turn off times. This allows for improved efficiencies and the ability to drive higher power MOSFETs. Additionally, a combination of active and passive circuitry is used to ensure that the driver output voltage does not float high while  $V_{CC}$  is below its turn on level.
- Programmable Overvoltage Protection (OVP). The adjustable OVP feature protects the PFC stage against excessive output overshoots that could damage the application. These events can typically occur during the startup phase or when the load is abruptly removed.
- Protection against Open Feedback Loop (Undervoltage Protection). Undervoltage protection (UVP) disables the PFC stage when the output voltage is excessively low. This also protects the circuit in case of a failure in the feedback network: if no voltage is applied to FB because of a poor connection or if the FB pin is floating, UVP is activated shutting down the converter.
- Overcurrent Limitation. The peak current is accurately limited on a pulse by pulse basis. The level is adjustable by modifying the current sense resistor. An

integrated LEB filter reduces the chance of noise prematurely triggering the overcurrent limit.

- Shutdown Features. The PFC pre-convertor is placed in a shutdown mode by grounding the FB pin or the ZCD pin. During this mode, the  $I_{CC}$  current consumption is reduced and the error amplifier is disabled.

**Application information**

Most electronic ballasts and switching power supplies use a diode bridge rectifier and a bulk storage capacitor to produce a dc voltage from the utility ac line (Figure 20). This DC voltage is then processed by additional circuitry to drive the desired output.

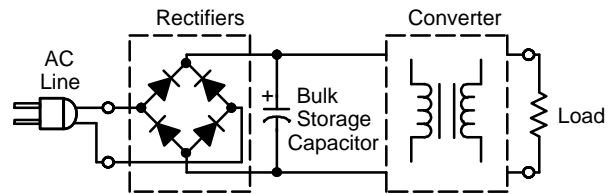

**Figure 20. Typical Circuit without PFC**

This simple rectifying circuit draws power from the line when the instantaneous ac voltage exceeds the capacitor voltage. Since this occurs near the line voltage peak, the resulting current draw is non sinusoidal and contains a very high harmonic content. This results in a poor power factor (typically  $< 0.6$ ) and consequently, the apparent input power is much higher than the real power delivered to the load. Additionally, if multiple devices are tied to the same input line, the effect is magnified and a “line sag” effect can be produced (see Figure 21).

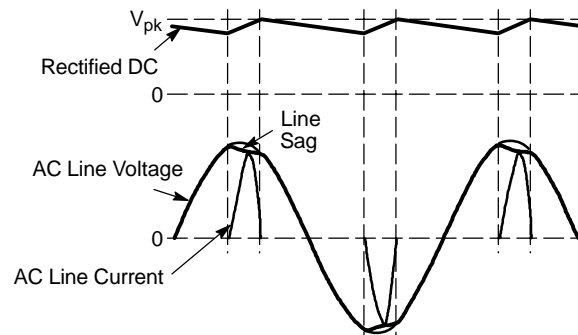

**Figure 21. Typical Line Waveforms without PFC**

Increasingly, government regulations and utility requirements necessitate control over the line current harmonic content. To meet this need, power factor correction is implemented with either a passive or active circuit. Passive circuits usually contain a combination of large capacitors, inductors, and rectifiers that operate at the ac line frequency. Active circuits incorporate some form of a high frequency switching converter that regulates the

## NCP1607

input current to stay in phase with the input voltage. These circuits operate at a higher frequency and so they are smaller, lighter in weight, and more efficient than a passive circuit. With proper control of an active PFC stage, almost any complex load can be made to appear in phase with the ac line, thus significantly reducing the harmonic current

content. Because of these advantages, active PFC circuits have become the most popular way to meet harmonic content requirements. Generally, they consist of inserting a PFC pre-regulator between the rectifier bridge and the bulk capacitor (Figure 22).

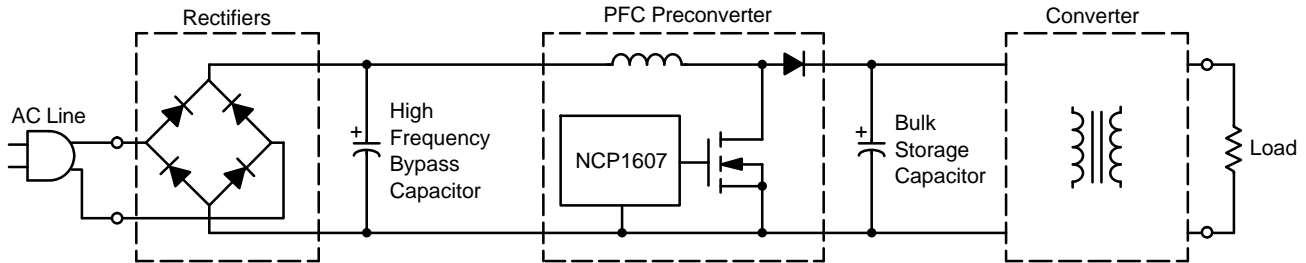

Figure 22. Active PFC Pre-Converter with the NCP1607

The boost (or step up) converter is the most popular topology for active power factor correction. With the proper control, it produces a constant voltage while drawing a sinusoidal current from the line. For medium power (<300 W) applications, critical conduction mode (also called borderline conduction mode) is the preferred control method. Critical conduction mode (CRM) occurs at the boundary between discontinuous conduction mode

(DCM) and continuous conduction mode (CCM). In CRM, the next driver on time is initiated when the boost inductor current reaches zero. CRM operation is an ideal choice for medium power PFC boost stages because it combines the lower peak currents of CCM operation with the zero current switching of DCM operation. The operation and waveforms in a PFC boost converter are illustrated in Figure 23.

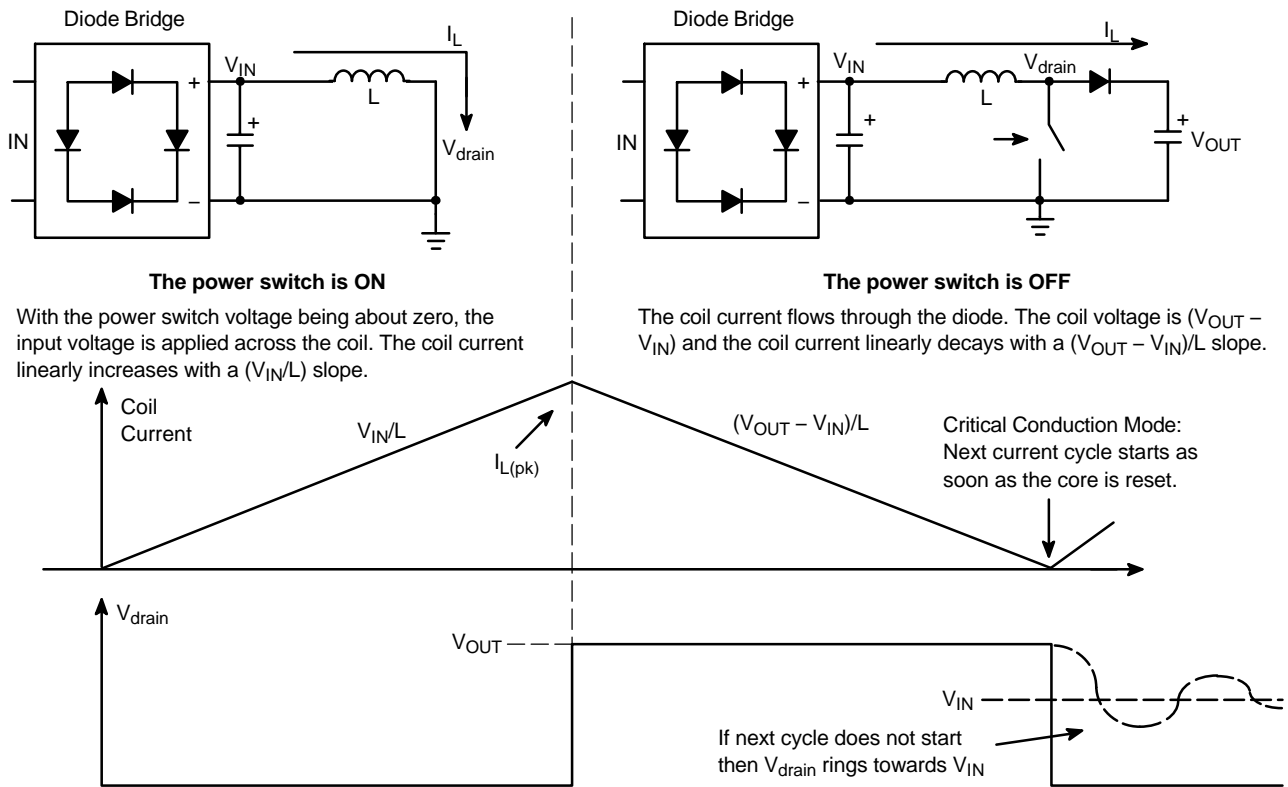

Figure 23. Schematic and Waveforms of an Ideal CRM Boost Converter

When the switch is closed, the inductor current increases linearly to its peak value. When the switch opens, the inductor current linearly decreases to zero. At this point, the drain voltage of the switch ( $V_d$ ) is essentially floating and begins to drop. If the next switching cycle does not start, then the voltage will ring with a dampened frequency around  $V_{in}$ . A simple derivation of equations (such as found in AND8123), leads to the result that good power factor correction in CRM operation is achieved when the on time is constant across an ac cycle and is equal to:

$$t_{on} = \frac{2 \cdot P_{OUT} \cdot L}{\eta \cdot Vac^2} \quad (eq. 1)$$

A simple plot of this switching over an ac line cycle is illustrated in Figure 24. The off time varies based on the instantaneous line voltage, but the on time is kept constant. This naturally causes the peak inductor current ( $I_{L(pk)}$ ) to follow the ac line voltage.

The NCP1607 represents an ideal method to implement this constant on time CRM control in a cost effective and robust solution. The device incorporates an accurate regulation circuit, a low power startup circuit, and advanced protection features.

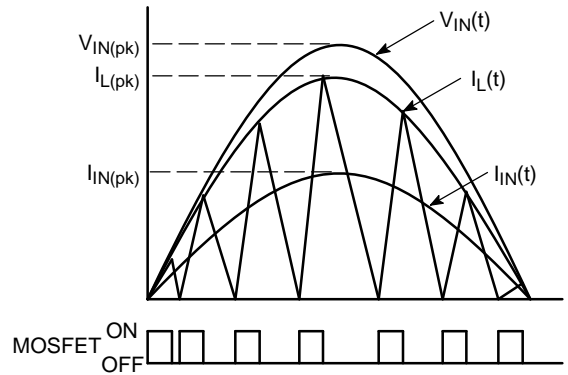

Figure 24. Inductor Waveform During CRM Operation

**ERROR AMPLIFIER REGULATION**

The NCP1607 is configured to regulate the boost output voltage based on its built in error amplifier (EA). The error amplifier’s negative terminal is pinned out to FB, the positive terminal is tied to a  $2.5V \pm 1.6\%$  reference, and the output is pinned out to Control (Figure 25).

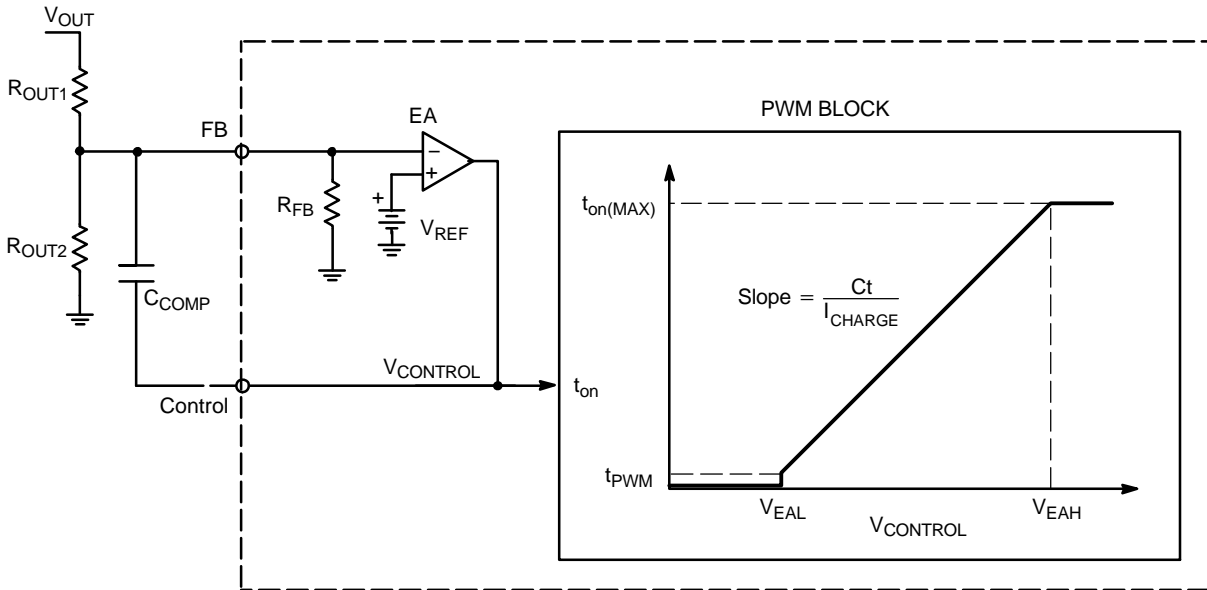

Figure 25. Error Amplifier and On Time Regulation Circuits

A resistor divider from the boost output to the input of the EA sets the FB level. If the output voltage is too low, then the FB level will drop and the EA will cause the control voltage to increase. This increases the on time of the driver, which increases the power delivered and brings the output back into regulation. Alternatively, if the output voltage (and hence FB voltage) is too high, then the control level decreases and the driver on times are shortened. In this way, the circuit regulates the output voltage ( $V_{OUT}$ ) so that the  $V_{OUT}$  portion that is applied to FB through the resistor

divider  $R_{OUT1}$  and  $R_{OUT2}$  is equal to the internal reference (2.5 V). The output voltage is set using Equation 2:

$$V_{OUT} = V_{REF} \cdot \left( \frac{R_{OUT1} + R_{EQ}}{R_{EQ}} \right) \quad (eq. 2)$$

Where  $R_{EQ}$  is the parallel combination of  $R_{OUT2}$  and  $R_{FB}$ .  $R_{EQ}$  is calculated using Equation 3:

$$R_{EQ} = \frac{R_{OUT2} \cdot R_{FB}}{R_{OUT2} + R_{FB}} \quad (eq. 3)$$

A compensation network is placed between the FB and Control pins to reduce the speed at which the EA responds to changes in the boost output. This is necessary due to the nature of an active PFC circuit. The PFC stage absorbs a sinusoidal current from a sinusoidal line voltage. Hence, the converter provides the load with a power that matches the average demand only. Therefore, the output capacitor must “absorb” the difference between the delivered power

and the power consumed by the load. This means that when the power fed to the load is lower than the demand, the output capacitor discharges to compensate for the lack of power. Alternatively, when the supplied power is higher than that absorbed by the load, the output capacitor charges to store the excess energy. The situation is depicted in Figure 26.

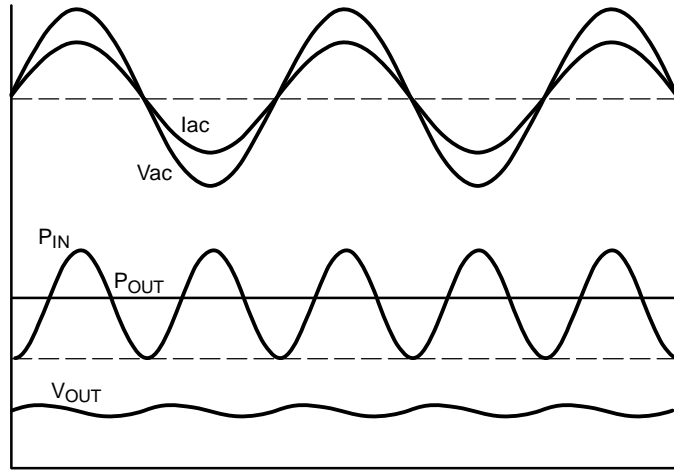

Figure 26. Output Voltage Ripple for a Constant Output Power

As a consequence, the output voltage exhibits a ripple at a frequency of either 100 Hz (for 50 Hz mains such as in Europe) or 120 Hz (for 60 Hz mains in the USA). This ripple must not be taken into account by the regulation loop because the error amplifier’s output voltage must be kept constant over a given ac line cycle for a proper shaping of the line current. Due to this constraint, the regulation bandwidth is typically set below 20 Hz. For a simple type 1 compensation network, only a capacitor is placed between FB and Control (see Figure 1). In this configuration, the capacitor necessary to attenuate the bulk voltage ripple is given by:

$$C_{COMP} = \frac{10^{\frac{G}{20}}}{4 \cdot \pi \cdot f_{line} \cdot R_{OUT1}} \quad (\text{eq. 4})$$

where G is the attenuation level in dB (commonly 60 dB)

**ON TIME SEQUENCE**

Since the NCP1607 is designed to control a CRM boost converter, its switching pattern must accommodate constant on times and variable off times. The Controller generates the on time via an external capacitor connected to pin 3 (Ct). A current source charges this capacitor to a level determined by the Control pin voltage. Specifically, Ct is charged to VCONTROL minus the VEAL offset (2.1 V typical). Once this level is exceeded, the drive is turned off (Figure 27).

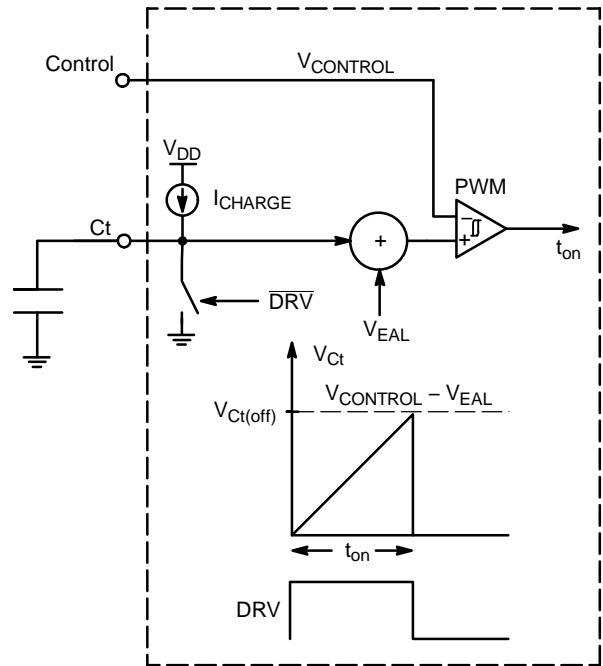

Figure 27. On Time Generation

Since VCONTROL varies with the RMS line level and output load, this naturally satisfies equation 1. And if the values of compensation components are sufficient to filter

out the bulk voltage ripple, then this on time is truly constant over the ac line cycle.

Note that the maximum on time of the controller occurs when  $V_{CONTROL}$  is at its maximum. Therefore, the  $C_t$  capacitor must be sized to ensure that the required on time can be delivered at full power and the lowest input voltage condition. The maximum on time is given by:

$$t_{on(MAX)} = \frac{C_t \cdot V_{CTMAX}}{I_{CHARGE}} \quad (\text{eq. 5})$$

Combining this equation with equation 1, gives:

$$C_t \geq \frac{2 \cdot P_{OUT} \cdot L \cdot I_{CHARGE}}{\eta \cdot V_{ac}^2 \cdot V_{CTMAX}} \quad (\text{eq. 6})$$

where  $V_{CTMAX} = 2.9 \text{ V (min)}$

$I_{CHARGE} = 297 \mu\text{A (max)}$

**OFF TIME SEQUENCE**

While the on time is constant across the ac cycle, the off time in CRM operation varies with the instantaneous input voltage. The NCP1607 determines the correct off time by sensing the inductor voltage. When the inductor current drops to zero, the drain voltage (“ $V_{drain}$ ” in Figure 23) is essentially floating and naturally begins to drop. If the switch is turned on at this moment, then CRM operation will be achieved. To measure this high voltage directly on the inductor is generally not economical or practical. Rather, a smaller winding is taken off of the boost inductor. This winding, called the zero current detector (ZCD) winding, gives a scaled version of the inductor output and is more useful to the controller.

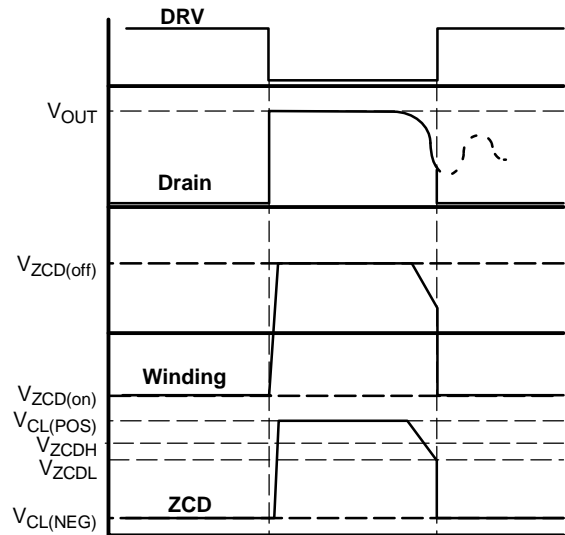

**Figure 28. Voltage Waveforms for Zero Current Detection**

Figure 28 gives typical operating waveforms with the ZCD winding. When the drive is on, a negative voltage appears on the ZCD winding. And when the drive is off, a positive voltage appears. When the inductor current drops to zero, then the ZCD voltage falls and starts to ring around zero volts. The NCP1607 detects this falling edge and starts the next driver on time. To ensure that a ZCD event has truly occurred, the NCP1607’s logic (Figure 29) waits for the ZCD pin voltage to rise above  $V_{ZCDH}$  (2.1 V typical) and then fall below  $V_{ZCDL}$  (1.6 V typical). In this way, CRM operation is easily achieved.

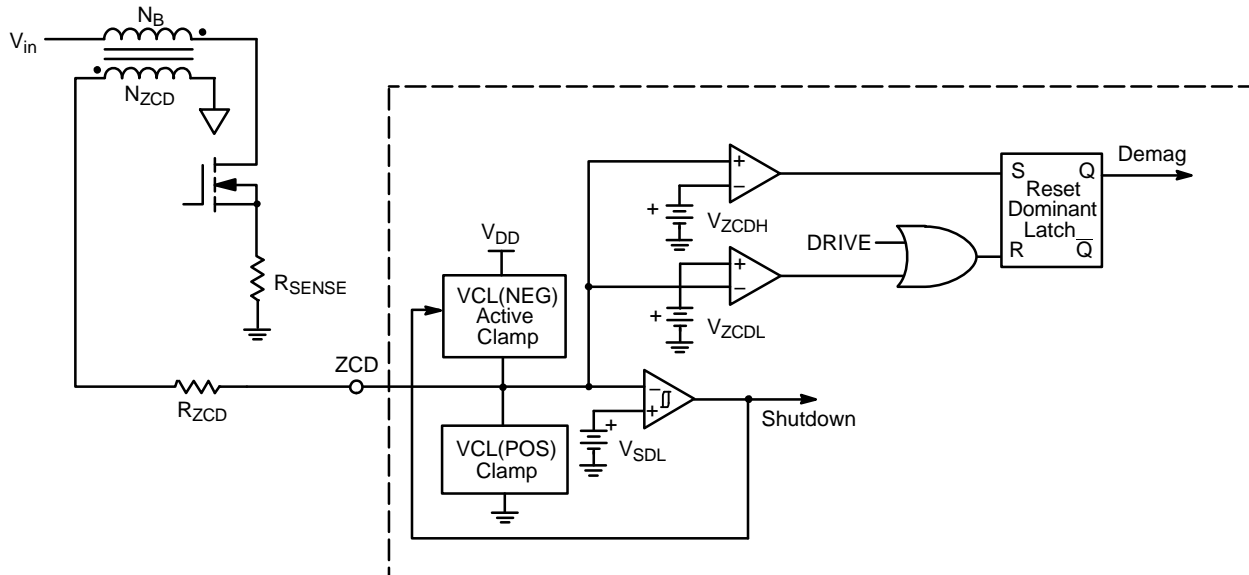

**Figure 29. Implementation of the ZCD Winding**

## NCP1607

To prevent negative voltages on the ZCD pin, the pin is internally clamped to  $V_{CL(NEG)}$  (600 mV typical) when the ZCD winding is negative. Similarly, the ZCD pin is clamped to  $V_{CL(POS)}$  (5.7 V typical), when the voltage rises too high. Because of these clamps, a resistor ( $R_{ZCD}$  in Figure 29) is necessary to limit the current from the ZCD winding to the ZCD pin.

At startup, there is no energy in the ZCD winding and therefore no voltage signal to activate the ZCD comparators. This means that the driver could never turn on. Therefore, to enable the PFC stage to startup under these conditions, an internal watchdog timer is integrated into the controller. This timer turns the drive on if the driver has been off for more than 180  $\mu$ s (typical). This feature is deactivated during a fault mode (OVP, UVP, or Shutdown), and reactivated when the fault is removed.

### STARTUP

Generally, a resistor connected between the ac input and  $V_{CC}$  (pin 8) charges the  $V_{CC}$  capacitor to the  $V_{CC(on)}$  level (12 V typical). Because of the very low consumption of the NCP1607 during this stage ( $< 40 \mu$ A), most of the current goes directly to charging up the  $V_{CC}$  capacitor. This provides faster startup times and reduced standby power dissipation. When the  $V_{CC}$  voltage exceeds the  $V_{CC(on)}$

level, the internal references and logic of the NCP1607 turn on. The controller has an undervoltage lockout (UVLO) feature which keeps the part active until  $V_{CC}$  drops below  $V_{CC(off)}$  (9.5 V typical). This hysteresis allows ample time for the auxiliary winding to take over and supply the necessary power to  $V_{CC}$  (Figure 30).

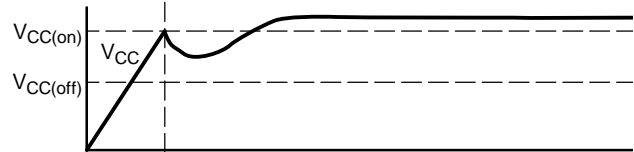

Figure 30. Typical  $V_{CC}$  Startup Waveform

When the PFC pre-converter is loaded by a switch mode power supply (SMPS), then it is often preferable to have the SMPS controller startup first. The SMPS can then supply the NCP1607  $V_{CC}$  directly. Advanced controllers, such as the NCP1230 or NCP1381, can control when to turn on the PFC stage (see Figure 31) leading to optimal system performance. This setup also eliminates the startup resistors and therefore improves the no load power dissipation of the system.

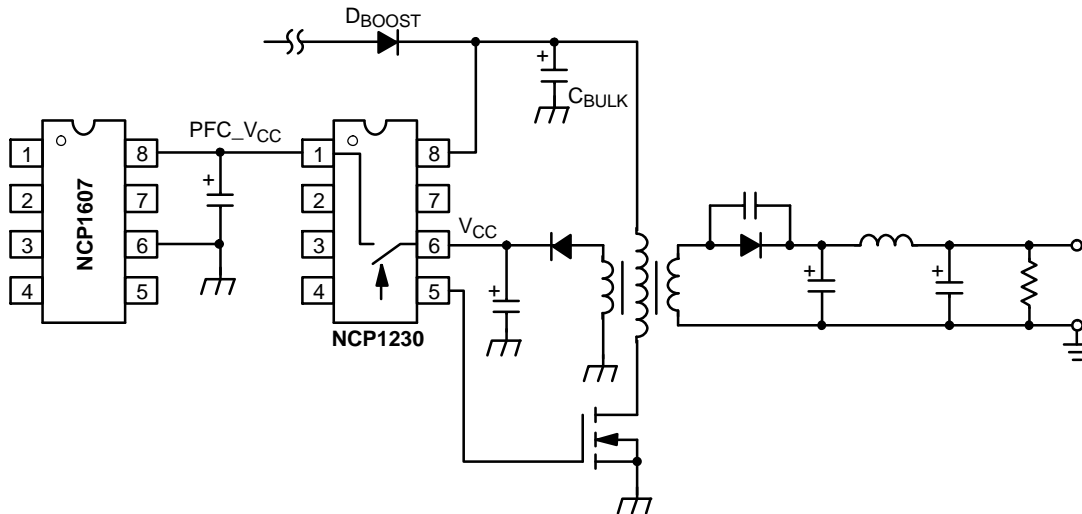

Figure 31. NCP1607 Supplied by a Downstream SMPS Controller (NCP1230)

### QUICK START and SOFT START

At startup, the error amplifier is enabled and Control is pulled up to  $V_{EAL}$  (2.1 V typical). This is the lowest level of control voltage which produces output drives. This feature, called “quick start,” eliminates the delay at startup

associated with charging the compensation network to its minimum level. This also produces a natural “soft-start” mode where the controller’s power ramps up from zero to the required power (see Figure 32).

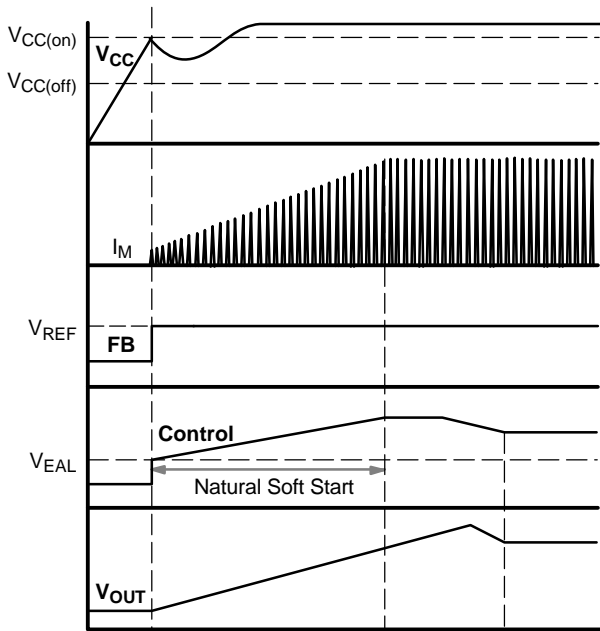

Figure 32. Startup Timing Diagram Showing the Natural Soft Start of the Control Pin

**OUTPUT DRIVER**

The NCP1607 includes a powerful output driver capable of peak currents of Source 500 mA / Sink 800 mA. This enables the controller to efficiently drive power MOSFETs for medium power (up to 300 W) applications. Additionally, the driver stage is equipped with both passive and active pull down clamps (Figure 33). The clamps are active when  $V_{CC}$  is off and force the driver output to well below the threshold voltage of a power MOSFET.

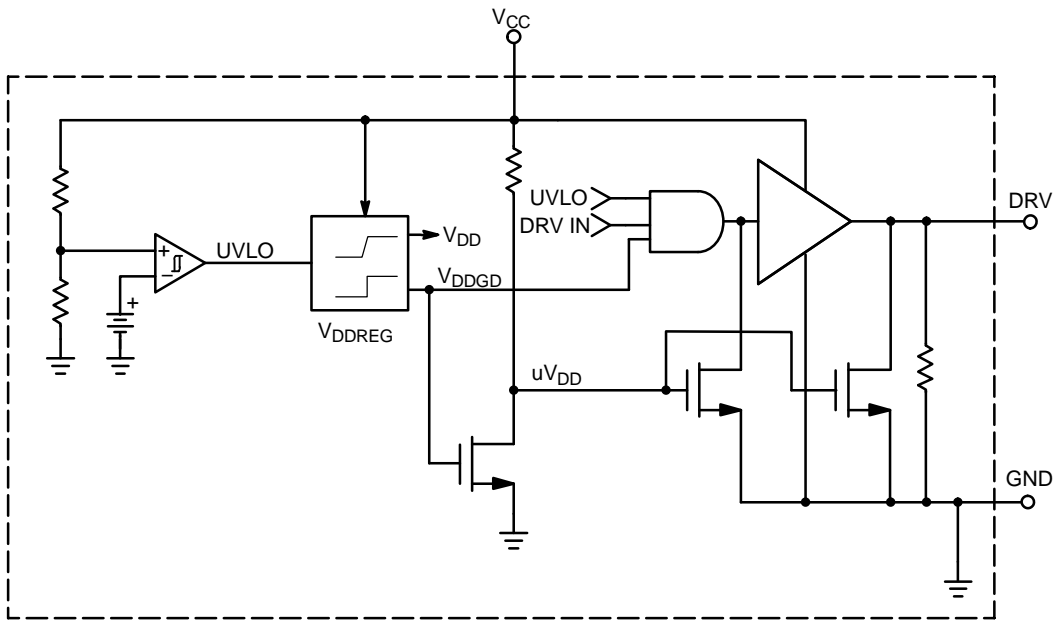

Figure 33. Output Driver Stage and Pull Down Clamps

**Overvoltage Protection**

The low bandwidth of the feedback network makes active PFC stages very slow systems. One consequence of this is the risk of huge overshoots in abrupt transient phases (startup, load steps, etc.). For reliable operation, it is critical that some form of overvoltage protection (OVP) effectively prevents the output voltage from rising too high. The NCP1607 detects these excessive  $V_{OUT}$  levels

and disables the driver until the output voltage returns to nominal levels. This keeps the output voltage within an acceptable range. The limit is adjustable so that the overvoltage level can be optimally set. The level must not be so low that it is triggered by the 100 or 120 Hz ripple of the output voltage, but it must be low enough so as not to require a larger voltage rating of the output capacitor. Figure 34 depicts the operation of the OVP circuitry.



**STATIC OVERVOLTAGE PROTECTION**

If the OVP condition lasts for a long time, it may happen that the error amplifier output reaches its minimum level (i.e. Control =  $V_{EAL}$ ). It would then not be able to sink any current and maintain the OVP fault. Therefore, to avoid any discontinuity in the OVP disabling effect, the circuit incorporates a comparator which detects when the lower level of the error amplifier is reached. This event, called “static OVP”, disables the output drives. Once the OVP event is over, and the output voltage has dropped to normal, then Control rises above the lower limit and the driver is re-enabled (Figure 35).

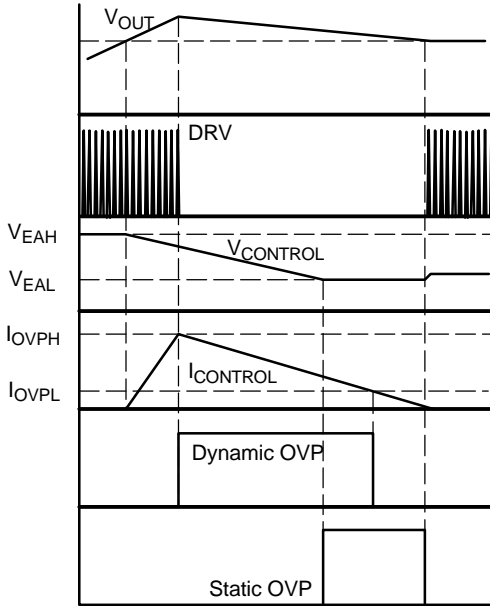

Figure 35. OVP Timing Diagram

**NCP1607 Undervoltage Protection (UVP)**

When the PFC stage is plugged in, the output voltage is forced to roughly equate the peak line voltage. The NCP1607 detects an undervoltage fault when this output voltage is unusually low, such that the feedback voltage is below  $V_{UVP}$  (300 mV typical). In an UVP fault, the drive output and error amplifier (EA) are disabled. The latter is done so that the EA does not source a current which would increase the FB voltage and prevent the UVP event from being accurately detected. The UVP feature helps to protect the application if something is wrong with the power path to the bulk capacitor (i.e. the capacitor cannot charge up) or if the controller cannot sense the bulk voltage (i.e. the feedback loop is open).

Furthermore, the NCP1607 incorporates a novel startup sequence which ensures that undervoltage conditions are always detected at startup. It accomplishes this by waiting approximately 180  $\mu$ s after  $V_{CC}$  reaches  $V_{CC(on)}$  before enabling the error amplifier (Figure 36). During this wait time, it looks to see if the feedback (FB) voltage is greater than the UVP threshold. If not, then the controller enters a UVP fault and leaves the error amplifier disabled.

However, if the FB pin voltage increases and exceeds the UVP level, then the controller will start the application up normally.

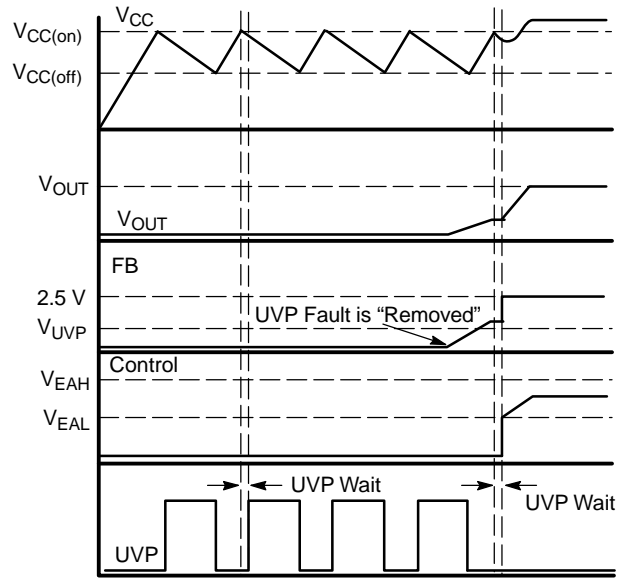

Figure 36. The NCP1607's Startup Sequence with and without a UVP Fault

The voltage on the output which exits a UVP fault is given by:

$$V_{OUT(UVP)} = \frac{R_{OUT1} + R_{EQ}}{R_{EQ}} \cdot V_{UVP} \quad (\text{eq. 15})$$

If  $R_{OUT1} = 4 \text{ M}\Omega$  and  $R_{EQ} = 25.16 \text{ k}\Omega$ , then the  $V_{OUT(UVP)}$  threshold is 48 V. This corresponds to an input voltage of approximately 34 Vac.

**Open Feedback Loop Protection**

The NCP1607 features comprehensive protection against open feedback loop conditions by including OVP, UVP, and Floating Pin Protection (FPP). Figure 37 illustrates three conditions in which the feedback loop is open. The corresponding number below describes each condition shown in Figure 37.

1. **UVP Protection:** The connection from resistor  $R_{OUT1}$  to the FB pin is open.  $R_{OUT2}$  pulls down the FB pin to ground. The UVP comparator detects a UVP fault and the drive is disabled.
2. **OVP Protection:** The connection from resistor  $R_{OUT2}$  to the FB pin is open.  $R_{OUT1}$  pulls up the FB pin to the output voltage. The ESD diode clamps the FB voltage to 10 V and  $R_{OUT1}$  limits the current into the FB pin. The  $V_{EAL}$  clamp detects a static OVP fault and the drive is disabled.
3. **FPP Protection:** The FB pin is floating. The internal pulldown resistor  $R_{FB}$  pulls down the FB voltage below the UVP threshold. The UVP comparator detects a UVP fault and the drive is disabled.

UVP and OVP protect the system from low bulk voltages and rapid operating point changes respectively, while the FPP protects the system against floating feedback pin conditions. If FPP is not implemented and a manufacturing error causes the feedback pin to float, then the feedback voltage is dependent on the coupling within the system and the surrounding environment. The coupled feedback voltage may be within the regulation limits (i.e. above the UVP threshold, but below  $V_{REF}$ ) and cause the controller to deliver excessive power. The result is that the output voltage rises until a component fails due to the voltage stress.

The tradeoff for including FPP is that the value of  $R_{FB}$  causes an error in the output voltage. The output voltage including the error caused by  $R_{FB}$  ( $\overline{V_{OUT}}$ ) is calculated using Equation 16:

$$\overline{V_{OUT}} = V_{OUT} + R_{OUT1} \cdot \frac{V_{REF}}{R_{FB}} \quad (\text{eq. 16})$$

Using the values from the OVP calculation, the output voltage including the error caused by  $R_{FB}$  is equal to:

$$\overline{V_{OUT}} = 400 + 4 \text{ M} \cdot \frac{2.5}{4.7 \text{ M}} = 402 \text{ V}$$

The error caused by  $R_{FB}$  is compensated by adjusting  $R_{OUT2}$ . The parallel combination of  $R_{FB}$  and  $R_{OUT2}$  form an equivalent resistor  $R_{EQ}$  that is calculated using Equation 17.

$$R_{EQ} = R_{OUT1} \cdot \frac{V_{REF}}{V_{OUT} - V_{REF}} \quad (\text{eq. 17})$$

$$R_{EQ} = 4 \text{ M} \cdot \frac{2.5}{400 - 2.5} = 25.16 \text{ k}\Omega$$

$R_{EQ}$  is used to calculate  $R_{OUT2}$ .

$$R_{OUT2} = \frac{R_{EQ} \cdot R_{FB}}{R_{FB} - R_{EQ}} \quad (\text{eq. 18})$$

$$R_{OUT2} = \frac{25.16 \text{ k} \cdot 4.7 \text{ M}}{4.7 \text{ M} - 25.16 \text{ k}} = 25.29 \text{ k}\Omega$$

The compensated output voltage is calculated using Equation 19.

$$V_{OUT} = V_{REF} \cdot \left( \frac{R_{OUT1} + R_{OUT2}}{R_{OUT2}} \right) + R_{OUT1} \cdot \frac{V_{REF}}{R_{FB}} \quad (\text{eq. 19})$$

$$V_{OUT} = 2.5 \cdot \left( \frac{4 \text{ M} + 25.29 \text{ k}}{25.29 \text{ k}} \right) + 4 \text{ M} \cdot \frac{2.5}{4.7 \text{ M}} = 400 \text{ V}$$

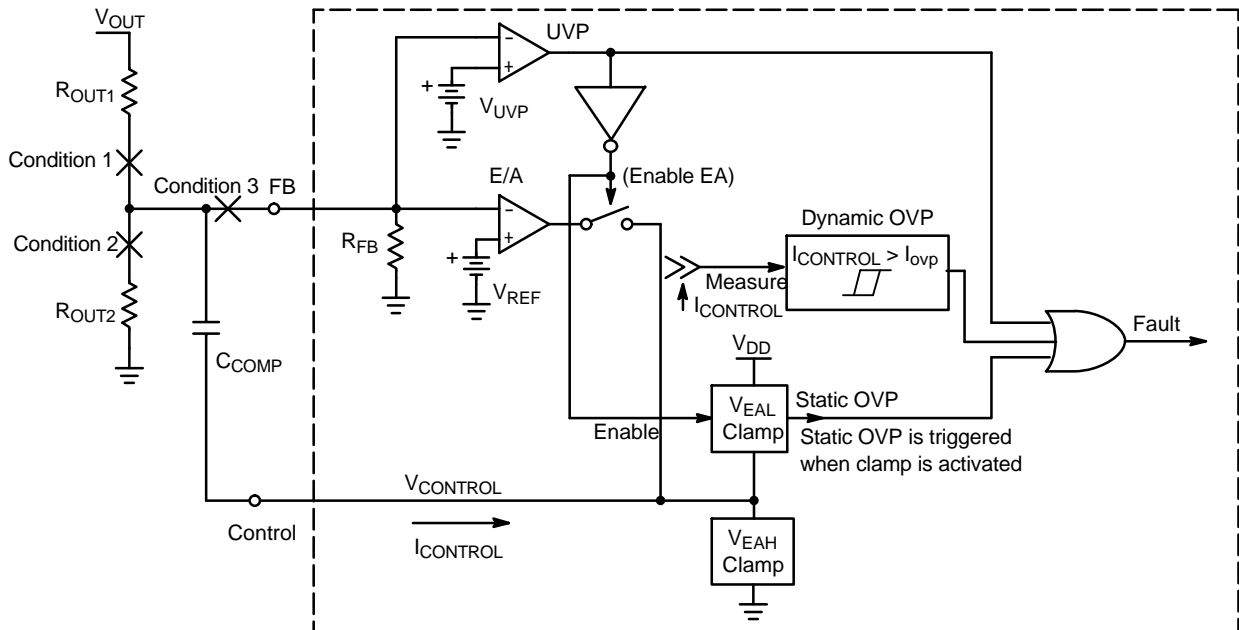

Figure 37. Open Feedback Loop Protection

**Overcurrent Protection (OCP)**

A dedicated pin on the NCP1607 senses the peak current and limits the driver on time if this current exceeds  $V_{CS(limit)}$ . This level is 0.5 V (typical). Therefore, the maximum peak current can be adjusted by changing  $R_{SENSE}$  according to:

$$I_{peak} = \frac{V_{CS(limit)}}{R_S} \quad (\text{eq. 20})$$

An internal LEB filter (Figure 38) reduces the likelihood of switching noise falsely triggering the OCP limit. This filter blanks out the first 250 ns (typical) of the current sense signal. If additional filtering is necessary, a small RC filter can be added between  $R_{SENSE}$  and the CS pin.

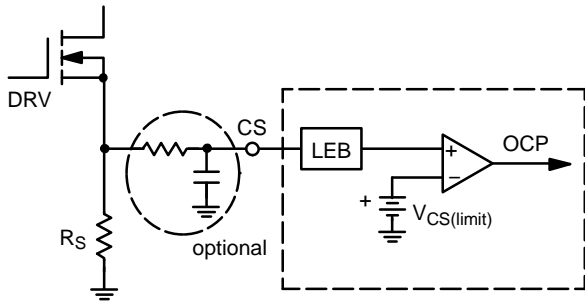

Figure 38. OCP Circuitry with Optional External RC Filter

**SHUTDOWN MODE**

The NCP1607 allows for two methods to place the controller into a standby mode of operation. The FB pin can be pulled below the UVP level (300 mV typical) or the ZCD pin can be pulled below the  $V_{SDL}$  level (200 mV typical). If the FB pin is used for shutdown (Figure 39(a)), care must be taken to ensure that no significant leakage current exists on the shutdown circuitry. This could impact the output voltage regulation. If the ZCD pin is used for shutdown (Figure 39(b)), then any parasitic capacitance created by the shutdown circuitry will add to the delay in detecting the zero inductor current event.

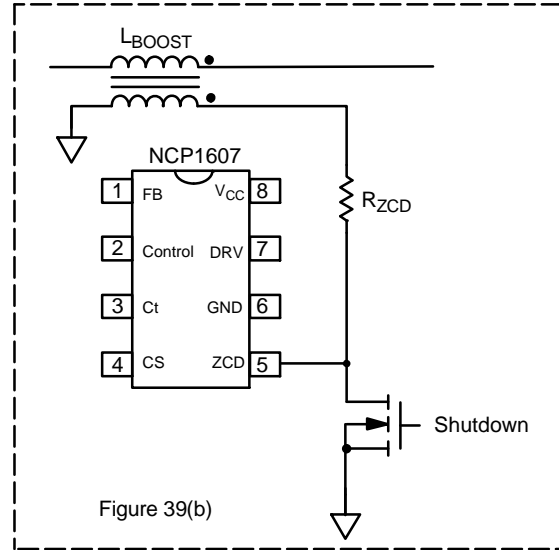
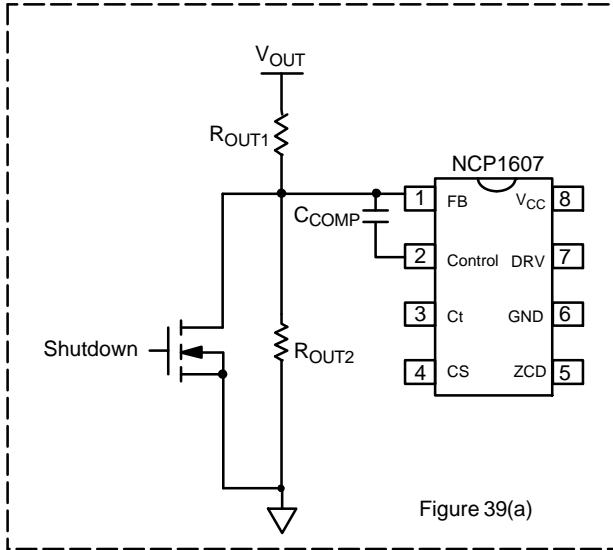

Figure 39. Shutting Down the PFC Stage by Pulling FB to GND (A) or Pulling ZCD to GND (B)

To activate the shutdown feature on ZCD, the internal clamp must first be overcome. This clamp will draw a maximum of  $I_{CL(NEG)}$  (5.0 mA maximum) before releasing and allowing the ZCD pin voltage to drop low enough to shutdown the part (Figure 40). After shutdown, the

comparator includes approximately 90 mV of hysteresis to ensure noise free operation. A small current source (70  $\mu$ A typical) is also activated to pull the unit out of the shutdown condition when the external pull down is released.

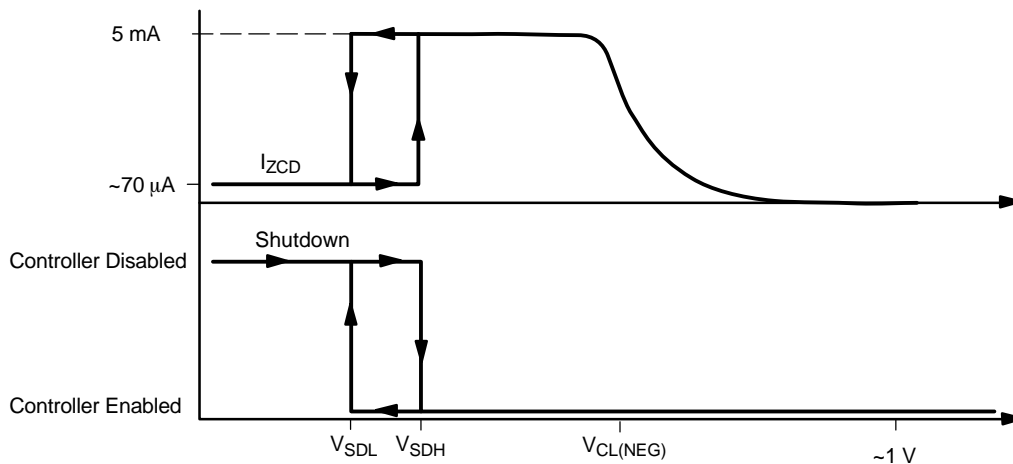

Figure 40. Shutdown Comparator and Current Draw to Overcome Negative Clamp



# NCP1607

## BOOST DESIGN EQUATIONS Components are identified in Figure 1

RMS Input Current	$I_{ac} = \frac{P_{OUT}}{\eta \cdot V_{ac}}$	$\eta$ (the efficiency of only the Boost PFC stage) is generally in the range of 90 – 95%
Maximum Inductor Peak Current	$I_{pk(MAX)} = \frac{2 \cdot \sqrt{2} \cdot P_{OUT}}{\eta \cdot V_{acLL}}$	Where $V_{acLL}$ is the minimum line input voltage. $I_{pk(MAX)}$ occurs at the lowest line voltage.
Inductor Value	$L \leq \frac{2 \cdot V_{ac}^2 \cdot \left( \frac{V_{OUT}}{\sqrt{2}} - V_{ac} \right)}{V_{OUT} \cdot V_{ac} \cdot I_{pk(MAX)} \cdot f_{SW(min)}}$	$f_{SW(MIN)}$ is the minimum desired switching frequency. The maximum L must be calculated at low line and high line.
Maximum On Time	$t_{on(MAX)} = \frac{2 \cdot L \cdot P_{OUT}}{\eta \cdot V_{acLL}^2}$	The maximum on time occurs at the lowest line voltage and maximum output power.
Off Time	$t_{off} = \frac{t_{on}}{\frac{V_{OUT}}{V_{ac} \cdot  \sin(\theta)  \cdot \sqrt{2}} - 1}$	The off time is greatest at the peak of the ac line voltage and approaches zero at the ac line zero crossings. Theta ( $\theta$ ) represents the angle of the ac line voltage.
Frequency	$f_{SW} = \frac{V_{ac}^2 \cdot \eta}{2 \cdot L \cdot P_{OUT}} \cdot \left( 1 - \frac{V_{ac} \cdot  \sin \theta  \cdot \sqrt{2}}{V_{OUT}} \right)$	
Pin 3 Capacitor	$C_t \geq \frac{2 \cdot P_{OUT} \cdot L \cdot I_{CHARGE}}{\eta \cdot V_{ac}^2 \cdot V_{CTMAX}}$	$I_{CHARGE}$ and $V_{CTMAX}$ are given in the NCP1607 specification table.
Boost Turns to ZCD Turns Ratio	$N_B : N_{ZCD} \leq \frac{V_{OUT} - V_{acHL} \cdot \sqrt{2}}{V_{ZCDH}}$	Where $V_{acHL}$ is the maximum line input voltage. The turns ratio must be low enough so as to trigger the ZCD comparators at high line.
Resistor from ZCD winding to the ZCD pin (pin 5)	$R_{ZCD} \geq \frac{V_{acHL} \cdot \sqrt{2}}{I_{CL(NEG)} \cdot (N_B : N_{ZCD})}$	$R_{ZCD}$ must be large enough so that the shutdown comparator is not inadvertently activated.
Boost Output Voltage	$V_{OUT} = V_{REF} \cdot \frac{R_{OUT1} + R_{EQ}}{R_{EQ}}$ $R_{EQ} = \frac{R_{OUT2} \cdot R_{FB}}{R_{OUT2} + R_{FB}}$	
Maximum $V_{OUT}$ voltage prior to OVP activation and the necessary $R_{OUT1}$ and $R_{OUT2}$ .	$V_{OUT(OVP)} = V_{OUT} + (I_{OVP} \cdot R_{OUT1})$ $R_{OUT1} = \frac{V_{OUT(OVP)} - V_{OUT}}{I_{OVP}}$ $R_{EQ} = R_{OUT1} \cdot \frac{V_{REF}}{V_{OUT} - V_{REF}}$ $R_{OUT2} = \frac{R_{EQ} + R_{FB}}{R_{FB} - R_{EQ}}$	$I_{OVP}$ is given in the NCP1607 specification table.
Minimum output voltage necessary to exit under-voltage protection (UVP)	$V_{OUT(UVP)} = V_{UVP} \cdot \frac{R_{OUT1} + R_{EQ}}{R_{EQ}}$	$V_{UVP}$ is given in the NCP1607 specification table.
Bulk Cap Ripple	$V_{ripple(pk-pk)} = \frac{P_{OUT}}{C_{BULK} \cdot 2 \cdot \pi \cdot f_{line} \cdot V_{OUT}}$	Use $f_{line} = 47$ Hz for worst case at universal lines. The ripple must not exceed the OVP level for $V_{OUT}$ .
Inductor RMS Current	$I_{L(RMS)} = \frac{2 \cdot P_{OUT}}{\sqrt{3} \cdot V_{acLL} \cdot \eta}$	
Boost Diode RMS Current	$I_{D(RMS)MAX} = \frac{4}{3} \cdot \sqrt{\frac{2 \cdot \sqrt{2}}{\pi}} \cdot \frac{P_{OUT}}{\eta \cdot \sqrt{V_{acLL} \cdot V_{OUT}}}$	

# NCP1607

## BOOST DESIGN EQUATIONS Components are identified in Figure 1

MOSFET RMS Current	$I_{M(RMS)MAX} = \frac{2}{\sqrt{3}} \cdot \frac{P_{out}}{\eta \cdot Vac_{LL}} \cdot \sqrt{1 - \left( \frac{8 \cdot \sqrt{2} \cdot Vac_{LL}}{3 \pi \cdot V_{out}} \right)}$	
MOSFET Sense Resistor	$R_S = \frac{V_{CS(limit)}}{I_{pk(MAX)}}$ $P_{RS} = I_{M(RMS)}^2 \cdot R_S$	$V_{CS(limit)}$ is given in the NCP1607 specification table.
Bulk Capacitor RMS Current	$I_{C(RMS)} = \sqrt{\frac{32 \cdot \sqrt{2} \cdot P_{OUT}^2}{9 \cdot \pi \cdot Vac_{LL} \cdot V_{OUT} \cdot \eta^2} - (I_{LOAD(RMS)})^2}$	
Type 1 $C_{COMP}$	$C_{COMP} = \frac{10^{G/20}}{4 \cdot \pi \cdot f_{line} \cdot R_{OUT1}}$	G is the desired attenuation in decibels (dB). Typically it is 60 dB.

# MECHANICAL CASE OUTLINE PACKAGE DIMENSIONS

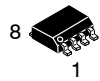

SCALE 1:1

SOIC-8 NB  
CASE 751-07  
ISSUE AK

DATE 16 FEB 2011

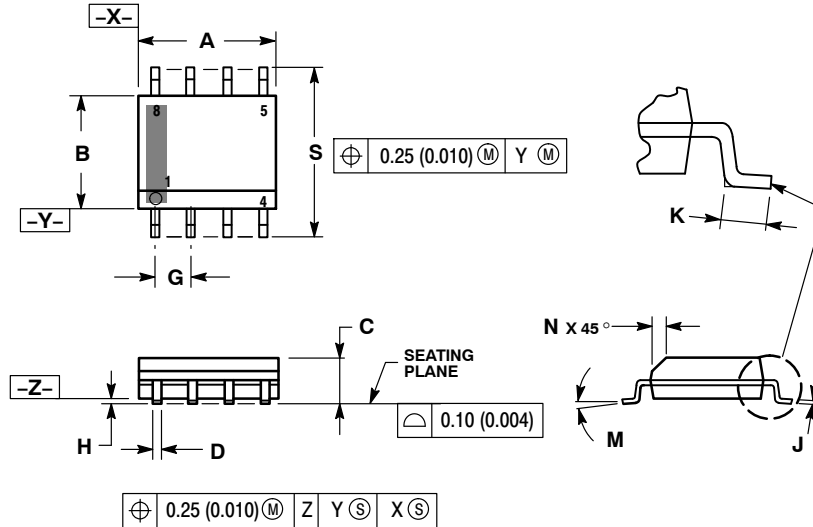

- NOTES:
1. DIMENSIONING AND TOLERANCING PER ANSI Y14.5M, 1982.
  2. CONTROLLING DIMENSION: MILLIMETER.
  3. DIMENSION A AND B DO NOT INCLUDE MOLD PROTRUSION.
  4. MAXIMUM MOLD PROTRUSION 0.15 (0.006) PER SIDE.
  5. DIMENSION D DOES NOT INCLUDE DAMBAR PROTRUSION. ALLOWABLE DAMBAR PROTRUSION SHALL BE 0.127 (0.005) TOTAL IN EXCESS OF THE D DIMENSION AT MAXIMUM MATERIAL CONDITION.
  6. 751-01 THRU 751-06 ARE OBSOLETE. NEW STANDARD IS 751-07.

DIM	MILLIMETERS		INCHES	
	MIN	MAX	MIN	MAX
A	4.80	5.00	0.189	0.197
B	3.80	4.00	0.150	0.157
C	1.35	1.75	0.053	0.069
D	0.33	0.51	0.013	0.020
G	1.27 BSC		0.050 BSC	
H	0.10	0.25	0.004	0.010
J	0.19	0.25	0.007	0.010
K	0.40	1.27	0.016	0.050
M	0°	8°	0°	8°
N	0.25	0.50	0.010	0.020
S	5.80	6.20	0.228	0.244

## GENERIC MARKING DIAGRAM\*

### SOLDERING FOOTPRINT\*

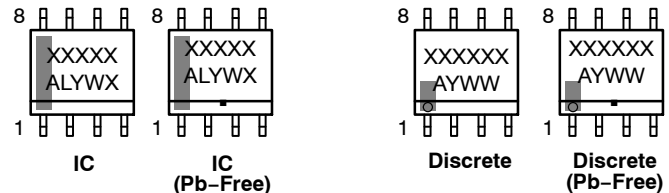
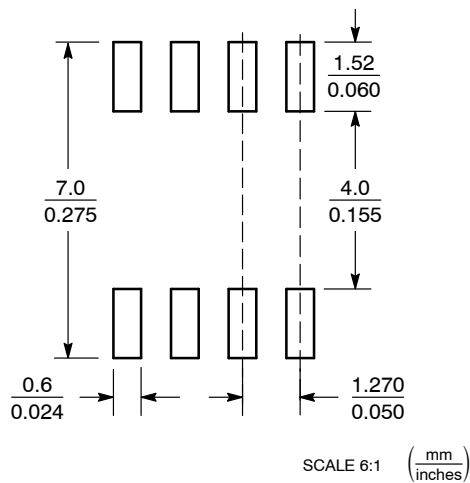

XXXXXX = Specific Device Code  
A = Assembly Location  
L = Wafer Lot  
Y = Year  
W = Work Week  
▪ = Pb-Free Package

XXXXXX = Specific Device Code  
A = Assembly Location  
Y = Year  
WW = Work Week  
▪ = Pb-Free Package

\*This information is generic. Please refer to device data sheet for actual part marking. Pb-Free indicator, "G" or microdot "▪", may or may not be present. Some products may not follow the Generic Marking.

\*For additional information on our Pb-Free strategy and soldering details, please download the ON Semiconductor Soldering and Mounting Techniques Reference Manual, SOLDERRM/D.

## STYLES ON PAGE 2

DOCUMENT NUMBER:	98ASB42564B	Electronic versions are uncontrolled except when accessed directly from the Document Repository. Printed versions are uncontrolled except when stamped "CONTROLLED COPY" in red.
DESCRIPTION:	SOIC-8 NB	PAGE 1 OF 2

onsemi and ONsemi are trademarks of Semiconductor Components Industries, LLC dba onsemi or its subsidiaries in the United States and/or other countries. onsemi reserves the right to make changes without further notice to any products herein. onsemi makes no warranty, representation or guarantee regarding the suitability of its products for any particular purpose, nor does onsemi assume any liability arising out of the application or use of any product or circuit, and specifically disclaims any and all liability, including without limitation special, consequential or incidental damages. onsemi does not convey any license under its patent rights nor the rights of others.

**SOIC-8 NB**  
**CASE 751-07**  
**ISSUE AK**

DATE 16 FEB 2011

- |   |  |  |  |
|---|--|--|--|
| <p>STYLE 1:<br/>         PIN 1. EMITTER<br/>         2. COLLECTOR<br/>         3. COLLECTOR<br/>         4. EMITTER<br/>         5. EMITTER<br/>         6. BASE<br/>         7. BASE<br/>         8. EMITTER</p>   | <p>STYLE 2:<br/>         PIN 1. COLLECTOR, DIE, #1<br/>         2. COLLECTOR, #1<br/>         3. COLLECTOR, #2<br/>         4. COLLECTOR, #2<br/>         5. BASE, #2<br/>         6. EMITTER, #2<br/>         7. BASE, #1<br/>         8. EMITTER, #1</p>               | <p>STYLE 3:<br/>         PIN 1. DRAIN, DIE #1<br/>         2. DRAIN, #1<br/>         3. DRAIN, #2<br/>         4. DRAIN, #2<br/>         5. GATE, #2<br/>         6. SOURCE, #2<br/>         7. GATE, #1<br/>         8. SOURCE, #1</p>                            | <p>STYLE 4:<br/>         PIN 1. ANODE<br/>         2. ANODE<br/>         3. ANODE<br/>         4. ANODE<br/>         5. ANODE<br/>         6. ANODE<br/>         7. ANODE<br/>         8. COMMON CATHODE</p>   |
| <p>STYLE 5:<br/>         PIN 1. DRAIN<br/>         2. DRAIN<br/>         3. DRAIN<br/>         4. DRAIN<br/>         5. GATE<br/>         6. GATE<br/>         7. SOURCE<br/>         8. SOURCE</p>   | <p>STYLE 6:<br/>         PIN 1. SOURCE<br/>         2. DRAIN<br/>         3. DRAIN<br/>         4. SOURCE<br/>         5. SOURCE<br/>         6. GATE<br/>         7. GATE<br/>         8. SOURCE</p>  | <p>STYLE 7:<br/>         PIN 1. INPUT<br/>         2. EXTERNAL BYPASS<br/>         3. THIRD STAGE SOURCE<br/>         4. GROUND<br/>         5. DRAIN<br/>         6. GATE 3<br/>         7. SECOND STAGE Vd<br/>         8. FIRST STAGE Vd</p>                    | <p>STYLE 8:<br/>         PIN 1. COLLECTOR, DIE #1<br/>         2. BASE, #1<br/>         3. BASE, #2<br/>         4. COLLECTOR, #2<br/>         5. COLLECTOR, #2<br/>         6. EMITTER, #2<br/>         7. EMITTER, #1<br/>         8. COLLECTOR, #1</p>                              |
| <p>STYLE 9:<br/>         PIN 1. EMITTER, COMMON<br/>         2. COLLECTOR, DIE #1<br/>         3. COLLECTOR, DIE #2<br/>         4. EMITTER, COMMON<br/>         5. EMITTER, COMMON<br/>         6. BASE, DIE #2<br/>         7. BASE, DIE #1<br/>         8. EMITTER, COMMON</p> | <p>STYLE 10:<br/>         PIN 1. GROUND<br/>         2. BIAS 1<br/>         3. OUTPUT<br/>         4. GROUND<br/>         5. GROUND<br/>         6. BIAS 2<br/>         7. INPUT<br/>         8. GROUND</p>  | <p>STYLE 11:<br/>         PIN 1. SOURCE 1<br/>         2. GATE 1<br/>         3. SOURCE 2<br/>         4. GATE 2<br/>         5. DRAIN 2<br/>         6. DRAIN 2<br/>         7. DRAIN 1<br/>         8. DRAIN 1</p>   | <p>STYLE 12:<br/>         PIN 1. SOURCE<br/>         2. SOURCE<br/>         3. SOURCE<br/>         4. GATE<br/>         5. DRAIN<br/>         6. DRAIN<br/>         7. DRAIN<br/>         8. DRAIN</p>   |
| <p>STYLE 13:<br/>         PIN 1. N.C.<br/>         2. SOURCE<br/>         3. SOURCE<br/>         4. GATE<br/>         5. DRAIN<br/>         6. DRAIN<br/>         7. DRAIN<br/>         8. DRAIN</p>  | <p>STYLE 14:<br/>         PIN 1. N-SOURCE<br/>         2. N-GATE<br/>         3. P-SOURCE<br/>         4. P-GATE<br/>         5. P-DRAIN<br/>         6. P-DRAIN<br/>         7. N-DRAIN<br/>         8. N-DRAIN</p>   | <p>STYLE 15:<br/>         PIN 1. ANODE 1<br/>         2. ANODE 1<br/>         3. ANODE 1<br/>         4. ANODE 1<br/>         5. CATHODE, COMMON<br/>         6. CATHODE, COMMON<br/>         7. CATHODE, COMMON<br/>         8. CATHODE, COMMON</p>               | <p>STYLE 16:<br/>         PIN 1. EMITTER, DIE #1<br/>         2. BASE, DIE #1<br/>         3. EMITTER, DIE #2<br/>         4. BASE, DIE #2<br/>         5. COLLECTOR, DIE #2<br/>         6. COLLECTOR, DIE #2<br/>         7. COLLECTOR, DIE #1<br/>         8. COLLECTOR, DIE #1</p> |
| <p>STYLE 17:<br/>         PIN 1. VCC<br/>         2. V2OUT<br/>         3. V1OUT<br/>         4. TXE<br/>         5. RXE<br/>         6. VEE<br/>         7. GND<br/>         8. ACC</p>  | <p>STYLE 18:<br/>         PIN 1. ANODE<br/>         2. ANODE<br/>         3. SOURCE<br/>         4. GATE<br/>         5. DRAIN<br/>         6. DRAIN<br/>         7. CATHODE<br/>         8. CATHODE</p>   | <p>STYLE 19:<br/>         PIN 1. SOURCE 1<br/>         2. GATE 1<br/>         3. SOURCE 2<br/>         4. GATE 2<br/>         5. DRAIN 2<br/>         6. MIRROR 2<br/>         7. DRAIN 1<br/>         8. MIRROR 1</p>   | <p>STYLE 20:<br/>         PIN 1. SOURCE (N)<br/>         2. GATE (N)<br/>         3. SOURCE (P)<br/>         4. GATE (P)<br/>         5. DRAIN<br/>         6. DRAIN<br/>         7. DRAIN<br/>         8. DRAIN</p>   |
| <p>STYLE 21:<br/>         PIN 1. CATHODE 1<br/>         2. CATHODE 2<br/>         3. CATHODE 3<br/>         4. CATHODE 4<br/>         5. CATHODE 5<br/>         6. COMMON ANODE<br/>         7. COMMON ANODE<br/>         8. CATHODE 6</p>  | <p>STYLE 22:<br/>         PIN 1. I/O LINE 1<br/>         2. COMMON CATHODE/VCC<br/>         3. COMMON CATHODE/VCC<br/>         4. I/O LINE 3<br/>         5. COMMON ANODE/GND<br/>         6. I/O LINE 4<br/>         7. I/O LINE 5<br/>         8. COMMON ANODE/GND</p> | <p>STYLE 23:<br/>         PIN 1. LINE 1 IN<br/>         2. COMMON ANODE/GND<br/>         3. COMMON ANODE/GND<br/>         4. LINE 2 IN<br/>         5. LINE 2 OUT<br/>         6. COMMON ANODE/GND<br/>         7. COMMON ANODE/GND<br/>         8. LINE 1 OUT</p> | <p>STYLE 24:<br/>         PIN 1. BASE<br/>         2. EMITTER<br/>         3. COLLECTOR/ANODE<br/>         4. COLLECTOR/ANODE<br/>         5. CATHODE<br/>         6. CATHODE<br/>         7. COLLECTOR/ANODE<br/>         8. COLLECTOR/ANODE</p>                                      |
| <p>STYLE 25:<br/>         PIN 1. VIN<br/>         2. N/C<br/>         3. REXT<br/>         4. GND<br/>         5. IOUT<br/>         6. IOUT<br/>         7. IOUT<br/>         8. IOUT</p>   | <p>STYLE 26:<br/>         PIN 1. GND<br/>         2. dv/dt<br/>         3. ENABLE<br/>         4. ILIMIT<br/>         5. SOURCE<br/>         6. SOURCE<br/>         7. SOURCE<br/>         8. VCC</p>  | <p>STYLE 27:<br/>         PIN 1. ILIMIT<br/>         2. OVLO<br/>         3. UVLO<br/>         4. INPUT+<br/>         5. SOURCE<br/>         6. SOURCE<br/>         7. SOURCE<br/>         8. DRAIN</p>  | <p>STYLE 28:<br/>         PIN 1. SW_TO_GND<br/>         2. DASIC_OFF<br/>         3. DASIC_SW_DET<br/>         4. GND<br/>         5. V_MON<br/>         6. VBULK<br/>         7. VBULK<br/>         8. VIN</p>  |
| <p>STYLE 29:<br/>         PIN 1. BASE, DIE #1<br/>         2. EMITTER, #1<br/>         3. BASE, #2<br/>         4. EMITTER, #2<br/>         5. COLLECTOR, #2<br/>         6. COLLECTOR, #2<br/>         7. COLLECTOR, #1<br/>         8. COLLECTOR, #1</p>                        | <p>STYLE 30:<br/>         PIN 1. DRAIN 1<br/>         2. DRAIN 1<br/>         3. GATE 2<br/>         4. SOURCE 2<br/>         5. SOURCE 1/DRAIN 2<br/>         6. SOURCE 1/DRAIN 2<br/>         7. SOURCE 1/DRAIN 2<br/>         8. GATE 1</p>                           |  |  |

<b>DOCUMENT NUMBER:</b>	<b>98ASB42564B</b>	Electronic versions are uncontrolled except when accessed directly from the Document Repository. Printed versions are uncontrolled except when stamped "CONTROLLED COPY" in red.
<b>DESCRIPTION:</b>	<b>SOIC-8 NB</b>	<b>PAGE 2 OF 2</b>

**onsemi** and **ONSEMI** are trademarks of Semiconductor Components Industries, LLC dba **onsemi** or its subsidiaries in the United States and/or other countries. **onsemi** reserves the right to make changes without further notice to any products herein. **onsemi** makes no warranty, representation or guarantee regarding the suitability of its products for any particular purpose, nor does **onsemi** assume any liability arising out of the application or use of any product or circuit, and specifically disclaims any and all liability, including without limitation special, consequential or incidental damages. **onsemi** does not convey any license under its patent rights nor the rights of others.

**onsemi**, **Onsemi**, and other names, marks, and brands are registered and/or common law trademarks of Semiconductor Components Industries, LLC dba "**onsemi**" or its affiliates and/or subsidiaries in the United States and/or other countries. **onsemi** owns the rights to a number of patents, trademarks, copyrights, trade secrets, and other intellectual property. A listing of **onsemi**'s product/patent coverage may be accessed at [www.onsemi.com/site/pdf/Patent-Marking.pdf](http://www.onsemi.com/site/pdf/Patent-Marking.pdf). **onsemi** reserves the right to make changes at any time to any products or information herein, without notice. The information herein is provided "as-is" and **onsemi** makes no warranty, representation or guarantee regarding the accuracy of the information, product features, availability, functionality, or suitability of its products for any particular purpose, nor does **onsemi** assume any liability arising out of the application or use of any product or circuit, and specifically disclaims any and all liability, including without limitation special, consequential or incidental damages. Buyer is responsible for its products and applications using **onsemi** products, including compliance with all laws, regulations and safety requirements or standards, regardless of any support or applications information provided by **onsemi**. "Typical" parameters which may be provided in **onsemi** data sheets and/or specifications can and do vary in different applications and actual performance may vary over time. All operating parameters, including "Typicals" must be validated for each customer application by customer's technical experts. **onsemi** does not convey any license under any of its intellectual property rights nor the rights of others. **onsemi** products are not designed, intended, or authorized for use as a critical component in life support systems or any FDA Class 3 medical devices or medical devices with a same or similar classification in a foreign jurisdiction or any devices intended for implantation in the human body. Should Buyer purchase or use **onsemi** products for any such unintended or unauthorized application, Buyer shall indemnify and hold **onsemi** and its officers, employees, subsidiaries, affiliates, and distributors harmless against all claims, costs, damages, and expenses, and reasonable attorney fees arising out of, directly or indirectly, any claim of personal injury or death associated with such unintended or unauthorized use, even if such claim alleges that **onsemi** was negligent regarding the design or manufacture of the part. **onsemi** is an Equal Opportunity/Affirmative Action Employer. This literature is subject to all applicable copyright laws and is not for resale in any manner.

## ADDITIONAL INFORMATION

### TECHNICAL PUBLICATIONS:



Technical Library: [www.onsemi.com/design/resources/technical-documentation](http://www.onsemi.com/design/resources/technical-documentation)  
onsemi Website: [www.onsemi.com](http://www.onsemi.com)

### ONLINE SUPPORT: [www.onsemi.com/support](http://www.onsemi.com/support)

For additional information, please contact your local Sales Representative at [www.onsemi.com/support/sales](http://www.onsemi.com/support/sales)

## Looking for pricing, stock, or lifecycle information?

Click below to explore more details on WIN SOURCE:

-  [View NCP1607BDR2G on WIN SOURCE](#)
-  [ON Semiconductor](#) Information

## Optimize Your Supply Chain with WIN SOURCE Solutions

-  Global Sourcing Solution
-  Obsolete Management
-  Cost Control Management
-  Shortage Management
-  Alternative Solution
-  Excess Inventory Management