



**THE DATASHEET OF  
NCN8024DWR2G**



# Smart Card Interface IC

## NCN8024

The NCN8024 is a single smart card interface IC. It is dedicated for 3.0 V/5.0 V smart card reader/writer applications.

The device is fully compatible with the ISO 7816-3 and EMV standards as well as with standards specifying conditional access in Set-Top-Box (STB) including NDS.

For details regarding device implementation refer to application note AND8452/D, available upon request (please contact your local onsemi sales office or representative).

### Features

- Single IC Card Interface
- Fully Compatible with ISO 7816-3, EMV and Related Standards Including NDS
- Three Bidirectional Buffered I/O Level Shifters (C4, C7 and C8 Card Pins)
- 3.0 V or 5.0 V  $\pm 5\%$  Regulated Card Power Supply such as  $I_{CC} \leq 75$  mA at  $3.3$  V  $\leq V_{DDP} \leq 5.5$  V
- Independent Power Supply Range on Controller Interface ( $2.7$  V  $< V_{DD} < 5.5$  V)
- Handles 3.0 V and 5.0 V Smart Cards
- Thermal and Short Circuit Protection on all Card Pins
- Support up to 18 MHz Clock with Internal Division Ratio 1/1, 1/2, 1/4 and 1/8 through CLKDIV1 and CLKDIV2 Pins
- ESD Protection on Card Pins up to 8 kV+ (Human Body Model)
- Activation/Deactivation Sequences (ISO7816)
- Fault Protection Mechanisms Enabling Automatic Device Deactivation in Case of Overload, Overheating, Card Take-off or Power Supply Drop-out
- Interrupt Signal  $\overline{INT}$  for Card Presence and Faults
- External Undervoltage Lockout Threshold Adjustment on  $V_{DD}$  (PORADJ Pin)
- Available in 2 Package Formats: SOIC-28 and TSSOP-28
- These are Pb-Free Devices

### Typical Application

- Set-Top Boxes Conditional Access & Pay-TV
- Conditional Access Modules (CAM)
- POS / ATM
- Access Control, Identification

### MARKING DIAGRAMS

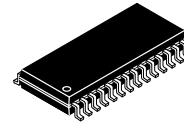

SOIC-28  
CASE 751F

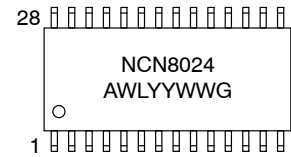

TSSOP-28  
CASE 948AA

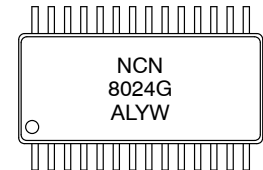

NCN8024 = Specific Device Code  
 A = Assembly Location  
 WL, L = Wafer Lot  
 YY, Y = Year  
 WW, W = Work Week  
 G = Pb-Free Package

### ORDERING INFORMATION

See detailed ordering and shipping information on page 14 of this data sheet.

# NCN8024

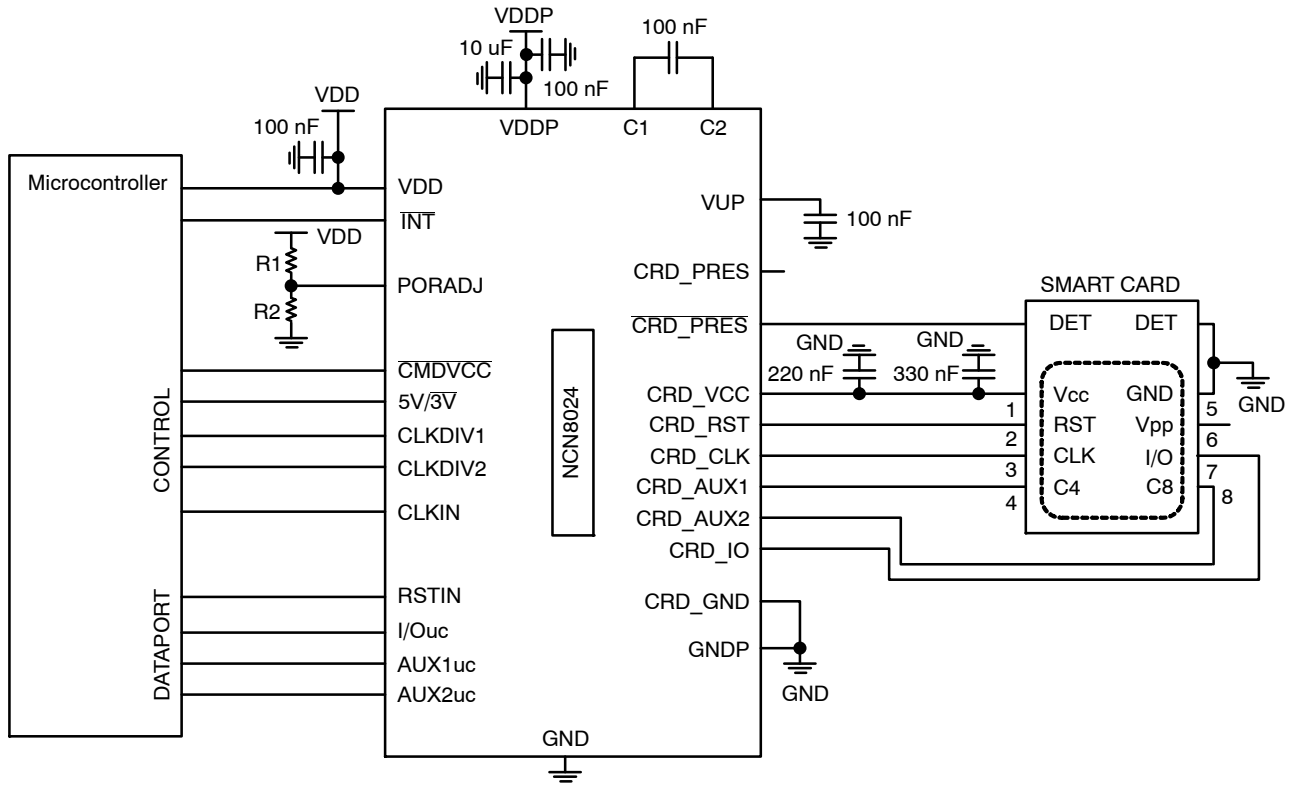

Figure 1. Typical Smart Card Interface Application

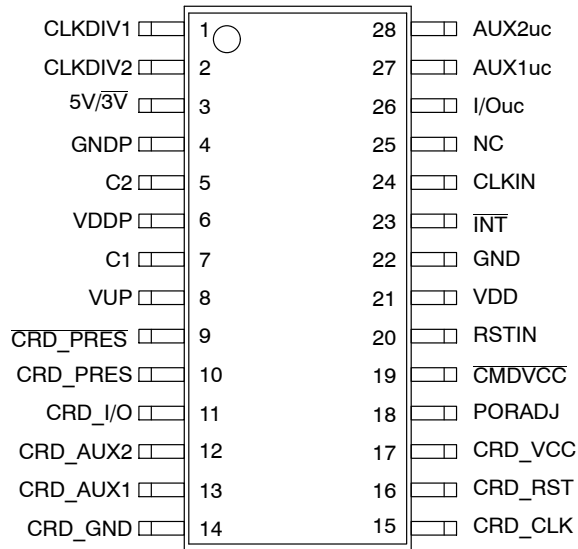
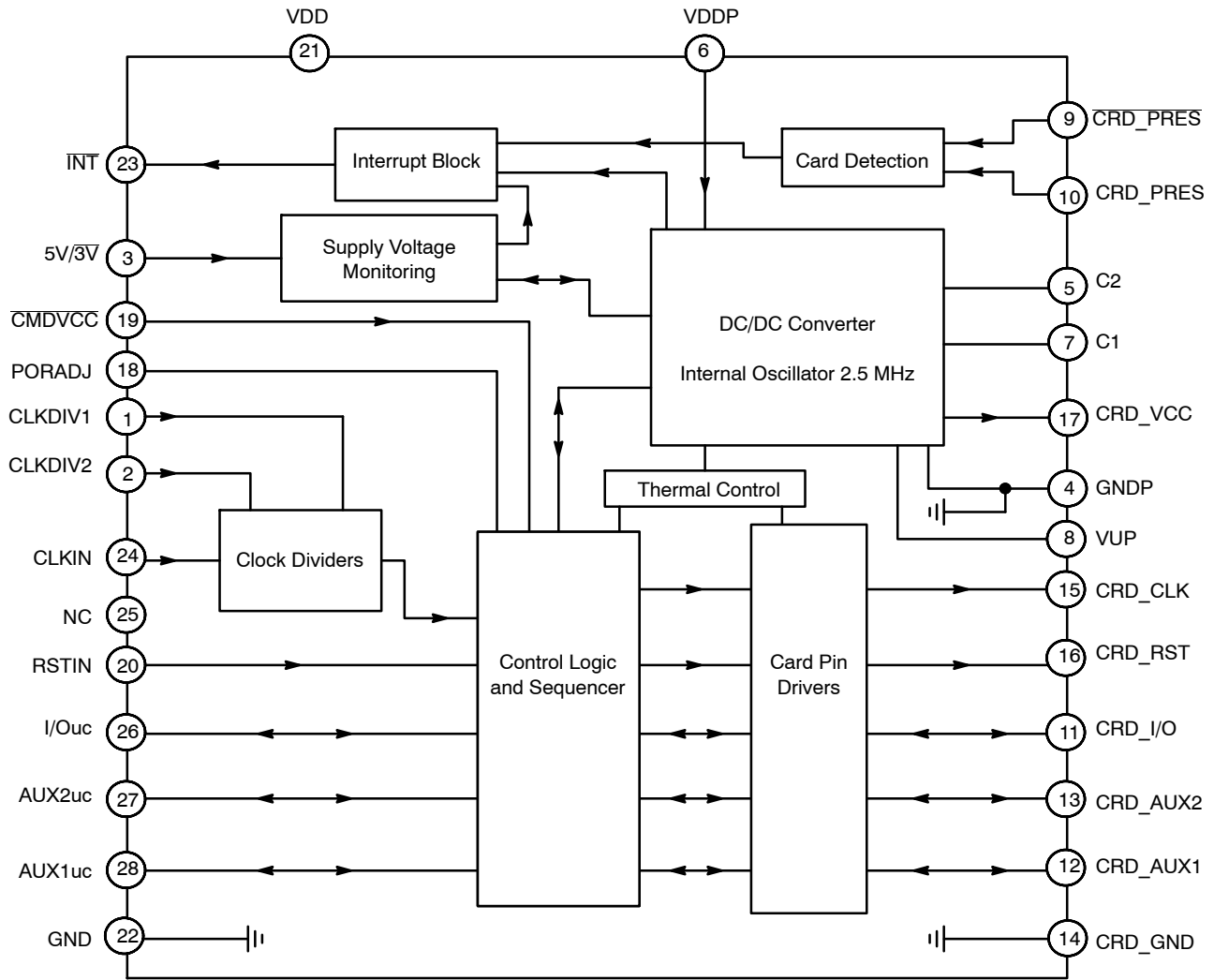

Figure 2. SOIC-28 and TSSOP-28 Pinout (Top View)

# NCN8024



**Figure 3. NCN8024 Block Diagram**

## PIN FUNCTION AND DESCRIPTION

Pin #	Name	Type	Description
1	CLKDIV1	Input	This pin coupled with CLKDIV2 is used to program the clock frequency division ratio (Table 1).
2	CLKDIV2	Input	This pin coupled with CLKDIV1 is used to program the clock frequency division ratio (Table 1).
3	5V/3V	Input	Allows selecting card V <sub>CC</sub> power supply voltage. CRD_V <sub>CC</sub> = 5 V when 5V/3V = HIGH or 3 V when 5V/3V = LOW
4	GNDP	GND	DC/DC Converter Power Supply Ground
5	C2	Power	DC/DC Converter Capacitor pin number 2 – A 100 nF capacitor is connected between this pin and pin C1. The capacitor has to feature an ESR lower than 100 mΩ
6	VDDP	Power	DC/DC Converter Power Supply Voltage
7	C1	Power	DC/DC Converter Capacitor pin number 1 – A 100 nF capacitor is connected between this pin and pin C2. The capacitor has to feature an ESR lower than 100 mΩ
8	VUP	Power	Charge-pump output – a very low ESR 100 nF capacitor (ESR < 100 mΩ) is connected between this pin and GNDP
9	CRD_PRES	Input	Card presence pin active (card present) when CRD_PRES = Low. A built-in debounce timer of about 8 ms is activated when a card is inserted.
10	CRD_PRES	Input	Card presence pin active (card present) when CRD_PRES = High. A built-in debounce timer of about 8 ms is activated when a card is inserted.

# NCN8024

## PIN FUNCTION AND DESCRIPTION

Pin #	Name	Type	Description
11	CRD_I/O	Input/Output	This pin handles the connection to the serial I/O (C7) of the card connector. A bi-directional level translator adapts the serial I/O signal between the card and the micro controller. An 11 k $\Omega$ (typical) pullup resistor to CRD_VCC provides a High impedance state for the smart card I/O link.
12	CRD_AUX2	Input/Output	This pin handles the connection to the chip card's serial auxiliary AUX2 I/O pin (C8). A bi-directional level translator adapts the serial I/O signal between the card and the micro controller. An 11 k $\Omega$ (typical) pullup resistor to CRD_VCC provides a High impedance state for the smart card C8 pin.
13	CRD_AUX1	Input/Output	This pin handles the connection to the chip card's serial auxiliary AUX1 I/O pin (C4). A bi-directional level translator adapts the serial I/O signal between the card and the micro controller. An 11 k $\Omega$ (typical) pullup resistor to CRD_VCC provides a High impedance state for the smart card C4 pin.
14	CRD_GND	GND	Card Ground
15	CRD_CLK	Output	This pin is connected to the CLOCK card connector's pin (Chip card's pin C3). The Clock signal comes from the CLKIN input through clock dividers and level shifter.
16	CRD_RST	Output	This pin is connected to the chip card's RESET pin (C2) through the card connector. A level translator adapts the external Reset (RSTIN) signal to the smart card.
17	CRD_VCC	Power	This pin is connected to the smart card power supply pin. An internal DC/DC converter is programmable using the pin 5V/3V to supply either 5 V or 3 V output voltage. An external distributed ceramic capacitor (200 nF + 330 nF typical recommended) must be connected across CRD_VCC and CRD_GND. This set of capacitor (if distributed) must be low ESR (< 100 m $\Omega$ ).
18	PORADJ	Input	Power-on reset threshold adjustment input pin for changing the reset threshold with an external resistor power divider. Recommended to be connected to ground when unused.
19	$\overline{\text{CMDVCC}}$	Input	Command VCC pin. Activation sequence Enable/Disable pin (active Low). The activation sequence is enabled by toggling $\overline{\text{CMDVCC}}$ High to Low and when a card is present.
20	RSTIN	Input	This Reset input connected to the host and referred to VDD (microcontroller side), is connected to the smart card Reset pin through the internal level shifter which translates the level according to the CRD_VCC programmed value.
21	VDD	Power	This pin is connected to the system controller power supply. It configures the level shifter input stage to accept the signals coming from the controller. A 0.1 $\mu$ F capacitor shall be used to bypass the power supply voltage. When VDD is below 2.35 V typical the card pins are disabled.
22	GND	GND	Ground
23	INT	Output	The interrupt request is activated LOW on this pin. This is enabled when a card is present and the card presence is detected by CRD_PRES or $\overline{\text{CRD\_PRES}}$ pins. Similarly an interrupt is generated when CRD_VCC is overloaded. 20 k $\Omega$ typical integrated pullup resistor to VDD.
24	CLKIN	Input	Clock Input for External Clock
25	NC		Unconnected
26	I/Ouc	Input/Output	This pin is connected to an external micro-controller. A bi-directional level translator adapts the serial I/O signal between the smart card and the external controller. A built-in constant 11 k $\Omega$ (typical) resistor provides a high impedance state.
27	AUX1uc	Input/Output	This pin is connected to an external micro-controller. A bi-directional level translator adapts the serial C4 signal between the smart card and the external controller. A built-in constant 11 k $\Omega$ (typical) resistor provides a high impedance state.
28	AUX2uc	Input/Output	This pin is connected to an external micro-controller. A bi-directional level translator adapts the serial C8 signal between the smart card and the external controller. A built-in constant 11 k $\Omega$ (typical) resistor provides a high impedance state.

# NCN8024

## ATTRIBUTES

Characteristics	Values
ESD protection Human Body Model (HBM) (Note 1) Card Pins (Card Interface Pins 9 – 17) All Other Pins Machine Model (MM) Card Pins (Card Interface Pins 9 – 17) All Other Pins	8 kV 2 kV 400 V 150 V
Moisture sensitivity (Note 2) SOIC–28 and TSSOP–28	Level 3
Flammability Rating Oxygen Index: 28 to 34	UL 94 V–0 @ 0.125 in
Meets or exceeds JEDEC Spec EIA/JESD78 IC Latch–up Test	

- Human Body Model (HBM), R = 1500 Ω, C = 100 pF.
- For additional information, see Application Note AND8003/D.

## MAXIMUM RATINGS (Note 3)

Rating	Symbol	Value	Unit
DC/DC Converter Power Supply Voltage	V <sub>DDP</sub>	-0.3 ≤ V <sub>DDP</sub> ≤ 5.5	V
Power Supply from Microcontroller Side	V <sub>DD</sub>	-0.3 ≤ V <sub>DD</sub> ≤ 5.5	V
External Card Power Supply	CRD_V <sub>CC</sub>	-0.3 ≤ CRD_V <sub>CC</sub> ≤ 5.5	V
Charge Pump Output	V <sub>UP</sub>	-0.3 ≤ V <sub>UP</sub> ≤ 5.5	
Digital Input Pins	V <sub>in</sub>	-0.3 ≤ V <sub>in</sub> ≤ V <sub>DD</sub>	V
Digital Output Pins (I/Ouc, AUX1uc, AUX2uc, INT)	V <sub>out</sub>	-0.3 ≤ V <sub>out</sub> ≤ V <sub>DD</sub>	V
Smart Card Output Pins	V <sub>out</sub>	-0.3 ≤ V <sub>out</sub> ≤ CRD_V <sub>CC</sub>	V
Thermal Resistance Junction–to–Air SOIC–28 TSSOP–28	R <sub>θJA</sub>	75 76	°C/W
Operating Ambient Temperature Range	T <sub>A</sub>	-40 to +85	°C
Operating Junction Temperature Range	T <sub>J</sub>	-40 to +125	°C
Maximum Junction Temperature	T <sub>Jmax</sub>	+125	°C
Storage Temperature Range	T <sub>stg</sub>	-65 to + 150	°C

Stresses exceeding those listed in the Maximum Ratings table may damage the device. If any of these limits are exceeded, device functionality should not be assumed, damage may occur and reliability may be affected.

- Maximum electrical ratings are defined as those values beyond which damage to the device may occur at T<sub>A</sub> = +25°C

# NCN8024

## POWER SUPPLY SECTION ( $V_{DD} = 3.3\text{ V}$ ; $V_{DDP} = 5\text{ V}$ ; $T_{amb} = 25^{\circ}\text{C}$ ; $F_{CLKIN} = 10\text{ MHz}$ )

Pin	Symbol	Rating	Min	Typ	Max	Unit
6	$V_{DDP}$	DC/DC Converter Power Supply, $CRD\_V_{CC} = 3\text{ V}$ and $5\text{ V}$ with DC Load Such as $ I_{CC}  \leq 75\text{ mA}$ $ I_{CC}  \leq 20\text{ mA}$	3.3 3.0	5.0	5.5 5.5	V
6	$V_{DDP}$	NDS Conditions: DC/DC Converter Power Supply, $CRD\_V_{CC} = 3\text{ V}$ and $5\text{ V}$ with $75\text{ mA}$ Load Transient from $100\text{ Hz}$ to $200\text{ MHz}$ and /CMDVCC Cycling (Note 4): $ I_{CC}  \leq 75\text{ mA}$ $ I_{CC}  \leq 20\text{ mA}$	4.5 3.15	5.0	5.5 5.5	V
6	$I_{DDP}$	Inactive Mode	–	–	0.3	mA
6	$I_{DDP}$	DC Operating Supply Current, $F_{CLKIN} = 10\text{ MHz}$ , $C_{outCRD\_CLK} = 33\text{ pF}$ , $ I_{CRD\_VCC}  = 0$	–	–	5.0	mA
6	$I_{DDP}$	DC Operating Supply Current, $CRD\_V_{CC} = 5\text{ V}$ , $I_{CRD\_VCC} = 75\text{ mA}$ $CRD\_V_{CC} = 3\text{ V}$ , $I_{CRD\_VCC} = 75\text{ mA}$	–	–	200 200	mA
21	$V_{DD}$	Operating Voltage	2.7	–	5.5	V
21	$I_{VDD}$	Inactive Mode 0 Standby Current	–	–	0.6	mA
21	$I_{VDD}$	Operating Current – $F_{CLK\_IN} = 10\text{ MHz}$ , $C_{outCRD\_CLK} = 33\text{ pF}$ , $ I_{CRD\_VCC}  = 0$	–	–	1	mA
21	$UVLOV_{DD}$	Undervoltage Lockout (UVLO), No External Resistor at Pin PORADJ (Connected to GND), Falling $V_{DD}$ Level	2.25	2.35	2.45	V
21	$UVLOHys$	UVLO Hysteresis, No External Resistor at Pin PORADJ (Connected to GND)	50	130	180	mV

### PORADJ PIN

18	$V_{PORth+}$	External Rising Threshold Voltage on $V_{DD}$ for Power On Reset – Pin PORADJ	1.18	1.24	1.3	V
18	$V_{PORth-}$	External Falling Threshold voltage on $V_{DD}$ for Power On Reset – Pin PORADJ	1.13	1.18	1.24	V
18	$V_{PORHys}$	Hysteresis on $V_{PORth}$ (pin PORADJ)	30	60	100	mV
18	$t_{POR}$	Width of Power-On Reset Pulse (Note 4) No External Resistor on PORADJ External Resistor on PORADJ	4 4	8 8	12 12	ms
18	$I_{IL}$	Low Level Input Leakage Current, $V_{IL} < 0.5\text{ V}$ (Pulldown Current Source)		5		$\mu\text{A}$

### DC/DC CONVERTER

	$F_{CLK}$	DC/DC Converter Clock Frequency when Card Active (Note 4)	2.2		3.2	MHz
8	$V_{UP}$	Output Voltage on pin $V_{UP}$ (average value) $CRD\_V_{CC} = 5\text{ V}$ $CRD\_V_{CC} = 3\text{ V}$	5.0 5.0	5.23 5.23	5.5 5.5	V
17	$C_{CRD\_VCC}$	Output Capacitance on card power supply $CRD\_V_{CC}$ (Notes 4 and 5)	300	220 + 320	1000	nF
17	$CRD\_V_{CC}$	Output Card Supply Voltage @ $4.5\text{ V} < V_{DDP} < 5.5\text{ V}$ (including ripple) $CRD\_V_{CC} = 3.0\text{ V}$ @ $I_{load} \leq 65\text{ mA}$ $CRD\_V_{CC} = 5.0\text{ V}$ @ $I_{load} \leq 65\text{ mA}$	2.85 4.75	3.00 5.00	3.15 5.25	V

NOTE: Device will meet the specifications after thermal equilibrium has been established when mounted in a test socket or printed circuit board with maintained transverse airflow greater than 500 lfm. Electrical parameters are guaranteed only over the declared operating temperature range. Functional operation of the device exceeding these conditions is not implied. Device specification limit values are applied individually under normal operating conditions and not valid simultaneously.

- Guaranteed by design and characterization
- These values take into account the tolerance of the cms capacitor used. The allowed values are single or distributed capacitor combination not exceeding  $1.0\text{ }\mu\text{F}$  with  $220\text{ nF} + 330\text{ nF}$  typical and recommended. It is recommended to use X5R or X7R-type capacitors with very low ESR ( $< 100\text{ m}\Omega$ ) for optimal performances.

# NCN8024

## POWER SUPPLY SECTION ( $V_{DD} = 3.3\text{ V}$ ; $V_{DDP} = 5\text{ V}$ ; $T_{amb} = 25^\circ\text{C}$ ; $F_{CLKIN} = 10\text{ MHz}$ )

Pin	Symbol	Rating	Min	Typ	Max	Unit
<b>DC/DC CONVERTER</b>						
17	CRD_VCC	Output Card Supply Voltage @ $3.6\text{ V} \leq V_{DDP} \leq 5.5\text{ V}$ with $ I_{CC}  \leq 65\text{ mA}$ load transient from 100 Hz to 200 MHz (including ripple) (Note 4) CRD_VCC = 3.0 V CRD_VCC = 5.0 V	2.76 4.65	3.00 5.00	3.20 5.25	V V
17	CRD_VCC	Output Card Supply Voltage @ $4.5\text{ V} < V_{DDP} < 5.5\text{ V}$ with Current-Load Pulses of 40 nAs/t < 400 ns and $ I_{CC}  < 200\text{ mA}$ Peak Current (Including Ripple) (Note 4) CRD_VCC = 3.0 V CRD_VCC = 5.0 V	2.76 4.65	3.00 5.00	3.20 5.25	V V
17	I <sub>CRD_VCC</sub>	Card Supply Current @ CRD_VCC = 3.0 V @ CRD_VCC = 5.0 V			75 75	mA
17	I <sub>CRD_VCC_SC</sub>	Short-Circuit Current - CRD_VCC Shorted to Ground		110	150	mA
17	$\Delta V_{CRD\_VCC}$	Output Card Supply Voltage Ripple Peak-to-Peak - $f_{ripple} = 100\text{ Hz}$ to 200 MHz (Load Transient with 65 mA Peak Current) (Note 4)			350	mV
17	CRD_VCCSR	Slew Rate on CRD_VCC Up or Down (Note 4)			0.22	V/ $\mu\text{s}$

NOTE: Device will meet the specifications after thermal equilibrium has been established when mounted in a test socket or printed circuit board with maintained transverse airflow greater than 500 lfm. Electrical parameters are guaranteed only over the declared operating temperature range. Functional operation of the device exceeding these conditions is not implied. Device specification limit values are applied individually under normal operating conditions and not valid simultaneously.

- Guaranteed by design and characterization
- These values take into account the tolerance of the cms capacitor used. The allowed values are single or distributed capacitor combination not exceeding 1.0  $\mu\text{F}$  with 220 nF + 330 nF typical and recommended. It is recommended to use X5R or X7R-type capacitors with very low ESR (< 100 m $\Omega$ ) for optimal performances.

## DIGITAL INPUT/OUTPUT SECTION CLKIN, RSTIN, I/Ouc, AUX1uc, AUX2uc, CLKDIV1, CLKDIV2, $\overline{\text{CMDVCC}}$ , 5V/3V

( $V_{DD} = 3.3\text{ V}$ ;  $V_{DDP} = 5\text{ V}$ ;  $T_{amb} = 25^\circ\text{C}$ ;  $F_{CLKIN} = 10\text{ MHz}$ )

Pin	Symbol	Rating	Min	Typ	Max	Unit
24	F <sub>CLKIN</sub>	Clock Frequency on Pin CLKIN (with Divider Ratio $\geq 2$ ) (Note 6)	-	-	27	MHz
1, 2, 3, 19, 20, 24, 26, 27, 28	V <sub>IL</sub>	Input Voltage Level Low: CLKIN, RSTIN, I/Ouc, AUX1uc, AUX2uc, CLKDIV1, CLKDIV2, $\overline{\text{CMDVCC}}$ , 5V/3V	-0.3	-	$0.3 \times V_{DD}$	V
1, 2, 3, 19, 20, 24, 26, 27, 28	V <sub>IH</sub>	Input Voltage Level High: CLKIN, RSTIN, I/O, AUX1, AUX2, CLKDIV1, CLKDIV2, $\overline{\text{CMDVCC}}$ , 5V/3V	$0.7 \times V_{DD}$	-	$V_{DD} + 0.3$	V
1, 2, 3, 19, 20, 24	I <sub>IL</sub>	CLKDIV1, CLKDIV2, $\overline{\text{CMDVCC}}$ , RSTIN, CLKIN, 5V/3V Low Level Input Leakage Current, $V_{IL} = 0\text{ V}$	-	-	1.0	$\mu\text{A}$
1, 2, 3, 19, 20, 24	I <sub>IH</sub>	CLKDIV1, CLKDIV2, $\overline{\text{CMDVCC}}$ , RSTIN, CLKIN, 5V/3V Low Level Input Leakage Current, $V_{IH} = V_{DD}$	-	-	1.0	$\mu\text{A}$
26, 27, 28	I <sub>IL</sub>	I/Ouc, AUX1uc, AUX2uc Low Level Input Leakage Current, $V_{IL} = 0\text{ V}$	-	-	600	$\mu\text{A}$
26, 27, 28	I <sub>IH</sub>	I/Ouc, AUX1uc, AUX2uc High Level Input Leakage Current, $V_{IH} = V_{DD}$	-	-	10	$\mu\text{A}$

NOTE: Device will meet the specifications after thermal equilibrium has been established when mounted in a test socket or printed circuit board with maintained transverse airflow greater than 500 lfm. Electrical parameters are guaranteed only over the declared operating temperature range. Functional operation of the device exceeding these conditions is not implied. Device specification limit values are applied individually under normal operating conditions and not valid simultaneously.

- Guaranteed by design and characterization

# NCN8024

## DIGITAL INPUT/OUTPUT SECTION CLKIN, RSTIN, I/Ouc, AUX1uc, AUX2uc, CLKDIV1, CLKDIV2, $\overline{CMDVCC}$ , 5V/3V

( $V_{DD} = 3.3\text{ V}$ ;  $V_{DDP} = 5\text{ V}$ ;  $T_{amb} = 25^\circ\text{C}$ ;  $F_{CLKIN} = 10\text{ MHz}$ )

Pin	Symbol	Rating	Min	Typ	Max	Unit
26, 27, 28	$V_{OH}$	I/Ouc, AUX1uc, AUX2uc data channels, @ $C_s \leq 30\text{ pF}$ High Level Output Voltage (CRD_I/O = CRD_AUX1 = CRD_AUX2 = CRD_VCC) $I_{OH} = 0$	$0.9 \times V_{DD}$	-	$V_{DD} + 0.1$	V
		$I_{OH} = -40\ \mu\text{A}$	$0.75 \times V_{DD}$	-	$V_{DD} + 0.1$	V
	$V_{OL}$	Low Level Output Voltage (C_I/O = CRD_AUX1 = CRD_AUX2 = 0 V) $I_{OL} = +1\text{ mA}$	0	-	0.3	V
	$t_{Ri/Fi}$	Input Rising/Falling Times (Note 6)	-	-	1.2	$\mu\text{s}$
	$t_{Ro/Fo}$	Output Rising/Falling Times (Note 6)	-	-	0.1	$\mu\text{s}$
26, 27, 28	$F_{bidi}$	Maximum Frequency through Bidirectional I/O, AUX1 and AUX2 Channels (Note 6)	-	-	1	MHz
26, 27, 28	$R_{pu}$	I/Ouc, AUX1uc, AUX2uc Pullup Resistor	8.0	11	16	k $\Omega$
23	$V_{OH}$	Output High Voltage INT @ $I_{OH} = -15\ \mu\text{A}$ (Source)	$0.75 \times V_{DD}$	-	-	V
23	$V_{OL}$	Output Low Voltage INT @ $I_{OL} = 2\text{ mA}$ (Sink)	0	-	0.30	V
23	$R_{INT}$	INT Pullup Resistor	14	20	26	k $\Omega$

NOTE: Device will meet the specifications after thermal equilibrium has been established when mounted in a test socket or printed circuit board with maintained transverse airflow greater than 500 lfm. Electrical parameters are guaranteed only over the declared operating temperature range. Functional operation of the device exceeding these conditions is not implied. Device specification limit values are applied individually under normal operating conditions and not valid simultaneously.

6. Guaranteed by design and characterization

# NCN8024

## SMART CARD INTERFACE SECTION, CRD\_IO, CRD\_AUX1, CRD\_AUX2, CRD\_CLK, CRD\_RST, CRD\_PRES, CRD\_PRES (V<sub>DD</sub> = 3.3 V; V<sub>DDP</sub> = 5 V; T<sub>amb</sub> = 25°C; F<sub>CLKIN</sub> = 10 MHz)

Pin	Symbol	Rating	Min	Typ	Max	Unit
16	V <sub>OH</sub> V <sub>OL</sub>	CRD_RST @ CRD_V <sub>CC</sub> = 3.0 V, 5.0 V	0.9 x CRD_V <sub>CC</sub> 0	-	CRD_V <sub>CC</sub> 0.20	V V
		Output RESET V <sub>OH</sub> @ I <sub>rst</sub> = -200 μA Output RESET V <sub>OL</sub> @ I <sub>rst</sub> = 200 μA				
	V <sub>OH</sub> V <sub>OL</sub>	Output RESET V <sub>OH</sub> @ I <sub>rst</sub> = -20 mA Output RESET V <sub>OL</sub> @ I <sub>rst</sub> = 20 mA	0 CRD_V <sub>CC</sub> - 0.4	-	0.4 CRD_V <sub>CC</sub>	V V
		t <sub>R</sub> t <sub>F</sub>	Output RESET Risettime @ C <sub>out</sub> = 100 pF (Note 7) Output RESET Falltime @ C <sub>out</sub> = 100 pF (Note 7)	-	-	100 100
	t <sub>d</sub>	RSTIN to CRD_RST Delay - Reset Enabled (Note 7)	-	-	2	μs
	15	F <sub>CRDCLK</sub>	CRD_CLK @ CRD_V <sub>CC</sub> = 3.0 V or 5.0 V	-	-	18
Output Frequency (Note 7)						
V <sub>OH</sub> V <sub>OL</sub>		Output CRD_CLK V <sub>OH</sub> @ I <sub>clk</sub> = -200 μA Output CRD_CLK V <sub>OL</sub> @ I <sub>clk</sub> = 200 μA	0.9 x CRD_V <sub>CC</sub> 0	-	CRD_V <sub>CC</sub> +0.2	V V
		V <sub>OH</sub> V <sub>OL</sub>	Output CRD_CLK V <sub>OH</sub> @ I <sub>clk</sub> = -70 mA Output CRD_CLK V <sub>OL</sub> @ I <sub>clk</sub> = 70 mA	0 CRD_V <sub>CC</sub> - 0.4	-	0.4 CRD_V <sub>CC</sub>
F <sub>DC</sub>		Output Duty Cycle (Note 7)	45	-	55	%
t <sub>rlls</sub> t <sub>ulsa</sub>		Rise & Fall time (Note 5) Output CRD_CLK Risettime @ C <sub>out</sub> = 30 pF Output CRD_CLK Falltime @ C <sub>out</sub> = 30 pF	-	-	16 16	ns ns
SR		Slew Rate @ C <sub>out</sub> = 33 pF (Note 7)	0.2	-	-	V/ns
11, 12, 13		V <sub>IH</sub> V <sub>IH</sub> V <sub>IL</sub>	CRD_AUX1, CRD_AUX2, CRD_IO @ CRD_V <sub>CC</sub> = 3.0 V, 5.0 V	2.5 1.6 0.30	-	CRD_V <sub>CC</sub> +0.3 CRD_V <sub>CC</sub> +0.3 0.80
	Input Voltage High Level (5 V Mode)					
	Input Voltage High Level (3 V Mode)					
	I <sub>IL</sub> I <sub>IH</sub>	Input Voltage Low Level	-	-	600 10	μA μA
		Low Level Input Current V <sub>IL</sub> = 0 V High Level Input Current V <sub>IH</sub> = CRD_V <sub>CC</sub>				
	V <sub>OH</sub>	Output V <sub>OH</sub> @ I <sub>OH</sub> = -40 μA	0.75 x CRD_V <sub>CC</sub>	-	CRD_V <sub>CC</sub> +0.1	V
	V <sub>OL</sub>	Output V <sub>OL</sub> @ I <sub>OL</sub> = 1 mA, V <sub>IL</sub> = 0 V	0	-	0.30	V
	t <sub>Ri/Fi</sub>	Input Rising/Falling Times	-	-	1.2	μs
t <sub>Ro/Fo</sub>	Output Rising/Falling Times / C <sub>out</sub> = 80 pF	-	-	0.1	μs	
11, 12, 13	R <sub>PU</sub>	CRD_AUX1, CRD_AUX2, CRD_IO Pullup Resistor	8.0	11	16	kΩ
	t <sub>IO</sub>	Propagation delay I <sub>Ouc</sub> -> CRD_IO and CRD_IO -> IOuc (Falling Edge) (Note 7)	-	-	200	ns
	t <sub>pu</sub>	Active pull-up pulse width buffers I/O, AUX1 & AUX2 (Note 7)	-	200	-	ns
9, 10	V <sub>IH</sub> V <sub>IL</sub>	CRD_PRES, CRD_PRES Card Presence Voltage High Level Card Presence Voltage Low Level	0.7 x V <sub>DD</sub> -0.3	-	V <sub>DD</sub> + 0.3 0.3 x V <sub>DD</sub>	V

NOTE: Device will meet the specifications after thermal equilibrium has been established when mounted in a test socket or printed circuit board with maintained transverse airflow greater than 500 lfm. Electrical parameters are guaranteed only over the declared operating temperature range. Functional operation of the device exceeding these conditions is not implied. Device specification limit values are applied individually under normal operating conditions and not valid simultaneously.

7. Guaranteed by design and characterization

**SMART CARD INTERFACE SECTION, CRD\_IO, CRD\_AUX1, CRD\_AUX2, CRD\_CLK, CRD\_RST, CRD\_PRES, CRD\_PRES** ( $V_{DD} = 3.3\text{ V}$ ;  $V_{DDP} = 5\text{ V}$ ;  $T_{amb} = 25^{\circ}\text{C}$ ;  $F_{CLKIN} = 10\text{ MHz}$ )

Pin	Symbol	Rating	Min	Typ	Max	Unit
9, 10	$ I_{IH} $	CRD_PRES, $\overline{\text{CRD\_PRES}}$ High level input leakage current, $V_{IH} = V_{DD}$		5	10	$\mu\text{A}$
	$ I_{IL} $	CRD_PRES $\overline{\text{CRD\_PRES}}$ Low level input leakage current, $V_{IL} = 0\text{ V}$		5	10	
9, 10	$T_{\text{debounce}}$	Debounce Time CRD_PRES and $\overline{\text{CRD\_PRES}}$ (Note 7)	5	8	11	ms
11, 12, 13, 16	$I_{\text{CRD\_IO}}$	CRD_IO, CRD_AUX1, CRD_AUX2 Current Limitation	–	–	15	mA
15	$I_{\text{CRD\_CLK}}$	CRD_CLK Current Limitation	–	–	70	mA
16	$I_{\text{CRD\_RST}}$	CRD_RST Current Limitation	–	–	20	mA
	$t_{\text{act}}$	Activation Time (Note 7)	30	–	100	$\mu\text{s}$
	$t_{\text{deact}}$	Deactivation Time (Note 7)	30	–	250	$\mu\text{s}$
	Temp <sub>SD</sub>	Shutdown Temperature	–	160	–	$^{\circ}\text{C}$

NOTE: Device will meet the specifications after thermal equilibrium has been established when mounted in a test socket or printed circuit board with maintained transverse airflow greater than 500 lfm. Electrical parameters are guaranteed only over the declared operating temperature range. Functional operation of the device exceeding these conditions is not implied. Device specification limit values are applied individually under normal operating conditions and not valid simultaneously.

7. Guaranteed by design and characterization

**POWER SUPPLY**

The NCN8024 smart card interface has two power supplies:  $V_{DD}$  and  $V_{DDP}$ .

$V_{DD}$  is usually common to the system controller and the interface. The applied  $V_{DD}$  ranges from 2.7 V up to 5.5 V. If  $V_{DD}$  goes below 2.35 V typical ( $UVLO_{VDD}$ ) a power-down sequence is automatically performed. In that case the interrupt ( $\overline{\text{INT}}$ ) pin is set Low.

A built-in charge-pump-based DC/DC converter followed by a Low Drop-Out (LDO) regulator is used to provide the 3 V or 5 V power supply voltage ( $CRD\_VCC$ ) to the card.  $V_{DDP}$  is the converter’s input voltage. VUP is the charge-pump converter’s output. It is connected to the LDO input. A reservoir capacitor of 100 nF is connected to VUP.  $CRD\_VCC$  is the LDO output. Even if the converter can operate with a single output reservoir capacitor as low as 100 nF at  $CRD\_VCC$ , it is recommended to use a capacitor of at least 320 nF in order to satisfy the datasheet specifications. The best recommended combination guaranteeing optimal performances consists in a distributed set of capacitors 220 nF + 330 nF (in particular recommended for optimally satisfying the NDS standard). To minimize dI/dt effects, the fly capacitor (100 nF) and the reservoir capacitors VUP and  $CRD\_VCC$  have to be connected as close as possible to the corresponding device’s pin and feature very low ESR values (lower than 50 m $\Omega$ ). The fly capacitor is connected between C1 and C2. The decoupling capacitors on  $V_{DD}$  and  $V_{DDP}$  respectively 100 nF and 10  $\mu\text{F}$  have also to be connected close to the respective IC pins.

The  $CRD\_VCC$  pin can source up to 75 mA continuously over the  $V_{DDP}$  range (from 3.3 V to 5.5 V), the absolute

maximum current being internally limited below 150 mA (Typical at 110 mA).  $CRD\_VCC$  can stay in the range 4.6 V – 5.30 V during current transient up to 200 mA (peak current) over less than 400 ns of current pulse duration such as the charge transient is lower than 40 nAs.

There’s no specific sequence for applying  $V_{DD}$  or  $V_{DDP}$ . They can be applied to the interface in any sequence. After powering the device  $\overline{\text{INT}}$  remains Low until a card is inserted.

**SUPPLY VOLTAGE MONITORING**

The supply voltage monitoring block includes the Power On Reset (POR) circuitry and the under voltage lockout (UVLO) detection ( $V_{DD}$  voltage dropout detection). PORADJ pin allows the user, according to the considered application, to adjust the  $V_{DD}$  UVLO threshold. If not used PORADJ pin is connected to Ground.

The input supply voltage is continuously monitored to prevent under voltage operation. At power up, the system initializes the internal logic during POR timing and no further signal can be provided or supported during this period. Such initialization takes place when the input voltage rises between 2 V to 2.6 V about typical.

The system is ready to operate when the input voltage has reached the minimum 2.7 V. Considering this, the NCN8024 will detect an Under-Voltage situation when the input supply voltage will drop below 2.35 V typical. When  $V_{DD}$  goes down below the UVLO falling threshold a deactivation sequence is performed.

The device is inactive during power-on and power-off of the  $V_{DD}$  supply (8 ms reset pulse).

PORADJ pin is used to modify the UVLO threshold according to the below relationship considering an external resistor divider R1 / R2 (see block diagram Figure 1):

$$UVLO = \frac{R1 + R2}{R2} V_{POR}$$

If PORADJ is connected to Ground the V<sub>DD</sub> UVLO threshold (V<sub>DD</sub> falling) is typically 2.35 V. In some cases it can be interesting to adjust this threshold at a higher value and by the way increase the V<sub>DD</sub> supply dropout detection level which enables a deactivation sequence if the V<sub>DD</sub> voltage is too low.

For example, there are microcontrollers for which the minimum supply voltage insuring a correct operating is higher than 2.55 V, increasing UVLO<sub>VDD</sub> (V<sub>DD</sub> falling) is consequently necessary. Considering for instance a resistor bridge with R1 = 56 kΩ, R2 = 42 kΩ and V<sub>POR-</sub> = 1.18 V typical the V<sub>DD</sub> dropout detection level can be increased up to:

$$UVLO = \frac{59k + 42k}{42k} V_{POR-} = 2.75 V$$

The minimum dropout detection voltage should be higher than 2 V.

The maximum detection level may be up to V<sub>DD</sub>.

**CLOCK DIVIDER:**

The input clock can be divided by 1/1, 1/2, 1/4, or 1/8, depending upon the specific application, prior to be applied to the smart card driver. These division ratios are programmed using pins CLKDIV1 and CLKDIV2 (see Table 1). The input clock is provided externally to pin CLKIN.

**Table 1. Clock Frequency Programming**

CLKDIV1	CLKDIV2	F <sub>CRD_CLK</sub>
0	0	CLKIN/8
0	1	CKLKIN / 4
1	0	CLKIN
1	1	CLKIN / 2

The clock input stage (CLKIN) can handle a 27 MHz maximum frequency signal (considering a division ratio ≥ 2). Of course, the ratio must be defined by the user to cope with Smart Card considered in a given application

In order to avoid any duty cycle out of the 45% / 55% range specification, the divider is synchronized by the last flip flop, thus yielding a constant 50% duty cycle, whatever be the divider ratio 1/2, 1/4 or 1/8. On the other hand, the output signal Duty Cycle cannot be guaranteed 50% if the division ratio is 1 and if the input Duty Cycle signal is not within the 46 – 56% range at the CLKIN input.

When the signal applied to CLKIN is coming from the external controller, the clock will be applied to the card under the control of the microcontroller or similar device after the activation sequence has been completed.

**DATA I/O, AUX1 and AUX2 LEVEL SHIFTERS**

The three bidirectional level shifters I/O, AUX1 and AUX2 adapt the voltage difference that might exist between the micro-controller and the smart card. These three channels are identical. The first side of the bidirectional level shifter dropping Low (falling edge) becomes the driver side until the level shifter enters again in the idle state pulling High CRD\_IO and I/Ouc.

Passive 11 kΩ pull-up resistors have been internally integrated on each terminal of the bidirectional channel. In addition with these pull-up resistors, an active pull-up circuit provides a fast charge of the stray capacitance.

The current to and from the card I/O lines is limited internally to 15 mA and the maximum frequency on these lines is 1 MHz.

**STANDBY MODE**

After a Power-on reset, the circuit enters the standby mode. A minimum number of circuits are active while waiting for the microcontroller to start a session:

- All card contacts are inactive
- Pins I/Ouc, AUX1uc and AUX2uc are in the high-impedance state (11 kΩ pull-up resistor to V<sub>DD</sub>)
- Card pins are inactive and pulled Low
- Supply Voltage monitoring is active
- The internal DC/DC converter oscillator is running.

**POWER-UP**

In the standby mode the microcontroller can check the presence of a card using the signals INT and CMDVCC as shown in Table 2:

**Table 2. Card Presence State**

INT	CMDVCC	State
HIGH	HIGH	Card present
LOW	HIGH	Card not present

If a card is detected present (CRD\_PRES or CRD\_PRES active) the controller can start a card session by pulling CMDVCC Low. Card activation is run (t<sub>0</sub>, Figure 5). This Power-Up Sequence makes sure all the card related signals are LOW during the CRD\_VCC positive going slope. These lines are validated when CRD\_VCC is stable and above the minimum voltage specified. When the CRD\_VCC voltage reaches the programmed value (3.0 V or 5.0 V), the circuit activates the card signals according to the following sequence (Figure 5):

- CRD\_VCC is powered-up at its nominal value (t1)
- I/O, AUX1 and AUX2 lines are activated (t2)
- Then Clock channel is activated and the clock signal is applied to the card (t3)
- Finally the Reset level shifter is enabled (t4)

The clock can also be applied to the card using a RSTIN mode allowing controlling the clock starting by setting RSTIN Low (Figure 4). Before running the activation sequence, that is before setting Low  $\overline{\text{CMDVCC}}$  RSTIN is set High. In these initial conditions CRD\_CLK starts when RSTIN is pulled Low. This allows a precise count of clock pulses before toggling CRD\_RST High for ATR (Answer To Reset) request.

The internal activation sequence activates the different channels according to a specific hardware built-in sequencing internally defined but at the end the actual activation sequencing is the responsibility of the application software and can be redefined by the micro-controller to comply with the different standards and the different ways the standards manage this activation (for example light differences exist between the EMV and the ISO7816 standards).

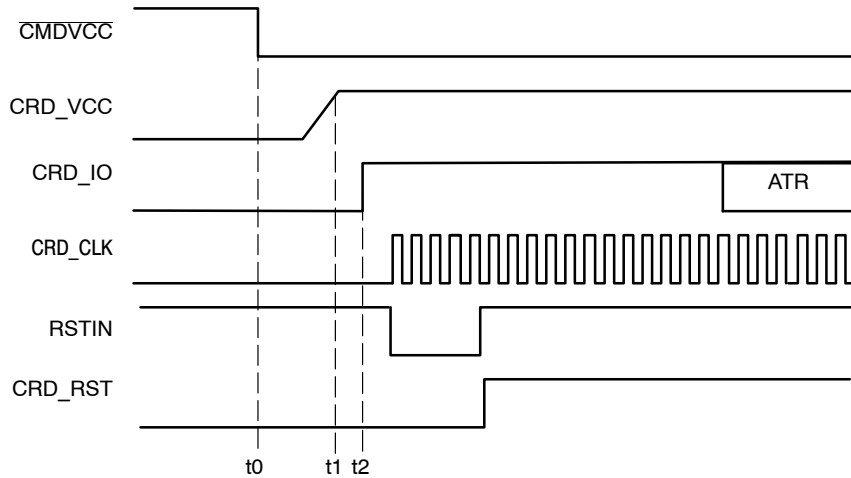

Figure 4. Activation Sequence – RSTIN mode (RSTIN Starting High)

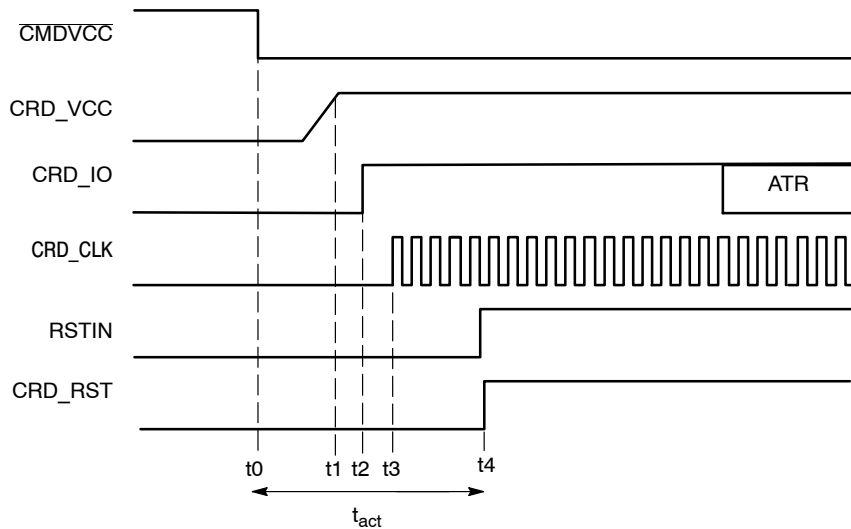
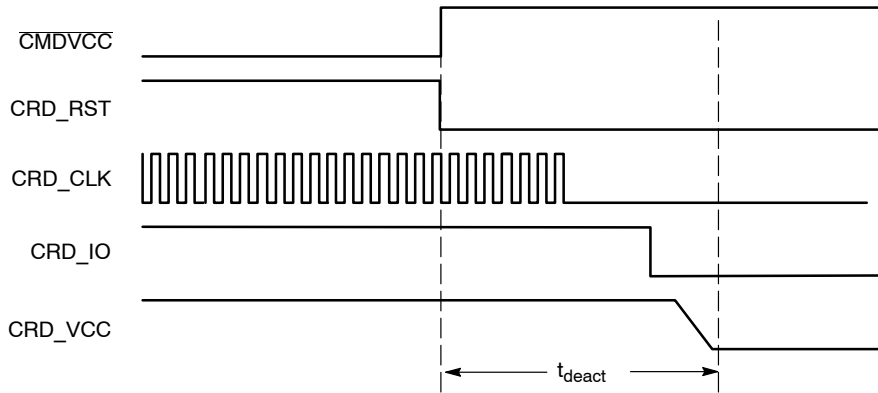

Figure 5. Activation Sequence – Normal Mode

**POWER-DOWN**

When the communication session is completed the NCN8024 runs a deactivation sequence by setting High  $\overline{\text{CMDVCC}}$ . The below power down sequence is executed:

- CRD\_RST is forced to Low
- CRD\_CLK is set Low 12  $\mu\text{s}$  after CRD\_RST.
- CRD\_IO, CRD\_AUX1 and CRD\_AUX2 are pulled Low
- Finally CRD\_VCC supply can be shut-off.

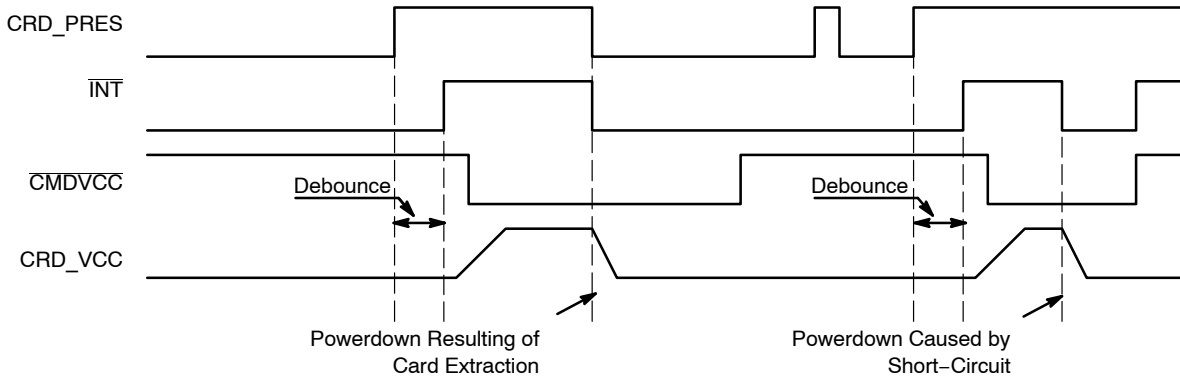

**Figure 6. Deactivation Sequence**

**FAULT DETECTION**

In order to protect both the interface and the external smart card, the NCN8024 provides security features to prevent failures or damages as depicted here after.

- Card extraction detection
- $V_{DD}$  under voltage detection
- Short-circuit or overload on CRD\_VCC
- Card pin current limitation: in the case of a short circuit to ground. No feedback is provided to the external MPU.
- DC/DC operation: the internal circuit continuously senses the CRD\_VCC voltage (in the case of either over or under voltage situation).
- DC/DC operation: under-voltage detection on  $V_{DDP}$  or overload on VUP
- Overheating



**Figure 7. Fault Detection and Interrupt Management**

**Interrupt Pin Management:**

A card session is opened by toggling  $\overline{\text{CMDVCC}}$  High to Low.

Before a card session,  $\overline{\text{CMDVCC}}$  is supposed to be in a High position.  $\overline{\text{INT}}$  is Low if no card is present in the card connector (Normally open or normally closed type).  $\overline{\text{INT}}$  is High if a card is present. If a card is inserted ( $\overline{\text{INT}} = \text{High}$ ) and if  $V_{DD}$  drops below the UVLO threshold then  $\overline{\text{INT}}$  pin drops Low immediately. It turns back High when  $V_{DD}$  increases again over the UVLO limit (including hysteresis), a card being still present.

During a card session,  $\overline{\text{CMDVCC}}$  is Low and  $\overline{\text{INT}}$  pin goes Low when a fault is detected. In that case a deactivation is immediately and automatically performed (see Figure 6). When the microcontroller resets  $\overline{\text{CMDVCC}}$  to High it can sense the  $\overline{\text{INT}}$  level again after having got completed the deactivation.

As illustrated by Figure 7 the device has a debounce timer of 8 ms typical duration. When a card is inserted, output  $\overline{\text{INT}}$  goes High only at the end of the debounce time. When the card is removed a deactivation sequence is automatically and immediately performed and  $\overline{\text{INT}}$  goes Low.

## NCN8024

### ESD PROTECTION

The NCN8024 includes devices to protect the pins against the ESD spikes voltages. To cope with the different ESD voltages developed across these pins, the built in structures have been designed to handle either 2 kV, when related to the micro controller side, or 8 kV when connected with the external contacts (HBM model). Practically, the CRD\_RST,

CRD\_CLK, CRD\_IO, CRD\_AUX1, CRD\_AUX2, CRD\_PRES and CRD\_PRES pins can sustain 8 kV. The CRD\_VCC pin has the same ESD protection and can source up to 75 mA continuously, the absolute maximum current being internally limited with a max at 150 mA. The CRD\_VCC current limit depends on  $V_{DDP}$  and CRD\_VCC.

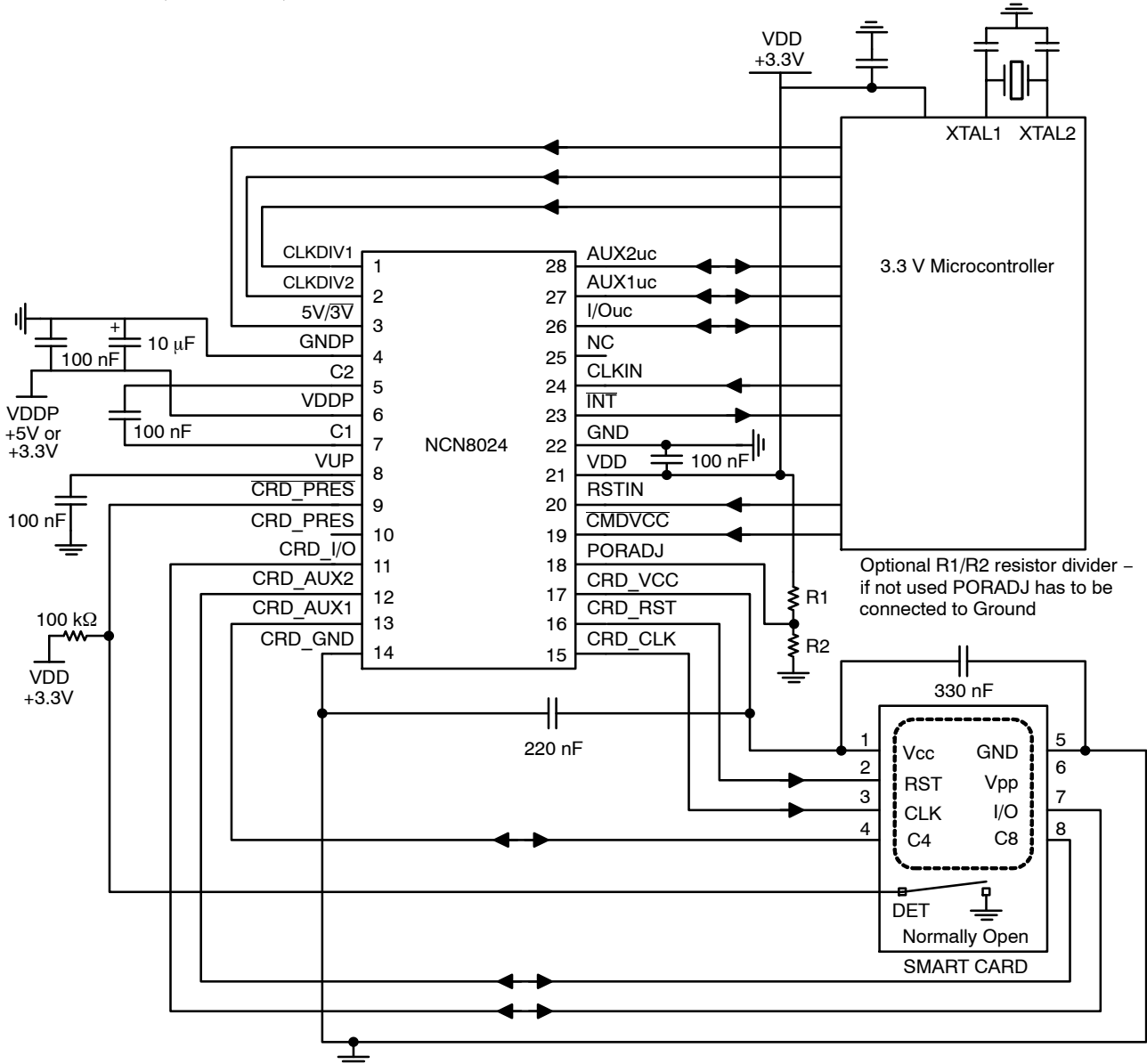

Figure 8. Application Schematic

### ORDERING INFORMATION

Device	Package	Shipping <sup>†</sup>
NCN8024DWR2G	SOIC-28 (Pb-Free)	1000 / Tape & Reel
NCN8024DTBR2G*	TSSOP-28 (Pb-Free)	2500 / Tape & Reel

<sup>†</sup>For information on tape and reel specifications, including part orientation and tape sizes, please refer to our Tape and Reel Packaging Specifications Brochure, BRD8011/D.

\*Consult Sales Office

# MECHANICAL CASE OUTLINE PACKAGE DIMENSIONS

ON Semiconductor®

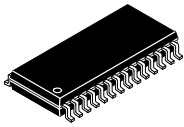

SCALE 1:1

SOIC-28 WB  
CASE 751F  
ISSUE J

DATE 23 SEP 2015

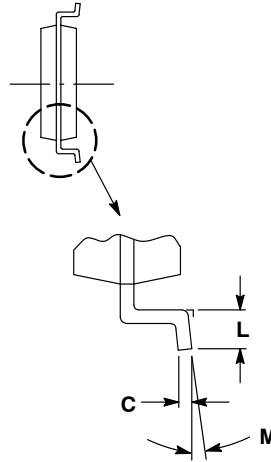
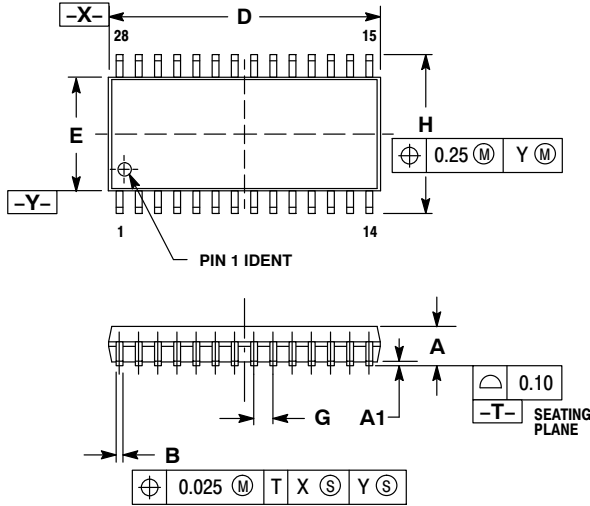

NOTES:

1. DIMENSIONING AND TOLERANCING PER ANSI Y14.5M, 1982.
2. CONTROLLING DIMENSION: MILLIMETER.
3. DIMENSIONS D AND E DO NOT INCLUDE MOLD PROTRUSION
4. MAXIMUM MOLD PROTRUSION 0.15 PER SIDE.
5. DIMENSION B DOES NOT INCLUDE DAMBAR PROTRUSION. ALLOWABLE DAMBAR PROTRUSION SHALL NOT BE 0.13 TOTAL IN EXCESS OF B DIMENSION AT MAXIMUM MATERIAL CONDITION.

DIM	MILLIMETERS	
	MIN	MAX
A	2.35	2.65
A1	0.13	0.29
B	0.35	0.49
C	0.23	0.32
D	17.80	18.05
E	7.40	7.60
G	1.27 BSC	
H	10.05	10.55
L	0.41	0.90
M	0°	8°

SOLDERING FOOTPRINT

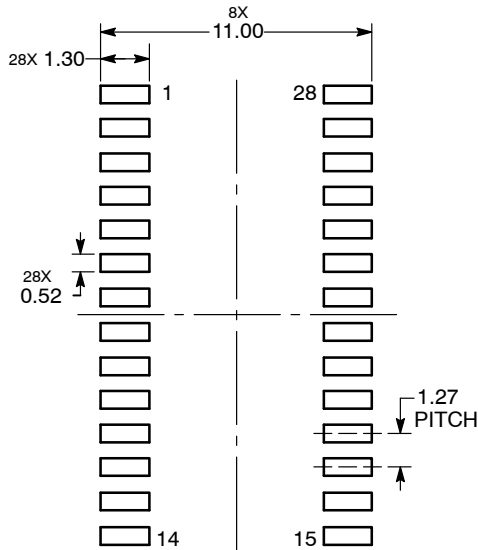

DIMENSIONS: MILLIMETERS

GENERIC MARKING DIAGRAM\*

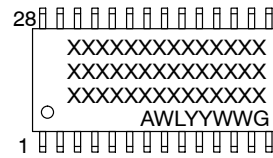

- XXXXX = Specific Device Code
- A = Assembly Location
- WL = Wafer Lot
- Y = Year
- WW = Work Week
- G = Pb-Free Package

\*This information is generic. Please refer to device data sheet for actual part marking. Pb-Free indicator, "G" or microdot "•", may or may not be present.

DOCUMENT NUMBER:	98ASB42345B	Electronic versions are uncontrolled except when accessed directly from the Document Repository. Printed versions are uncontrolled except when stamped "CONTROLLED COPY" in red.
DESCRIPTION:	SOIC-28 WIDE BODY	PAGE 1 OF 1

ON Semiconductor and are trademarks of Semiconductor Components Industries, LLC dba ON Semiconductor or its subsidiaries in the United States and/or other countries. ON Semiconductor reserves the right to make changes without further notice to any products herein. ON Semiconductor makes no warranty, representation or guarantee regarding the suitability of its products for any particular purpose, nor does ON Semiconductor assume any liability arising out of the application or use of any product or circuit, and specifically disclaims any and all liability, including without limitation special, consequential or incidental damages. ON Semiconductor does not convey any license under its patent rights nor the rights of others.

# MECHANICAL CASE OUTLINE PACKAGE DIMENSIONS

ON Semiconductor®



SCALE 1:1

TSSOP28  
CASE 948AA  
ISSUE A

DATE 26 OCT 2011

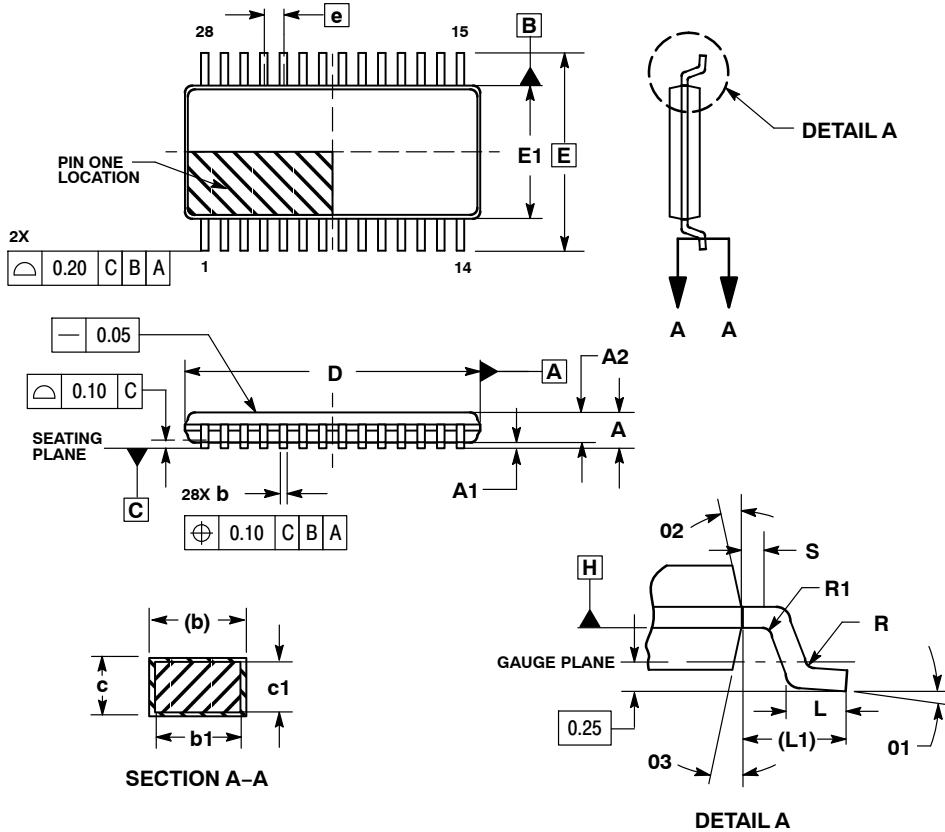

NOTES:

1. DIMENSIONS AND TOLERANCING PER ASME Y14.5M, 1994.
2. DIMENSIONS IN MILLIMETERS.
3. DIMENSION b DOES NOT INCLUDE DAMBAR PROTRUSION. ALLOWABLE DAMBAR PROTRUSION SHALL BE 0.08 MM TOTAL IN EXCESS OF THE "b" DIMENSION AT MAXIMUM MATERIAL CONDITION.
4. DATUMS A AND B TO BE DETERMINED AT DATUM PLANE H.

MILLIMETERS		
DIM	MIN	MAX
A	---	1.20
A1	0.05	0.15
A2	0.80	1.05
b	0.19	0.30
b1	0.19	0.25
c	0.09	0.20
c1	0.09	0.16
D	9.60	9.80
E	6.40	BSC
E1	4.30	4.50
e	0.65	BSC
L	0.45	0.75
L1	1.00	REF
R	0.09	---
R1	0.09	---
S	0.20	---
01	0°	8°
02	12°	REF
03	12°	REF

GENERIC MARKING DIAGRAM\*

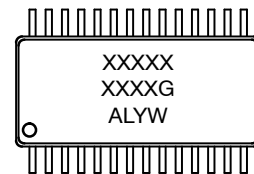

- XXXXX = Specific Device Code
- A = Assembly Location
- L = Wafer Lot
- Y = Year
- W = Work Week
- G = Pb-Free Package

\*This information is generic. Please refer to device data sheet for actual part marking.

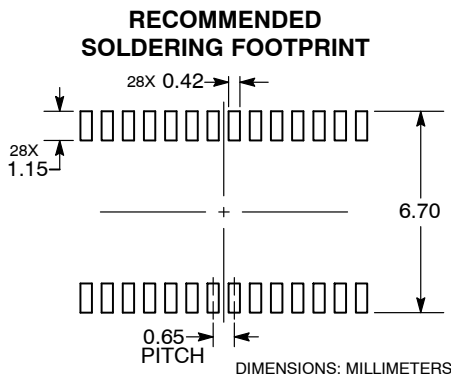

DOCUMENT NUMBER:	98AON13023D	Electronic versions are uncontrolled except when accessed directly from the Document Repository. Printed versions are uncontrolled except when stamped "CONTROLLED COPY" in red.
DESCRIPTION:	28 LEAD TSSOP, 9.7X4.4X1.0 MM, 0.65 PITCH	PAGE 1 OF 1

ON Semiconductor and ON are trademarks of Semiconductor Components Industries, LLC dba ON Semiconductor or its subsidiaries in the United States and/or other countries. ON Semiconductor reserves the right to make changes without further notice to any products herein. ON Semiconductor makes no warranty, representation or guarantee regarding the suitability of its products for any particular purpose, nor does ON Semiconductor assume any liability arising out of the application or use of any product or circuit, and specifically disclaims any and all liability, including without limitation special, consequential or incidental damages. ON Semiconductor does not convey any license under its patent rights nor the rights of others.

**onsemi**, **Onsemi**, and other names, marks, and brands are registered and/or common law trademarks of Semiconductor Components Industries, LLC dba "**onsemi**" or its affiliates and/or subsidiaries in the United States and/or other countries. **onsemi** owns the rights to a number of patents, trademarks, copyrights, trade secrets, and other intellectual property. A listing of **onsemi**'s product/patent coverage may be accessed at [www.onsemi.com/site/pdf/Patent-Marking.pdf](http://www.onsemi.com/site/pdf/Patent-Marking.pdf). **onsemi** reserves the right to make changes at any time to any products or information herein, without notice. The information herein is provided "as-is" and **onsemi** makes no warranty, representation or guarantee regarding the accuracy of the information, product features, availability, functionality, or suitability of its products for any particular purpose, nor does **onsemi** assume any liability arising out of the application or use of any product or circuit, and specifically disclaims any and all liability, including without limitation special, consequential or incidental damages. Buyer is responsible for its products and applications using **onsemi** products, including compliance with all laws, regulations and safety requirements or standards, regardless of any support or applications information provided by **onsemi**. "Typical" parameters which may be provided in **onsemi** data sheets and/or specifications can and do vary in different applications and actual performance may vary over time. All operating parameters, including "Typicals" must be validated for each customer application by customer's technical experts. **onsemi** does not convey any license under any of its intellectual property rights nor the rights of others. **onsemi** products are not designed, intended, or authorized for use as a critical component in life support systems or any FDA Class 3 medical devices or medical devices with a same or similar classification in a foreign jurisdiction or any devices intended for implantation in the human body. Should Buyer purchase or use **onsemi** products for any such unintended or unauthorized application, Buyer shall indemnify and hold **onsemi** and its officers, employees, subsidiaries, affiliates, and distributors harmless against all claims, costs, damages, and expenses, and reasonable attorney fees arising out of, directly or indirectly, any claim of personal injury or death associated with such unintended or unauthorized use, even if such claim alleges that **onsemi** was negligent regarding the design or manufacture of the part. **onsemi** is an Equal Opportunity/Affirmative Action Employer. This literature is subject to all applicable copyright laws and is not for resale in any manner.

## ADDITIONAL INFORMATION

### TECHNICAL PUBLICATIONS:

Technical Library: [www.onsemi.com/design/resources/technical-documentation](http://www.onsemi.com/design/resources/technical-documentation)  
onsemi Website: [www.onsemi.com](http://www.onsemi.com)

### ONLINE SUPPORT: [www.onsemi.com/support](http://www.onsemi.com/support)

For additional information, please contact your local Sales Representative at [www.onsemi.com/support/sales](http://www.onsemi.com/support/sales)

## Looking for pricing, stock, or lifecycle information?

Click below to explore more details on WIN SOURCE:

 [View NCN8024DWR2G on WIN SOURCE](#)

 [ON Semiconductor](#) Information

## Optimize Your Supply Chain with WIN SOURCE Solutions

-  Global Sourcing Solution
-  Obsolete Management
-  Cost Control Management
-  Shortage Management
-  Alternative Solution
-  Excess Inventory Management