



**THE DATASHEET OF
NCN4555MNR2G**



NCN4555

PIN DESCRIPTIONS

PIN	Name	Type	Description
1	$\overline{\text{STOP}}$	INPUT	Power Down Mode pin: $\overline{\text{STOP}} = \text{Low} \rightarrow$ Low current shutdown mode activated $\overline{\text{STOP}} = \text{High} \rightarrow$ Normal Operation A Low level on this pin resets the SIM interface, switching off the SIM_VCC.
2	MOD_VCC	INPUT	The signal present on this pin programs the SIM_VCC value: MOD_VCC = Low \rightarrow SIM_VCC = 1.8 V MOD_VCC = High \rightarrow SIM_VCC = 3 V
3	VDD	POWER	This pin is connected to the system controller power supply. It configures the level shifter input stage to accept the signals coming from the microprocessor. A 0.1 μF capacitor shall be used to bypass the power supply voltage. When VDD is below 1.1 V typical the SIM_VCC is disabled. The NCN4555 comes into a shutdown mode.
4	NC		No Connect
5	VBAT	POWER	DC-DC converter supply input. The input voltage ranges from 2.7V up to 5.5V. This pin has to be bypass by a 0.1 μF capacitor.
6	NC		No Connect
7	SIM_VCC	POWER	This pin is connected to the SIM card power supply pin. An internal LDO converter is programmable by the external MPU to supply either 1.8 V or 3.0 V output voltage. An external 1.0 μF minimum ceramic capacitor recommended must be connected across SIM_VCC and GND. During a normal operation, the SIM_VCC voltage can be set to 1.8 V followed by a 3.0 V value, or can start directly to any of these two values.
8	SIM_I/O	INPUT/ OUTPUT	This pin handles the connection to the serial I/O of the card connector. A bidirectional level translator adapts the serial I/O signal between the card and the micro controller. A 14 k Ω (typical) pullup resistor provides a High impedance state for the SIM card I/O link.
9	SIM_RST	OUTPUT	This pin is connected to the RESET pin of the card connector. A level translator adapts the external Reset (RST) signal to the SIM card.
10	GND	GROUND	This pin is the GROUND reference for the integrated circuit and associated signals. Care must be taken to avoid voltage spikes when the device operates in a normal operation.
11	SIM_CLK	OUTPUT	This pin is connected to the CLOCK pin of the card connector. The CLOCK (CLK) signal comes from the external clock generator, the internal level shifter being used to adapt the voltage defined for the SIM_VCC.
12	NC		No Connect
13	CLK	INPUT	The clock signal, coming from the external controller, must have a Duty Cycle within the Min/Max values defined by the specification (typically 50%). The built-in level shifter translates the input signal to the external SIM card CLK input.
14	RST	INPUT	The RESET signal present at this pin is connected to the SIM card through the internal level shifter which translates the level according to the SIM_VCC programmed value.
15	I/O	INPUT/ OUTPUT	This pin is connected to an external microcontroller or cellular phone management unit. A bidirectional level translator adapts the serial I/O signal between the smart card and the external controller. A built-in constant 18 k Ω (typical) resistor provides a high impedance state when not activated.
16	NC		No Connect

NCN4555

ATTRIBUTES

Characteristics	Values
ESD protection HBM, SIM card pins (7, 8, 9, 10 & 11) (Note 1) HBM, All other pins (Note 1) MM, SIM card pins (7, 8, 9, 10 & 11) (Note 2) MM, All other pins (Note 2) CDM, SIM card pins (7, 8, 9, 10 & 11) (Note 3) CDM, All other pins (Note 3)	> 7 kV > 2 kV > 600 V > 200 V > 2 kV > 600 V
Moisture sensitivity (Note 4) QFN-16	Level 1
Flammability Rating Oxygen Index: 28 to 34	UL 94 V-0 @ 0.125 in
Meets or exceeds JEDEC Spec EIA/JESD78 IC Latchup Test	

1. Human Body Model, R = 1500 Ω, C = 100 pF.
2. Machine Model.
3. CDM, Charged Device Model.
4. For additional information, see Application Note AND8003/D.

MAXIMUM RATINGS (Note 5)

Rating	Symbol	Value	Unit
LDO Power Supply Voltage	V _{BAT}	-0.5 ≤ V _{BAT} ≤ 6	V
Power Supply from Microcontroller Side	V _{DD}	-0.5 ≤ V _{DD} ≤ 6	V
External Card Power Supply	SIM_V _{CC}	-0.5 ≤ SIM_V _{CC} ≤ 6	V
Digital Input Pins	V _{in} I _{in}	-0.5 ≤ V _{in} ≤ V _{DD} + 0.5 but < 6.0 ±5	V mA
Digital Output Pins	V _{out} I _{out}	-0.5 ≤ V _{out} ≤ V _{DD} + 0.5 but < 6.0 ±10	V mA
SIM card Output Pins	V _{out} I _{out}	-0.5 ≤ V _{out} ≤ SIM_V _{CC} + 0.5 but < 6.0 15 (internally limited)	V mA
QFN-16 Low Profile package Power Dissipation @ T _A = +85°C Thermal Resistance Junction-to-Air	P _D R _{θJA}	440 90	mW °C/W
Operating Ambient Temperature Range	T _A	-40 to +85	°C
Operating Junction Temperature Range	T _J	-40 to +125	°C
Maximum Junction Temperature	T _{Jmax}	+125	°C
Storage Temperature Range	T _{stg}	-65 to +150	°C

Stresses exceeding Maximum Ratings may damage the device. Maximum Ratings are stress ratings only. Functional operation above the Recommended Operating Conditions is not implied. Extended exposure to stresses above the Recommended Operating Conditions may affect device reliability.

5. Maximum electrical ratings are defined as those values beyond which damage to the device may occur at T_A = +25°C

NCN4555

POWER SUPPLY SECTION (-40°C to +85°C)

Pin	Symbol	Rating	Min	Typ	Max	Unit
5	V _{BAT}	Power Supply	2.7		5.5	V
5	I _{V_{BAT}}	Operating current – I _{CC} = 0 mA (Note 6)		22	30	μA
5	I _{V_{BAT}_SD}	Shutdown current – $\overline{\text{STOP}}$ = Low (Note 7)			3.0	μA
3	V _{DD}	Operating Voltage	1.6		5.5	V
3	I _{V_{DD}}	Operating Current – f _{CLK} = 1 MHz (Note 8)		7.0	12	μA
3	I _{V_{DD}_SD}	Shutdown Current – $\overline{\text{STOP}}$ = Low			1.0	μA
3	V _{DD}	Undervoltage Lockout	0.6		1.5	V
7	SIM_V _{CC}	MOD_V _{CC} = High, V _{BAT} = 3.0 V, I _{SIM_V_{CC}} = 50 mA MOD_V _{CC} = High, V _{BAT} = 3.3 V to 5.5 V, I _{SIM_V_{CC}} = 0 mA to 50 mA MOD_V _{CC} = Low, V _{BAT} = 2.7 V to 5.5 V, I _{SIM_V_{CC}} = 0 mA to 50 mA	2.8 2.8 1.7	2.8 3.0 1.8	3.2 3.2 1.9	V V V
7	I _{SIM_V_{CC}_SC}	Short-Circuit Current – SIM_V _{CC} shorted to ground, T _A = 25°C			175	mA

NOTE: Device will meet the specifications after thermal equilibrium has been established when mounted in a test socket or printed circuit board with maintained transverse airflow greater than 500 lpm. Electrical parameters are guaranteed only over the declared operating temperature range. Functional operation of the device exceeding these conditions is not implied. Device specification limit values are applied individually under normal operating conditions and not valid simultaneously.

6. As long as V_{BAT} – V_{DD} ≤ 2.5 V. For V_{BAT} – V_{DD} > 2.5 V the maximum value increases up to 35 μA (typical being in the +25 μA range).

7. As long as V_{BAT} – V_{DD} ≤ 2.5 V.

8. Guaranteed by design over the operating temperature range specified.

DIGITAL INPUT/OUTPUT SECTION CLOCK, RESET, I/O, $\overline{\text{STOP}}$, MOD_V_{CC}

Pin	Symbol	Rating	Min	Typ	Max	Unit
1,2, 13, 14, 15	V _{in}	Input Voltage Range ($\overline{\text{STOP}}$, MOD_V _{CC} , RST, CLK, I/O)	0		V _{DD}	V
	I _{IH} & I _{IL}	Input Current ($\overline{\text{STOP}}$, MOD_V _{CC} , RST, CLK)	-100		100	nA
13, 14	V _{IH} V _{IL}	High Level Input Voltage (RST, CLK) Low Level Input Voltage (RST, CLK)	0.7 * V _{DD} (Note 9)		V _{DD} 0.4	V V
1, 2	V _{IH} V _{IL}	High Level Input Voltage ($\overline{\text{STOP}}$, MOD_V _{CC}) Low Level Input Voltage ($\overline{\text{STOP}}$, MOD_V _{CC})	0.7 * V _{DD} (Note 9) 0		V _{DD} 0.4	V V
15	V _{OH_I/O} V _{OL_I/O} I _{IH} I _{IL}	High Level Output Voltage (SIM_I/O = SIM_V _{CC} , I _{OH_I/O} = -20 μA) Low Level Output Voltage (SIM_I/O = 0 V, I _{OH_I/O} = 200 μA) High Level Input Current (I/O) Low Level Input Current (I/O)	0.7 * V _{DD} 0 -20		V _{DD} 0.4 20 1.0	V V μA mA
15	R _{pu_I/O}	I/O Pullup Resistor	12	18	24	kΩ

NOTE: Device will meet the specifications after thermal equilibrium has been established when mounted in a test socket or printed circuit board with maintained transverse airflow greater than 500 lpm. Electrical parameters are guaranteed only over the declared operating temperature range. Functional operation of the device exceeding these conditions is not implied. Device specification limit values are applied individually under normal operating conditions and not valid simultaneously.

9. If 1.6 V ≤ V_{DD} ≤ 1.8 V then V_{IHmin} = 1.26 V.

NCN4555

SIM INTERFACE SECTION (Note 10)

Pin	Symbol	Rating	Min	Typ	Max	Unit
9	SIM_RST	<p>SIM_VCC = +3.0 V (MOD_VCC = High) Output RESET V_{OH} @ I_{sim_rst} = -20 μA Output RESET V_{OL} @ I_{sim_rst} = +200 μA Output RESET Rise Time @ Cout = 30 pF Output RESET Fall Time @ Cout = 30 pF</p> <p>SIM_VCC = +1.8 V (MOD_VCC = Low) Output RESET V_{OH} @ I_{sim_rst} = -20 μA Output RESET V_{OL} @ I_{sim_rst} = +200 μA Output RESET Rise Time @ Cout = 30 pF Output RESET Fall Time @ Cout = 30 pF</p>	<p>0.9 * SIM_VCC 0</p> <p>0.9 * SIM_VCC 0</p>		<p>SIM_VCC 0.4 1 1</p> <p>SIM_VCC 0.4 1 1</p>	<p>V V μs μs</p> <p>V V μs μs</p>
11	SIM_CLK	<p>SIM_VCC = +3.0 V (MOD_VCC = High) Output Duty Cycle Max Output Frequency Output V_{OH} @ I_{sim_clk} = -20 μA Output V_{OL} @ I_{sim_clk} = +200 μA Output SIM_CLK Rise Time @ Cout = 30 pF Output SIM_CLK Fall Time @ Cout = 30 pF</p> <p>SIM_VCC = +1.8 V (MOD_VCC = Low) Output Duty Cycle Max Output Frequency Output V_{OH} @ I_{sim_clk} = -20 μA Output V_{OL} @ I_{sim_clk} = +200 μA Output SIM_CLK Rise Time @ Cout = 30 pF Output SIM_CLK Fall Time @ Cout = 30 pF</p>	<p>40 5 0.9 * SIM_VCC 0</p> <p>40 5 0.9 * SIM_VCC 0</p>		<p>60 SIM_VCC 0.4 18 18</p> <p>60 SIM_VCC 0.4 18 18</p>	<p>% MHz V V ns ns</p> <p>% MHz V V ns ns</p>
8	SIM_I/O	<p>SIM_VCC = +3.0 V (MOD_VCC = High) Output V_{OH} @ I_{SIM_IO} = -20 μA, V_{I/O} = V_{DD} Output V_{OL} @ I_{SIM_IO} = +1 mA, V_{I/O} = 0 V SIM_I/O Rise Time @ C_{out} = 30 pF SIM_I/O Fall Time @ C_{out} = 30 pF</p> <p>SIM_VCC = +1.8 V (MOD_VCC = High) Output V_{OH} @ I_{SIM_IO} = -20 μA, V_{I/O} = V_{DD} Output V_{OL} @ I_{SIM_IO} = +1.0 mA, V_{I/O} = 0 V SIM_I/O Rise Time @ C_{out} = 30 pF SIM_I/O Fall Time @ C_{out} = 30 pF</p>	<p>0.8 * SIM_VCC 0</p> <p>0.8 * SIM_VCC 0</p>		<p>SIM_VCC 0.4 1 1</p> <p>SIM_VCC 0.3 1 1</p>	<p>V V μs μs</p> <p>V V μs μs</p>
8	R _{pu_SIM_I/O}	Card I/O Pullup Resistor	10	14	18	kΩ

NOTE: Device will meet the specifications after thermal equilibrium has been established when mounted in a test socket or printed circuit board with maintained transverse airflow greater than 500 lpm. Electrical parameters are guaranteed only over the declared operating temperature range. Functional operation of the device exceeding these conditions is not implied. Device specification limit values are applied individually under normal operating conditions and not valid simultaneously.

10. All the dynamic specifications (AC specifications) are guaranteed by design over the operating temperature range.

TYPICAL CHARACTERISTICS

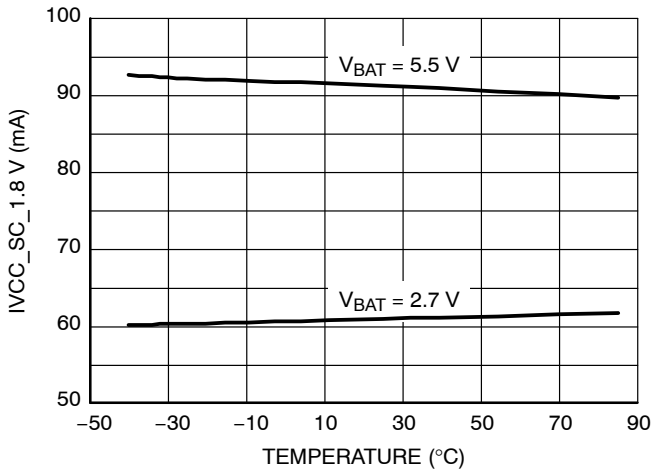

Figure 4. Short Circuit Current $I_{V_{CC_SC}}$ vs Temperature at $SIM_V_{CC} = 1.8 V$ ($MOD_V_{CC} = LOW$)

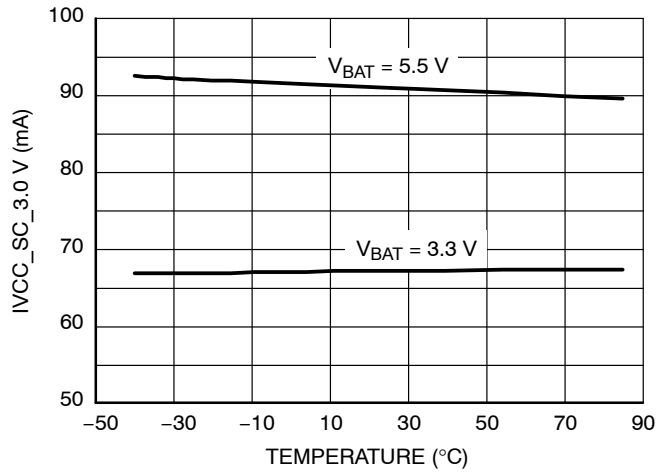

Figure 5. Short Circuit Current $I_{V_{CC_SC}}$ vs Temperature at $SIM_V_{CC} = 3.0 V$ ($MOD_V_{CC} = HIGH$)

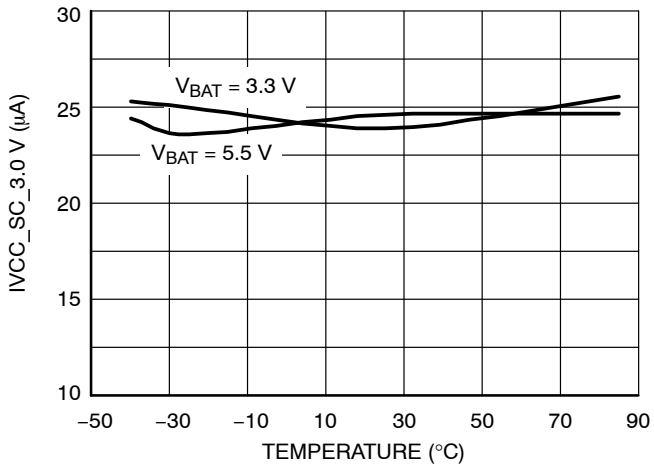

Figure 6. I_{BAT} vs temperature at 3.0 V

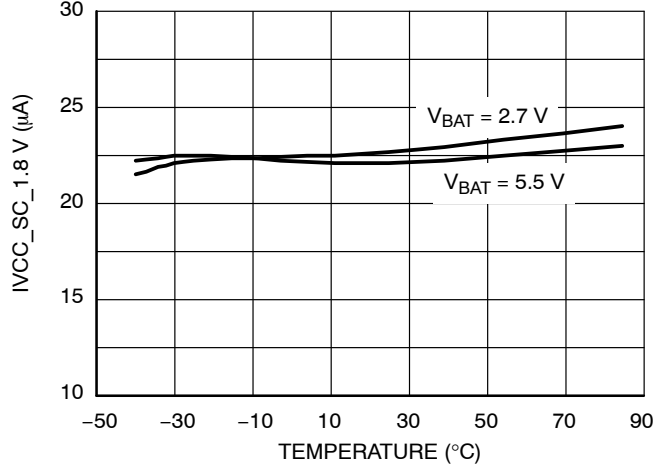

Figure 7. I_{BAT} vs Temperature at 1.8 V

APPLICATION INFORMATION

CARD SUPPLY CONVERTER

The NCN4555 interface DC-DC converter is a Low Dropout Voltage Regulator capable of supplying a current in excess of 50 mA under 1.8 V or 3.0 V. This device features a very low quiescent current typically lower than 25 μ A (Figure 6 and 7). MOD_VCC is a select input allowing a logic level signal to select a regulated voltage of 1.8 V (MOD_VCC = LOW) or 3.0 V (MOD_VCC = HIGH). Additionally, the NCN4555 has a shutdown input allowing it to turn off or turn on the regulator output. The shutdown mode power consumption is typically in the range of a few tens of nA (30 nA Typical). Figure 8 shows a simplified view of the NCN4555 voltage regulator. The SIM_VCC output is internally current limited and protected against short circuits. The short-circuit current I_{VCC} is constant over the temperature and SIM_VCC. It varies with VBAT typically in the range of 60 mA to 90 mA (Figure 4 and 5).

In order to guarantee a stable and satisfying operating of the LDO the SIM_VCC output will be connected to a 1.0 μ F bypass ceramic capacitor to the ground. At the input, VBAT will be bypassed to the ground with a 0.1 μ F ceramic capacitor.

LEVEL SHIFTERS

The level shifters accommodate the voltage difference that might exist between the microcontroller and the smart card. The RESET and CLOCK level shifters are monodirectional and feature both the same architecture.

The bidirectional I/O line provides a way to automatically adapt the voltage difference between the MCU and the SIM card in both directions. In addition with the pullup resistor, an active pullup circuit (Figure 8, Q1 and Q2) provides a fast charge of the stray capacitance, yielding a rise time fully within the ISO7816 specifications.

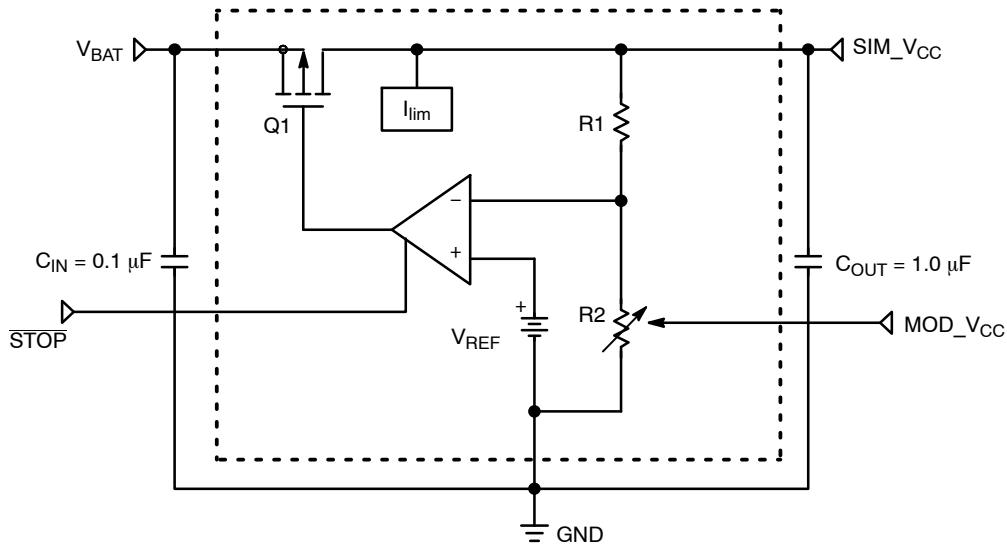

Figure 8. Simplified Block Diagram of the LDO Voltage Regulator

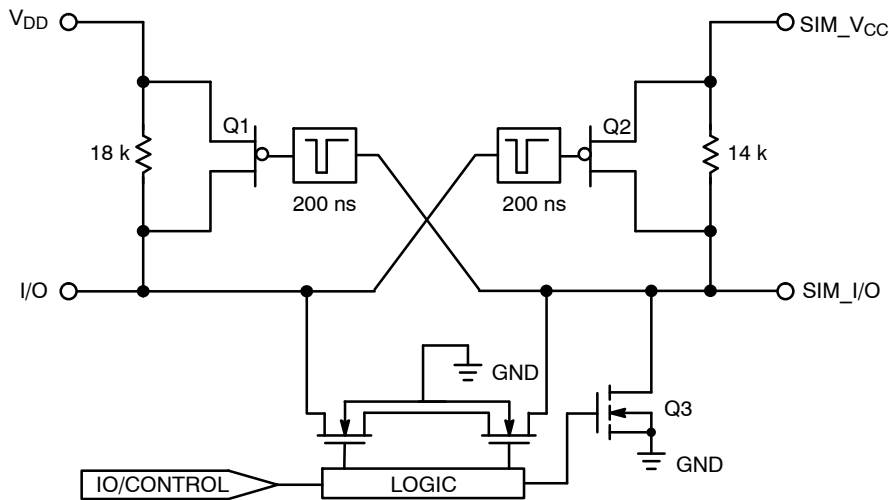

Figure 9. Basic I/O Line Interface

The typical waveform provided in Figure 10 shows how the accelerator operates. During the first 200 ns (typical), the slope of the rise time is solely a function of the pullup resistor associated with the stray capacitance. During this period, the PMOS devices are not activated since the input voltage is below their V_{gs} threshold. When the input slope crosses the V_{gsth} , the opposite one shot is activated, providing a low impedance to charge the capacitance, thus increasing the rise time as depicted in Figure 10. The same mechanism applies for the opposite side of the line to make sure the system is optimum.

INPUT SCHMITT TRIGGERS

All the Logic input pins (excepted I/O and SIM_I/O, See Figure 3) have built-in Schmitt trigger circuits to prevent the NCN4555 against uncontrolled operation. The typical dynamic characteristics of the related pins are depicted Figure 11.

The output signal is guaranteed to go High when the input voltage is above $0.7 \times V_{DD}$, and will go Low when the input voltage is below 0.4 V .

SHUTDOWN OPERATING

In order to save power or for other purpose required by the application it is possible to put the NCN4555 in a shutdown mode by setting Low the pin \overline{STOP} . On the other hand the device enters automatically in a shutdown mode when V_{DD} becomes lower than 1.1 V typically.

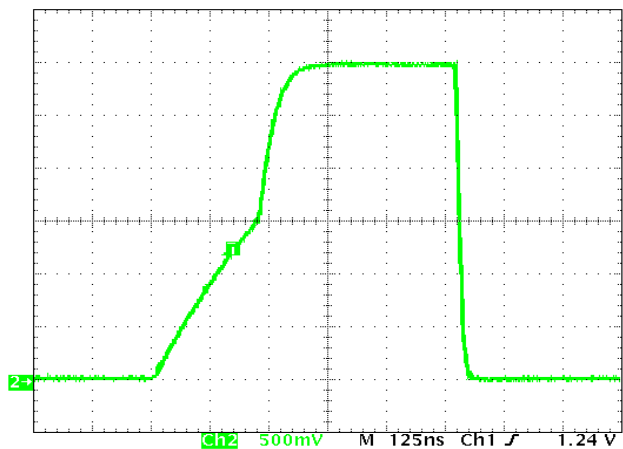

Figure 10. SIM_IO Typical Rise and Fall Times with Stray Capacitance > 30 pF (33 pF Capacitor Connected on the Board)

ESD PROTECTION

The NCN4555 SIM interface features an HBM ESD voltage protection in excess of 7 kV for all the SIM pins (SIM_IO, SIM_CLK, SIM_RST, SIM_VCC and GND). All the other pins (microcontroller side) sustain at least 2 kV. These values are guaranteed for the device in its full integrity without considering the external capacitors added to the circuit for a proper operating. Consequently in the operating conditions it is able to sustain much more than 7 kV on its SIM pins making it perfectly protected against electrostatic discharge well over the HBM ESD voltages required by the ISO7816 standard (4 kV).

PRINTED CIRCUIT BOARD LAYOUT

Careful layout routing will be applied to achieve a good and efficient operating of the device in its mobile or portable environment and fully exploit its performance.

The bypass capacitors have to be connected as close as possible to the device pins (SIM_VCC, V_{DD} or V_{BAT}) in order to reduce as much as possible parasitic behaviors (ripple and noise). It is recommended to use ceramic capacitors.

The exposed pad of the QFN-16 package will be connected to the ground as well as the unconnected pins (NC). A relatively large ground plane is recommended.

Figures 12 and 13 shows an example of PCB device implementation in an evaluation environment.

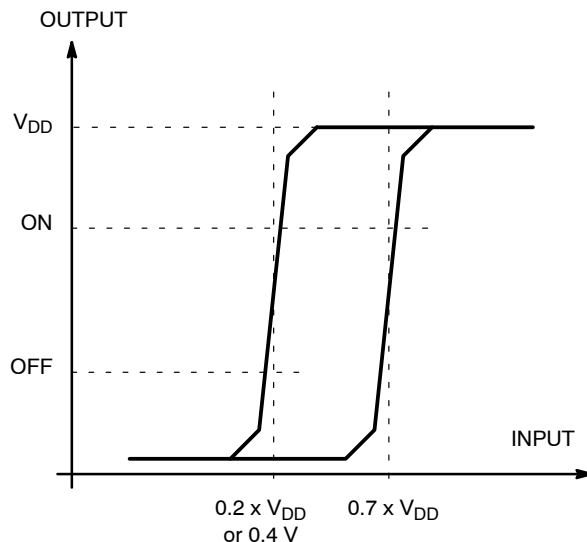

Figure 11. Typical Schmitt Trigger Characteristics

NCN4555

EVALUATION BOARD AND PCB GUIDELINES

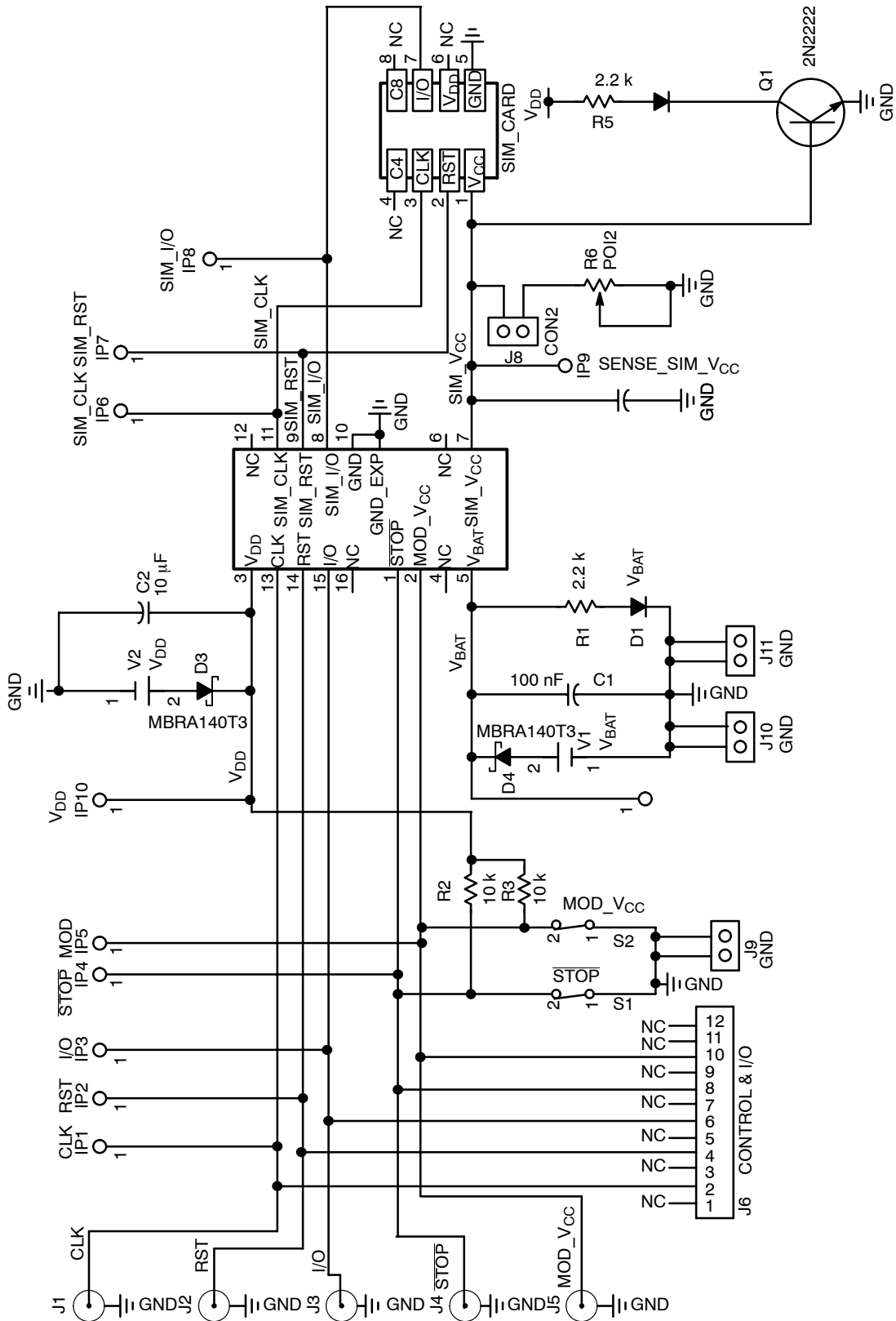

Figure 12. NCN4555 engineering test board schematic diagram

NCN4555

EVALUATION BOARD AND PCB GUIDELINES

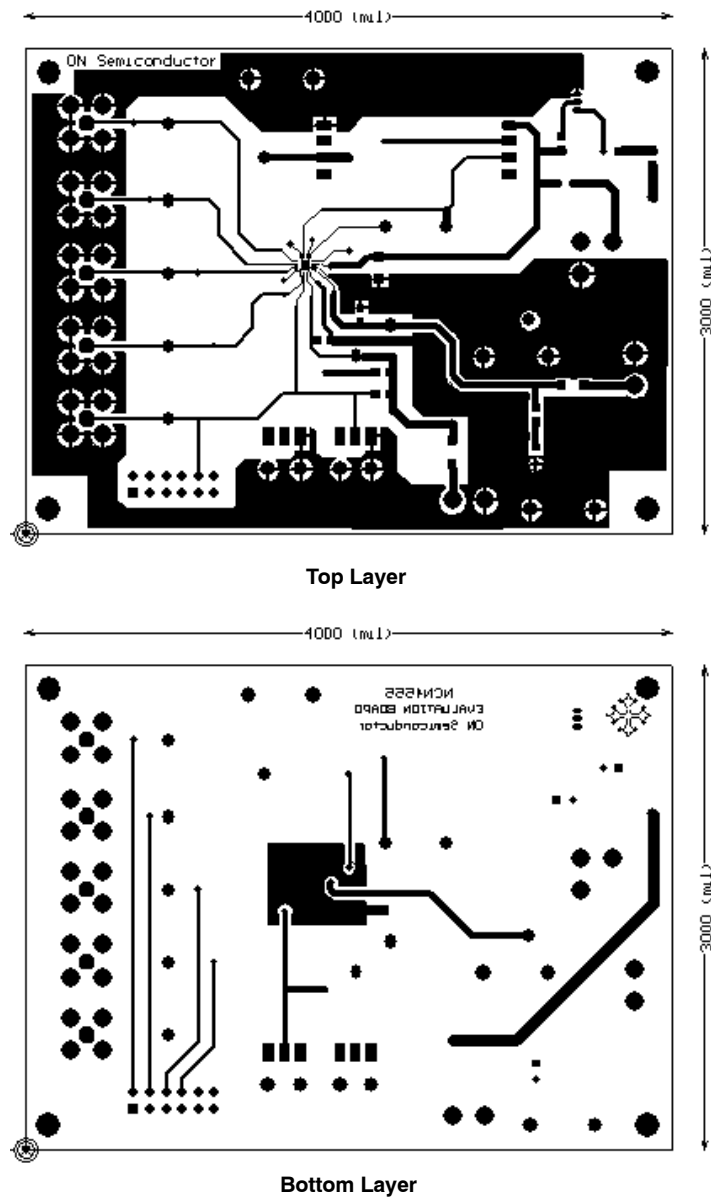
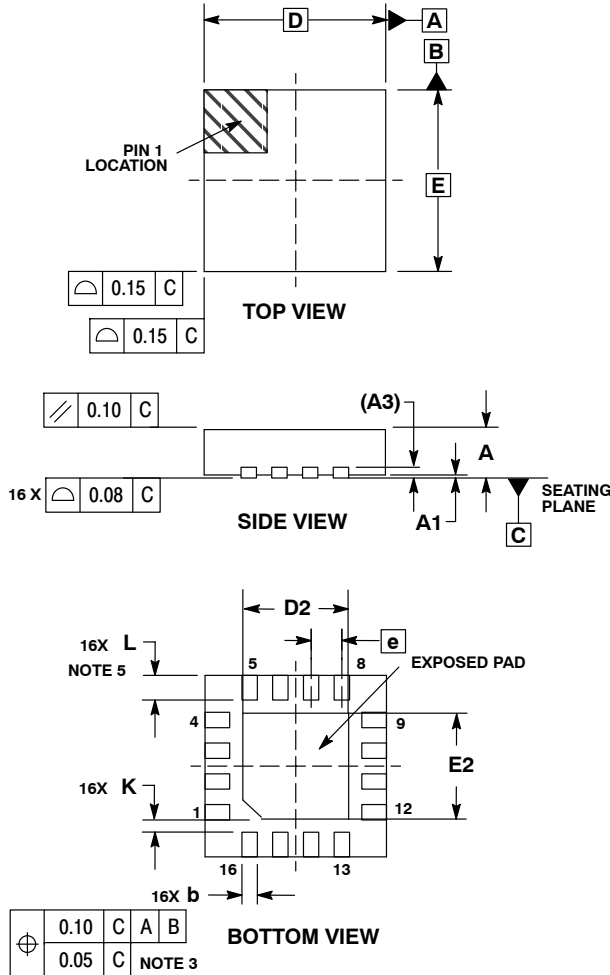

Figure 13. NCN4555 Printed Circuit Board Layout (Engineering board)

NCN4555

PACKAGE DIMENSIONS

QFN16 3x3x0.75mm, 0.5P
CASE 488AK-01
ISSUE O



NOTES:

1. DIMENSIONING AND TOLERANCING PER ASME Y14.5M, 1994.
2. CONTROLLING DIMENSION: MILLIMETERS.
3. DIMENSION b APPLIES TO PLATED TERMINAL AND IS MEASURED BETWEEN 0.25 AND 0.30 MM FROM TERMINAL.
4. COPLANARITY APPLIES TO THE EXPOSED PAD AS WELL AS THE TERMINALS.
5. L_{max} CONDITION CAN NOT VIOLATE 0.2 MM SPACING BETWEEN LEAD TIP AND FLAG.

DIM	MILLIMETERS	
	MIN	MAX
A	0.70	0.80
A1	0.00	0.05
A3	0.20 REF	
b	0.18	0.30
D	3.00 BSC	
D2	1.65	1.85
E	3.00 BSC	
E2	1.65	1.85
e	0.50 BSC	
K	0.20	---
L	0.30	0.50

ON Semiconductor and are registered trademarks of Semiconductor Components Industries, LLC (SCILLC). SCILLC reserves the right to make changes without further notice to any products herein. SCILLC makes no warranty, representation or guarantee regarding the suitability of its products for any particular purpose, nor does SCILLC assume any liability arising out of the application or use of any product or circuit, and specifically disclaims any and all liability, including without limitation special, consequential or incidental damages. "Typical" parameters which may be provided in SCILLC data sheets and/or specifications can and do vary in different applications and actual performance may vary over time. All operating parameters, including "Typicals" must be validated for each customer application by customer's technical experts. SCILLC does not convey any license under its patent rights nor the rights of others. SCILLC products are not designed, intended, or authorized for use as components in systems intended for surgical implant into the body, or other applications intended to support or sustain life, or for any other application in which the failure of the SCILLC product could create a situation where personal injury or death may occur. Should Buyer purchase or use SCILLC products for any such unintended or unauthorized application, Buyer shall indemnify and hold SCILLC and its officers, employees, subsidiaries, affiliates, and distributors harmless against all claims, costs, damages, and expenses, and reasonable attorney fees arising out of, directly or indirectly, any claim of personal injury or death associated with such unintended or unauthorized use, even if such claim alleges that SCILLC was negligent regarding the design or manufacture of the part. SCILLC is an Equal Opportunity/Affirmative Action Employer. This literature is subject to all applicable copyright laws and is not for resale in any manner.

PUBLICATION ORDERING INFORMATION

LITERATURE FULFILLMENT:
Literature Distribution Center for ON Semiconductor
P.O. Box 5163, Denver, Colorado 80217 USA
Phone: 303-675-2175 or 800-344-3860 Toll Free USA/Canada
Fax: 303-675-2176 or 800-344-3867 Toll Free USA/Canada
Email: orderlit@onsemi.com

N. American Technical Support: 800-282-9855 Toll Free
USA/Canada
Europe, Middle East and Africa Technical Support:
Phone: 421 33 790 2910
Japan Customer Focus Center
Phone: 81-3-5773-3850

ON Semiconductor Website: www.onsemi.com

Order Literature: <http://www.onsemi.com/orderlit>

For additional information, please contact your local Sales Representative

Looking for pricing, stock, or lifecycle information?

Click below to explore more details on WIN SOURCE:

- ⊖ [View NCN4555MNR2G on WIN SOURCE](#)
- ⊖ [ON Semiconductor Information](#)

Optimize Your Supply Chain with WIN SOURCE Solutions

- ✓ Global Sourcing Solution
- ✓ Obsolete Management
- ✓ Cost Control Management
- ✓ Shortage Management
- ✓ Alternative Solution
- ✓ Excess Inventory Management