



**THE DATASHEET OF
NC7SZ74K8X**



TinyLogic UHS D-Type, Flip-Flop with Preset and Clear

NC7SZ74

Description

The NC7SZ74 is a single, D-type, CMOS flip-flop with preset and clear from onsemi ultra high-speed series of TinyLogic. The device is fabricated with advanced CMOS technology to achieve ultra high speed with high output drive, while maintaining low static power dissipation over a very broad V_{CC} operating range of 1.65 V to 5.5 V V_{CC} . The inputs and outputs are high impedance when V_{CC} is 0 V. Inputs tolerate voltages up to 5.5 V, independent of V_{CC} operating voltage.

The signal level applied to the D input is transferred to the Q output during the positive-going transition of the CLK pulse.

Features

- Ultra-High Speed: t_{PD} 2.6 ns (Typical) into 50 pF at 5 V V_{CC}
- High Output Drive: ± 24 mA at 3 V V_{CC}
- Broad V_{CC} Operating Range: 1.65 V to 5.5 V
- Power Down High-Impedance Inputs/Outputs
- Over-Voltage Tolerance Inputs Facilitate 5 V to 3 V Translation
- Proprietary Noise/EMI Reduction Circuitry

CONNECTION DIAGRAM

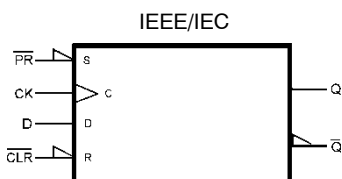
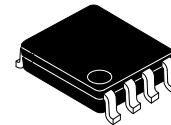

Figure 1. Logic Symbol



US8
CASE 846AN



UQFN8
1.6X1.6, 0.5P
CASE 523AY

MARKING DIAGRAMS

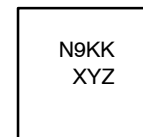
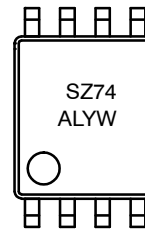

- SZ74, N9 = Specific Device Code
A = Assembly Site
L = Wafer Lot Number
YW = Assembly Start Wee
KK = 2-Digit Lot Run Traceability Code
XY = 2-Digit Date Code Format
Z = Assembly Plant Code

PIN CONFIGURATIONS

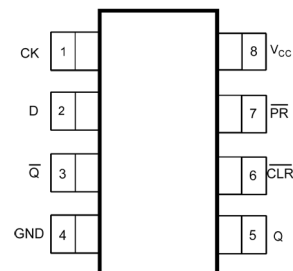

USB (Top View)

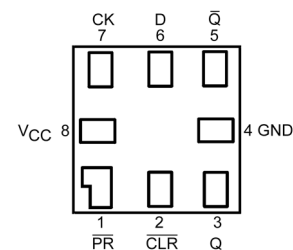

MicroPak™ (Top Through View)

ORDERING INFORMATION

See detailed ordering and shipping information on page 6 of this data sheet.

NC7SZ74

PIN DEFINITIONS

Pin # US8	Pin # MicroPak	Name	Description
1	7	CK	Clock Pulse Input
2	6	D	Data Input
3	5	\bar{Q}	Flip-Flop Output
4	4	GND	Ground
5	3	Q	Flip-Flop Output
6	2	$\overline{\text{CLR}}$	Direct Clear Input
7	1	$\overline{\text{PR}}$	Direct Preset Input
8	8	V _{CC}	Supply Voltage

FUNCTION TABLE

Inputs				Output		Function
CLR	PR	D	CK	Q	\bar{Q}	
L	H	X	X	L	H	Clear
H	L	X	X	H	L	Preset
L	L	X	X	H	H	
H	H	L	↑	L	H	
H	H	H	↑	H	L	
H	H	X	↓	Q _n	\bar{Q}_n	No Change

H = HIGH Logic Level

Q_n = No change in data

X = Immaterial

↓ = Falling Edge

L = LOW Logic Level

Z = High Impedance

↑ = Rising Edge

ABSOLUTE MAXIMUM RATINGS

Symbol	Parameter	Min	Max	Unit
V _{CC}	Supply Voltage	-0.5	6.5	V
V _{IN}	DC Input Voltage	-0.5	6.5	V
V _{OUT}	DC Output Voltage	-0.5	6.5	V
I _{IK}	DC Input Diode Current	-	-50	mA
I _{OK}	DC Output Diode Current	-	-50	mA
I _{OUT}	DC Output Source/Sink Current	-	±50	mA
I _{CC} or I _{GND}	DC V _{CC} or Ground Current	-	±50	mA
T _{STG}	Storage Temperature Range	-65	+150	°C
T _J	Junction Temperature Under Bias	-	+150	°C
T _L	Junction Lead Temperature (Soldering, 10 Seconds)	-	+260	°C
P _D	Power Dissipation in Still Air	-	500 539	mW
ESD	Human Body Model: JEDEC:JESD22-A114	-	4000	V
	Charge Device Model: JEDEC:JESD22-C101	-	2000	

Stresses exceeding those listed in the Maximum Ratings table may damage the device. If any of these limits are exceeded, device functionality should not be assumed, damage may occur and reliability may be affected.

NC7SZ74

RECOMMENDED OPERATING CONDITIONS

Symbol	Parameter	Conditions	Min	Max	Unit
V _{CC}	Supply Voltage Operating		1.65	5.50	V
	Supply Voltage Data Retention		1.50	5.50	
V _{IN}	Input Voltage		0	5.5	V
V _{OUT}	Output Voltage	Active State	0	V _{CC}	V
		3-State	0	5.5	
t _r , t _f	Input Rise and Fall Times	V _{CC} = 1.8 V, 2.5 V ±0.2 V	0	20	ns/V
		V _{CC} = 3.3 V ±0.3 V	0	10	
		V _{CC} = 5.0 V ±0.5 V	0	5	
T _A	Operating Temperature		-40	+85	°C
θ _{JA}	Thermal Resistance	US8		250	°C/W
		MicroPak-8		232	

Functional operation above the stresses listed in the Recommended Operating Ranges is not implied. Extended exposure to stresses beyond the Recommended Operating Ranges limits may affect device reliability.

NOTE: Unused inputs must be held HIGH or LOW. They may not float.

DC ELECTRICAL CHARACTERISTICS

Symbol	Parameter	V _{CC}	Conditions	T _A = +25°C			T _A = -40 to +85°C		Units
				Min	Typ	Max	Min	Max	
V _{IH}	HIGH Level Control Input Voltage	1.65 to 1.95		0.65 V _{CC}			0.65 V _{CC}		V
		2.30 to 5.50		0.70 V _{CC}			0.70 V _{CC}		
V _{IL}	LOW Level Control Input Voltage	1.65 to 1.95				0.35 V _{CC}		0.35 V _{CC}	V
		2.30 to 5.50				0.30 V _{CC}		0.30 V _{CC}	
V _{OH}	HIGH Level Output Voltage	1.65	V _{IN} = V _{IH} , I _{OH} = -100 μA	1.55	1.65		1.55		V
		2.30		2.20	2.30		2.20		
		3.00		2.90	3.00		2.90		
		4.50		4.40	4.50		4.40		
		1.65	I _{OH} = -4 mA	1.29	1.52		1.29		
		2.30		1.90	2.15		1.90		
		3.00		2.40	2.80		2.40		
		3.00		2.30	2.68		2.30		
4.50	I _{OH} = -32 mA	3.80	4.20		3.80				
V _{OL}	LOW Level Control Output Voltage	1.65	V _{IN} = V _{IH} , I _{OL} = 100 μA			0.10		0.10	V
		2.30				0.10		0.10	
		3.00				0.10		0.10	
		4.50				0.10		0.10	
		1.65	I _{OL} = 4 mA		0.10	0.24		0.24	
		2.30		0.10	0.30		0.30		
		3.00		0.15	0.40		0.40		
		3.00		0.22	0.55		0.55		
		4.50		0.22	0.55		0.55		
		4.50		I _{OL} = 32 mA		0.22	0.55		
I _{IN}	Input Leakage Current	1.65 to 5.5	0 ≤ V _{IN} ≤ 5.5 V			±0.1		±1.0	μA
I _{OFF}	Power Off Leakage Current	0	V _{IN} or V _{OUT} = 5.5 V			1		10	μA
I _{CC}	Quiescent Supply Current	1.65 to 5.50	V _{IN} = 5.5 V, GND			1		10	μA

NC7SZ74

AC ELECTRICAL CHARACTERISTICS

Symbol	Parameter	V _{CC}	Conditions	T _A = +25°C			T _A = -40 to +85°C		Units	Figure
				Min	Typ	Max	Min	Max		
f _{MAX}	Maximum Clock Frequency	1.80 ±0.15	C _L = 15 pF, R _D = 1 MΩ, S ₁ = Open	75			75		MHz	Figure 4 Figure 8
		2.50 ±0.20		150			150			
		3.30 ±0.30		200			200			
		5.00 ±0.50		250			250			
		3.30 ±0.50	C _L = 50 pF, R _D = 500 Ω, S ₁ = Open	175			175			
		5.00 ±0.50		200			200			
t _{PLH} , t _{PHL}	Propagation Delay CK to Q, \bar{Q}	1.80 ±0.15	C _L = 15 pF, R _D = 1 MΩ, S ₁ = Open		6.5	12.5		13.0	ns	Figure 4 Figure 6
		2.50 ±0.20			3.8	7.5		8.0		
		3.30 ±0.30			2.8	6.5		7.0		
		5.00 ±0.50			2.2	4.5		5.0		
		3.30 ±0.30	C _L = 50 pF, R _D = 500 Ω, S ₁ = Open		3.4	7.0		7.5		
		5.00 ±0.50			2.6	5.0		5.5		
t _{PLH} , t _{PHL}	Propagation Delay CLR, PR to Q, \bar{Q}	1.80 ±0.15	C _L = 15 pF, R _L = 1 MΩ, S ₁ = Open		6.5	14.0		14.5	ns	Figure 4 Figure 6
		2.50 ±0.20			3.8	9.0		9.5		
		3.30 ±0.30			2.8	6.5		7.0		
		5.00 ±0.50			2.2	5.0		5.5		
		3.30 ±0.30	C _L = 50 pF, R _D = 500 Ω, S ₁ = Open		3.4	7.0		7.5		
		5.00 ±0.50			2.6	5.0		5.5		
t _S	Setup Time CK to D	1.80 ±0.15	C _L = 15 pF, R _L = 1 MΩ, S ₁ = Open	6.5			6.5		ns	Figure 4 Figure 7
		2.50 ±0.20		3.5			3.5			
		3.30 ±0.30		2.0			2.0			
		5.00 ±0.50		1.5			1.5			
		3.30 ±0.30	C _L = 50 pF, R _D = 500 Ω, S ₁ = Open	2.0			2.0			
		5.00 ±0.50		1.5			1.5			
t _H	Hold Time, CK to D	1.80 ±0.15	C _L = 15 pF, R _L = 1 MΩ, S ₁ = Open	0.5			0.5		ns	Figure 4 Figure 7
		2.50 ±0.20		0.5			0.5			
		3.30 ±0.30		0.5			0.5			
		5.00 ±0.50		0.5			0.5			
		3.30 ±0.30	C _L = 50 pF, R _D = 500 Ω, S ₁ = Open	0.5			0.5			
		5.00 ±0.50		0.5			0.5			
t _W	Pulse Width, CK, PR, CLR	1.80 ±0.15	C _L = 15 pF, R _L = 1 MΩ, S ₁ = Open	6.0			6.0		ns	Figure 4 Figure 8
		2.50 ±0.20		4.0			4.0			
		3.30 ±0.30		3.0			3.0			
		5.00 ±0.50		2.0			2.0			
		3.30 ±0.30	C _L = 50 pF, R _D = 500 Ω, S ₁ = Open	3.0			3.0			
		5.00 ±0.50		2.0			2.0			
t _{REC}	Recover Time CLR, PR to CK	1.80 ±0.15	C _L = 15 pF, R _L = 1 MΩ, S ₁ = Open	8.0			8.0		ns	Figure 7
		2.50 ±0.20		4.5			4.5			
		3.30 ±0.30		3.0			3.0			
		5.00 ±0.50		3.0			3.0			
		3.30 ±0.30	C _L = 50 pF, R _D = 500 Ω, S ₁ = Open	3.0			3.0			
		5.00 ±0.50		3.0			3.0			

NC7SZ74

AC ELECTRICAL CHARACTERISTICS (continued)

Symbol	Parameter	V _{CC}	Conditions	T _A = +25°C			T _A = -40 to +85°C		Units	Figure
				Min	Typ	Max	Min	Max		
C _{IN}	Input Capacitance	0			3				pF	
C _{OUT}	Output Capacitance	0			4				pF	
C _{PD}	Power Dissipation Capacitance (Note 1)	3.30			10				pF	
		5.00			12					

1. C_{PD} is defined as the value of the internal equivalent capacitance which is derived from dynamic operating current consumption (I_{CCD}) at no output loading and operating at 50% duty cycle. C_{PD} is related to I_{CCD} dynamic operating current by the expression: I_{CCD} = (C_{PD})(V_{CC})(f_{IN}) + (I_{CCstatic}).

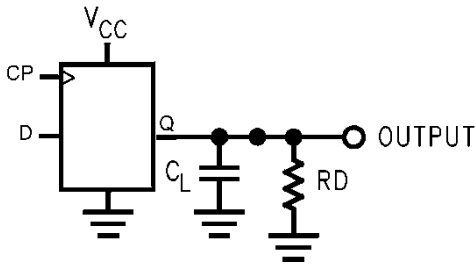

2. C_L includes load and stray capacitance.
Input PRR = 1.0 MHz t_w = 500 ns.

Figure 2. AC Test Circuit

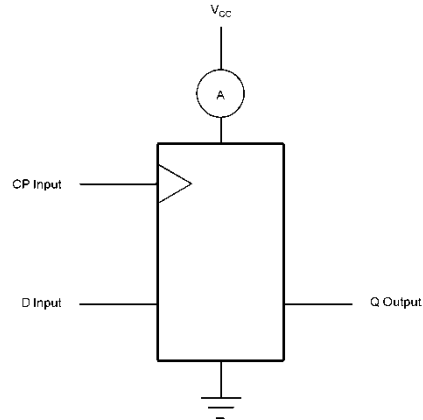

3. CP input = AC Waveforms t_r = t_f = 2.5 ns.
4. CP input PRR = 10 MHz; Duty Cycle = 50%.
5. D input PRR = 5 MHz; Duty Cycle = 50%.

Figure 3. AC Test Circuit

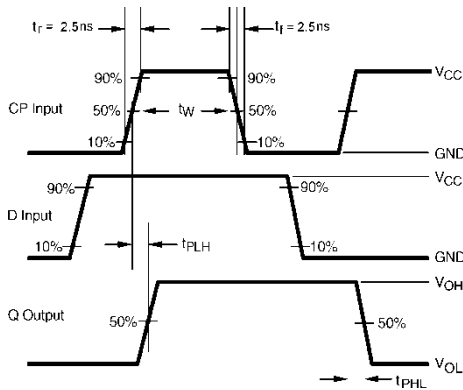

Figure 4. AC Waveforms

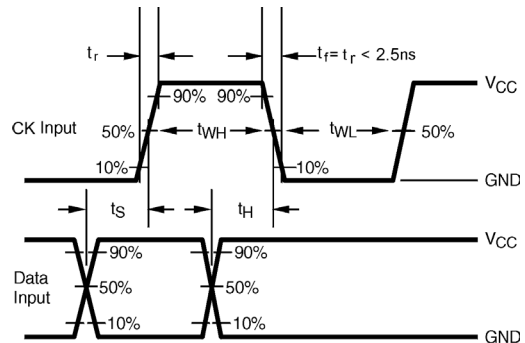

Figure 5. AC Waveforms

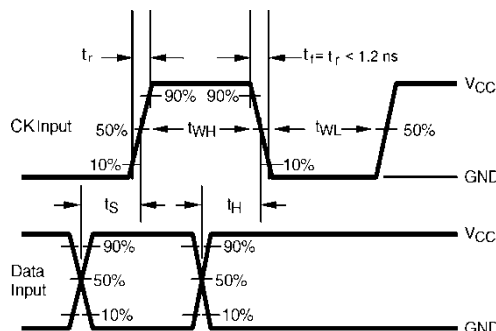

Figure 6. AC Waveforms

NC7SZ74

ORDERING INFORMATION

Part Number	Top Mark	Package	Packing Method†
NC7SZ74K8X	SZ74	8-Lead US8, JEDEC MO-187, Variation CA 3.1mm Wide	3000 Units on Tape & Reel
NC7SZ74K8X-L22236	SZ74	8-Lead US8, JEDEC MO-187, Variation CA 3.1mm Wide	3000 Units on Tape & Reel
NC7SZ74L8X	N9	8-Lead MicroPak, 1.6 mm Wide	5000 Units on Tape & Reel
NC7SZ74L8X-L22185	N9	8-Lead MicroPak, 1.6 mm Wide	5000 Units on Tape & Reel

†For information on tape and reel specifications, including part orientation and tape sizes, please refer to our Tape and Reel Packaging Specifications Brochure, BRD8011/D

MicroPak is a trademark of Semiconductor Components Industries, LLC dba "onsemi" or its affiliates and/or subsidiaries in the United States and/or other countries.

UQFN8 1.6X1.6, 0.5P
CASE 523AY
ISSUE O

DATE 31 AUG 2016

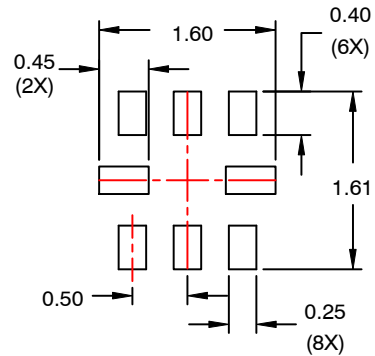
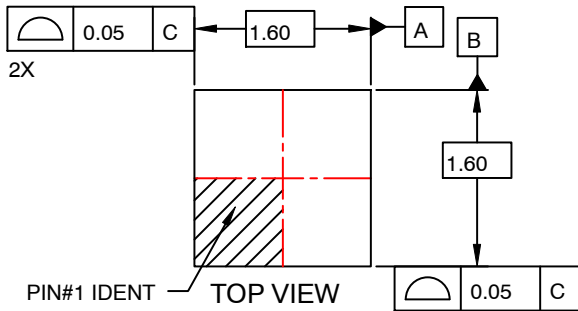

**RECOMMENDED
LAND PATTERN**

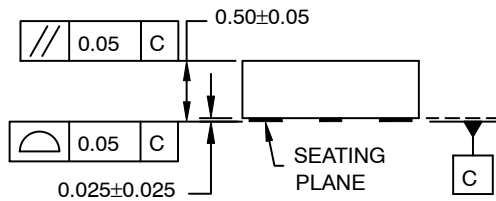

SIDE VIEW

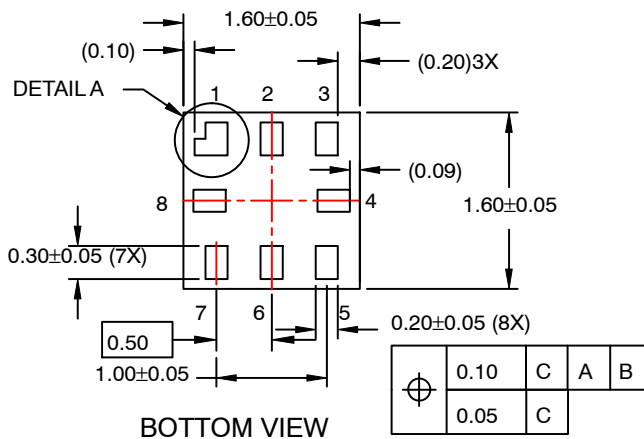

BOTTOM VIEW

NOTES:

- A. PACKAGE CONFORMS TO JEDEC MO-255 VARIATION UAAD.
- B. DIMENSIONS ARE IN MILLIMETERS.
- C. DIMENSIONS AND TOLERANCES PER ASME Y14.5M, 2009.
- D. LAND PATTERN RECOMMENDATION IS EXISTING INDUSTRY LAND PATTERN.

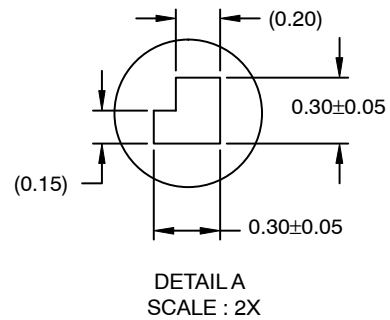

**DETAIL A
SCALE : 2X**

DOCUMENT NUMBER:	98AON13591G	Electronic versions are uncontrolled except when accessed directly from the Document Repository. Printed versions are uncontrolled except when stamped "CONTROLLED COPY" in red.
DESCRIPTION:	UQFN8 1.6X1.6, 0.5P	PAGE 1 OF 1

ON Semiconductor and **ON** are trademarks of Semiconductor Components Industries, LLC dba ON Semiconductor or its subsidiaries in the United States and/or other countries. ON Semiconductor reserves the right to make changes without further notice to any products herein. ON Semiconductor makes no warranty, representation or guarantee regarding the suitability of its products for any particular purpose, nor does ON Semiconductor assume any liability arising out of the application or use of any product or circuit, and specifically disclaims any and all liability, including without limitation special, consequential or incidental damages. ON Semiconductor does not convey any license under its patent rights nor the rights of others.

MECHANICAL CASE OUTLINE
PACKAGE DIMENSIONS

ON Semiconductor®



US8
CASE 846AN
ISSUE O

DATE 31 DEC 2016

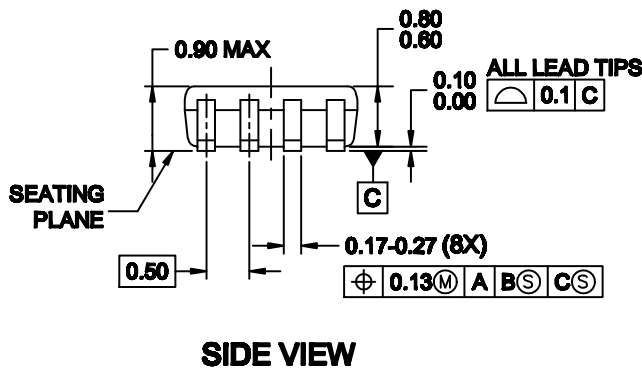
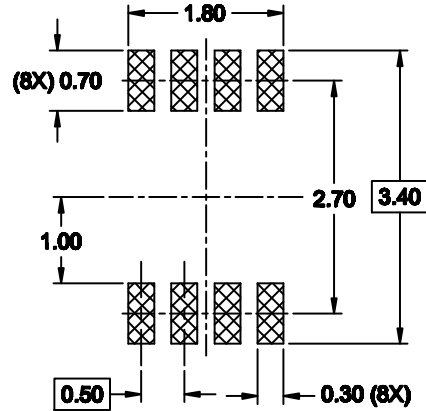

NOTES:

- A. CONFORMS TO JEDEC REGISTRATION MO-187
- B. DIMENSIONS ARE IN MILLIMETERS.
- C. DIMENSIONS ARE EXCLUSIVE OF BURRS, MOLD FLASH, AND TIE BAR EXTRUSIONS.
- D. DIMENSIONS AND TOLERANCES PER ANSI Y14.5M, 1994.

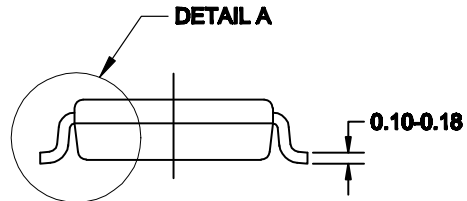

DOCUMENT NUMBER:	98AON13778G	Electronic versions are uncontrolled except when accessed directly from the Document Repository. Printed versions are uncontrolled except when stamped "CONTROLLED COPY" in red.
DESCRIPTION:	US8	PAGE 1 OF 1

ON Semiconductor and are trademarks of Semiconductor Components Industries, LLC dba ON Semiconductor or its subsidiaries in the United States and/or other countries. ON Semiconductor reserves the right to make changes without further notice to any products herein. ON Semiconductor makes no warranty, representation or guarantee regarding the suitability of its products for any particular purpose, nor does ON Semiconductor assume any liability arising out of the application or use of any product or circuit, and specifically disclaims any and all liability, including without limitation special, consequential or incidental damages. ON Semiconductor does not convey any license under its patent rights nor the rights of others.

onsemi, **Onsemi**, and other names, marks, and brands are registered and/or common law trademarks of Semiconductor Components Industries, LLC dba "**onsemi**" or its affiliates and/or subsidiaries in the United States and/or other countries. **onsemi** owns the rights to a number of patents, trademarks, copyrights, trade secrets, and other intellectual property. A listing of **onsemi**'s product/patent coverage may be accessed at www.onsemi.com/site/pdf/Patent-Marking.pdf. **onsemi** reserves the right to make changes at any time to any products or information herein, without notice. The information herein is provided "as-is" and **onsemi** makes no warranty, representation or guarantee regarding the accuracy of the information, product features, availability, functionality, or suitability of its products for any particular purpose, nor does **onsemi** assume any liability arising out of the application or use of any product or circuit, and specifically disclaims any and all liability, including without limitation special, consequential or incidental damages. Buyer is responsible for its products and applications using **onsemi** products, including compliance with all laws, regulations and safety requirements or standards, regardless of any support or applications information provided by **onsemi**. "Typical" parameters which may be provided in **onsemi** data sheets and/or specifications can and do vary in different applications and actual performance may vary over time. All operating parameters, including "Typicals" must be validated for each customer application by customer's technical experts. **onsemi** does not convey any license under any of its intellectual property rights nor the rights of others. **onsemi** products are not designed, intended, or authorized for use as a critical component in life support systems or any FDA Class 3 medical devices or medical devices with a same or similar classification in a foreign jurisdiction or any devices intended for implantation in the human body. Should Buyer purchase or use **onsemi** products for any such unintended or unauthorized application, Buyer shall indemnify and hold **onsemi** and its officers, employees, subsidiaries, affiliates, and distributors harmless against all claims, costs, damages, and expenses, and reasonable attorney fees arising out of, directly or indirectly, any claim of personal injury or death associated with such unintended or unauthorized use, even if such claim alleges that **onsemi** was negligent regarding the design or manufacture of the part. **onsemi** is an Equal Opportunity/Affirmative Action Employer. This literature is subject to all applicable copyright laws and is not for resale in any manner.

ADDITIONAL INFORMATION

TECHNICAL PUBLICATIONS:

Technical Library: www.onsemi.com/design/resources/technical-documentation
onsemi Website: www.onsemi.com

ONLINE SUPPORT: www.onsemi.com/support

For additional information, please contact your local Sales Representative at www.onsemi.com/support/sales

Looking for pricing, stock, or lifecycle information?

Click below to explore more details on WIN SOURCE:

- ⊖ [View NC7SZ74K8X on WIN SOURCE](#)
- ⊖ [Fairchild/ON Semiconductor Information](#)

Optimize Your Supply Chain with WIN SOURCE Solutions

- ✓ Global Sourcing Solution
- ✓ Obsolete Management
- ✓ Cost Control Management
- ✓ Shortage Management
- ✓ Alternative Solution
- ✓ Excess Inventory Management