



# NB7V58M

## 1.8 V / 2.5 V / 3.3 V Differential 2:1 Clock / Data Multiplexer / Translator with CML Outputs

### Multi-Level Inputs w/ Internal Termination

#### Description

The NB7V58M is a high performance differential 2-to-1 Clock or Data multiplexer. The differential inputs incorporate internal 50  $\Omega$  termination resistors that are accessed through the VT pin. This feature allows the NB7V58M to accept various logic level standards, such as LVPECL, CML or LVDS.

The NB7V58M produces minimal Clock or Data jitter operating up to 7 GHz or 10.7 Gb/s, respectively. As such, the NB7V58M is ideal for SONET, GigE, Fiber Channel, Backplane and other Clock/Data distribution applications.

The 16 mA differential CML outputs provide matching internal 50  $\Omega$  terminations and 400 mV output swings when externally terminated with a 50  $\Omega$  resistor to  $V_{CC}$ .

The NB7V58M is offered in a low profile 3 mm x 3 mm 16-pin QFN package and is a member of the GigaComm™ family of high performance Clock / Data products. For applications that require equalization, the pin-compatible NB7VQ58M is also available. Application notes, models, and support documentation are available at [www.onsemi.com](http://www.onsemi.com).

#### Features

- Maximum Input Data Rate > 10.7 Gb/s
- Data Dependent Jitter < 10 ps
- Maximum Input Clock Frequency > 7 GHz
- Random Clock Jitter < 0.8 ps RMS
- 180 ps Typical Propagation Delay
- 35 ps Typical Rise and Fall Times
- Differential CML Outputs, 400 mV Peak-to-Peak, Typical
- Operating Range:  $V_{CC} = 1.71$  V to 3.6 V with GND = 0 V
- Internal 50  $\Omega$  Input Termination Resistors
- QFN-16 Package, 3 mm x 3 mm
- -40°C to +85°C Ambient Operating Temperature
- This is a Pb-Free Device



ON Semiconductor®

<http://onsemi.com>

#### MARKING DIAGRAM\*

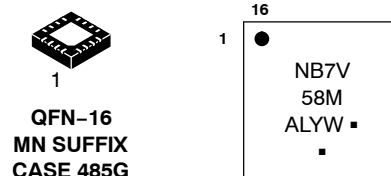

A = Assembly Location  
L = Wafer Lot  
Y = Year  
W = Work Week  
■ = Pb-Free Package

(Note: Microdot may be in either location)

\*For additional marking information, refer to Application Note AND8002/D.

#### SIMPLIFIED BLOCK DIAGRAM

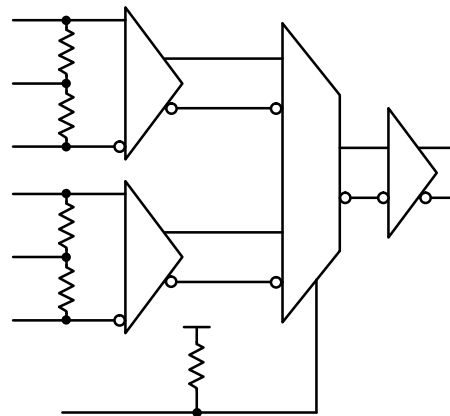

#### ORDERING INFORMATION

See detailed ordering and shipping information in the package dimensions section on page 7 of this data sheet.

# NB7V58M

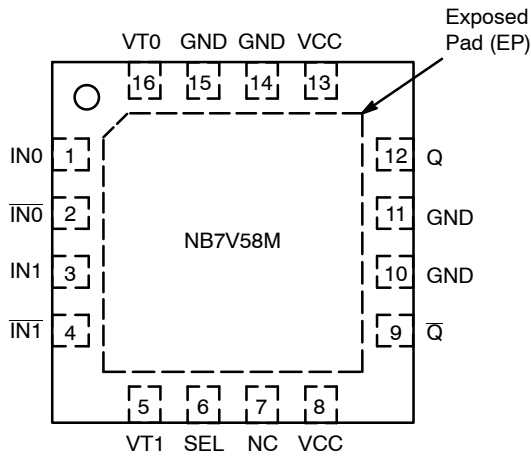

Figure 1. Pin Configuration (Top View)

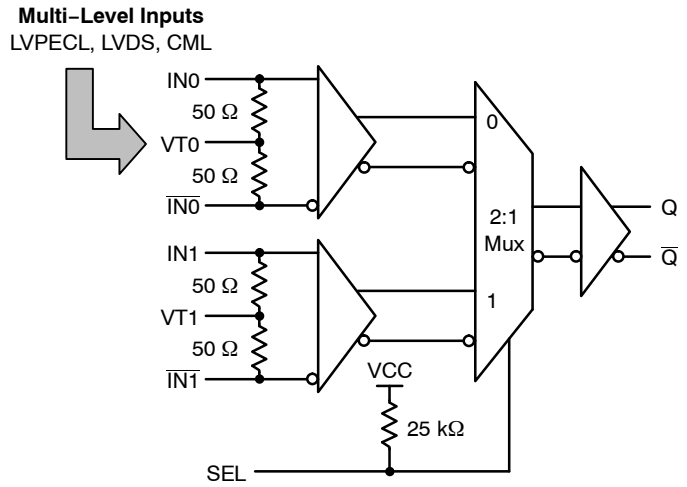

Figure 2. Detailed Block Diagram

Table 1. SElect FUNCTION TRUTH TABLE

SEL	Q	$\bar{Q}$
L	IN0	$\bar{IN0}$
H	IN1	$\bar{IN1}$

Table 2. PIN DESCRIPTION

Pin	Name	I/O	Description
1	IN0	LVPECL, CML, LVDS Input	Noninverted Differential Input (Note 1)
2	$\bar{IN0}$	LVPECL, CML, LVDS Input	Inverted Differential Input (Note 1)
3	IN1	LVPECL, CML, LVDS Input	Noninverted Differential Input (Note 1)
4	$\bar{IN1}$	LVPECL, CML, LVDS Input	Inverted Differential Input (Note 1)
5	VT1	-	Internal 50 $\Omega$ Termination Pin for IN1/ $\bar{IN1}$
6	SEL	LVTTTL/LVCMOS Input	SEL Input. Low for IN0 inputs, high for IN1 inputs. (Note 1) Pin will default HIGH when left open (has internal pull-up resistor)
7	NC	-	No Connect
8	VCC	-	Positive Supply Voltage (Note 2)
9	$\bar{Q}$	CML Output	Inverted Differential Output
10	GND	-	Negative Supply Voltage
11	GND	-	Negative Supply Voltage
12	Q	CML Output	Noninverted Differential Output
13	VCC	-	Positive Supply Voltage (Note 2)
14	GND	-	Negative Supply Voltage
15	GND	-	Negative Supply Voltage
16	VT0	-	Internal 50 $\Omega$ Termination Pin for IN0/ $\bar{IN0}$
-	EP	-	The Exposed Pad (EP) on the QFN-16 package bottom is thermally connected to the die for improved heat transfer out of package. The exposed pad must be attached to a heat-sinking conduit. The pad is electrically connected to the die, and must be electrically and thermally connected to GND on the PC board.

1. In the differential configuration when the input termination pins (VT0, VT1) are connected to a common termination voltage or left open, and if no signal is applied on IN0/ $\bar{IN0}$ , IN1/ $\bar{IN1}$  inputs, then the device will be susceptible to self-oscillation. Q/ $\bar{Q}$  outputs have internal 50  $\Omega$  source termination resistors.
2. All VCC and GND pins must be externally connected to a power supply for proper operation.

# NB7V58M

**Table 3. ATTRIBUTES**

Characteristics		Value
ESD Protection	Human Body Model Machine Model	> 2 kV > 200 V
R <sub>PU</sub> – SEL Input Pull-up Resistor		25 kΩ
Moisture Sensitivity (Note 3)	QFN-16	Level 1
Flammability Rating	Oxygen Index: 28 to 34	UL 94 V-0 @ 0.125 in
Transistor Count		312
Meets or exceeds JEDEC Spec EIA/JESD78 IC Latchup Test		

3. For additional information, see Application Note AND8003/D.

**Table 4. MAXIMUM RATINGS**

Symbol	Parameter	Condition 1	Condition 2	Rating	Unit
V <sub>CC</sub>	Positive Power Supply	GND = 0 V		4.0	V
V <sub>IN</sub>	Positive Input Voltage	GND = 0 V		-0.5 to V <sub>CC</sub> +0.5	V
V <sub>INPP</sub>	Differential Input Voltage  I <sub>Nn</sub> – I <sub>Nn</sub>			1.89	V
I <sub>OUT</sub>	Output Current	Continuous Surge		34 40	mA
I <sub>IN</sub>	Input Current Through R <sub>T</sub> (50 Ω Resistor)			± 40	mA
T <sub>A</sub>	Operating Temperature Range			-40 to +85	°C
T <sub>stg</sub>	Storage Temperature Range			-65 to +150	°C
θ <sub>JA</sub>	Thermal Resistance (Junction-to-Ambient) (Note 4)	0 LFPM 500 LFPM	QFN-16 QFN-16	42 35	°C/W
θ <sub>JC</sub>	Thermal Resistance (Junction-to-Case) (Note 4)		QFN-16	4	°C/W
T <sub>sol</sub>	Wave Solder Pb-Free			265	°C

Stresses exceeding Maximum Ratings may damage the device. Maximum Ratings are stress ratings only. Functional operation above the Recommended Operating Conditions is not implied. Extended exposure to stresses above the Recommended Operating Conditions may affect device reliability.

4. JEDEC standard multilayer board – 2S2P (2 signal, 2 power) with 8 filled thermal vias under exposed pad.

# NB7V58M

**Table 5. DC CHARACTERISTICS POSITIVE CML OUTPUT** ( $V_{CC} = 1.71\text{ V to }3.6\text{ V}$ ;  $GND = 0\text{ V}$ ;  $T_A = -40^\circ\text{C to }85^\circ\text{C}$ ) (Note 5)

Symbol	Characteristic	Min	Typ	Max	Unit
--------	----------------	-----	-----	-----	------

## POWER SUPPLY CURRENT

$I_{CC}$	Power Supply Current (Inputs and Outputs Open)		100	150	mA
----------	--	--	-----	-----	----

## CML OUTPUTS (Note 6)

$V_{OH}$	Output HIGH Voltage	$V_{CC} - 30$ 3270 $V_{CC} = 2.5\text{ V}$ 2470 $V_{CC} = 1.8\text{ V}$ 1770	$V_{CC} - 5$ 3295 2495 1795	$V_{CC}$ 3300 2500 1800	mV
$V_{OL}$	Output LOW Voltage	$V_{CC} - 500$ 2800 $V_{CC} = 2.5\text{ V}$ 2000 $V_{CC} = 1.8\text{ V}$ 1300	$V_{CC} - 400$ 2900 2100 1400	$V_{CC} - 300$ 3000 2200 1500	mV

## DIFFERENTIAL INPUTS DRIVEN SINGLE-ENDED (Note 7) (Figures 6 & 8)

$V_{th}$	Input Threshold Reference Voltage Range (Note 8)	1050		$V_{CC} - 100$	mV
$V_{IH}$	Single-ended Input HIGH Voltage	$V_{th} + 100$		$V_{CC}$	mV
$V_{IL}$	Single-ended Input LOW Voltage	GND		$V_{th} - 100$	mV
$V_{ISE}$	Single-ended Input Voltage ( $V_{IH} - V_{IL}$ )	200		1200	mV

## DIFFERENTIAL IN0/IN0, IN1/IN1, INPUTS DRIVEN DIFFERENTIALLY (Figures 6 & 9) (Note 9)

$V_{IHD}$	Differential Input HIGH Voltage	1100		$V_{CC}$	mV
$V_{ILD}$	Differential Input LOW Voltage	GND		$V_{CC} - 100$	mV
$V_{ID}$	Differential Input Voltage ( $V_{IHD} - V_{ILD}$ )	100		1200	mV
$V_{CMR}$	Input Common Mode Range (Differential Configuration, Note 10) (Figure 10)	1050		$V_{CC} - 50$	mV
$I_{IH}$	Input HIGH Current (VTn Open)	-150		150	$\mu\text{A}$
$I_{IL}$	Input LOW Current (VTn Open)	-150		150	$\mu\text{A}$

## CONTROL INPUT (SEL)

$V_{IH}$	Input HIGH Voltage	$V_{CC} \times 0.65$		$V_{CC}$	mV
$V_{IL}$	Input LOW Voltage	GND		$V_{CC} \times 0.35$	mV
$I_{IH}$	Input HIGH Current	-150		+150	$\mu\text{A}$
$I_{IL}$	Input LOW Current	-200		+200	$\mu\text{A}$

## TERMINATION RESISTORS

$R_{TIN}$	Internal Input Termination Resistor	45	50	55	$\Omega$
$R_{TOUT}$	Internal Output Termination Resistor	45	50	55	$\Omega$

NOTE: Device will meet the specifications after thermal equilibrium has been established when mounted in a test socket or printed circuit board with maintained transverse airflow greater than 500 lfm. Electrical parameters are guaranteed only over the declared operating temperature range. Functional operation of the device exceeding these conditions is not implied. Device specification limit values are applied individually under normal operating conditions and not valid simultaneously.

- Input and output parameters vary 1:1 with  $V_{CC}$ .
- CML outputs loaded with  $50\ \Omega$  to  $V_{CC}$  for proper operation.
- $V_{th}$ ,  $V_{IH}$ ,  $V_{IL}$  and  $V_{ISE}$  parameters must be complied with simultaneously.
- $V_{th}$  is applied to the complementary input when operating in single-ended mode.
- $V_{IHD}$ ,  $V_{ILD}$ ,  $V_{ID}$  and  $V_{CMR}$  parameters must be complied with simultaneously.
- $V_{CMR}$  min varies 1:1 with GND,  $V_{CMR}$  max varies 1:1 with  $V_{CC}$ . The  $V_{CMR}$  range is referenced to the most positive side of the differential input signal.

# NB7V58M

**Table 6. AC CHARACTERISTICS** ( $V_{CC} = 1.71\text{ V to }3.6\text{ V}$ ;  $GND = 0\text{ V}$ ;  $T_A = -40^\circ\text{C to }85^\circ\text{C}$ ) (Note 11)

Symbol	Characteristic	Min	Typ	Max	Unit	
$f_{MAX}$	Maximum Input Clock Frequency $V_{outpp} \geq 200\text{ mV}$	7	8		GHz	
$f_{DATAMAX}$	Maximum Operating Data Rate (PRBS23)	10.7	12		Gbps	
$f_{SEL}$	Maximum Toggle Frequency, SEL	25	50		MHz	
$V_{OUTPP}$	Output Voltage Amplitude (@ $V_{INPPmin}$ ) (Note 12) (Figures 8 & 10)	$f_{in} \leq 7\text{ GHz}$	200	400		mV
$t_{PLH}$ , $t_{PHL}$	Propagation Delay to Differential Outputs, @ 1 GHz, measured at differential cross-point	$IN_n/\overline{IN}_n$ to Q, $\overline{Q}$ SEL to Q, $\overline{Q}$	120 5	180 13	240 22	ps ns
$t_{PLH\ TC}$	Propagation Delay Temperature Coefficient		50		$\Delta fs/^\circ C$	
$t_{skew}$	Device – Device skew ( $t_{pdmax} - t_{pdmin}$ )			50	ps	
$t_{DC}$	Output Clock Duty Cycle (Reference Duty Cycle = 50%)	$f_{in} \leq 5.0\text{ GHz}$ $f_{in} \leq 7.0\text{ GHz}$	45 40	50 50	55 60	%
$t_{JITTER}$	RJ – Output Random Jitter (Note 13) DJ – Residual Output Deterministic Jitter (Note 14)	$f_{in} \leq 7.0\text{ GHz}$ $f_{in} \leq 10.7\text{ Gbps}$		0.2	0.8 10	ps RMS ps pk-pk
$\Phi_N$	Phase Noise, $f_c = 1\text{ GHz}$	10 kHz 100 kHz 1 MHz 10 MHz 20 MHz 40 MHz		-135 -136 -150 -151 -151 -151		dBc
$t_{\Phi N}$	Integrated Phase Jitter (Figure 4) $f_c = 1\text{ GHz}$ , 12 kHz – 20 MHz Offset (RMS)		35			fs
	Crosstalk Induced Jitter (Adjacent Channel) (Note 15)			0.7		ps RMS
$V_{INPP}$	Input Voltage Swing (Differential Configuration) (Figure 10) (Note 16)		100		1200	mV
$t_r$ , $t_f$	Output Rise/Fall Times @ 1 GHz (20% – 80%)	Q, $\overline{Q}$	15	35	50	ps

NOTE: Device will meet the specifications after thermal equilibrium has been established when mounted in a test socket or printed circuit board with maintained transverse airflow greater than 500 lpm. Electrical parameters are guaranteed only over the declared operating temperature range. Functional operation of the device exceeding these conditions is not implied. Device specification limit values are applied individually under normal operating conditions and not valid simultaneously.

11. Measured using a  $V_{INPPmin}$  source, 50% duty cycle clock source. All output loading with external  $50\ \Omega$  to  $V_{CC}$ . Input edge rates 40 ps (20% – 80%).
12. Output voltage swing is a single-ended measurement operating in differential mode.
13. Additive RMS jitter with 50% duty cycle clock signal.
14. Additive Peak-to-Peak data dependent jitter with input NRZ data at PRBS23 at 3 Gbps.
15. Crosstalk is measured at the output while applying two similar clock frequencies that are asynchronous with respect to each other at the inputs.
16. Input voltage swing is a single-ended measurement operating in differential mode.

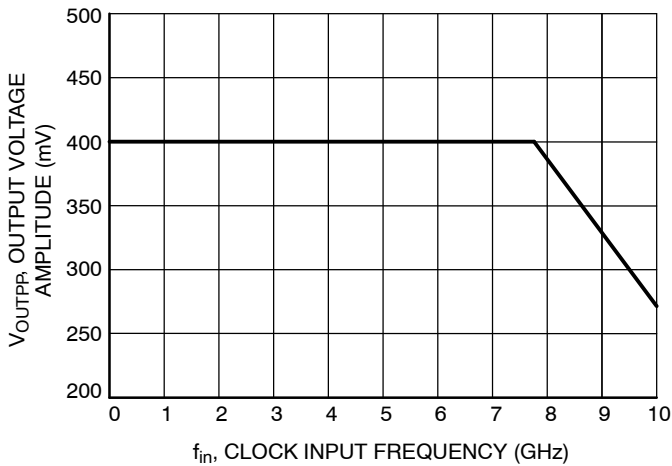

**Figure 3. Output Voltage Amplitude ( $V_{OUTPP}$ ) vs. Input Frequency ( $f_{in}$ ) at Ambient Temperature (Typical)**

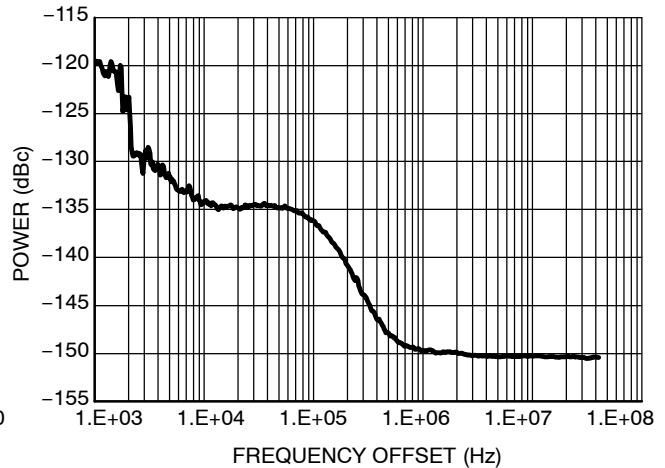

**Figure 4. Typical Phase Noise ( $V_{CC} = 1.8\text{ V}$ ,  $T = 25^\circ\text{C}$ ,  $f_c = 1\text{ GHz}$ )**

# NB7V58M

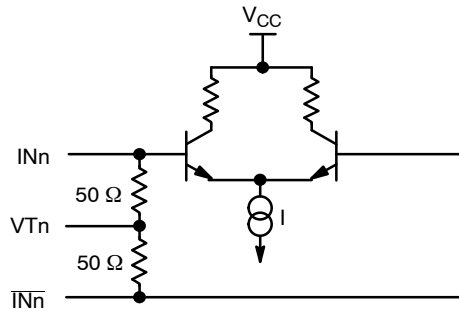

Figure 5. Input Structure

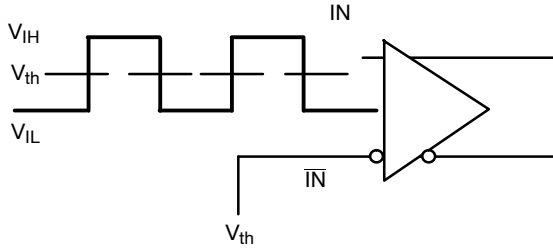

Figure 6. Differential Input Driven Single-Ended

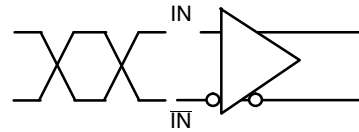

Figure 7. Differential Inputs Driven Differentially

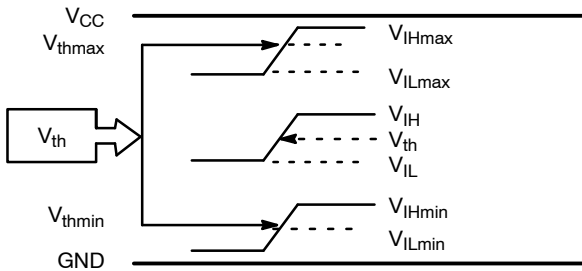

Figure 8.  $V_{th}$  Diagram

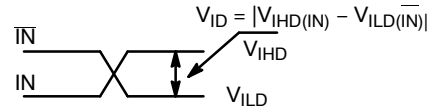

Figure 9.  $V_{ID}$  - Differential Inputs Driven Differentially

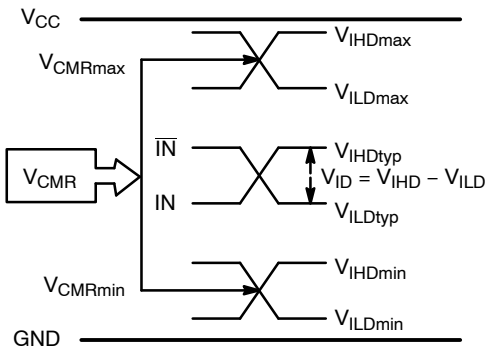

Figure 10.  $V_{CMR}$  Diagram

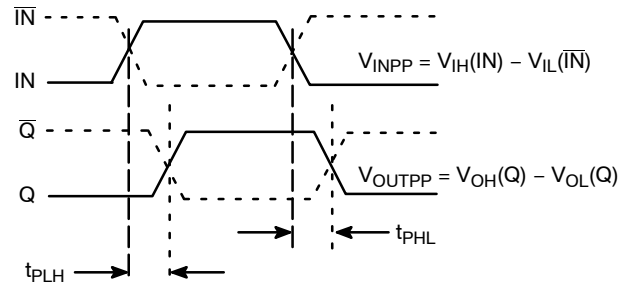

Figure 11. AC Reference Measurement

# NB7V58M

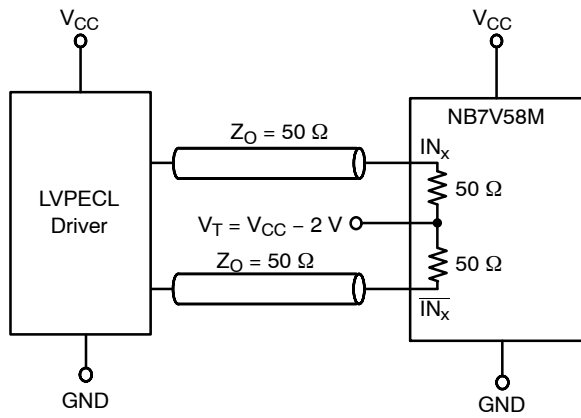

Figure 12. LVPECL Interface

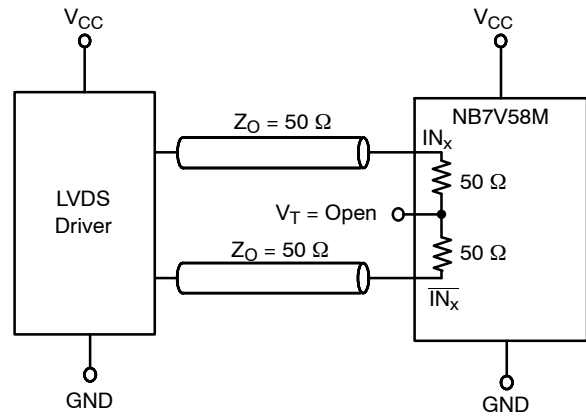

Figure 13. LVDS Interface

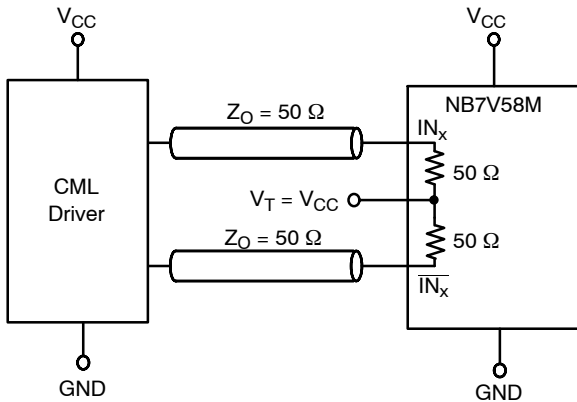

Figure 14. Standard 50  $\Omega$  Load CML Interface

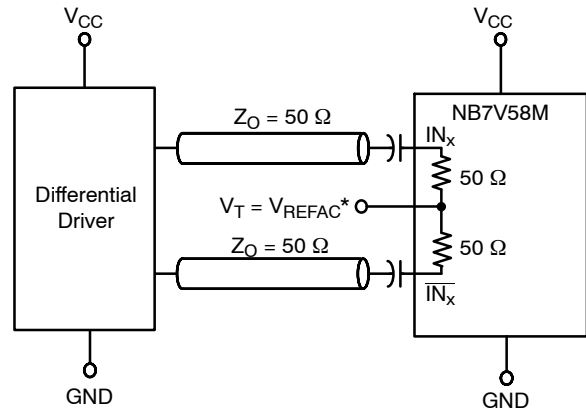

Figure 15. Capacitor-Coupled Differential Interface  
( $V_T$  Connected to External  $V_{REFAC}$ )

\* $V_{REFAC}$  Bypassed to Ground with 0.01  $\mu$ F Capacitor

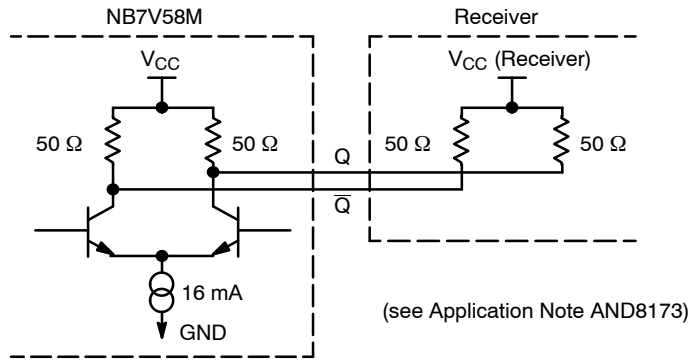

Figure 16. Typical CML Output Structure and Termination

## ORDERING INFORMATION

Device	Package	Shipping <sup>†</sup>
NB7V58MMNG	QFN-16 (Pb-Free)	123 Units / Rail
NB7V58MMNHTBG	QFN-16 (Pb-Free)	100 / Tape & Reel
NB7V58MMNTXG	QFN-16 (Pb-Free)	3000 / Tape & Reel

<sup>†</sup>For information on tape and reel specifications, including part orientation and tape sizes, please refer to our Tape and Reel Packaging Specifications Brochure, BRD8011/D.

# NB7V58M

## PACKAGE DIMENSIONS

16 PIN QFN  
CASE 485G-01  
ISSUE D

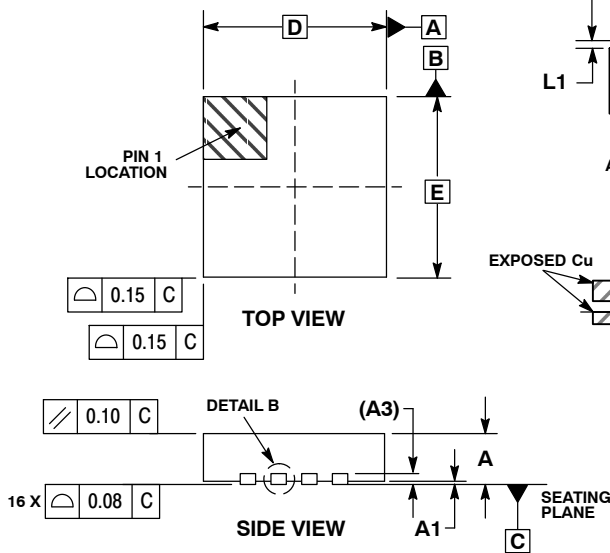

**NOTES:**

1. DIMENSIONING AND TOLERANCING PER ASME Y14.5M, 1994.
2. CONTROLLING DIMENSION: MILLIMETERS.
3. DIMENSION b APPLIES TO PLATED TERMINAL AND IS MEASURED BETWEEN 0.25 AND 0.30 MM FROM TERMINAL.
4. COPLANARITY APPLIES TO THE EXPOSED PAD AS WELL AS THE TERMINALS.
5. L<sub>max</sub> CONDITION CAN NOT VIOLATE 0.2 MM MINIMUM SPACING BETWEEN LEAD TIP AND FLAG

DIM	MILLIMETERS	
	MIN	MAX
A	0.80	1.00
A1	0.00	0.05
A3	0.20 REF	
b	0.18	0.30
D	3.00 BSC	
D2	1.65	1.85
E	3.00 BSC	
E2	1.65	1.85
e	0.50 BSC	
K	0.18 TYP	
L	0.30	0.50
L1	0.00	0.15

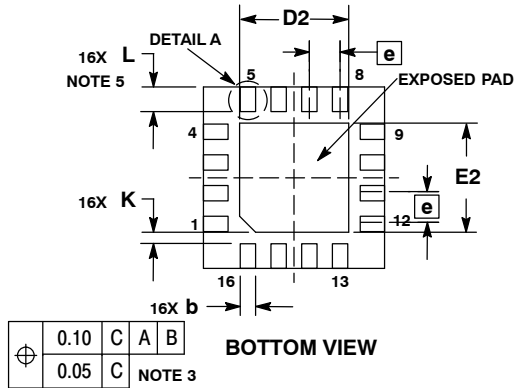

### SOLDERING FOOTPRINT\*

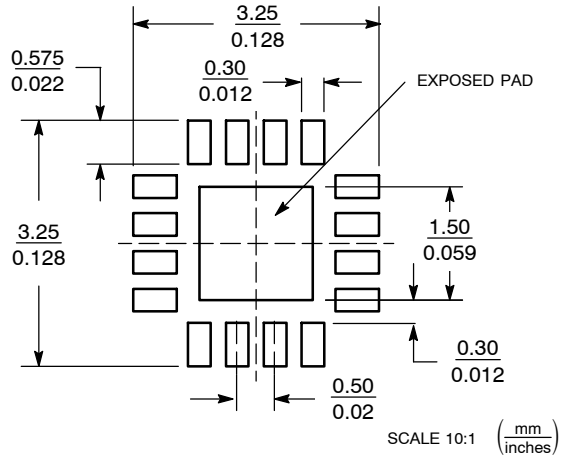

\*For additional information on our Pb-Free strategy and soldering details, please download the ON Semiconductor Soldering and Mounting Techniques Reference Manual, SOLDERRM/D.

GigaComm is a trademark of Semiconductor Component Industries, LLC (SCILLC).

ON Semiconductor and are registered trademarks of Semiconductor Components Industries, LLC (SCILLC). SCILLC reserves the right to make changes without further notice to any products herein. SCILLC makes no warranty, representation or guarantee regarding the suitability of its products for any particular purpose, nor does SCILLC assume any liability arising out of the application or use of any product or circuit, and specifically disclaims any and all liability, including without limitation special, consequential or incidental damages. "Typical" parameters which may be provided in SCILLC data sheets and/or specifications can and do vary in different applications and actual performance may vary over time. All operating parameters, including "Typicals" must be validated for each customer application by customer's technical experts. SCILLC does not convey any license under its patent rights nor the rights of others. SCILLC products are not designed, intended, or authorized for use as components in systems intended for surgical implant into the body, or other applications intended to support or sustain life, or for any other application in which the failure of the SCILLC product could create a situation where personal injury or death may occur. Should Buyer purchase or use SCILLC products for any such unintended or unauthorized application, Buyer shall indemnify and hold SCILLC and its officers, employees, subsidiaries, affiliates, and distributors harmless against all claims, costs, damages, and expenses, and reasonable attorney fees arising out of, directly or indirectly, any claim of personal injury or death associated with such unintended or unauthorized use, even if such claim alleges that SCILLC was negligent regarding the design or manufacture of the part. SCILLC is an Equal Opportunity/Affirmative Action Employer. This literature is subject to all applicable copyright laws and is not for resale in any manner.

### PUBLICATION ORDERING INFORMATION

**LITERATURE FULFILLMENT:**  
Literature Distribution Center for ON Semiconductor  
P.O. Box 5163, Denver, Colorado 80217 USA  
Phone: 303-675-2175 or 800-344-3860 Toll Free USA/Canada  
Fax: 303-675-2176 or 800-344-3867 Toll Free USA/Canada  
Email: orderlit@onsemi.com



**N. American Technical Support:** 800-282-9855 Toll Free USA/Canada  
**Europe, Middle East and Africa Technical Support:**  
Phone: 421 33 790 2910  
**Japan Customer Focus Center**  
Phone: 81-3-5773-3850

**ON Semiconductor Website:** [www.onsemi.com](http://www.onsemi.com)  
**Order Literature:** <http://www.onsemi.com/orderlit>

For additional information, please contact your local Sales Representative

## Looking for pricing, stock, or lifecycle information?

Click below to explore more details on WIN SOURCE:

-  [View NB7V58MMNTXG on WIN SOURCE](#)
-  [ON Semiconductor Information](#)

## Optimize Your Supply Chain with WIN SOURCE Solutions

-  Global Sourcing Solution
-  Obsolete Management
-  Cost Control Management
-  Shortage Management
-  Alternative Solution
-  Excess Inventory Management