



# THE DATASHEET OF NB7L32MMNG



# NB7L32M

## 2.5V/3.3V, 14GHz ÷2 Clock Divider w/CML Output and Internal Termination

### Description

The NB7L32M is an integrated ÷2 divider with differential clock inputs and asynchronous reset.

Differential clock inputs incorporate internal 50 Ω termination resistors and accept LVPECL (Positive ECL), CML, or LVDS. The high frequency reset pin is asserted on the rising edge. Upon power-up, the internal flip-flops will attain a random state; the reset allows for the synchronization of multiple NB7L32M's in a system.

The differential 16 mA CML output provides matching internal 50 Ω termination which guarantees 400 mV output swing when externally receiver terminated 50 Ω to V<sub>CC</sub> (See Figure 15).

The device is housed in a small 3x3 mm 16 pin QFN package.

### Features

- Maximum Input Clock Frequency 14 GHz Typical
- 200 ps Max Propagation Delay
- 30 ps Typical Rise and Fall Times
- < 0.5 ps Maximum (RMS) Random Clock Jitter
- Operating Range: V<sub>CC</sub> = 2.375 V to 3.465 V with V<sub>EE</sub> = 0 V
- CML Output Level (400 mV Peak-to-Peak Output), Differential Output Only
- 50 Ω Internal Input and Output Termination Resistors
- Functionally Compatible with Existing 2.5 V / 3.3 V LVEL, LVEP, EP, and SG Devices
- These are Pb-Free Devices



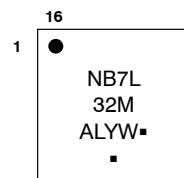
ON Semiconductor®

<http://onsemi.com>



QFN-16  
MN SUFFIX  
CASE 485G

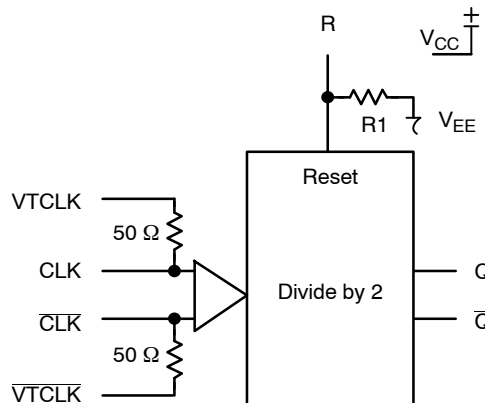
### MARKING DIAGRAM\*



- A = Assembly Location
- L = Wafer Lot
- Y = Year
- W = Work Week
- = Pb-Free Package

\*For additional marking information, refer to Application Note AND8002/D.

### FUNCTIONAL BLOCK DIAGRAM



### TRUTH TABLE

CLK	CLK	R	Q	Q̄
x	x	H	L	H
Z	W	L	÷2	÷2

Z = LOW to HIGH Transition  
W = HIGH to LOW Transition  
x = Don't Care

### ORDERING INFORMATION

See detailed ordering and shipping information in the package dimensions section on page 9 of this data sheet.

## NB7L32M

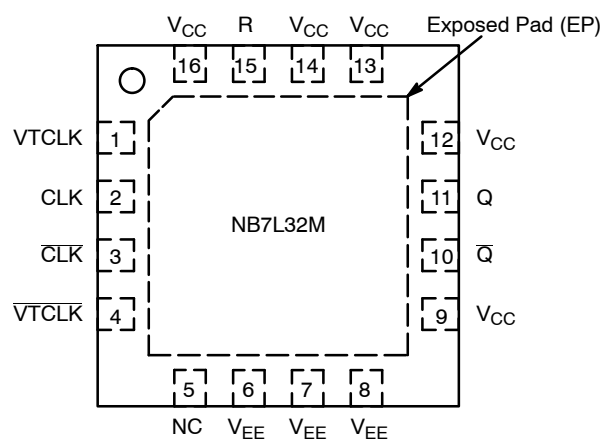


Figure 1. Pin Configuration (Top View)

Table 1. PIN DESCRIPTION

Pin	Name	I/O	Description
1	VTCLK	-	Internal 50 $\Omega$ termination pin. In the differential configuration when the input termination pin (VTCLK, VTCLK) are connected to a common termination voltage or left open, and if no signal is applied on CLK/CLK input then the device will be susceptible to self-oscillation.
2	CLK	ECL, CML, LVDS Input	Noninverted differential input. In the differential configuration when the input termination pin (VTCLK, VTCLK) are connected to a common termination voltage or left open and if no signal is applied on CLK/CLK input, then the device will be susceptible to self-oscillation.
3	CLK	ECL, CML, LVDS Input	Inverted differential input. In the differential configuration when the input termination pin (VTCLK, VTCLK) are connected to a common termination voltage or left open and if no signal is applied on CLK/CLK input, then the device will be susceptible to self-oscillation.
4	VTCLK	-	Internal 50 $\Omega$ termination pin. In the differential configuration when the input termination pin (VTCLK, VTCLK) are connected to a common termination voltage or left open and if no signal is applied on CLK/CLK input, then the device will be susceptible to self-oscillation.
5	NC	-	No connect. NC pin must be left open.
6, 7, 8	VEE	-	Negative supply voltage.
9, 12, 13, 14, 16	VCC	-	Positive supply voltage.
10	Q	CML Output	Inverted differential output. Typically terminated with 50 $\Omega$ resistor to VCC.
11	Q	CML Output	Noninverted differential output. Typically terminated with 50 $\Omega$ resistor to VCC.
15	R	LVTTL/LVCMOS	Reset Input. Internal pulldown to 75 k $\Omega$ to VEE.
-	EP	-	Exposed Pad. The thermally exposed pad (EP) on package bottom (see case drawing) must be attached to a heat-sinking conduit. EP is electrically isolated from VCC and VEE.

# NB7L32M

**Table 2. ATTRIBUTES**

Characteristics		Value
Internal Input Pulldown Resistor	R1	75 k $\Omega$
ESD Protection	Human Body Model Machine Model	> 500 V > 30 V
Moisture Sensitivity (Note 1)	QFN-16	Level 1
Flammability Rating	Oxygen Index: 28 to 34	UL 94 V-0 @ 0.125 in
Transistor Count		349
Meets or exceeds JEDEC Spec EIA/JESD78 IC Latchup Test		

1. For additional information, see Application Note AND8003/D.

**Table 3. MAXIMUM RATINGS**

Symbol	Parameter	Condition 1	Condition 2	Rating	Unit
V <sub>CC</sub>	Positive Power Supply	V <sub>EE</sub> = 0 V		3.6	V
V <sub>EE</sub>	Negative Power Supply	V <sub>CC</sub> = 0 V		-3.6	V
V <sub>I</sub>	Positive Input Negative Input	V <sub>EE</sub> = 0 V V <sub>CC</sub> = 0 V	V <sub>I</sub> ≤ V <sub>CC</sub> V <sub>I</sub> ≥ V <sub>EE</sub>	3.6 -3.6	V V
V <sub>INPP</sub>	Differential Input Voltage			2.8	V
I <sub>IN</sub>	Input Current Through R <sub>T</sub> (50 $\Omega$ Resistor)	Static Surge		45 80	mA mA
I <sub>out</sub>	Output Current	Continuous Surge		25 50	mA mA
T <sub>A</sub>	Operating Temperature Range	QFN-16		-40 to +85	°C
T <sub>stg</sub>	Storage Temperature Range			-65 to +150	°C
$\theta_{JA}$	Thermal Resistance (Junction-to-Ambient) (Note 2)	0 lfpm 500 lfpm	QFN-16 QFN-16	41.6 35.2	°C/W °C/W
$\theta_{JC}$	Thermal Resistance (Junction-to-Case)	1S2P	QFN-16	4.0	°C/W
T <sub>sol</sub>	Wave Solder	Pb-Free	<3 sec @ 260°C	265	°C

Stresses exceeding Maximum Ratings may damage the device. Maximum Ratings are stress ratings only. Functional operation above the Recommended Operating Conditions is not implied. Extended exposure to stresses above the Recommended Operating Conditions may affect device reliability.

2. JEDEC standard multilayer board – 1S2P (1 signal, 2 power) with 8 filled thermal vias under exposed pad.

# NB7L32M

**Table 4. DC CHARACTERISTICS, CLOCK INPUTS, CML OUTPUTS**  $V_{CC} = 2.375\text{ V to }3.465\text{ V}$ ,  $V_{EE} = 0\text{ V}$ ,  
 $T_A = -40^\circ\text{C to }+85^\circ\text{C}$

Symbol	Characteristic	Min	Typ	Max	Unit
$I_{CC}$	Power Supply Current (Note 3)	50	65	80	mA
$V_{OH}$	Output HIGH Voltage (Note 4)	$V_{CC} - 40$	$V_{CC} - 10$	$V_{CC}$	mV
$V_{OL}$	Output LOW Voltage (Note 4)	$V_{CC} - 500$	$V_{CC} - 400$	$V_{CC} - 300$	mV
$R_{TOUT}$	Internal Output Termination Resistor	45	50	55	$\Omega$
$R_{Temp}$ Coef	Internal I/O Termination Resistor Temperature Coefficient		6.38		$\text{m}\Omega/^\circ\text{C}$

**DIFFERENTIAL CLK/CLK INPUT DRIVEN SINGLE-ENDED** (see Figure 9 and 11)

$V_{th}$	Input Threshold Reference Voltage Range (Note 6)	1050		$V_{CC}$	mV
$V_{IH}$	Single-ended Input HIGH Voltage	$V_{th} + 150$		$V_{CC} + 300$	mV
$V_{IL}$	Single-ended Input LOW Voltage	$V_{EE}$		$V_{th} - 150$	mV

**DIFFERENTIAL CLK/CLK INPUTS DRIVEN DIFFERENTIALLY** (see Figure 10 and 12)

$V_{IHD}$	Differential Input HIGH Voltage	1200		$V_{CC} + 300$	mV
$V_{ILD}$	Differential Input LOW Voltage	$V_{EE}$		$V_{CC} - 75$	mV
$V_{CMR}$	Input Common Mode Range (Differential Configuration, Note 7)	1125		$V_{CC}$	mV
$V_{ID}$	Differential Input Voltage ( $V_{IHD} - V_{ILD}$ )	150		2500	mV

$I_{IH}$	Input HIGH Current	CLK/CLK ( $\sqrt{VTCLK/R}/\sqrt{VTCLK/R}$ Open)	0	30	100	$\mu\text{A}$
$I_{IL}$	Input LOW Current	CLK/CLK ( $\sqrt{VTCLK/R}/\sqrt{VTCLK/R}$ Open)	-50	0	50	$\mu\text{A}$
$R_{TIN}$	Internal Input Termination Resistor		45	50	55	$\Omega$

**LVTTL/LVCMOS RESET INPUT**

$V_{IH}$	Single-ended Input HIGH Voltage		2000		$V_{CC}$	mV
$V_{IL}$	Single-ended Input LOW Voltage		$V_{EE}$		800	mV
$I_{IH}$	Input HIGH Current	R	0	30	100	$\mu\text{A}$
$I_{IL}$	Input LOW Current	R	0	10	100	$\mu\text{A}$

NOTE: Device will meet the specifications after thermal equilibrium has been established when mounted in a test socket or printed circuit board with maintained transverse airflow greater than 500 lpm. Electrical parameters are guaranteed only over the declared operating temperature range. Functional operation of the device exceeding these conditions is not implied. Device specification limit values are applied individually under normal operating conditions and not valid simultaneously.

- Input termination pins open and all outputs loaded with external  $R_L = 50\ \Omega$  receiver termination resistor.
- CML outputs require  $R_L = 50\ \Omega$  receiver termination resistors to  $V_{CC}$  for proper operation. (See Figure 8)
- Input and output parameters vary 1:1 with  $V_{CC}$ .
- $V_{th}$  is applied to the complementary input when operating in single-ended mode.
- $V_{CMR(MIN)}$  varies 1:1 with  $V_{EE}$ ,  $V_{CMR}$  max varies 1:1 with  $V_{CC}$ . The  $V_{CMR}$  range is referenced to the most positive side of the differential input signal.

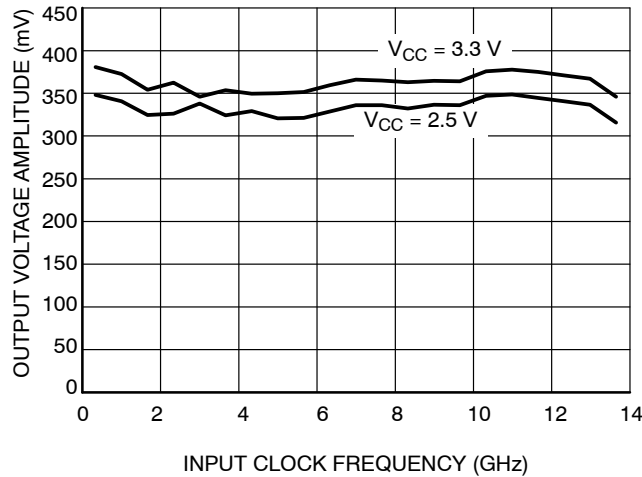
# NB7L32M

**Table 6. AC CHARACTERISTICS**  $V_{CC} = 2.375\text{ V to }3.465\text{ V}$ ,  $V_{EE} = 0\text{ V}$  (Note 8)

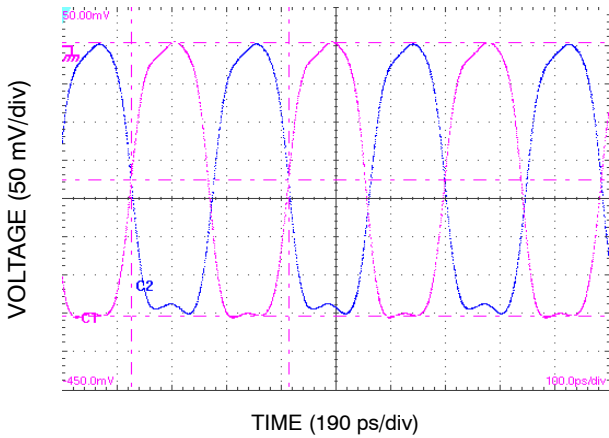
Symbol	Characteristic	-40°C			25°C			85°C			Unit
		Min	Typ	Max	Min	Typ	Max	Min	Typ	Max	
$V_{OUTPP}$	Output Voltage Amplitude (@ $V_{INPP(MIN)}$ ) $f_{in} \leq 7\text{ GHz}$ (See Figures 2, 3, 4, 5, and 6) $f_{in} \leq 12\text{ GHz}$	190 160	330 320		190 160	330 320		190 160	330 320		mV
$f_{IN}$	Maximum Input Clock Frequency (See Figure 2)	12	14		12	14		12	14		GHz
$t_{PLH}$ , $t_{PHL}$	Propagation Delay to Output Differential (See Figure 7) CLK to Q R to Q	130 200	155 240	200 300	130 200	155 240	200 300	130 200	155 260	200 300	ps
$t_{skew}$	Duty Cycle Skew (Note 9) Device-to-Device Skew (Note 12)		2 6	20 50		2 6	20 50		2 6	20 50	
$t_{RR}$	Reset Recovery (See Figure 7)	300	135		300	135		300	135		ps
$t_{PW}$	Minimum Pulse Width R	500	210		500	210		500	210		ps
$t_{JITTER}$	Random Clock Jitter (RMS) (Note 11) $f_{in} \leq 7\text{ GHz}$ $f_{in} = 12\text{ GHz}$		0.13 0.14	0.5 0.5		0.13 0.14	0.5 0.5		0.13 0.14	0.5 0.5	ps
$V_{INPP}$	Input Voltage Swing/Sensitivity (Differential Configuration) (Note 10)	150		2500	150		2500	150		2500	mV
$t_r$ , $t_f$	Output Rise/Fall Times @ 1 GHz (20% – 80%)		30	45		30	45		30	45	ps

NOTE: Device will meet the specifications after thermal equilibrium has been established when mounted in a test socket or printed circuit board with maintained transverse airflow greater than 500 lfm. Electrical parameters are guaranteed only over the declared operating temperature range. Functional operation of the device exceeding these conditions is not implied. Device specification limit values are applied individually under normal operating conditions and not valid simultaneously.

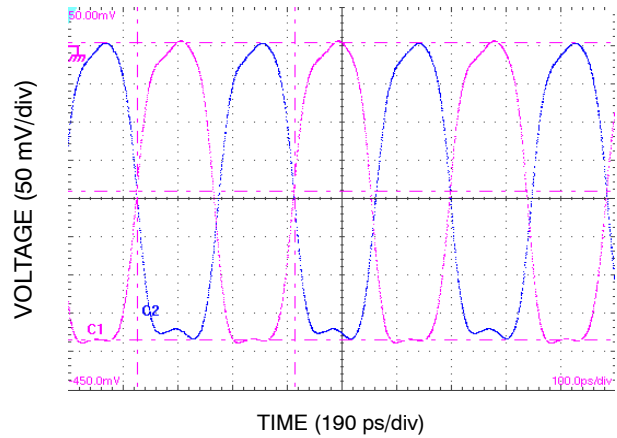
8. Measured by forcing  $V_{INPP(MIN)}$  from a 50% duty cycle clock source. All loading with an external  $R_L = 50\ \Omega$  to  $V_{CC}$ . Input edge rates 40 ps (20% – 80%).
9. Duty cycle skew is measured between differential outputs using the deviations of the sum of  $T_{pw-}$  and  $T_{pw+}$  1 GHz.
10.  $V_{INPP(MAX)}$  cannot exceed  $V_{CC} - V_{EE}$ . Input voltage swing is a single-ended measurement operating in differential mode.
11. Additive RMS jitter with 50% duty cycle input clock signal.
12. Device-to-device skew is measured between outputs under identical transition @ 1 GHz.



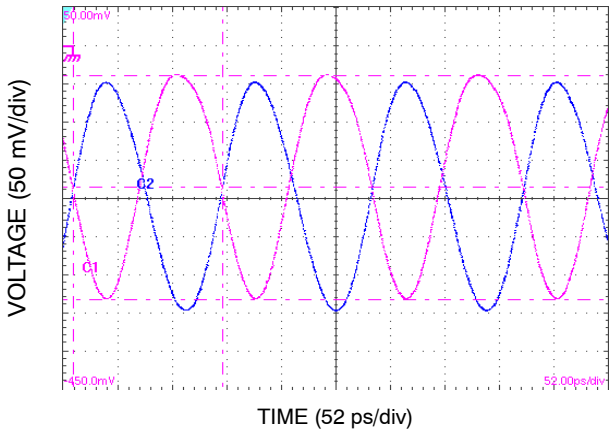
**Figure 2. Output Voltage Amplitude ( $V_{OUTPP}$ ) versus Input Clock Frequency ( $f_{OUT}$ ) at Ambient Temperature ( $V_{INPP} = 150\text{ mV}$ )**



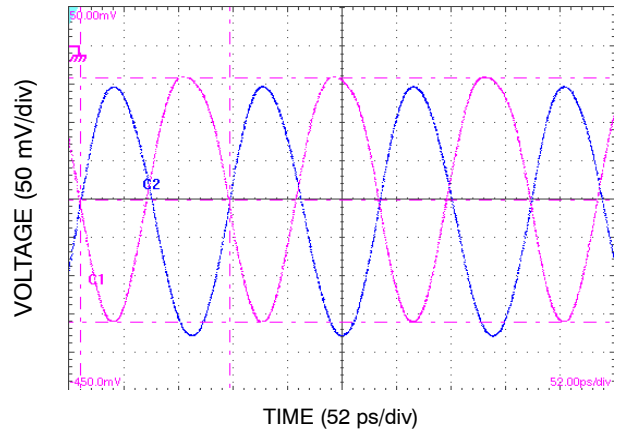
**Figure 3. Typical Output Waveform with  $f_{IN} = 7$  GHz ( $V_{CC} = 2.5$  V,  $V_{INPP} = 400$  mV, Room Temperature,  $V_{OUTPP} = 357$  mV,  $t_r = 33$  ps,  $t_f = 30$  ps,  $f_{OUT} = 3.499$  GHz)**



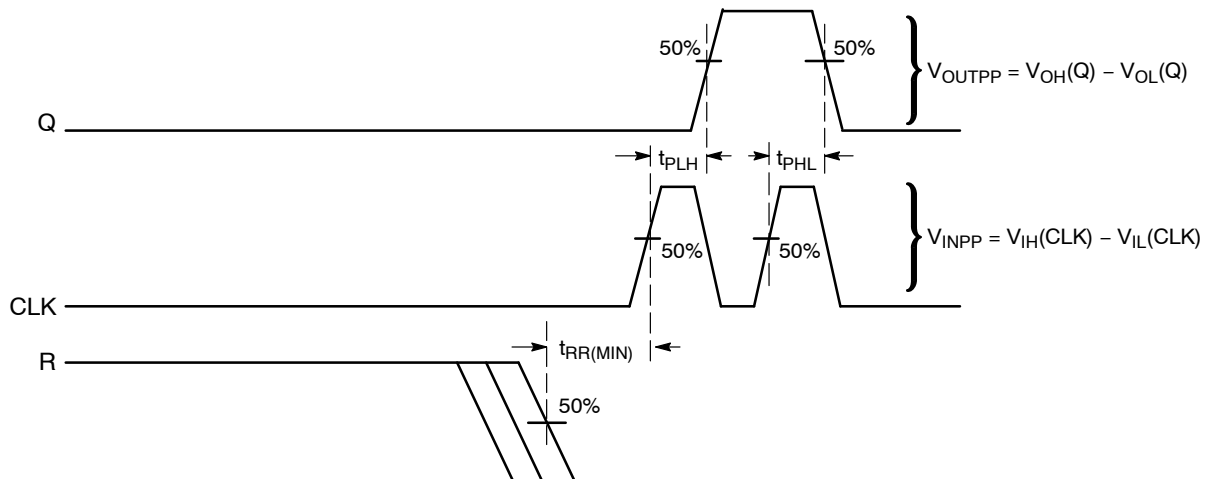
**Figure 4. Typical Output Waveform with  $f_{IN} = 7$  GHz ( $V_{CC} = 3.3$  V,  $V_{INPP} = 400$  mV, Room Temperature,  $V_{OUTPP} = 387$  mV,  $t_r = 32$  ps,  $t_f = 29.8$  ps,  $f_{OUT} = 3.499$  GHz)**



**Figure 5. Typical Output Waveform with  $f_{IN} = 14$  GHz ( $V_{CC} = 2.5$  V,  $V_{INPP} = 400$  mV, Room Temperature,  $V_{OUTPP} = 292$  mV,  $t_r = 25$  ps,  $t_f = 27$  ps,  $f_{OUT} = 7.01$  GHz)**

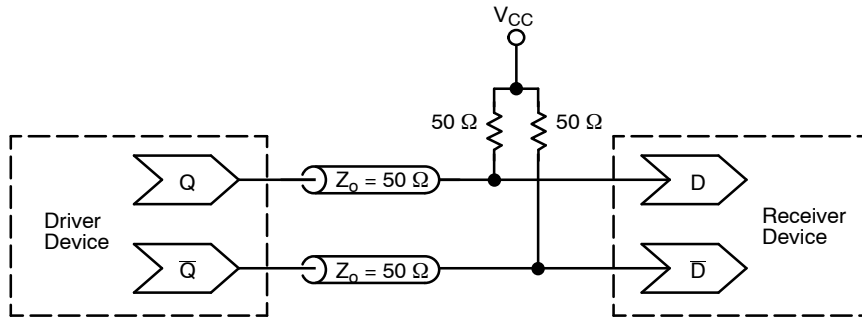


**Figure 6. Typical Output Waveform with  $f_{IN} = 14$  GHz ( $V_{CC} = 3.3$  V,  $V_{INPP} = 400$  mV, Room Temperature,  $V_{OUTPP} = 319$  mV,  $t_r = 25$  ps,  $t_f = 26$  ps,  $f_{OUT} = 7.01$  GHz)**

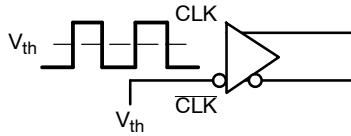


**Figure 7. AC Reference Measurement (Timing Diagram)**

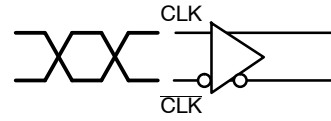
# NB7L32M



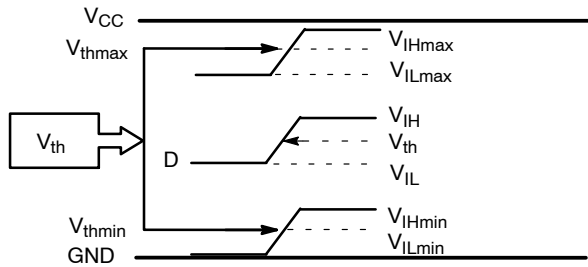
**Figure 8. Typical Termination for Output Driver and Device Evaluation**  
(See Application Note AND8073/D – Termination of CML Logic Devices.)



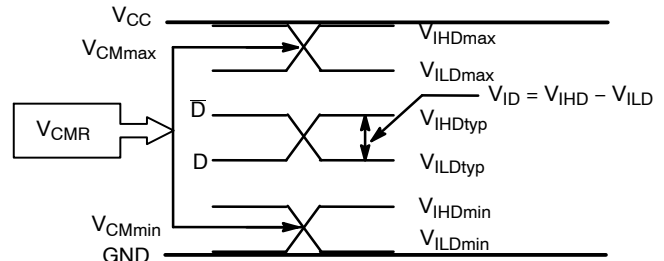
**Figure 9. Differential Input Driven Single-Ended**



**Figure 10. Differential Inputs Driven Differentially**

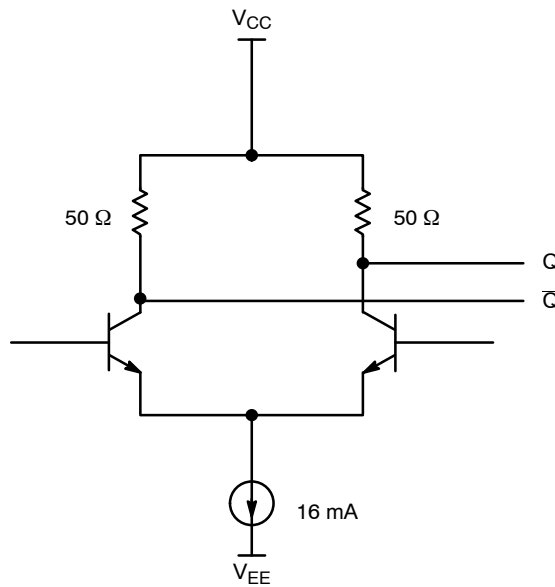


**Figure 11.  $V_{th}$  Diagram**



**Figure 12.  $V_{CMR}$  Diagram**

NOTE:  $V_{EE} \leq V_{IN} \leq V_{CC} + 300 \text{ mV}$ ;  $V_{IH} > V_{IL}$



**Figure 13. CML Output Structure**

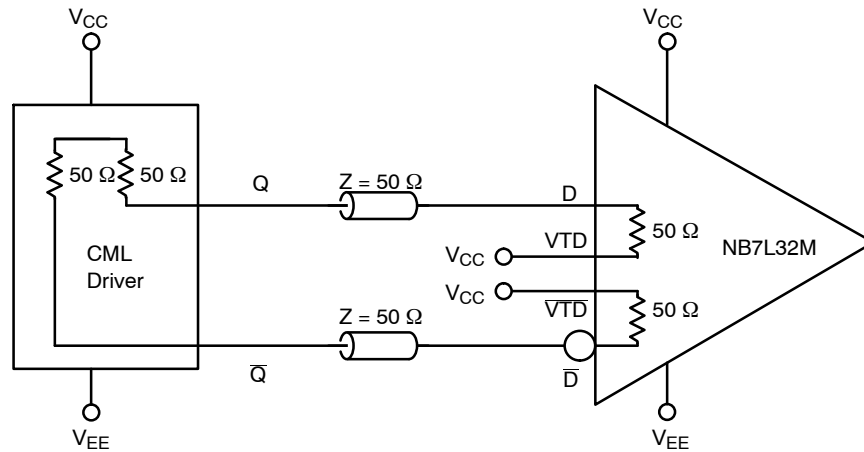
# NB7L32M

## APPLICATION INFORMATION

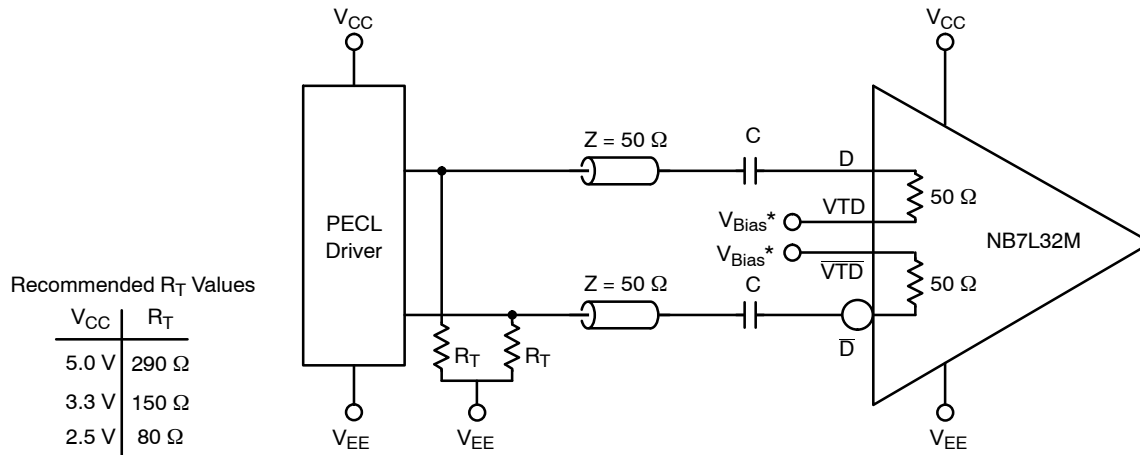
All NB7L32M inputs can accept PECL, CML, and LVDS signal levels. The limitations for differential input signal (LVDS, PECL, or CML) are minimum input swing of 150 mV and the maximum input swing of 2500 mV. Within these conditions, the input voltage can range from  $V_{CC}$  to 1.2 V. Examples interfaces are illustrated below in a 50  $\Omega$  environment ( $Z = 50 \Omega$ ). For output termination and interface, refer to application note AND8020/D.

**Table 5. INTERFACING OPTIONS**

Interfacing Options	Connections
CML	Connect VTD and $\overline{VTD}$ to $V_{CC}$ (See Figure 14)
LVDS	Connect VTD and $\overline{VTD}$ Together (See Figure 16)
AC-COUPLED	Bias VTD and $\overline{VTD}$ Inputs within Common Mode Range ( $V_{CMR}$ ) (See Figure 15)
RSECL, PECL, NECL	Standard ECL Termination Techniques (See Figure 8)



**Figure 14. CML to NB7L32M Interface**



Recommended  $R_T$  Values

$V_{CC}$	$R_T$
5.0 V	290 $\Omega$
3.3 V	150 $\Omega$
2.5 V	80 $\Omega$

\* $V_{Bias}$  must be within common mode range limits ( $V_{CMR}$ )

**Figure 15. PECL to NB7L32M Interface**

# NB7L32M

## APPLICATION INFORMATION

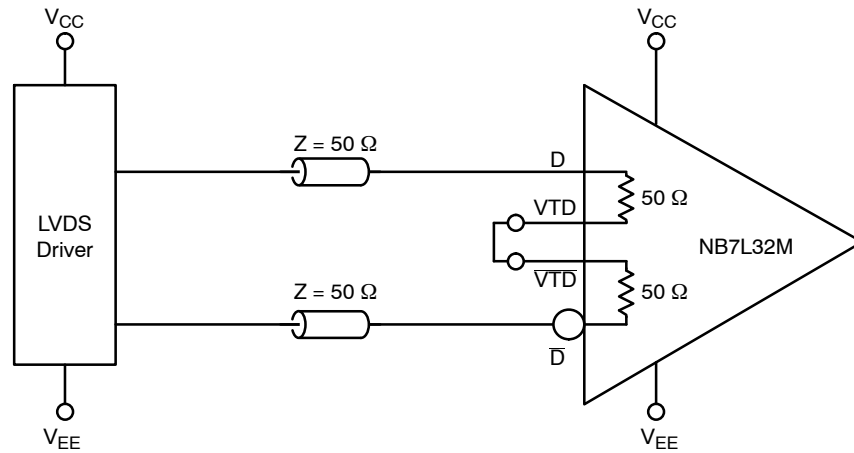


Figure 16. LVDS to NB7L32M Interface

## ORDERING INFORMATION

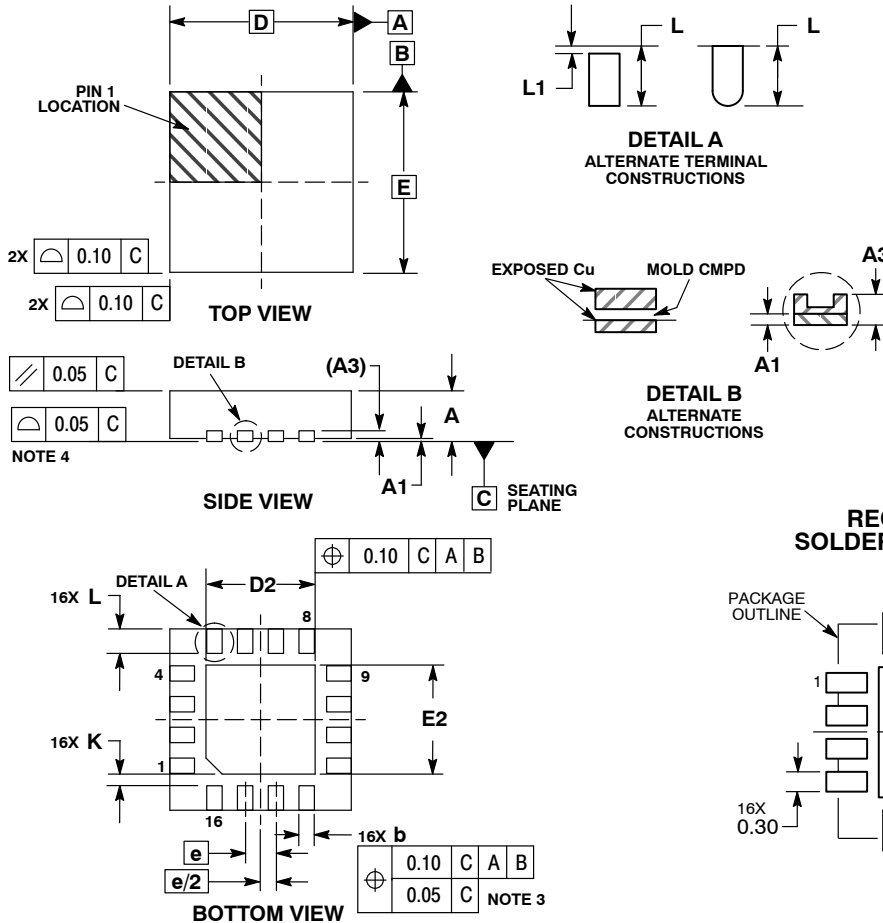
Device	Package	Shipping†
NB7L32MMNG	QFN-16 (Pb-Free)	123 Units / Rail
NB7L32MMNR2G	QFN-16 (Pb-Free)	3000 / Tape & Reel

†For information on tape and reel specifications, including part orientation and tape sizes, please refer to our Tape and Reel Packaging Specifications Brochure, BRD8011/D.

# NB7L32M

## PACKAGE DIMENSIONS

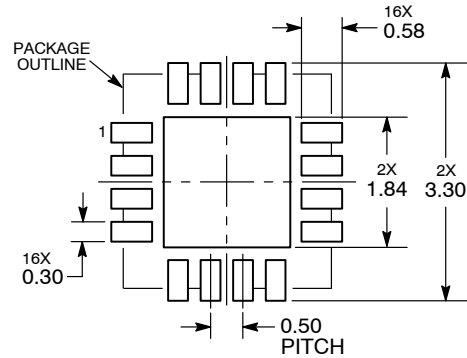
QFN16 3x3, 0.5P  
CASE 485G-01  
ISSUE F



- NOTES:
1. DIMENSIONING AND TOLERANCING PER ASME Y14.5M, 1994.
  2. CONTROLLING DIMENSION: MILLIMETERS.
  3. DIMENSION b APPLIES TO PLATED TERMINAL AND IS MEASURED BETWEEN 0.25 AND 0.30 MM FROM TERMINAL.
  4. COPLANARITY APPLIES TO THE EXPOSED PAD AS WELL AS THE TERMINALS.

MILLIMETERS			
DIM	MIN	NOM	MAX
A	0.80	0.90	1.00
A1	0.00	0.03	0.05
A3	0.20 REF		
b	0.18	0.24	0.30
D	3.00 BSC		
D2	1.65	1.75	1.85
E	3.00 BSC		
E2	1.65	1.75	1.85
e	0.50 BSC		
K	0.18 TYP		
L	0.30	0.40	0.50
L1	0.00	0.08	0.15

### RECOMMENDED SOLDERING FOOTPRINT\*



DIMENSIONS: MILLIMETERS

\*For additional information on our Pb-Free strategy and soldering details, please download the ON Semiconductor Soldering and Mounting Techniques Reference Manual, SOLDERRM/D.

ON Semiconductor and are registered trademarks of Semiconductor Components Industries, LLC (SCILLC). SCILLC reserves the right to make changes without further notice to any products herein. SCILLC makes no warranty, representation or guarantee regarding the suitability of its products for any particular purpose, nor does SCILLC assume any liability arising out of the application or use of any product or circuit, and specifically disclaims any and all liability, including without limitation special, consequential or incidental damages. "Typical" parameters which may be provided in SCILLC data sheets and/or specifications can and do vary in different applications and actual performance may vary over time. All operating parameters, including "Typicals" must be validated for each customer application by customer's technical experts. SCILLC does not convey any license under its patent rights nor the rights of others. SCILLC products are not designed, intended, or authorized for use as components in systems intended for surgical implant into the body, or other applications intended to support or sustain life, or for any other application in which the failure of the SCILLC product could create a situation where personal injury or death may occur. Should Buyer purchase or use SCILLC products for any such unintended or unauthorized application, Buyer shall indemnify and hold SCILLC and its officers, employees, subsidiaries, affiliates, and distributors harmless against all claims, costs, damages, and expenses, and reasonable attorney fees arising out of, directly or indirectly, any claim of personal injury or death associated with such unintended or unauthorized use, even if such claim alleges that SCILLC was negligent regarding the design or manufacture of the part. SCILLC is an Equal Opportunity/Affirmative Action Employer. This literature is subject to all applicable copyright laws and is not for resale in any manner.

### PUBLICATION ORDERING INFORMATION

**LITERATURE FULFILLMENT:**  
Literature Distribution Center for ON Semiconductor  
P.O. Box 5163, Denver, Colorado 80217 USA  
**Phone:** 303-675-2175 or 800-344-3860 Toll Free USA/Canada  
**Fax:** 303-675-2176 or 800-344-3867 Toll Free USA/Canada  
**Email:** orderlit@onsemi.com

**N. American Technical Support:** 800-282-9855 Toll Free USA/Canada  
**Europe, Middle East and Africa Technical Support:**  
Phone: 421 33 790 2910  
**Japan Customer Focus Center**  
Phone: 81-3-5817-1050

**ON Semiconductor Website:** [www.onsemi.com](http://www.onsemi.com)  
**Order Literature:** <http://www.onsemi.com/orderlit>  
For additional information, please contact your local Sales Representative

## Looking for pricing, stock, or lifecycle information?

Click below to explore more details on WIN SOURCE:

- ⊖ [View NB7L32MMNG on WIN SOURCE](#)
- ⊖ [ON Semiconductor Information](#)

## Optimize Your Supply Chain with WIN SOURCE Solutions

- ✓ Global Sourcing Solution
- ✓ Obsolete Management
- ✓ Cost Control Management
- ✓ Shortage Management
- ✓ Alternative Solution
- ✓ Excess Inventory Management