



**THE DATASHEET OF  
NB6N239SMNR2G**



# NB6N239S

## 3.3 V, 3.0 GHz Any Differential Clock IN to LVDS OUT $\div 1/2/4/8$ , $\div 2/4/8/16$ Clock Divider



ON Semiconductor®

<http://onsemi.com>

### Description

The NB6N239S is a high-speed, low skew clock divider with two divider circuits, each having selectable clock divide ratios;  $\div 1/2/4/8$  and  $\div 2/4/8/16$ . Both divider circuits drive LVDS compatible outputs. (More device information on page 7). The NB6N239S is a member of the ECLinPS MAX™ family of high performance clock products.

### Features

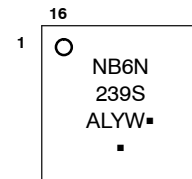
- Maximum Clock Input Frequency, 3.0 GHz (1.5 GHz with  $\div 1$ )
- Input Compatibility with LVDS/LVPECL/CML/HSTL/HCSL
- Rise/Fall Time 120 ps Typical
- $< 5$  ps Typical Within Device Output Skew
- Example; 622.08 MHz Input Generates 38.88 MHz to 622.08 MHz Outputs
- Internal 50  $\Omega$  Termination Provided
- Random Clock Jitter  $< 2$  ps RMS
- QA  $\div 1$  Edge Aligned to QB  $\div n$  Edge
- Operating Range:  $V_{CC} = 3.0$  V to 3.465 V with GND = 0 V
- Master Reset for Synchronization of Multiple Chips
- $V_{BBAC}$  Reference Output
- Synchronous Output Enable/Disable
- TIA/EIA – 644 Compliant
- These Devices are Pb-Free and are RoHS Compliant

### MARKING DIAGRAM\*



Bottom View

QFN-16  
MN SUFFIX  
CASE 485G



- A = Assembly Location
- L = Wafer Lot
- Y = Year
- W = Work Week
- = Pb-Free Package

(Note: Microdot may be in either location)

\*For additional marking information, refer to Application Note AND8002/D.

### ORDERING INFORMATION

See detailed ordering and shipping information in the package dimensions section on page 11 of this data sheet.

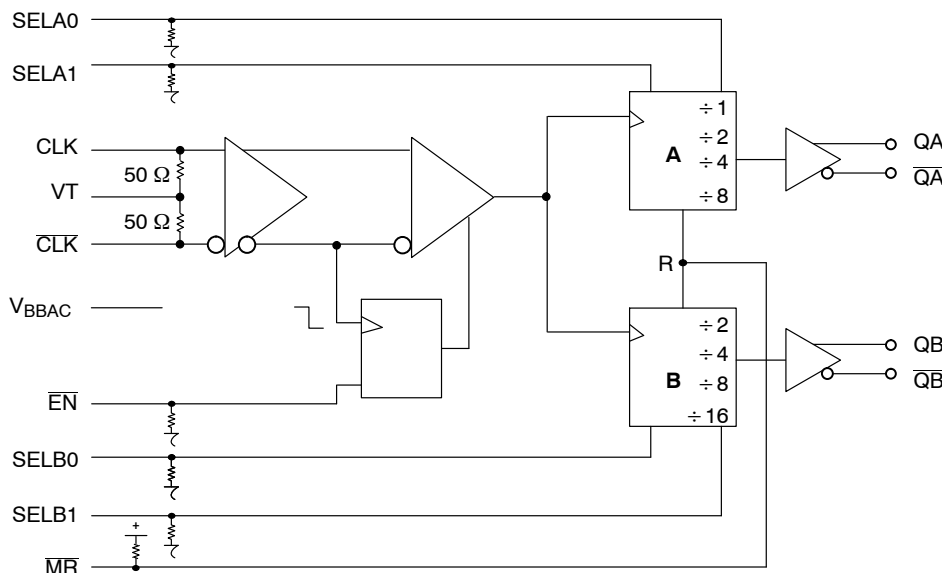
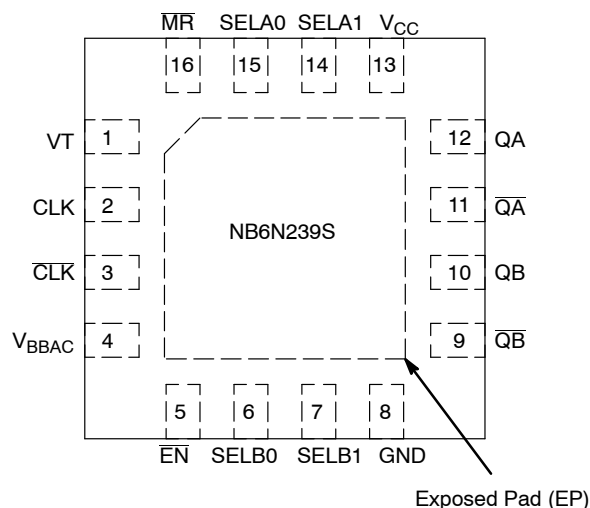


Figure 1. Simplified Logic Diagram

# NB6N239S



**Figure 2. Pinout: QFN-16 (Top View)**

**Table 1. PIN DESCRIPTION**

Pin	Name	I/O	Description
1	VT		Internal 100 $\Omega$ Center-Tapped Termination Pin for CLK and $\overline{\text{CLK}}$ .
2	CLK	LVDS, LVPECL, CML, HCSL, HSTL Input	Noninverted Differential CLOCK Input.
3	$\overline{\text{CLK}}$	LVDS, LVPECL, CML, HCSL, HSTL Input	Inverted Differential CLOCK Input.
4	$V_{\text{BBAC}}$		Output Voltage Reference for Capacitor Coupled Inputs, only.
5	EN*	LVC MOS/LVTTL Input	Synchronous Output Enable
6	SELB0*	LVC MOS/LVTTL Input	Clock Divide Select Pin
7	SELB1*	LVC MOS/LVTTL Input	Clock Divide Select Pin
8	GND	Power Supply	Negative Supply Voltage
9	$\overline{\text{QB}}$	LVDS Output	Inverted Differential Output. Typically terminated with 100 $\Omega$ across differential outputs.
10	QB	LVDS Output	Noninverted Differential Output. Typically terminated with 100 $\Omega$ across differential outputs.
11	$\overline{\text{QA}}$	LVDS Output	Inverted Differential Output. Typically terminated with 100 $\Omega$ across differential outputs.
12	QA	LVDS Output	Noninverted Differential Output. Typically terminated with 100 $\Omega$ across differential outputs.
13	$V_{\text{CC}}$	Power Supply	Positive Supply Voltage.
14	SELA1*	LVC MOS/LVTTL Input	Clock Divide Select Pin
15	SELA0*	LVC MOS/LVTTL Input	Clock Divide Select Pin
16	$\overline{\text{MR}}$ **	LVC MOS/LVTTL Input	Master Reset Asynchronous, Default Open High, Asserted LOW
	EP	Power Supply (OPT)	The Exposed Pad on the QFN-16 package bottom is thermally connected to the die for improved heat transfer out of package. The pad is electrically connected to the die, and is recommended to be electrically and thermally connected to GND on the PC board.

\*Pins will default LOW when left OPEN.

\*\*Pins will default HIGH when left OPEN.

# NB6N239S

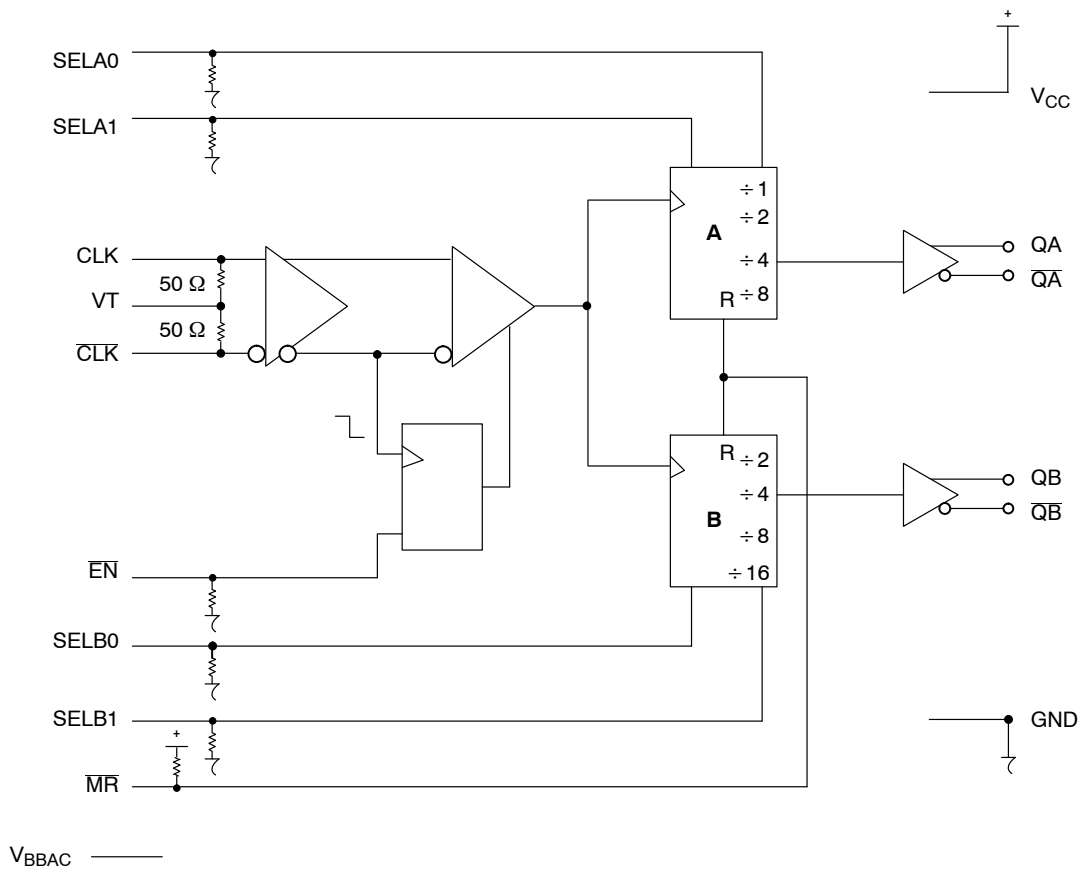


Figure 3. Logic Diagram

Table 2. FUNCTION TABLE

CLK	EN*	MR**	FUNCTION
⌋	L	H	Divide
⌋	H	H	Hold Q
X	X	L	Reset Q

Table 3. CLOCK DIVIDE SELECT, QA OUTPUTS

SELA1*	SELA0*	QA Outputs
L	L	Divide by 1
L	H	Divide by 2
H	L	Divide by 4
H	H	Divide by 8

Table 4. CLOCK DIVIDE SELECT, QB OUTPUTS

SELB1*	SELB0*	QB Outputs
L	L	Divide by 2
L	H	Divide by 4
H	L	Divide by 8
H	H	Divide by 16

⌋ = Low-to-High Transition

⌋ = High-to-Low Transition

X = Don't Care

\*Pins will default LOW when left OPEN.

\*\*Pins will default HIGH when left OPEN.

# NB6N239S

**Table 5. ATTRIBUTES**

Characteristics	Value
Internal Input Pulldown Resistor Internal Input Pullup Resistor	75 k $\Omega$ 75 k $\Omega$
ESD Protection	Human Body Model Machine Model Charged Device Model
	> 1500 V > 100 V > 1000 V
Moisture Sensitivity, Indefinite Time Out of Drypack (Note 1)	Pb-Free Pkg
	QFN-16
	Level 1
Flammability Rating	Oxygen Index: 28 to 34
	UL 94 V-0 @ 0.125 in
Transistor Count	370
Meets or exceeds JEDEC Spec EIA/JESD78 IC Latchup Test	

1. For additional Moisture Sensitivity information, refer to Application Note AND8003/D.

**Table 6. MAXIMUM RATINGS**

Symbol	Parameter	Condition 1	Condition 2	Rating	Unit
V <sub>CC</sub>	Positive Mode Power Supply	GND = 0 V		3.6	V
V <sub>I</sub>	Input Voltage	GND = 0 V	GND $\leq$ V <sub>I</sub> $\leq$ V <sub>CC</sub>	3.6	V
I <sub>SC</sub>	Output Short Circuit Current Line-to-Line Line-to-GND TIA/EIA - 644 Compliant			12 24	mA mA
I <sub>BBAC</sub>	V <sub>BBAC</sub> Sink/Source Current			$\pm$ 0.5	mA
T <sub>A</sub>	Operating Temperature Range			-40 to +85	$^{\circ}$ C
T <sub>stg</sub>	Storage Temperature Range			-65 to +150	$^{\circ}$ C
$\theta_{JA}$	Thermal Resistance (Junction-to-Ambient)	0 lfpm 500 lfpm		41.6 35.2	$^{\circ}$ C/W $^{\circ}$ C/W
$\theta_{JC}$	Thermal Resistance (Junction-to-Case)	Standard Board		4.0	$^{\circ}$ C/W
T <sub>sol</sub>	Wave Solder Pb-Free			265	$^{\circ}$ C

Stresses exceeding Maximum Ratings may damage the device. Maximum Ratings are stress ratings only. Functional operation above the Recommended Operating Conditions is not implied. Extended exposure to stresses above the Recommended Operating Conditions may affect device reliability.

# NB6N239S

**Table 7. DC CHARACTERISTICS, CLOCK INPUTS, LVDS OUTPUTS**

( $V_{CC} = 3.0\text{ V to }3.465\text{ V}$ ,  $GND = 0\text{ V}$ )

Symbol	Characteristic	-40°C			25°C			85°C			Unit
		Min	Typ	Max	Min	Typ	Max	Min	Typ	Max	
$I_{CC}$	Power Supply Current (Inputs and Outputs OPEN)				35	45	55				mA
$V_{OH}$	Output HIGH Voltage (Notes 2)			1600			1600			1600	mV
$V_{OL}$	Output LOW Voltage (Notes 2)	900			900			900			mV
$V_{OD}$	Differential Output Voltage (Figure 21)	250		450	250		450	250		450	mV
$\Delta V_{OD}$	$V_{OD}$ Magnitude Change	0		50	0		50	0		50	mV
$V_{OS}$	Offset Voltage (Figure 21)	1125		1375	1125		1375	1125		1375	mV
$\Delta V_{OS}$	$V_{OS}$ Magnitude Change	0		50	0		50	0		50	mV

**DIFFERENTIAL INPUT DRIVEN SINGLE-ENDED** (Figures 7, 10)

$V_{th}$	Input Threshold Reference Voltage (Note 3)	100		$V_{CC} - 100$	100		$V_{CC} - 100$	100		$V_{CC} - 100$	mV
$V_{IH}$	Single-ended Input HIGH Voltage	$V_{th} + 100$		$V_{CC}$	$V_{th} + 100$		$V_{CC}$	$V_{th} + 100$		$V_{CC}$	mV
$V_{IL}$	Single-ended Input LOW Voltage	GND		$V_{th} - 100$	GND		$V_{th} - 100$	GND		$V_{th} - 100$	mV
$V_{BBAC}$	Output Voltage Reference @ 100 $\mu\text{A}$ (Note 6) $V_{CC} =$	$V_{CC} - 1460$	$V_{CC} - 1330$	$V_{CC} - 1200$	$V_{CC} - 1460$	$V_{CC} - 1340$	$V_{CC} - 1200$	$V_{CC} - 1460$	$V_{CC} - 1350$	$V_{CC} - 1200$	mV
		1840	1970	2100	1840	1960	2100	1840	1950	2100	

**DIFFERENTIAL INPUT DRIVEN DIFFERENTIALLY** (Figures 8, 9, 11) (Note 5)

$V_{IHD}$	Differential Input HIGH Voltage	100		$V_{CC}$	100		$V_{CC}$	100		$V_{CC}$	mV
$V_{ILD}$	Differential Input LOW Voltage	GND		$V_{CC} - 100$	GND		$V_{CC} - 100$	GND		$V_{CC} - 100$	mV
$V_{CMR}$	Input Common Mode Range (Differential Cross-point Voltage) (Note 4)	50		$V_{CC} - 50$	50		$V_{CC} - 50$	50		$V_{CC} - 50$	mV
$V_{ID}$	Differential Input Voltage ( $V_{IHD(CLK)} - V_{ILD(CLK)}$ ) and ( $V_{IHD(CLK)} - V_{ILD(CLK)}$ )	100		$V_{CC} - GND$	100		$V_{CC} - GND$	100		$V_{CC} - GND$	mV
$R_{TIN}$	Internal Input Termination Resistor	45	50	55	45	50	55	45	50	55	$\Omega$

NOTE: Device will meet the specifications after thermal equilibrium has been established when mounted in a test socket or printed circuit board with maintained transverse airflow greater than 500 lpm. Electrical parameters are guaranteed only over the declared operating temperature range. Functional operation of the device exceeding these conditions is not implied. Device specification limit values are applied individually under normal operating conditions and not valid simultaneously.

2. Outputs loaded with 100  $\Omega$  across LVDS outputs.
3.  $V_{th}$  is applied to the complementary input when operating in single-ended mode.
4.  $V_{CMR_{MIN}}$  varies 1:1 with GND,  $V_{CMR_{MAX}}$  varies 1:1 with  $V_{CC}$ .
5. Input and output voltage swing is a single-ended measurement operating in differential mode.
6.  $V_{BBAC}$  used to rebias capacitor-coupled inputs only (see Figures 16 and 17).

# NB6N239S

**Table 8. DC CHARACTERISTICS, LVTTTL/LVCMOS INPUTS** ( $V_{CC} = 3.0\text{ V to }3.465\text{ V}$ ,  $GND = 0\text{ V}$ ,  $T_A = -40^\circ\text{C to }+85^\circ\text{C}$ )

Symbol	Characteristic	Min	Typ	Max	Unit
$V_{IH}$	Input HIGH Voltage (LVCMOS/LVTTTL)	2.0		$V_{CC}$	V
$V_{IL}$	Input LOW Voltage (LVCMOS/LVTTTL)	GND		0.8	V
$I_{IH}$	Input HIGH Current	-150		150	$\mu\text{A}$
$I_{IL}$	Input LOW Current	-150		150	$\mu\text{A}$

NOTE: Device will meet the specifications after thermal equilibrium has been established when mounted in a test socket or printed circuit board with maintained transverse airflow greater than 500 lfm. Electrical parameters are guaranteed only over the declared operating temperature range. Functional operation of the device exceeding these conditions is not implied. Device specification limit values are applied individually under normal operating conditions and not valid simultaneously.

**Table 9. AC CHARACTERISTICS**  $V_{CC} = 3.0\text{ V to }3.465\text{ V}$ ;  $GND = 0\text{ V}$  (Note 7)

Symbol	Characteristic	-40°C			25°C			85°C			Unit
		Min	Typ	Max	Min	Typ	Max	Min	Typ	Max	
$f_{inMAX}$	Maximum Input CLOCK Frequency QA/QB = ( $\div 2$ , $\div 4$ , $\div 8$ , $\div 16$ ) QA = ( $\div 1$ )	3.0 1.5			3.0 1.5			3.0 1.5			GHz
$V_{OUTPP}$	Output Voltage Amplitude (Notes 9, 10) QA ( $\div 2$ , 4, 8), QB ( $\div n$ ) QA ( $\div 1$ ), QB ( $\div n$ ) $f_{in} \leq 3.0\text{ GHz}$ $f_{in} \leq 1.5\text{ GHz}$	200 200	350 350	450 450	200 200	350 350	450 450	200 200	350 350	450 450	mV
$t_{PLH}$ , $t_{PHL}$	Propagation Delay to Output Differential @ 50 MHz CLK, Qn MR, Qn	550 420		780 660	550 420		780 660	550 420		780 660	ps
$t_{RR}$	Reset Recovery	0	-90		0	-90		0	-90		ps
$t_s$	Setup Time @ 50 MHz EN, CLK SELA/B, CLK	0 0	-60 -300		0 0	-60 -300		0 0	-60 -300		ps
$t_h$	Hold Time @ 50 MHz CLK, EN CLK, SELA/B	150 700	65 200		150 700	65 200		150 700	65 200		ps
$t_{skew}$	Within-Device Skew @ 50 MHz Device-to-Device Skew Duty Cycle Skew (Note 8) (Note 8) (Note 8)		5 25 25	30 80 40		5 30 30	30 90 45		6 30 30	35 90 45	ps
$t_{PW}$	Minimum Pulse Width MR	550			550			550			ps
$t_{JITTER}$	RMS Random Clock Jitter			2			2			2	ps
$V_{INPP}$	Input Voltage Swing (Differential Configuration) (Note 9)	100		$V_{CC}$ -GND	100		$V_{CC}$ -GND	100		$V_{CC}$ -GND	mV
$t_r$ $t_f$	Output Rise/Fall Times @ 50 MHz (20% - 80%) Qn, Qn	70	120	190	70	120	190	70	120	190	ps

NOTE: Device will meet the specifications after thermal equilibrium has been established when mounted in a test socket or printed circuit board with maintained transverse airflow greater than 500 lfm. Electrical parameters are guaranteed only over the declared operating temperature range. Functional operation of the device exceeding these conditions is not implied. Device specification limit values are applied individually under normal operating conditions and not valid simultaneously.

7. Measured using a 750 mV, 50% duty cycle clock source. All loading with 100  $\Omega$  across LVDS outputs.
8. Skew is measured between outputs under identical transitions and conditions. Duty cycle skew is defined only for differential operation when the delays are measured from the cross point of the inputs to the cross point of the outputs.
9. Input and output voltage swing is a single-ended measurement operating in differential mode.
10. Output Voltage Amplitude ( $V_{OHCLK} - V_{OLCLK}$ ) at input CLOCK frequency,  $f_{in}$ . The output frequency,  $f_{out}$ , is the input CLOCK frequency divided by n,  $f_{out} = f_{in} \div n$ . Input CLOCK frequency is  $\leq 3.0\text{ GHz}$ .

Application Information

The NB6N239S is a high-speed, low skew clock divider with two divider circuits, each having selectable clock divide ratios;  $\div 1/2/4/8$  and  $\div 2/4/8/16$ . Both divider circuits drive differential LVDS compatible outputs. The internal dividers are synchronous to each other. Therefore, the common output edges are precisely aligned.

The NB6N239S clock inputs can be driven by a variety of differential signal level technologies including LVDS, LVPECL, HCSL, HSTL, or CML. The differential clock input buffer employs a pair of internal 50  $\Omega$  termination resistors in a 100  $\Omega$  center-tapped configuration and accessible via the VT pin. This feature provides transmission line termination on-chip, at the receiver end, eliminating external components. The  $V_{BBAC}$  reference output is recommended to be used to rebias differential or

single-ended input capacitor-coupled CLOCK signals. For the capacitor-coupled CLK and/or  $\overline{CLK}$  inputs,  $V_{BBAC}$  should be connected to the  $V_T$  pin and bypassed to ground with a 0.01  $\mu F$  capacitor. Inputs CLK and  $\overline{CLK}$  must be signal driven or auto oscillation may result.

The common enable ( $\overline{EN}$ ) is synchronous so that the internal divider flip-flops will only be enabled/disabled when the internal clock is in the LOW state. This avoids any chance of generating a runt pulse on the internal clock when the device is enabled/disabled, as can happen with an asynchronous control. The internal enable flip-flop is clocked on the falling edge of the input clock. Therefore, all associated specification limits are referenced to the negative edge of the clock input.

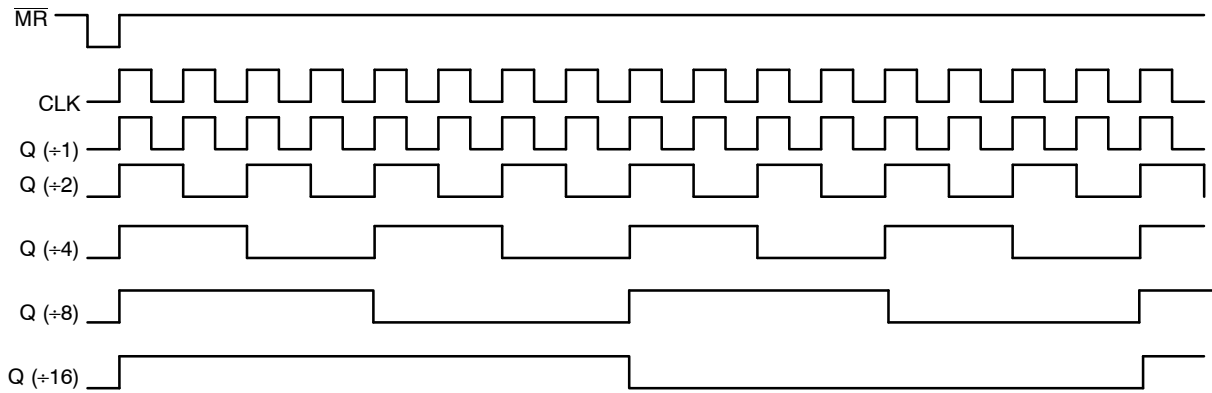
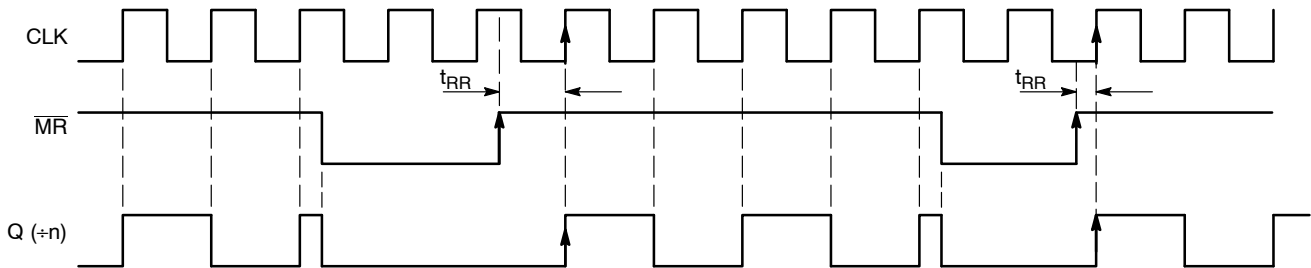


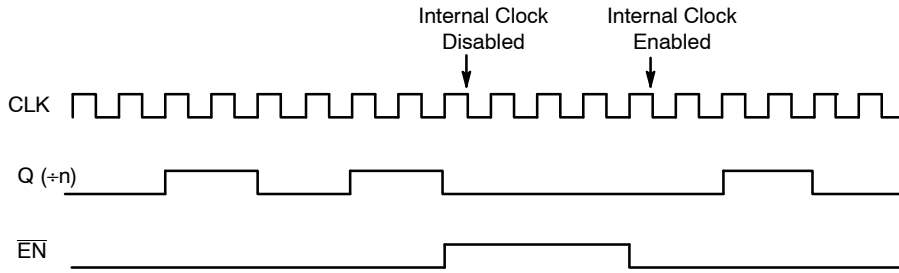
Figure 4. Timing Diagram



NOTE: On the rising edge of  $\overline{MR}$ , Q goes HIGH after the first rising edge of CLK.

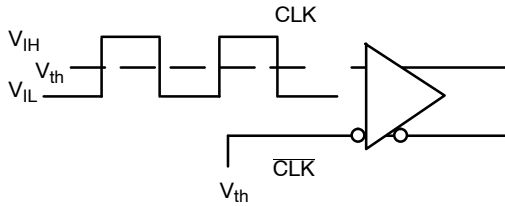
Figure 5. Master Reset Timing Diagram

# NB6N239S

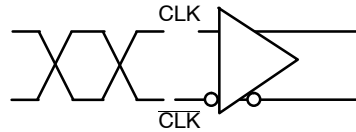


**Figure 6. Output Enable Timing Diagrams**

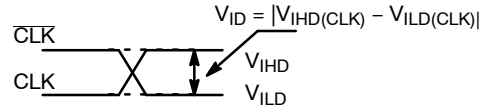
The  $\overline{EN}$  signal will “freeze” the internal divider flip-flops on the first falling edge of CLK after its assertion. The internal divider flip-flops will maintain their state during the freeze. When  $\overline{EN}$  is deasserted (LOW), and after the next falling edge of CLK, then the internal divider flip-flops will “unfreeze” and continue to their next state count with proper phase relationships.



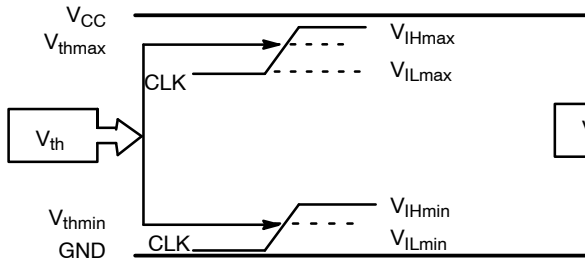
**Figure 7. Differential Input Driven Single-Ended**



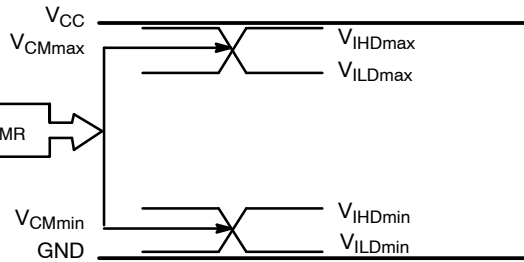
**Figure 8. Differential Inputs Driven Differentially**



**Figure 9. Differential Inputs Driven Differentially**



**Figure 10.  $V_{th}$  Diagram**



**Figure 11.  $V_{CMR}$  Diagram**

# NB6N239S

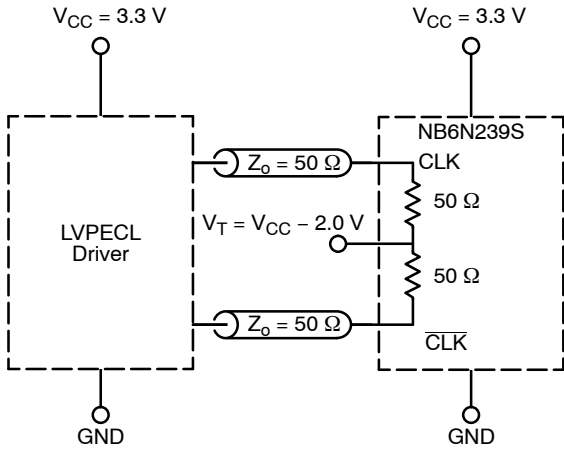


Figure 12. LVPECL Interface

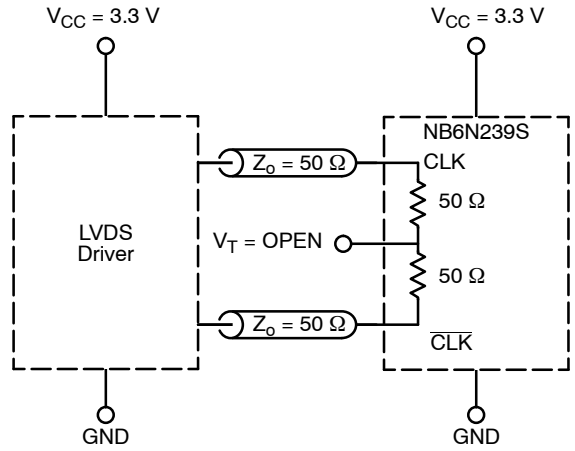


Figure 13. LVDS Interface

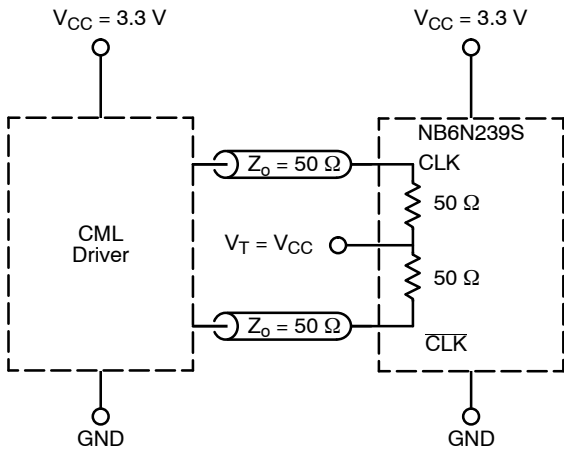


Figure 14. Standard 50 Ω Load CML Interface

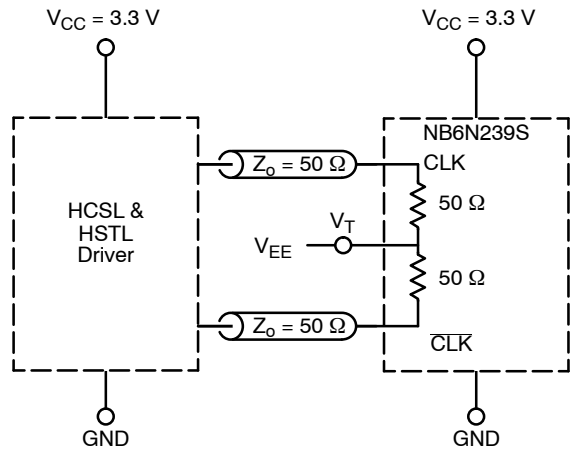


Figure 15. Standard 50 Ω Load HCSL & HSTL Interface

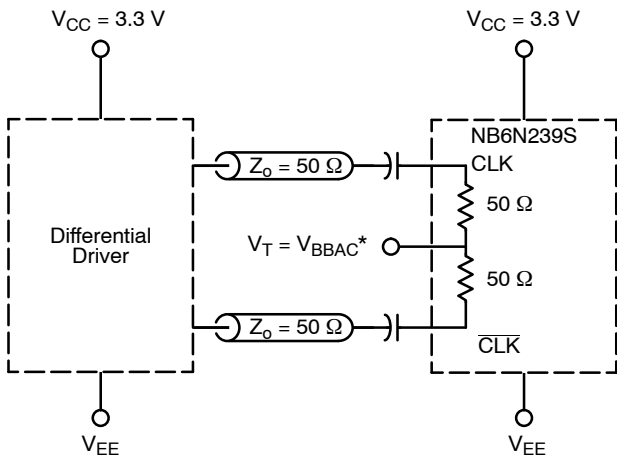


Figure 16. Capacitor-Coupled Differential Interface ( $V_T$  Connected to  $V_{BBAC}$ )

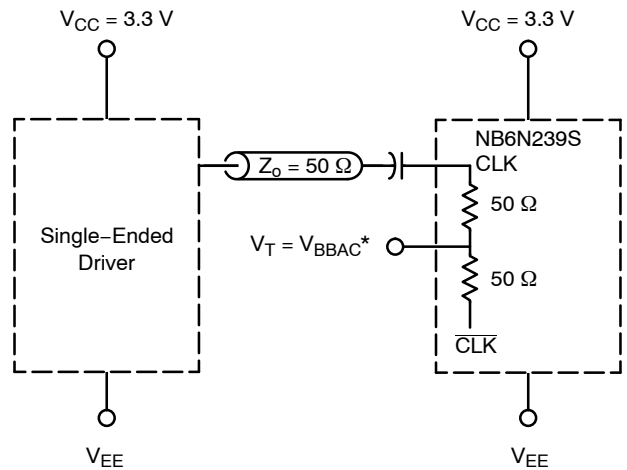
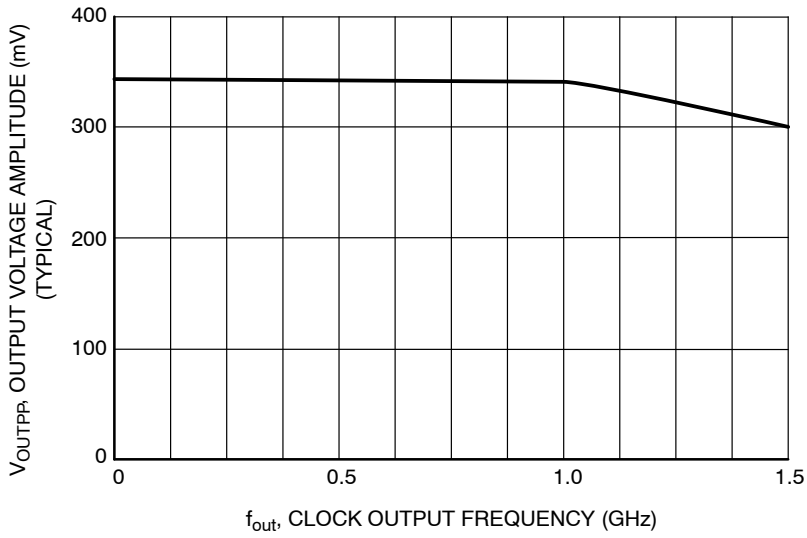


Figure 17. Capacitor-Coupled Single-Ended Interface ( $V_T$  Connected to  $V_{BBAC}$ )

\* $V_{BBAC}$  bypassed to ground with a 0.01  $\mu$ F capacitor.

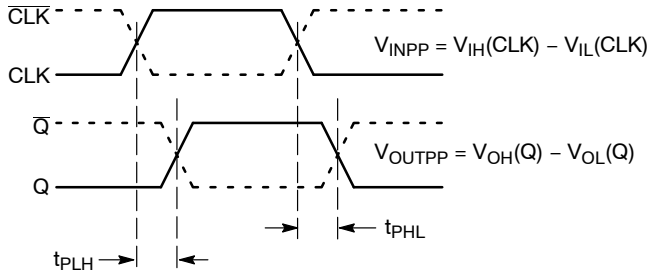
# NB6N239S



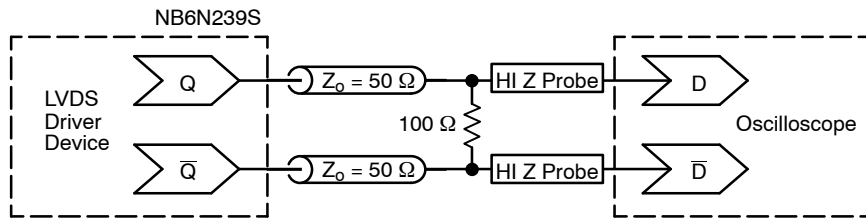
**Figure 18. Output Voltage Amplitude ( $V_{OUTPP}$ ) versus Output Clock Frequency at 25°C (Typical)**

$$f_{out} (QA/QB) = f_{in} \div n;$$

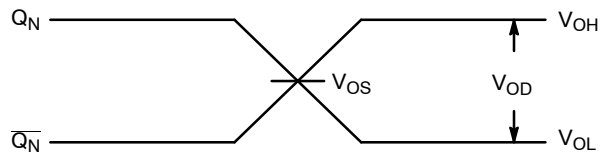
For  $n = 2, 4, 8, 16$ ;  $f_{in} \leq 3.0$  GHz  
 For  $n = 1$ ;  $f_{in} \leq 1.5$  GHz



**Figure 19. AC Reference Measurement**



**Figure 20. Typical LVDS Termination for Output Driver and Device Evaluation, If Receiver Has On-chip Termination, 100  $\Omega$  Resistor is Not Needed**



**Figure 21. LVDS Output**

# NB6N239S

## ORDERING INFORMATION

Device	Package	Shipping†
NB6N239SMNG	QFN-16, 3 x 3 mm (Pb-Free)	123 Units / Rail
NB6N239SMNR2G	QFN-16, 3 x 3 mm (Pb-Free)	3000 / Tape & Reel

†For information on tape and reel specifications, including part orientation and tape sizes, please refer to our Tape and Reel Packaging Specifications Brochure, BRD8011/D.

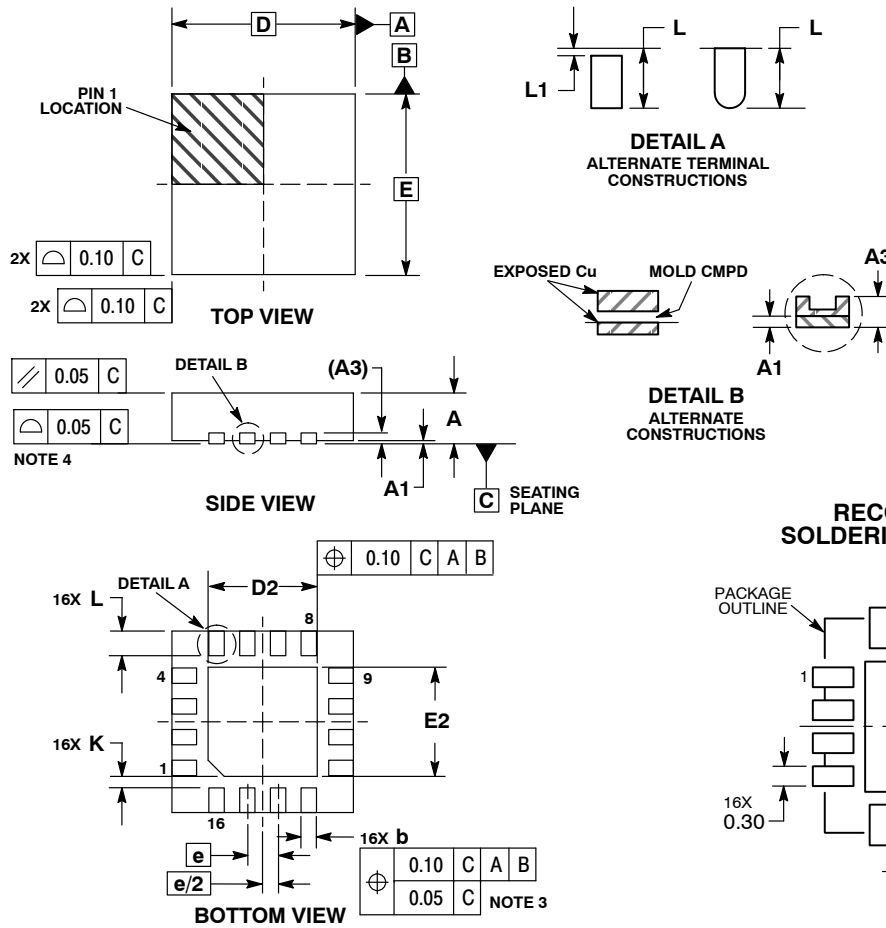
### Resource Reference of Application Notes

- AN1405/D** – ECL Clock Distribution Techniques
- AN1406/D** – Designing with PECL (ECL at +5.0 V)
- AN1503/D** – ECLinPS™ I/O SPiCE Modeling Kit
- AN1504/D** – Metastability and the ECLinPS Family
- AN1568/D** – Interfacing Between LVDS and ECL
- AN1672/D** – The ECL Translator Guide
- AND8001/D** – Odd Number Counters Design
- AND8002/D** – Marking and Date Codes
- AND8020/D** – Termination of ECL Logic Devices
- AND8066/D** – Interfacing with ECLinPS
- AND8090/D** – AC Characteristics of ECL Devices

# NB6N239S

## PACKAGE DIMENSIONS

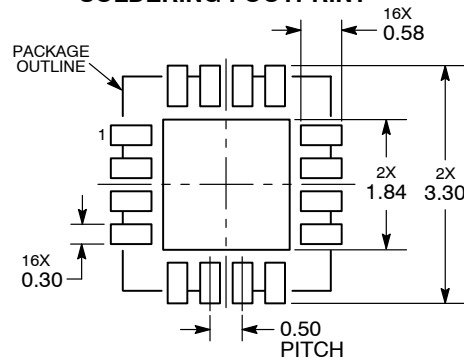
QFN16 3x3, 0.5P  
CASE 485G  
ISSUE F



**NOTES:**

1. DIMENSIONING AND TOLERANCING PER ASME Y14.5M, 1994.
2. CONTROLLING DIMENSION: MILLIMETERS.
3. DIMENSION b APPLIES TO PLATED TERMINAL AND IS MEASURED BETWEEN 0.25 AND 0.30 MM FROM TERMINAL.
4. COPLANARITY APPLIES TO THE EXPOSED PAD AS WELL AS THE TERMINALS.

**RECOMMENDED SOLDERING FOOTPRINT\***



DIMENSIONS: MILLIMETERS

\*For additional information on our Pb-Free strategy and soldering details, please download the ON Semiconductor Soldering and Mounting Techniques Reference Manual, SOLDERRM/D.

ECLinPS and ECLinPS MAX are trademarks of Semiconductor Components Industries, LLC (SCILLC).

ON Semiconductor and are registered trademarks of Semiconductor Components Industries, LLC (SCILLC). SCILLC owns the rights to a number of patents, trademarks, copyrights, trade secrets, and other intellectual property. A listing of SCILLC's product/patent coverage may be accessed at [www.onsemi.com/site/pdf/Patent-Marking.pdf](http://www.onsemi.com/site/pdf/Patent-Marking.pdf). SCILLC reserves the right to make changes without further notice to any products herein. SCILLC makes no warranty, representation or guarantee regarding the suitability of its products for any particular purpose, nor does SCILLC assume any liability arising out of the application or use of any product or circuit, and specifically disclaims any and all liability, including without limitation special, consequential or incidental damages. "Typical" parameters which may be provided in SCILLC data sheets and/or specifications can and do vary in different applications and actual performance may vary over time. All operating parameters, including "Typicals" must be validated for each customer application by customer's technical experts. SCILLC does not convey any license under its patent rights nor the rights of others. SCILLC products are not designed, intended, or authorized for use as components in systems intended for surgical implant into the body, or other applications intended to support or sustain life, or for any other application in which the failure of the SCILLC product could create a situation where personal injury or death may occur. Should Buyer purchase or use SCILLC products for any such unintended or unauthorized application, Buyer shall indemnify and hold SCILLC and its officers, employees, subsidiaries, affiliates, and distributors harmless against all claims, costs, damages, and expenses, and reasonable attorney fees arising out of, directly or indirectly, any claim of personal injury or death associated with such unintended or unauthorized use, even if such claim alleges that SCILLC was negligent regarding the design or manufacture of the part. SCILLC is an Equal Opportunity/Affirmative Action Employer. This literature is subject to all applicable copyright laws and is not for resale in any manner.

**PUBLICATION ORDERING INFORMATION**

**LITERATURE FULFILLMENT:**  
Literature Distribution Center for ON Semiconductor  
P.O. Box 5163, Denver, Colorado 80217 USA  
**Phone:** 303-675-2175 or 800-344-3860 Toll Free USA/Canada  
**Fax:** 303-675-2176 or 800-344-3867 Toll Free USA/Canada  
**Email:** [orderlit@onsemi.com](mailto:orderlit@onsemi.com)

**N. American Technical Support:** 800-282-9855 Toll Free  
USA/Canada  
**Europe, Middle East and Africa Technical Support:**  
Phone: 421 33 790 2910  
**Japan Customer Focus Center**  
Phone: 81-3-5817-1050

**ON Semiconductor Website:** [www.onsemi.com](http://www.onsemi.com)  
**Order Literature:** <http://www.onsemi.com/orderlit>  
For additional information, please contact your local Sales Representative

## Looking for pricing, stock, or lifecycle information?

Click below to explore more details on WIN SOURCE:

- ⊖ [View NB6N239SMNR2G on WIN SOURCE](#)
- ⊖ [ON Semiconductor Information](#)

## Optimize Your Supply Chain with WIN SOURCE Solutions

- ✓ Global Sourcing Solution
- ✓ Obsolete Management
- ✓ Cost Control Management
- ✓ Shortage Management
- ✓ Alternative Solution
- ✓ Excess Inventory Management