



**THE DATASHEET OF
NB4L52MNR2G**



NB4L52

2.5 V/3.3 V/5.0 V Differential Data/Clock D Flip-Flop with Reset

Multi-Level Inputs to LVPECL Translator w/ Internal Termination

The NB4L52 is a differential Data and Clock D flip-flop with a differential asynchronous Reset. The differential inputs incorporate internal 50 Ω termination resistors and will accept PECL, LVPECL, LVCMOS, LVTTTL, CML, or LVDS logic levels. When Clock transitions from Low to High, Data will be transferred to the differential LVPECL outputs. The differential Clock inputs allow the NB4L52 to also be used as a negative edge triggered device. The device is housed in a small 3x3 mm 16 pin QFN package.

Features

- Maximum Input Clock Frequency > 4 GHz Typical
- 330 ps Typical Propagation Delay
- 145 ps Typical Rise and Fall Times
- Differential LVPECL Outputs, 750 mV Peak-to-Peak, Typical
- Operating Range: $V_{CC} = 2.375\text{ V}$ to 5.5 V with $V_{EE} = 0\text{ V}$
- Internal Input Termination Resistors, 50 Ω
- Functionally Compatible with Existing 2.5 V/3.3 V/5.0 V LVPECL, LVEP, EP, and SG Devices
- -40°C to $+85^{\circ}\text{C}$ Ambient Operating Temperature
- These are Pb-Free Devices



ON Semiconductor®

<http://onsemi.com>

MARKING DIAGRAM*



QFN-16
MN SUFFIX
CASE 485G

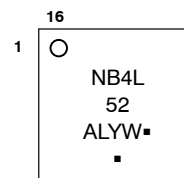

- A = Assembly Location
- L = Wafer Lot
- Y = Year
- W = Work Week
- = Pb-Free Package

(Note: Microdot may be in either location)

*For additional marking information, refer to Application Note AND8002/D.

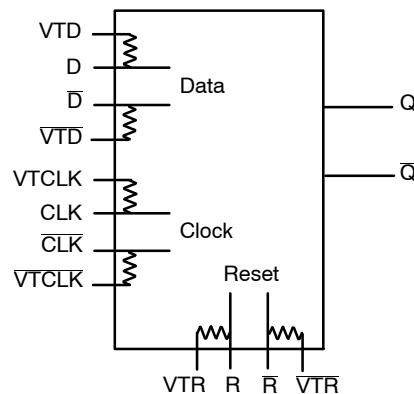

Figure 1. Logic Diagram

Table 1. TRUTH TABLE

| R | D | CLK | Q |
|---|---|-----|---|
| H | x | x | L |
| L | L | Z | L |
| L | H | Z | H |

Z = LOW to HIGH Transition
x = Don't Care

ORDERING INFORMATION

See detailed ordering and shipping information in the package dimensions section on page 7 of this data sheet.

NB4L52

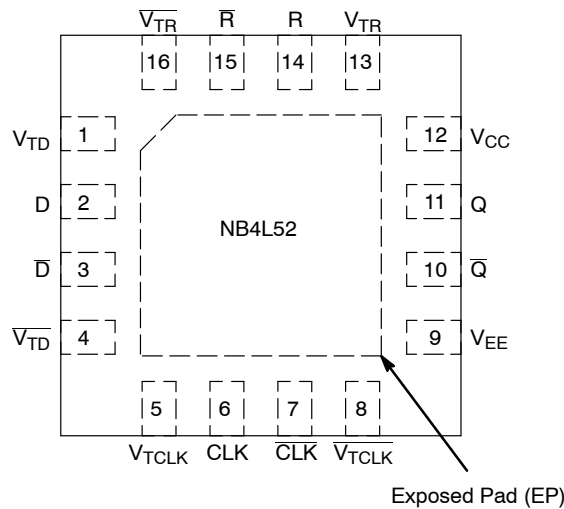

Figure 2. Pinout (Top View)

Table 2. PIN DESCRIPTION

| Pin | Name | I/O | Description |
|-----|-----------------------|--------------------------------------|---|
| 1 | $\overline{V_{TD}}$ | - | Internal 50 Ω Termination Pin. (See Table 4) |
| 2 | D | ECL, CML, LVCMOS, LVDS, LVTTTL Input | Noninverted Differential Input. (Note 1) |
| 3 | \overline{D} | ECL, CML, LVCMOS, LVDS, LVTTTL Input | Inverted Differential Input. (Note 1) |
| 4 | $\overline{V_{TD}}$ | - | Internal 50 Ω Termination Pin. (See Table 4) |
| 5 | $\overline{V_{TCLK}}$ | - | Internal 50 Ω Termination Pin. (See Table 4) |
| 6 | CLK | ECL, CML, LVCMOS, LVDS, LVTTTL Input | Noninverted Differential Input. (Note 1) |
| 7 | \overline{CLK} | ECL, CML, LVCMOS, LVDS, LVTTTL Input | Inverted Differential Input. (Note 1) |
| 8 | $\overline{V_{TCLK}}$ | - | Internal 50 Ω Termination Pin. (See Table 4) |
| 9 | V_{EE} | - | Negative Supply Voltage |
| 10 | \overline{Q} | ECL Output | Inverted Differential Output. Typically terminated with 50 Ω resistor to $V_{CC} - 2.0$ V. |
| 11 | Q | ECL Output | Noninverted Differential Output. Typically terminated with 50 Ω resistor to $V_{CC} - 2.0$ V. |
| 12 | V_{CC} | - | Positive Supply Voltage |
| 13 | $\overline{V_{TR}}$ | - | Internal 50 Ω Termination Pin. (See Table 4) |
| 14 | R | LVECL, LVCMOS, LVTTTL Input | Noninverted Differential Reset Input. (Note 1) |
| 15 | \overline{R} | LVECL, LVCMOS, LVTTTL Input | Inverted Differential Reset Input. (Note 1) |
| 16 | $\overline{V_{TR}}$ | - | Internal 50 Ω Termination Pin. (See Table 4) |
| - | EP | - | The Exposed Pad (EP) on the QFN-16 package bottom is thermally connected to the die for improved heat transfer out of package. The pad is not electrically connected to the die, but is recommended to be electrically and thermally connected to V_{EE} on the PC board. |

1. In the differential configuration when the input termination pin ($\overline{V_{TD}}$, $\overline{V_{TD}}$, $\overline{V_{TR}}$, $\overline{V_{TR}}$, $\overline{V_{TCLK}}$, $\overline{V_{TCLK}}$) are connected to a common termination voltage or left open, and if no signal is applied on D/ \overline{D} , CLK/ \overline{CLK} , R/ \overline{R} input then the device will be susceptible to self-oscillation.

NB4L52

Table 3. ATTRIBUTES

| Characteristic | Value | |
|--|---|-----------------------------|
| ESD Protection | Human Body Model Machine Model Charged Device Model | > 2 kV > 200 V > 1 kV |
| Moisture Sensitivity (Note 2) | Pb Pkg | Pb-Free Pkg |
| | QFN-16 | Level 1 Level 1 |
| Flammability Rating Oxygen Index: 28 to 34 | UL 94 V-0 @ 0.125 in | |
| Transistor Count | 164 | |
| Meets or exceeds JEDEC Spec EIA/JESD78 IC Latchup Test | | |

2. For additional information, see Application Note AND8003/D.

Table 4. MAXIMUM RATINGS

| Symbol | Parameter | Condition 1 | Condition 2 | Rating | Unit |
|---------------|--|--|--|-------------|--|
| V_{CC} | Positive Power Supply | $V_{EE} = 0\text{ V}$ | | 6.0 | V |
| V_{EE} | Negative Power Supply | $V_{CC} = 0\text{ V}$ | | -6.0 | V |
| V_{IO} | Positive Input/Output Negative Input/Output | $V_{EE} = 0\text{ V}$ $V_{CC} = 0\text{ V}$ | $V_I \leq V_{CC}$ $V_I \geq V_{EE}$ | 6.0 -6.0 | V V |
| I_{IN} | Input Current Through R_T (50 Ω Resistor) | Static Surge | | 45 80 | mA mA |
| I_{out} | Output Current | Continuous Surge | | 25 50 | mA mA |
| T_A | Operating Temperature Range | | | -40 to +85 | $^{\circ}\text{C}$ |
| T_{stg} | Storage Temperature Range | | | -65 to +150 | $^{\circ}\text{C}$ |
| θ_{JA} | Thermal Resistance (Junction-to-Ambient) | 0 LFPM 500 LFPM | 16 QFN 16 QFN | 42 35 | $^{\circ}\text{C}/\text{W}$ $^{\circ}\text{C}/\text{W}$ |
| θ_{JC} | Thermal Resistance (Junction-to-Case) | 2S2P (Note 3) | 16 QFN | 4.0 | $^{\circ}\text{C}/\text{W}$ |
| T_{sol} | Wave Solder Pb-Free | | | 265 | $^{\circ}\text{C}$ |

Stresses exceeding Maximum Ratings may damage the device. Maximum Ratings are stress ratings only. Functional operation above the Recommended Operating Conditions is not implied. Extended exposure to stresses above the Recommended Operating Conditions may affect device reliability.

3. JEDEC standard multilayer board – 2S2P (2 signal, 2 power) with 8 filled thermal vias under exposed pad.

NB4L52

Table 5. DC CHARACTERISTICS, CLOCK INPUTS, LVPECL OUTPUTS

($V_{CC} = 2.375\text{ V to }5.5\text{ V}$, $V_{EE} = 0\text{ V or }V_{CC} = 0\text{ V}$, $V_{EE} = -2.375\text{ to }-5.5\text{ V}$, $T_A = -40^\circ\text{C to }+85^\circ\text{C}$)

| Symbol | Characteristic | Min | Typ | Max | Unit |
|----------|--|---|---|--|------|
| I_{EE} | Power Supply Current (Inputs and Outputs Open) | | 16 | 25 | mA |
| V_{OH} | Output HIGH Voltage (Note 4, 5) $V_{CC} = 5.0\text{ V}$ $V_{CC} = 3.3\text{ V}$ $V_{CC} = 2.5\text{ V}$ | $V_{CC} - 1145$ 3855 2155 1355 | $V_{CC} - 1020$ 3980 2280 1480 | $V_{CC} - 895$ 4105 2405 1605 | mV |
| V_{OL} | Output LOW Voltage (Note 4, 5) $V_{CC} = 5.0\text{V}$ $V_{CC} = 3.3\text{V}$ $V_{CC} = 2.5\text{V}$ | $V_{CC} - 1945$ 3055 1355 555 | $V_{CC} - 1770$ 3230 1530 730 | $V_{CC} - 1600$ 3400 1700 900 | mV |

DIFFERENTIAL INPUT DRIVEN SINGLE-ENDED (Figures 4 & 7)

| | | | | | |
|----------|--|----------------|--|----------------|----|
| V_{th} | Input Threshold Reference Voltage Range (Note 6) | 1050 | | $V_{CC} - 150$ | mV |
| V_{IH} | Single-ended Input HIGH Voltage | $V_{th} + 150$ | | V_{CC} | mV |
| V_{IL} | Single-ended Input LOW Voltage | V_{EE} | | $V_{th} - 150$ | mV |

DIFFERENTIAL INPUT DRIVEN DIFFERENTIALLY (Figures 5, 6 & 8)

| | | | | | |
|-----------|--|----------|----|----------------|---------------|
| V_{IHD} | Differential Input HIGH Voltage | 1200 | | V_{CC} | mV |
| V_{ILD} | Differential Input LOW Voltage | V_{EE} | | $V_{CC} - 150$ | mV |
| V_{CMR} | Input Common Mode Range (Differential Configuration) (Note 7) | 1125 | | $V_{CC} - 75$ | mV |
| V_{ID} | Differential Input Voltage ($V_{IHD} - V_{ILD}$) | 150 | | V_{CC} | mV |
| I_{IH} | Input HIGH Current D / \bar{D} , CLK / \bar{CLK} , R / \bar{R} (V_{Tx}/\bar{V}_{Tx} Open) | -150 | | 150 | μA |
| I_{IL} | Input LOW Current D / \bar{D} , CLK / \bar{CLK} , R / \bar{R} (V_{Tx}/\bar{V}_{Tx} Open) | -150 | | 150 | μA |
| R_{TIN} | Internal Input Termination Resistor | 40 | 50 | 60 | Ω |

NOTE: Device will meet the specifications after thermal equilibrium has been established when mounted in a test socket or printed circuit board with maintained transverse airflow greater than 500 lfm. Electrical parameters are guaranteed only over the declared operating temperature range. Functional operation of the device exceeding these conditions is not implied. Device specification limit values are applied individually under normal operating conditions and not valid simultaneously.

4. LVPECL outputs loaded with $50\ \Omega$ to $V_{CC} - 2.0\text{ V}$ for proper operation.
5. Input and output parameters vary 1:1 with V_{CC} .
6. V_{th} is applied to the complementary input when operating in single-ended mode.
7. V_{CMRMIN} varies 1:1 with V_{EE} , V_{CMRMAX} varies 1:1 with V_{CC} . The V_{CMR} range is referenced to the most positive side of the differential input signal.

NB4L52

Table 6. AC CHARACTERISTICS $V_{CC} = 2.375\text{ V to }5.5\text{ V}$; $V_{EE} = 0\text{ V or }V_{CC} = 0\text{ V}$, $V_{EE} = -2.375\text{ to }-5.5\text{ V}$ (Note 8)

| Symbol | Characteristic | -40°C | | | 25°C | | | 85°C | | | Unit |
|--------------------------|---|-------|-----|------|------|-----|------|------|-----|------|------|
| | | Min | Typ | Max | Min | Typ | Max | Min | Typ | Max | |
| V_{OUTPP} | Output Voltage Amplitude (@ $V_{INPPmin}$) (Note 10) (See Figure 4) $f_{in} \leq 2.0\text{ GHz}$ $f_{in} \leq 3.0\text{ GHz}$ $f_{in} \leq 4.0\text{ GHz}$ | 530 | 770 | | 530 | 780 | | 530 | 760 | | mV |
| t_{PLH} , t_{PHL} | Propagation Delay to Output Differential CLK to Q, R to Q | 300 | 400 | 500 | 300 | 400 | 500 | 300 | 400 | 500 | ps |
| t_s | Setup Time | 100 | | | 100 | | | 100 | | | ps |
| t_h | Hold Time | 50 | | | 50 | | | 50 | | | ps |
| t_{RR} | Reset Recovery | 400 | | | 400 | | | 400 | | | ps |
| t_{PW} | Minimum Pulse Width R/R | 250 | | | 250 | | | 250 | | | ps |
| t_{JITTER} | RMS Random Clock Jitter (Note 9) $f_{in} \leq 2.0\text{ GHz}$ $f_{in} \leq 3.0\text{ GHz}$ $f_{in} \leq 4.0\text{ GHz}$ | | 1 | | | 1 | | | 1 | | ps |
| V_{INPP} | Input Voltage Swing/Sensitivity (Differential Configuration) (Note 10) | 150 | | 2800 | 150 | | 2800 | 150 | | 2800 | mV |
| t_r t_f | Output Rise/Fall Times @ 0.5 GHz (20% – 80%) | 80 | 135 | 190 | 80 | 145 | 190 | 80 | 155 | 190 | ps |

NOTE: Device will meet the specifications after thermal equilibrium has been established when mounted in a test socket or printed circuit board with maintained transverse airflow greater than 500 lfm. Electrical parameters are guaranteed only over the declared operating temperature range. Functional operation of the device exceeding these conditions is not implied. Device specification limit values are applied individually under normal operating conditions and not valid simultaneously.

8. Measured by forcing V_{INPP} (MIN) from a 50% duty cycle clock source. All loading with an external $R_L = 50\ \Omega$ to $V_{CC} - 2.0\text{ V}$. Input edge rates 40 ps (20% – 80%).
9. Additive RMS jitter with 50% duty cycle clock signal.
10. Input and output voltage swing is a single-ended measurement operating in differential mode.

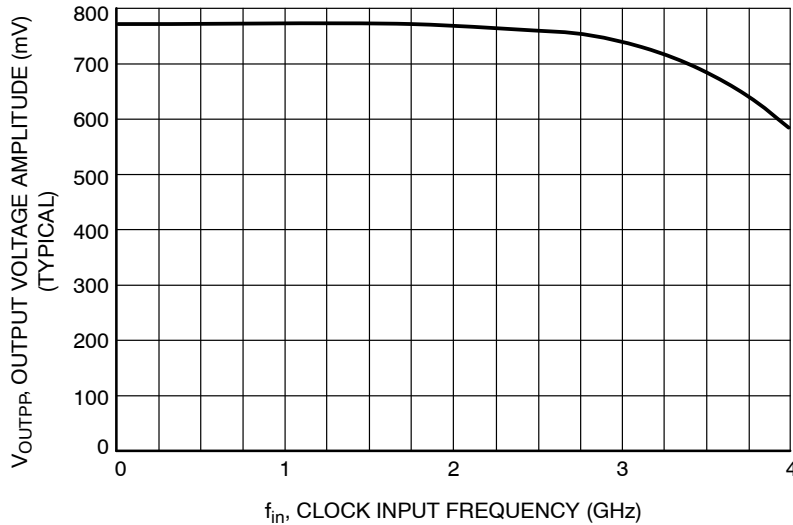

Figure 3. Output Voltage Amplitude (V_{OUTPP}) vs. Clock Input Frequency at Ambient Temperature (Typical).

NB4L52

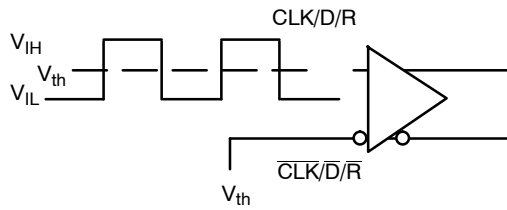

Figure 4. Differential Input Driven Single-Ended

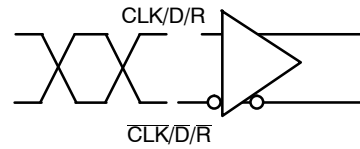

Figure 5. Differential Inputs Driven Differentially

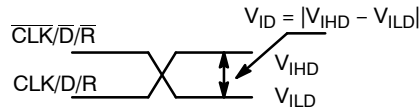

Figure 6. Differential Inputs Driven Differentially

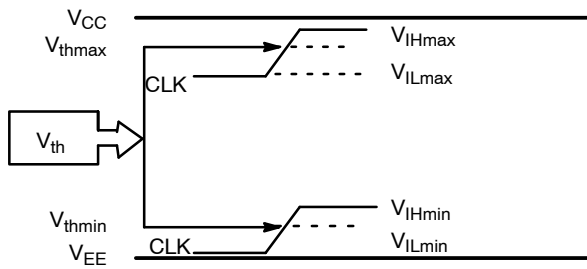

Figure 7. V_{th} Diagram

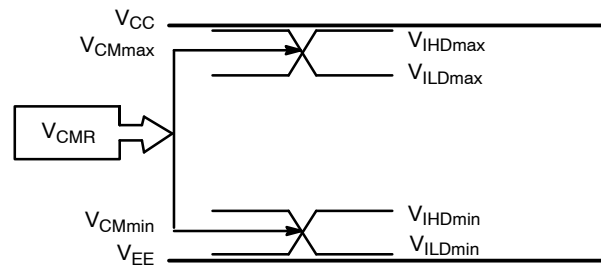

Figure 8. V_{CMR} Diagram

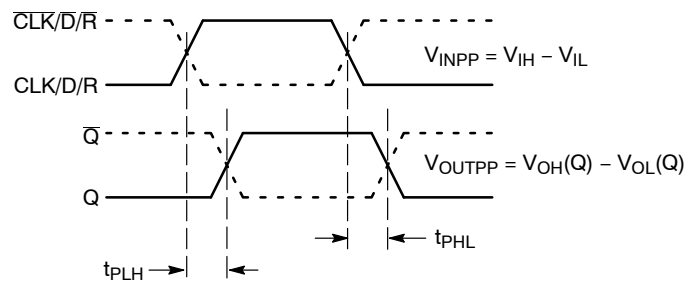

Figure 9. AC Reference Measurement

NB4L52

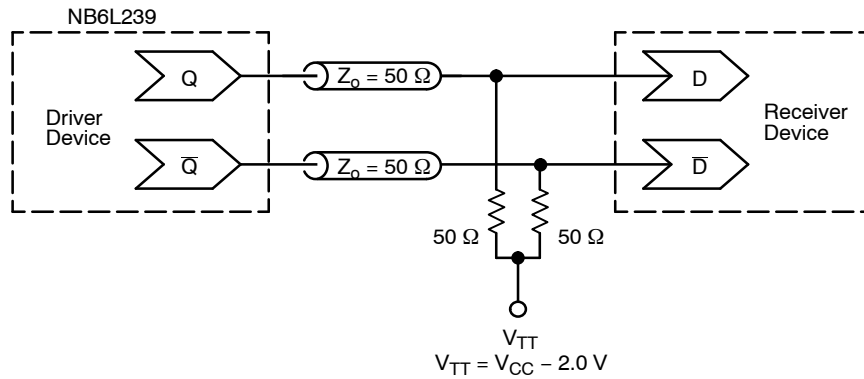

Figure 10. Typical Termination for Output Driver and Device Evaluation
 (See Application Note AND8020/D – Termination of ECL Logic Devices.)

ORDERING INFORMATION

| Device | Package | Shipping† |
|-------------|-------------------------------|--------------------|
| NB4L52MNG | QFN-16, 3 x 3 mm (Pb-Free) | 123 Units / Rail |
| NB4L52MNR2G | QFN-16, 3 x 3 mm (Pb-Free) | 3000 / Tape & Reel |

†For information on tape and reel specifications, including part orientation and tape sizes, please refer to our Tape and Reel Packaging Specifications Brochure, BRD8011/D.

Resource Reference of Application Notes

- AN1405/D** – ECL Clock Distribution Techniques
- AN1406/D** – Designing with PECL (ECL at +5.0 V)
- AN1503/D** – ECLinPS I/O SPICE Modeling Kit
- AN1504/D** – Metastability and the ECLinPS Family
- AN1568/D** – Interfacing Between LVDS and ECL
- AN1672/D** – The ECL Translator Guide
- AND8001/D** – Odd Number Counters Design
- AND8002/D** – Marking and Date Codes
- AND8020/D** – Termination of ECL Logic Devices
- AND8066/D** – Interfacing with ECLinPS
- AND8090/D** – AC Characteristics of ECL Devices

NB4L52

PACKAGE DIMENSIONS

16 PIN QFN CASE 485G-01 ISSUE D

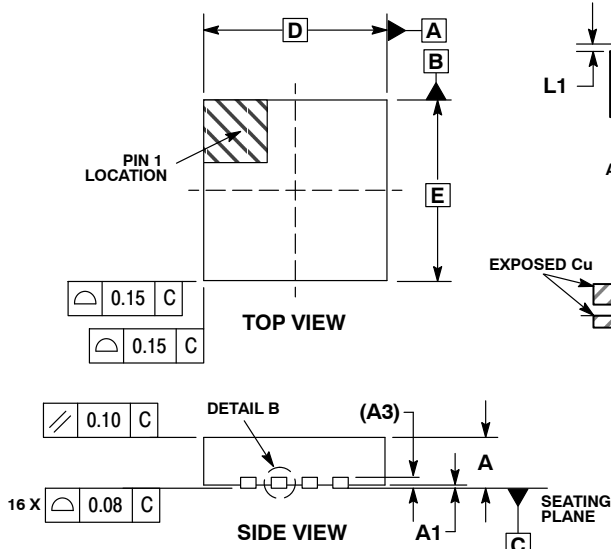

NOTES:

1. DIMENSIONING AND TOLERANCING PER ASME Y14.5M, 1994.
2. CONTROLLING DIMENSION: MILLIMETERS.
3. DIMENSION b APPLIES TO PLATED TERMINAL AND IS MEASURED BETWEEN 0.25 AND 0.30 MM FROM TERMINAL.
4. COPLANARITY APPLIES TO THE EXPOSED PAD AS WELL AS THE TERMINALS.
5. L_{max} CONDITION CAN NOT VIOLATE 0.2 MM MINIMUM SPACING BETWEEN LEAD TIP AND FLAG

| MILLIMETERS | | |
|-------------|------|------|
| DIM | MIN | MAX |
| A | 0.80 | 1.00 |
| A1 | 0.00 | 0.05 |
| A3 | 0.20 | REF |
| b | 0.18 | 0.30 |
| D | 3.00 | BSC |
| D2 | 1.65 | 1.85 |
| E | 3.00 | BSC |
| E2 | 1.65 | 1.85 |
| e | 0.50 | BSC |
| K | 0.18 | TYP |
| L | 0.30 | 0.50 |
| L1 | 0.00 | 0.15 |

SOLDERING FOOTPRINT*

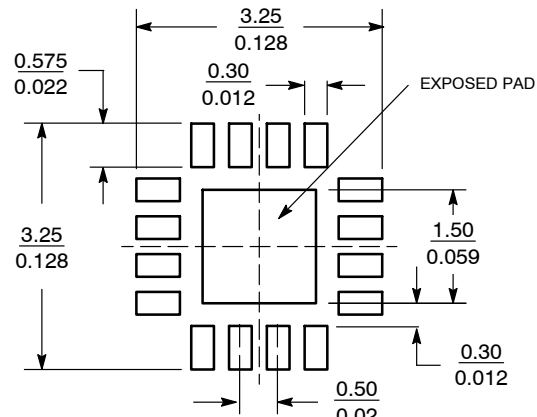
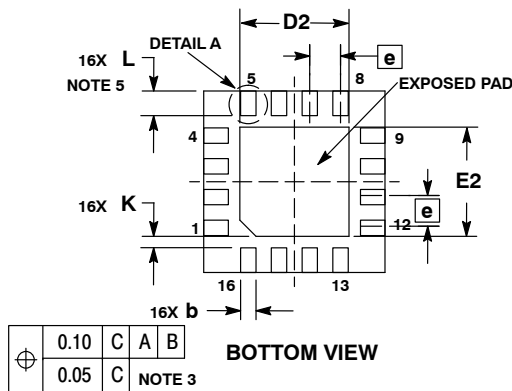

*For additional information on our Pb-Free strategy and soldering details, please download the ON Semiconductor Soldering and Mounting Techniques Reference Manual, SOLDERRM/D.

The products described herein (NB4L52), may be covered by U.S. patents including 6,362,644. There may be other patents pending.

ON Semiconductor and are registered trademarks of Semiconductor Components Industries, LLC (SCILLC). SCILLC reserves the right to make changes without further notice to any products herein. SCILLC makes no warranty, representation or guarantee regarding the suitability of its products for any particular purpose, nor does SCILLC assume any liability arising out of the application or use of any product or circuit, and specifically disclaims any and all liability, including without limitation special, consequential or incidental damages. "Typical" parameters which may be provided in SCILLC data sheets and/or specifications can and do vary in different applications and actual performance may vary over time. All operating parameters, including "Typicals" must be validated for each customer application by customer's technical experts. SCILLC does not convey any license under its patent rights nor the rights of others. SCILLC products are not designed, intended, or authorized for use as components in systems intended for surgical implant into the body, or other applications intended to support or sustain life, or for any other application in which the failure of the SCILLC product could create a situation where personal injury or death may occur. Should Buyer purchase or use SCILLC products for any such unintended or unauthorized application, Buyer shall indemnify and hold SCILLC and its officers, employees, subsidiaries, affiliates, and distributors harmless against all claims, costs, damages, and expenses, and reasonable attorney fees arising out of, directly or indirectly, any claim of personal injury or death associated with such unintended or unauthorized use, even if such claim alleges that SCILLC was negligent regarding the design or manufacture of the part. SCILLC is an Equal Opportunity/Affirmative Action Employer. This literature is subject to all applicable copyright laws and is not for resale in any manner.

PUBLICATION ORDERING INFORMATION

LITERATURE FULFILLMENT:
Literature Distribution Center for ON Semiconductor
P.O. Box 5163, Denver, Colorado 80217 USA
Phone: 303-675-2175 or 800-344-3860 Toll Free USA/Canada
Fax: 303-675-2176 or 800-344-3867 Toll Free USA/Canada
Email: orderlit@onsemi.com

N. American Technical Support: 800-282-9855 Toll Free USA/Canada
Europe, Middle East and Africa Technical Support:
Phone: 421 33 790 2910
Japan Customer Focus Center
Phone: 81-3-5773-3850

ON Semiconductor Website: www.onsemi.com
Order Literature: <http://www.onsemi.com/orderlit>
For additional information, please contact your local Sales Representative

Looking for pricing, stock, or lifecycle information?

Click below to explore more details on WIN SOURCE:

- ⊖ [View NB4L52MNR2G on WIN SOURCE](#)
- ⊖ [ON Semiconductor Information](#)

Optimize Your Supply Chain with WIN SOURCE Solutions

- ✓ Global Sourcing Solution
- ✓ Obsolete Management
- ✓ Cost Control Management
- ✓ Shortage Management
- ✓ Alternative Solution
- ✓ Excess Inventory Management