



**THE DATASHEET OF  
NB3N511DR2G**



# NB3N511

## 3.3V / 5.0V 4 MHz to 200 MHz PLL Clock Multiplier



ON Semiconductor®

[www.onsemi.com](http://www.onsemi.com)

### Description

The NB3N511 is a clock multiplier that will generate one of nine selectable output multiples of an input frequency via two 3-level select inputs (S0, S1). It accepts a standard fundamental mode crystal or an external reference clock signal. Phase-Locked-Loop (PLL) design techniques are used to produce a low jitter, TTL level clock output up to 200 MHz with a 50% duty cycle. An Output Enable (OE) pin is provided, and when asserted low, the clock output goes into tri-state (high impedance). The NB3N511 is commonly used in electronic systems as a cost efficient replacement for crystal oscillators

### Features

- Clock Output Frequencies up to 200 MHz
- Nine Selectable Multipliers of the Input Frequency
- Operating Range:  $V_{DD} = 3.3\text{ V} \pm 10\%$  or  $5.0\text{ V} \pm 5\%$
- Low Jitter Output of 25 ps One Sigma (rms)
- Zero ppm Clock Multiplication Error
- 45% – 55% Output Duty Cycle
- TTL/CMOS Output with 25 mA TTL Level Drive
- Crystal Reference Input Range of 5 – 32 MHz
- Input Clock Frequency Range of 1 – 50 MHz
- OE, Output Enable with Tri-State Output
- 8-Pin SOIC
- Industrial Temperature Range  $-40^{\circ}\text{C}$  to  $+85^{\circ}\text{C}$
- These are Pb-Free Devices

### MARKING DIAGRAM

8  
1  
SOIC-8  
D SUFFIX  
CASE 751

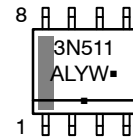

3N511 = Specific Device Code  
A = Assembly Location  
L = Wafer Lot  
Y = Year  
W = Work Week  
▪ = Pb-Free Package

### ORDERING INFORMATION

See detailed ordering and shipping information in the package dimensions section on page 5 of this data sheet.

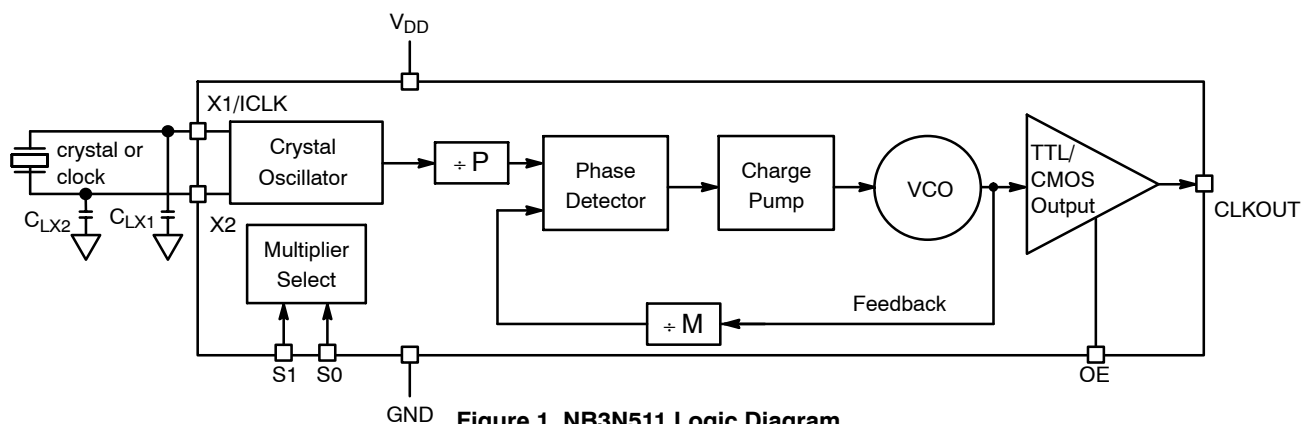

Figure 1. NB3N511 Logic Diagram

# NB3N511

**Table 1. CLOCK MULTIPLIER SELECT TABLE**

S1*	S0*	CLKOUT Multiplier
L	L	4X Input
L	M	5.333X Input
L	H	5X Input
M	L	2.5X Input
M	M	2X Input
M	H	3.333X Input
H	L	6X Input
H	M	3X Input
H	H	8X Input

\*Pins S1 and S0 default to M when open

L = GND

H = VDD

M = OPEN (unconnected; will default to VDD/2)

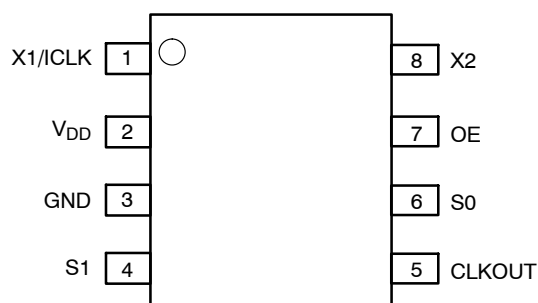

**Figure 2. NB3N511 Package Pinout, 8-Pin (150 mil) SOIC (Top View)**

**Table 2. PIN DESCRIPTION**

Pin #	Name	I/O	Description
1	X1/ICLK	Crystal or LVCMOS/LVTTL Input	Crystal or external reference clock input
2	VDD	Power supply	Positive supply voltage
3	GND	Power supply	0 V. Ground.
4	S1	Three level Input	Multiplier select pin – connect to V <sub>DD</sub> , GND or float
5	CLKOUT	LVCMOS/LVTTL Output	Clock output
6	S0	Three level Input	Multiplier select pin – connect to V <sub>DD</sub> , GND or float
7	OE	LVCMOS/LVTTL Input	Output Enable. CLKOUT is high impedance when OE is low. Internal pullup
8	X2	Crystal	Crystal input – Leave open when providing an external clock reference

**Table 3. COMMON OUTPUT FREQUENCY EXAMPLES**

Output Frequency (MHz)	Input Frequency (MHz)	S1, S0
20	10	M, M
24	12	M, M
30	10	H, M
32	16	M, M
33.33	16.66	M, M
37.5	15	M, L
40	10	L, L
48	12	L, L
50	20	M, L
60	10	H, L
64	16	L, L

**Table 4. COMMON OUTPUT FREQUENCY EXAMPLES**

Output Frequency (MHz)	Input Frequency (MHz)	S1, S0
66.66	20	M, H
72	12	H, L
75	25	H, M
80	10	H, H
83.33	25	M, H
90	15	H, L
100	20	L, H
120	15	H, H
125	25	L, H
133.3	25	L, M
150	25	H, L

# NB3N511

**Table 4. ATTRIBUTES**

Characteristics		Value
ESD Protection	Human Body Model Machine Model Charged Device Model	> 1 kV > 150 V > 1 kV
RPU – OE Input Pull-up Resistor		270 kΩ
Moisture Sensitivity (Note 1)	SOIC-8	Level 1
Flammability Rating	Oxygen Index: 28 to 34	UL 94 V 0 @ 0.125 in
Transistor Count		9555
Meets or exceeds JEDEC Spec EIA/JESD78 IC Latchup Test		

1. For additional information, see Application Note AND8003/D.

**Table 5. MAXIMUM RATINGS**

Symbol	Parameter	Condition 1	Condition 2	Rating	Unit
V <sub>DD</sub>	Positive Power Supply	GND = 0 V		7	V
V <sub>IO</sub>	Input and Output Voltages			-0.5 V ≤ V <sub>IO</sub> ≤ V <sub>DD</sub> + 0.5	V
T <sub>A</sub>	Operating Temperature Range			-40 to +85	°C
T <sub>stg</sub>	Storage Temperature Range			-65 to +150	°C
θ <sub>JA</sub>	Thermal Resistance (Junction-to-Ambient)	0 lfpm 500 lfpm	SOIC-8 SOIC-8	190 130	°C/W
θ <sub>JC</sub>	Thermal Resistance (Junction-to-Case)	(Note 2)	SOIC-8	41 to 44	°C/W
T <sub>sol</sub>	Wave Solder Pb-Free			265	°C

Stresses exceeding those listed in the Maximum Ratings table may damage the device. If any of these limits are exceeded, device functionality should not be assumed, damage may occur and reliability may be affected.

2. JEDEC standard multilayer board – 2S2P (2 signal, 2 power) with 8 filled thermal vias under exposed pad.

# NB3N511

**Table 6. DC CHARACTERISTICS**  $V_{DD} = 3.3\text{ V} \pm 10\%$  or  $5.0\text{ V} \pm 5\%$  unless otherwise noted,  $GND = 0\text{ V}$ ,  $T_A = -40^\circ\text{C}$  to  $+85^\circ\text{C}$

Symbol	Characteristic	Min	Typ	Max	Unit
$V_{DD}$	Operating Voltage $V_{DD} = 5\text{ V}$ $V_{DD} = 3.3\text{ V}$	4.75 3.0		5.25 3.6	V
$I_{DD}$	Power Supply Current – Inputs and outputs open, CLKOUT operating at 100 MHz (with 20 MHz crystal) $V_{DD} = 5\text{ V}$ $V_{DD} = 3.3\text{ V}$		9 8		mA
$V_{OH}$	Output HIGH Voltage $I_{OH} = -4\text{ mA}$ CMOS High	$V_{DD} - 0.4$			V
$V_{OH}$	Output HIGH Voltage $I_{OH} = -25\text{ mA}$ TTL High	2.4			V
$V_{OL}$	Output LOW Voltage $I_{OL} = 25\text{ mA}$			0.4	V
$V_{IH}$	Input HIGH Voltage, ICLK only (pin 1) $V_{DD} = 5\text{ V}$ $V_{DD} = 3.3\text{ V}$	$(V_{DD}/2) + 1$ $(V_{DD}/2) + 0.7$			V
$V_{IL}$	Input LOW Voltage, ICLK only (pin 1) $V_{DD} = 5\text{ V}$ $V_{DD} = 3.3\text{ V}$			$(V_{DD}/2) - 1$ $(V_{DD}/2) - 0.7$	V
$V_{IH}$	Input HIGH Voltage, S0, S1	$V_{DD} - 0.5$			V
$V_{IL}$	Input LOW Voltage, S0, S1			0.5	V
$V_{IH}$	Input HIGH Voltage, OE (pin 7)	2.0			V
$V_{IL}$	Input LOW Voltage, OE (pin 7)			0.8	V
$C_{in}$	Input Capacitance, S0, S1 and OE		4		pF
$I_{SC}$	Output Short Circuit Current, CLKOUT		$\pm 70$		mA
	Nominal Output Impedance		20		$\Omega$

**Table 7. AC CHARACTERISTICS**  $V_{DD} = 3.3\text{ V} \pm 10\%$  or  $5.0\text{ V} \pm 5\%$  unless otherwise noted,  $GND = 0\text{ V}$ ,  $T_A = -40^\circ\text{C}$  to  $+85^\circ\text{C}$

Symbol	Characteristic	Min	Typ	Max	Unit
$f_{Xtal}$	Crystal Input Frequency (Note 3)	5		32	MHz
$f_{CLKIN}$	Clock Input Frequency	1		50	MHz
$f_{OUT}$	Output Frequency Range $f_{OUTMIN} \leq f_{IN} \times \text{Multiplier} \leq f_{OUTMAX}$ $V_{DD} = 4.25\text{ to }5.25\text{ V}$ ( $5.0\text{ V} \pm 5\%$ ) $V_{DD} = 3.0\text{ to }3.6\text{ V}$ ( $3.3\text{ V} \pm 10\%$ )	4 4		200 200	MHz
DC	Output Clock Duty Cycle at 1.5 V	45	50	55	%
$OE_H$	Output enable time, OE high to output on		50		ns
$OE_L$	Output disable time, OE low to tri-state		50		ns
$t_{jitter (rms)}$	Period Jitter (rms, $1\sigma$ )		25		ps
$t_{jitter (pk-to-pk)}$	Total Period Jitter, (peak-to-peak)		$\pm 70$		ps
$t_r/t_f$	Output rise/fall time (0.8 V to 2.0 V) (measured with 15 pF load)		1	1.5	ns

3. The crystal should be fundamental mode, parallel resonant. Do not use third overtone. For exact tuning when using a crystal, capacitors should be connected from pins X1/CLK to GND and X2 to GND. The value of these capacitors is given by the following equation, where  $C_L$  is the specified crystal load capacitance: Crystal capacitance (pF) =  $(C_L - 12) \times 2$ . So, for a crystal with 16 pF load capacitance, use two 8 pF capacitors.

APPLICATIONS INFORMATION

**High Frequency CMOS/TTL Oscillators**

The NB3N511, along with a low frequency fundamental mode crystal, can build a high frequency TTL output oscillator. For example, a 20 MHz crystal connected to the NB3N511 with the 5X output selected (S1 = L, S0 = H) produces an 100 MHz CMOS/TTL output clock.

**Decoupling and External Components**

The NB3N511 requires a 0.01 μF decoupling capacitor to be connected between V<sub>DD</sub> and GND on pins 2 and 3. It must be connected close to the NB3N511 to minimize lead inductance. Control input pins can be connected to device pins V<sub>DD</sub> or GND, or to the V<sub>DD</sub> and GND planes on the board.

**Series Termination Resistor**

A 33 Ω terminating resistor can be used next to the CLK pin for trace lengths over one inch.

**Crystal Information**

The crystal used should be a fundamental mode (do not use third overtone), parallel resonant. Crystal load capacitors should be connected from pins X1 to ground and X2 to ground to optimize the frequency accuracy, See Figure 1.

The total on chip capacitance is approximately 12 pF. A parallel resonant, fundamental mode crystal should be used. The device crystal connections should include pads for

small capacitors from X1 to ground and from X2 to ground. These capacitors are used to adjust the stray capacitance of the board to match the nominally required crystal load capacitance. Because load capacitance can only be increased in this trimming process, it is important to keep stray capacitance to a minimum by using very short PCB traces (and no vias) between the crystal and device. Crystal capacitors, if needed, must be connected from each of the pins X1 and X2 to ground. The value (in pF) of these crystal caps should equal  $(C_L - 12 \text{ pF}) * 2$ . In this equation,  $C_L$  = crystal load capacitance in pF. Example: For a crystal with a 16 pF load capacitance, each crystal capacitor would be 8 pF  $[(16 - 12) * 2 = 8]$ .

**Table 8. RECOMMENDED CRYSTAL PARAMETERS**

Parameter	Value
Crystal Cut	Fundamental AT Cut
Resonance	Parallel Resonance
Load Capacitance	18 pF
Operating Range	-40 to +85°C
Shunt Capacitance	5 pF Max
Equivalent Series Resistance (ESR)	50 Ω Max
Correlation Drive Level	1.0 mW Max

**ORDERING INFORMATION**

Device	Package	Shipping†
NB3N511DG	SOIC-8 (Pb-Free)	98 Units / Rail
NB3N511DR2G	SOIC-8 (Pb-Free)	2500 / Tape & Reel

†For information on tape and reel specifications, including part orientation and tape sizes, please refer to our Tape and Reel Packaging Specifications Brochure, BRD8011/D.

# NB3N511

## PACKAGE DIMENSIONS

SOIC-8 NB  
CASE 751-07  
ISSUE AK

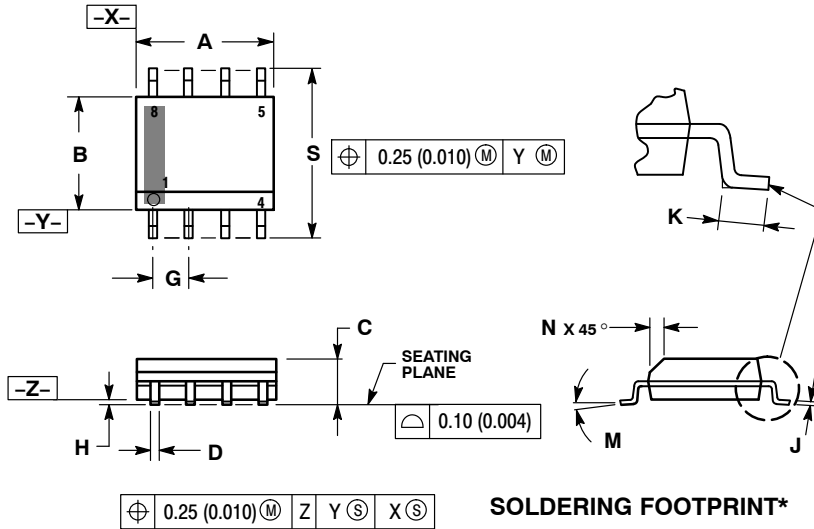

**NOTES:**

1. DIMENSIONING AND TOLERANCING PER ANSI Y14.5M, 1982.
2. CONTROLLING DIMENSION: MILLIMETER.
3. DIMENSION A AND B DO NOT INCLUDE MOLD PROTRUSION.
4. MAXIMUM MOLD PROTRUSION 0.15 (0.006) PER SIDE.
5. DIMENSION D DOES NOT INCLUDE DAMBAR PROTRUSION. ALLOWABLE DAMBAR PROTRUSION SHALL BE 0.127 (0.005) TOTAL IN EXCESS OF THE D DIMENSION AT MAXIMUM MATERIAL CONDITION.
6. 751-01 THRU 751-06 ARE OBSOLETE. NEW STANDARD IS 751-07.

DIM	MILLIMETERS		INCHES	
	MIN	MAX	MIN	MAX
A	4.80	5.00	0.189	0.197
B	3.80	4.00	0.150	0.157
C	1.35	1.75	0.053	0.069
D	0.33	0.51	0.013	0.020
G	1.27 BSC		0.050 BSC	
H	0.10	0.25	0.004	0.010
J	0.19	0.25	0.007	0.010
K	0.40	1.27	0.016	0.050
M	0°	8°	0°	8°
N	0.25	0.50	0.010	0.020
S	5.80	6.20	0.228	0.244

**SOLDERING FOOTPRINT\***

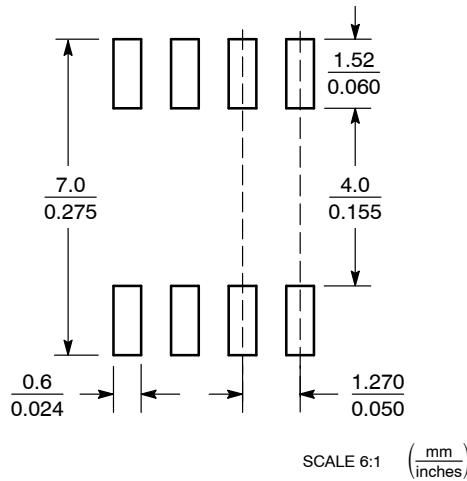

\*For additional information on our Pb-Free strategy and soldering details, please download the ON Semiconductor Soldering and Mounting Techniques Reference Manual, SOLDERRM/D.

ON Semiconductor and are trademarks of Semiconductor Components Industries, LLC dba ON Semiconductor or its subsidiaries in the United States and/or other countries. ON Semiconductor owns the rights to a number of patents, trademarks, copyrights, trade secrets, and other intellectual property. A listing of ON Semiconductor's product/patent coverage may be accessed at [www.onsemi.com/site/pdf/Patent-Marking.pdf](http://www.onsemi.com/site/pdf/Patent-Marking.pdf). ON Semiconductor reserves the right to make changes without further notice to any products herein. ON Semiconductor makes no warranty, representation or guarantee regarding the suitability of its products for any particular purpose, nor does ON Semiconductor assume any liability arising out of the application or use of any product or circuit, and specifically disclaims any and all liability, including without limitation special, consequential or incidental damages. Buyer is responsible for its products and applications using ON Semiconductor products, including compliance with all laws, regulations and safety requirements or standards, regardless of any support or applications information provided by ON Semiconductor. "Typical" parameters which may be provided in ON Semiconductor data sheets and/or specifications can and do vary in different applications and actual performance may vary over time. All operating parameters, including "Typicals" must be validated for each customer application by customer's technical experts. ON Semiconductor does not convey any license under its patent rights nor the rights of others. ON Semiconductor products are not designed, intended, or authorized for use as a critical component in life support systems or any FDA Class 3 medical devices or medical devices with a same or similar classification in a foreign jurisdiction or any devices intended for implantation in the human body. Should Buyer purchase or use ON Semiconductor products for any such unintended or unauthorized application, Buyer shall indemnify and hold ON Semiconductor and its officers, employees, subsidiaries, affiliates, and distributors harmless against all claims, costs, damages, and expenses, and reasonable attorney fees arising out of, directly or indirectly, any claim of personal injury or death associated with such unintended or unauthorized use, even if such claim alleges that ON Semiconductor was negligent regarding the design or manufacture of the part. ON Semiconductor is an Equal Opportunity/Affirmative Action Employer. This literature is subject to all applicable copyright laws and is not for resale in any manner.

**PUBLICATION ORDERING INFORMATION**

**LITERATURE FULFILLMENT:**  
Literature Distribution Center for ON Semiconductor  
19521 E. 32nd Pkwy, Aurora, Colorado 80011 USA  
**Phone:** 303-675-2175 or 800-344-3860 Toll Free USA/Canada  
**Fax:** 303-675-2176 or 800-344-3867 Toll Free USA/Canada  
**Email:** [orderlit@onsemi.com](mailto:orderlit@onsemi.com)

**N. American Technical Support:** 800-282-9855 Toll Free  
USA/Canada  
**Europe, Middle East and Africa Technical Support:**  
Phone: 421 33 790 2910

**ON Semiconductor Website:** [www.onsemi.com](http://www.onsemi.com)  
**Order Literature:** <http://www.onsemi.com/orderlit>

For additional information, please contact your local Sales Representative

## Looking for pricing, stock, or lifecycle information?

Click below to explore more details on WIN SOURCE:

- ⊖ [View NB3N511DR2G on WIN SOURCE](#)
- ⊖ [ON Semiconductor Information](#)

## Optimize Your Supply Chain with WIN SOURCE Solutions

- ✓ Global Sourcing Solution
- ✓ Obsolete Management
- ✓ Cost Control Management
- ✓ Shortage Management
- ✓ Alternative Solution
- ✓ Excess Inventory Management