



**THE DATASHEET OF  
NB3N3020DTG**



# 3.3 V, LVPECL/LVCMOS Clock Multiplier

## NB3N3020

### Description

The NB3N3020 is a high precision, low phase noise selectable clock multiplier. The device takes a 5 – 27 MHz fundamental mode parallel resonant crystal or a 2 – 210 MHz LVCMOS single ended clock source and generates a differential LVPECL output and a single ended LVCMOS/LVTTL output at a selectable clock output frequency which is a multiple of the input clock frequency. Three tri-level (Low, Mid, High) LVCMOS/LVTTL single ended select pins set one of 26 possible clock multipliers. The LVCMOS/LVTTL output enable (OE1) tri-states the LVCMOS/LVTTL clock output (CLK1) when low. When the LVTTL/LVCMOS output enable (OE2) is LOW, LVPECL CLK2 is forced LOW and LVPECL  $\overline{\text{CLK2}}$  is forced HIGH.

This device is housed in 5 mm x 4.4 mm narrow body TSSOP 16 pin package.

### Features

- Selectable Clock Multiplier
- External Loop Filter is Not Required
- LVPECL Differential Output
- LVCMOS/ LVTTL Outputs
- RMS Period Jitter of 5 ps
- Jitter or Low Phase Noise at 125 MHz [25 MHz Input]:
 

Offset	Noise Power
100 Hz	-95 dBc/Hz
1 kHz	-107 dBc/Hz
10 kHz	-112 dBc/Hz
100 kHz	-117 dBc/Hz
1 MHz	-117 dBc/Hz
10 MHz	-134 dBc/Hz
- Operating Range 3.3 V  $\pm 10\%$
- Industrial Temperature Range -40°C to +85°C
- These are Pb-Free Devices

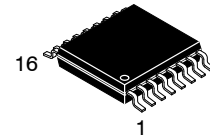

TSSOP-16  
DT SUFFIX  
CASE 948F

### MARKING DIAGRAM

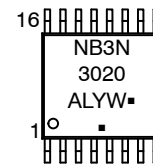

- A = Assembly Location
- L = Wafer Lot
- Y = Year
- W = Work Week
- = Pb-Free Package

(Note: Microdot may be in either location)

### PIN CONFIGURATION

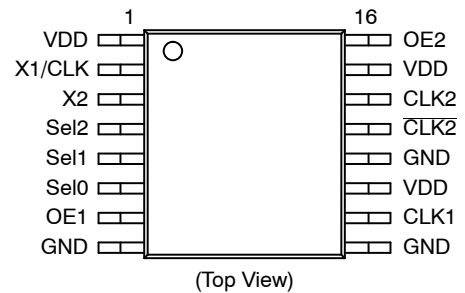

### ORDERING INFORMATION

See detailed ordering and shipping information in the package dimensions section on page 7 of this data sheet.

# NB3N3020

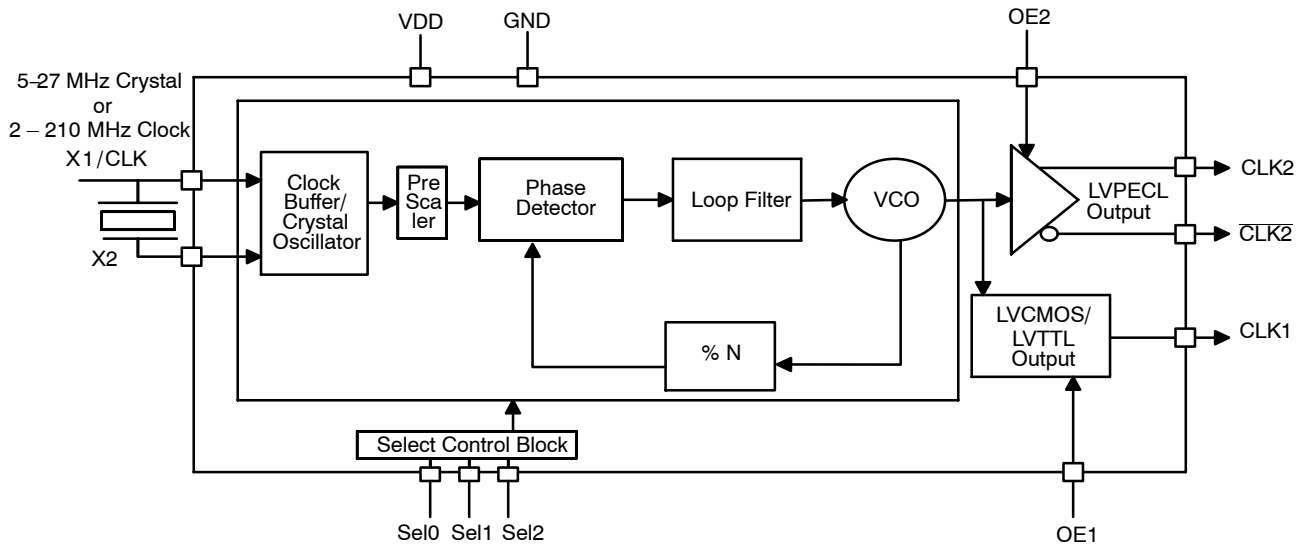

Figure 1. NB3N3020 Simplified Logic Diagram

Table 1. PIN DESCRIPTION

Pin	Name	I/O	Description
6	Sel0	Tri-Level Input	Frequency select input 0. When left open, defaults to V <sub>DD</sub> /2. See output select Table 2 for details.
5	Sel1	Tri-Level Input	Frequency select input 1. When left open, defaults to V <sub>DD</sub> /2. See output select Table 2 for details.
4	Sel2	Tri-Level Input	Frequency select input 2. When left open, defaults to V <sub>DD</sub> /2. See output select Table 2 for details.
1, 11, 15	V <sub>DD</sub>	Power Supply	Positive supply voltage pins are connected to +3.3 V supply voltage.
2	X1/CLK	Input	Crystal or Clock input. Connect to 5 – 27 MHz crystal source or 2 – 210 MHz single-ended clock. See Table 2.
3	X2	Input	Crystal input. Connect to a 5 – 27 MHz crystal or leave unconnected for clock input. See Table 2.
7	OE1	LVTTL/LVCMOS Input	Output enable input that synchronously tri-states CLK1 output when low. Internal pull-up resistor to V <sub>DD</sub> .
16	OE2	LVTTL/LVCMOS Input	Output enable input that when LOW synchronously controls LVPECL outputs by forcing CLK2 LOW and CLK2 HIGH. Internal pull-up resistor to V <sub>DD</sub> .
8, 9, 12	GND	Power Supply	Ground 0 V. These pins provide GND return path for the devices.
13	CLK2	LVPECL Output	Inverted clock output. Clock frequency equals input frequency times multiplier.
14	CLK2	LVPECL Output	Non-inverted clock output. Clock frequency equals input frequency times multiplier.
10	CLK1	LVTTL/LVCMOS Output	Clock Output. Clock frequency equals input frequency times multiplier.

# NB3N3020

**Table 2. OUTPUT FREQUENCY CLOCK MULTIPLIER SELECT TABLE**

Sel2	Sel1	Sel0	CLK1, CLK2, CLK2	Clock Input Range [MHz]	Crystal Input Range [MHz]
L	L	L	Low (Power Down)	–	–
L	L	M	Input X 1	25 – 210	25 – 27
L	L	H	Input X 4/3 (or 1 1/3)	15 – 157.5	15 – 27
L	M	L	Input X 1.5	10 – 140	10 – 27
L	M	M	1.6	25 – 131.25	25 – 27
L	M	H	Input X 1.875	40 – 112	–
L	H	L	Input X 2	25 – 105	25 – 27
L	H	M	Input X 7/3 (or 2 1/3)	15 – 90	15 – 27
L	H	H	Input X 2.4	25 – 87.5	25 – 27
M	L	L	Input X 2.5	10 – 84	10 – 27
M	L	M	Input X 8/3 (or 2 2/3)	15 – 78.75	15 – 27
M	L	H	Input X 3	15 – 70	15 – 27
M	M	L	Input X 3.125	40 – 67.20	–
M	M	M	Input X 3.2	25 – 65.63	25 – 27
M	M	H	Input X 10/3 (or 3 1/3)	15 – 63	15 – 27
M	H	L	Input X 3.75	20 – 56	20 – 27
M	H	M	Input X 4	2 – 52.5	5 – 25
M	H	H	Input X 5	6 – 42	6 – 27
H	L	L	Input X 6	5 – 35	5 – 27
H	L	M	Input X 6.25	20 – 33.6	20 – 27
H	L	H	Input X 19/3 (or 6 1/3)	15 – 33.16	15 – 27
H	M	L	Input X 8	5 – 26.25	5 – 26.25
H	M	M	Input X 25/3 (or 8 1/3)	15 – 25.2	15 – 25.2
H	M	H	Input X 10	5 – 21	5 – 21
H	H	L	Input X 12	5 – 17.5	5 – 17.5
H	H	M	Input X 12.5	10 – 16.8	10 – 16.8
H	H	H	Input X 16	5 – 13.125	5 – 13.125

L – Low, M – Mid, H – High

## Recommended Crystal Parameters

Crystal	Fundamental AT-Cut
Frequency	5 – 27 MHz
Load Capacitance	16 – 20 pF
Shunt Capacitance, C0	7 pF Max
Equivalent Series Resistance	35 Ω Max
Initial Accuracy at 25°C	±20 ppm
Temperature Stability	±30 ppm
Aging	±20 ppm
C0/C1 Ration	250 Max

## Device Operation

The NB3N3020 is a Clock multiplier. The device can take crystal or clock input and generates LVPECL and LVCMOS/ LVTTTL clock outputs which are multiples of the

input as determined by the tri-level select inputs [Sel0, Sel1, Sel2].

## Clock Multiplication

NB3N3020 is a clock multiplier with the clock multiplier selected by the tri level select inputs [Sel0, Sel1, Sel2]. NB3N3020 has a LVTTTL/LVCMOS output [CLK1] and a LVPECL clock output [CLK2, CLK2].

## Output Enable

The device has an output enable [OE] which is used to tri-state the outputs. OE1 controls the CLK1 clock output where as OE2 controls the CLK2, CLK2 clock outputs. When OE1 or OE2 are disabled, the respective clock output(s) are tri-stated. In this mode of operation, PLL is still running, with the respective clock outputs tri-stated. When the OE1 or OE2 are enabled, the clock outputs

become active synchronous to the internal PLL output clock and do not create any glitches or runt pulses during the transition. In power down mode, the outputs are tri-stated regardless of the state of the OE1, OE2.

The device has an output enable [OE1] which accepts LVTTTL/LVCMOS levels and when set LOW will disable the LVTTTL/LVCMOS level CLK1 to tri-state. Output enable OE2 accepts LVTTTL/LVCMOS levels to disable the LVPECL level outputs by forcing CLK2 LOW and CLK2b HIGH. When OE1 or OE2 are set LOW (Disabled), the PLL remains running while the respective clock outputs are disabled. When the OE1 or OE2 are set enabled (HIGH), the clock outputs become active synchronous to the internal PLL output clock and will not create any glitches or runt pulses during the transition. Both OE1 and OE2 inputs have pull-up resistors which default to VDD when floated open. In power down mode, the outputs are tri-stated (zero current) regardless of the state of the OE1, OE2.

### Changing Clock Multiplier

The clock output frequency can be dynamically changed using Sel0, Sel1, Sel2 pins. When the clock frequency is changed, the clock outputs move from one frequency to another and the PLL locks to the new frequency within a settling time of 3 msec. There is no glitch during this transition when the clock outputs are active {not tri-stated by OE1, OE2}.

### Crystal/ Clock Input

The device takes in a 5 – 27 MHz crystal input or 2 – 210 MHz clock input. Once powered up, the input frequency is fixed and should not be changed dynamically. The input cannot accept a spread spectrum clock and needs a fixed frequency clock for device operation. The input frequencies for clock and crystal input for specific multipliers are determined by Table 3.

### Power Up

When the NB3N3020 is powered up, it takes 10 msec for the PLL's to stabilize and lock to the desired frequency of operation as selected by Sel0, Sel1, Sel2. During this time period, there may be glitches in the clock outputs.

### Power Down:

The device can be powered down when the Sel0, Sel1, Sel2 pins are all connected to GND. In this mode of operation, PLL is turned off and the device consumes less than 5 mA of current. There may be a glitch in clock outputs when the device is powering down. In power down mode, the outputs are tri-stated regardless of the state of the OE1, OE2.

In the cases where the application requires glitch-less transitions, in order to avoid glitches it is recommended to use synchronous OE signaling to mask glitches to the clock outputs.

# NB3N3020

**Table 3. ATTRIBUTES**

Characteristics	Value
ESD Protection Human Body Model	2 kV
Moisture Sensitivity, Indefinite Time Out of Dry pack (Note 1)	Level 1
Flammability Rating Oxygen Index: 28 to 34	UL 94 V-0 @ 0.125 in
Transistor Count	8287 Devices
Meets or exceeds JEDEC Spec EIA/JESD78 IC Latchup Test	

1. For additional information, see Application Note AND8003/D.

**Table 4. MAXIMUM RATINGS** (Note 2)

Symbol	Parameter	Condition 1	Condition 2	Rating	Unit
V <sub>DD</sub>	Positive Power Supply	GND = 0 V		4.6	V
V <sub>I</sub>	Input Voltage (VIN)	GND = 0 V	GND ≤ V <sub>I</sub> ≤ V <sub>DD</sub>	-0.5 V to V <sub>DD</sub> + 0.5 V	V
I <sub>out</sub>	LVPECL Output Current	Continuous Surge		25 50	mA
T <sub>A</sub>	Operating Temperature Range			-40 to +85	°C
T <sub>stg</sub>	Storage Temperature Range			-65 to +150	°C
θ <sub>JA</sub>	Thermal Resistance (Junction-to-Ambient)	0 lfpm 500 lfpm	TSSOP-16 TSSOP-16	138 108	°C/W
θ <sub>JC</sub>	Thermal Resistance (Junction-to-Case)	(Note 3)	TSSOP-16	33 to 36	°C/W
T <sub>sol</sub>	Wave Solder			265	°C

Stresses exceeding those listed in the Maximum Ratings table may damage the device. If any of these limits are exceeded, device functionality should not be assumed, damage may occur and reliability may be affected.

- Maximum ratings applied to the device are individual stress limit values (not normal operating conditions) and not valid simultaneously. If stress limits are exceeded device functional operation is not implied, damage may occur and reliability may be affected.
- JEDEC standard multilayer board – 2S2P (2 signal, 2 power).

**Table 5. DC CHARACTERISTICS** (V<sub>DD</sub> = 3.3 V ±10%, GND = 0 V, T<sub>A</sub> = -40°C to +85°C)

Symbol	Characteristic	Min	Typ	Max	Unit
V <sub>DD</sub>	Power Supply Voltage	2.97	3.3	3.63	V
I <sub>DD</sub>	Power Supply Current (Note 4)		60	75	mA
I <sub>DDOE</sub>	Power Supply Current when OE1, OE2 is Set Low		50		mA
I <sub>DDOFF</sub>	Power Supply Current when PLL is powered off by Sel0, Sel1, Sel2			5	mA
V <sub>IH</sub>	Input HIGH Voltage (X1/CLK, OE1, OE2)	2000		V <sub>DD</sub> + 300	mV
V <sub>IL</sub>	Input LOW Voltage (X1/CLK, OE1, OE2)	GND - 300		800	mV
V <sub>IH</sub>	Input HIGH Voltage (Sel0, Sel1, Sel2)	0.72 V <sub>DD</sub>		V <sub>DD</sub> + 300	mV
V <sub>IL</sub>	Input LOW Voltage (Sel0, Sel1, Sel2)	GND - 300		800	mV
V <sub>IM</sub>	Input Mid Voltage (Sel0, Sel1, Sel2) (When left open, defaults to V <sub>DD</sub> /2)		V <sub>DD</sub> /2		mV
V <sub>OH</sub>	Output HIGH Voltage for CLK2, CLK2 (See Figure 3)	V <sub>DD</sub> - 1.145		V <sub>DD</sub> - 0.895	V
V <sub>OL</sub>	Output LOW Voltage for CLK2, CLK2 (See Figure 3)	V <sub>DD</sub> - 2.090		V <sub>DD</sub> - 1.600	V
V <sub>OH</sub>	Output HIGH Voltage for CLK1 [I <sub>OH</sub> = -12 mA]	2.4			V
V <sub>OL</sub>	Output LOW Voltage for CLK1 [I <sub>OL</sub> = 12 mA]			0.4	V

NOTE: Device will meet the specifications after thermal equilibrium has been established when mounted in a test socket or printed circuit board with maintained transverse airflow greater than 500 lfpm.

- Measurement taken at FCLK<sub>out</sub> = 125 MHz with LVPECL and LVCMOS/ LVTTTL outputs not terminated.

# NB3N3020

**Table 6. AC CHARACTERISTICS** ( $V_{DD} = 3.3\text{ V} \pm 10\%$ ,  $GND = 0\text{ V}$ ,  $T_A = -40^\circ\text{C}$  to  $+85^\circ\text{C}$ ) (Note 5)

Symbol	Characteristic	Min	Typ	Max	Unit
$f_{CLKIN}$	Crystal Input Frequency	5.0		27	MHz
$f_{CLKIN}$	Clock Input Frequency	2.0		210	MHz
$f_{CLKOUT}$	Output Clock Frequency			210	MHz
$\Phi_{NOISE}$	Phase-Noise Performance ( $f_{CLKout} = 125\text{ MHz}$ , 25 MHz input)				
	@ 100 Hz offset from carrier		-95		dBc/Hz
	@ 1 kHz offset from carrier		-107		dBc/Hz
	@ 10 kHz offset from carrier		-112		dBc/Hz
	@ 100 kHz offset from carrier		-117		dBc/Hz
	@ 1 MHz offset from carrier		-117		dBc/Hz
	@ 10 MHz offset from carrier		-134		dBc/Hz
Tjitter p-p	Cycle-to-Cycle Jitter peak to peak (Note 6) $f_{CLKout} = 100\text{ MHz}$ and 125 MHz, 25 MHz input		20	36	ps
Tjitter rms	Cycle-to-Cycle Jitter rms (Note 7) $f_{CLKout} = 100\text{ MHz}$ and 125 MHz, 25 MHz input		5.0	9.0	ps
Tjitter p-p	Period Jitter peak to peak (Note 7) $f_{CLKout} = 100\text{ MHz}$ and 125 MHz, 25 MHz input		15	20	ps
Tjitter rms	Period Jitter rms (Note 7) $f_{CLKout} = 100\text{ MHz}$ and 125 MHz, 25 MHz input		3.0	5.0	ps
	Start up time from power up		10		ms
OE	Output Enable/Disable Time		10		us
	PLL settling time		3		ms
$t_{DUTY\_CYCLE}$	Output Clock Duty Cycle (Measured at cross point for LV PECL clock output and $V_{DD}/2$ for LVCMOS/ LVTTTL clock output)	45	50	55	%
$t_R$	Output Rise Time (Note 5) (Measured from 20% to 80%. Figure 2) LV PECL Output		340	700	ps
$t_F$	Output Fall Time (Note 5) (Measured from 20% to 80%. Figure 2) LV PECL Output		340	700	ps
$t_R$	Output Rise Time (Measured from 0.8 to 2 V, no load) LVCMOS/ LV TTL Output			1500	ps
$t_F$	Output Fall Time (Measured from 2.0 V to 0.8 V, no load) LVCMOS/ LV TTL Output			1500	ps
$t_R/t_F$	Input Rise time/ Fall time for LV CMOS/ LV TTL clock input [X1/CLK]	0		1500	ps

NOTE: Device will meet the specifications after thermal equilibrium has been established when mounted in a test socket or printed circuit board with maintained transverse airflow greater than 500 lfpm.

5. Measurement taken with outputs terminated with  $50\ \Omega$  to  $V_{DD} - 2\text{ V}$ . See Figure 2.

6. Sampled with 1000 cycles

7. Sampled with 10000 cycles

# NB3N3020

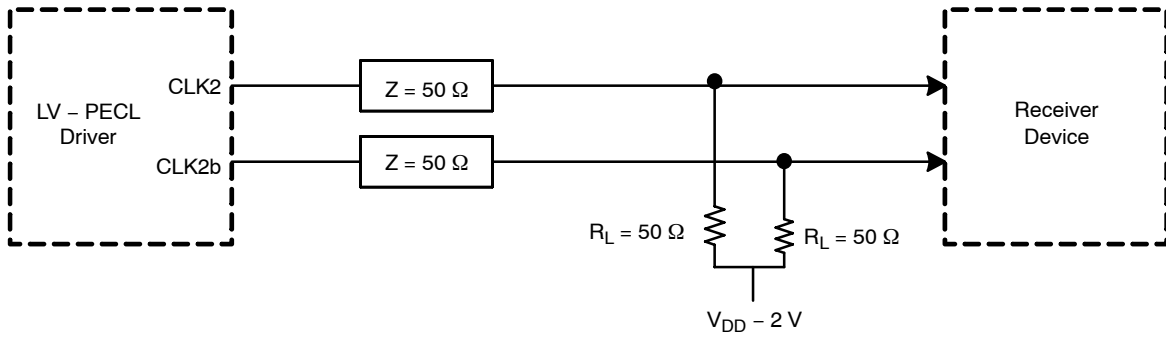

Figure 2. Typical Termination for Output Driver for Device Evaluation

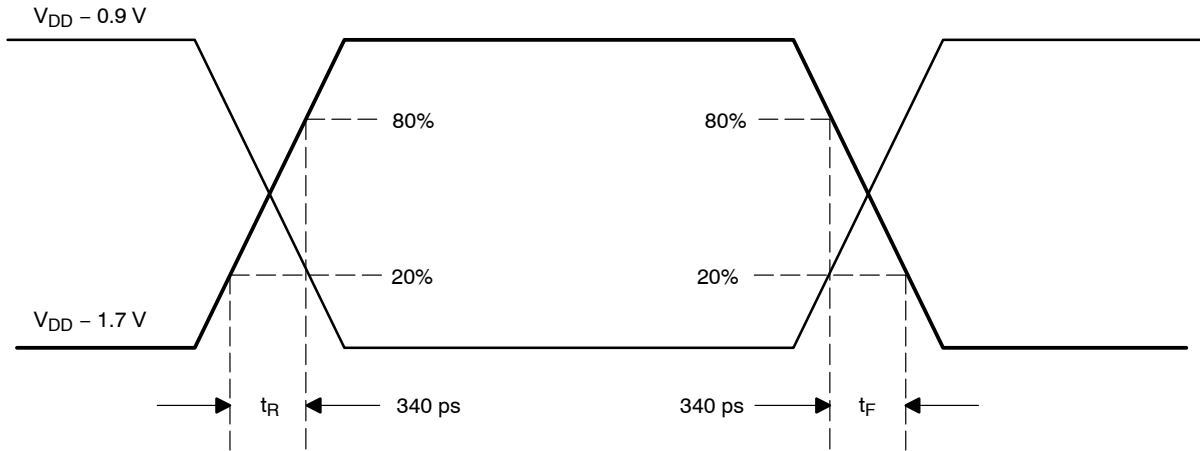

Figure 3. LV-PECL Output Parameter Characteristics

## ORDERING INFORMATION

Device	Package	Shipping <sup>†</sup>
NB3N3020DTG	TSSOP-16 (Pb-Free)	96 Units / Rail
NB3N3020DTR2G	TSSOP-16 (Pb-Free)	2500 / Tape & Reel

<sup>†</sup>For information on tape and reel specifications, including part orientation and tape sizes, please refer to our Tape and Reel Packaging Specifications Brochure, BRD8011/D.

# MECHANICAL CASE OUTLINE PACKAGE DIMENSIONS

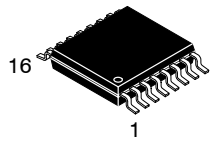

**TSSOP-16 WB**  
CASE 948F  
ISSUE B

DATE 19 OCT 2006

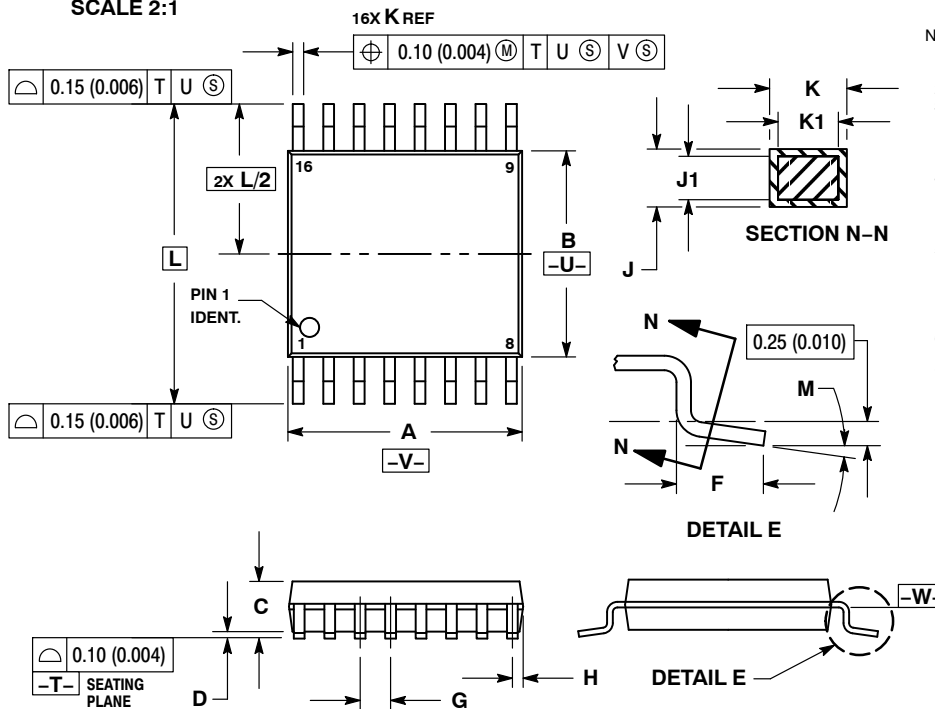

**NOTES:**

1. DIMENSIONING AND TOLERANCING PER ANSI Y14.5M, 1982.
2. CONTROLLING DIMENSION: MILLIMETER.
3. DIMENSION A DOES NOT INCLUDE MOLD FLASH, PROTRUSIONS OR GATE BURRS. MOLD FLASH OR GATE BURRS SHALL NOT EXCEED 0.15 (0.006) PER SIDE.
4. DIMENSION B DOES NOT INCLUDE INTERLEAD FLASH OR PROTRUSION. INTERLEAD FLASH OR PROTRUSION SHALL NOT EXCEED 0.25 (0.010) PER SIDE.
5. DIMENSION K DOES NOT INCLUDE DAMBAR PROTRUSION. ALLOWABLE DAMBAR PROTRUSION SHALL BE 0.08 (0.003) TOTAL IN EXCESS OF THE K DIMENSION AT MAXIMUM MATERIAL CONDITION.
6. TERMINAL NUMBERS ARE SHOWN FOR REFERENCE ONLY.
7. DIMENSION A AND B ARE TO BE DETERMINED AT DATUM PLANE -W-.

DIM	MILLIMETERS		INCHES	
	MIN	MAX	MIN	MAX
A	4.90	5.10	0.193	0.200
B	4.30	4.50	0.169	0.177
C	---	1.20	---	0.047
D	0.05	0.15	0.002	0.006
F	0.50	0.75	0.020	0.030
G	0.65 BSC		0.026 BSC	
H	0.18	0.28	0.007	0.011
J	0.09	0.20	0.004	0.008
J1	0.09	0.16	0.004	0.006
K	0.19	0.30	0.007	0.012
K1	0.19	0.25	0.007	0.010
L	6.40 BSC		0.252 BSC	
M	0°	8°	0°	8°

**RECOMMENDED  
SOLDERING FOOTPRINT\***

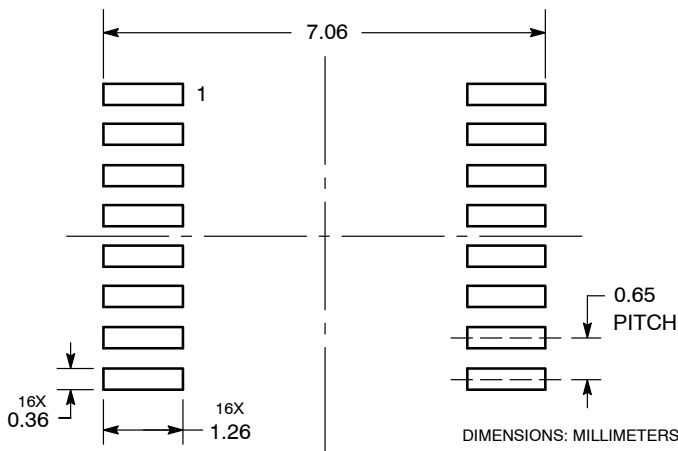

**GENERIC  
MARKING DIAGRAM\***

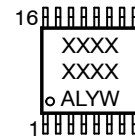

- XXXX = Specific Device Code
- A = Assembly Location
- L = Wafer Lot
- Y = Year
- W = Work Week
- G or ■ = Pb-Free Package

\*This information is generic. Please refer to device data sheet for actual part marking. Pb-Free indicator, "G" or microdot "■", may or may not be present. Some products may not follow the Generic Marking.

\*For additional information on our Pb-Free strategy and soldering details, please download the **onsemi** Soldering and Mounting Techniques Reference Manual, SOLDERRM/D.

<b>DOCUMENT NUMBER:</b>	<b>98ASH70247A</b>	Electronic versions are uncontrolled except when accessed directly from the Document Repository. Printed versions are uncontrolled except when stamped "CONTROLLED COPY" in red.
<b>DESCRIPTION:</b>	<b>TSSOP-16</b>	<b>PAGE 1 OF 1</b>

**onsemi** and **ONSEMI** are trademarks of Semiconductor Components Industries, LLC dba **onsemi** or its subsidiaries in the United States and/or other countries. **onsemi** reserves the right to make changes without further notice to any products herein. **onsemi** makes no warranty, representation or guarantee regarding the suitability of its products for any particular purpose, nor does **onsemi** assume any liability arising out of the application or use of any product or circuit, and specifically disclaims any and all liability, including without limitation special, consequential or incidental damages. **onsemi** does not convey any license under its patent rights nor the rights of others.

**onsemi**, **Onsemi**, and other names, marks, and brands are registered and/or common law trademarks of Semiconductor Components Industries, LLC dba "**onsemi**" or its affiliates and/or subsidiaries in the United States and/or other countries. **onsemi** owns the rights to a number of patents, trademarks, copyrights, trade secrets, and other intellectual property. A listing of **onsemi**'s product/patent coverage may be accessed at [www.onsemi.com/site/pdf/Patent-Marking.pdf](http://www.onsemi.com/site/pdf/Patent-Marking.pdf). **onsemi** reserves the right to make changes at any time to any products or information herein, without notice. The information herein is provided "as-is" and **onsemi** makes no warranty, representation or guarantee regarding the accuracy of the information, product features, availability, functionality, or suitability of its products for any particular purpose, nor does **onsemi** assume any liability arising out of the application or use of any product or circuit, and specifically disclaims any and all liability, including without limitation special, consequential or incidental damages. Buyer is responsible for its products and applications using **onsemi** products, including compliance with all laws, regulations and safety requirements or standards, regardless of any support or applications information provided by **onsemi**. "Typical" parameters which may be provided in **onsemi** data sheets and/or specifications can and do vary in different applications and actual performance may vary over time. All operating parameters, including "Typicals" must be validated for each customer application by customer's technical experts. **onsemi** does not convey any license under any of its intellectual property rights nor the rights of others. **onsemi** products are not designed, intended, or authorized for use as a critical component in life support systems or any FDA Class 3 medical devices or medical devices with a same or similar classification in a foreign jurisdiction or any devices intended for implantation in the human body. Should Buyer purchase or use **onsemi** products for any such unintended or unauthorized application, Buyer shall indemnify and hold **onsemi** and its officers, employees, subsidiaries, affiliates, and distributors harmless against all claims, costs, damages, and expenses, and reasonable attorney fees arising out of, directly or indirectly, any claim of personal injury or death associated with such unintended or unauthorized use, even if such claim alleges that **onsemi** was negligent regarding the design or manufacture of the part. **onsemi** is an Equal Opportunity/Affirmative Action Employer. This literature is subject to all applicable copyright laws and is not for resale in any manner.

## ADDITIONAL INFORMATION

### TECHNICAL PUBLICATIONS:

Technical Library: [www.onsemi.com/design/resources/technical-documentation](http://www.onsemi.com/design/resources/technical-documentation)  
onsemi Website: [www.onsemi.com](http://www.onsemi.com)

### ONLINE SUPPORT: [www.onsemi.com/support](http://www.onsemi.com/support)

For additional information, please contact your local Sales Representative at [www.onsemi.com/support/sales](http://www.onsemi.com/support/sales)

## Looking for pricing, stock, or lifecycle information?

Click below to explore more details on WIN SOURCE:

 [View NB3N3020DTG on WIN SOURCE](#)

 [ON Semiconductor](#) Information

## Optimize Your Supply Chain with WIN SOURCE Solutions

-  Global Sourcing Solution
-  Obsolete Management
-  Cost Control Management
-  Shortage Management
-  Alternative Solution
-  Excess Inventory Management