



**THE DATASHEET OF
N74F827D,623**



DATA SHEET

74F827

10-bit buffer/line driver, non-inverting
(3-State)

Product data

2004 Jan 21

Replaces Product specification 74F827/74F828 of 1994 Dec 5

10-bit buffer/line driver, non-inverting (3-State)

74F827

FEATURES

- High impedance NPN base inputs for reduced loading (20 μ A in HIGH and LOW states)
- I_{IL} is 20 μ A vs FAST family spec of 600 μ A
- Ideal where high speed, light bus loading and increased fan-in are required
- Controlled rise and fall times to minimize ground bounce
- Glitch free power-up in 3-State
- Flow through pinout architecture for microprocessor oriented applications
- Outputs sink 64 mA
- 74F827 is available in SSOP type II package

DESCRIPTION

The 74F827 10-Bit buffer provides high performance bus interface buffering for wide data/address paths or buses carrying parity. The device has NOR Output Enables ($\overline{OE}0$, $\overline{OE}1$) for maximum control flexibility.

TYPE	TYPICAL PROPAGATION DELAY	TYPICAL SUPPLY CURRENT (TOTAL)
74F827	6.0ns	60 mA

ORDERING INFORMATION

COMMERCIAL RANGE: $V_{CC} = 5 V \pm 10\%$; $T_{amb} = 0^\circ C$ to $+70^\circ C$

Type number	Package		Version
	Name	Description	
N74F827N	DIP24	plastic dual in-line package; 24 leads (300 mil)	SOT222-1
N74F827D	SO24	plastic small outline package; 24 leads; body width 7.5 mm	SOT137-1
N74F827DB	SSOP24	plastic shrink small outline package; 24 leads; body width 5.3 mm	SOT340-1

INPUT AND OUTPUT LOADING AND FAN-OUT TABLE

PINS	DESCRIPTION	74F(U.L.) HIGH/LOW	LOAD VALUE HIGH / LOW
D0-D9	Data inputs	1.0/0.033	20 μ A / 20 μ A
$\overline{OE}0$ - $\overline{OE}1$	Output enable inputs (active-LOW)	1.0/0.033	20 μ A / 20 μ A
Q0-Q9	Data outputs	1200/106.7	24 mA / 64 mA

NOTES:

One (1.0) FAST Unit Load is defined as: 20 μ A in the HIGH state and 0.6 mA in the LOW state.

PIN CONFIGURATION

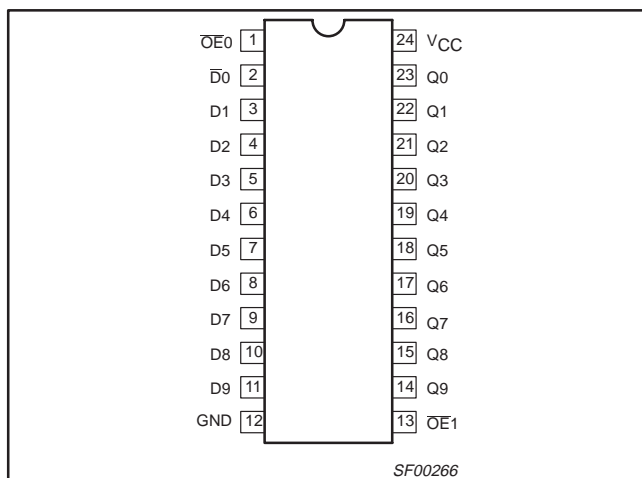

10-bit buffer/line driver, non-inverting (3-State)

74F827

LOGIC SYMBOL

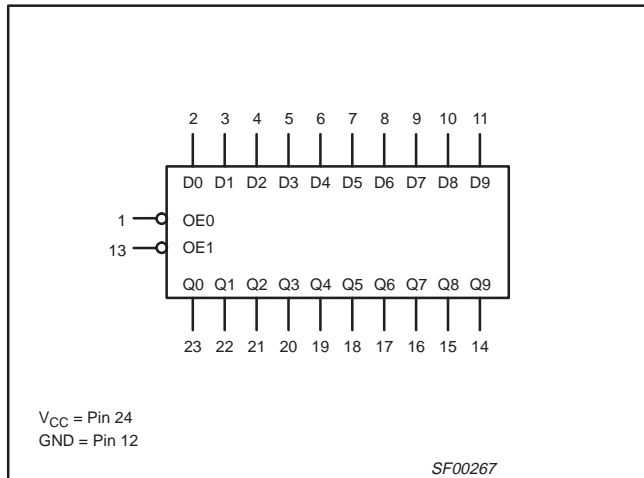

LOGIC SYMBOL (IEEE/IEC)

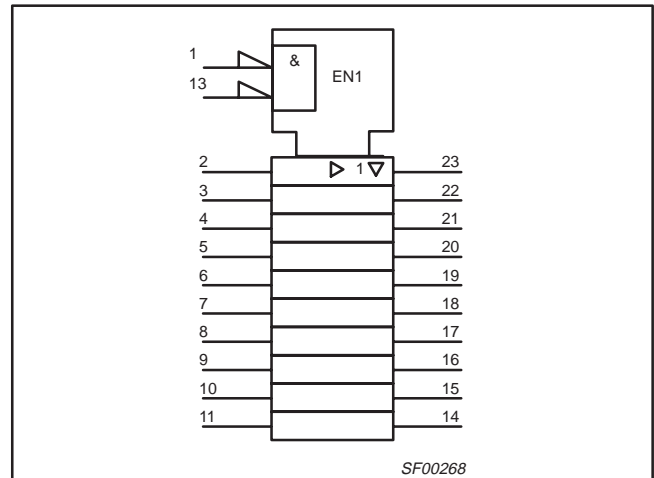

LOGIC DIAGRAM

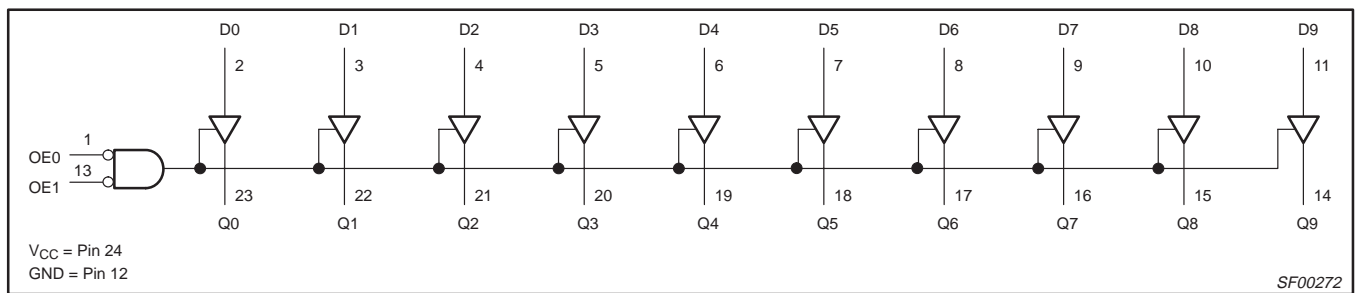

FUNCTION TABLE

INPUTS		OUTPUTS	OPERATING MODE
OE _n	D _n	Q _n	
L	L	L	Transparent
L	H	H	Transparent
H	X	Z	High impedance

- H = HIGH voltage level
- L = LOW voltage level
- X = Don't care
- Z = High impedance "off" state

10-bit buffer/line driver, non-inverting (3-State)

74F827

ABSOLUTE MAXIMUM RATINGS

Operation beyond the limits set forth in this table may impair the useful life of the device.
Unless otherwise noted these limits are over the operating free-air temperature range.

SYMBOL	PARAMETER	RATING	UNIT
V_{CC}	Supply voltage	-0.5 to +7.0	V
V_{IN}	Input voltage	-0.5 to +7.0	V
I_{IN}	Input current	-30 to +5	mA
V_{OUT}	Voltage applied to output in HIGH output state	-0.5 to $+V_{CC}$	V
I_{OUT}	Current applied to output in LOW output state	128	mA
T_{amb}	Operating free-air temperature range	0 to +70	°C
T_{stg}	Storage temperature range	-65 to +150	°C

RECOMMENDED OPERATING CONDITIONS

SYMBOL	PARAMETER	LIMITS			UNIT
		Min	Nom	Max	
V_{CC}	Supply voltage	4.5	5.0	5.5	V
V_{IH}	HIGH-level input voltage	2.0	-	-	V
V_{IL}	LOW-level input voltage	-	-	0.8	V
I_{IK}	Input clamp current	-	-	-18	mA
I_{OH}	HIGH-level output current	-	-	-24	mA
I_{OL}	LOW-level output current	-	-	64	mA
T_{amb}	Operating free-air temperature range	0	-	+70	°C

10-bit buffer/line driver, non-inverting (3-State)

74F827

DC ELECTRICAL CHARACTERISTICS

Over recommended operating free-air temperature range unless otherwise noted.

SYMBOL	PARAMETER	TEST CONDITIONS ¹			LIMITS			UNIT	
					MIN	TYP ²	MAX		
V _{OH}	HIGH-level output voltage	V _{CC} = MIN, V _{IL} = MAX, V _{IH} = MIN	I _{OH} = -15 mA	± 10% V _{CC}	2.4	-	-	V	
				± 5% V _{CC}	2.4	3.3	-	V	
		V _{CC} = MIN, V _{IL} = MAX, V _{IH} = MIN	I _{OH} = -24 mA	± 10% V _{CC}	2.0	-	-	V	
				± 5% V _{CC}	2.0	-	-	V	
V _{OL}	LOW-level output voltage	V _{CC} = MIN, V _{IL} = MAX, V _{IH} = MIN	I _{OL} = 64 mA	± 10% V _{CC}	-	-	0.55	V	
				± 5% V _{CC}	-	0.42	0.55	V	
V _{IK}	Input clamp voltage	V _{CC} = MIN; I _I = I _{IK}			-	-0.73	-1.2	V	
I _I	Input current at maximum input voltage	V _{CC} = 0 V; V _I = 7.0 V			-	-	100	μA	
I _{IH}	HIGH-level input current	V _{CC} = MAX; V _I = 2.7 V			-	-	20	μA	
I _{IL}	LOW-level input current	V _{CC} = MAX; V _I = 0.5 V			-	-	-20	μA	
I _{OZH}	Off-state output current, HIGH voltage applied	V _{CC} = MAX; V _O = 2.7 V			-	-	50	μA	
I _{OZL}	Off-state output current, LOW voltage applied	V _{CC} = MAX; V _O = 0.5 V			-	-	-50	μA	
I _{OS}	Short circuit output current ³	V _{CC} = MAX			-100	-	-225	mA	
I _{CC}	Supply current (total)	I _{CCH}	V _{CC} = MAX			-	50	70	mA
		I _{CCL}				-	70	100	mA
		I _{CCZ}				-	60	90	mA

NOTES:

- For conditions shown as MIN or MAX, use the appropriate value specified under operating conditions for the applicable type.
- All typical values are at V_{CC} = 5 V, T_{amb} = 25 °C.
- Not more than one output should be shorted at one time. For testing I_{OS}, the use of high-speed test apparatus and/or sample-and-hold techniques are preferable in order to minimize internal heating and more accurately reflect operational values. Otherwise, prolonged shorting of a HIGH output may raise the chip temperature well above normal and thereby cause invalid readings in other parameter tests. In any sequence of parameter tests, I_{OS} tests should be performed last.

10-bit buffer/line driver, non-inverting (3-State)

74F827

AC CHARACTERISTICS

SYMBOL	PARAMETER	CONDITIONS	LIMITS					UNIT
			T _{amb} = +25 °C V _{CC} = 5 V C _L = 50 pF; R _L = 500 Ω			T _{amb} = 0 °C to +70 °C V _{CC} = 5 V ± 10% C _L = 50 pF; R _L = 500 Ω		
			Min	Typ	Max	Min	Max	
t _{PLH} t _{PHL}	Propagation delay D _n to Q _n	Waveform 1	2.0 2.0	5.5 4.5	8.5 8.5	2.0 2.0	9.0 9.0	ns
t _{PZH} t _{PZL}	Output enable time OE _n to Q _n	Waveform 2 Waveform 3	5.0 4.0	8.0 6.0	12.0 10.5	4.5 4.0	14.0 11.5	ns
t _{PHZ} t _{PLZ}	Output disable time OE _n to Q _n	Waveform 2 Waveform 3	2.5 2.5	5.0 5.0	8.0 8.0	2.0 2.0	8.5 8.5	ns

AC CHARACTERISTICS

For 1 Output switching with C_L = 300 pF and R_L = 500 Ω load

SYMBOL	PARAMETER	CONDITIONS	LIMITS					UNIT
			T _{amb} = +25 °C V _{CC} = 5 V C _L = 300 pF; R _L = 500 Ω			T _{amb} = 0 °C to +70 °C V _{CC} = 5 V ± 10% C _L = 300 pF; R _L = 500 Ω		
			MIN	Typ	Max	MIN	Max	
t _{PLH} t _{PHL}	Propagation delay D _n to Q _n	Waveform 1	– –	9.5 7.5	13.0 10.0	– –	14.0 11.0	ns
t _{PZH} t _{PZL}	Output enable time OE _n to Q _n	Waveform 2 Waveform 3	– –	15.0 9.5	20.0 13.0	– –	21.0 14.0	ns
t _{PHZ} t _{PLZ}	Output disable time OE _n to Q _n	Waveform 2 Waveform 3	– –	15.0 9.5	19.0 13.5	– –	20.0 14.0	ns

AC CHARACTERISTICS

For 10 Outputs switching with C_L = 300 pF and R_L = 500 Ω load

SYMBOL	PARAMETER	CONDITIONS	LIMITS					UNIT
			T _{amb} = +25 °C V _{CC} = 5 V C _L = 300 pF; R _L = 500 Ω			T _{amb} = 0 °C to +70 °C V _{CC} = 5 V ± 10% C _L = 300 pF; R _L = 500 Ω		
			MIN	Typ	Max	MIN	Max	
t _{PLH} t _{PHL}	Propagation delay D _n to Q _n	Waveform 1	– –	12.0 14.0	16.0 17.0	– –	17.0 18.0	ns
t _{PZH} t _{PZL}	Output enable time OE _n to Q _n	Waveform 2 Waveform 3	– –	15.0 17.0	20.0 21.0	– –	21.0 21.5	ns
t _{PHZ} t _{PLZ}	Output disable time OE _n to Q _n	Waveform 2 Waveform 3	– –	15.0 12.5	19.0 15.5	– –	20.0 16.0	ns

10-bit buffer/line driver, non-inverting (3-State)

74F827

AC WAVEFORMS

For all waveforms, $V_M = 1.5\text{ V}$

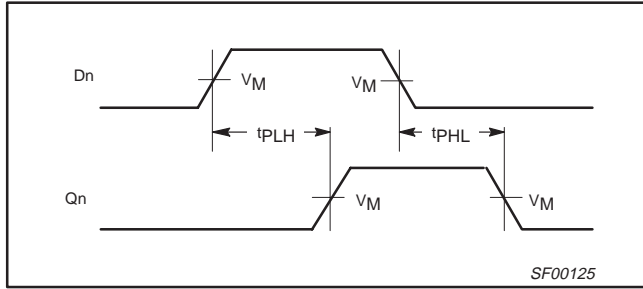

Waveform 1. Propagation delay for non-inverting output

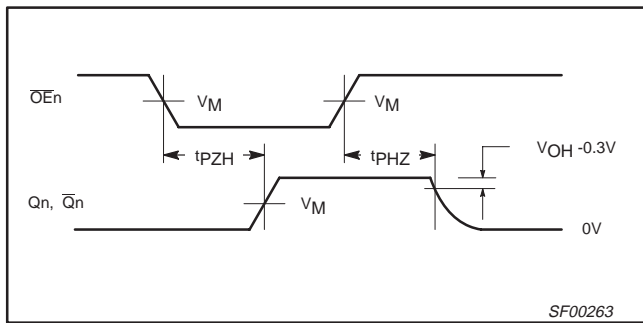

Waveform 2. 3-State Output Enable time to HIGH level and Output Disable time from HIGH level

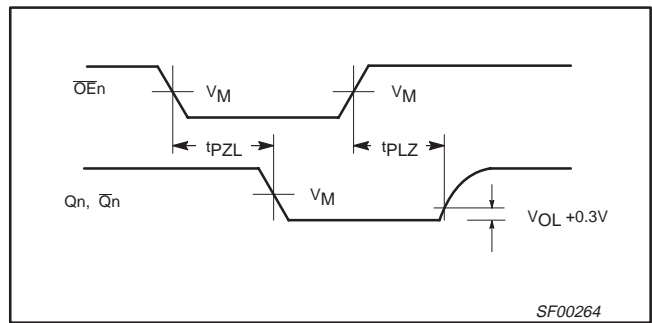

Waveform 3. 3-State Output Enable time to LOW level and Output Disable time from LOW level

Test Circuit for Open Collector Outputs

SWITCH POSITION

TEST	SWITCH
t_{PLZ}	closed
t_{PZL}	closed
All other	open

DEFINITIONS:
 R_L = Load resistor; see AC electrical characteristics for value.
 C_L = Load capacitance includes jig and probe capacitance; see AC electrical characteristics for value.
 R_T = Termination resistance should be equal to Z_{OUT} of pulse generators.

Input Pulse Definition

family	INPUT PULSE REQUIREMENTS					
	amplitude	V_M	rep. rate	t_w	t_{TLH}	t_{THL}
74F	3.0 V	1.5 V	1 MHz	500 ns	2.5 ns	2.5 ns

SF00128

10-bit buffer/line driver, non-inverting (3-State)

74F827

DIP24: plastic dual in-line package; 24 leads (300 mil)

SOT222-1

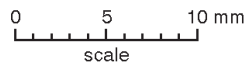
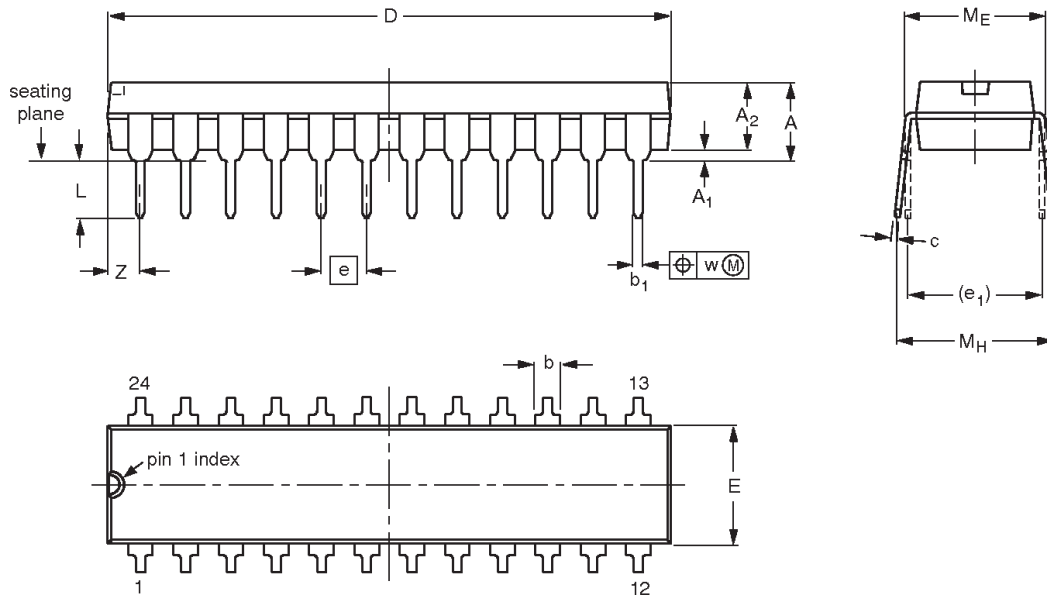

DIMENSIONS (mm dimensions are derived from the original inch dimensions)

UNIT	A max.	A ₁ min.	A ₂ max.	b	b ₁	c	D ⁽¹⁾	E ⁽¹⁾	e	e ₁	L	M _E	M _H	w	Z ⁽¹⁾ max.
mm	4.7	0.38	3.94	1.63 1.14	0.56 0.43	0.36 0.25	31.9 31.5	6.73 6.25	2.54	7.62	3.51 3.05	8.13 7.62	10.03 7.62	0.25	2.05
inches	0.185	0.015	0.155	0.064 0.045	0.022 0.017	0.014 0.010	1.256 1.240	0.265 0.246	0.1	0.3	0.138 0.120	0.32 0.30	0.395 0.300	0.01	0.081

Note

1. Plastic or metal protrusions of 0.25 mm (0.01 inch) maximum per side are not included.

OUTLINE VERSION	REFERENCES				EUROPEAN PROJECTION	ISSUE DATE
	IEC	JEDEC	JEITA			
SOT222-1		MS-001				99-12-27 03-03-12

10-bit buffer/line driver, non-inverting (3-State)

74F827

SO24: plastic small outline package; 24 leads; body width 7.5 mm

SOT137-1

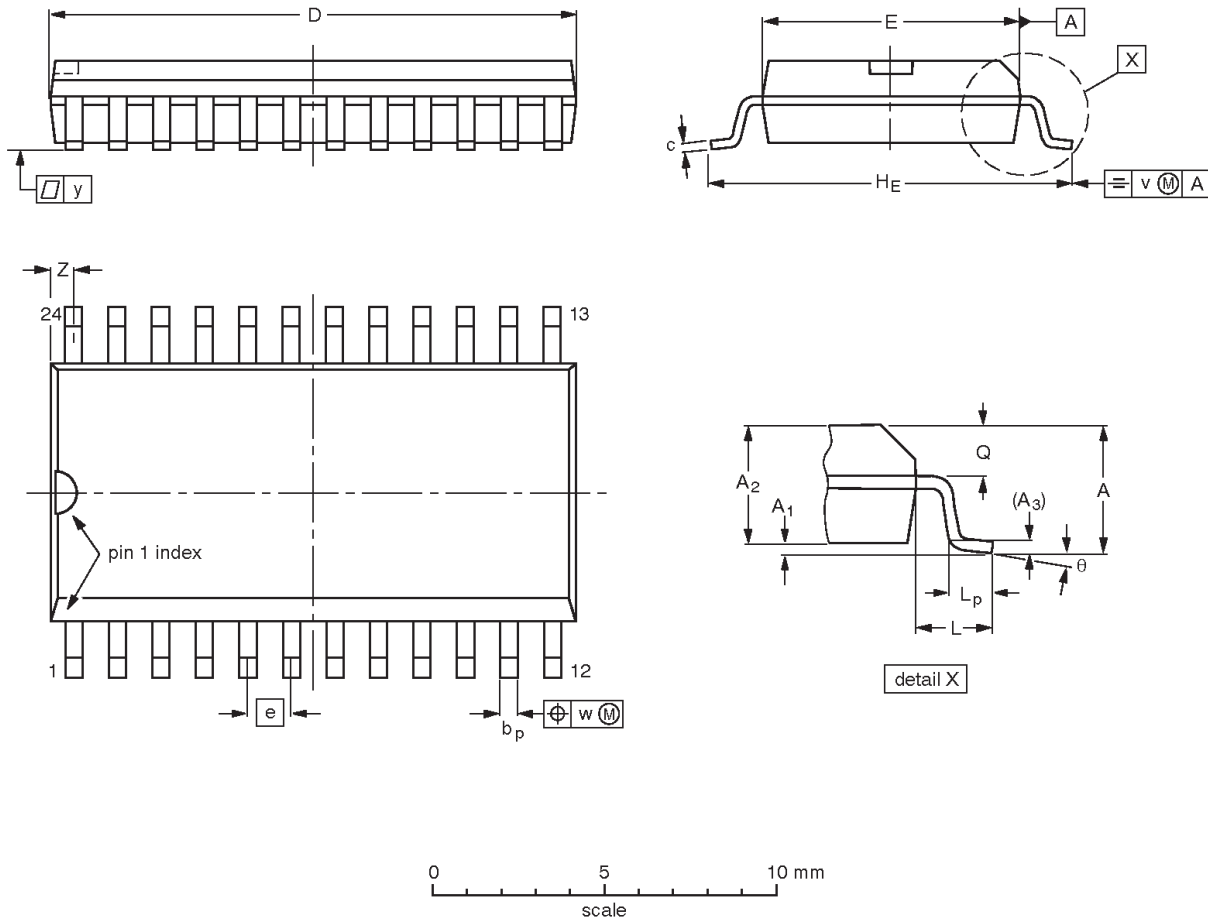

DIMENSIONS (inch dimensions are derived from the original mm dimensions)

UNIT	A max.	A ₁	A ₂	A ₃	b _p	c	D ⁽¹⁾	E ⁽¹⁾	e	H _E	L	L _p	Q	v	w	y	Z ⁽¹⁾	θ
mm	2.65	0.3 0.1	2.45 2.25	0.25	0.49 0.36	0.32 0.23	15.6 15.2	7.6 7.4	1.27	10.65 10.00	1.4	1.1 0.4	1.1 1.0	0.25	0.25	0.1	0.9 0.4	8° 0°
inches	0.1	0.012 0.004	0.096 0.089	0.01	0.019 0.014	0.013 0.009	0.61 0.60	0.30 0.29	0.05	0.419 0.394	0.055	0.043 0.016	0.043 0.039	0.01	0.01	0.004	0.035 0.016	

Note

1. Plastic or metal protrusions of 0.15 mm (0.006 inch) maximum per side are not included.

OUTLINE VERSION	REFERENCES				EUROPEAN PROJECTION	ISSUE DATE
	IEC	JEDEC	JEITA			
SOT137-1	075E05	MS-013				-99-12-27 03-02-19

10-bit buffer/line driver, non-inverting (3-State)

74F827

SSOP24: plastic shrink small outline package; 24 leads; body width 5.3 mm

SOT340-1

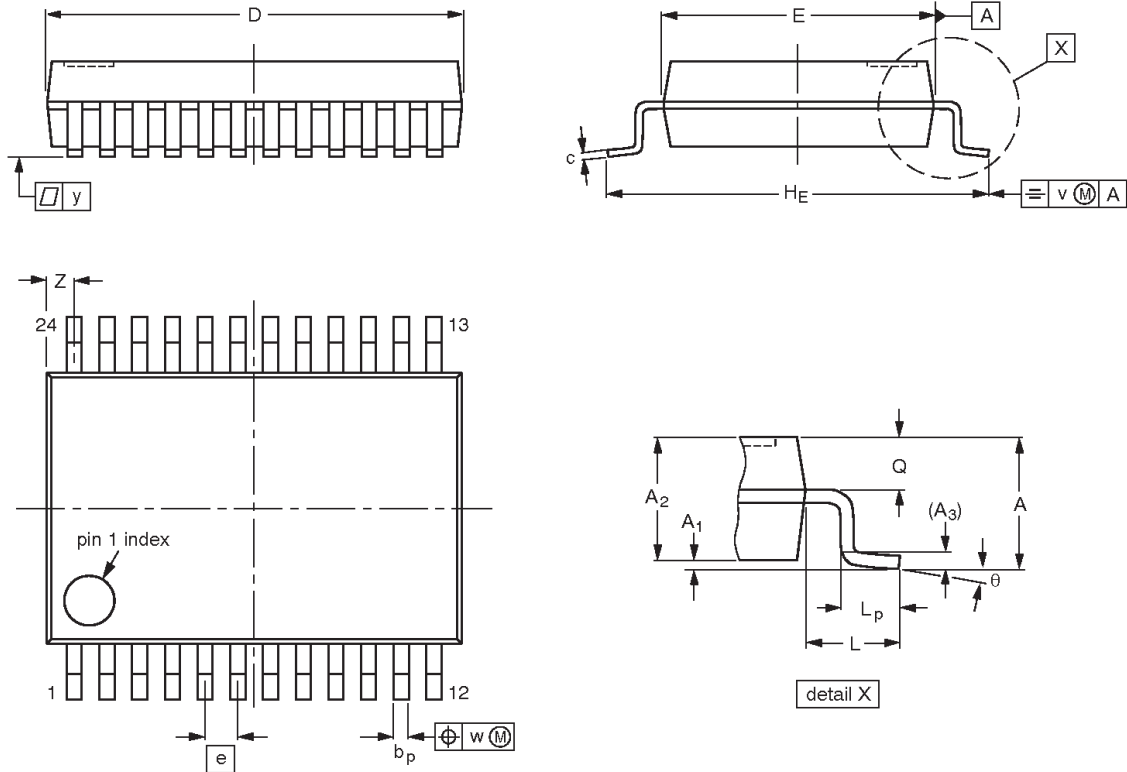

DIMENSIONS (mm are the original dimensions)

UNIT	A max.	A ₁	A ₂	A ₃	b _p	c	D ⁽¹⁾	E ⁽¹⁾	e	HE	L	L _p	Q	v	w	y	Z ⁽¹⁾	θ
mm	2	0.21 0.05	1.80 1.65	0.25	0.38 0.25	0.20 0.09	8.4 8.0	5.4 5.2	0.65	7.9 7.6	1.25	1.03 0.63	0.9 0.7	0.2	0.13	0.1	0.8 0.4	8° 0°

Note

1. Plastic or metal protrusions of 0.2 mm maximum per side are not included.

OUTLINE VERSION	REFERENCES				EUROPEAN PROJECTION	ISSUE DATE
	IEC	JEDEC	JEITA			
SOT340-1		MO-150				99-12-27 03-02-19

10-bit buffer/line driver, non-inverting (3-State)

74F827

REVISION HISTORY

Rev	Date	Description
_3	20040121	Product data (9397 750 12741). ECN 853-0880 A15336 of 21 January 2004. Replaces 74F827_74F828_2 dated 1994 Dec 5. Modifications: <ul style="list-style-type: none"> • Delete all references to 74F828 (product discontinued). • AC Characteristics table (for 10 outputs switching): change Limits columns' headings from $C_L = 50$ pF to $C_L = 300$ pF.
_2	19941205	Product specification. ECN 853-0880 14382 of 05 December 1994.

Data sheet status

Level	Data sheet status ^[1]	Product status ^{[2] [3]}	Definitions
I	Objective data	Development	This data sheet contains data from the objective specification for product development. Philips Semiconductors reserves the right to change the specification in any manner without notice.
II	Preliminary data	Qualification	This data sheet contains data from the preliminary specification. Supplementary data will be published at a later date. Philips Semiconductors reserves the right to change the specification without notice, in order to improve the design and supply the best possible product.
III	Product data	Production	This data sheet contains data from the product specification. Philips Semiconductors reserves the right to make changes at any time in order to improve the design, manufacturing and supply. Relevant changes will be communicated via a Customer Product/Process Change Notification (CPCN).

[1] Please consult the most recently issued data sheet before initiating or completing a design.

[2] The product status of the device(s) described in this data sheet may have changed since this data sheet was published. The latest information is available on the Internet at URL <http://www.semiconductors.philips.com>.

[3] For data sheets describing multiple type numbers, the highest-level product status determines the data sheet status.

Definitions

Short-form specification — The data in a short-form specification is extracted from a full data sheet with the same type number and title. For detailed information see the relevant data sheet or data handbook.

Limiting values definition — Limiting values given are in accordance with the Absolute Maximum Rating System (IEC 60134). Stress above one or more of the limiting values may cause permanent damage to the device. These are stress ratings only and operation of the device at these or at any other conditions above those given in the Characteristics sections of the specification is not implied. Exposure to limiting values for extended periods may affect device reliability.

Application information — Applications that are described herein for any of these products are for illustrative purposes only. Philips Semiconductors make no representation or warranty that such applications will be suitable for the specified use without further testing or modification.

Disclaimers

Life support — These products are not designed for use in life support appliances, devices, or systems where malfunction of these products can reasonably be expected to result in personal injury. Philips Semiconductors customers using or selling these products for use in such applications do so at their own risk and agree to fully indemnify Philips Semiconductors for any damages resulting from such application.

Right to make changes — Philips Semiconductors reserves the right to make changes in the products—including circuits, standard cells, and/or software—described or contained herein in order to improve design and/or performance. When the product is in full production (status 'Production'), relevant changes will be communicated via a Customer Product/Process Change Notification (CPCN). Philips Semiconductors assumes no responsibility or liability for the use of any of these products, conveys no license or title under any patent, copyright, or mask work right to these products, and makes no representations or warranties that these products are free from patent, copyright, or mask work right infringement, unless otherwise specified.

Contact information

For additional information please visit
<http://www.semiconductors.philips.com>. Fax: +31 40 27 24825

© Koninklijke Philips Electronics N.V. 2004
 All rights reserved. Printed in U.S.A.

Date of release: 01-04

For sales offices addresses send e-mail to:
sales.addresses@www.semiconductors.philips.com

Document order number:

9397 750 12741

Let's make things better.

Looking for pricing, stock, or lifecycle information?

Click below to explore more details on WIN SOURCE:

 [View N74F827D,623 on WIN SOURCE](#)

 [NXP / Nexperia Information](#)

Optimize Your Supply Chain with WIN SOURCE Solutions

-  Global Sourcing Solution
-  Obsolete Management
-  Cost Control Management
-  Shortage Management
-  Alternative Solution
-  Excess Inventory Management