

DATA SHEET

74F373

Octal transparent latch (3-State)

74F374

Octal D flip-flop (3-State)

Product data
Supersedes data of 1994 Dec 05

2002 Nov 20

Latch/flip-flop

74F373/74F374

74F373 Octal transparent latch (3-State)
74F374 Octal D-type flip-flop (3-State)

FEATURES

- 8-bit transparent latch — 74F373
- 8-bit positive edge triggered register — 74F374
- 3-State outputs glitch free during power-up and power-down
- Common 3-State output register
- Independent register and 3-State buffer operation
- SSOP Type II Package

DESCRIPTION

The 74F373 is an octal transparent latch coupled to eight 3-State output devices. The two sections of the device are controlled independently by enable (E) and output enable (\overline{OE}) control gates.

The data on the D inputs is transferred to the latch outputs when the enable (E) input is HIGH. The latch remains transparent to the data input while E is HIGH, and stores the data that is present one set-up time before the HIGH-to-LOW enable transition.

The 3-State output buffers are designed to drive heavily loaded 3-State buses, MOS memories, or MOS microprocessors.

The active-LOW output enable (\overline{OE}) controls all eight 3-State buffers independent of the latch operation. When \overline{OE} is LOW, latched or transparent data appears at the output.

When \overline{OE} is HIGH, the outputs are in high impedance "off" state, which means they will neither drive nor load the bus.

The 74F374 is an 8-bit edge triggered register coupled to eight 3-State output buffers. The two sections of the device are controlled independently by clock (CP) and output enable (\overline{OE}) control gates.

The register is fully edge triggered. The state of the D input, one set-up time before the LOW-to-HIGH clock transition is transferred to the corresponding flip-flop's Q output.

The 3-State output buffers are designed to drive heavily loaded 3-State buses, MOS memories, or MOS microprocessors.

The active-LOW output enable (\overline{OE}) controls all eight 3-State buffers independent of the register operation. When \overline{OE} is LOW, the data in the register appears at the outputs. When \overline{OE} is HIGH, the outputs are in high impedance "off" state, which means they will neither drive nor load the bus.

TYPE	TYPICAL PROPAGATION DELAY	TYPICAL SUPPLY CURRENT (TOTAL)
74F373	4.5 ns	35 mA

TYPE	TYPICAL f_{max}	TYPICAL SUPPLY CURRENT (TOTAL)
74F374	165 MHz	55 mA

ORDERING INFORMATION

DESCRIPTION	ORDER CODE	PKG DWG #
	COMMERCIAL RANGE $V_{CC} = 5 V \pm 10\%$, $T_{amb} = 0\text{ }^{\circ}\text{C to } +70\text{ }^{\circ}\text{C}$	
20-pin plastic DIP	N74F373N, N74F374N	SOT146-1
20-pin plastic SOL	N74F373D, N74F374D	SOT163-1
20-pin plastic SSOP type II	N74F373DB, N74F374DB	SOT339-1

INPUT AND OUTPUT LOADING AND FAN OUT TABLE

PINS	DESCRIPTION	74F (U.L.) HIGH / LOW	LOAD VALUE HIGH/LOW
D0 - D7	Data inputs	1.0 / 1.0	20 μA / 0.6 mA
E (74F373)	Enable input (active-HIGH)	1.0 / 1.0	20 μA / 0.6 mA
\overline{OE}	Output enable inputs (active-LOW)	1.0 / 1.0	20 μA / 0.6 mA
CP (74F374)	Clock pulse input (active rising edge)	1.0 / 1.0	20 μA / 0.6 mA
Q0 - Q7	3-State outputs	150 / 40	3.0 mA / 24 mA

NOTE: One (1.0) FAST unit load is defined as: 20 μA in the HIGH state and 0.6 mA in the LOW state.

Latch/flip-flop

74F373/74F374

PIN CONFIGURATION – 74F373

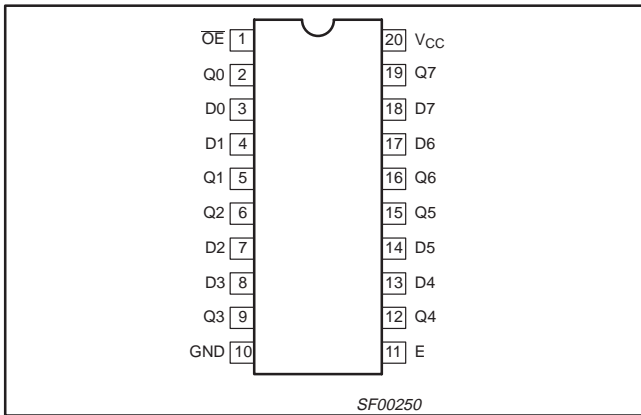

PIN CONFIGURATION – 74F374

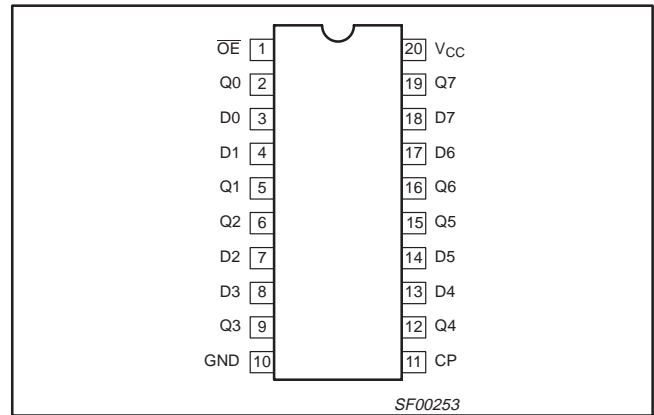

LOGIC SYMBOL – 74F373

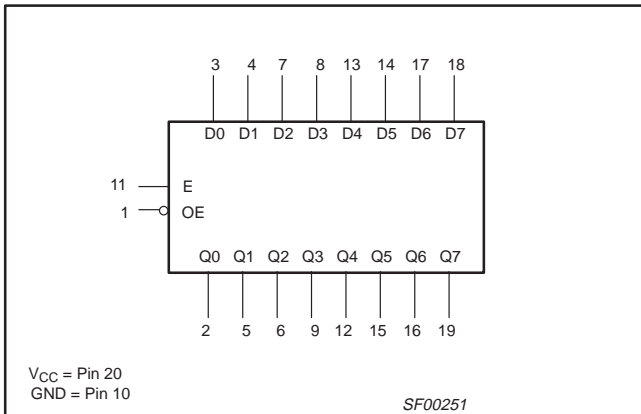

IEC/IEE SYMBOL – 74F374

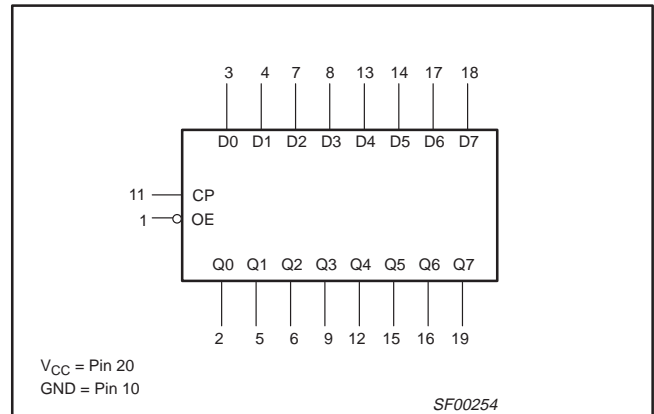

IEC/IEEE SYMBOL – 74F373

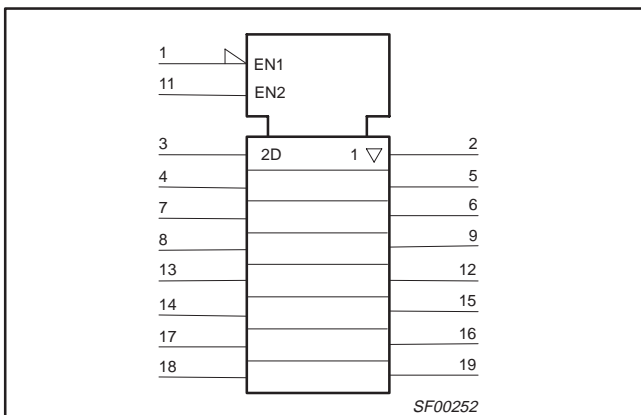

IEC/IEEE SYMBOL – 74F374

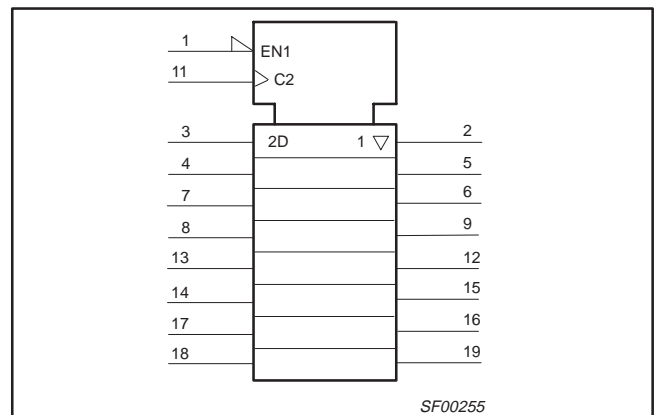

Latch/flip-flop

74F373/74F374

LOGIC DIAGRAM FOR 74F373

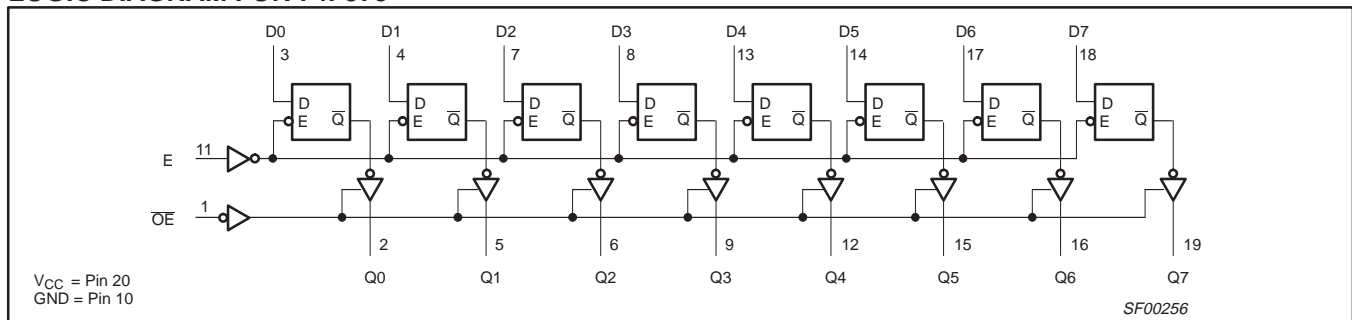

LOGIC DIAGRAM FOR 74F374

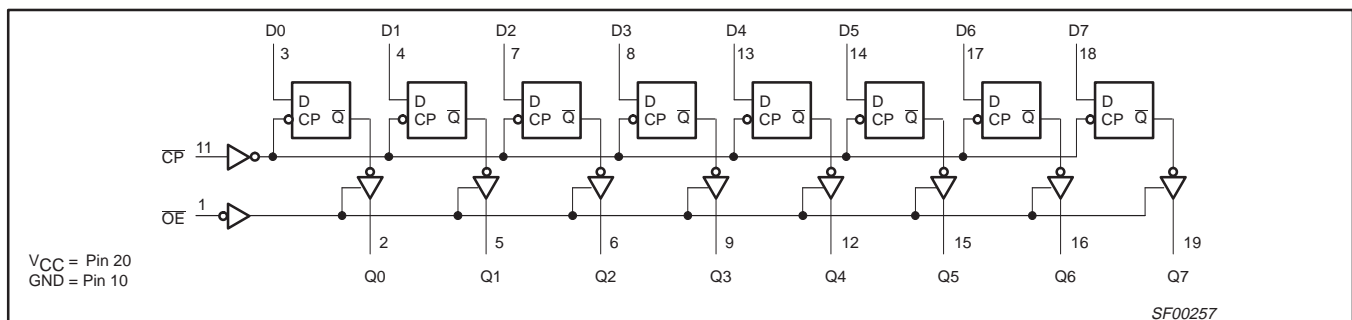

FUNCTION TABLE FOR 74F373

INPUTS			INTERNAL REGISTER	OUTPUTS	OPERATING MODE
OE	E	D _n		Q0 - Q7	
L	H	L	L	L	Enable and read register
L	H	H	H	H	
L	↓	l	L	L	Latch and read register
L	↓	h	H	H	
L	L	X	NC	NC	Hold
H	L	X	NC	Z	Disable outputs
H	H	D _n	D _n	Z	

NOTES:

- H = High-voltage level
- h = HIGH state must be present one set-up time before the HIGH-to-LOW enable transition
- L = Low-voltage level
- l = LOW state must be present one set-up time before the HIGH-to-LOW enable transition
- NC = No change
- X = Don't care
- Z = High impedance "off" state
- ↓ = HIGH-to-LOW enable transition

Latch/flip-flop

74F373/74F374

FUNCTION TABLE FOR 74F374

INPUTS			INTERNAL REGISTER	OUTPUTS	OPERATING MODE
\overline{OE}	CP	Dn		Q0 – Q7	
L	↑	l	L	L	Load and read register
L	↑	h	H	H	
L	↑	X	NC	NC	Hold
H	↑	X	NC	Z	Disable outputs
H	↑	Dn	Dn	Z	

NOTES:

- H = High-voltage level
 h = HIGH state must be present one set-up time before the LOW-to-HIGH clock transition
 L = Low-voltage level
 l = LOW state must be present one set-up time before the LOW-to-HIGH clock transition
 NC = No change
 X = Don't care
 Z = High impedance "off" state
 ↑ = LOW-to-HIGH clock transition
 ↑ = Not LOW-to-HIGH clock transition

ABSOLUTE MAXIMUM RATINGS

Operation beyond the limit set forth in this table may impair the useful life of the device. Unless otherwise noted these limits are over the operating free air temperature range.

SYMBOL	PARAMETER	RATING	UNIT
V _{CC}	Supply voltage	-0.5 to +7.0	V
V _{IN}	Input voltage	-0.5 to +7.0	V
I _{IN}	Input current	-30 to +5	mA
V _{OUT}	Voltage applied to output in HIGH output state	-0.5 to V _{CC}	V
I _{OUT}	Current applied to output in LOW output state	48	mA
T _{amb}	Operating free air temperature range	0 to +70	°C
T _{stg}	Storage temperature range	-65 to +150	°C

RECOMMENDED OPERATING CONDITIONS

SYMBOL	PARAMETER	LIMITS			UNIT
		MIN	NOM	MAX	
V _{CC}	Supply voltage	4.5	5.0	5.5	V
V _{IH}	HIGH-level input voltage	2.0	-	-	V
V _{IL}	LOW-level input voltage	-	-	0.8	V
I _{Ik}	Input clamp current	-	-	-18	mA
I _{OH}	HIGH-level output current	-	-	-3	mA
I _{OL}	LOW-level output current	-	-	24	mA
T _{amb}	Operating free air temperature range	0	-	+70	°C

Latch/flip-flop

74F373/74F374

DC ELECTRICAL CHARACTERISTICS

(Over recommended operating free-air temperature range unless otherwise noted.)

SYMBOL	PARAMETER	TEST CONDITIONS ¹	LIMITS			UNIT
			MIN	TYP ²	MAX	
V _{OH}	HIGH-level output voltage	V _{CC} = MIN, V _{IL} = MAX, V _{IH} = MIN, I _{OH} = MAX	±10%V _{CC}	2.4		V
			±5%V _{CC}	2.7	3.4	V
V _{OL}	LOW-level output voltage	V _{CC} = MIN, V _{IL} = MAX, V _{IH} = MIN, I _{OL} = MAX	±10%V _{CC}		0.35 0.50	V
			±5%V _{CC}		0.35 0.50	V
V _{IK}	Input clamp voltage	V _{CC} = MIN, I _I = I _{IK}		-0.73	-1.2	V
I _I	Input current at maximum input voltage	V _{CC} = MAX, V _I = 7.0 V			100	μA
I _{IH}	High-level input current	V _{CC} = MAX, V _I = 2.7 V			20	μA
I _{IL}	Low-level input current	V _{CC} = MAX, V _I = 0.5 V			-0.6	mA
I _{OZH}	Off-state output current, high-level voltage applied	V _{CC} = MAX, V _O = 2.7 V			50	μA
I _{OZL}	Off-state output current, low-level voltage applied	V _{CC} = MAX, V _O = 0.5 V			-50	μA
I _{OS}	Short-circuit output current ³	V _{CC} = MAX		-60	-150	mA
I _{CC}	Supply current (total)	74F373			35 60	mA
		74F374			57 86	mA

NOTES:

- For conditions shown as MIN or MAX, use the appropriate value specified under recommended operating conditions for the applicable type.
- All typical values are at V_{CC} = 5 V, T_{amb} = 25 °C.
- Not more than one output should be shorted at a time. For testing I_{OS}, the use of high-speed test apparatus and/or sample-and-hold techniques are preferable in order to minimize internal heating and more accurately reflect operational values. Otherwise, prolonged shorting of a high output may raise the chip temperature well above normal and thereby cause invalid readings in other parameter tests. In any sequence of parameter tests, I_{OS} tests should be performed last.

AC ELECTRICAL CHARACTERISTICS

SYMBOL	PARAMETER	TEST CONDITION	LIMITS					UNIT	
			T _{amb} = +25 °C V _{CC} = +5.0 V C _L = 50 pF; R _L = 500 Ω			T _{amb} = 0 °C to +70 °C V _{CC} = +5.0 V ± 10% C _L = 50 pF; R _L = 500 Ω			
			MIN	TYP	MAX	MIN	MAX		
t _{PLH} t _{PHL}	Propagation delay Dn to Qn	74F373	Waveform 3	3.0 2.0	5.3 3.7	7.0 5.0	3.0 2.0	8.0 6.0	ns
t _{PLH} t _{PHL}	Propagation delay E to Qn		Waveform 2	5.0 3.0	9.0 4.0	11.5 7.0	5.0 3.0	12.0 8.0	ns
t _{PZH} t _{PZL}	Output enable time to HIGH or LOW level		Waveform 6 Waveform 7	2.0 2.0	5.0 5.6	11.0 7.5	2.0 2.0	11.5 8.5	ns
t _{PHZ} t _{PLZ}	Output disable time from HIGH or LOW level		Waveform 6 Waveform 7	2.0 2.0	4.5 3.8	6.5 5.0	2.0 2.0	7.0 6.0	ns
f _{max}	Maximum clock frequency	74F374	Waveform 1	150	165		140		ns
t _{PLH} t _{PHL}	Propagation delay CP to Qn		Waveform 1	3.5 3.5	5.0 5.0	7.5 7.5	3.0 3.0	8.5 8.5	ns
t _{PZH} t _{PZL}	Output enable time to HIGH or LOW level		Waveform 6 Waveform 7	2.0 2.0	9.0 5.3	11.0 7.5	2.0 2.0	12.0 8.5	ns
t _{PHZ} t _{PLZ}	Output disable time from HIGH or LOW level		Waveform 6 Waveform 7	2.0 2.0	5.3 4.3	6.0 5.5	2.0 2.0	7.0 6.5	ns

Latch/flip-flop

74F373/74F374

AC SET-UP REQUIREMENTS

SYMBOL	PARAMETER	TEST CONDITION	LIMITS					UNIT	
			T _{amb} = +25 °C V _{CC} = +5.0 V C _L = 50 pF, R _L = 500 Ω			T _{amb} = 0 °C to +70 °C V _{CC} = +5.0 V ± 10% C _L = 50 pF, R _L = 500 Ω			
			MIN	TYP	MAX	MIN	MAX		
t _{su} (H) t _{su} (L)	Set-up time, HIGH or LOW level Dn to E	74F373	Waveform 4	0 1.0			0 1.0		ns
t _h (H) t _h (L)	Hold time, HIGH or LOW level Dn to E		Waveform 4	3.0 3.0			3.0 3.0		
t _w (H)	E Pulse width, HIGH		Waveform 1	3.5			4.0		
t _{su} (H) t _{su} (L)	Set-up time, HIGH or LOW level Dn to CP	74F374	Waveform 5	2.0 2.0			2.0 2.0		ns
t _h (H) t _h (L)	Hold time, HIGH or LOW level Dn to CP		Waveform 5	0 0			0 0		
t _w (H) t _w (L)	CP Pulse width, HIGH or LOW		Waveform 5	3.5 4.0			3.5 4.0		

AC WAVEFORMS

For all waveforms, V_M = 1.5 V.

The shaded areas indicate when the input is permitted to change for predictable output performance.

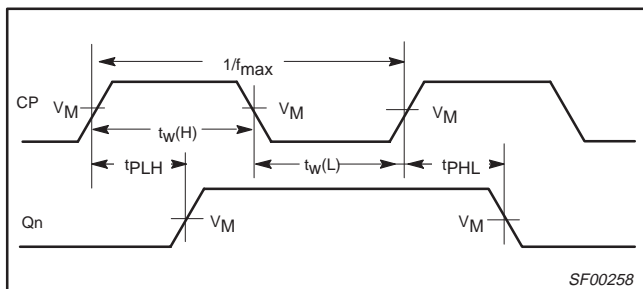

Waveform 1. Propagation delay for clock input to output, clock pulse widths, and maximum clock frequency

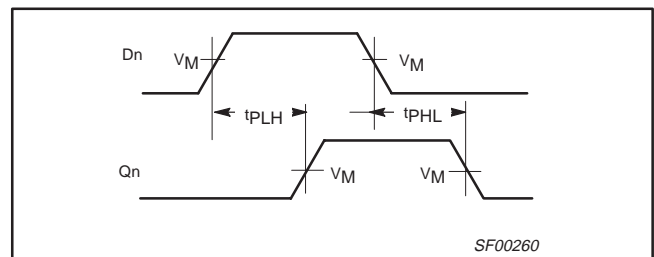

Waveform 3. Propagation delay for data to output

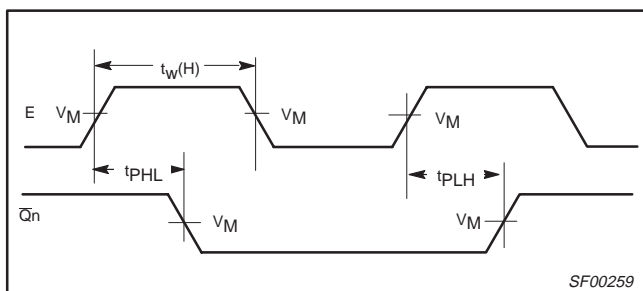

Waveform 2. Propagation delay for enable to output and enable pulse width

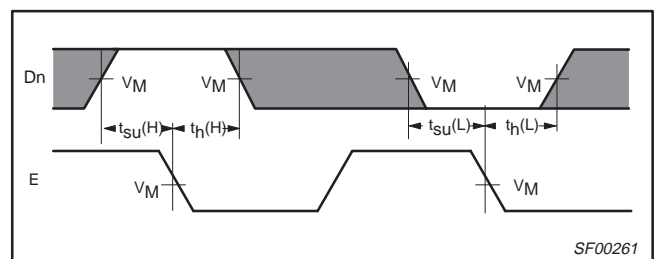

Waveform 4. Data set-up time and hold times

Latch/flip-flop

74F373/74F374

AC WAVEFORMS (continued)

For all waveforms, $V_M = 1.5\text{ V}$.

The shaded areas indicate when the input is permitted to change for predictable output performance.

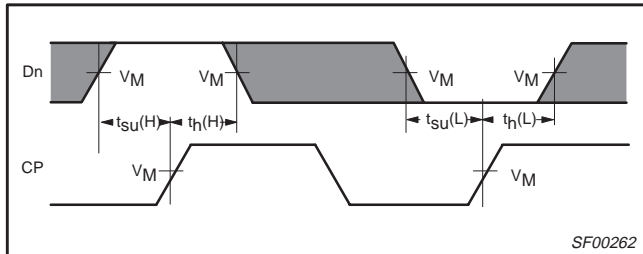

Waveform 5. Data set-up time and hold times

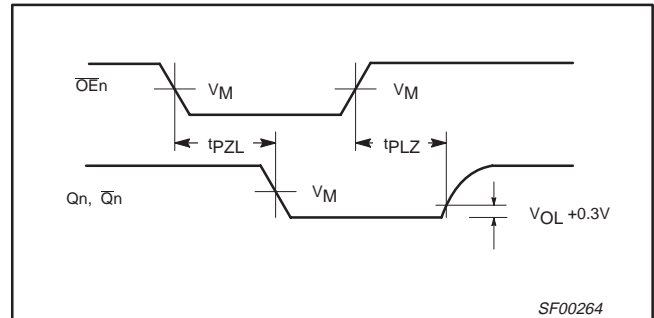

Waveform 7. 3-State output enable time to LOW level and output disable time from LOW level

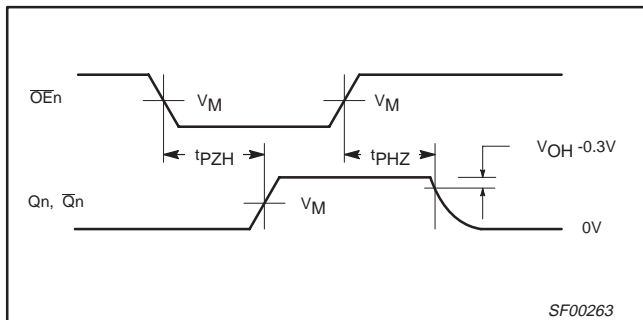

Waveform 6. 3-State output enable time to HIGH level and output disable time from HIGH level

TEST CIRCUIT AND WAVEFORMS

SWITCH POSITION	
TEST	SWITCH
t_{pLZ}, t_{pZL}	closed
All other	open

Test circuit for 3-state outputs

Input pulse definition

family	INPUT PULSE REQUIREMENTS					
	amplitude	V_M	rep. rate	t_w	t_{TLH}	t_{THL}
74F	3.0V	1.5V	1MHz	500ns	2.5ns	2.5ns

DEFINITIONS:

- R_L = Load resistor; see AC electrical characteristics for value.
- C_L = Load capacitance includes jig and probe capacitance; see AC electrical characteristics for value.
- R_T = Termination resistance should be equal to Z_{OUT} of pulse generators.

SF00265

Latch/flip-flop

74F373/74F374

DIP20: plastic dual in-line package; 20 leads (300 mil)

SOT146-1

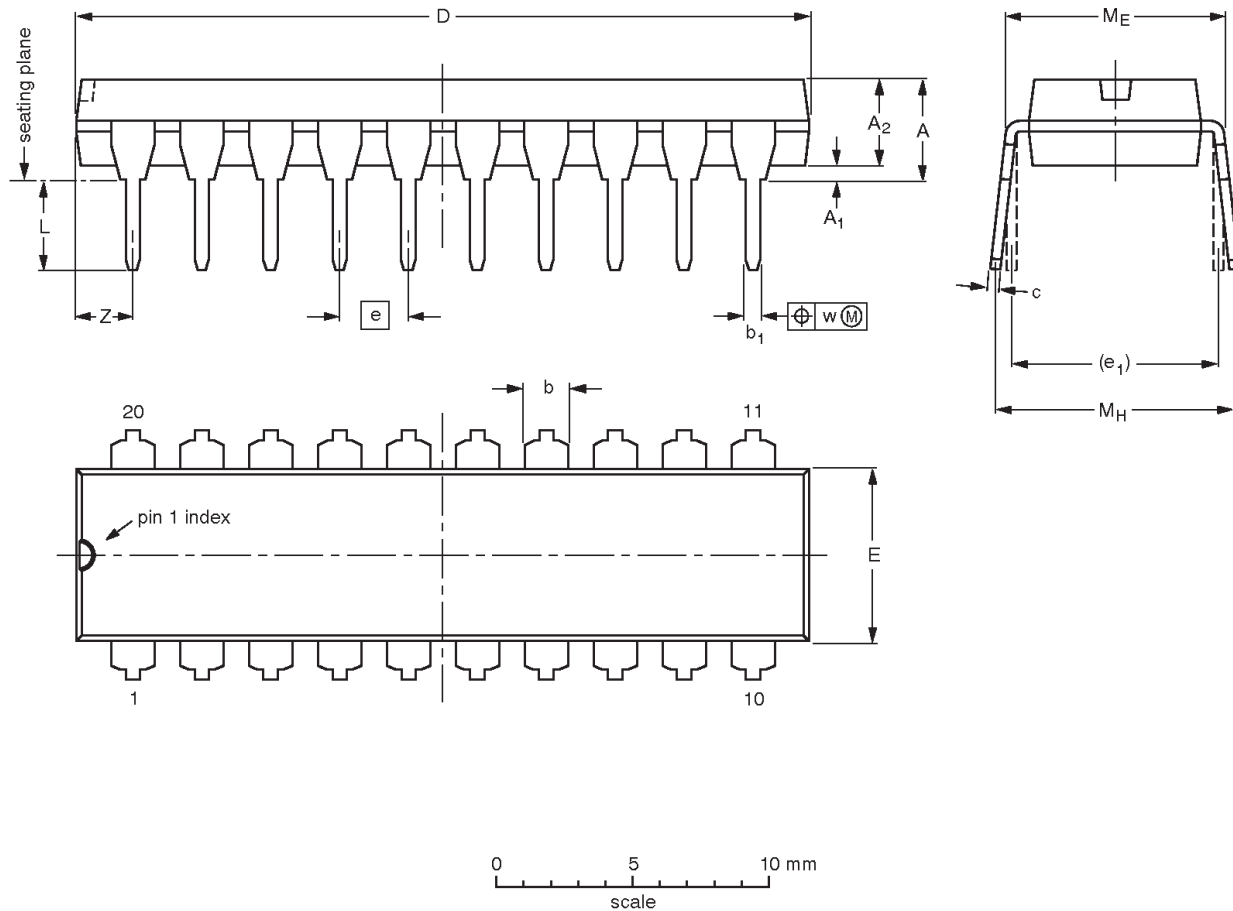

DIMENSIONS (inch dimensions are derived from the original mm dimensions)

UNIT	A max.	A ₁ min.	A ₂ max.	b	b ₁	c	D ⁽¹⁾	E ⁽¹⁾	e	e ₁	L	M _E	M _H	w	Z ⁽¹⁾ max.
mm	4.2	0.51	3.2	1.73 1.30	0.53 0.38	0.36 0.23	26.92 26.54	6.40 6.22	2.54	7.62	3.60 3.05	8.25 7.80	10.0 8.3	0.254	2.0
inches	0.17	0.020	0.13	0.068 0.051	0.021 0.015	0.014 0.009	1.060 1.045	0.25 0.24	0.10	0.30	0.14 0.12	0.32 0.31	0.39 0.33	0.01	0.078

Note

1. Plastic or metal protrusions of 0.25 mm maximum per side are not included.

OUTLINE VERSION	REFERENCES				EUROPEAN PROJECTION	ISSUE DATE
	IEC	JEDEC	EIAJ			
SOT146-1		MS-001	SC-603			95-05-24 99-12-27

Latch/flip-flop

74F373/74F374

SO20: plastic small outline package; 20 leads; body width 7.5 mm

SOT163-1

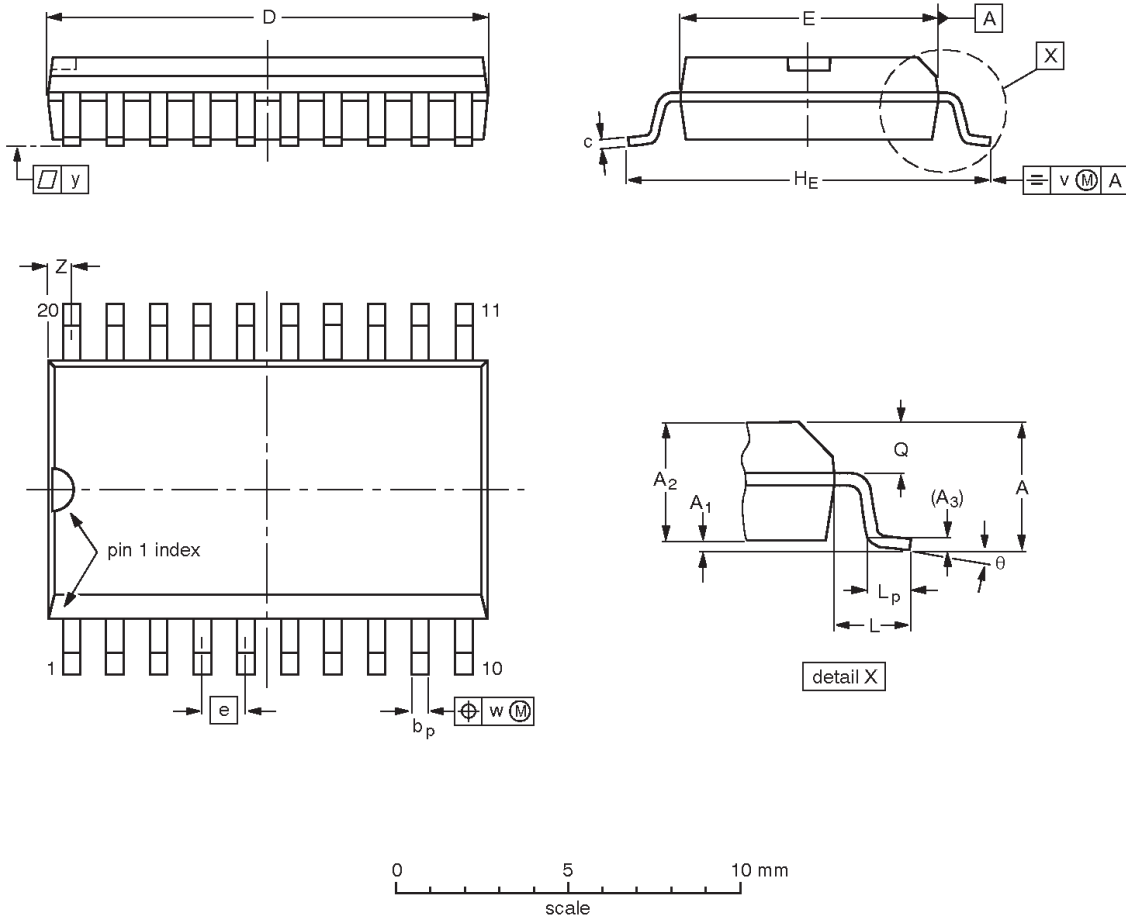

DIMENSIONS (inch dimensions are derived from the original mm dimensions)

UNIT	A max.	A ₁	A ₂	A ₃	b _p	c	D ⁽¹⁾	E ⁽¹⁾	e	HE	L	L _p	Q	v	w	y	z ⁽¹⁾	θ
mm	2.65	0.30 0.10	2.45 2.25	0.25	0.49 0.36	0.32 0.23	13.0 12.6	7.6 7.4	1.27	10.65 10.00	1.4	1.1 0.4	1.1 1.0	0.25	0.25	0.1	0.9 0.4	8° 0°
inches	0.10	0.012 0.004	0.096 0.089	0.01	0.019 0.014	0.013 0.009	0.51 0.49	0.30 0.29	0.050	0.419 0.394	0.055	0.043 0.016	0.043 0.039	0.01	0.01	0.004	0.035 0.016	

Note

1. Plastic or metal protrusions of 0.15 mm maximum per side are not included.

OUTLINE VERSION	REFERENCES				EUROPEAN PROJECTION	ISSUE DATE
	IEC	JEDEC	EIAJ			
SOT163-1	075E04	MS-013				97-05-22 99-12-27

Latch/flip-flop

74F373/74F374

SSOP20: plastic shrink small outline package; 20 leads; body width 5.3 mm

SOT339-1

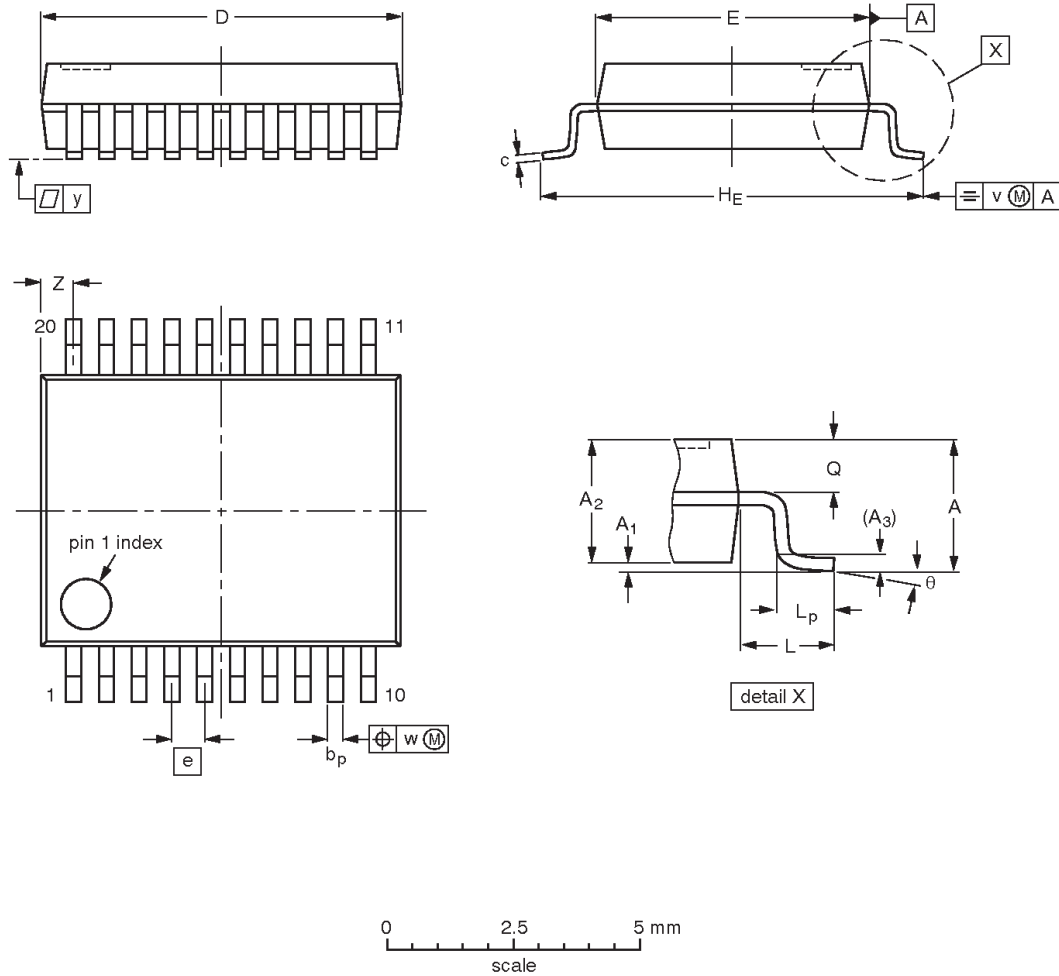

DIMENSIONS (mm are the original dimensions)

UNIT	A max.	A ₁	A ₂	A ₃	b _p	c	D ⁽¹⁾	E ⁽¹⁾	e	H _E	L	L _p	Q	v	w	y	Z ⁽¹⁾	θ
mm	2.0	0.21 0.05	1.80 1.65	0.25	0.38 0.25	0.20 0.09	7.4 7.0	5.4 5.2	0.65	7.9 7.6	1.25	1.03 0.63	0.9 0.7	0.2	0.13	0.1	0.9 0.5	8° 0°

Note

1. Plastic or metal protrusions of 0.20 mm maximum per side are not included.

OUTLINE VERSION	REFERENCES				EUROPEAN PROJECTION	ISSUE DATE
	IEC	JEDEC	EIAJ			
SOT339-1		MO-150				95-02-04 99-12-27

Latch/flip-flop

74F373/74F374

REVISION HISTORY

Rev	Date	Description
_3	20021120	Product data; third version (9397 750 10758). Supersedes 74F373_374_2 dated 1994 Dec 05 (9397 750 05119). Engineering Change Notice 853-0369 29206 (date: 20021115). Modifications: <ul style="list-style-type: none">• Corrected ordering information table (from 'N74374DB' to '74F374DB').• Add SSOP20 (SOT339-1) package outline drawing.
_2	19941205	Product data; second version (9397 750 05119). Engineering Change Notice 853-0369 14383 (date: 19941205).

Latch/flip-flop

74F373/74F374

Data sheet status

Level	Data sheet status ^[1]	Product status ^{[2] [3]}	Definitions
I	Objective data	Development	This data sheet contains data from the objective specification for product development. Philips Semiconductors reserves the right to change the specification in any manner without notice.
II	Preliminary data	Qualification	This data sheet contains data from the preliminary specification. Supplementary data will be published at a later date. Philips Semiconductors reserves the right to change the specification without notice, in order to improve the design and supply the best possible product.
III	Product data	Production	This data sheet contains data from the product specification. Philips Semiconductors reserves the right to make changes at any time in order to improve the design, manufacturing and supply. Relevant changes will be communicated via a Customer Product/Process Change Notification (CPCN).

[1] Please consult the most recently issued data sheet before initiating or completing a design.

[2] The product status of the device(s) described in this data sheet may have changed since this data sheet was published. The latest information is available on the Internet at URL <http://www.semiconductors.philips.com>.

[3] For data sheets describing multiple type numbers, the highest-level product status determines the data sheet status.

Definitions

Short-form specification — The data in a short-form specification is extracted from a full data sheet with the same type number and title. For detailed information see the relevant data sheet or data handbook.

Limiting values definition — Limiting values given are in accordance with the Absolute Maximum Rating System (IEC 60134). Stress above one or more of the limiting values may cause permanent damage to the device. These are stress ratings only and operation of the device at these or at any other conditions above those given in the Characteristics sections of the specification is not implied. Exposure to limiting values for extended periods may affect device reliability.

Application information — Applications that are described herein for any of these products are for illustrative purposes only. Philips Semiconductors make no representation or warranty that such applications will be suitable for the specified use without further testing or modification.

Disclaimers

Life support — These products are not designed for use in life support appliances, devices, or systems where malfunction of these products can reasonably be expected to result in personal injury. Philips Semiconductors customers using or selling these products for use in such applications do so at their own risk and agree to fully indemnify Philips Semiconductors for any damages resulting from such application.

Right to make changes — Philips Semiconductors reserves the right to make changes in the products—including circuits, standard cells, and/or software—described or contained herein in order to improve design and/or performance. When the product is in full production (status 'Production'), relevant changes will be communicated via a Customer Product/Process Change Notification (CPCN). Philips Semiconductors assumes no responsibility or liability for the use of any of these products, conveys no license or title under any patent, copyright, or mask work right to these products, and makes no representations or warranties that these products are free from patent, copyright, or mask work right infringement, unless otherwise specified.

Contact information

For additional information please visit
<http://www.semiconductors.philips.com>. Fax: +31 40 27 24825

© Koninklijke Philips Electronics N.V. 2002
 All rights reserved. Printed in U.S.A.

Date of release: 11-02

For sales offices addresses send e-mail to:
sales.addresses@www.semiconductors.philips.com

Document order number: 9397 750 10758

Let's make things better.

Looking for pricing, stock, or lifecycle information?

Click below to explore more details on WIN SOURCE:

 [View N74F374D,623 on WIN SOURCE](#)

 [NXP / Nexperia Information](#)

Optimize Your Supply Chain with WIN SOURCE Solutions

-  Global Sourcing Solution
-  Obsolete Management
-  Cost Control Management
-  Shortage Management
-  Alternative Solution
-  Excess Inventory Management