



**THE DATASHEET OF
N74F164N**



DATA SHEET

74F164

8-bit serial-in parallel-out shift register

Product specification
Supersedes data of 1995 Sep 22

2000 Dec 18

8-bit serial-in parallel-out shift register

74F164

FEATURES

- Gated serial data inputs
- Typical shift frequency of 100MHz
- Asynchronous Master Reset
- Buffered clock and data inputs
- Fully synchronous data transfer
- Industrial temperature range available (-40 to +85 °C)

DESCRIPTION

The 74F164 is an 8-bit edge-triggered shift register with serial data entry and an output from each of the eight stages. Data is entered through one of two inputs (Dsa, Dsb); either input can be used as an active High enable for data entry through the other input. Both inputs must be connected together or an unused input must be tied High.

Data shifts one place to the right on each Low-to-High transition of the clock (CP) input, and enters into Q0 the logical AND of the two data inputs (Dsa, Dsb) that existed one setup time before the rising edge. A Low level on the Master Reset (MR) input overrides all other inputs and clears the register asynchronously, forcing all outputs Low.

PIN CONFIGURATION

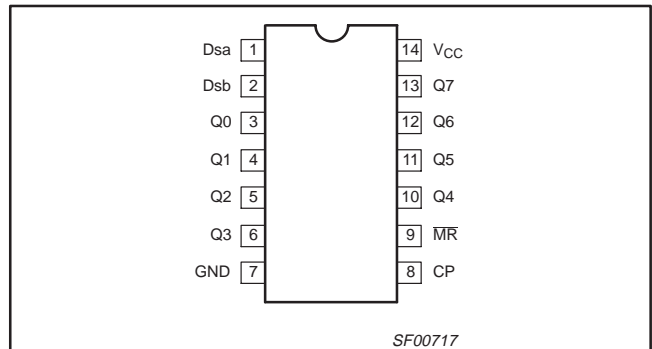

TYPE	TYPICAL f_{max}	TYPICAL SUPPLY CURRENT (TOTAL)
74F164	100MHz	33 mA

ORDERING INFORMATION

DESCRIPTION	ORDER CODE		DRAWING NUMBER
	COMMERCIAL RANGE $V_{CC} = 5 V \pm 10\%$, $T_{amb} = 0 \text{ to } +70 \text{ }^\circ\text{C}$	INDUSTRIAL RANGE $V_{CC} = 5 V \pm 10\%$, $T_{amb} = -40 \text{ to } +85 \text{ }^\circ\text{C}$	
14-pin plastic DIP	74F164N	I74F164N	SOT27-1
14-pin plastic SO	74F164D	I74F164D	SOT108-1

INPUT AND OUTPUT LOADING AND FAN OUT TABLE

PINS	DESCRIPTION	74F (U.L.) HIGH / LOW	LOAD VALUE HIGH / LOW
Dsa, Dsb	Data inputs	1.0 / 1.0	20 μA / 0.6 mA
CP	Clock pulse input (active rising edge)	1.0 / 1.0	20 μA / 0.6 mA
MR	Master reset input (active-Low)	1.0 / 1.0	20 μA / 0.6 mA
Q0 – Q7	Data outputs	50 / 33	1.0 mA / 20 mA

One (1.0) FAST unit load is defined as: 20 μA in the High state and 0.6 mA in the Low state.

LOGIC SYMBOL

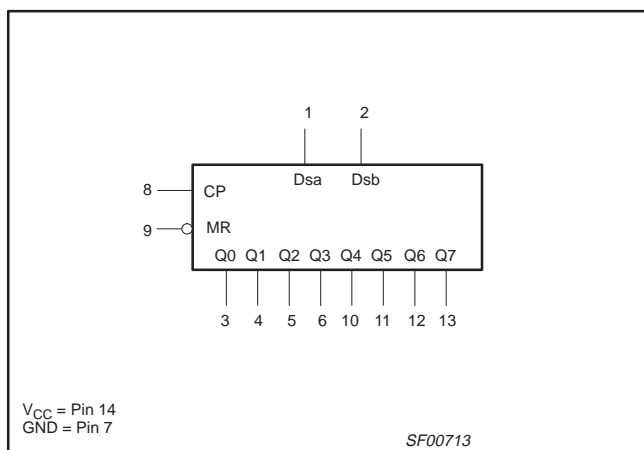

IEC/IEEE SYMBOL

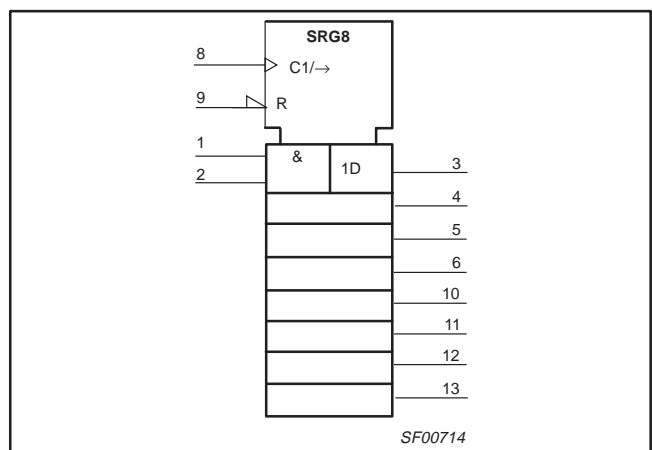

8-bit serial-in parallel-out shift register

74F164

LOGIC DIAGRAM

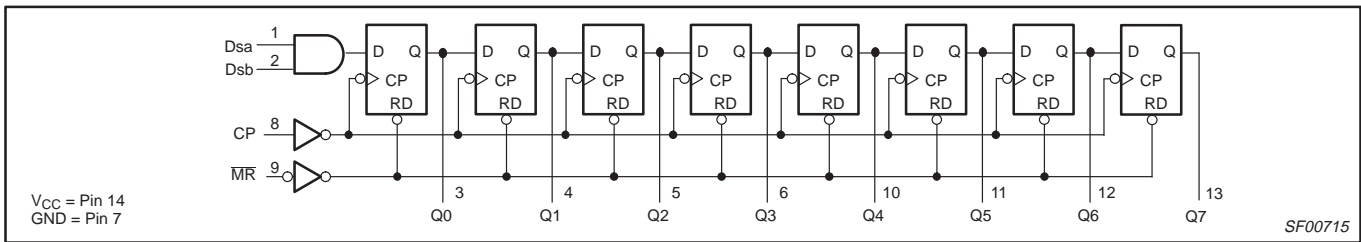

FUNCTION TABLE

INPUTS				OUTPUTS								OPERATING MODE	
MR	CP	Dsa	Dsb	Q0	Q1	Q2	Q3	Q4	Q5	Q6	Q7		
L	X	X	X	L	L	L	L	L	L	L	L	L	Reset (Clear)
H	↑	l	l	L	q0	q1	q2	q3	q4	q5	q6	q6	Shift
H	↑	h	l	L	q0	q1	q2	q3	q4	q5	q6	q6	
H	↑	h	h	H	q0	q1	q2	q3	q4	q5	q6	q6	

H = High voltage level
 h = High voltage level one setup time prior to the Low-to-High clock transition.
 L = Low voltage level
 l = Low voltage level one setup time prior to the Low-to-High clock transition.
 qn = Lower case letter indicate the state of the referenced output one setup time prior to the Low-to-High clock transition.
 X = Don't care
 ↑ = Low-to-High clock transition

ABSOLUTE MAXIMUM RATINGS

(Operation beyond the limit set forth in this table may impair the useful life of the device. Unless otherwise noted these limits are over the operating free air temperature range.)

SYMBOL	PARAMETER	RATING	UNIT
V _{CC}	Supply voltage	-0.5 to +7.0	V
V _{IN}	Input voltage	-0.5 to +7.0	V
I _{IN}	Input current	-30 to +5	mA
V _{OUT}	Voltage applied to output in High output state	-0.5 to V _{CC}	V
I _{OUT}	Current applied to output in Low output state	40	mA
T _{amb}	Operating free-air temperature range	Commercial Range	0 to +70
		Industrial Range	-40 to +85
T _{stg}	Storage temperature range	-65 to +150	°C

RECOMMENDED OPERATING CONDITIONS

SYMBOL	PARAMETER	LIMIT			UNIT
		MIN	NOM	MAX	
V _{CC}	Supply voltage	4.5	5.0	5.5	V
V _{IH}	High-level input voltage	2.0			V
V _{IL}	Low-level input voltage			0.8	V
I _{Ik}	Input clamp current			-18	mA
I _{OH}	High-level output current			-1	mA
I _{OL}	Low-level output current			20	mA
T _{amb}	Operating free-air temperature range	Commercial Range	0	+70	°C
		Industrial Range	-40	+85	

8-bit serial-in parallel-out shift register

74F164

DC ELECTRICAL CHARACTERISTICS

(Over recommended operating free-air temperature range unless otherwise noted.)

SYMBOL	PARAMETER	TEST CONDITIONS ¹	LIMITS			UNIT	
			MIN	TYP ²	MAX		
V _{OH}	High-level output voltage	V _{CC} = MIN, V _{IL} = MAX, V _{IH} = MIN, I _{OH} = MAX	±10%V _{CC}	2.5		V	
			±5%V _{CC}	2.7	3.4	V	
V _{OL}	Low-level output voltage	V _{CC} = MIN, V _{IL} = MAX, V _{IH} = MIN, I _{OL} = MAX	±10%V _{CC}		0.30	0.50	V
			±5%V _{CC}		0.30	0.50	V
V _{IK}	Input clamp voltage	V _{CC} = MIN, I _I = I _{IK}		-0.73	-1.2	V	
I _I	Input current at maximum input voltage	V _{CC} = MAX, V _I = 7.0 V			100	μA	
I _{IH}	High-level input current	V _{CC} = MAX, V _I = 2.7 V			20	μA	
I _{ILL}	Low-level input current	V _{CC} = MAX, V _I = 0.5 V			-0.6	mA	
I _{OS}	Short-circuit output current ³	V _{CC} = MAX	-60		-150	mA	
I _{CC}	Supply current (total) ⁴	V _{CC} = MAX		33	55	mA	

Notes to DC electrical characteristics

1. For conditions shown as MIN or MAX, use the appropriate value specified under recommended operating conditions for the applicable type.
2. All typical values are at V_{CC} = 5 V, T_{amb} = 25 °C.
3. Not more than one output should be shorted at a time. For testing I_{OS}, the use of high-speed test apparatus and/or sample-and-hold techniques are preferable in order to minimize internal heating and more accurately reflect operational values. Otherwise, prolonged shorting of a High output may raise the chip temperature well above normal and thereby cause invalid readings in other parameter tests. In any sequence of parameter test, I_{OS} tests should be performed last.
4. Measure I_{CC} with the serial inputs grounded, the clock input at 2.4 V, and a momentary ground, then applied to Master Reset, and all outputs open.

APPLICATION

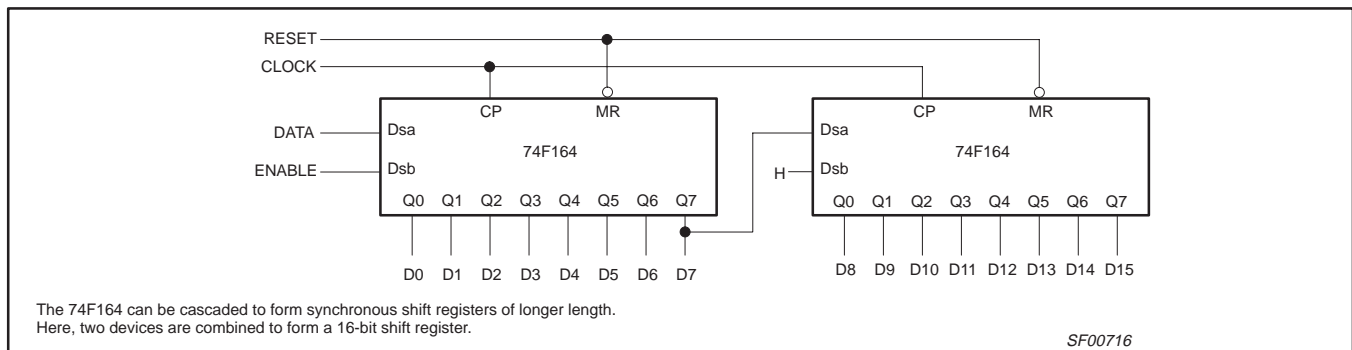

8-bit serial-in parallel-out shift register

74F164

AC ELECTRICAL CHARACTERISTICS

SYMBOL	PARAMETER	TEST CONDITION	LIMITS						UNIT	
			T _{amb} = +25 °C V _{CC} = 5 V C _L = 50 pF R _L = 500 Ω			T _{amb} = 0 to +70 °C V _{CC} = +5 V±10% C _L = 50 pF R _L = 500 Ω		T _{amb} = -40 to +85 °C V _{CC} = +5 V±10% C _L = 50 pF R _L = 500 Ω		
			MIN	TYP	MAX	MIN	MAX	MIN		MAX
f _{max}	Maximum clock frequency	Waveform 1	80	100		80		80		MHz
t _{PLH} t _{PHL}	Propagation delay CP to Q _n	Waveform 1	3.0 5.0	5.0 7.0	8.0 10.0	2.5 5.0	9.0 11.0	2.5 5.0	9.0 11.0	ns
t _{PHL}	Propagation delay MR to Q _n	Waveform 3	5.5	7.5	10.5	5.5	11.5	5.5	11.5	ns

AC SETUP REQUIREMENTS

SYMBOL	PARAMETER	TEST CONDITION	LIMITS						UNIT	
			T _{amb} = +25 °C V _{CC} = 5 V C _L = 50 pF R _L = 500 Ω			T _{amb} = 0 to +70 °C V _{CC} = +5 V±10% C _L = 50 pF R _L = 500 Ω		T _{amb} = -40 to +85 °C V _{CC} = +5 V±10% C _L = 50 pF R _L = 500 Ω		
			MIN	TYP	MAX	MIN	MAX	MIN		MAX
t _s (H) t _s (L)	Setup time, High or Low D _n to CP	Waveform 2	7.0 7.0			7.0 7.0		7.0 7.0		ns
t _h (H) t _h (L)	Hold time, High or Low D _n to CP	Waveform 2	1.0 1.0			2.0 2.0		2.0 2.0		ns
t _w (H) t _w (L)	CP Pulse width High or Low	Waveform 1	4.0 7.0			4.0 7.0		4.0 7.0		ns
t _w (L)	MR Pulse width Low	Waveform 3	7.0			7.0		7.0		ns
t _{REC}	Recovery time MR to CP	Waveform 3	7.0			7.0		7.0		ns

AC WAVEFORMS

For all waveforms, V_M = 1.5 V.

The shaded areas indicate when the input is permitted to change for predictable output performance.

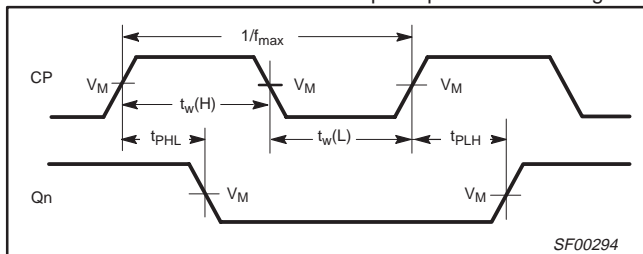

Waveform 1. Propagation delay for Clock input to output, Clock Pulse width, and maximum Clock frequency

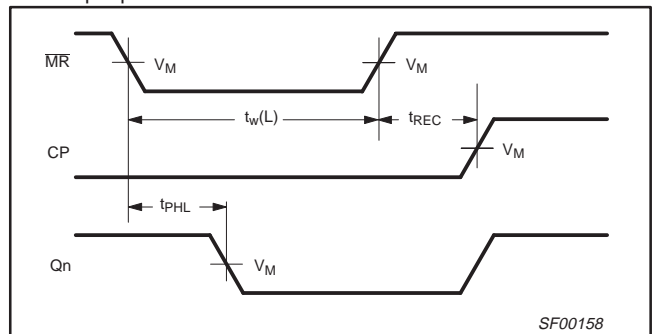

Waveform 3. Master Reset pulse width, Master Reset to output delay and Master Reset to Clock recovery time

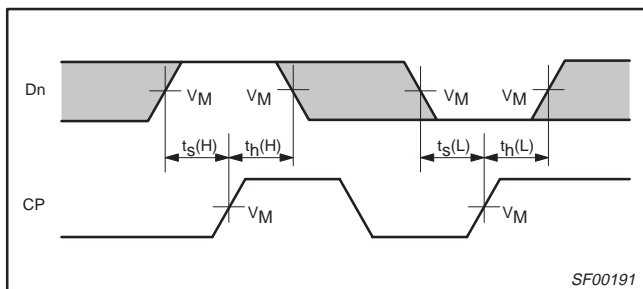

Waveform 2. Data setup and hold times

8-bit serial-in parallel-out shift register

74F164

TEST CIRCUIT AND WAVEFORMS

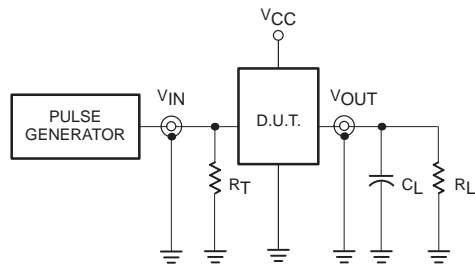

Test Circuit for Totem-Pole Outputs

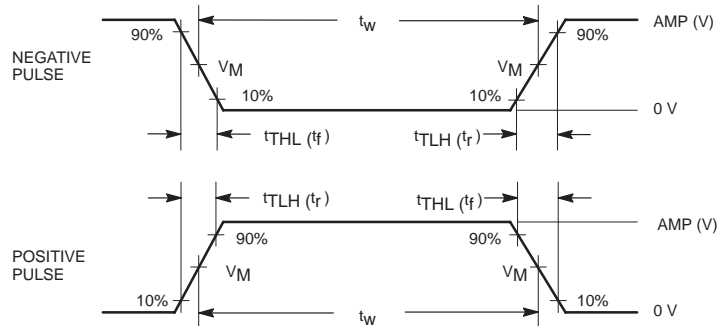

Input Pulse Definition

DEFINITIONS:

- R_L = Load resistor; see AC ELECTRICAL CHARACTERISTICS for value.
- C_L = Load capacitance includes jig and probe capacitance; see AC ELECTRICAL CHARACTERISTICS for value.
- R_T = Termination resistance should be equal to Z_{OUT} of pulse generators.

family	INPUT PULSE REQUIREMENTS					
	amplitude	V_M	rep. rate	t_w	t_{TLH}	t_{THL}
74F	3.0 V	1.5 V	1 MHz	500 ns	2.5 ns	2.5 ns

SF00006

8-bit serial-in parallel-out shift register

74F164

DIP14: plastic dual in-line package; 14 leads (300 mil)

SOT27-1

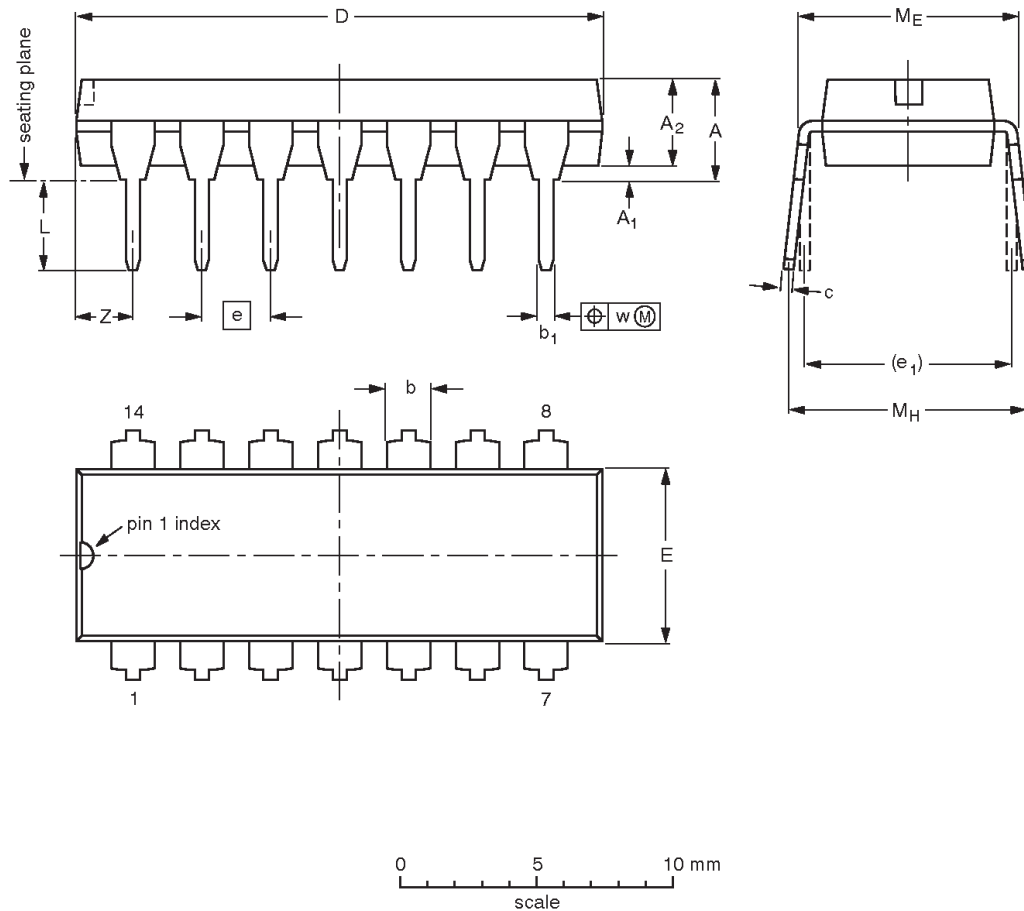

DIMENSIONS (inch dimensions are derived from the original mm dimensions)

UNIT	A max.	A ₁ min.	A ₂ max.	b	b ₁	c	D ⁽¹⁾	E ⁽¹⁾	e	e ₁	L	M _E	M _H	w	Z ⁽¹⁾ max.
mm	4.2	0.51	3.2	1.73 1.13	0.53 0.38	0.36 0.23	19.50 18.55	6.48 6.20	2.54	7.62	3.60 3.05	8.25 7.80	10.0 8.3	0.254	2.2
inches	0.17	0.020	0.13	0.068 0.044	0.021 0.015	0.014 0.009	0.77 0.73	0.26 0.24	0.10	0.30	0.14 0.12	0.32 0.31	0.39 0.33	0.01	0.087

Note

1. Plastic or metal protrusions of 0.25 mm maximum per side are not included.

OUTLINE VERSION	REFERENCES				EUROPEAN PROJECTION	ISSUE DATE
	IEC	JEDEC	EIAJ			
SOT27-1	050G04	MO-001	SC-501-14			95-03-11 99-12-27

8-bit serial-in parallel-out shift register

74F164

SO14: plastic small outline package; 14 leads; body width 3.9 mm

SOT108-1

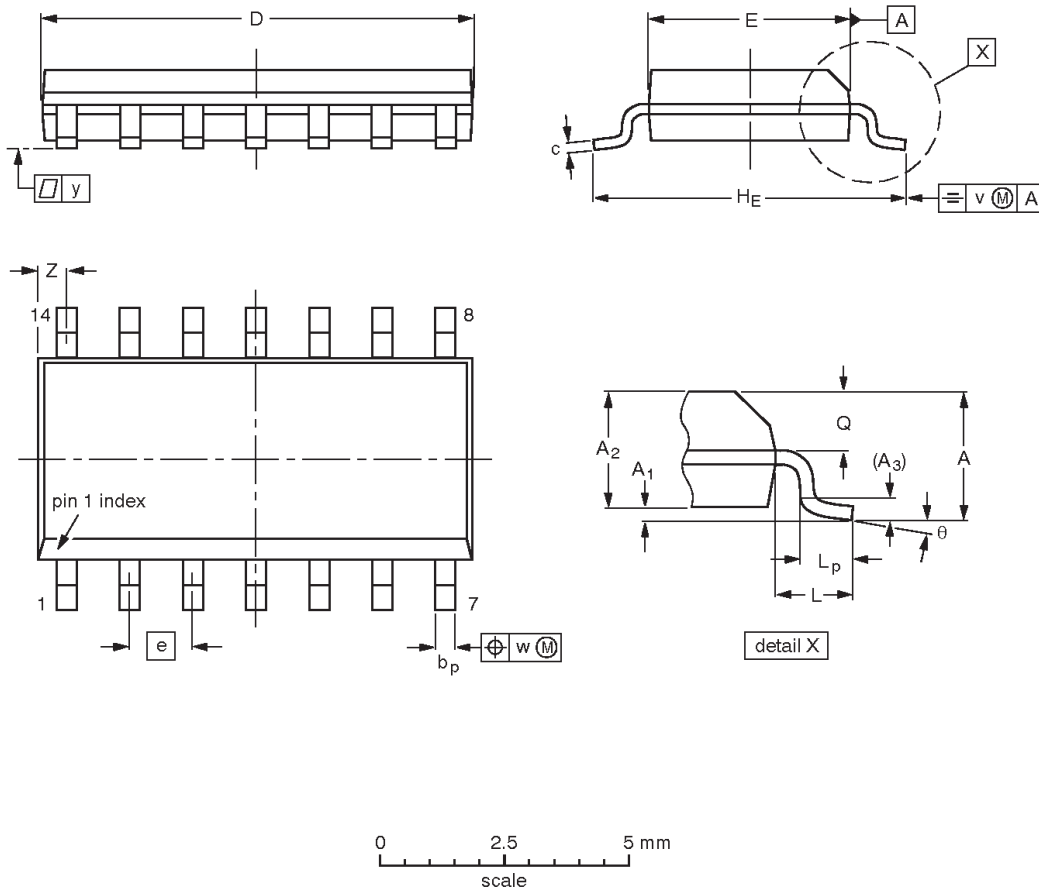

DIMENSIONS (inch dimensions are derived from the original mm dimensions)

UNIT	A max.	A ₁	A ₂	A ₃	b _p	c	D ⁽¹⁾	E ⁽¹⁾	e	H _E	L	L _p	Q	v	w	y	Z ⁽¹⁾	θ
mm	1.75	0.25 0.10	1.45 1.25	0.25	0.49 0.36	0.25 0.19	8.75 8.55	4.0 3.8	1.27	6.2 5.8	1.05	1.0 0.4	0.7 0.6	0.25	0.25	0.1	0.7 0.3	8° 0°
inches	0.069	0.010 0.004	0.057 0.049	0.01	0.019 0.014	0.0100 0.0075	0.35 0.34	0.16 0.15	0.050	0.244 0.228	0.041	0.039 0.016	0.028 0.024	0.01	0.01	0.004	0.028 0.012	

Note

1. Plastic or metal protrusions of 0.15 mm maximum per side are not included.

OUTLINE VERSION	REFERENCES				EUROPEAN PROJECTION	ISSUE DATE
	IEC	JEDEC	EIAJ			
SOT108-1	076E06	MS-012				97-05-22 99-12-27

8-bit serial-in parallel-out shift register

74F164

NOTES

8-bit serial-in parallel-out shift register

74F164

Data sheet status

Data sheet status	Product status	Definition [1]
Objective specification	Development	This data sheet contains the design target or goal specifications for product development. Specification may change in any manner without notice.
Preliminary specification	Qualification	This data sheet contains preliminary data, and supplementary data will be published at a later date. Philips Semiconductors reserves the right to make changes at any time without notice in order to improve design and supply the best possible product.
Product specification	Production	This data sheet contains final specifications. Philips Semiconductors reserves the right to make changes at any time without notice in order to improve design and supply the best possible product.

[1] Please consult the most recently issued datasheet before initiating or completing a design.

Definitions

Short-form specification — The data in a short-form specification is extracted from a full data sheet with the same type number and title. For detailed information see the relevant data sheet or data handbook.

Limiting values definition — Limiting values given are in accordance with the Absolute Maximum Rating System (IEC 134). Stress above one or more of the limiting values may cause permanent damage to the device. These are stress ratings only and operation of the device at these or at any other conditions above those given in the Characteristics sections of the specification is not implied. Exposure to limiting values for extended periods may affect device reliability.

Application information — Applications that are described herein for any of these products are for illustrative purposes only. Philips Semiconductors make no representation or warranty that such applications will be suitable for the specified use without further testing or modification.

Disclaimers

Life support — These products are not designed for use in life support appliances, devices or systems where malfunction of these products can reasonably be expected to result in personal injury. Philips Semiconductors customers using or selling these products for use in such applications do so at their own risk and agree to fully indemnify Philips Semiconductors for any damages resulting from such application.

Right to make changes — Philips Semiconductors reserves the right to make changes, without notice, in the products, including circuits, standard cells, and/or software, described or contained herein in order to improve design and/or performance. Philips Semiconductors assumes no responsibility or liability for the use of any of these products, conveys no license or title under any patent, copyright, or mask work right to these products, and makes no representations or warranties that these products are free from patent, copyright, or mask work right infringement, unless otherwise specified.

Philips Semiconductors
811 East Arques Avenue
P.O. Box 3409
Sunnyvale, California 94088-3409
Telephone 800-234-7381

© Copyright Philips Electronics North America Corporation 2001
All rights reserved. Printed in U.S.A.

Date of release: 01-01

Document order number:

9397 750 07889

Let's make things better.

Looking for pricing, stock, or lifecycle information?

Click below to explore more details on WIN SOURCE:

 [View N74F164N on WIN SOURCE](#)

 [NXP / Nexperia Information](#)

Optimize Your Supply Chain with WIN SOURCE Solutions

-  Global Sourcing Solution
-  Obsolete Management
-  Cost Control Management
-  Shortage Management
-  Alternative Solution
-  Excess Inventory Management