

1. DESCRIPTION

The N681386/87, implements a single channel FXS telephone line interface optimized for short loop applications. It integrates SLCC (Subscriber Line Control Circuit) functionality with a programmable CODEC and a DC/DC controller. The SLCC supports internal ringing up to 90 V_{PK} (5 REN at 4k ft) ideal for Customer Premise Equipment (CPE). The CODEC can be configured for μ -law, A-law or 16-bit linear PCM encoding. It also supports a comprehensive set of signaling capabilities required to supervise and control the telephone lines. These include tone generation, ring tones, DTMF detection/ generation as well as FSK generation. An on-chip Pulse Width Modulation (PWM) driver allows control of an inductor based DC/DC converter. Programmable impedance and trans-hybrid balancing allow for worldwide deployment.

2. FEATURES

- ◆ Complete BORSCHT functions
- ◆ Internal balanced and unbalanced ringing up to 90 V_{PK} (5 REN up to 4k ft)
- ◆ Integrated Power Management Options
 - Integrated DC/DC controller regulates battery voltage to minimize power dissipation in all operating modes
 - Programmable external battery switching
- ◆ Programmable linefeed characteristics
 - Ringing Frequency, Amplitude, and Cadence
 - Trapezoidal and Sinusoidal waveforms
 - Two wire AC impedance, and trans-hybrid balance
 - Constant Current feed (20 to 41) mA
 - Ring Trip and Loop Closure Thresholds
 - Ground Key Detection
- ◆ Programmable signal generation and detection
 - DTMF generation/ detection and Tone generation
 - Frequency Shift Keying (FSK) Enhanced Caller ID generation (Type I and Type II)
- ◆ Loop test and diagnostics support
 - Integrated loopback modes
 - Real-time linefeed monitoring
 - On-chip temperature sensor
 - Line Card Diagnostics Support
- ◆ Digital interfaces
 - PCM: G.711 μ -Law, A-Law and 16-bit linear
 - GCI and SPI bus
 - Programmable audio path gains
- ◆ Both PCM Master and Slave modes supported
- ◆ On-chip PLL for flexible clocking options including 1.0 MHz and 2.0 MHz BCLK operation
- ◆ Operating voltage: 3.3V

- ◆ Narrowband Codec (N681386)
- ◆ Wideband and Narrowband codec (N681387)
- ◆ Optional integrated (N681622) or discrete Subscriber Line Feed Circuit

APPLICATIONS

- ◆ Residential VoIP Gateways / Routers/ IP-PBX
- ◆ Fiber to the Premise/Home (FTTP/H)
- ◆ Wireless Local Loop
- ◆ Optical Network Terminals (ONT)
- ◆ Analog Telephone Adapter (ATA)
- ◆ Voice enabled DSL/Cable Modems
- ◆ Integrated Access Devices
- ◆ Set Top Boxes

Ordering Information

Part Number	Temp Range (°C)	Package	Package Material
N681386DG N681387DG	-40 to 85	48-LQFP	Pb-Free
N681386YG N681387YG	-40 to 85	48-QFN	Pb-Free
N681622YG	-40 to 85	20-QFN	Pb-Free

! WARNING !

HIGH VOLTAGE WARNING USE EXTREME CAUTION



High voltage sources could cause serious injury or death if not used in accordance with design and/or user specifications, if they are used by untrained or unqualified personnel. Before testing Nuvoton's products read and understand all instructions, and safety procedures as in industry standard safe practices.

3. PIN CONFIGURATION

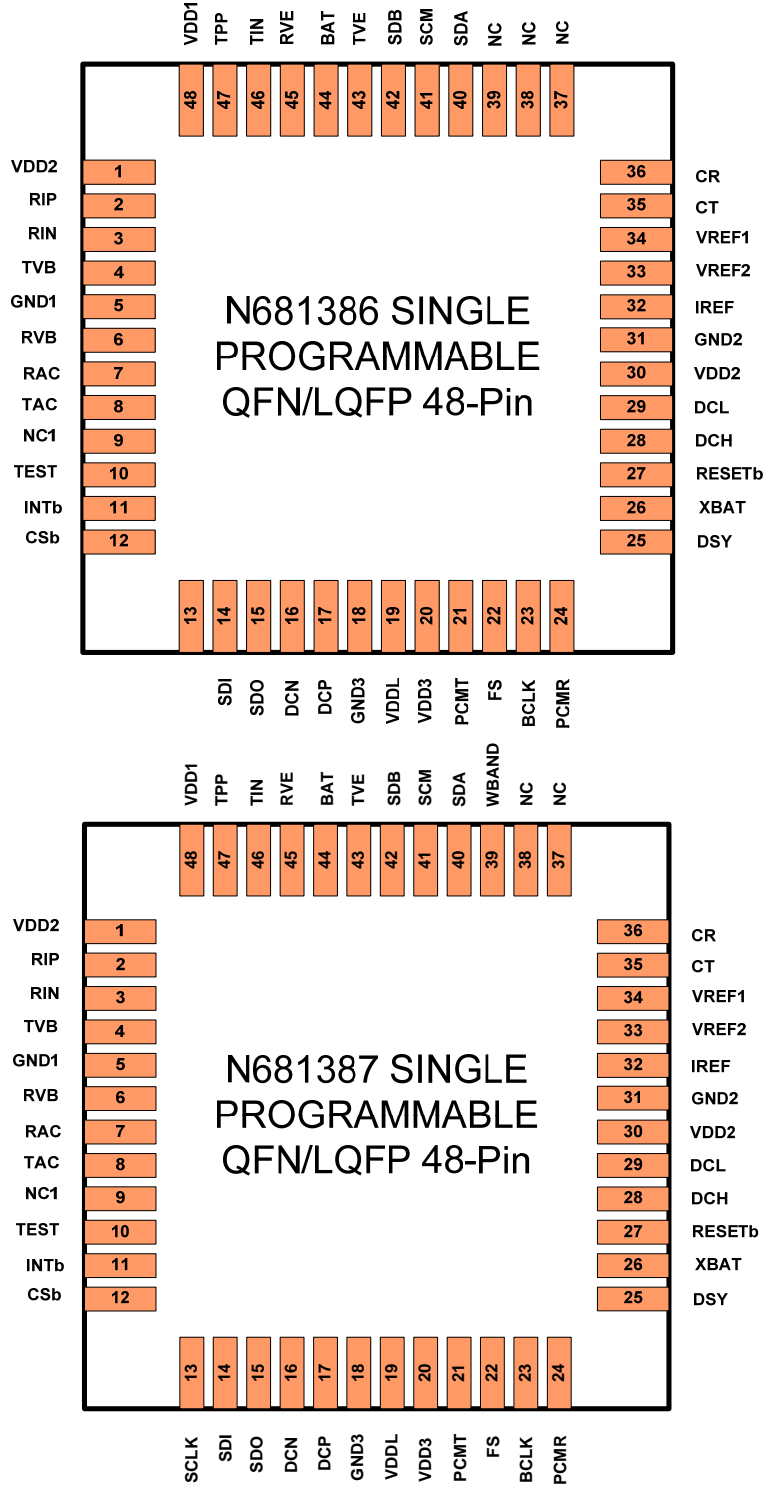

Figure 1: N681386/87 Pin Configuration

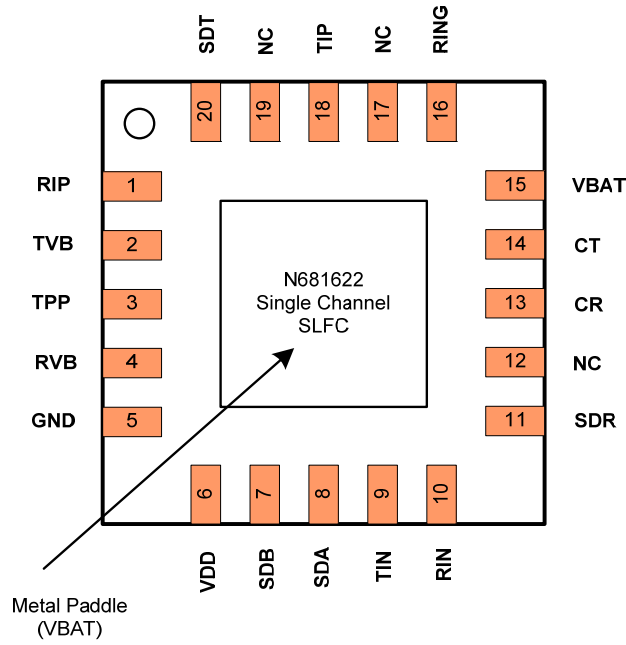

Figure 2: N681622 Subscriber Line Feed Circuit (SLFC) Pin Configuration

4. PIN DESCRIPTION

4.1. N681386/87 Pin Description

Pin Name	Pin No.	Functionality	A/D	Pin Type
VDD1	1	Line-driver 3.3 V supply	A	P
RIP	2	Positive RING Driver current source & Voltage sense	A	I/O
RIN	3	Negative RING Driver current source	A	O
TVB	4	Positive TIP Driver Base Voltage Control	A	O
GND	5	Line-driver ground supply	A	G
RVB	6	Positive RING Driver Base Voltage Control	A	O
RAC	7	RING Voice Band Input	A	I
TAC	8	TIP Voice Band Input	A	I
NC	9	No connect		
TEST	10	For internal testing only. Needs to be tied to ground during normal operation	D	I
INTb	11	Interrupt. Maskable interrupt. Open drain output for wired-or operation	D	O
CSb	12	Chip Select. When inactive, SCLK and SDI are ignored and SDO is high impedance. When active, serial port is operational	D	I
SCLK	13	Serial port bit clock. Controls serial data on SDO and latches data on SDI	D	I
SDI	14	Serial port data in. Serial port control data	D	I
SDO	15	Serial port data out. Serial port control data	D	O
DCN	16	DC/DC converter Control for external NPN BJT	D	O
DCP	17	DC/DC Converter Control for external PNP BJT	D	O
GND3	18	Logic I/O ground supply	D	G
VDDL	19	Logic supply voltage. This pin should not be connected up to an external supply. Use only as shown in application diagram.	D	I/O
VDD3	20	3.3 V Logic I/O supply	D	P
PCMT	21	Serial PCM Transmit data	D	O
FS	22	8 or 16 kHz Frame Sync	D	I/O
BCLK	23	PCM Bit Clock. Also used as internal PLL reference clock	D	I
PCMR	24	Serial PCM Receive data	D	I
DSY	25	SPI Daisy Chain Enable	D	I
XBAT	26	External Battery Supply Enable. Disables DC/DC Controller when set high	D	I
RESETb	27	Reset. Active Low. Hardware reset used to place all control registers in default state.	D	I

Pin Name	Pin No.	Functionality	A/D	Pin Type
DCH	28	DC/DC Converter Current Sense Higher input Voltage	A	I
DCL	29	DC/DC Converter Current Sense Lower input Voltage	A	I
VDD2	30	3.3 V Analog AC path and reference Supply Voltage	A	P
GND2	31	Analog AC path and reference Supply ground	A	P
IREF	32	Current Reference	A	I/O
VREF2	33	Precision Reference Voltage	A	I/O
VREF1	34	Mid Supply Reference Voltage	A	I/O
CT	35	External Capacitor TIP	A	I/O
CR	36	External Capacitor RING	A	I/O
NC	37	No Connect		
NC	38	No Connect		
WBAND	39	Wideband enable (only on N681387)	D	I
SDA	40	Subscriber Loop Differential sense signal A from linefeed circuit	A	I
SCM	41	Subscriber Common Mode sense signal from linefeed circuit	A	I
SDB	42	Subscriber Loop Differential sense signal B from linefeed circuit	A	I
TVE	43	TIP line-driver emitter voltage sense	A	I
BAT	44	Battery voltage monitoring	A	I
RVE	45	RING line-driver emitter voltage sense	A	I
TIN	46	Negative TIP Driver current source	A	O
TPP	47	Positive TIP Driver current source & Voltage sense	A	I/O
VDD1	48	Line-driver 3.3 V supply	A	P

Table 1: N681386/87 Pin Description

A	Analog
D	Digital
G	Ground

O	Output
I	Input
P	Power

4.2. N681622 Pin Description

Pin Name	Pin No.	Functionality	Type	Pin Type
RIP	1	Ring Driver Pull up Current from 34.8 Ohm resistor	LV	I/O
TVB	2	Tip Pull-Up Driver control voltage	LV	I
TPP	3	Tip Driver Pull up Current from 34.8 Ohm resistor	LV	I/O
RVB	4	Ring Pull-Up Driver control voltage	LV	I
GND	5	Supply ground (0V)	LV	G
VDD	6	3.3V Supply	LV	P
SDB	7	Subscriber differential signal B	LV	O
SDA	8	Subscriber differential signal A	LV	O
TIN	9	Tip DC Pull-Down current	LV	I
RIN	10	Ring DC Pull-Down current	LV	I
SDR	11	Subscriber differential Ring input	HV	I/O
NC	12	Not connected		
CR	13	Ring Pull-Down filter capacitor	HV	I/O
CT	14	Tip Pull-Down filter capacitor	HV	I/O
VBAT	15	Battery Supply Voltage	HV	P
RING	16	Ring terminal	HV	O
NC	17	Not connected		
TIP	18	Tip terminal	HV	O
NC	19	Not connected		
SDT	20	Subscriber differential Tip input	HV	I/O

Table 2: N681622 Pin Description

LV	Low Voltage
HV	High Voltage
G	Ground

O	Output
I	Input
P	Power

5. BLOCK DIAGRAM

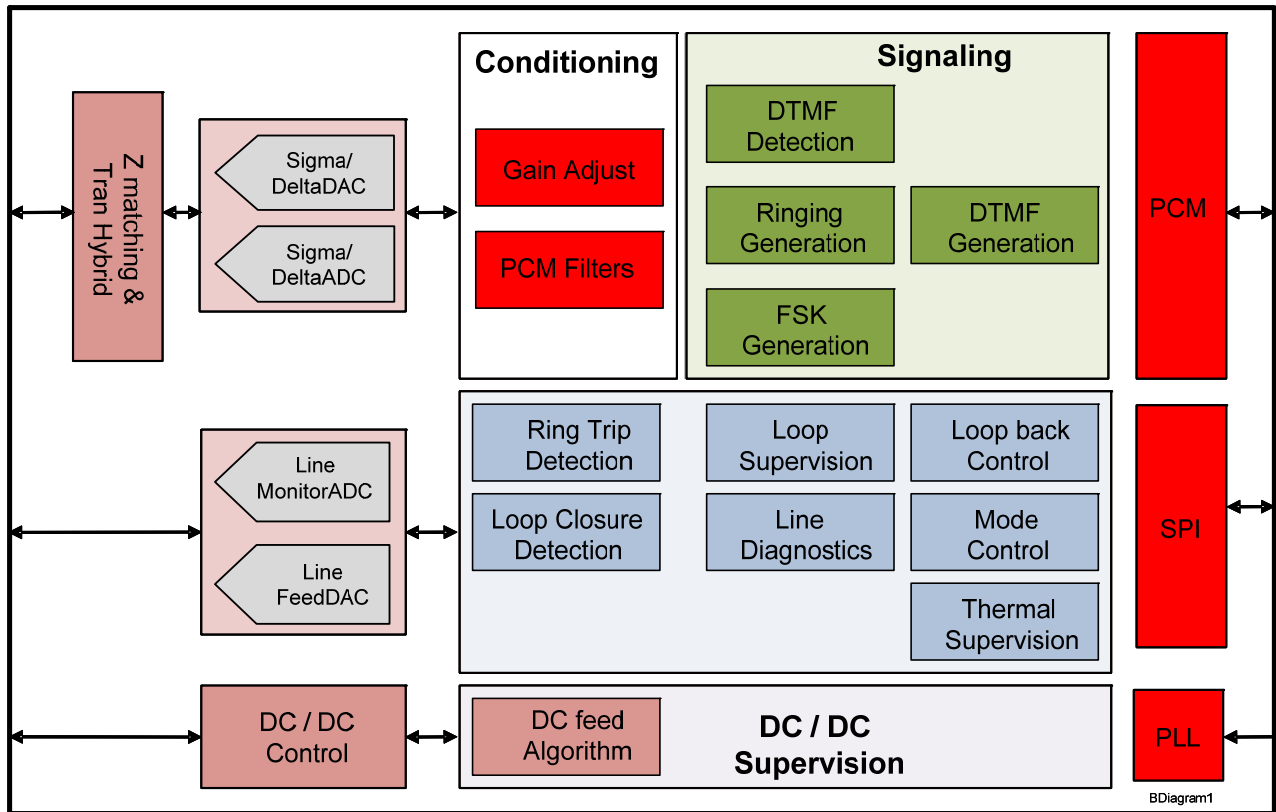

Figure 3: N681386/87 Block Diagram

6. TABLE OF CONTENTS

1.	DESCRIPTION	1
2.	FEATURES	1
3.	PIN CONFIGURATION	2
4.	PIN DESCRIPTION	4
4.1.	N681386/87 PIN DESCRIPTION	4
4.2.	N681622 PIN DESCRIPTION	6
5.	BLOCK DIAGRAM.....	7
6.	TABLE OF CONTENTS	8
7.	LIST OF FIGURES	15
8.	LIST OF TABLES	17
9.	ABSOLUTE MAXIMUM RATINGS	18
9.1.	SINGLE PROGRAMMABLE EXTENDED CODEC/SLCC (N681386/87)	18
9.2.	SUBSCRIBER LINE FEED CIRCUIT (N681622)	18
10.	OPERATING CONDITIONS.....	19
10.1.	SINGLE PROGRAMMABLE EXTENDED CODEC/SLCC (N681386/87)	19
10.2.	SUBSCRIBER LINE FEED CIRCUIT (N681622)	19
11.	ELECTRICAL CHARACTERISTICS.....	20
11.1.	GENERAL PARAMETERS (N681386/87).....	20
11.2.	SUPPLY PARAMETERS DISCRETE SOLUTION (N681386/87 AND DISCRETE LINE DRIVER)	20
11.3.	SUPPLY PARAMETERS SLFC SOLUTION (N681386/87 AND N681622)	21
11.4.	MONITORING A/D PARAMETERS.....	22
11.5.	ANALOG SIGNAL LEVEL AND GAIN PARAMETERS	22
11.6.	2-WIRE TO 4-WIRE CONVERSION PARAMETERS.....	23
11.7.	2-WIRE PARAMETERS	23
11.8.	LINEFEED CHARACTERISTICS	23
11.9.	ANALOG DISTORTION AND NOISE PARAMETERS	24
12.	FUNCTIONAL DESCRIPTION	25
12.1.	BORSCHT FUNCTIONALITY	26
12.1.1.	BATTERY FEED	26
12.1.1.1.	LINEFEED STATES OF OPERATION	28
12.1.1.1.1.	OPEN STATE.....	28
12.1.1.1.2.	ACTIVE, IDLE AND ON-HOOK TRANSMISSION STATES.....	28
12.1.1.1.3.	TIP OPEN STATE	28
12.1.1.1.4.	RING OPEN STATE.....	29
12.1.1.1.5.	RINGING STATE.....	29
12.1.1.1.6.	CALIBRATION STATE	29
12.1.1.2.	OPERATION MODES	29

12.1.1.3.	AUTOMATIC TRANSITIONS	29
12.1.1.3.1.	POWER ALARM AUTOMATIC REACT	29
12.1.1.3.2.	SETTING RING AUTOMATIC	29
12.1.1.3.3.	SETTING LOOP CLOSURE DETECT AUTOMATIC REACT	30
12.1.1.4.	POLARITY REVERSAL.....	32
12.1.1.4.1.	HARD POLARITY REVERSAL	32
12.1.1.4.2.	SOFT POLARITY REVERSAL	32
12.1.1.5.	WINK FUNCTION POLARITY REVERSAL.....	33
12.1.2.	OVER-VOLTAGE PROTECTION.....	33
12.1.2.1.	THERMAL OVERLOAD	34
12.1.2.2.	TEMPERATURE MONITOR	35
12.1.3.	RINGING	35
12.1.3.1.	TONE GENERATION.....	36
12.1.3.2.	RING SIGNAL GENERATION.....	39
12.1.3.2.1.	SINUSOIDAL RINGING	41
12.1.3.2.2.	TRAPEZOIDAL RINGING	42
12.1.3.2.3.	RINGING DC OFFSET AND COMMON MODE BIAS.....	43
12.1.3.2.4.	LINEFEED CONSIDERATIONS DURING RINGING	44
12.1.3.3.	INTERNAL UNBALANCED RINGING	44
12.1.3.4.	RING TRIP DETECTION.....	45
12.1.4.	SUPERVISION (SIGNALING).....	47
12.1.4.1.	LOOP CLOSURE DETECTION.....	47
12.1.4.2.	GROUND KEY DETECTION.....	49
12.1.4.3.	CALLER ID AND FSK GENERATION.....	50
12.1.4.4.	DTMF GENERATOR.....	51
12.1.4.5.	DTMF DETECTION.....	53
12.1.5.	CODEC	54
12.1.6.	HYBRID.....	54
12.1.6.1.	AC PATH.....	54
12.1.6.1.1.	NARROWBAND TRANSMIT PATH	54
12.1.6.1.2.	NARROWBAND RECEIVE PATH.....	54
12.1.6.1.3.	ANALOG TRANSHYBRID BALANCING	55
12.1.6.1.4.	IMPEDANCE MATCHING	56
12.1.6.1.5.	DAC/ADC AUTOMUTE	57
12.1.7.	TESTING.....	58
12.1.7.1.	LOOP BACK TESTS	58
12.1.7.2.	DIAGNOSTICS SUPPORT	59
12.1.8.	POWER INTERFACE.....	59

12.1.8.1.	DC/DC CONVERSION (INDUCTOR).....	60
12.1.8.2.	EXTERNAL BATTERY SWITCHING.....	62
12.2.	DIGITAL INTERFACE	63
12.2.1.	CLOCK GENERATION	63
12.2.2.	PCM INTERFACE	64
12.2.2.1.	WIDEBAND AND NARROWBAND OPERATION	65
12.2.2.2.	TOGGLING BETWEEN WIDEBAND AND NARROWBAND	66
12.2.2.3.	PCM INTERFACE IN WIDEBAND OPERATION	66
12.2.2.3.1.	PCM INTERFACE 8KHZ FRAME SYNC.....	66
12.2.2.3.2.	PCM INTERFACE 16KHZ FRAME SYNC.....	67
12.2.2.4.	PLL & PRESCALER IN WIDEBAND OPERATION	67
12.2.3.	SERIAL PERIPHERAL INTERFACE (SPI).....	68
12.2.4.	READ/WRITE SEQUENCE (8-BIT OR 16-BIT).....	69
12.2.5.	SPI DAISY CHAIN.....	71
12.2.6.	SPI BURST MODE.....	72
12.2.7.	SPECIAL READ SEQUENCE FOR 12-BIT WIDE REGISTER	73
12.2.7.1.	12-BIT READ SEQUENCE.....	73
12.3.	POWER-ON RESET	74
12.4.	INTERRUPT HANDLING	75
13.	GENERAL DESCRIPTION FOR N681622 (LINEFEED CIRCUIT).....	76
13.1.	FUNCTIONAL DESCRIPTION FOR N681622 (LINEFEED CIRCUIT).....	76
14.	REGISTER DESCRIPTION.....	77
14.1.	PCM CONTROL REGISTERS	82
14.1.1.	PCM CONTROL REGISTER.....	82
14.1.2.	RECEIVE/TRANSMIT TIMESLOT (WIDEBAND AND NARROWBAND)	82
14.1.3.	PLL STATUS REGISTER.....	83
14.1.4.	PCM FREQUENCY SETTING REGISTER	84
14.1.5.	SILICON VERSION ID REGISTER (READ ONLY)	85
14.1.6.	DEVICE VERSION ID REGISTER (READ ONLY)	85
14.1.7.	TIMESLOT (WIDEBAND).....	85
14.2.	FSK REGISTERS.....	86
14.2.1.	FSK CONTROL REGISTER.....	86
14.2.2.	FSK TRANSMIT REGISTER.....	86
14.2.3.	FSK STATUS REGISTER (READ ONLY)	87
14.2.4.	FSK LCR REGISTER.....	87
14.2.5.	FSK TCR REGISTER.....	88
14.3.	DIAGNOSTIC REGISTERS	89
14.3.1.	DIAGNOSTIC CONTROL 0.....	89

14.3.2.	DIAGNOSTIC CONTROL 1.....	89
14.3.3.	DIAGNOSTIC CONTROL 2, 3, 4. AND 5.....	90
14.3.4.	DIAGNOSTIC CONTROL 6 AND 7 (READ ONLY).....	91
14.3.5.	DIAGNOSTIC CONTROL 8 (READ ONLY).....	92
14.3.6.	DIAGNOSTIC FIFO 0 AND FIFO1 (READ ONLY).....	92
14.4.	SYSTEM REGISTERS.....	93
14.4.1.	PCM HPF (HIGH PASS FILTER).....	93
14.4.2.	LOOP BACK CONTROL REGISTER.....	93
14.4.3.	POWER ON.....	94
14.4.4.	LINEFEED TRIM.....	95
14.5.	INTERRUPT REGISTERS.....	96
14.5.1.	INTERRUPT VECTOR LOW (READ ONLY).....	96
14.5.2.	INTERRUPT STATUS REGISTER 1.....	96
14.5.3.	INTERRUPT ENABLE REGISTER 1.....	97
14.5.4.	INTERRUPT STATUS REGISTER 2.....	97
14.5.5.	INTERRUPT ENABLE REGISTER 2.....	98
14.5.6.	INTERRUPT STATUS REGISTER 3.....	98
14.5.7.	INTERRUPT ENABLE REGISTER 3.....	99
14.6.	DTMF DETECTION REGISTER.....	100
14.6.1.	DTMF CONTROL 1.....	100
14.6.2.	DTMF CONTROL 2.....	101
14.6.3.	DTMF CONTROL 3.....	101
14.6.4.	DTMF STATUS (READ ONLY).....	102
14.6.5.	DTMF THRESHOLD.....	102
14.6.6.	DTMF PRESENT DETECT TIME.....	102
14.6.7.	DTMF ABSENT DETECT TIME.....	103
14.6.8.	DTMF ACCEPT TIME.....	103
14.6.9.	DTMF RECEIVE DATA STATUS.....	104
14.6.10.	DTMF ROW FREQUENCY.....	104
14.6.11.	14/15 DTMF COLUMN FREQUENCY.....	105
14.7.	LINE REGISTERS.....	106
14.7.1.	AC PATH GAIN.....	106
14.7.2.	HYBRID BALANCE.....	106
14.7.3.	COMMON RINGING BIAS ADJUST DURING RINGING.....	107
14.7.4.	LINE AUTOMATIC MANUAL CONTROL.....	107
14.7.5.	LINEFEED STATUS.....	108
14.7.6.	LOOP CURRENT LIMIT.....	108
14.7.7.	RING TRIP DETECT STATUS/ LOOP CLOSURE STATUS (READ ONLY).....	109

14.7.8.	LOOP CLOSURE DEBOUNCE	110
14.7.9.	RING TRIP DEBOUNCE INTERVAL.....	110
14.7.10.	PWM PERIOD	110
14.7.11.	DC/DC CONTROLLER CONTROL	111
14.7.12.	ON-HOOK VOLTAGE	111
14.7.13.	GROUND MARGIN VOLTAGE	112
14.7.14.	HIGH BATTERY VOLTAGE	112
14.7.15.	LOW BATTERY VOLTAGE.....	112
14.7.16.	LOOP CLOSURE DETECT/RING TRIP DETECT COEFFICIENT.....	113
14.7.17.	LOOP CLOSURE DETECT THRESHOLD WITHOUT / WITH HYSTERESIS	113
14.7.18.	RING TRIP DETECT THRESHOLD	114
14.7.19.	OFFSET VOLTAGE	114
14.7.20.	DC/DC TIME ON	114
14.7.21.	DAC/ADC AUTOMUTE FUNCTION.....	115
14.8.	GROUND KEY DETECTION.....	116
14.8.1.	LINEFEED CONTROL	116
14.8.2.	GROUND KEY DETECT HIGH/LOW THRESHOLD	116
14.8.3.	GROUND KEY DETECT DEBOUNCE TIME	117
14.8.4.	GROUND KEY DETECT FILTER COEFFICIENT LOW/ HIGH.....	117
14.8.5.	DC RING TRIP DEBOUNCE FILTER COEFFICIENT LOW.....	117
14.8.6.	DC RING TRIP CURRENT THRESHOLD.....	118
14.8.7.	DC RING TRIP DEBOUNCE TIME	118
14.8.8.	EXTERNAL BATTERY SWITCH OUTPUT CONFIGURATION 1	119
14.8.9.	DC/DC HEAVY CURRENT CONVERTER	119
14.8.10.	DC/DC TARGET VOLTAGE (READ ONLY).....	120
14.9.	MONITORING REGISTERS	121
14.9.1.	MONITOR CURRENT FOR RING TRIP AND LOOP CLOSURE.....	121
14.9.2.	MONITOR CURRENT FOR RING TRIP AND LOOP CLOSURE.....	121
14.10.	LINE CONTROL REGISTERS	122
14.10.1.	VOLTAGE REGISTERS.....	122
14.10.1.1.	BATTERY VOLTAGE SENSE (READ ONLY).....	122
14.10.1.2.	TIP/RING VOLTAGE SENSE (READ ONLY).....	122
14.10.1.3.	TIP/RING TRANSISTOR 3 EMITTER VOLTAGE SENSE (READ ONLY)	122
14.11.	TRANSISTOR CURRENT REGISTERS (TIP/RING TRANSISTOR 1/2/3 CURRENT SENSE).....	123
14.12.	LOOP SUPERVISION	124
14.12.1.	LONGITUDINAL CURRENT	124
14.12.2.	LOOP VOLTAGE SENSE (READ ONLY)	124
14.12.3.	TIP, RING, AND LOOP CURRENT (READ ONLY).....	125

14.12.4.	POLARITY.....	125
14.12.5.	COMMON MODE VOLTAGE.....	126
14.12.6.	TIP EMITTER VOLTAGE FOR TRANSISTORS QT1 SENSE (READ ONLY).....	126
14.12.7.	TIP VOLTAGE FOR TRANSISTOR QT1 SENSE (READ ONLY).....	126
14.12.8.	RING EMITTER VOLTAGE FOR TRANSISTOR QT1 SENSE (READ ONLY).....	127
14.12.9.	RING VOLTAGE FOR TRANSISTOR QT1 SENSE (READ ONLY).....	127
14.12.10.	TEMPERATURE SENSE (READ ONLY).....	127
14.12.11.	BAND GAP VOLTAGE.....	127
14.12.12.	PEAK TO PEAK LOOP VOLTAGE (READ ONLY).....	128
14.12.13.	PEAK TO PEAK LOOP CURRENT (READ ONLY).....	128
14.13.	POWER ALARM LPF POLE REGISTERS.....	129
14.13.1.	POWER ALARM COUNTER.....	129
14.13.2.	POWER ALARM LOW PASS FILTER POLE FOR TRANSISTORS 1/2/3.....	129
14.13.3.	POWER ALARM THRESHOLD FOR TRANSISTOR 1-3.....	130
14.14.	IMPEDANCE MATCHING 1/2.....	130
14.14.1.	TEMPERATURE ALARM THRESHOLD.....	131
14.14.2.	LOOP CLOSURE MASK COUNT.....	131
14.14.3.	COARSE CALIBRATION INTERNAL RESISTOR.....	131
14.14.4.	OSCILLATOR 2 RINGING PHASE DELAY.....	131
14.15.	CALIBRATION.....	132
14.16.	DC OFFSET REGISTERS.....	133
14.16.1.	DC OFFSET (RING, TIP, AND VBAT).....	133
14.16.2.	PWM COUNT (READ ONLY).....	133
14.17.	tone GENERATION REGISTERS.....	134
14.17.1.	OSCILLATOR CONTROL.....	134
14.17.2.	RING CONTROL.....	134
14.17.3.	OSCILLATOR 1 AND 2 INITIAL CONDITION LOW/HIGH.....	134
14.17.4.	OSCILLATOR 1 AND 2 COEFFICIENT LOW/HIGH.....	135
14.18.	OSCILLATOR 1 AND 2 ACTIVE/ INACTIVE TIME LOW/HIGH.....	135
14.19.	GENERAL TONE GENERATION.....	136
14.19.1.	RING OFFSET.....	136
14.19.2.	ADC/DAC DIGITAL GAIN.....	136
14.19.3.	PWM DC/DC FINE TUNING.....	137
14.19.4.	PWM DC/DC FINE TUNING SKIP PERIOD.....	137
14.19.5.	PWM DC/DC FINE TUNING.....	138
14.19.6.	IMPEDANCE MATCH REGISTER.....	139
14.19.6.1.	IMPEDANCE MATCHING COEFFICIENT RAM.....	139
14.19.6.2.	IMPEDANCE MATCHING DELAY COUNT.....	139

14.19.6.3.	IMPEDANCE MATCHING COEFFICIENT RAM CONTROL	139
14.19.6.4.	PCM SCALING.....	140
14.19.6.5.	RESERVED REGISTERS	140
14.19.6.6.	FILTER BYPASS.....	140
15.	TIMING DIAGRAM	141
15.1.	PCM TIMING DIAGRAM FOR NON-GCI	141
15.2.	PCM TIMING DIAGRAM FOR GCI	142
15.3.	SPI TIMING DIAGRAM	144
16.	DIGITAL I/O.....	150
16.1.1.	μ-LAW ENCODE DECODE CHARACTERISTICS	150
16.2.	A-LAW ENCODE DECODE CHARACTERISTICS.....	151
16.3.	μ-LAW / A-LAW CODES FOR ZERO AND FULL SCALE	151
16.3.1.	μ-LAW / A-LAW CODES FOR 0DBM0 OUTPUT (DIGITAL MILLIWATT).....	152
16.4.	16-BIT LINEAR PCM CODES FOR ZERO AND FULL SCALE.....	152
16.5.	16-BIT LINEAR PCM CODES FOR 1 KHZ DIGITAL MILLIWATT.....	152
17.	TYPICAL APPLICATION CIRCUITS	153
17.1.	DC/DC APPLICATION	153
17.2.	DISCRETE LINE DRIVER.....	154
17.3.	DC DC	155
17.4.	TRIPLE BATTERY SWITCH APPLICATION.....	156
17.5.	N681386/87 DCDC APPLICATION USE WITH SLFC N681622.....	157
17.6.	N681622 LINEFEED CIRCUIT	158
18.	PACKAGE SPECIFICATION.....	159
18.1.	LQFP-48 (10X10X1.4MM FOOTPRINT 2.0MM)	159
18.2.	QFN-48.....	160
18.3.	QFN 20L 4X4 MM ² , PITCH:0.50 MM.....	161
19.	ORDERING INFORMATION	162
20.	VERSION HISTORY	163

7. LIST OF FIGURES

Figure 1: N681386/87 Pin Configuration2

Figure 2: N681622 Subscriber Line Feed Circuit (SLFC) Pin Configuration3

Figure 3: N681386/87 Block Diagram7

Figure 4: AC signal Path25

Figure 5: DC Feed Regions26

Figure 6: Line Loop Control.....27

Figure 7: Example State Diagram30

Figure 8: Block Diagram Oscillator 1.....38

Figure 9: Zero Crossing for Tone Generation39

Figure 10: Trapezoidal Ringing42

Figure 11: Positive DC offset for Trapezoidal Ringing.....43

Figure 12: Programming V_{CMR} voltage for Trapezoidal Ringing43

Figure 13: Unbalanced Ringing on TIP44

Figure 14: RING Trip Detection Mechanism45

Figure 15: Loop Closure Detector Block Diagram47

Figure 16: Ground Key Detection Circuitry.....49

Figure 17: The Architecture of Linear FSK Waveform Generator.....50

Figure 18: DTMF Detector - Functional Block Diagram.....53

Figure 19: Characteristic Line Impedance.....56

Figure 20: Diagnostics Support Block Diagram.....59

Figure 21: Voltage Tracking in Forward Active State61

Figure 22: Dynamic Battery Target61

Figure 23: Three Voltage External Battery switching62

Figure 24: Two Battery Supply Control Circuit62

Figure 25: Wideband 8kHz Frame Sync PCM interface66

Figure 26: Wideband 16kHz Frame Sync PCM interface67

Figure 27: Register write operation through a 8-bit SPI port70

Figure 28: Register read operation through a 8-bit SPI port.....70

Figure 29: Register write operation through a 16-bit SPI port70

Figure 30: Register read operation through a 16-bit SPI port.....70

Figure 31: Three Chip Daisy Chain connection.....71

Figure 32: Device/Register Address for Three Device Daisy Chain application71

Figure 33: DATA for Three Device Daisy Chain application.....72

Figure 34: Burst mode operation (BST=1)72

Figure 35: SPI 12-bits Read sequence74

Figure 36: N681622 Equivalent Internal diagram.....76

Figure 37: PCM Timing for Non-GCI141

Figure 38: GCI PCM Timing 142

Figure 39: SPI Timing (Non-Daisy Chain Mode) 144

Figure 40: In-band Transmit Frequency Response 145

Figure 41: In-band Receive Frequency Response 145

Figure 42: Transmit Group Delay Distortion 146

Figure 43: Receive Group Delay Distortion 146

Figure 44: 2-Wire to PCM Signal to Distortion Mask (A-Law) 147

Figure 45: 2-Wire to PCM Signal to Distortion Mask (μ -Law) 147

Figure 46: Wideband In-band Transmit Frequency Response 148

Figure 47: Wideband Transmit Group Delay Distortion 148

Figure 48: Wideband Receive Group Delay Distortion 149

Figure 49: Typical Application Block Diagram 153

Figure 50: Discrete Line-driver 154

Figure 51: Inductor based circuit 12V supply 155

Figure 52: Triple Battery based Switch 1 156

Figure 53: N681386/87 Pro-X Application diagram to be used with N681622 157

Figure 54: N681622 Linefeed circuit 158

8. LIST OF TABLES

Table 1: N681386/87 Pin Description.....	5
Table 2: N681622 Pin Description.....	6
Table 3: Programmable Ranges for DC Line Feed	26
Table 4: Linefeed States	28
Table 5: Operation Modes.....	29
Table 6: Associated Registers for Linefeed Control	30
Table 7: TIP and RING Voltage Targets	31
Table 8: Registers Associated with Line Monitoring – Measured.....	31
Table 9: Registers Associated with Line Monitoring – Calculated.....	31
Table 10: Registers for Polarity Reversal.....	33
Table 11: PWM DC/DC Power Alarm Counter.....	34
Table 12: Registers Associated with Thermal Overload.....	34
Table 13: Associated Registers for Oscillator Control (Oscillator 1 Example).....	36
Table 14: Example Register settings for Oscillator m.....	37
Table 15: Registers for RING Generation	40
Table 16: Example Ringer Register settings	41
Table 17: Registers for RING Trip Detection.....	46
Table 18: Recommended RING Trip Values for Ringing.....	46
Table 19: Loop Closure Detection Registers.....	48
Table 20: Ground Key Detection Registers	49
Table 21: Registers for FSK Generation	51
Table 22: DTMF frequency mapping.....	51
Table 23: Digital Gain Adjust Coefficients and Attenuation weightings	55
Table 24: Examples of Resistive Impedance Matching.....	56
Table 25: Examples of Complex Impedance Matching	57
Table 26: Registers for Automute.....	57
Table 27: Registers associated with DC/DC Conversion	60
Table 28: Example Standard Interface modes	64
Table 29: Wideband or Narrowband Hardware Selection	65
Table 30: PLL and Prescaler in Wideband.....	67
Table 31: Device Address Bit pattern.....	68
Table 32: 12-bit byte Selection.....	69
Table 33: Interrupt Registers.....	75

9. ABSOLUTE MAXIMUM RATINGS

9.1. Single Programmable Extended Codec/SLCC (N681386/87)

Condition	Value
Junction temperature	150°C
Storage temperature range	-65°C to +150°C
LQFP-48 Thermal Resistance, typical	76 °C/W
QFN-48 Thermal Resistance, typical	27.1 °C/W
Voltage applied to any pin	(V _{SS} - 0.3V) to (V _{DD} + 0.3V)
Input current applied to any digital input pin	+/- 10 mA
ESD (Human Body Model)	2000 V
V _{DD} - V _{SS}	-0.5V to +3.63V
Power Dissipation	0.7W

1. Stresses above those listed may cause permanent damage to the device. Exposure to the absolute maximum ratings may affect device reliability. Functional operation is not implied at these conditions.

9.2. Subscriber Line Feed Circuit (N681622)

Parameter	Symbol	Value	Unit
VDD Supply Voltage	VDD	-0.5 - 5	V
VBAT Supply Voltage	VBAT	-104	V
Input Voltage HV IO	VINHV	(VBAT-0.3) to (VDD+0.3)	V
Input Voltage LV IO	VINLV	-0.3 to (VDD+0.3)	V
ESD, HBM		JESD22 Class 1C	V
Operating Temperature **	TA	-40 - 100	C
Storage Temperature	TS	-40 - 150	C
Thermal Resistance QFN20	Rthja	45	C/W
Power Dissipation	Pmax	0.9	W

** When the dice temperature reaches over 130°C, the device reliability may be adversely affected.

10. OPERATING CONDITIONS

10.1. Single Programmable Extended Codec/SLCC (N681386/87)

Condition	Symbol	Min	Typ	Max	Unit
Industrial operating temperature	TA	-40		+85	C
Supply voltage (V _{DD})	VDD	3.13		3.47	V
Ground voltage (V _{SS})	VSS		0		V

Note: Exposure to conditions beyond those listed under Absolute Maximum Ratings may adversely affect the life and reliability of the device.

10.2. Subscriber Line Feed Circuit (N681622)

Parameter	Symbol	Min	Typ	Max	Unit
Industrial operating temperature	TA	-40		85	C
Supply voltage (V _{DD})	VDD	3.13	3.3	3.47	V
VBAT Supply Voltage	VBAT	-100	-	-9	V

11. ELECTRICAL CHARACTERISTICS

11.1. GENERAL PARAMETERS (N681386/87)

$V_{DD}=3.13\text{ V to }3.47\text{ V}$; $V_{SS}=0\text{ V}$; $T_A = -40^{\circ}\text{C to }+85^{\circ}\text{C}$;

Symbol	Parameters	Conditions	Min (2)	Typ (1)	Max (2)	Units
V_{IL}	Logic Input LOW Voltage		-0.3	--	0.8	V
V_{IH}	Logic Input HIGH Voltage		2	--	3.6	V
V_T	Threshold point			1.41		V
V_{OL}	Logic Output LOW Voltage	INTB,FS,PCMT,SDO: $I_{OL} = 4\text{ mA}$ DCP, DCN: $I_{OL} = 16\text{ mA}$	--	--	0.4	V
V_{OH}	Logic Output HIGH Voltage	FS,PCMT,SDO: $I_{OH} = 4\text{ mA}$ DCP, DCN: $I_{OH} = 16\text{ mA}$	2.4	--		V
I_{IL}	Input HIGH & LOW Leakage Current	$V_{SS}<V_{IN}<V_{DD}$ No pull-up or pull-down	--	--	+/-10	μA
I_{OZ}	Tri-state Leakage Current	$V_{SS}<V_O<V_{DD}$ High Z State	--	--	+/-10	μA
C_{IN}	Digital Input Capacitance		--	3	--	pF
C_{OUT}	Digital Output Capacitance	V_O High Z	--	3	--	pF

1. Typical values: $T_A = 25^{\circ}\text{C}$, $V_{DD} = 3.3\text{ V}$

2. All min/max limits are guaranteed by Nuvoton via electrical testing or characterization. Not all specifications are 100 percent tested.

11.2. SUPPLY PARAMETERS DISCRETE SOLUTION (N681386/87 AND DISCRETE LINE DRIVER)

$V_{DD}=3.13\text{ V to }3.47\text{ V}$; $V_{SS}=0\text{ V}$; $T_A=-40^{\circ}\text{C to }+85^{\circ}\text{C}$;

Symbol	Parameters	Conditions	Min	Typ (1)	Max (2)	Units
I_{PD}	Total Power Down Supply Current	RESETb = 0V, Vdd1..Vdd3 FS=BCLK=0V		12	100	μA
I_{SB}	Total Standby Supply Current	RESETb = VDD, VDD1 .. VDD3 FS=BCLK=0V, Line state Open		8.0	11.3	mA
I_{VDD}	Total Supply Current for all supplies @3.3V (linefeed states)	Open (ADC and DAC disabled)		21		mA
		Forward/Reverse Active $I_{LIM}=20\text{ mA}$		66		mA
		Forward/Reverse ON-HOOK Transmission		45		mA
		Forward/Reverse Idle (ADC and DAC disabled)		29		mA
		TIP/RING Open		28		mA
		Ringin, Sine wave, REN=1, $V_{PK}=56\text{ V}$		50		mA
I_{VBAT}	Total Battery Supply	Open, VBAT = 72V		0.72		mA

Symbol	Parameters	Conditions	Min	Typ (1)	Max (2)	Units
	Current	Forward/Reverse Active $I_{LIM}=20$ mA,		30		mA
		Forward/Reverse ON-HOOK Transmission, XBTA:XTBOT=0, VBAT = 54V		12		mA
		Forward/Reverse Idle, VBAT = 54V		1.3		mA
		TIP/RING Open, VBAT = 54V		1.0		mA
		Ringling, Sine wave, REN=1, VBAT = 71V		6.0		mA

1. Typical values: $T_A = 25^{\circ}\text{C}$, $V_{DD} = 3.3\text{ V}$
2. All min/max limits are guaranteed by Nuvoton via electrical testing or characterization. Not all specifications are 100 percent tested.
3. The supply current for the DC/DC converter can be calculated by : $IDC/DC=IVBAT*VBAT/(efficiency*VDC/DC)$

11.3. SUPPLY PARAMETERS SLFC SOLUTION (N681386/87 AND N681622)

Parameter	Symbol	Condition	MIN	TYP	Max	Unit
VDD Supply Current	IDDO	Open State		24.0		mA
	IDDI	Low Power Idle State, VBAT=-50V		21.4		mA
	IDDA	Active State		63.3		mA
	IDDR	Ringling, 1REN, 40Vrms		TBD		mA
	IDDOT	On-Hook Transmit		47.9		mA
	IDDTO	Tip/Ring Open		TBD		mA
VBAT Supply Current	IBTO	Open State		0.4		mA
	IBTI	Low Power Idle State, VBAT=-50V	-	0.2	1.2	mA
	IBTA	Active State		29.0		mA
	IBTR	Ringling, 1REN, 40Vrms		TBD		mA
	IBTOT	On-Hook Transmit		14.1		mA
	IBTTO	Tip/Ring Open		TBD		mA

11.4. MONITORING A/D PARAMETERS

$V_{DD}=3.13\text{ V to }3.47\text{ V}$; $V_{SS}=0\text{ V}$; $T_A=-40^{\circ}\text{C to }+85^{\circ}\text{C}$

Symbol	Parameters	Min	Typ	Max	Units
INL	Integral Nonlinearity (8-bit resolution)		+/-0.5		LSB
DNL	Differential Nonlinearity (8-bit resolution)		+/-0.5		LSB
	Gain Error (Current)			20	%
	Gain Error (Voltage)			10	%
	Sample Rate per channel	--	--	800	Hz
	Number of channels	--	16	--	

Typically at 12-bit the INL and DNL is 2 LSB.

11.5. ANALOG SIGNAL LEVEL AND GAIN PARAMETERS

$V_{DD}=3.13\text{ V to }3.47\text{ V}$; $V_{SS}=0\text{ V}$; $T_A=-40^{\circ}\text{C to }+85^{\circ}\text{C}$; Loading $600\ \Omega$

PARAMETER	SYM.	CONDITION	TYP.	TRANSMIT (A/D)		RECEIVE (D/A)		UNIT
				MIN.	MAX.	MIN.	MAX.	
Absolute Level	L_{ABS}	0 dBm0 = 0 dBm @ 600 Ω	1.0954	---	---	---	---	V_{PK}
Max. Transmit Level	T_{XMAX}	3.17 dBm0 for u-Law 3.14 dBm0 for A-Law ⁽¹⁾	1.5779 1.5725	---	---	---	---	V_{PK} V_{PK}
Absolute Gain (0 dBm0 @ 1020 Hz; $T_A=+25^{\circ}\text{C}$)	G_{ABS}	0 dBm0 @ 1020 Hz, $V_{DD}=3.3\text{V}$; $T_A=+25^{\circ}\text{C}$; assuming ideal line impedance matching	0	-0.40	+0.40	-0.40	+0.40	dB
Absolute Gain variation with Temperature	G_{ABST}	$T_A=0^{\circ}\text{C to }T_A=+70^{\circ}\text{C}$ $T_A=-40^{\circ}\text{C to }T_A=+85^{\circ}\text{C}$	0	-0.10 -0.20	+0.10 +0.20	-0.10 -0.20	+0.10 +0.20	dB
Absolute Gain variation with Supply Voltage	G_{ABSS}	$V_{DD}=3.13\text{ V} - 3.47\text{ V}$; 0dBm0 @ 1020 Hz; $T_A=+25^{\circ}\text{C}$	0	-0.10	+0.10	-0.10	+0.10	dB
Frequency Response	G_{RTV}		See Figure					
Gain Variation vs. Level Tone (1020 Hz relative to -10 dBm0)	G_{LT}	+3 to -40 dBm0	---	-0.3	+0.3	-0.3	+0.3	dB
		-40 to -50 dBm0	---	-0.6	+0.6	-0.6	+0.6	
		-50 to -60 dBm0	---	-1.6	+1.6	-1.6	+1.6	
Gain Step Variation	G_{ST}	-6 dB to 6 dB	0	-	+/- 0.025	-	+/-0.025	dB
Absolute Group Delay	T_{ABS}	1200 Hz	---	633	650	286	300	usec
Group Delay Distortion (relative to group delay @ 1200 Hz)	T_D		See Figure					

1. Default Gain Setting

11.6. 2-WIRE TO 4-WIRE CONVERSION PARAMETERS

$V_{DD}=3.13\text{ V to }3.47\text{ V}$; $V_{SS}=0\text{ V}$; $T_A=-40^{\circ}\text{C to }+85^{\circ}\text{C}$; Loading $600\ \Omega$

PARAMETER	SYM.	CONDITION	MIN.	TYP.	MAX.	UNIT
Return Loss	R _L	200 Hz to 3.4 kHz, 600 Ohm	26	40		dB
Trans hybrid Balance	H _B	200 Hz to 3.4 kHz, 600 Ohm	26	40		dB

11.7. 2-WIRE PARAMETERS

$V_{DD}=3.13\text{ V to }3.47\text{ V}$; $V_{SS}=0\text{ V}$; $T_A=-40^{\circ}\text{C to }+85^{\circ}\text{C}$; Loading $600\ \Omega$

PARAMETER	SYM.	CONDITION	MIN	TYP	MAX	UNIT
Longitudinal Conversion Loss	L _{CL}	300 Hz to 600 Hz	40		---	dB
		600 Hz to 3.4 kHz,	46			
Longitudinal to Metallic or PCM Balance	L _{ML}	300 Hz to 600 Hz	40	52	---	dB
	L _{MH}	600 Hz to 3.4 kHz,	46	55	---	dB
Longitudinal Impedance	L _Z	300 Hz to 3.4 kHz	---	18.5		Ohms
Longitudinal Current	L _I	Active OFF-HOOK; 300 Hz to 3.4 kHz	---	6.7		mA

11.8. LINEFEED CHARACTERISTICS

$V_{DD}=3.13\text{ V to }3.47\text{ V}$; $V_{SS}=0\text{ V}$; $T_A=-40^{\circ}\text{C to }+85^{\circ}\text{C}$; Loading $600\ \Omega$

Parameter	Sym.	Condition	MIN	TYP	MAX	Unit
RING amplitude	V _{TR}	5 REN load; sine wave; R _{LOOP} = 160 Ohm; V _{BAT} = -75 V	44	45	---	V _{RMS}
Loop closure / Ground start threshold accuracy	I _{lt}	I _{lt} = 11.43 mA	---	---	+/-20	%
RING trip threshold accuracy	I _{rt}	I _{rt} = 40.64 mA	---	---	+/-20	%
Trapezoidal RING crest factor accuracy		Crest factor = 1.3	---	---	+/-0.05	
Sinusoidal RING crest factor	R _{cf}		1.35	---	1.45	
Ringing frequency accuracy		F = 20 Hz	---	---	+/-1	%
Ringing cadence accuracy		Accuracy of on/off time	---	---	+/-50	ms
DC Loop Current Accuracy		ILIM = 20 mA, R _{LOAD} = 500 ohm		---	+/-20	%
DC Open Circuit Voltage Accuracy		Active Mode; V _{OH} = 48 V, V _{TIP} - V _{RING}		---	+/-4	V
Power alarm threshold accuracy		Power Threshold = 300 mW	---	---	+/-25	%

11.9. ANALOG DISTORTION AND NOISE PARAMETERS

$V_{DD}=3.13\text{ V} - 3.47\text{ V}$; $V_{SS}=0\text{ V}$; $T_A=-40^{\circ}\text{C}$ to $+85^{\circ}\text{C}$; Loading $600\ \Omega$

PARAMETER	SYM.	CONDITION	TRANSMIT (A/D)			RECEIVE (D/A)			UNIT
			MIN	TYP	MAX	MIN	TYP	MAX	
Total Distortion vs. Level Tone u-Law	D_{LTu}	1020 Hz, C-Message Weighted	See Figure			See Figure			
Total Distortion vs. Level Tone, A-Law	D_{LTA}	1020 Hz, Psophometric Weighting							
Audio Tone Generator Signal-to-Distortion Ratio	D_{LTT}	0 dBm0, Active OFF-HOOK and OHT, ideal impedance matching	45	---	---	45	---	---	dB
Spurious Out-Of-Band (300 Hz to 3400 Hz @ 0dBm0)	D_{SPO}	4600 Hz to 7600 Hz 7600 Hz to 8400 Hz 8400 Hz to 100000 Hz	NA	NA	NA	---	-70 -70 -65	-30 -40 -30	dB
Spurious In-Band (700 Hz to 1100 Hz @ 0dBm0)	D_{SPI}	300 to 3200 Hz	---	---	-47	---	---	-47	dB
Intermodulation Distortion (300 Hz to 3400 Hz -4 to -21 dBm0)	D_{IM}	Two tones	---	---	-45	---	---	-45	dB
Idle Channel Noise	N_{IDL}	u-Law; C-message A-Law; Psophometric 16-bit Linear	---	13 -74 ---	18 -69	---	1 -90 ---	14 -76	dBrnc0 dBm0p
Power Supply Rejection	$PSRR_A$	V_{DDA} ; DC to 3.4 kHz	40	---	---	40	---	---	dB
Power Supply Rejection	$PSRR_B$	V_{BAT} ; DC to 3.4 kHz	40	---	---	40	---	---	dB

12. FUNCTIONAL DESCRIPTION

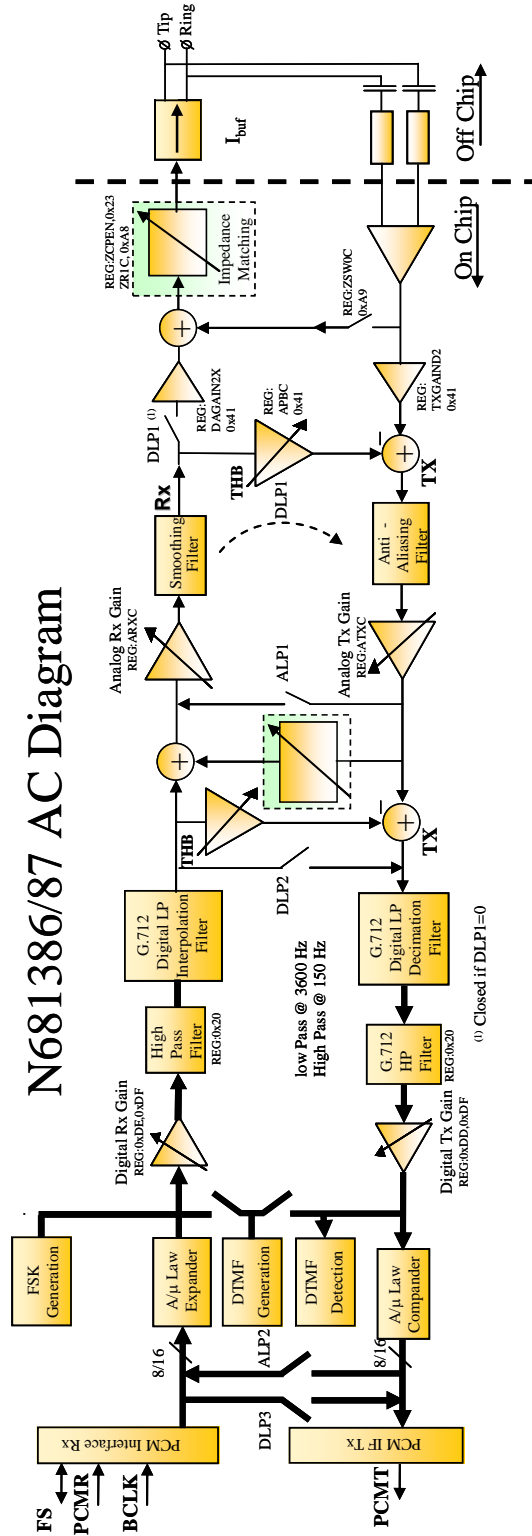

Figure 4: AC signal Path

12.1. BORSCHT FUNCTIONALITY

The N681386/87 connects to the TIP and RING (POTS - Plain Old Telephone Service) interface and performs the so-called BORSCHT and AC transmission functions. Following are the BORSCHT functions:

- ◆ **B**attery Feed
- ◆ **O**ver-Voltage Protection
- ◆ **R**inging (Balanced / Unbalanced)
- ◆ **S**upervision (Signaling)
- ◆ **C**oding
- ◆ **H**ybrid (2 / 4-wire conversion)
- ◆ **T**esting

12.1.1. BATTERY FEED

The N681386/87, has two DC feed regions; a constant voltage region and a constant current region. As illustrated in Figure 4 the current limit I_{LIM} determines the constant current region. The ON-HOOK voltage, V_{OH} , determines the constant voltage region. The device has an inherent output resistance of typically 50Ω in non-ringing states. The Ground Margin Voltage, V_{GM} , determines the offset of the most positive terminal (TIP in Forward polarity state and RING in Reverse polarity state) with respect to ground. I_{LIM} , V_{OH} , and V_{GM} are programmable as shown in Table 2.

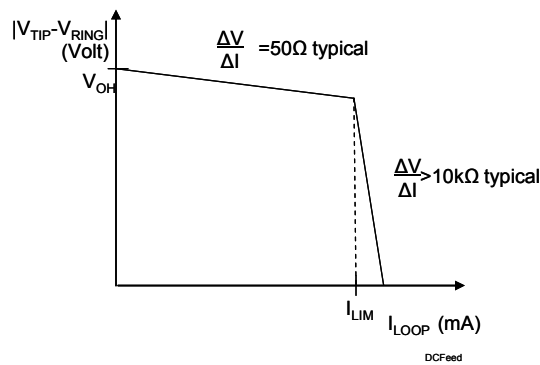

Figure 5: DC Feed Regions

Register	Address	Parameter	Programmable Range	Step Size	Default Value	Unit
LCL	0x45	I_{LIM}	20 – 41	3	20	mA
OHV	0x4C	V_{OH}	0 to -93.5	1.484	-47.488	V
GMV	0x4D	V_{GM}	0 to -93.5	1.484	-2.968	V

Table 3: Programmable Ranges for DC Line Feed

The control circuit for TIP or RING is illustrated in Figure 5 and utilizes a three transistor discrete Linefeed circuit. Transistors Q1 and Q2 drive the voltages on the subscriber loop while transistor Q3 provides additional isolation. The Line Driver DC feedback loop is completed via DC isolation resistors R_{VBAT} and R_{VE} to the chip. TIP and RING signals are derived from the common mode and differential mode signal block. This information is, in turn, used to exercise control over the external transistors. Voice band signals are passed over a decoupling capacitor in the AC feedback loop.

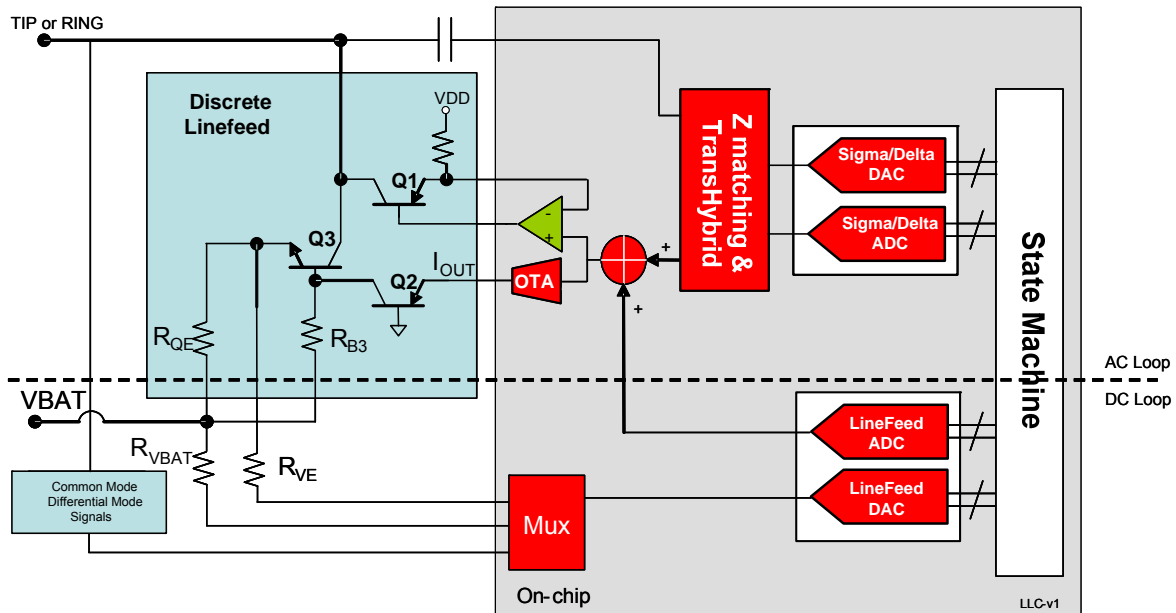

Figure 6: Line Loop Control

Control and monitoring of these transistors is done both individually and in groups. For example, TIP and RING Linefeed circuits each have a Q1 transistor. Both share the same register to set their Power Alarm Threshold values. But each TIP and RING transistor has a separate Power Alarm Interrupt bit in the interrupt register. The control circuit for TIP and RING when N681622 is utilized follows the same general principles.

12.1.1.1. LINEFEED STATES OF OPERATION

The N681386/87 can operate in eleven states, as shown below.

State	LS Settings				Description
	MSB		LSB		
Open	0	0	0	0	TIP and RING tri-state
Forward Active	0	0	0	1	$V_{TIP} > V_{RING}$
Forward ON-HOOK Transmission	0	0	1	0	$V_{TIP} > V_{RING}$; audio signal paths powered on
TIP Open	0	0	1	1	TIP tri-stated, RING active; used for ground start
Ringing	0	1	0	0	Ringing waveform applied to TIP and RING
Reverse Active	0	1	0	1	$V_{RING} > V_{TIP}$
Reverse ON-HOOK Transmission	0	1	1	0	$V_{RING} > V_{TIP}$; audio signal paths powered on
RING Open	0	1	1	1	RING tri-stated, TIP active
Forward Idle	1	0	0	1	$V_{TIP} > V_{RING}$
Reverse Idle	1	1	0	1	$V_{RING} > V_{TIP}$
Calibration	1	1	1	0	$V_{TIP} = V_{RING} \sim V_{bat} + 2$

Table 4: Linefeed States

12.1.1.1.1. OPEN STATE

Current to the external linefeed circuitry is shut off, effectively making TIP and RING tri-stated and it can also be used for fault condition detection. DC output impedance is 150K ohm.

12.1.1.1.2. ACTIVE, IDLE AND ON-HOOK TRANSMISSION STATES

- ◆ Active, Idle and ON-HOOK Transmission states all have both Forward and Reverse incarnations
- ◆ In Forward state TIP is the more positive lead
- ◆ In Reverse state RING is the more positive lead
- ◆ In Idle states the external linefeed circuitry is ON but the audio signal paths are not powered up.
- ◆ In both Active states the external linefeed circuitry is ON and the audio signal paths are powered up.
- ◆ In both ON-HOOK Transmission states audio signal paths are powered up to allow ON-HOOK transmission.

The Forward and Reverse incarnations of the Active, Idle and ON-HOOK Transmission states are determined solely by setting the LS register. For automatic transitions Forward and Reverse incarnations are determined by the V_{OH} polarity in OHV:SB[6] address location (0x4C).

12.1.1.1.3. TIP OPEN STATE

- ◆ All control currents to the external circuitry associated with TIP are shut off.
- ◆ Linefeed is provided to RING.

12.1.1.1.4. RING OPEN STATE

- ◆ All control currents to the external circuitry associated with RING are shut off and keeps TIP active.

12.1.1.1.5. RINGING STATE

- ◆ Drives the ringing waveforms onto the loop

12.1.1.1.6. CALIBRATION STATE

Calibration state is used to compensate or correct for external component imperfections. It should be performed following the system power up. This state is enabled by setting LS:LS[3:0] address (0x44) to '1110'. The line should be on-hook during calibration. RING or TIP must not be connected to ground during the calibration. All automatic linefeed transitions should be disabled when performing calibration. After calibration is completed, the Linefeed state should be reset to a normal operating state and the automatic Linefeed transitions can be enabled again. Calibration state is not applicable to SLFC. For a more detailed explanation, please refer to the Calibration Application note.

Please note that Calibration state is not applicable to Subscriber Line Feed Circuit (SLFC).

12.1.1.2. OPERATION MODES

The N681386/87 can operate under two battery supply operation modes. The modes are selected with a pin XBAT as illustrated below.

Operation Mode	XBAT Pin	Per Channel DC/DC	VBAT Switch [DCN/DCP Line state dependent Control]
On-Chip DC/DC Controller	0V	On	Off
External Battery Supplies	3.3V	Off	On

Table 5: Operation Modes

12.1.1.3. AUTOMATIC TRANSITIONS

In addition, some automatic state transitions may also be enabled:

12.1.1.3.1. POWER ALARM AUTOMATIC REACT

- ◆ Setting LAMC:PAA[2] address (0x43) bit will make the channel automatically enter the Open state upon the occurrence of a power alarm.

12.1.1.3.2. SETTING RING AUTOMATIC

- ◆ Setting LAMC:RGA[1] address (0x43) bit makes the channel automatically enter the Active state from the Ringing State upon RING Trip Detect

12.1.1.3.3. SETTING LOOP CLOSURE DETECT AUTOMATIC REACT

Setting LAMC:LCDA[0] address (0x43) bit makes the channel automatically enter the Active state from the ON-HOOK Transmission, Idle, TIP Open, and RING Open states upon Loop Closure Detect. Furthermore, the channel will transition from Active to Idle state if the Loop Closure Detect circuitry indicates a loop closure is no longer present, and back to Active state upon a reoccurrence of Loop Closure Detect.

When the above automatic transitions do occur, LS:LS[3:0] address (0x44) will be updated automatically to reflect the newly entered state. In all cases the shadow linefeed status bits, LS:SLS[3:0] address (0x44) reflect the actual linefeed status. This includes switching between 'Ringing' during the ring burst and 'ON-HOOK Transmission' during the cadence. This RING/cadence transition is not considered an automatic transition and LS:LS[3:0] address (0x44) will continue to reflect Ringing state. The following example state diagram illustrates LS:SLS[3:0] address (0x44) states including automatic transitions, RING/Cadence transition and several possible transitions solely governed by software.

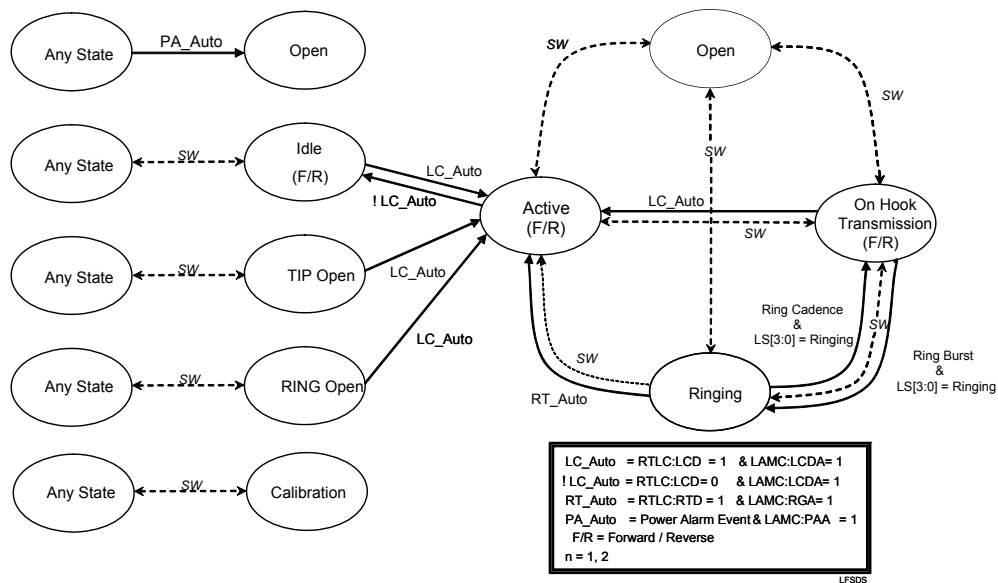

Figure 7: Example State Diagram

Register	Bit(s)	Address	Parameter	Description / Range
LS	LS[3:0]	0x44	Programmed Linefeed Status	Eleven states
	SLS[7:4]	0x44	Shadow Linefeed Status	Reflects actual state
LAMC	PAA[2]	0x43	Power Alarm Automatic React	Enable/Disable
	RGA[1]	0x43	RING Automatic	Enable/Disable
	LCDA[0]	0x43	Loop Closure Detect Automatic React	Enable/Disable

Table 6: Associated Registers for Linefeed Control

The device continuously monitors voltages on the line driver, driving them to target voltages appropriate to the actual linefeed state as summarized below.

Linefeed State	TIP Target	RING Target
Open	High Z	High Z
Forward Active	$V_{TIP} > V_{RING}$	
Forward ON-HOOK Transmission	$V_{TIP} > V_{RING}$	
TIP Open	High Z	Active
Ringing	RING Signal	RING Signal
Reverse Active	$V_{TIP} < V_{RING}$	
Reverse ON-HOOK Transmission	$V_{TIP} < V_{RING}$	
RING Open	Active	High Z
Forward Idle	$V_{TIP} > V_{RING}$	
Reverse Idle	$V_{TIP} < V_{RING}$	

Table 7: TIP and RING Voltage Targets

The device monitors the currents in the external transistors and makes these values available in registers. These registers and the internal A/D are updated at a rate of 800 Hz or every 1.25 msec. Other useful voltages and currents are calculated internally and made available in registers.

Register	Bits(s)	Address	Parameter	Description / Range
BATV	VB[7:0]	0x80	Battery Voltage	0V to -94.6V in 0.371V steps
SCM	SCM[11:0]	0x92	Common Mode Voltage	+93.5V to -93.5V in 0.023 V steps
QT3V	QT3V[7:0]	0x83	Transistor QT3 Emitter Voltage	0V to -94.6V in 0.371V steps
QR3V	QR3V[7:0]	0x84	Transistor QR3 Emitter Voltage	0V to -94.6V in 0.371V steps
QT3I	QT3I[11:0]	0x85	Transistor QT3 Current	0A to 78.54 mA in 19.2 μ A steps
QR3I	QR3I[11:0]	0x86	Transistor QR3 Current	0A to 78.54 mA in 19.2 μ A steps

Table 8: Registers Associated with Line Monitoring – Measured

Register	Bit(s)	Address	Parameter	Description / Range
LPV	VLP[11:0]	0x8D	Loop Voltage	+93.5V to -93.5V in 0.023 V steps
QT1I	QT1I[11:0]	0x87	Transistor QT1 Current	0A to 78.54 mA in 19.2 μ A steps
QT2I	QT2I[11:0]	0x88	Transistor QT2 Current	0A to 9.95 mA in 2.5 μ A steps
QR1I	QR1I[11:0]	0x89	Transistor QR1 Current	0A to 78.54 mA in 19.2 μ A steps
QR2I	QR2I[11:0]	0x8A	Transistor QR2 Current	0A to 9.95 mA in 2.5 μ A steps
LGI	ILG[11:0]	0x8C	Longitudinal Current	+77.62 mA to -77.62 mA in 19uA
TIPI	ITLP[11:0]	0x8E	TIP Current	+77.62 mA to -77.62 mA in 19uA
RINGI	IRLP[11:0]	0x8F	RING Current	+77.62 mA to -77.62 mA in 19uA
LPI	ILP[11:0]	0x90	Loop Current	+77.62 mA to -77.62 mA in 19uA

Table 9: Registers Associated with Line Monitoring – Calculated

In addition the following loop voltages and currents are derived from the above measurements and reported separately.

12.1.1.4. POLARITY REVERSAL

The Linefeed states which have Forward or Reverse incarnation (Active, Idle and ON-HOOK Transmission states) can have the polarity reversed two different ways. In addition, the line (TIP or RING) which is at VOH can be collapsed towards ground by using the wink function.

- ◆ Hard polarity reversal
- ◆ Soft polarity reversal

12.1.1.4.1. HARD POLARITY REVERSAL

Hard polarity is achieved by abruptly reversing the voltage between TIP and RING without any ramp-rate control. This is achieved by simply changing the linefeed register from Forward to Reverse incarnation or vice versa. A Hard polarity reversal will be performed provided that soft polarity reversal is not enabled APG:PREN[6] address (0x40) bit to 0. The sign bit (OHV:SB[6]) is used to determine the polarity of the line when going from Idle to Active States. If the new polarity is to be retained in future Idle to Active transitions, it is recommended that this bit be also changed appropriately when polarity is reversed.

12.1.1.4.2. SOFT POLARITY REVERSAL

Soft polarity is achieved by reversing the voltage between TIP and RING with ramp-rate control. Soft polarity reversal is enabled by setting APG:PREN[6] = "1" address (0x40). The ramp rate at which the reversal will occur is selected in APG:RAMP[8] address (0x40). The Ramp is triggered by toggling WINK bit APG:PREN[6] = "1" address (0x40). Soft polarity reversal can be used from Forward Active to Reverse Active or vice versa. The table below illustrates the sequence of events for a Forward to Reverse soft polarity reversal. For Reverse to Forward Polarity Reversal step 2 would involve TIP and step 4 would involve RING.

Step(s)	Register Name	Bit(s)	Bit State	Step Description
1	APG	PRE[6]	1	Enables soft polarity reversal
2	APG	VOHZ[5]	1	Wink line (RING towards 0V)
3	Use Line state register to reverse the line from Forward to Reverse			
4	APG	VOHZ[5]	0	Un-wink line (TIP side towards VOH)
5	APG	PRE[6]	0	Disable soft polarity reversal

Note that the negative going ramp rate can be limited by the settling speed of the DCDC converter. Setting the minimum on time (0x57) to 0x0B before the ramp and back to the initialization value after the ramp will prevent this

Addr	Name	D7	D6	D5	D4	D3	D2	D1	D0	Default
0x40	APG	RAMP	PREN	VOHZ	RES	ARX[1:0]		ATX[1:0]		0x00

The sign bit (OHV:SB[6]) is used to determine the polarity of the line during an automatic transition into idle, Active, and On-Hook transition states. If the new polarity is to be retained in future automatic transitions, it is recommended that OHV:SB[6] be also changed appropriately when polarity is reversed.

The ramp rate for steps 2 and 4 above is determined by the Ramp Rate bit APG:RAMP[7].

12.1.1.5. WINK FUNCTION POLARITY REVERSAL

A Wink function is used for the 'message waiting' lamp in telephone sets. For this function to take place no Linefeed state change is necessary. The Wink function is a variation of Soft Polarity Reversal but without any Linefeed state change. In this case Soft Polarity reversal is enabled as before (APG:PREN[6] address (0x40) bit to "1", with APG:RAMP[7] address (0x40) selecting the ramp rate). Now the OHV:VOHZ[5] address (0x4C) bit can be used to directly ramp the RING line towards 0V or back to V_{RING} . For example, in Forward Idle mode V_{TIP} is at V_{GM} and V_{RING} is $V_{GM}+V_{OH}$. If VOHZ bit is set to "1" the Ring Voltage will ramp towards 0V. If the bit is toggled it will eventually return to the nominal V_{RING} setting. The user has full control of the Wink function cadence.

Register	Bit(s)	Address	Parameter	Programmable Range
APG	VOHZ[5]	0x40	Wink Function (Smooth transition to $V_{OH}=0V$)	0 = Return to previous V_{OH} 1 = Ramp to 0V
APG	PRE[6]	0x40	Soft Polarity Reversal Enable	0 = Disabled 1 = Enabled
APG	RAMP[7]	0x40	Soft Polarity Reversal Ramp Rate	0 = 1.5 V/125 μ s 1 = 3.0 V/125 μ s
LS	LS[3:0]	0x44	Linefeed Status	
OHV	SB[6]	0x4C	Polarity Reversal Status (Sign)	0 = Forward 1 = Reverse

Table 10: Registers for Polarity Reversal

12.1.2. OVER-VOLTAGE PROTECTION

It is a common requirement for electronic circuits to have to withstand some degree of over-voltage and/or reverse voltage on the power-supply lines. Integrated circuits are designed to operate from a nominal 3.3V power supply. Some kind of protection circuit is therefore needed to prevent voltages greater than the maximum allowable from being applied to the IC pins. The N681386/87 device needs to be protected from surges and AC power shorts. This should be implemented using external components and a variety of commercial approaches are typically employed. However, N681386/87 device has on-chip voltage and line monitoring capabilities which allow the system to report line faults, crossovers, and other line conditions in order to facilitate remote service. It also has sense inputs can be configured such that blown fuse can be detected. The on-chip DC/DC controller is equipped with three protection shutdown mechanisms. It detects

- a) DCDC output voltage (VBAT) 10% above full scale or
- b) DCDC supply voltage (VDDC) too low or
- c) DCDC supply current (I_{VDDC}) too high;

A counter is tracking the three cases of DC/DC power alarm. The counter will automatically reset upon being read, allowing the user to monitor the number of power alarms within a specific time period. This register is a read ONLY register resets upon a read command.

Register	Bit(s)	Address	Parameter	Programmable Range
APG	PALT[7:0]	0x9F	Power Alarm Counter	Increment on every rising edge of LOW VDC or HIGH IDC; clip at 255;

Table 11: PWM DC/DC Power Alarm Counter

12.1.2.1. THERMAL OVERLOAD

In addition to voltage and current monitoring described in section 6.1.1.1 “Linefeed States of Operation”, N681386/87 continuously monitors the power dissipation of each external transistor in the Linefeed circuitry. After Low Pass Filtering, the power dissipation is compared against thresholds which are listed in Table 10. The threshold and the Low Pass Filter pole are both programmable and should be set according to the characteristics of the individual transistor as follows. The Low Pass Filter pole for QT1 and QR1 is given by the equation:

$$Q1C[12:0] = \left(1 - \frac{1}{800 \times T_{TC}} \right) \times 2^{13}$$

Where T_{TC} is the thermal time constant of the external transistor. The threshold should be programmed according to the maximum power dissipation of the external transistor. If the threshold is exceeded a power alarm event is deemed to have occurred. An associated interrupt may be enabled. An automatic state transition into Open state may be enabled by setting Power Alarm Automatic React (LAMC:PAA[2]) address (0x43)).

Register	Bit(s)	Address	Parameter	Description / Range
PALPQ1 PALPQH1 PALPQH2	Q1C[7:0] Q1C[11:8] Q1C[12]	0xA1 0xA3 0xA4	PA Low Pass Filter Pole for QT1 and QR1	See Register Description
PALPQ2 PALPQH1 PALPQH2	Q2C[7:0] Q2C[11:8] Q2C[12]	0xA0 0xA3 0xA4	PA Low Pass Filter Pole for QT2 and QR2	See Register Description
PALPQ3 PALPQH2 PALPQH2	Q2C[7:0] Q3C[11:8] Q3C[12]	0xA2 0xA3 0xA4	PA Low Pass Filter Pole for QT3 and QR3	See Register Description
PATHQ1	Q1TH[7:0]	0xA6	PA Threshold for QT1 and QR1	0 to 7.7 W in 30.4 mW steps
PATHQ2	Q2TH[7:0]	0xA5	PA Threshold for QT2 and QR2	0 to 0.97 W in 3.8 mW steps
PATHQ3	Q3TH[7:0]	0xA7	PA Threshold for QT3 and QR3	0 to 7.7 W in 30.4 mW steps
INT1		0x26	Power Alarm Interrupt	Enable/Disable
IE1		0x27	Power Alarm Interrupt Enable	Enable/Disable
LAMC	PAA[2]	0x43	Power Alarm Automatic React	Enable/Disable

Table 12: Registers Associated with Thermal Overload

12.1.2.2. TEMPERATURE MONITOR

The device contains an on-chip temperature sensor that senses the temperature inside the package. The sensor is read through TEMP:TS[7:0] register (0x99) which is **READ ONLY** register. The temperature T in °C is given by the following equation.

$$T = TS[7:0] - 67$$

For example TEMP:TS[7:0] = 0x23, (35 decimal) indicates a temperature T=-32°C and TEMP:TS[7:0]=0xCD (205 decimal) indicates T=138°C. Similarly threshold temperatures T_{TH} can be set in register THAT:THAT[7:0] address (0xAA). The T_{TH} is calculated by the following equation.

$$T_{TH} = TATH[7:0] - 67$$

By enabling the temperature sensor interrupt in IE3:TMPE[0] address (0x2B), an interrupt will be generated if the temperature reaches this threshold. This facilitates control of the temperature should the device get close to the junction temperature. Note that there is no filtering associated with this temperature alarm since the package has an intrinsic thermal time constant. It is recommended that the temperature alarm threshold be set to 125°C. The actual, T_{INT}, internal temperature can be estimated by the following equation.

$$T_{INT} = T_A + \left(R_J \times P \right)$$

T_A – Ambient Temperature, R_J – Thermal Resistance, P – Power Dissipation

For example, the maximum power dissipation for the QFN device is 0.7 W. The thermal resistance of the 48-pin QFN package is 27.1°C/W. So at T_A=85°C, the estimated internal temperature would be:

$$T_{INT} = 85 + 27.1 * 0.7 = 104^{\circ}\text{C}$$

12.1.3. RINGING

There is a built-in RING generator that can generate balanced sinusoidal or trapezoidal ringing without the need for external components. Both trapezoidal and sine wave ringing signals can be generated. The Frequency, Amplitude, DC offset and ringing cadence of the ringing signal are programmable. In the case of trapezoidal waveforms the crest factor is also programmable. The choice of sinusoidal or trapezoidal will depend on requirements of the end user; sinusoids are required in many parts of the world to minimize cross talk between the many tip/ring pairs in a typical wiring bundle from the central office, whereas a trapezoid will deliver more power to the phone due to its low crest factor. As Ringing utilizes the Tone Generation block, we will first examine this function.

12.1.3.1. TONE GENERATION

There are two tone generators Oscillator1 (OS1), and Oscillator2 (OS2). These can be used to generate signals such as dial tone, busy tone, and various test tones which can be sent either on the transmit or receive paths. Each tone generator has a similar architecture and contains a two-pole oscillator circuit with a sample rate of 8 kHz.

Register	Bit(s)	Address	Parameter	Description / Range
OS1ICL OS1ICH	O1IC[15:0]	0xC2 0xC3	Oscillator 1 Amplitude Coefficient	Sets Amplitude
OS1CL OS1CH	O1C[15:0]	0xC6 0xC7	Oscillator 1 Frequency Coefficient	Sets Frequency
OS1ATL OS1ATH	O1ON[15:0]	0xCA 0xCB	Oscillator 1 Active Timer	0 to 8 sec
OS1ITL OS1ITH	O1OFF[15:0]	0xCE 0xCF	Oscillator 1 Inactive Timer	0 to 8 sec
RMPC	TOR[3]	0xC1	Tone Route	Towards D/A or A/D
OSN	O1E[0] O2E[1]	0xC0 0xC0	Oscillator Control	Control
IE2	O1AE[0] O1IE[1] O2AE[2] O2IE[3]	0x29 0x29 0x29 0x29	Interrupt Mask / Enable	Control
INTV IINT2		0x24 0x28	Interrupt Vector Low Register Interrupt Status	Status

Table 13: Associated Registers for Oscillator Control (Oscillator 1 Example)

For a desired frequency f_t the oscillator coefficient for Oscillator m, $O_mC[15:0]$, can be calculated with the following equations. The following equations can be used for both Narrowband and Wideband. The resulting hexadecimal coefficients are inputs to registers $OSmCH$ and $OSmCL$.

$$OIC [15:0] = \cos \left[\frac{2 * \pi * f_t}{16 \text{ kHz}} \right] * 2^{15} \qquad O2C [17:0] = \cos \left[\frac{2 * \pi * f_t}{16 \text{ kHz}} \right] * 2^{17}$$

The initial condition for Oscillator m, OSmICL[15:0], can be calculated using the following equation. The following equations can be used for both Narrowband and Wideband.

$$O_mIC [15:0] = A * \sin \left[\frac{2 * \pi * f_t}{16 \text{ kHz}} \right] * 2^{15} \quad (m: 1, 2)$$

“A” is calculated as the ratio of desired peak amplitude, A_{PK} , with a peak D/A output of 1.5779 V_{PK} . A_{PK} cannot exceed 1.2 V_{PK} . The resulting hexadecimal coefficient is input to registers OSmICH and OSmICL.

$$A = \frac{A_{PK}}{1.5779}$$

Frequency (Hz)	O1C[15:0]	A_{PK} (Volts)	O1IC[15:0]
697	0x7B3C	0.31	0x06C5
770	0x7A37	0.31	0x0775
852	0x78E7	0.31	0x0839
941	0x775C	0.31	0x090B
1209	0x71D8	0.55	0x145B
1336	0x6EC9	0.55	0x164E
1477	0x6B11	0.55	0x1868
1633	0x6692	0.55	0x1AA4

Frequency (Hz)	O2C[17:0]	A_{PK} (Volts)	O2IC[15:0]
697	1ECF0	0.31	0x06C5
770	1E8C5	0.31	0x0775
852	1E39B	0.31	0x0839
941	1DD70	0.31	0x090B
1209	1C75E	0.55	0x145B
1336	1BB22	0.55	0x164E
1477	1AC43	0.55	0x1868
1633	19A48	0.55	0x1AA4

Table 14: Example Register settings for Oscillator m

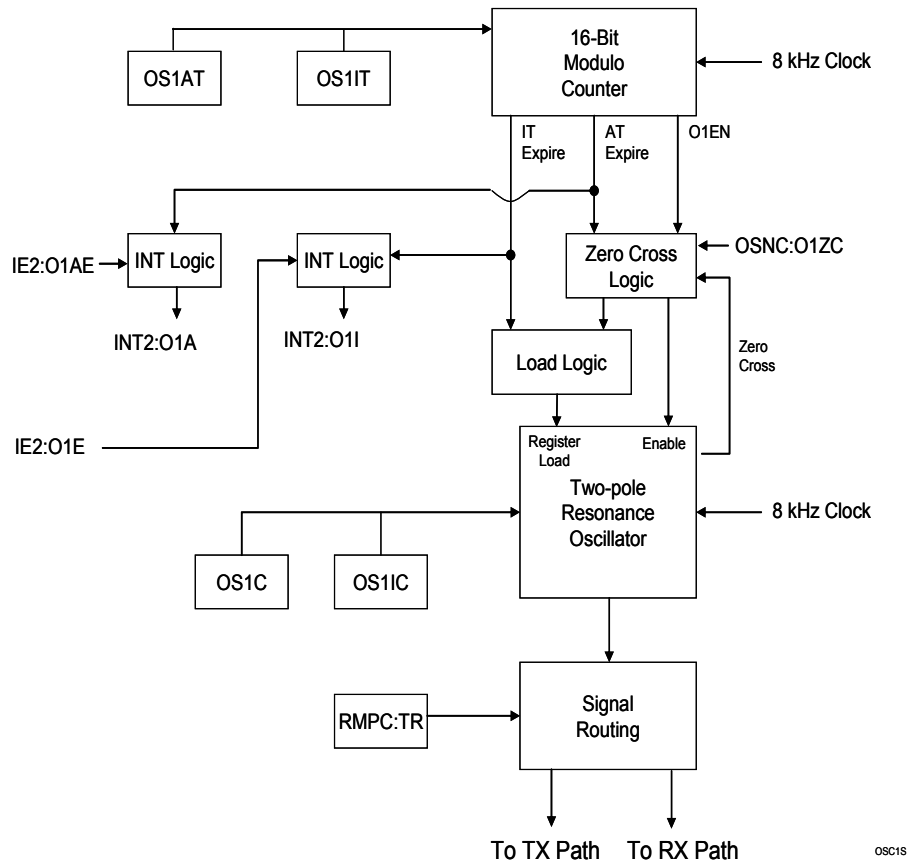

Figure 8: Block Diagram Oscillator 1

Each tone generator contains two timers, one for setting the active period and the other for the inactive period. Each period can be programmed between 0 seconds (timer disabled) to 8 seconds in 125µs increments. In addition, interrupts can be enabled on the expiration of either timer. The device has programmable cadence where the signal is generated during the active period and suspended during the inactive period.

One-shot control of the oscillation can be achieved by controlling OSN:O1E[0] and OSN:O2E[1] address (0xC0) together with the active timer and the interrupt for durations up to 8 seconds. For longer durations or for direct software control of the oscillation, enabling the active timer by setting it to any non-zero value while simultaneously disabling the inactive timer completely will put the oscillator under direct control of the OSN:OmE bit. Zero crossing detect can be enabled by setting the OSN:OmZC bit for the corresponding tone generator. Setting this bit will ensure that each oscillator pulse will end without a DC component as illustrated below.

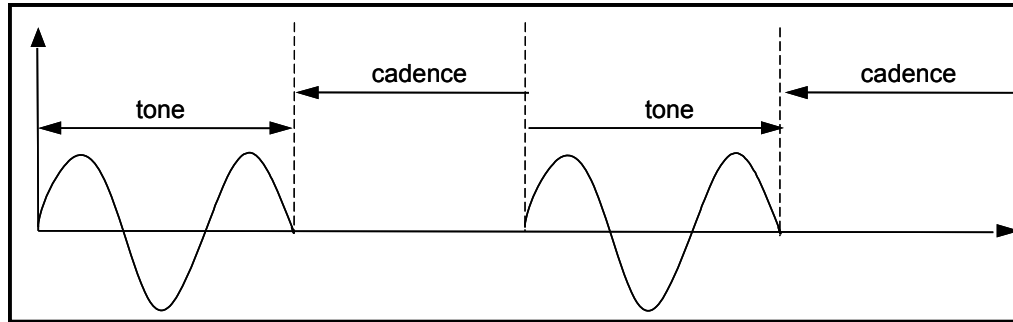

Figure 9: Zero Crossing for Tone Generation

Oscillator 2 is also specifically used to generate the Ringing signal and is unavailable for other functions during ringing. FSK generation does not utilize either one of the tone generation oscillators.

12.1.3.2. RING SIGNAL GENERATION

The N681386/87 supports balanced and unbalanced Ringing up to 90 VPK (5 REN up to 4 kft, 4REN up to 4.5 kft, 3 REN up to 8 kft). Oscillator 2 from the Tone Generation block is used to generate the Ringing waveform. However, programming the waveform, sinusoidal or trapezoidal, involves some slight modifications to the procedures described for Tone Generation. The active and inactive timers of oscillator 2 can be programmed between 0 seconds (timer disabled) and 8 secs in 125us increments. A Ring phase delay can also be programmed in the OS2RPD:O2RPD[7:0] address (0xAD).

All other oscillator operations are standard and follow the description in the tone generation section. Interrupts can be enabled on the expiration of either timer, so that, for instance, Caller ID can be inserted between tones. Cadence is activated when a non-zero value is programmed into both the active and inactive timers. In this case, these timers effectively govern the transitions in and out of the Ringing state as described in Linefeed States of Operation in Section 6.1.1.1.

When the Ring Automatic bit LAMC:RGA[1] address (0x43) is set, the oscillator is automatically enabled when the Ringing state is entered and disabled when exited. If the Ring Automatic bit is enabled the transition from Ringing to Active state (Forward or Reverse) occurs automatically upon Ring Trip Detect. The oscillator enable and ring enable bits are automatically updated accordingly OSN:O2E[1] address (0xC0) and RMPC:R1EN[5] address (0xC1).

One-shot control of the oscillation can be achieved by controlling OSN:O2E[1] address (0xC0) together with the active timer and the active timer interrupt for durations up to 8 seconds. For longer durations or for direct software control of the oscillation, enabling the active timer by setting it to any non-zero value, while simultaneously disabling the inactive timer completely, will put the oscillator under complete direct control of the OSN:O2E[1] address (0xC0) bit. Zero crossing detect can be enabled by setting the OSN:O2ZC[3] address (0xC0). Setting this bit will ensure that

the RING signal will end without a DC component. It is recommended that settings be reprogrammed only when the oscillator is disabled.

Register Name	Register Name	Address	Parameter	Description / Range
RMPC	TRAP[7]	0xC1	Ringing Waveform	Sine/Trapezoid
OS2CL OS2CH	O2C[17:0]	0xC8 0xC9 0xDC	Ringing Frequency	15 to 100 Hz for Sine Trapezoid Ramp Slope
OS2ICL OS2ICH	O2IC[15:0]	0xC4 0xC5	Ringing Amplitude	0 to 93.5 V Trapezoid tRISE / tPEAK
OS2RPD	OS2RPD[7:0]	0xAD	Ringing Phase Delay	0 to 32 ms
OSN	O2E[1]	0xC0	Ringing Oscillator Enable	Enable/Disable
OS2ATL OS2ATH	O2ON[15:0]	0xCC 0xCD	Ringing Oscillator Active Timer	0V to 8 seconds
OS2ITL OS2ITH	O2OFF[15:0]	0xD0 0xD1	Ringing Oscillator Inactive Timer	0V to 8 seconds
OSN	O2ZC[5]	0xC0	Ringing Oscillator Zero Cross Enable	Enable/Disable
LS	LS[3:0]	0x44	Linefeed Status Control (Initiates Ringing State)	Ringing State = 0100b
VBHV	VBATH[5:0]	0x4E	VBATH High Battery Voltage /2	0V to -93.5V in 1.484V steps
VCMR	VCMR[5:0]	0x42	VCMR Common Ringing Bias Adjust During Ringing	0V to -93.5V in 1.484V steps
ROFFS	ROS[5:0]	0xDC	Ringing DC voltage offset	0V to +47.488 V in 1.484V steps
IE2		0x29	Interrupt Enable	Controls
INTV INT2		0x24 0x28	Interrupt	Status

Table 15: Registers for RING Generation

12.1.3.2.1. SINUSOIDAL RINGING

Sinusoidal Ringing is selected by setting RMPC:TRAP[7] address (0xC1) to LOW. For a desired frequency f_R is calculated and programmed as before (see section Tone Generation). The oscillator initial condition for oscillator 2 is set in register O2IC[15:0] address (0xC4 – 0xC5) according to the following equation.

Description	Equation
Desired frequency f_R <i>The resulting hexadecimal coefficient is input to registers OS2CH and OS2C and ROFFS</i>	$O2C [17:0] = \text{COS} \left[\frac{2 * \pi * f_R}{8 \text{ kHz}} \right] * 2^{17}$
Oscillator initial condition for oscillator 2 <i>The resulting hexadecimal coefficient is input to registers OS2ICH and OS2ICL</i>	$O2IC [15:0] = A * \sin \left[\frac{2 * \pi * f_R}{8 \text{ kHz}} \right] * 2^{15}$
A is calculated from the desired peak amplitude, A_{PK} , in volts	$A = \frac{A_{PK}}{96}$

Note that A is calculated differently for Tone Generation. Finally the precise phase position where the sinusoidal ringing signal begins transmitting can be controlled by programming a transmission or phase delay of up to 31.8 ms into OS2RPD:O2RPD[7:0] address (0xAD). If the zero-crossing feature is enabled signal transmission will end at the equivalent phase position.

Target Frequency (Hz)	Frequency (Hz)	O2C[17:0]
10	11.12	1FFF B
11	11.12	1FFF B
12	12.18	1FFF A
13	13.15	1FFF 9
14	14.07	1FFF 8
15	15.73	1FFF 6
16	16.49	1FFF 5
17	17.22	1FFF 4
18	18.60	1FFF 2
19	19.27	1FFF 1
20	20.51	1FFE F
25	25.37	1FFE 6
50	50.26	1FF 9A

Table 16: Example Ringer Register settings

12.1.3.2.2. TRAPEZOIDAL RINGING

Trapezoidal Ringing is selected by writing RMPC:TRAP[7] = 1 address (0xC1). Three parameters are required to specify a Trapezoidal RING Signal and they as follows:

- Desired frequency f_t (period T)
- Desired amplitude A_{PK}
- Crest factor, CF

Three values are programmed across O2C[17:0] and O2IC[15:0] to describe the waveform.

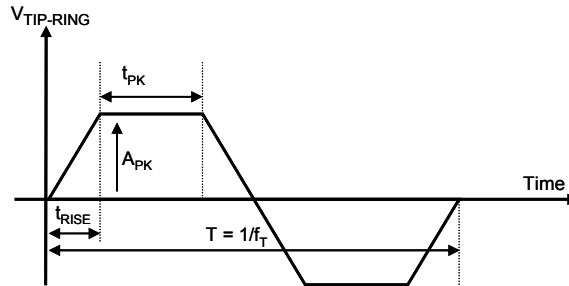

Figure 10: Trapezoidal Ringing

TR_v1

Description	Equation
Calculated rise time (t_{RISE})	$t_{RISE} = 0.375 * T * \left(1 - \left(\frac{1}{CF^2} \right) \right)$
The rise time, expressed as an integer number of periods of 8 kHz, OS2ICL <i>The resulting hexadecimal coefficient is input to registers OS2ICL</i>	$O2IC[7:0] = t_{RISE} * 8 \text{ kHz}$
Calculated peak time (t_{PK})	$t_{PK} = (0.5 * T) - (2 * t_{RISE})$
The peak time, expressed as an integer number of periods of 8 kHz, OS2ICH <i>The resulting hexadecimal coefficient is input to registers OS2ICH</i>	$O2IC[15:8] = t_{PK} * 8 \text{ kHz}$
Calculated ramp rate is specified in O2C[15:0] <i>Oscillator 2 has 18-bit register. The resulting hexadecimal coefficient is written to registers ROFFS:O2C[7:6], OS2CL and OS2CH</i>	$O2C[15:0] = \frac{\left[\frac{A_{PK}}{96} \right] * 2^{15}}{t_{RISE} * 8 \text{ kHz}}$
Precise position where the trapezoidal signal begins transmitting. If the zero-crossing feature is enabled signal transmission will end at the equivalent phase position.	OS2RPD = transmission or phase delay of up to 32 ms

12.1.3.2.3. RINGING DC OFFSET AND COMMON MODE BIAS

A Ringing DC offset voltage V_{ROFF} can be defined by setting ROFFS:ROS[5:0]

$$ROS[5 : 0] = \left(\frac{V_{ROFF}}{96} \right) * 2^6$$

Ringing DC Offset is enabled when ROFFS:ROS[5:0] contains a non-zero value. V_{ROFF} is added to, or subtracted from, the AC ringing signal depending on the setting. Similarly a Common Ringing Bias voltage V_{CMR} can be defined by setting the VCMR Register.

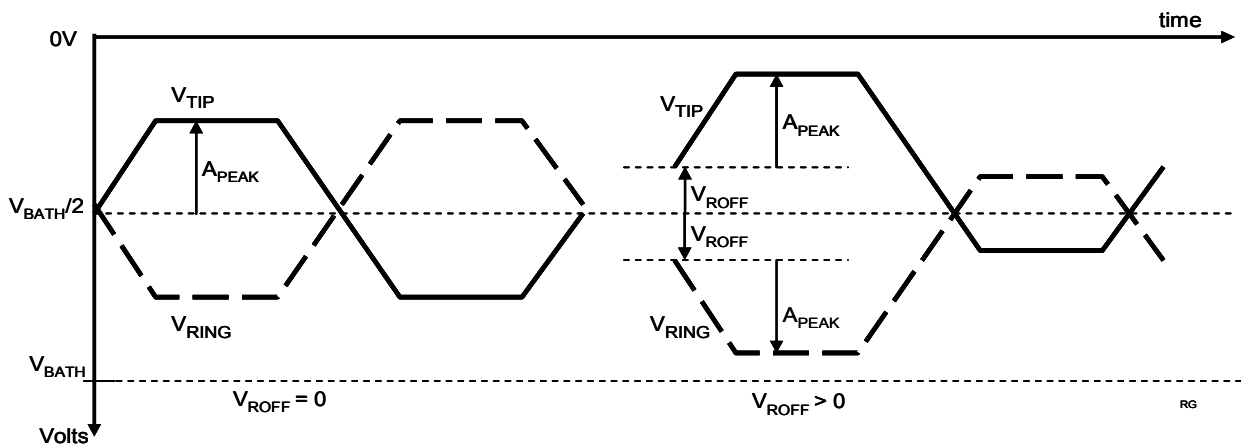

Figure 11: Positive DC offset for Trapezoidal Ringing

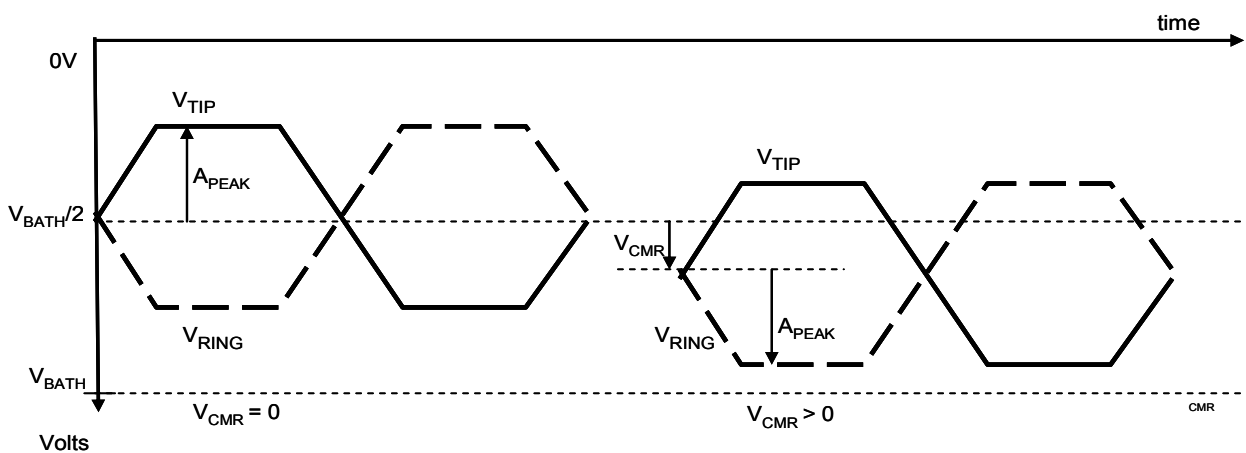

Figure 12: Programming V_{CMR} voltage for Trapezoidal Ringing

12.1.3.2.4. LINEFEED CONSIDERATIONS DURING RINGING

To maintain proper biasing of the external bipolar transistors the generated Ringing signal should stay between the Ringing voltage rails (GNDA and V_{BATH}). If the ringing signal approaches the rails the signal will distort. Furthermore excessive power dissipation in the external transistors will also occur. This can be prevented if V_{BATH} is programmed such that:

$$V_{BATH} > 2 \times \left(A_{PEAK} + V_{ROFF} \right) + V_{CMR}$$

12.1.3.3. INTERNAL UNBALANCED RINGING

An unbalanced ringing waveform can be generated by the N681386/87. This feature is enabled by setting GMV:UBR[7] address (0x4D) to "1". The Ringing signal is only applied to the RING lead and the TIP lead remains at the programmed V_{GM} voltage. The Ringing signal is programmed as described in section 9.1.3.1. A DC offset can be used to provide DC current for Ring Trip Detection (section 9.1.3.2.3). Positive V_{ROFF} values will cause the DC offset point to move closer to ground. The internal unbalanced Ringing waveform is shown below.

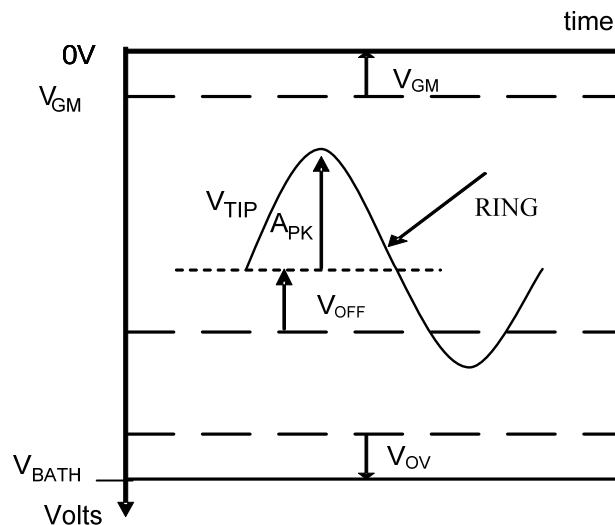

Figure 13: Unbalanced Ringing on TIP

The DC offset value should be set to less than half the ringing amplitude or the ringing signal will be clipped. Reverse unbalanced Ringing waveform can be achieved by setting the GMV:UBR[7] address (0x4D) bit to 1 (the TIP lead oscillates while the RING lead stays constant). In this mode, the polarity of V_{ROFF} must also be reversed.

12.1.3.4. RING TRIP DETECTION

The Ring Trip Detection mechanism is used to recognize an off-hook event during Ringing. The N681386/87 monitors the Loop current through the Loop current circuitry (available at LPI:ILP[11:0] address (0x90)). If the shadow Linefeed state LS:SLS[7:4] address (0x44) indicates a Ringing state the loop current can be used to evaluate whether a Ring Trip event has occurred under two alternative methods - AC path or DC path.

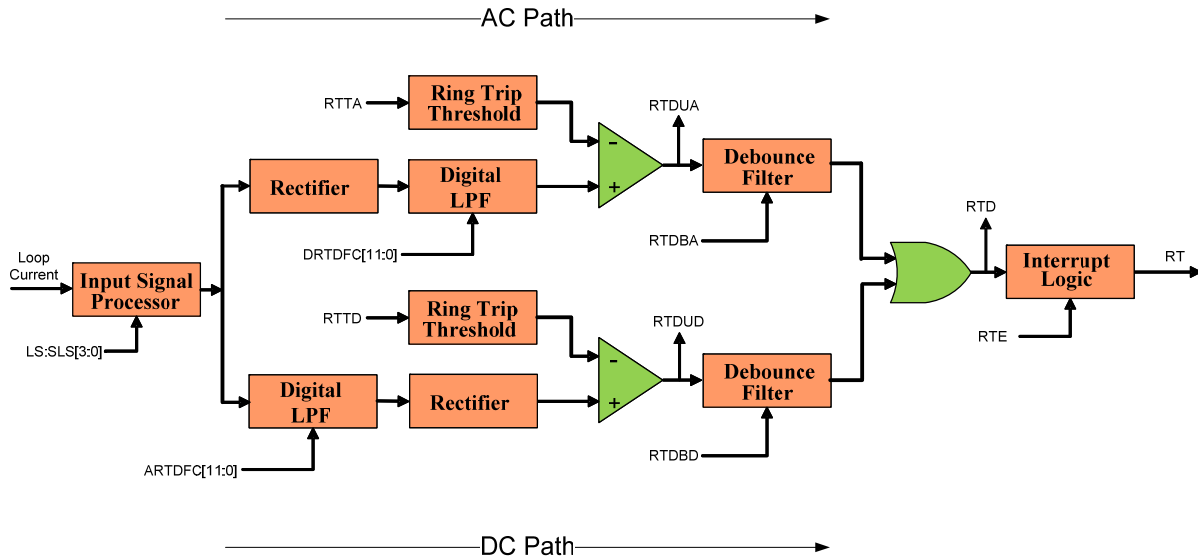

Figure 14: RING Trip Detection Mechanism

For the AC path the AC component of the loop current is determined by passing it first through a full-wave rectifier to remove the DC component and then through a Low Pass Filter for smoothing. The resulting value is compared to the AC path Ring Trip Threshold in register RTTA:ARTT[5:0] address (0x55). A subsequent debounce filter is programmed with an AC Path debounce interval from register RTDBA:ARTDI[7:0] address (0x48). If this interval is satisfied, a valid Ring Trip is judged to have occurred. However, RTLC:RTDUA[3] address (0x46) bit records the unfiltered status of the AC path Ring Trip Detect without regard to the debounce interval.

For the DC path the DC component of the loop current is determined by passing it first through a Low Pass Filter to remove the AC component and then through a rectifier to ensure a positive value. The resulting value then compared against the DC path Ring Trip Threshold in register RTTD:DRTT[5:0] address (0x67) and tested against the DC path debounce interval from register RTDBD:DRTDI[7:0] address (0x68). If this interval is satisfied, a valid Ring Trip is judged to have occurred. However, RTLC:RTDUD[4] address (0x46) bit records the unfiltered status of the DC path Ring Trip Detect without regard to the debounce interval.

If a RingTrip is judged to have occurred either on the AC path or on the DC path RTLC:RTD[1] address (0x46) bit is set. If enabled, a Ring Trip Interrupt will occur. If LAMC:RGA[1] address (0x43) is set the channel will automatically transition into the Active state (Forward or Reverse) upon a valid Ring Trip Detect.

In general, only one detection path should be utilized at one time by maximizing the Ring Trip Threshold value of the unwanted path.

Register	Bit(s)	Address	Parameter	Description / Range
RTTA RTTD	ARTT[5:0] DRTT[5:0]	0x55 0x67	RING Trip Threshold AC & DC	0 to 80 mA in 1.27 mA steps
RTDBA RTDBD	ARTDI[7:0] DRTDI[7:0]	0x48 0x68	RING Trip Detect Debounce Interval	0 to 159 milliseconds
RTDFCLD DCHA RTDFCLD DCHD	ARTDFC[7:0] ARTDFC[11:8] DRTDFC[7:0] DRTDFC[11:8]	0x51 0x52 0x65 0x66	RING Trip Filter Coefficient	For Digital LPF
INT1	RT[0]	0x26	RING Trip Interrupt Pending	Status
IE1	RTE[0]	0x27	RING Trip Interrupt Enable	Enable/Mask
RTL	RTD[1]	0x46	RING Trip Loop Closure Detect Status	Status
LS	SLS[3:0]	0x44	Linefeed Status Control	Ringing Shadow Status
LAMC	RGA[1]	0x43	Enable Oscillators and Transitions Automatically	Control

Table 17: Registers for RING Trip Detection

The cutoff frequency, f_{LP} , of the Digital LPF is programmed in the Ring Trip Filter coefficient RTDFCA[11:0] and RTDFCD[11:0]:

$$RTDFCD[11 : 0] = \left(1 - 2 * \pi * \left(\frac{f_{LP}}{800\text{Hz}} \right) \right) * 2^{12} \qquad RTDFCA[11 : 0] = \left(1 - 2 * \pi * \left(\frac{f_{LP}}{800\text{Hz}} \right) \right) * 2^{12}$$

Values for RTDFCA, RTDFCD, RTTA, RTTD, RTDBD and RTDBA vary according to the programmed ringing frequency. The following table can be used for reference.

Ringing Frequency Hz	RTDFCD[11:0] RTDFCA[11:0]		RTTA RTTD		RTDBD RTDBA	
	Decimal	Hex	Decimal	Hex	Decimal	Hex
16.667	3561	0x0DE9	34 mA	3600	15 ms	0x0C
20	3453	0x0D7D	34 mA	3600	12.5 ms	0x0A
30	3132	0x0C3C	34 mA	3600	8.75 ms	0x07
40	2810	0x0AFA	34 mA	3600	7.5 ms	0x06
50	2489	0x09B9	34 mA	3600	5 ms	0x04
60	2167	0x0877	34 mA	3600	5 ms	0x04

Table 18: Recommended RING Trip Values for Ringing

12.1.4. SUPERVISION (SIGNALING)
12.1.4.1. LOOP CLOSURE DETECTION

The recognition of an off-hook event outside Ringing is controlled by the Loop Closure Detect mechanism. Figure 16 shows the functional block.

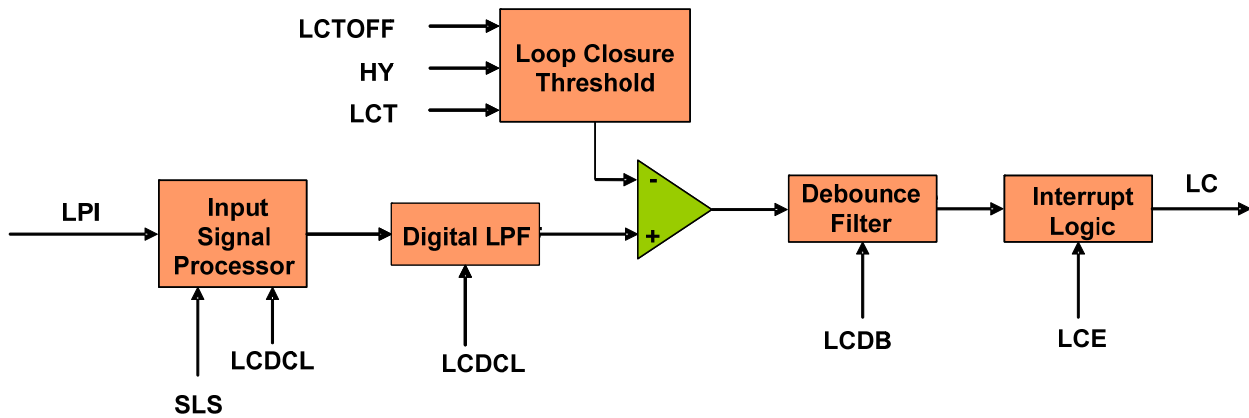

Figure 15: Loop Closure Detector Block Diagram

Loop current monitoring circuitry provides a Loop Current value which can be read at LPI:ILP[11:0] address (0x90) register. If the shadow linefeed state LS:SLS[7:4] address (0x44) indicates any state other than Open or Ringing state, the Loop Current value is fed to a digital Low Pass Filter to remove unwanted AC components. The cutoff frequency, f_{LP} , of the Digital LPF is programmed in the Loop Closure Detect Filter coefficient LCDCL:LCDC[11:0] address (0x50).

$$LCDC[11 : 0] = \left(1 - 2 * \pi * \left(\frac{f_{LP}}{800\text{Hz}} \right) \right) * 2^{12}$$

The resulting value is compared to a Loop Current Detect Threshold value in register LCT[5:0] address (0x53). However if the transition is an off-hook to an on-hook transition with hysteresis is enabled LCTHY:LCHYEN[6]=1 address (0x54), the threshold value in LCTHY:LCTOFF[5:0] address (0x54) is used in the comparison. A subsequent debounce filter is programmed with a debounce interval from register LCDB:LCDI[7:0] address (0x47). In addition, a special mask counter LCMCNT:LCMCNT[7:0] address (0xAB) can be enabled using RTLCL:LCM[6] address (0x46) to guard against detects due to transients on the line, which can occur with reactive ringers. The RTLCL:LCDU[2] address (0x46) bit records the unfiltered status of Loop Closure Detect without regard to the debounce interval or the Mask count. If the interval is satisfied a valid Loop Closure is judged to have occurred and the RTLCL:LCD[0] address (0x46) bit is set. An interrupt can be enabled when the Loop Closure Interrupt occurred.

Register	Bit(s)	Address	Parameter	Description / Range
LCT	LCT[5:0]	0x53	Loop Closure Threshold	Current Based: 0-80 mA @ 1.27 mA Voltage based: 0-93.5V @ 1.484V
LPI	ILP[11:0]	0x90	Loop Closure	Current Based: 0-78.74 mA @ 1.25 mA
LCTHY	LCHYEN[6]	0x54	Enable Hysteresis	
LCTHY	LCTOFF[5:0]	0x54	Loop Closure Threshold Off-Hook to ON-HOOK state Enable Hysteresis	When hysteresis enabled only opposite transition governed by LCT. Current Based: 0-80 mA @ 1.27 mA Voltage based: 0-93.5V @ 1.484V
LCDB	LCDI[7:0]	0x47	Loop Closure Detect Debounce Interval	0 to 159 milliseconds
LCDC DCH	LCDC[7:0] LCDC[11:8]	0x50 0x52	Loop Closure Filter Coefficient	For Digital LPF
INT1	LC[1]	0x26	Loop Closure Interrupt Pending	Status
IE1	LCE[1]	0x27	Loop Closure Interrupt Enable	Enable/Mask
RTL	LCD[0]	0x46	Loop Closure Detect Status	Status / Enable Voltage-based Loop Closure
LCMC	LCMCNT[7:0]	0xAB	Loop Closure Detect Mask Counter	0 to 319 ms in 1.25 ms steps
LAMC	LCDA[0]	0x43	Enable Automatic Transitions	Control

Table 19: Loop Closure Detection Registers

If LAMC:LCDA[1] address (0x43) is set the channel will automatically transition from the Idle (Forward or Reverse), ON-HOOK Transmission (Forward or Reverse) as well as TIP Open or RING Open into the Active (Forward or Reverse) state upon a valid Loop Closure Detect.

Voltage based Loop Closure Detect can also be enabled by setting bit RTL:VBLC[5] address (0x46). In this case the input signal is the Loop Voltage and the thresholds are interpreted as voltages. All other functionality is the same.

12.1.4.2. GROUND KEY DETECTION

Ground Key Detect (GKD) senses a DC current imbalance between the TIP and RING terminals when the RING terminal is connected to ground. This feature is commonly associated with PBX signaling. The feature is enabled in all states except Ringing. Figure below shows the functional blocks for ground key detector.

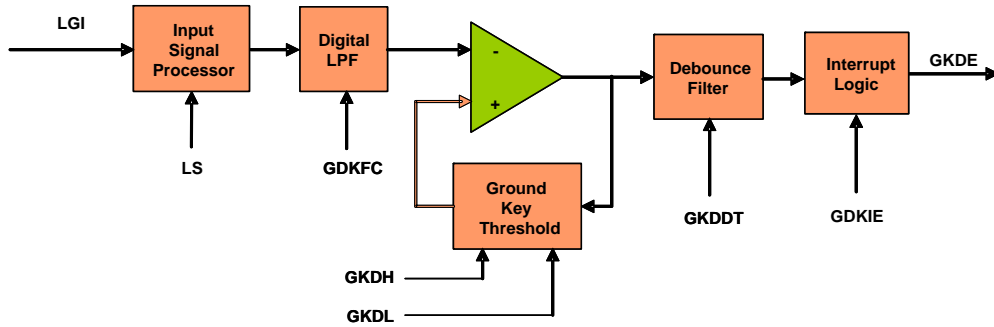

Figure 16: Ground Key Detection Circuitry

Ground Key Detection is enabled by setting the GKDFCH:GKDEN[7] address (0x64). The input to the GKD circuitry is the longitudinal current, which is available in register LGI:ILG[11:0] address (0x8C). If the shadow linefeed state LS:SLS[7:4] address (0x44) indicates a non-Ringing state, the longitudinal current is fed to a programmable Digital Low Pass Filter to remove any unwanted AC components. If f_{LP} is the desired cutoff frequency LPF the Low Pass Filter Coefficient FCGKD[11:0] address (0x63) is calculated using the following equation:

$$FCGKD[11 : 0] = \left(1 - 2 * \pi * \left(\frac{f_{LP}}{800Hz} \right) \right) * 2^{12}$$

A typical value of 10 (CKDFC:FCGKD[11:0] = 00A) is sufficient to filter out any unwanted ac artifacts while allowing the dc information to pass through the filter.

Register	Bit(s)	Addr	Parameter	Range	Increment	Resolution
INT3	GKDE[3]	0x2A	Ground Key Interrupt Pending	Yes/No	N/A	N/A
IE3	GKDIE[3]	0x2B	Ground Key Interrupt Enable	Yes/No	N/A	N/A
GKDDT	DTGKD[7:0]	0x62	Ground Key Detect Debounce Interval	0 to 320ms	1.25ms	1.25ms
LGI	ILG[11:0]	0x8C	Longitudinal Current	Monitor only		500uA
GKDH	HGKD[5:0]	0x60	Ground Key Threshold (enabled)	0 to 80 mA	1.27mA	1.27mA
GKDL	LGKD[5:0]	0x61	Ground Key Threshold (released)	0 to 80 mA	1.27mA	1.27mA
GKDFC	FCGKD[11:0]	0x63	Ground Key Filter Coefficient	0 to 4000h	N/A	N/A

Table 20: Ground Key Detection Registers

The resulting value from the Low Pass Filter is compared to a Ground Key Detect High Threshold GKDH:HGKD[5:0] address (0x60) value. Hysteresis is enabled automatically by programming a second threshold GKDL:LGKD[5:0] address (0x61) to detect when the Ground Key is released. The output of the comparator is connected to a programmable debounce filter. It can be programmed with a debounce interval GKDDT address (0x62).

12.1.4.3. CALLER ID AND FSK GENERATION

The N681386/87 provides an optimized Frequency-shift keying (FSK) generator for sending Caller ID information. Both Bell 202 and ITU-T V.23 standard FSK are supported. The FSK generation supports both Type I and Type II Caller ID with ability to generate CPE Alerting Signals (CAS tones) of 2130 Hz and 2750 Hz. The linear FSK waveform generator provides a mechanism to generate the linear code of FSK with continuous phase.

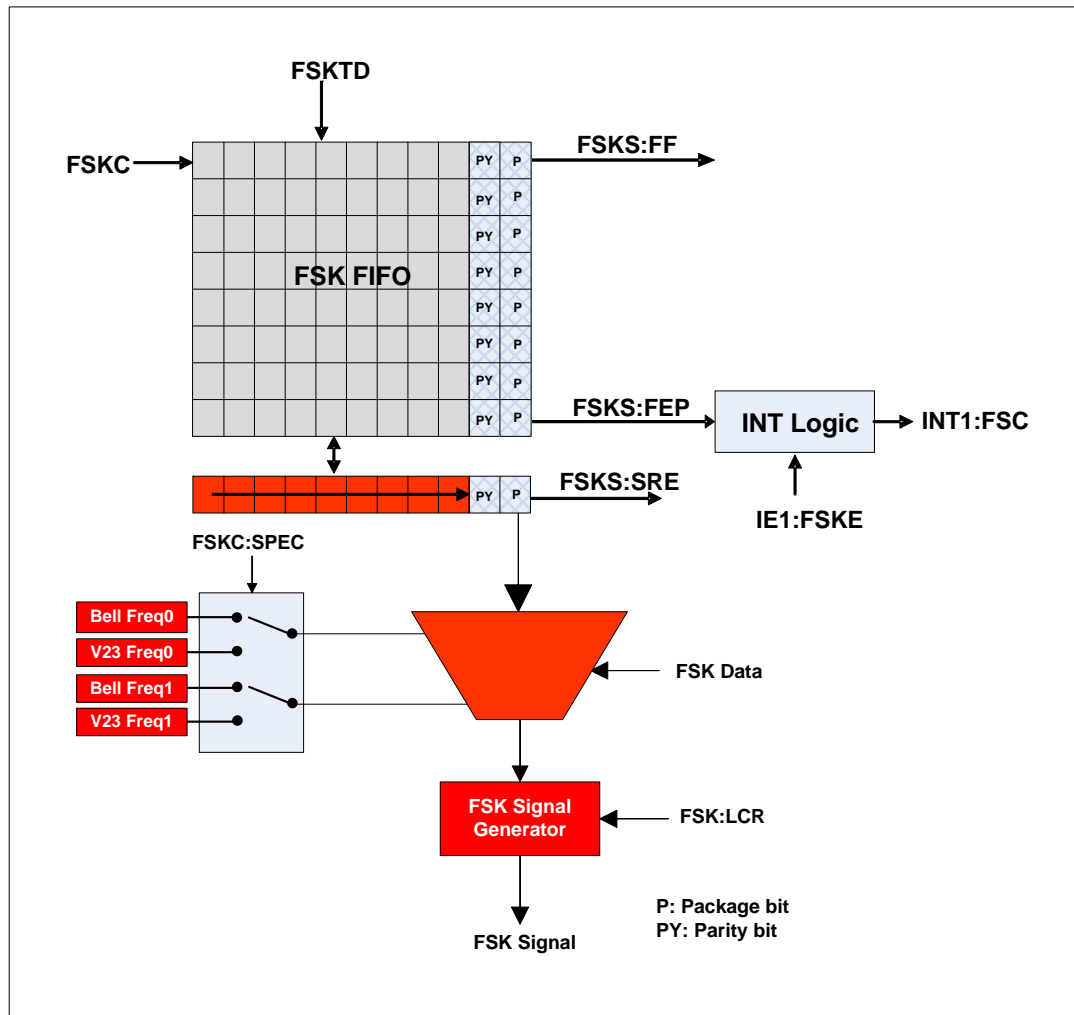

Figure 17: The Architecture of Linear FSK Waveform Generator

As the above figure illustrates, an 8-byte FIFO substantially reduces CPU intervention in generating FSK. Transmitted FSK data is placed in the FIFO by writing to the FSKTD:FSK[7:0] address (0x11) register. The writing process can be controlled by the status bits in the FSKS address (0x12) register which inform on the FIFO's current status.

FSK transmission is initiated by asserting FSKC:TX[3] address (0x10). The FSK transmit data is clocked out of the FIFO one byte at a time beginning with the LSB. If package mode is enabled a 'start bit' (Space) will automatically be amended to the head of the FSK transmit data. Furthermore, one or two 'stop bits' (Mark) are added to the end of the FSK transmit data, depending on the setting of FSKC:STOP[2] address (0x10). If package mode is not enabled the FSK transmit data is transmitted as it appears in the FSK FIFO.

There is one FSK generation engine available inside the N681386/87. An FSK interrupt is generated if the FIFO is empty. The gain of the FSK signal can also be adjusted using FSKLCR:GAIN[3:0] address (0x13) register.

Register	Bit(s)	Address	Parameter	Description / Range
FSKC		0x10	FSK Control Register	Control
FSKTD	FSK[7:0]	0x11	FSK Transmit Data	Binary signal to be transmitted
FSKS	FF[2] FEP[0]	0x12	FSK Status Register	FIFO and Shift Register Status
FSKLCR	GAIN[3:0]	0x13	FSK Gain	See Register Description
FSKTCR	FSKR[1]	0x14	FSK Route	Route FSK Data
INT2	FSKI[7]	0x28	Interrupt Status Registers	Status
IE2	FSKIE[7]	0x29	Interrupt Enable Register	Enable/Mask

Table 21: Registers for FSK Generation

12.1.4.4. DTMF GENERATOR

In Dual Tone Multi Frequency (DTMF) two tones are used to generate a DTMF digit. One tone is chosen from four possible row tones, and one tone is chosen from four possible column tones. The sum of these two tones constitutes one of 16 possible DTMF digits.

Row Frequency	Hz	Column frequency			
		1209	1336	1477	1633
697		1	2	3	A
770		4	5	6	B
852		7	8	9	C
941		*	0	#	D

Table 22: DTMF frequency mapping

DTMF tone generation can be achieved by using both oscillator 1 and oscillator 2. The table below illustrates the oscillator coefficient and initial condition which are required for the standard DTMF tone frequencies. For timing

integrity both oscillators should be enabled simultaneously. Tones can be directed either towards the line or the PCM interface by programming the RMPC:TRAP[7] bit address (0xC1).

Frequency (Hz)	A _{PK} (Volts)	O1C[15:0] or O2C[17:2]		OmIC[15:0]	
		Decimal	Hex	Decimal	Hex
697	0.31	31548	7B3C	1733	06C5
770	0.31	31281	7A31	1909	0775
852	0.31	30951	78E7	2105	0839
941	0.31	30556	775C	2315	090B
1209	0.55	29144	71D8	2930	0B72
1336	0.55	28361	6EC9	3211	0C8B
1477	0.55	27409	6B11	3513	0DB9
1633	0.55	26258	6692	3834	0EFA

Table 22: DTMF frequency settings (A_{PK} values for line impedance =600 Ω)

For a desired frequency f_D the oscillator coefficient for Oscillator m , O1C[15:0] or O2C[17:2], can be calculated with the following equation. The following equations can be used for both Narrowband and Wideband. The resulting hexadecimal coefficients are register data of OSMCH and OSMCL.

$$O1C[15:0] = \cos \left[\frac{2 * \pi * f_D}{16\text{kHz}} \right] * 2^{15} \qquad O2C[17:0] = \cos \left[\frac{2 * \pi * f_D}{16\text{kHz}} \right] * 2^{17}$$

The initial condition for Oscillator m , OSMICL[15:0], can be calculated using the following equation. The following equations can be used for both Narrowband and Wideband.

$$OmIC[15:0] = A * \sin \left[\frac{2 * \pi * f_D}{16 \text{ kHz}} \right] * 2^{15} \quad (m: 1, 2)$$

Where A is calculated from the desired peak amplitude, A_{PK}, in volts in the following equation

$$A = \frac{A_{PK}}{1.5779}$$

The resulting hexadecimal coefficient is input to registers OS2ICH and OS2ICL.

12.1.4.5. DTMF DETECTION

Dual Tone Multi Frequency (DTMF) tones consist of a low tone of 697Hz, 770Hz, 852Hz or 941Hz and high tone of 1209Hz, 1336Hz, 1477Hz or 1633Hz. The incoming signal is separated into high-group and low-group tones, and detected by high-group and low-group tone detectors respectively. When valid data is detected the result is pushed onto a FIFO which can be read by the host through the SPI interface.

When DTMF detection is enabled channel data is scanned for DTMF tones. Three critical time periods associated with detection can be programmed. A signal must be present for a minimum of PDT (Present Detect Time) before tone detection is triggered. Once valid tone is triggered, the tone must be present for ACCT seconds. Once this is true, DTMFRDY is active and the received data is pushed onto the FIFO. When the tone is removed, no detection is triggered for ADT (Absent Detect Time) seconds. DTMFRXDATA is decoded from the row and column frequency according to Table 22. The sensitivity and precision of detection can also be programmed.

When a DTMF tone is detected the N681386 can be configured to generate an interrupt to the host processor for service.

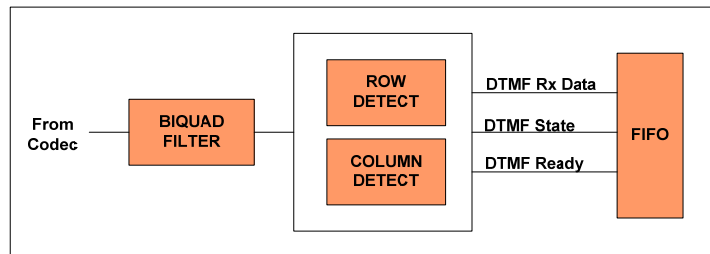

Figure 18: DTMF Detector - Functional Block Diagram

		Column frequency			
		1209 Hz	1336 Hz	1477 Hz	1633 Hz
Row Frequency	697 Hz	1	2	3	A
		0x01 hex	0x02 hex	0x03 hex	0x0D hex
	770 Hz	4	5	6	B
		0x04 hex	0x05 hex	0x06 hex	0x0E hex
852 Hz	7	8	9	C	
	0x07 hex	0x08 hex	0x09 hex	0x0F hex	
941 Hz	*	0	#	D	
	0x0B hex	0x0A hex	0x0C hex	0x00 hex	

Table 22: DTMF Tone Decoding

12.1.5. CODEC

The N681386/87 converts the analog transmit signal into a PCM code, either by using μ -Law, A-Law or linear PCM, and vice versa. A-Law, μ -Law and PCM encoding and decoding is performed according to the recommendations in the ITU-T G.711 specification. In the linear PCM mode a 16-bit 2s complement data format is used. Details of the Decode and Encode Characteristics are to be found in Section 11.

12.1.6. HYBRID

12.1.6.1. AC PATH

The N681386/87 is used for digitizing and reconstructing the human voice. To digitize intelligible voice requires a signal to distortion ratio (S/D) of about 30 dB over a dynamic range of about 40 dB. N681386/87 meets this requirement by a large margin. The complete AC signal path block diagram is shown in Figure 3.

12.1.6.1.1. NARROWBAND TRANSMIT PATH

The gain of this amplifier can be set by programming in APG:ATX[1:0] so that the signal takes advantage of the full range of the A/D. An anti-aliasing filter also precedes the A/D. The A/D produces a 16-bit linear PCM data stream sampled at 8 kHz. The A/D not only exceeds ITU G.712 and G.711 but also expands the voice-band cut-off frequency from a standard 3.4 kHz to 3.6 kHz for enhanced voice quality. High pass filter HXP implements the high-pass attenuation requirements for signals below 65 Hz. The linear PCM data stream is then amplified by the A/D digital gain amplifier, programmable from $-\infty$ dB to 6 dB and allowing fine gain adjustments down to a resolution of 0.1 dB. When enabled, the DTMF decoder can access this data stream at this point. Finally, if companding is selected, A-law or μ -law compression reduces the data stream to 8 bits wide. The timeslot on the PCM interface can be configured with either 8-bit compressed or 16-bit uncompressed data in mind.

12.1.6.1.2. NARROWBAND RECEIVE PATH

In the receive path, data taken from the PCM highway can be 16-bit uncompressed or A-law / μ -law 8-bit compressed. In the latter case it is first expanded to 16-bit data. The linear PCM data stream is then amplified by the D/A digital gain amplifier, programmable from $-\infty$ dB to 6 dB and allowing fine gain adjustments down to a resolution of 0.1 dB. The data stream is then put through an optional high pass filter to filter out signals below 65 Hz and a low-pass interpolation filter again with 3.6 KHz cutoff frequency for enhanced voice quality before being passed to the D/A. Finally, the analog signal is amplified by the Analog Receive Amplifier. The gain of this amplifier can be set by programming in APG:ARX[1:0] before the signal is output from the chip.

The 12-bit digital gain blocks in both the transmit and receive paths provide 11 bits (1024 steps) for fine tuning the audio signals while the MSB can be used to invert the signal. To calculate the gain setting Y based on the desired dB setting X, the equation is:

$$Y = 1024 \times 10^{\left(\frac{X_{dB}}{20}\right)}$$

Conversely, to calculate the dB value of the gain based on known gain step values, the equation is:

$$X \text{ dB} = 20 \times \log_{10} \left(\frac{Y}{1024} \right)$$

The table below contains a sample of possible gain settings.

dB	Gain	Gain Setting (Y)
$-\infty$	Off	0x000
-24	1 / 8	0x040
-12	1 / 4	0x100
-6	1 / 2	0x200
0	1	0x400
6	2	0x7FF

Table 23: Digital Gain Adjust Coefficients and Attenuation weightings

The device exceeds the maximum ITU requirements for frequency response, group delay distortion and signal to distortion as can be verified from the diagrams in Section 11. Audio signals larger than 0dBm0 can be processed without clipping in either compression scheme. The maximum PCM code generated for a sine wave is 3.17 dBm0 (μ -law) or 3.14 dBm0 (A-law).

The N681386/87 overload clipping limits are driven by the PCM encoding process. The presence of a high-pass filter transfer function ensures at least 30 dB of attenuation for signals below 65 Hz. The Low Pass Filter transfer function which attenuates signals above 3.6 kHz has to exceed the requirements specified by ITU G.714 and it is implemented as part of the A/D. The receive path transfer function requirement is very similar to the transmit path transfer function. We have added the high-pass filter portion as a user controlled option. Pass-band has been defined between 300 Hz to 3600 Hz. As the PCM data rate is 8 kHz, no frequencies greater than 4 kHz can be digitally encoded in the data stream.

12.1.6.1.3. ANALOG TRANSHYBRID BALANCING

The N681386/87 provides fully programmable hybrid balancing to cancel transmit and receive signal echo on the full-duplex 2-wire pair. The hybrid balancing is performed at the internal 4-wire port. It is measured as the ratio of the un-cancelled return signal to the reference signal (digital-to-digital gain). Although the ITU standard recommends a hybrid balance below -18 dB within the voice band, care has been taken to reduce this further to -30 dB in order to avoid unacceptable voice quality for packet based networks.

The Tran hybrid Balance is internally set to subtract a -6 dB level from the transmit path signal, corresponding to the ideal case when the impedance matching perfectly matches the subscriber loop. This level can be adjusted from -

2.77 dB to +4.08 dB around this ideal setting by programming HB address (0x41). This register can also be used to disable the Tran hybrid balancing completely. It should also be noted that Tran hybrid Balance adjustments are independent of any other gain adjustment stages as the level shift occurs on the transmit path before any gain stages, as can be seen on Figure 3.

12.1.6.1.4. IMPEDANCE MATCHING

The device provides on-chip programmable two-wire impedance settings to meet a wide variety of worldwide two-wire return loss requirements.

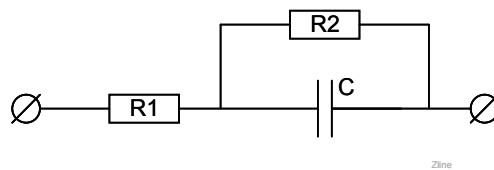

Figure 19: Characteristic Line Impedance

Figure above illustrates the characteristic line impedance model implemented on-chip. Examples of the standard impedances which the N681386/87 supports are shown below.

Country	Requirement Impedance Element (Unit)		
	R1(Ohm)	R2(Ohm)	C(Farad)
US PBX, Korea, Taiwan	600	Open	Short
Standard	900	Open	Short

Table 24: Examples of Resistive Impedance Matching

Pure Resistive Impedance Settings (for example 600 Ohm and 900 Ohm) can be selected in IM1:ZR1[3:0]. In this case Complex Impedance Matching should be disabled by setting IMCTRL:IMEN[2] to 1. Register ILIM:ZCPEN[6] address (0x23) allows magnitude of the AC signal to be increased to compensate for the additional loss at the high end of the audio frequency range. ILIM:ZCPEN[6] should be enabled for Pure Resistive Impedance Matching cases.

Country	Requirement Impedance Element (Unit)		
	R1(Ohm)	R2(Ohm)	C(Farad)
Japan CO	600	Open	1u
Bellcore	900	Open	2.2u
CTR21	270	750	150n
China CO	200	680	100n
China PBX	200	560	100n
Japan PBX	100	1000	100n

Country	Requirement Impedance Element (Unit)		
	R1(Ohm)	R2(Ohm)	C(Farad)
India, New Zealand	370	620	310n
Germany (Legacy)	220	820	115n
UK (Legacy)	320	1050	230n
Australia	220	820	120n

Table 25: Examples of Complex Impedance Matching

Complex Impedance Settings are realized using the Impedance Matching Coefficients loaded into IMRAM 0xF3 using control functions in IMCTRL 0xF5. In this case IM1:ZR1[3:0] should be should be set to 0 (600 Ohm Setting). ILIM:ZCPEN[6] should be disabled for Complex Impedance Settings.

12.1.6.1.5. DAC/ADC AUTOMUTE

When the selected input data source is equal to zero for 1024 consecutive sample cycles, a mute signal is asserted to the analog front end to mute the line output signal. The control output is de-asserted on the first non-zero sample. Automute is enabled by setting AUTOMT:AUTOMTEN[7] address (0x5E). Automute has the capability of selecting two different options such as either DAC and ADC data or only DAC data by AUTOMTSEL[6] address (0x5E).

Register	Bit(s)	Address	Parameter	Description / Range
AMT	AMTEN[7]	0x5E	Automute Enable	0 = Automute disabled (default) 1 = Automute enabled
AMT	AMTSEL[6]	0x5E	Automute Select	0 = DAC data+ADC data (default) 1 = DAC data only

Table 26: Registers for Automute

Automute Threshold	
Modes	AMTTHR[5:0]
Linear	0
u-Law	0
A-law	8

12.1.7. TESTING

The N681386/87 includes extensive test and diagnostics features. Real-time DC linefeed measurements are available through the several voltages and current registers. GR-909 line test capabilities can also be supported. In addition five loop back test options, three digital loop backs (DLP1, DLP2 and DLP3) and two analog loop backs (ALP1, ALP2) are available. Figure 3, details the AC path architecture and also indicates the precise locations of the test loop backs.

12.1.7.1. LOOP BACK TESTS

The full analog loop back LB:ALP2[4] address (0x21) allows the testing of almost all the circuitry of both transmit and receive paths. The compressed 8-bit/16-bit linear transmit data stream is fed back serially to the input of the receive path expander. The signal path starts with the analog signal at the input of the transmit path and ends with an analog signal at the output of the receive path. LB:ALP1[3] address (0x21) takes the digital stream at the output of the A/D in the transmit path and feeds it back to the input of the D/A in the receive path. As with LB:ALP2[4] address (0x21) the signal path starts with the analog signal at the input of the transmit path and ends with an analog signal at the output of the receive path.

Full digital loop back LB:DLP1[0] address (0x21) tests practically all transmit and receive path circuitry. The analog signal at the output of the receive path is fed back to the input of the transmit path by way of the Trans-hybrid filter path. The Trans-hybrid balance may be set to unity gain so that the return signal is not attenuated. A switch in the receive path is opened when this loop is selected so that no signal appears on the line during this loop back. The signal path starts with 8-bit/16-bit PCM data input to the receive path and ends with 8-bit/16-bit PCM data at the output of the transmit path. The user can bypass the companding process and interface directly to the 16-bit data. LB:DLP2[1] address (0x21) takes the digital stream at the input of the D/A in the receive path and feeds it back to the output of the A/D in the transmit path. The signal path starts with 8-bit/16-bit PCM data input to the receive path and ends with 8-bit/16-bit PCM data at the output of the transmit path. This loop back option allows the testing of the digital signal processing circuitry of the N681386/87 independent of any analog signal processing activity. DLP3 loops the digital data stream just beyond the PCM interface, taking the 8-bit/16-bit output of the PCM receive interface and looping directly to the input of the PCM transmit interface.

12.1.7.2. DIAGNOSTICS SUPPORT

The N681386/87 provides a variety of registers which provide both voltages and current values from the line which are either measured or calculated (see tables 7 and 8). These registers are updated at a rate of 800 Hz or every 1.25 msec. Furthermore, the N681386/87 provides several mathematical and sampling resources to derive additional data useful in diagnostics (see illustration below). For example, peak to peak measurement results of the loop current and loop voltage is available in registers ILPP2P:LPIP2P[11:0] address (0x9C) and VLPP2P:LPVP2P[11:0] address (0x9B). These measured calculated and derived register values can be used to do GR-909 diagnostic tests.

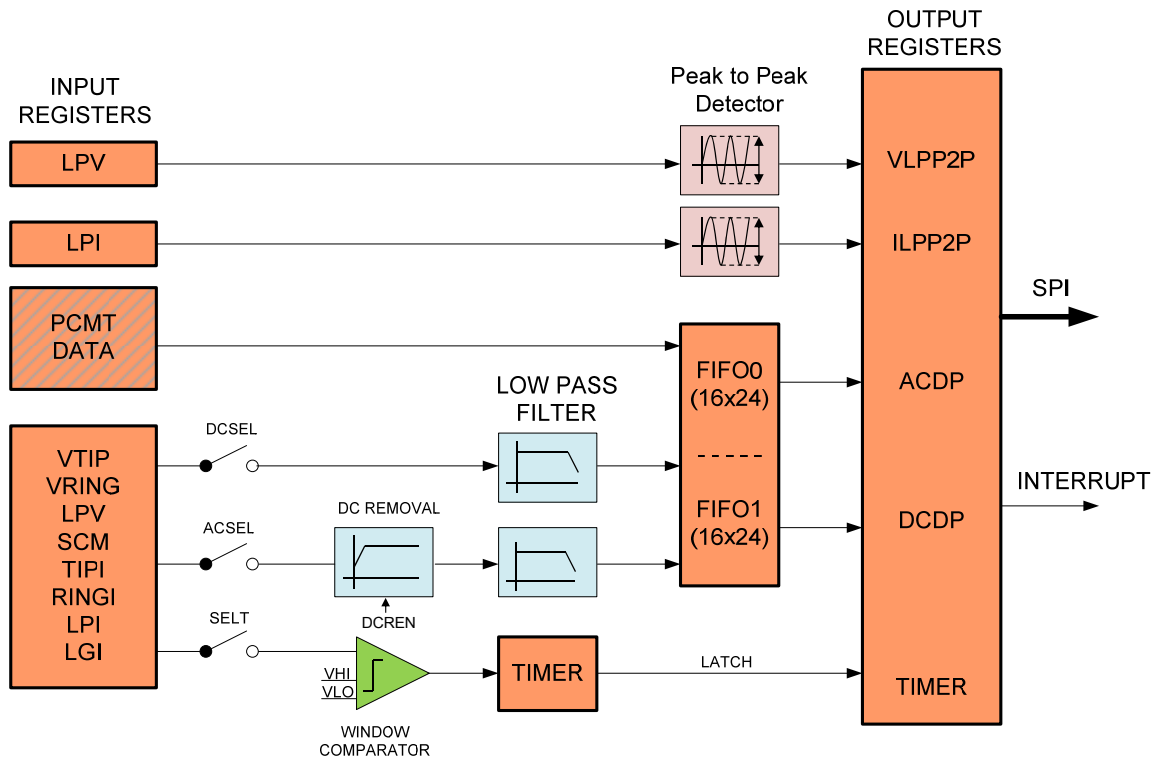

Figure 20: Diagnostics Support Block Diagram

12.1.8. POWER INTERFACE

The N681386/87 utilizes low-cost external components for to perform the DC/DC conversion to the high voltages required for the subscriber line interface (SLIC). The external discrete circuitry is controlled by on-chip pulse width modulation (PWM) driver.

The battery voltage circuit and PWM driver provide a closed loop system for battery voltage regulation. Battery voltage, V_{BAT} , is monitored and compared to an internal target and adjustments are made accordingly. The target voltage will change, depending on different architectures and such factors as the linefeed state. As illustrated in

Figure 21 for example, if the device is operating in the constant voltage region the V_{BAT} target is a combination of V_{OV} , V_{OH} and V_{GM} . A combination of coarse and fine adjustments ensures rapid convergence on the target voltage.

Two different DC/DC conversion architectures are supported and described in the following sections. Two different internal PLL master clocks (13.824 MHz, or 27.648 MHz) can be selected depending on the settings of PON:CDCC[7] address (0x22) and PLLS:PLLCM address (0x04). The width of the pulse generated by the PWM is programmed in PWMT:PT[7:0] address (0x49). A minimum off-time is programmable in the DDCC:DCOFF[7:0] address (0x4A) to allow sufficient time for stored energy to be transferred to the output capacitor. For reference monitoring the actual PWM pulse width can be checked in the read only PWCT:PWCT[7:0] address (0xB5) register. For example, if the PWCT indicates a maximum pulse width consistently, this might indicate an overload condition or a short circuit. The values for PWMT, DDCC and PWCT are based on multiples of the internal PLL master clock period.

Register	Bit(s)	Address	Parameter	Description / Range
PON	CDCC[7]	0x22	Inductor Architecture	
PWMT	PT[7:0]	0x49	Sets PWM Pulse Width for DC/DC converter	Step size and initial value dependant on internal PLL clock selection
DDCC	DCOFF[7:0]	0x4A	Sets PWM minimum Off time for DC/DC convertor	Step size and initial value dependant on internal PLL clock selection
PWCT	PWCT[7:0]	0xB5	PWM Count Register	For Reference (Read only)
DCTR	VTR[7:0]	0x77	DC/DC Target Voltage	0V to -93.5V in 1.484V increments
OHV	VOH[5:0]	0x4C	V_{OH} On-Hook Voltage	0V to -93.5V in 1.484V increments
GMV	VMV[5:0]	0x4D	V_{GM} Ground Margin Voltage	0V to -93.5V in 1.484V increments
VBHV VBLV	VBATH[5:0] VBATL[5:0]	0x4E 0x4F	V_{BATH} High Battery Voltage V_{BATH} Low Battery Voltage	0V to -93.5V in 1.484V increments
VOV	VOV[3:0]	0x56	V_{OV} Offset Voltage	0V to 24 V in 1.484 V increments
BATV	VB[7:0]	0x80	V_{BAT} Battery Voltage	0V to -95.88V in 0.376 V increments

Table 27: Registers associated with DC/DC Conversion

12.1.8.1. DC/DC CONVERSION (INDUCTOR)

A current sensing input for the DC/DC converter provided. The PWM pulse will be muted during each PWM cycle if the current exceeds a predetermined threshold level. This prevents the external discrete transistors from damage due to overload conditions. Similarly, the supply voltage is also monitored. The PWM pulse will be muted during each PWM cycle if the supply voltage falls below a predetermined level. The PWM pulse will also be muted if the battery voltage exceeds 10% of the maximum value. If this threshold is too high, an external clamp can be added in the application. See application diagram.

The Figure below illustrates how voltage regulation occurs in the Forward Active state.

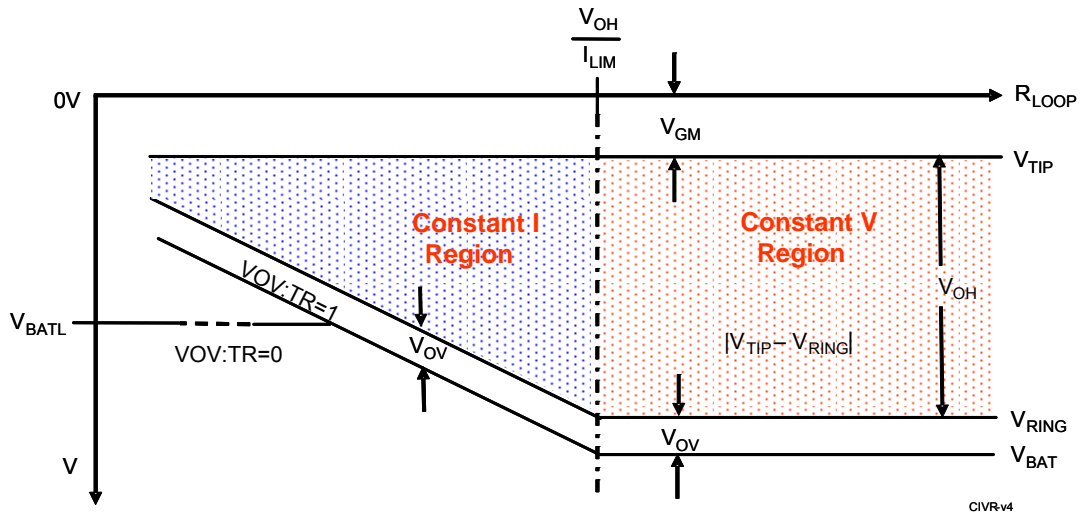

Figure 21: Voltage Tracking in Forward Active State

The values for V_{GM} , V_{OH} and V_{OV} are set in V_{CMR} , O_{HV} , and V_{OV} registers respectively. When operating in the constant voltage region the V_{BAT} is simply the sum of these three settings ($V_{GM} + V_{OH} + V_{OV}$). If the Loop current attempts to exceed I_{LIM} the constant current region is entered. In this case the values for V_{OV} and V_{GM} are maintained but the V_{OH} is adjusted to track the R_{LOOP} , which adjusts V_{BAT} accordingly. If tracking is enabled, $VOV:TR=1$, tracking will continue below V_{BATL} . Otherwise, tracking will stop and V_{BAT} will not go lower than V_{BATL} . A similar mechanism is implemented in the Reverse Active state.

During the Ringing state, the V_{BAT} must be increased to accommodate the ring signal. Conventionally V_{BAT} is set to a fixed value of V_{BATH} . However, the discrete linefeed circuit dissipates significant power particularly when a large REN load is applied. As an alternative the N681386/87 allows a dynamic battery target to be selected by setting the $LCTHY:DBTR[7]$ address (0x54). In this case V_{BAT} will dynamically track the actual ring signal, minimizing the power dissipation and improving efficiency during Ringing. Dynamic Battery Target is available only for DC/DC conversion architecture.

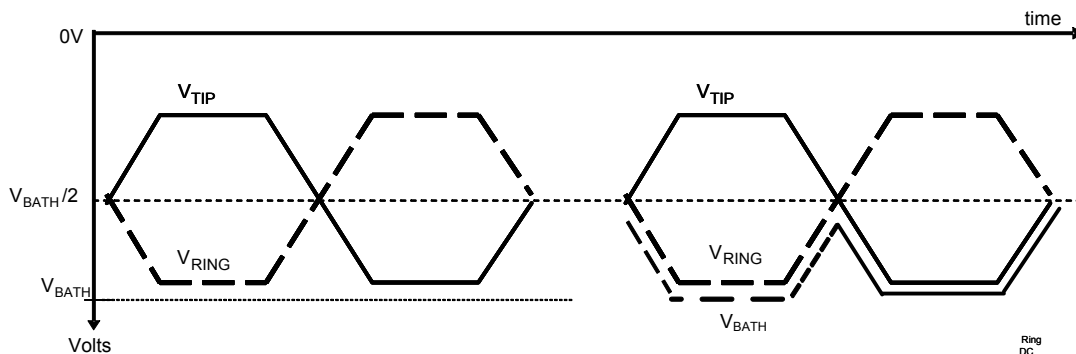

Figure 22: Dynamic Battery Target

12.1.8.2. EXTERNAL BATTERY SWITCHING

The N681386/87 device can also operate from two or three external battery supplies. The external battery supply architecture can be enabled by pulling the XBAT Pin HIGH. This will also power down the on-chip PWM controllers. In this case the N681386/87 utilizes the DCPn and the DCNn pins to control the selection of externally supplied VBATR, VBATH and VBATL for VBAT by means of a external circuit such as the one illustrated below.

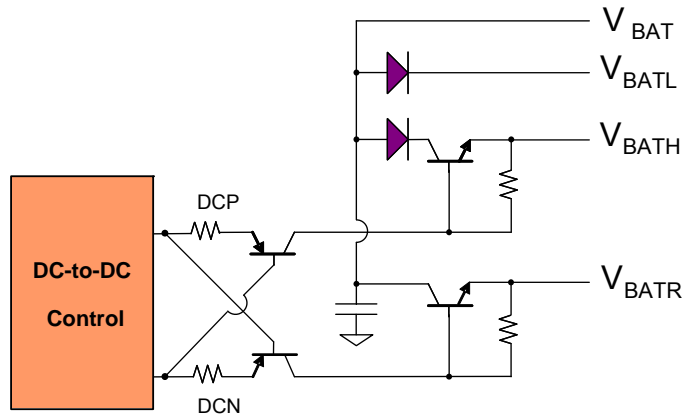

Figure 23: Three Voltage External Battery switching

The V_{BAT} voltage selection is dependent on the linefeed state and the relationship is programmable. The mapping of the DCNn pins output to the linefeed state can be uniquely programmed in the XBSDCN address (0x6A) register as illustrated in the table below. The XBSDCP address (0x6B) register serves the same purpose for the DCPn pins. The combination of DCNn, DCPn outputs and the external selection circuitry allows either VBATR, VBATH or VBATL to be selected in any state.

When two external battery supplies are used (VBATH and VBATL) V_{BAT} selection can be controlled by the one pin alone. Therefore, DCNn should be used to control the external battery switching.

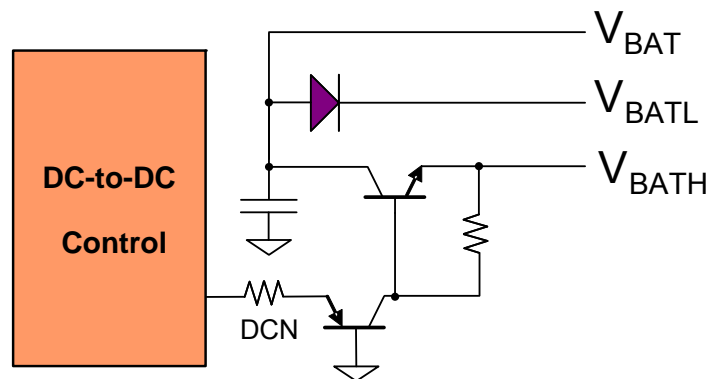

Figure 24: Two Battery Supply Control Circuit

12.2. DIGITAL INTERFACE

12.2.1. CLOCK GENERATION

The N681386/87 will generate the necessary internal clock frequencies from the BCLK input. BCLK must be synchronous to the 8 kHz frame sync clock and run at one of the following rates:

Binary Clock	Decimal Clock
256 kHz	1.000 MHz
512 kHz	2.000 MHz
768 kHz	4.000 MHz
1.024 MHz	8.000 MHz
1.152 MHz	
1.536 MHz	
1.544 MHz	
2.048 MHz	
4.096 MHz	
8.192 MHz.	

The frame sync can either be supplied externally or it can be generated internally by the N681386/87, by setting the PCMFS:FSS[2] address (0x05) bit to “1”. If frame sync is supplied externally (PCMFS:FSS=0), the ratio of the BCLK rate to the frame sync rate is determined via a counter clocked by BCLK which can be read at the PLLS:BCFS[4:1] address (0x04). This value is used to control the internal PLL, which multiplies BCLK appropriately to generate the internal clock frequency required to run the internal circuitry.

If the frame sync is supplied internally (PCMFS:FSS=1), the user must set PCMFS:BF[3:0] to indicate BCLK so that an appropriate multiple is calculated to generate the required internal frequency. If the frame sync is generated internally its width can be selected by programming PCMFS:IFST[3] address (0x05).

- ◆ 1-bit clock long (for Short Frame Sync, GCI and IDL modes)
- ◆ 8-bit clocks long (for 8-bit Long Frame Sync mode)

12.2.2. PCM INTERFACE

N681386/87 supports a flexible PCM interface structure which can be configured to perform multiple industry standard PCM modes. Data is received serially through the PCMR pin and transmitted serially through the PCMT pin.

Timeslots for data transmission and reception are independently configured using registers. Two registers, one for each direction combination, control the selection of the start point for the data timeslot:

- ◆ TTS[9:0]: Transmit Timeslot Start
- ◆ RTS[9:0]: Receive Timeslot Start
- ◆ The start point is defined in terms of a particular the BCLK period within the frame. Once the start of the timeslot is assigned the transfer will continue sequentially.
- ◆ For an 8-bit transfer the timeslot will run from the start point to the start point + 7 BCLK cycles.
- ◆ For a 16-bit transfer the timeslot will run from the start point to the start point + 15 BCLK cycles.

By setting the specific timeslot start points, the N681386/87 can be programmed to support many industry standard PCM interfaces including many Long Frame Sync and Short Frame Sync variants, IDL2 8-bit, 10-bit, B1 and B2 channel timeslots. The table below illustrates this by showing how some standard interface modes may be programmed.

Clocking mode	BCLK PERIODS PER DATA BIT	TTS [7:0] RTS [7:0]
Long Frame Mode	1	0x00000 (slot 1)
Short Frame Mode	1	0x00001 (slot 1)
GCI Mode	2	0x00000
IDL Mode	1	0x00001

Table 28: Example Standard Interface modes

However N681386/87 allows even more flexibility. It can support BCLK up to 8192 kHz, or up to 1024 BCLK periods per 125usec frame. Therefore 10-bit timeslot assignment registers have sufficient flexibility to assign any timeslot start point within the frame. Care should also be taken when dealing with a BCLK lower than 8192 kHz to ensure that the timeslot start point is within the boundary of the frame, including sufficient headroom for the complete timeslot.

For example, if BCLK is 512 kHz there are 64 BCLK cycles within the frame. However, for all modes except Short Frame Sync the highest valid start position for 8-bit PCM data would be 56, sufficient for the full byte to be accommodated within the frame. For 16-bit data the highest start position would be 48. In Short Frame mode the LSB can be located up to the first BCLK of the next frame so the highest valid position is 56 for 8-bit or 48 for 16-bit.

The PCMT pin is high impedance except for the duration of the PCM transmit. PCMT will return to high impedance either on the negative edge of BCLK during the LSB, or on the positive edge of BCLK following the LSB depending on the setting of PCMC:TRI[2] address (0x00). Tri-stating on the negative edge allows the transmission of data by multiple sources in adjacent timeslots without the risk of driver contention.

12.2.2.1. WIDEBAND AND NARROWBAND OPERATION

Nuvoton’s newest design in the Pro-X product line is a Narrowband and Wideband audio codec. The N681386 is limited to Narrowband audio codec communication, meaning 8kHz sampling and 8kHz frame sync with frame sync master mode capability. The Narrowband audio codec communication is compatible with the W681388, N681386, & W684386. The user could write to a reserved register that is used for Wideband operation on **N681386** without any effect to the Narrowband operation.

The **N681387** is capable of both Narrowband and Wideband audio communication. The WBAND pin which is only available on N681387 selects the Narrowband and Wideband. When WBAND pin is LOW the device is in narrowband mode and when the WBAND pin is HIGH the devices is operating in Wideband mode. However, a register PCMFS:WBEN[1] address (0x05) also needs to be programmed to ‘1’ in order to enable wideband operation.

This supports two scenarios:

- 1) The user permanently ties the ‘WBAND’ pin to VDD, while the PCMFS:WBEN[1] address (0x05) register is toggled to enable/disable Wideband
- 2) The user sets the register PCMFS:WBEN[1] address (0x05) to ‘1’ and controls the WBAND pin to enable/disable the Wideband operation.

The table below shows the modes of operation.

WBANDPin	WBEN[1]	FSRATE[5]	FS Frequency	Band Operation (Filter & PCM)
GND	0	0	8kHz	Narrow (Default)
GND	1			Narrow
VDD	0			Narrow
VDD	1	0	8kHz (1 FS with 2 Sample)	Wide
		1	16kHz (1 FS with 1Sample)	

Table 29: Wideband or Narrowband Hardware Selection

The Narrowband mode is limited to 8kHz sampling and frame sync of 8kHz. The Wideband mode of operation is limited to 16kHz sampling and an option of 8kHz or 16kHz frame sync. The user needs to write a register PLLS:FSRATE[5] address (0x04) to indicate whether 8kHz (‘0’) or 16kHz (‘1’) frame sync rate is being used.

There is no frame sync master mode supported in wideband operation.

12.2.2.2. TOGGLING BETWEEN WIDEBAND AND NARROWBAND

It is not recommended to toggle between Wideband and Narrowband when 16kHz frame sync is used, since it could unlock the PLL. However, the architecture may allow it when the pin is toggled at the right time.

For Wideband, using 8kHz frame sync, the user can toggle the WBAND pin or PCMFS:WBEN[1] address (0x05) register, while keeping the frame sync and bit clock running as is. The internal filter and PCM interface of the N681387 will switch to adjust to the Narrowband or Wideband mode of operation. This could lead to temporary glitches on the output while switching the filter. One could briefly mute the DAC and ADC path through the firmware code to prevent the glitches from being audible.

12.2.2.3. PCM INTERFACE IN WIDEBAND OPERATION

12.2.2.3.1. PCM INTERFACE 8KHZ FRAME SYNC

During Wideband operation and 8kHz frame sync the PCM data will be transmitted and received as two samples per frame sync. The location of the MSB of each sample on the PCM bus with respect to the frame sync pulse is programmable through two independent time slot registers. The time slots need to be programmed such that they are 62.5usec apart. An internal data ready signal will be generated to synchronize with the filters to indicate the data is ready and to synchronize the sample rate. The approximate timing diagram is shown below.

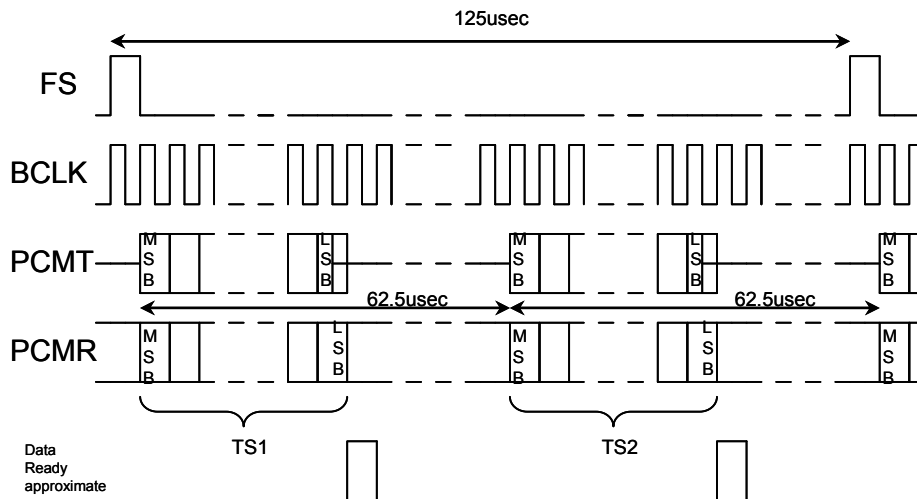

Figure 25: Wideband 8kHz Frame Sync PCM interface

12.2.2.3.2. PCM INTERFACE 16KHz FRAME SYNC

During Wideband operation and 16kHz frame sync the PCM data will be transmitted and received as one sample per frame sync. The location of the MSB of each sample on the PCM bus with respect to the frame sync pulse is programmable through one time slot register. The second timeslot register is not used in this case. Below is shown the approximate timing diagram for this case.

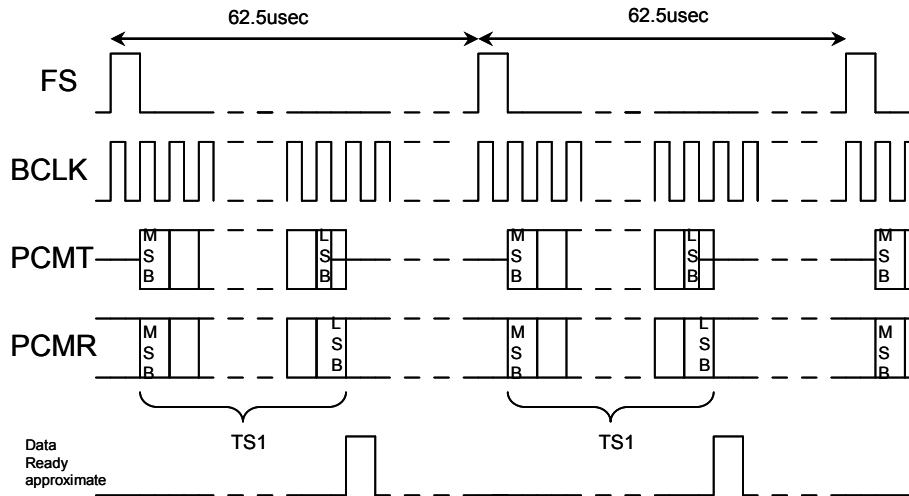

Figure 26: Wideband 16kHz Frame Sync PCM interface

12.2.2.4. PLL & PRESCALER IN WIDEBAND OPERATION

The prescaler determines the external bit clock frequency based on the ratio of the frame sync and bit clock frequency. When the frame sync switches to 16kHz (Wideband) it needs a signal to indicate this change in order to determine the correct bit clock frequency. In wideband and narrowband mode using 8kHz frame sync it doesn't need to adjust. Therefore, the PLL & prescaler operation can be summarized by the following truth table:

WBAND pin	WBEN[1]	FSRATE[5]	PLLWBANDEN (switches prescaler)
GND	'0'	'0'	0
GND	'0'	'1'	0
GND	'1'	'0'	0
GND	'1'	'1'	0
VDD	'0'	'0'	0
VDD	'0'	'1'	0
VDD	'1'	'0'	0
VDD	'1'	'1'	1

Table 30: PLL and Prescaler in Wideband

12.2.3. SERIAL PERIPHERAL INTERFACE (SPI)

The Serial Peripheral Interface (SPI) is one of the widely accepted communication interfaces implemented in Nuvoton's Pro-X portfolio. SPI is a software protocol allowing operation on a simple 4-wire bus where the data is transferred MSB first. The SPI interface consists of a clock (SCLK), chip select (CSb), serial data input (SDI), and serial data output (SDO) to configure all the internal register contents. SCLK is static, allowing the user to stop the clock and then start it again to resume operations where it left off. The SCLK can run any speed up to internal PLL master clock (13.824MHz, 24MHz, or 27.648MHz depending on selected architecture). In the case of a write, DATA is sent by the micro-controller. In the case of a read, DATA is read by the micro-controller. To write data to the chip the controller must follow the following sequence



There are two different Read/Write architecture

- 8-bits Data Read/Write
 - The 8-bits data Write consists of 8-bits of Device Address, 8-bits of Register Address, and 8-bits of DATA.
 - The 8-bits data Read consists of 8-bits of Device Address, 8-bits of Register Address, and 8-bits of DATA.
- 16-bits Data Read/Write
 - The 16-bits data Write consists of 8-bits of Device Address, 8-bits of Register Address, and 16-bits of DATA.
 - The 16-bits data Read consists of 8-bits of Device Address, 8-bits of Register Address, and 16-bits of DATA.

The first byte, Device Address, sent to the N681386/87 from the host controller, following a CSb going HIGH to LOW, contains read/write bit, the Device type Identifier bits (wideband and narrowband selection information), and the burst mode. The 8-bits of the Device Address are explained below.

Name	C7	C6	C5	C4	C3	C2	C1	C0
Device Address	RW	0	0	0	0	CH	XP	BST

Table 31: Device Address Bit pattern

Bit Location	Bit Description	Bit Name	Bit Value	
			0	1
0	Burst mode allows multiple consecutive registers to be written to or read using in a single sequence. The complete register address space (256 locations) can be read and written to using burst mode.	BST	Disable	Enable

Bit Location	Bit Description	Bit Name	Bit Value	
			0	1
1	Control bit to select 12-Bits monitoring	XP	Bits[11-4]	Bits[3-0]
2	This is a channel selection bit. In case of a single channel device this bit must be set to "0"	CH	0	NA
3 - 6	Must be set to "0" for all operation	-	-	-
7	Read/Write control bit	RW	Write	Read

CH	XP	Command
0	0	Register Address (8-bits)
0	1	2 nd byte of 12-Bits monitoring

Table 32: 12-bit byte Selection

12.2.4. READ/WRITE SEQUENCE (8-BIT OR 16-BIT)

The device is accessed via the SDI input with data clocked in on the rising edge of SCLK. DATA transfer is synchronized to the SCLK input. Data is clocked out onto SDO on the falling edges of SCLK. SCLK is the only reference of SDI and SDO pins. The SDO pin will go tri-state when goes CSb HIGH

The first two pictures below illustrate the Read/Write Sequence for an 8-bit architecture. Both Read/Write sequences consist of three 8-bit transmissions, Device address, Register Address and Data. Each 8-bit transmission starts with the falling edge of the CSb line. At the end of every 8-bit transmission is complete the CSb transitions from LOW back to HIGH. After a valid Device Address and Register Address for Read, 8-bit Data is shifted out on the SDO line.

The last two pictures below illustrate the Read/Write Sequence for a 16-bit architecture. Both Read/Write sequences consist of two 16-bit transmissions, the first 16-bit transmission consisting of Device address and Register Address bytes and the second 16-bit transmission consists of Data. Each 16-bit transmission starts with the falling edge of the CSb line. At the end of every 16-bit transmission CSb transitions from LOW back to HIGH. After a valid Device address and Register Address for Read, 16-bits of Data is shifted out on the SDO line. Since all the registers are 8-bits long, the least significant byte of the 16-bit Data word should be ignored. If additional clocks are sent by the master the device will provide the same data when BST is LOW.

The SPI state machine soft resets whenever CSb asserts during an operation on an SCLK cycle that is not a multiple of eight, including burst mode. This is a mechanism for the controller to force the state machine to a known state when the controller and the device are out of synchronization.

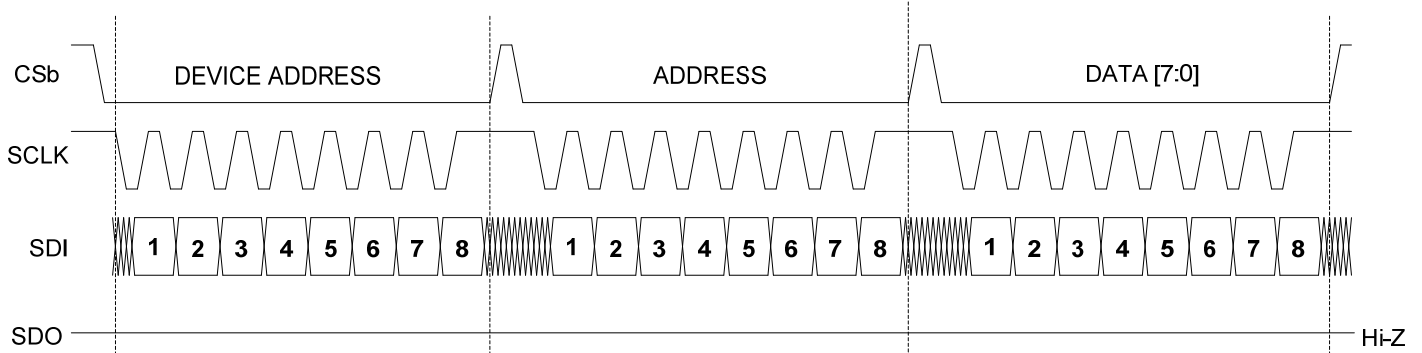

Figure 27: Register write operation through a 8-bit SPI port

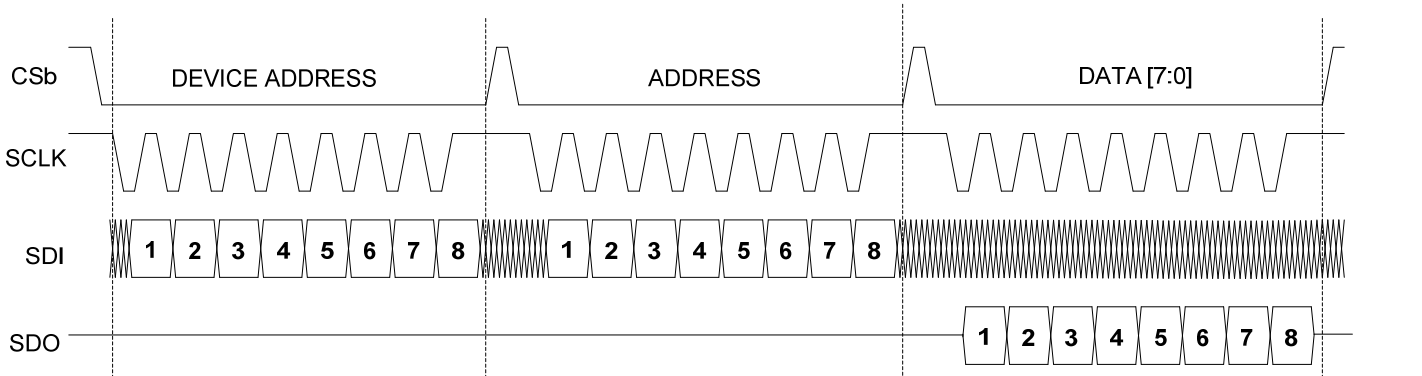

Figure 28: Register read operation through a 8-bit SPI port

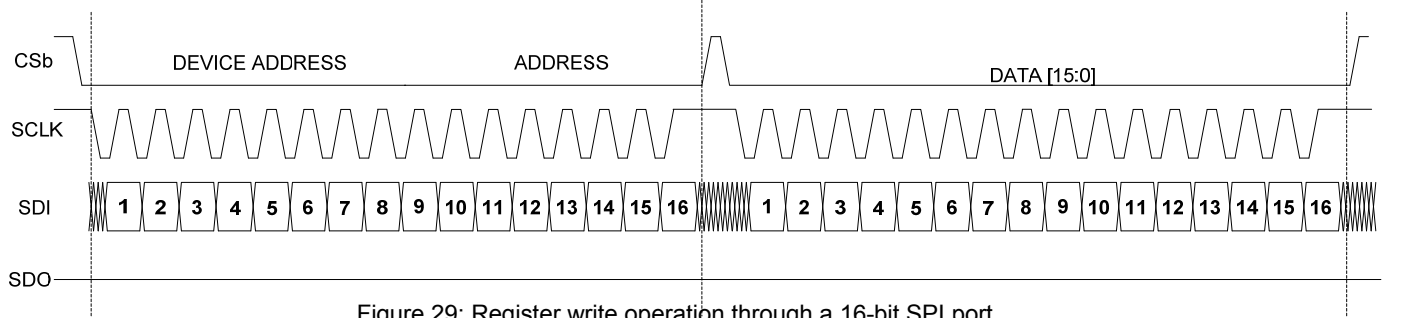

Figure 29: Register write operation through a 16-bit SPI port

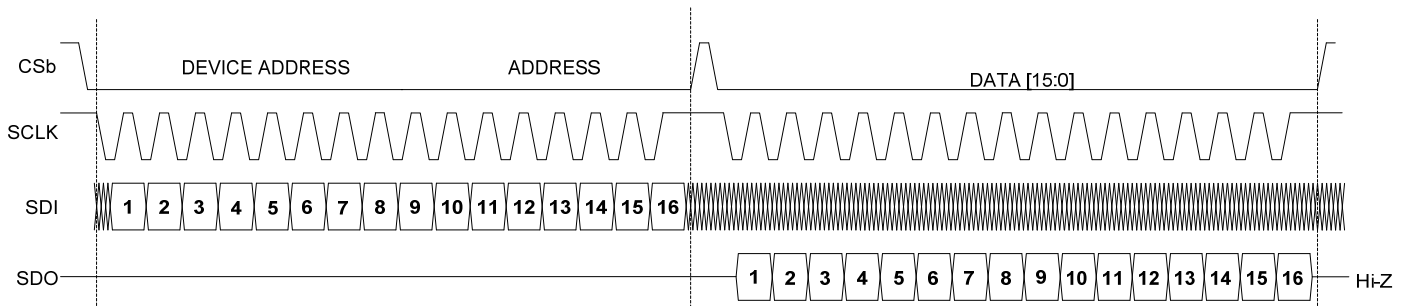

Figure 30: Register read operation through a 16-bit SPI port

12.2.5. SPI DAISY CHAIN

When using multiple N681386/87 devices, SPI programming can be accomplished using a daisy chain architecture which allows all chips to share one CSb and one SCLK. To enable the daisy chain configuration, the DSY pin should be set HIGH. In this configuration the SDO pin will no longer tri-state in order to pass the serial data to the next device in the chain. An internal 16-bit shift register in each device facilitates the daisy chain. After CSb goes LOW, SDI is clocked into this shift register at each rising edge of SCLK. At each falling edge of SCLK the contents of the shift register are shifted to SDO. SDO can then be connected to the SDI of the next chip in the daisy chain sequence. Each device evaluates the data in the internal shift register at the rising edge of CSb. Figure 35 illustrates a three-device daisy chain arrangement.

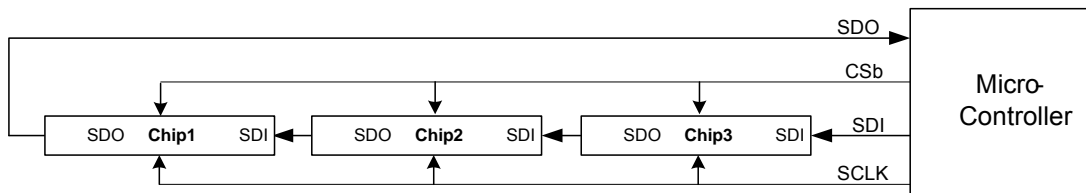

Figure 31: Three Chip Daisy Chain connection

For daisy chain operation, the length for Device address, Register Address and CSb should be 16xD bits, where D is the total number of devices in the daisy chain. Figure below illustrates the Device address, and Register Address structure for three-device daisy chain architecture. Three 16-bit Device address and Register Address words are sent sequentially, the first word for the first device in the daisy chain, the second word for the second device, etc. Device addressing is still enabled during daisy chain mode. Therefore, if a command needs to be ignored an unmatched device address can be sent with the command. If a command needs to be ignored a NOP can be sent with the command by sending a '1' for any bit of C6 to C3.

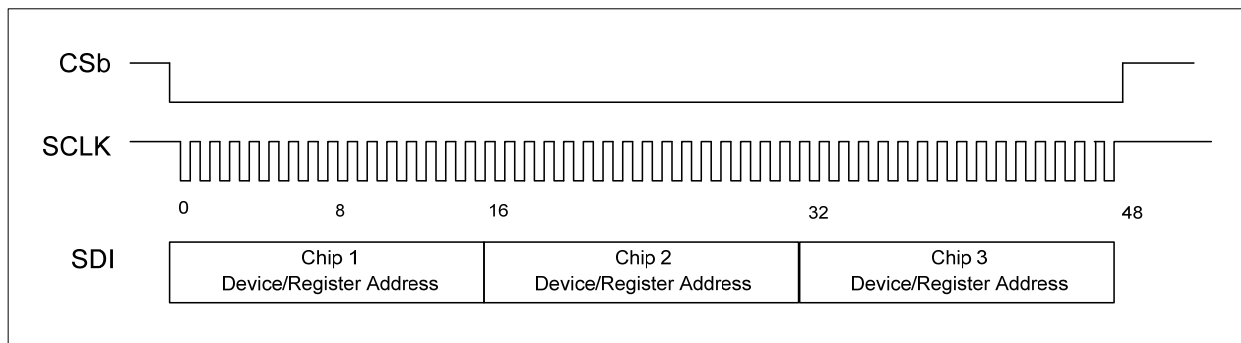

Figure 32: Device/Register Address for Three Device Daisy Chain application

Figure below illustrates the DATA structure for three-device daisy chain architecture. Three 8-bit DATA bytes are sent sequentially, the first byte for the first device in the daisy chain, the second byte for the second device, etc.

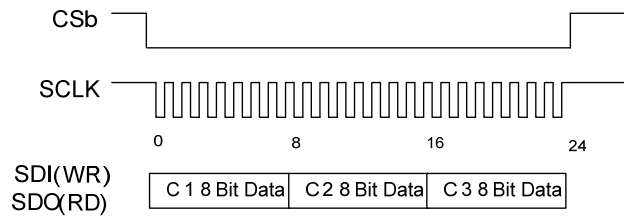

Figure 33: DATA for Three Device Daisy Chain application

12.2.6. SPI BURST MODE

The N681386/87 also supports a burst mode which allows multiple consecutive registers to be written to or read using a single Device address and Register address with BST=1. The complete register address space (256 locations) can be read/ written to using burst mode.

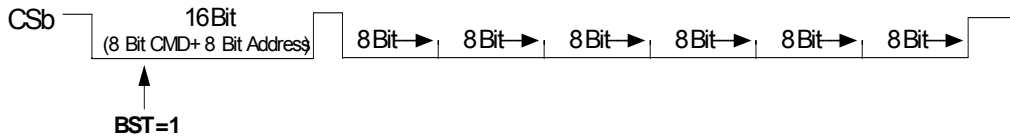

Figure 34: Burst mode operation (BST=1)

The data stored in memory at the next address can be read sequentially by continuing to provide clock pulses. The address is automatically incremented to the next higher address after each byte of data is shifted out. When the highest address is reached, the address counter rolls over to address (0x00) allowing the read cycle to be continued indefinitely.

When the BST bit in Device address is set during a write operation the N681386/87 will accept multiple 8-bit DATA blocks which will be written to sequential address locations beginning with the address specified in Register address. The length of the burst is determined by the Chip Select (CSb). Note that if there is a location within the sequence without a register assignment a dummy byte should be sent at the corresponding location in the DATA sequence.

Similarly during a burst read operation the device will output DATA as long as CSb is LOW. The device will output a dummy byte (0x00) when locations without register assignments are within the sequence. Register bits PCMC:BDAEN[3] address (0x00) and PCMC:BCEN[1] address (0x00) is be used to determine the broadcasting preferences. By default, after a reset, the device will accept all burst write commands without decoding bits C3 to C6. Once the PCMC:BCEN[1] address (0x00) bit is set, the device will only accept burst write data for the channel. Once the PCMC:BDAEN[3] address (0x00) bit is set, the device will only accept burst write data when C3 to C6 are '0'.

12.2.7. SPECIAL READ SEQUENCE FOR 12-BIT WIDE REGISTER

Although N681386/87 has 8-bit wide register map, it includes some additional register bits for accurate ADC monitoring. N681386/87 includes a special SPI Read feature. This read feature allows the user to read the 12-bits wide registers. It can be used in the 8-bits or 16-bits wide register data read mode. One important thing to remember is that BURST Mode cannot be use for 12-bit register read.

12.2.7.1. 12-BIT READ SEQUENCE

Two separate read sequences I required to successfully read 12-bit register. Whether it is 8-bits or 16-bits wide register data N681386/87 still requires two byte read sequence. Selection of the second byte read is shown on one of the above table.

8-bits or 16-bits Data Read sequence for 12-bits ADC monitoring data

■ Sequence Read

- 1st byte Read
 - Device Address bits[2:1] – **00 binary**
 - Register Address any of the ADC monitoring registers
 - The 8 bits[7:0] of the first read data are the bits[11:4] of the 12-bits register

- 2nd byte Read
 - Device Address bits[2:1] – **01 binary**
 - Register Address any of the ADC monitoring registers
 - The 4 MSB bits[7:4] of the second read data are the bits[3:0] of the 12-bits register

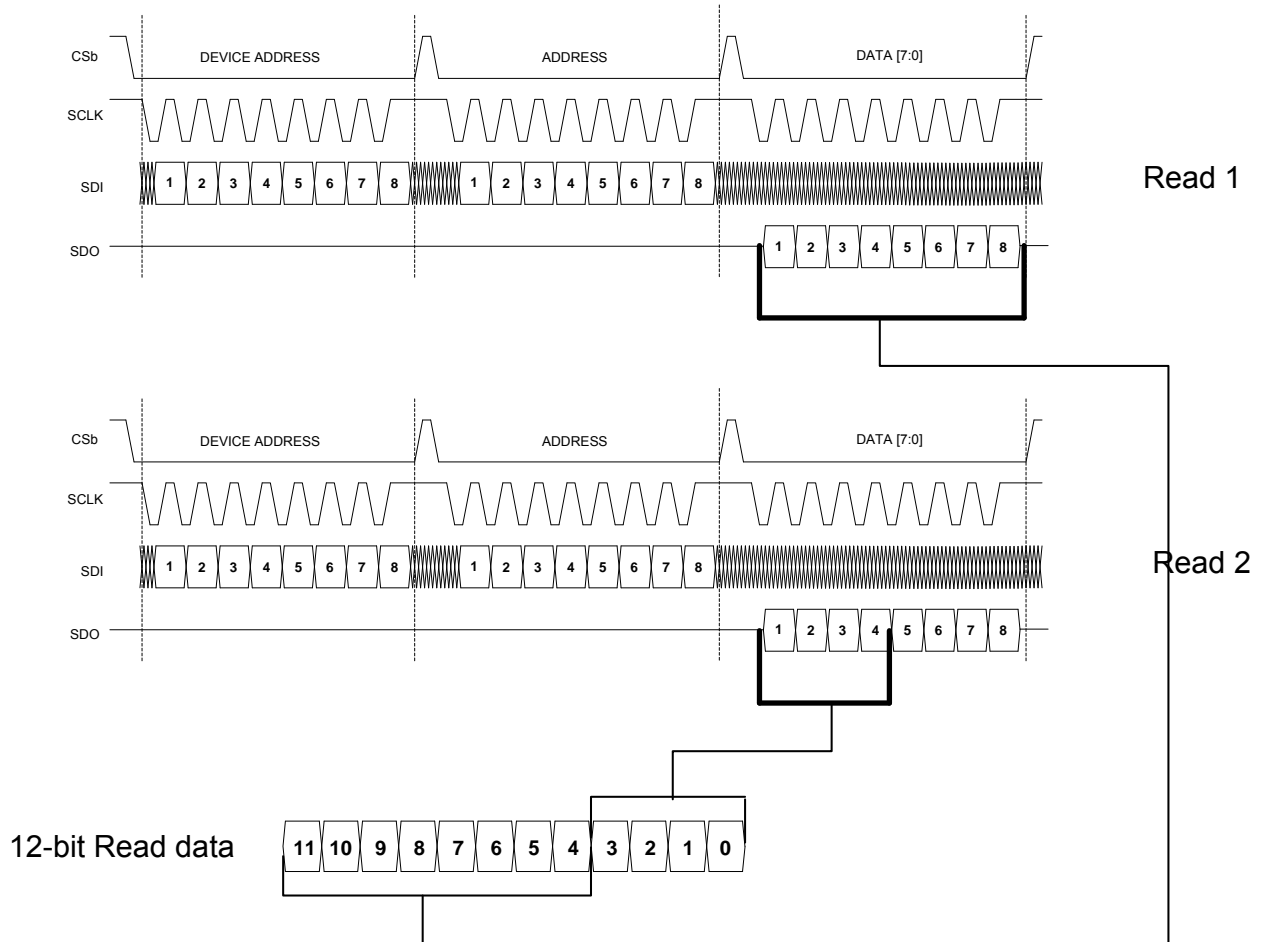

Figure 35: SPI 12-bits Read sequence

12.3. POWER-ON RESET

The following Power-on Reset procedure is recommended for the N681386/87.

- ◆ The Reset pin (RESETb) should be held LOW as power is applied.
This allows logic levels to rise so that all output pins and all registers reach their default values while the system is in reset mode. This process should take less than 100 μ s if the external supply is settled.
- ◆ Clocking should be applied (BCLK and, if necessary, FS)
- ◆ Ensure CSb and SCLK are set HIGH before setting RESETb HIGH
- ◆ Wait at least 400 μ s to ensure the PLL is locked. The status can be read in register PLLS:PL[0] address (0x04)
- ◆ Initialize all appropriate country specific registers and mode registers according to specific operating mode

12.4. INTERRUPT HANDLING

A number of events are capable of generating an interrupt. However, an interrupt signal is generated only if the bit corresponding to that particular interrupt event is enabled in the Interrupt Enable Register. In that case the corresponding bit is set in the Interrupt Status Register. An umbrella Interrupt Vector Register, INTV, indicates which Interrupt Status Registers have bits currently set. This vectoring allows an interrupt service routine to quickly determine which interrupt event has just occurred.

Once the interrupt has been serviced the Interrupt Status Register can be cleared by writing a one to that respective bit. The Interrupt Vector Register INTV bits will be cleared when there are no pending interrupts in the corresponding Interrupt Status Registers

Register Name	Address	Parameter	Description / Range
INTV	0x24	Interrupt Vector Register	Vectors the interrupt location
INT1	0x26	Interrupt Status Register 1	Power Alarms, RING Trip and Loop Closure Interrupts
IE1	0x27	Interrupt Enable Register 1	Enables for Register 1 interrupts
INT2	0x28	Interrupt Status Register 2	FSK, DTMF, RING and Oscillator Interrupts
IE2	0x29	Interrupt Enable Register 2 for	Enables for Register 2 interrupts
INT3	0x2A	Interrupt Status Register 3	Temperature Interrupts
IE3	0x2B	Interrupt Enable Register 3	Enables for Register 3 interrupts

Table 33: Interrupt Registers

13. GENERAL DESCRIPTION FOR N681622 (LINEFEED CIRCUIT)

The N681622 is the first supporting chip of its kind in the Nuvoton's Pro-X line of products. It integrated the high voltage linefeed circuit. It can be used with N681386, N681387, N682386 and N682387. N681622 is designed to reduce substantial board space compared to the existing discrete implementation of the linefeed circuit. The N681622 operates from a 3.3V supply voltages. A small QFN20 package with exposed pad for thermal considerations allows for easy assembly and PCB design.

13.1. FUNCTIONAL DESCRIPTION FOR N681622 (LINEFEED CIRCUIT)

The N681622 integrates the following six transistors of the discrete line driver: QT1, QT2, QT3, QR1, QR2, and QR3. In the following register description there are some references to currents or voltages for these individual transistors. For the N681622 the important transistors are QT1, QT3, QR1, QR3. The following diagram shows a virtual circuit showing the equivalent positions of the these transistors inside the N681622.

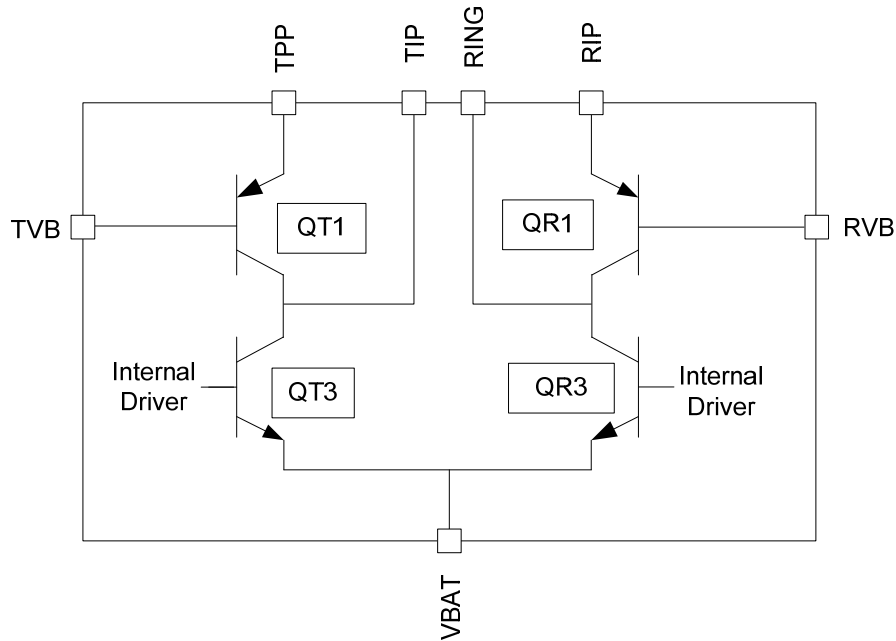

Figure 36: N681622 Equivalent Internal diagram

14. REGISTER DESCRIPTION

Please refer to the SPI command description to read and write instruction. For maximal forward compatibility, it is recommended that “0” be written to reserved bits.

“RES” in the register map means Reserved.

ASYNCR means the device does not require a clock to be able to read or write

12-Bits – specific register has 12-bits

Addr (Dec)	Addr (Hex)	Name	D7	D6	D5	D4	D3	D2	D1	D0	Default (Hex)	R/W	ASYNCR /12Bit		
PCM CONTROL REGISTERS															
0	00	PCMC	CMS[1:0]		BM	GCLK	BDAEN	TRI	RES	EN	00	R/W	ASYNCR (D5-D0)		
1	01	TTLNB	TTSNB[7:0]										00	R/W	ASYNCR
2	02	RTLNB	RTSNB[7:0]										00	R/W	ASYNCR
3	03	TCH	RTSWB[9:8]		TTSWB[9:8]		RTSNB[9:8]		TTSNB[9:8]		50	R/W	ASYNCR		
4	04	PLLS	PLLCM	CLK1544EN	FSRATE	BCFS[3:0] (RO)				PL (RO)	D9	R/W	ASYNCR (D7,D5)		
5	05	PCMFS	BCF[3:0]				IFST	FSS	WBEN	SRES	00	R/W	ASYNCR (D7-D1)		
6	06	SIREV	SIREV[7:0]										00	R	
7	07	DVID	VER[7:0]										C0	R	
8	08	TTLWB	TTSWB[7:0]										00	R/W	ASYNCR
9	09	RTLWB	RTSWB[7:0]										00	R/W	ASYNCR
FSK REGISTERS															
16	10	FSKC	PE	PEN	PTYP	POL	TX	STOP	SPEC	EN	00	R/W			
17	11	FSKTD	FSK[7:0]										00	R/W	
18	12	FSKS	RES					FF	RES	FEP	03	R			
19	13	FSKLCR	RES					GAIN[3:0]			00	R/W			
20	14	FSKTCR	RES					FSKR	FMT	00	R/W				
Diagnostics															
21	15	DIAGCTRL0	FIFOIP	DCREN	ACLPFEN	DCLPFEN	FIFOEN	SIGNED	RES	DIAGEN	00				
22	16	DIAGCTRL1	TRACNEG	ACSEL[2:0]			TRDCNEG	DCSEL[2:0]			00				
23	17	DIAGCTRL2	VHI[7:0]										00		
24	18	DIAGCTRL3	RES	SELT[2:0]			VHI[11:8]				00				
25	19	DIAGCTRL4	VLO[7:0]										00		
26	1A	DIAGCTRL5	DCRDC	DCRAC	DCRRC	RES	VOL[11:8]				00				
27	1B	DIAGCTRL6	TIMER[7:0] (RO)										00		
28	1C	DIAGCTRL7	TMREN	RES		TIMER[12:8] (RO)					00				
29	1D	DIAGCTRL8	DCDP[11:0] (RO)				ACDP[11:0] (RO)				00	RO			
30	1E	DIAGFIFO0	FIFO0[31:0] (RO)										00	RO	
31	1F	DIAGFIFO1	FIFO1[31:0] (RO)										00	RO	
SYSTEM REGISTERS															
32	20	PHF	RES		DACFF[1:0]		ADCFF[1:0]		ADCHP	DACHP	80	R/W			
33	21	LB	DACPOL	ADCPOL	RES	ALP2	ALP1	DLP3	DLP2	DLP1	00	R/W			
34	22	PON	CDCC	RES				DACPP	ADCPP	DCC	01	R/W			
35	23	ILIM	ZCPINV	ZCPEN	RNGGAIN	RIPS	TINS	ILMGAIN	CALTR1	CALTR0	00	R/W			
INTERUPT REGISTERS															
36	24	INTV	RES					IR3C1	IR2C1	IR1C1	00	R/W			
38	26	INT1	PAT3	PAR3	PAT1	PAR1	PAR2	PAT2	LC	RT	00	R/W			
39	27	IE1	PAT3E	PAR3E	PAT1E	PAR1E	PAR2E	PAT2E	LCE	RTE	00	RO			
40	28	INT2	FSKI	DTMFI	RI	RA	O2I	O2A	O1I	O1A	00	R/W			
41	29	IE2	FSKIE	DTMFIE	RIE	RAE	O2IE	O2AE	O1IE	O1AE	00	R/W			
42	2A	INT3	RES				GKDI	RES		TMP	00	R/W			
43	2B	IE3	RES				GKDIE	RES		TMPE	00	R/W			
DTMF REGISTERS															

Addr (Dec)	Addr (Hex)	Name	D7	D6	D5	D4	D3	D2	D1	D0	Default (Hex)	R/W	ASYNC /12Bit		
48	30	DTMFCTRL1	DTMFEN	ADCOSEL	DTMFFDEV[1:0]		DTMFCTC[3:0]				00	R/W			
49	31	DTMFCTRL2	RES							DTMFCLR		00	R/W		
50	32	DTMFCTRL3	RES				DTMFRVDT[3:0]					00	RO		
51	33	DTMFST	RES							DTMFEMT		01	RO		
52	34	DTMFTHRH	DTMFTHR[15:8]									01	R/W		
53	35	DTMFTHRL	DTMFTHR[7:0]									00	R/W		
54	36	DTMFPDT	DTMFPDT[7:0]									00	R/W		
55	37	DTMFADT	DTMFADT[7:0]									00	R/W		
56	38	DTMFACT	DTMFACT[7:0]									00	R/W		
58	3A	DTMFRDT	DTMFRDY	DTMFST	RES		DTMFRDT[3:0]				00	RO			
59	3B	DTMFRFH	DTMFRF[15:8]									00	RO		
60	3C	DTMFRFL	DTMFRF[7:0]									00	RO		
61	3D	DTMFCFH	DTMFCF[15:8]									00	RO		
62	3E	DTMFCFL	DTMFCF[7:0]									00	RO		
LINE REGISTERS															
64	40	APG	RAMP	PRE	VOHZ	RES	ARX[1:0]		ATX[1:0]		00	R/W			
65	41	HB	DACG	ADCG	RES			AHYB[2:0]			1B	R/W			
66	42	VCMR	RES				VCMR[5:0]				00	R/W			
67	43	LAMC	RES							PAA	RGA	LCDA	07	R/W	
68	44	LS	SLS[3:0]				LS[3:0]				00	RO			
69	45	LCL	LGCR	LGCR	LGCM[1:0]	LGCR	RES	ILM[2:0]			00	R/W			
70	46	RTL	RTM	LCM	VBLC	RTDUD	RTDUA	LCDU	RTD	LCD	00	R/W			
71	47	LCDB	LCD[7:0]									00	R/W		
72	48	RTDBA	ARTDI[7:0]									00	R/W		
73	49	PWMT	PT[7:0]									FF	R/W		
74	4A	DDCC	DCOFF[7:0]									76	R/W		
76	4C	OHV	RES	SB	VOH[5:0]						20	R/W			
77	4D	GMV	UBR	RES	VGM[5:0]						02	R/W			
78	4E	VBHV	XBATR	RES	VBATH[5:0]						32	R/W			
79	4F	VBLV	RES			VBATL[5:0]						10	R/W		
80	50	LCDCL	LCDC[7:0]									00	R/W		
81	51	RTDFCLD	ARTDFC[7:0]									00	RO		
82	52	DCHD	ARTDFC[11:8]				LCDC[11:8]				00	RW			
83	53	LCT	RES				LCT[5:0]				00	RO			
84	54	LCTHY	DBTR	LCHYEN	LCTOFF[5:0]						00	R/W			
85	55	RTTA	RES				ARTT[5:0]				00	R/W			
86	56	VOV	RES			TR	VOV[3:0]				00	R/W			
87	57	DCTON	RES				TONDC[4:0]				00	R/W			
94	5E	AMT	AMTEN	AMTSEL	AMTTHR						00	R/W			
95	5F	XBTC	RES	ASQH	CBP	XTBEN	XTBOT[1:0]	XTBA[1:0]		00	R/W				
GROUND KEY DETECTION REGISTERS															
96	60	GKDH	RES				HGKD[5:0]				00	RO			
97	61	GKDL	RES				LGKD[5:0]				00	R/W			
98	62	GKDDT	DTGKD[7:0]									00	R/W		
99	63	GKDFCL	FCGKD[7:0]									02	R/W		
100	64	GKDFCH	GKDEN	RES			FCGKD[11:8]				32	R/W			
101	65	RTDFCLD	DRTDFC[7:0]									10	R/W		
102	66	DCHD	RES				DRTDFC[11:0]				00	R/W			
103	67	RTTD	RES	XRTR	DRTT[5:0]						00	R/W			
104	68	RTDBD	DRTDI[7:0]									00	R/W		
106	6A	XBSDCN	DCNXB[7:0]									00	R/W		
107	6B	XBSDCP	DCPXB[7:0]									00	R/W		
110	6E	LOAD	RES							LOAD		00	R/W		
119	77	DCTR	VTR[7:0]									C8	RO		

Addr (Dec)	Addr (Hex)	Name	D7	D6	D5	D4	D3	D2	D1	D0	Default (Hex)	R/W	ASYNC /12Bit			
MONITOR																
120	78	RTMNT	MNTRT[7:0]									00	RO			
121	79	LCMNT	MNTLC[7:0]									00	RO			
122	7A	MNT5	MNTQ1[7:0] (QT1)									00	RO			
123	7B	MNT7	MNTQ2[7:0] (QR1)									00	RO			
124	7C	MNT9	MNTQ3[7:0] (QR2)									00	RO			
125	7D	MNT11	MNTQ4[7:0] (QT2)									00	RO			
126	7E	MNT13	MNTQ5[7:0] (QR3)									00	RO			
127	7F	MNT15	MNTQ6[7:0] (QT3)									00	RO			
LINE CONTROL REGISTERS																
VOLTAGE REGISTERS																
128	80	BATV	VB[7:0]									02	RO			
129	81	VTIP	VTIP[11:0]									000	RO	12-Bits		
130	82	VRING	VRING[11:0]									000	RO	12-Bits		
131	83	QT3V	QT3V[7:0] (VTVE) (VQT2)									02	RO			
132	84	QR3V	QR3V[7:0] (VRVE) (VQR2)									02	RO			
TRANSISTOR CURRENT REGISTERS																
133	85	QT3I	QT3I[11:0]									005	RO	12-Bits		
134	86	QR3I	QR3I[11:0]									003	RO	12-Bits		
135	87	QT1I	QT1I[11:0]									003	RO	12-Bits		
136	88	QT2I	QT2I[11:0]									003	RO	12-Bits		
137	89	QR1I	QR1I[11:0]									003	RO	12-Bits		
138	8A	QR2I	QR2I[11:0]									003	RO	12-Bits		
LOOP SUPERVISION																
140	8C	LGI	ILG[11:0]									001	RO	12-Bits		
141	8D	LPV	VLP[11:0]									001	RO	12-Bits		
142	8E	TIPI	ITLP[11:0]									002	RO	12-Bits		
143	8F	RINGI	IRLP[11:0]									000	RO	12-Bits		
144	90	LPI	ILP[11:0]									001	RO	12-Bits		
145	91	POL	RES	P2PEN	ILGP	ILPP	IRLPP	ITLPP	VLPP		1A	R/W				
146	92	SCM	SCM[11:0]									02	RO	12-Bits		
147	93	VEQT1	VEQT1[7:0]									00	RO			
148	94	VQT1	VQT1[7:0]									00	RO			
149	95	VEQR1	VEQR1[7:0]									00	RO			
150	96	VQR1	VQR1[7:0]									00	RO			
153	99	TEMP	TS[7:0] (Vtemp)									00	RO			
154	9A	VBGAP	VBC[7:0]									4A	RO			
155	9B	VLPP2P	LPVP2P[11:0]									000	RO	12-Bits		
156	9C	ILPP2P	LPIP2P[11:0]									000	RO	12-Bits		
POWER ALARM LPF POLE REGISTERS																
159	9F	PALCNT	PALCNT[7:0]									00	RO			
160	A0	PALPQ2	Q2C[7:0]									00	R/W			
161	A1	PALPQn	Q1C[7:0]									00	R/W			
162	A2	PALPQ3	Q3C[7:0]									00	R/W			
163	A3	PALPQHn	Q1C[11:8]						Q2C[11:8]						00	R/W
164	A4	PALPQH2	RES	Q3C12	Q1C12	Q2C12	Q3C[11:8]						00	R/W		
165	A5	PATHQ2	Q2TH[7:0]									00	R/W			
166	A6	PATHQn	Q1TH[7:0]									00	R/W			
167	A7	PATHQ3	Q3TH[7:0]									00	R/W			
IMPEDENCE MATCHING REGISTERS																
168	A8	IM1	ZC[3:0]						ZRn[3:0]						00	R/W
169	A9	IM2	RES	ZSW	ZCP[1:0]				ZR2C[3:0]						00	R/W
170	AA	THAT	THAT[7:0]									00	R/W			
171	AB	LCMCNT	LCMCNT[7:0]									00	RO			

Addr (Dec)	Addr (Hex)	Name	D7	D6	D5	D4	D3	D2	D1	D0	Default (Hex)	R/W	ASYNC /12Bit		
172	AC	CC	RES				CBGSW	CTRIM[2:0]			00	RO			
173	AD	OS2RPD	O2RPD[7:0]										00	RO	
CALIBRATION REGISTERS															
175	AF	CAL1	SDAT[3:0]				VBATT[3:0]				79	RO			
176	B0	CAL2	TVTE1[3:0]				SDBT[3:0]				97	RO			
177	B1	CAL3	SCMT[3:0]				RVTE1[3:0]				79	RO			
DC OFFSET REGISTERS															
180	B4	IQTROS	HISENSE	BTVR	ILFDB	DACSFC	RES					00	R/W		
181	B5	PWCT	PWCT[7:0]										00	RO	
182	B6	CAL4	XVRTS[3:0]				XIRTT[1:0]		RES				78	R/W	
tone GENERATION REGISTERS															
192	C0	OSN	RES				O2ZC	O1ZC	O2E	O1E	08			R/W	
193	C1	RMPC	TRAP	LBAC	R1EN	RES	TOR	RES					00	R/W	
OSCILLATOR INITIAL CONDITION & COEFFICIENT REGISTERS															
194	C2	OS1ICL	O1IC[7:0]										00	R/W	
195	C3	OS1ICH	O1IC[15:8]										00	R/W	
196	C4	OS2ICL	O2IC[7:0]										00	R/W	
197	C5	OS2ICH	O2IC[15:8]										00	R/W	
198	C6	OS1CL	O1C[7:0]										00	R/W	
199	C7	OS1CH	O1C[15:8]										00	R/W	
200	C8	OS2CL	O2C[9:2]										00	R/W	
201	C9	OS2CH	O2C[17:10]										00	R/W	
OSCILLATOR ACTIVE & INACTIVE TIME REGISTERS															
202	CA	OS1ATL	O1ON[7:0]										00	R/W	
203	CB	OS1ATH	O1ON[15:8]										00	R/W	
204	CC	OS2ATL	O2ON[7:0]										00	R/W	
205	CD	OS2ATH	O2ON[15:8]										00	R/W	
206	CE	OS1ITL	O1OFF[7:0]										00	R/W	
207	CF	OS1ITH	O1OFF[15:8]										00	R/W	
208	D0	OS2ITL	O2OFF[7:0]										00	R/W	
209	D1	OS2ITH	O2OFF[15:8]										00	R/W	
GENERAL TONE GENERATION REGISTERS															
220	DC	ROFFS	O2C[1:0]			ROS[5:0]						00	R/W		
221	DD	ADCL	ADC[7:0]										00	R/W	
222	DE	DACL	DAC[7:0]										00	R/W	
223	DF	DGH	DAC[11:8]					ADC[11:8]					44	R/W	
DC-DC CONFIGURATION and OTHER FUNCTIONS															
224	E0	ST0L0	RES				ST0L0[3:0]					02	R/W		
225	E1	ST1L0	RES				ST1L0[4:0]					04	R/W		
226	E2	ST2L0	RES				ST2L0[4:0]					06	R/W		
227	E3	ST0L1	RES				ST0L1[3:0]					08	R/W		
228	E4	ST1L1	RES				ST1L1[4:0]					10	R/W		
229	E5	ST2L1	RES				ST2L1[4:0]					19	R/W		
230	E6	SK0L0	SK0L0[7:0]										1F	R/W	
231	E7	SK1L0	RES			SK1L0[5:0]						04	R/W		
232	E8	SK2L0	RES				SK2L0[4:0]					02	R/W		
233	E9	SK0L1	SK0L1[7:0]										1F	R/W	
234	EA	SK1L1	RES			SK1L1[5:0]						04	R/W		
235	EB	SK2L1	RES				SK2L1[4:0]					02	R/W		
236	EC	WM0	RES				WM0[4:0]					08	R/W		
237	ED	WM1	RES				WM1[4:0]					10	R/W		
238	EE	WM2	RES				WM2[4:0]					18	R/W		
239	EF	XSTEP	PWMTc					XS[3:0]					53	R/W	
243	F3	IMRAM	IMDATA										00	R/W	

Addr (Dec)	Addr (Hex)	Name	D7	D6	D5	D4	D3	D2	D1	D0	Default (Hex)	R/W	ASYNC /12Bit		
244	F4	IMDEL	IMHYBDC[3:0]				IMB3PDC[3:0]				00	R/W			
245	F5	IMEN	RES			IMRW	RES	IMEN	IMR1M	IMPM	10	R/W			
246	F6	PCMSCAL	PCMSCAL[7:0]										00	R/W	
247	F7	PCMSCAH	PCMSCAL[15:8]										20	R/W	
248	F8		RES										00	W	
249	F9		RES										00	W	
250	FA		RES										00	W	
251	FB	IMEN	RES						ADCLPFBYP	HBLPFBYP		00	R/W		

Decimal to Hex Conversion

To convert decimal value to hex value divide the decimal number by 16, and write the remainder on the side as the least significant digit. This process is continued by dividing the quotient by 16 and writing the remainder until the quotient is 0. When performing the division, the remainders which will represent the hex equivalent of the decimal number are written beginning at the least significant digit (right) and each new digit is written to the next more significant digit (the left) of the previous digit. Consider the number 175 decimal.

Division	Quotient	Remainder	Hex Number
175 / 16	10 = A	15 = F	AF

N681386/87 includes some bits that can be written without the PLL running while some bits requires the PLL running for the write to be effective. Any register that states the **ASYNC** bits means that specific DO NOT require the PLL running for the write to be effective.

14.1. PCM CONTROL REGISTERS

14.1.1. PCM CONTROL REGISTER

Addr.	Name	D7	D6	D5	D4	D3	D2	D1	D0	Default	Async (D0 - D5)
0x00	PCMC	CMS[1:0]		BM	GCLK	BDAEN	TRI	RES	EN	0x00	

The following table explains the PCM control register bits.

Bit Location	Bit Description	Bit Name	Bit Value	
			0	1
0	PCM path including digital receive path	EN	Disable	Enable
2	Tri-state PCMT LSB	TRI	Positive edge of BCLK	Negative edge of BCLK
3	Burst Device Address decode enable	BDAEN	All Devices in Parallel	Single Device
4	GCI Clock Format (per data bit)	GCLK	1 BCLK	2 BCLK
5	Must be set appropriate to PCMC:CMS selection	BM	8-bit mode	16-bit mode

There are three different CODEC Modes to choose from and they are as follows:

CODEC MODE SELECTION		
CMS1	CMS0	Mode
0	0	A-Law
0	1	u-Law
1	0	Linear
1	1	Reserved

14.1.2. RECEIVE/TRANSMIT TIMESLOT (WIDEBAND AND NARROWBAND)

Addr.	Name	D7	D6	D5	D4	D3	D2	D1	D0	Default	Async
0x01	TTLNB	TTSNB[7:0]								0x00	
0x02	RTLNB	RTSNB[7:0]								0x00	
0x03	TCH	RTSWB[9:8]		TTSWB[9:8]		RTSNB[9:8]		TTSNB[9:8]		0x50	

Transmit and receive timeslot are expressed in number of BCLK cycles in a 10-bit word. For Narrowband, Transmit Timeslot Start, TTSNB[9:0], determines the start point for the timeslot on the PCM interface for data in the transmit direction and the Receive Timeslot Start, RTSNB[9:0], determines the start point for the timeslot on the PCM interface for data in the receive direction. Timeslot Channel High, TCH address (0x03) bits are the two most significant bits of the 10-bit word for both transmit and receive timeslot, TCH:RTSWB[9:8] and TCH:TTSWB[9:8] for Wideband and TCH:RTSNB[9:8] and TCH:TTSNB[9:8] for Narrowband.

14.1.3. PLL STATUS REGISTER

Addr.	Name	D7	D6	D5	D4	D3	D2	D1	D0	Default	Async (D7, D5)
0x04	PLLS	PLLCM	CLK1544EN	FSRATE	BCFS[3:0] (RO)			PL (RO)		0xD9	

PL[0] and BCFS[4:1] are status bits which means they are **READ ONLY** bits in this register. Any write to these bits will be ignored. FSRATE[5], CLK1544EN[6], and PLLM[7] are READ/WRITE bits.

Bit Location	Bit Description	Bit Name	Bit Value	
			0	1
0	PLL Lock Status (RO)	PL	Not Locked	Locked
5	Frame Sync Rate	FSRATE	8kHz	16kHz
6	Enable clock 1.544MHz	CLK1544EN	Disabled	Enabled

With an external 8 kHz Frame Sync set (PCMFS:FSS=0), PLL Bit Clock Frequency Status, BCFS[3:0] bits will show the value of BCLK according to the following table. Not all clocks are supported by 16KHz frame sync [*].

Bit Clock Frequency				
BCFS[3]	BCFS[2]	BCFS[1]	BCFS[0]	BCLK(kHz)
0	0	0	0	256
0	0	0	1	512
0	0	1	0	768
0	0	1	1	1000*
0	1	0	0	1024
0	1	0	1	1152
0	1	1	0	1536
0	1	1	1	1544*
1	0	0	0	2000
1	0	0	1	2048
1	0	1	0	4000
1	0	1	1	4096
1	1	0	0	8000
1	1	0	1	8192
1	1	1	0	NA
1	1	1	1	

DC/DC CLK Mode		DC-DC Clock Type
PLLCM[7]	PON:CDCC[7] (Addr – 0x22)	
0	0	$\frac{1}{13.824\text{MHz}}$
0	1	$\frac{1}{27.648\text{MHz}}$
1	0	
1	1	

14.1.4. PCM FREQUENCY SETTING REGISTER

Addr.	Name	D7	D6	D5	D4	D3	D2	D1	D0	Default	Async (D7- D1)
0x05	PCMFS	BCF[3:0]			IFST	FSS	WBEN	SRES	0x00		

The following table explains the PCM Frequency Setting register bits.

Bit Location	Bit Description	Bit Name	Bit Value	
			0	1
0	Soft Reset	SRES	Disable	Enable
1	Band Select	WBEN	FS = 8kHz (Narrowband)	FS = 16kHz (Wideband)
2	Frame Sync Source	FSS	External	Internal
3	Internal Frame Sync Type	IFST	Short (fixed width 1 BCLK)	Long (fixed width 8 BCLK)

When an internal 8 kHz Frame Sync is used (PCMFS:FSS=1) these bits should be programmed with the value of BCLK Frequency, BCFS[3:0], according to the following table.

Bit Clock Frequency				
BCF [4]	BCF [3]	BCF [2]	BCF [1]	BCLK (Hz)
0	0	0	0	256
0	0	0	1	512
0	0	1	0	768
0	0	1	1	1000
0	1	0	0	1024
0	1	0	1	1152
0	1	1	0	1536
0	1	1	1	1544
1	0	0	0	2000
1	0	0	1	2048
1	0	1	0	4000
1	0	1	1	4096
1	1	0	0	8000
1	1	0	1	8192
1	1	1	0	NA
1	1	1	1	

14.1.5. SILICON VERSION ID REGISTER (READ ONLY)

Addr.	Name	D7	D6	D5	D4	D3	D2	D1	D0	Default
0x06	SIREV	SIREV[7:0]								0xEF

Silicon revision ID Register is a **READ ONLY** register.

14.1.6. DEVICE VERSION ID REGISTER (READ ONLY)

Addr.	Name	D7	D6	D5	D4	D3	D2	D1	D0	Default
0x07	DVID	VER[7:0] (RO)								NA

Device Version ID Register is a **READ ONLY** register.

Device	VER[7:0]	Condition
N681386	0x01	
N681387	0x01	WBAND Pin = GND
N681387	0x09	WBAND Pin = VDD

14.1.7. TIMESLOT (WIDEBAND)

Addr.	Name	D7	D6	D5	D4	D3	D2	D1	D0	Default	Async
0x08	TTLWB	TTSWB[7:0]								0xC0	
0x09	RTLWB	RTSWB[7:0]								0xC0	

Transmit and receive timeslot are expressed in number of BCLK cycles in a 10-bit word. For Wideband, Transmit Timeslot Start, TTSWB[9:0], determines the start point for the timeslot on the PCM interface for data in the transmit direction and the Receive Timeslot Start, RTSWB[9:0], determines the start point for the timeslot on the PCM interface for data in the receive direction. The two most significant bits of the 10-bit word are located on register TCH address (0x03).

14.2. FSK REGISTERS

14.2.1. FSK CONTROL REGISTER

Addr.	Name	D7	D6	D5	D4	D3	D2	D1	D0	Default
0x10	FSKC	PE	PEN	PTYP	POL	TX	STOP	SPEC	EN	0x00

The following table explains the FSK Control Register bits.

Bit Location	Bit Description	Bit Name	Bit Value	
			0	1
0	FSK Encoder	EN	Disable	Enable
1	FSK Specification	SPEC	Bell 202	ITU-T V.23
2	Number of STOP bits	STOP	1 Stop bit	2 Stop bits
3	FSK Encoder start to transmit data from FSK FIFO	TX	Stop Transmission	Start Transmission
4	FSK bit stream polarity	POL	Non-inverted	Inverted
5	Parity Bit Type	PTYP	Even parity	Odd parity
6	Parity Bit Enable	PEN	Disable	Enable
7	FSK Package Format	PE	Disable	Enable

FSK Package Format automatically amends a 'start bit' (Space) to the head of the FSK transmit data and one or two 'stop bits' (Mark) to the end, depending on programming of FSKC:STOP. "Res" in the register map means Reserved.

	Bell 202	ITU-T V.23
Mark '1'	1200 Hz	1300 Hz
Space '0'	2200 Hz	2100 Hz

14.2.2. FSK TRANSMIT REGISTER

Addr.	Name	D7	D6	D5	D4	D3	D2	D1	D0	Default
0x11	FSKTD	FSK[7:0]								0x00

FSK Transmit Register, FSK[7:0], is a WRITE ONLY register. Data written to this register will be placed into the Internal FIFO for transmission. Note: Reading this register will always give 0x00 as data.

14.2.3. FSK STATUS REGISTER (READ ONLY)

Addr.	Name	D7	D6	D5	D4	D3	D2	D1	D0	Default
0x12	FSKS	RES					FF (RO)	RES	FEP (RO)	0x03

“RES” in the register map means reserved bit(s).

FSK Status Register is a **READ ONLY** register. The following table explains the FSK Status Register bits.

Bit Location	Bit Description	Bit Name	Bit Value	
			0	1
0	FSK FIFO Empty Pending	FEP	FSK FIFO not empty (Last set of bit stream finished transmitting)	FSK FIFO is empty
2	FSK FIFO Full	FF	FSK FIFO not Full	FIFO Full

14.2.4. FSK LCR REGISTER

Addr.	Name	D7	D6	D5	D4	D3	D2	D1	D0	Default
0x13	FSKLCR	RES				GAIN[3:0]				0x00

“RES” in the register map means reserved bit(s).

The gain level is specified in linear values and referenced to the maximum linear PCM level (+3.14 dBm0). The following table contains the adjusted levels and the attenuated value of the correspondent maximum PCM level.

FSK Encoder output signal level				Attenuation to max PCM level
GAIN3	GAIN2	GAIN1	GAIN0	
0	0	0	0	-∞
0	0	0	1	-23.512
0	0	1	0	-17.499
0	0	1	1	-13.978
0	1	0	0	-11.48
0	1	0	1	-9.542
0	1	1	0	-7.956
0	1	1	1	-6.617
1	0	0	0	-5.458
1	0	0	1	-4.434
1	0	1	0	-3.52
1	0	1	1	-2.692
1	1	0	0	-1.937
1	1	0	1	-1.242
1	1	1	0	-0.599
1	1	1	1	0

14.2.5. FSK TCR REGISTER

Addr.	Name	D7	D6	D5	D4	D3	D2	D1	D0	Default
0x14	FSKTCR	<i>RES</i>						FSKR	FMT	0x00

“RES” in the register map means reserved bit(s).

Bit Location	Bit Description	Bit Name	Bit Value	
			0	1
0	Fast Mode	FMT	Disabled	Enabled
1	FSK Route	FSKR	Output	Not Output

14.3. DIAGNOSTIC REGISTERS

14.3.1. DIAGNOSTIC CONTROL 0

Addr	Name	D7	D6	D5	D4	D3	D2	D1	D0	Default
0x15	DIAGCTRL0	FIFOIP	DCREN	ACLPFEN	DCLPFEN	FIFOEN	SIGNED	RES	DIAGEN	0x00

Bit Location	Bit Description	Bit Name	Bit Value	
			0	1
0	Enable Diagnostic Mode	DIAGEN	Disabled	Enabled
2	Converts unsigned Source Register data to signed data	SIGNED	Disabled	Enabled
3	Enable DIAGFIFO0 / DIAGFIFO1 FIFO Structure.	FIFOEN	Disabled	Enabled
4	Enable Low pass filter in the DC path. The DC Path LPF utilizes the Loop Closure Detect LPF and is programmed in LCDCL: LCDCL[11:0].	DCLPFEN	Disabled	Enabled
5	Enable Low pass filter in the AC path. The AC Path LPF utilizes the AC Ring Trip Detect LPF and is programmed in RTDFCLD:ARTDFC[11:0].	ACLPFEN	Disabled	Enabled
6	Enable DC Removal function in the AC path	DCREN	Disabled	Enabled
7	Determines Data routed to DIAGFIFO0 / DIAGFIFO1 FIFO Structure DIAGCTRL0:DIAGEN must be set. NOTE: DIAGCTRL0:FIFOEN will be turned on automatically if ADC PCM Data is selected.	FIFOIP	DC/AC Diagnostics Output	ADC PCM data

14.3.2. DIAGNOSTIC CONTROL 1

Addr.	Name	D7	D6	D5	D4	D3	D2	D1	D0	Default
0x16	DIAGCTRL1	TRACNEG	ACSEL[2:0]		TRDCNEG	DCSEL[2:0]				0x00

Bit Location	Bit Description	Bit Name	Bit Value	
			0	1
3	VTIP, VRING and SCM are forced to negative values when selected on the DC diagnostics path.	TRDCNEG	Disabled	Enabled
7	VTIP, VRING and SCM are forced to negative values when selected on the AC diagnostics path.	TRACNEG	Disabled	Enabled

NOTE: Some diagnostic operations required signed operation, for example: DC removal.

ACSEL[6:4]: Select source register for the AC path diagnostics

DCSEL[2:0]: Select source register for the DC path diagnostics

Select AC/DC source for Diagnostics			
ACSEL2 DCSEL2	ACSEL1 DCSEL1	ACSEL0 DCSEL0	Source Register
0	0	0	VTIP
0	0	1	VRING
0	1	0	LPV
0	1	1	SCM
1	0	0	TIPI
1	0	1	RINGI
1	1	0	LPI
1	1	1	LGI

14.3.3. DIAGNOSTIC CONTROL 2, 3, 4, AND 5

Addr.	Name	D7	D6	D5	D4	D3	D2	D1	D0	Default
0x17	DIAGCTRL2	VHI[7:0]								0x00
0x18	DIAGCTRL3	RES	SELT[2:0]			VHI[11:8]			0x00	
0x19	DIAGCTRL4	VLO[7:0]								0x00
0x1A	DIAGCTRL5	DCRDC	DCRAC	DCRRC	RES	VLO[11:8]			0x00	

Select MADC source for timing measurement.			
SELT2	SELT1	SELT0	Source Register
0	0	0	VTIP
0	0	1	VRING
0	1	0	LPV
0	1	1	SCM
1	0	0	TIPI
1	0	1	RINGI
1	1	0	LPI
1	1	1	LGI

VHI[11:0]: Determines V_{HI} for DIACNTRL:TIMER[12:0] measurement.

Range, Step Size and number of valid bits same as Source Register determined by SELT.

VLO[11:0]: Determines V_{LO} for DIACNTRL:TIMER[12:0] measurement.

Range, Step Size and number of valid bits same as Source Register determined by SELT.

Bit Location	Bit Description	Bit Name	Bit Value	
			0	1
5	DC Removal RC Time Constant	DCRRC	1.25/64ms	1.25/32ms
6	DC Removal Accelerated Convergence.	DCRAC	Disable	Enable
7	Enable DC Removal output to DC Path LPF in addition to the normal connection to the AC Path LPF DIACNTRL0:DCREN must be set.	DCRDC	Disable	Enable

Notes:

- When enabled DC Removal is able to estimate the DC level of a selected source data and pass an AC only signal to the AC Path LPF.
- When DC Removal is enabled both DIAGCTRL5:TRDCNEG and DIAGCTRL5:TRACNEG need to be turned on if VTIP or VRING or SCM are selected as the source register.

14.3.4. DIAGNOSTIC CONTROL 6 AND 7 (READ ONLY)

Addr.	Name	D7	D6	D5	D4	D3	D2	D1	D0	Default
0x1B	DIAGCTRL6	TIMER[7:0] (RO)								0x00
0x1C	DIAGCTRL7	TMREN	RES	TIMER[12:8] (RO)						

TIMER[12:0] are status bits which means they are **READ ONLY** bits in this register. Any write to these bits will be ignored. TMREN[5] is READ/WRITE bit.

Bit(s) Location	Bit Description	Bit Name	Bit Value	
			0	1
7	Capacitor Charging Timer	TMREN	Reset Timer - It will increase by at the rate of 800hz when the monitored source is between VLO and VHI.	The timer will accumulate the time when the voltage of the selected source (by SELT) falls between VLO and VHI.

Capacitor Charging Timer			
TMREN[7] (0x1C)			
	Minimum	Maximum	Increment
Range	0 ms	10.24 s	1.25 ms

14.3.5. DIAGNOSTIC CONTROL 8 (READ ONLY)

Addr.	Name	D7	D6	D5	D4	D3	D2	D1	D0	Default
0x1D	DIAGCTRL8	DCDP[7:0] (RO)								00
		RES				DCDP[11:8] (RO)				
		ACDP[7:0] (RO)								00
		RES				ACDP[11:8] (RO)				

DCDP[11:0]: DC Diagnostic Path Output

ACDP[11:0]: AC Diagnostic Path Output

NOTE: This register is structured to be read in 4 byte burst

14.3.6. DIAGNOSTIC FIFO 0 AND FIFO1 (READ ONLY)

Addr.	Name	D7	D6	D5	D4	D3	D2	D1	D0	Default
0x1E	DIAGFIFO0	FIFO0[7:0] (RO)								00
		FIFO0[15:8] (RO)								
		FIFO0[23:16] (RO)								00
		FIFO0[31:24] (RO)								
0x1F	DIAGFIFO1	FIFO1[7:0] (RO)								00
		FIFO1[15:8] (RO)								
		FIFO1[23:16] (RO)								00
		FIFO1[31:24] (RO)								

DIAGFIFO0 and DIAGFIFO1 are structured as Dual FIFO Structures. Each FIFO has 16 entries, each entry structured as a 4 byte structure illustrated above. When one FIFO is full an interrupt is generated and diagnostic data is collected in the alternative FIFO. In Diagnostic Mode (DIAGCTRL0:DIAGEN) DIAGFIFO0 uses the Ring Trip Detect Interrupt mechanism and DIAGFIFO1 uses the Loop Closure Detect Interrupt mechanism.

When DIAGCTRL0:FOFIP[7] is set to 0, DIAGFIFO0 and DIAGFIFO1 are used to store DC Diagnostic Path and AC Path Output Data

- FIFOn[15:0], n=0,1 contains DCDP[11:0]: DC Diagnostic Path Output in the lower 12 bits
- FIFOn[31:16], n=0,1 contains ACDP[11:0]: AC Diagnostic Path Output in the lower 12 bits
- NOTE: DC Diagnostic Path and AC Path Data is input to each FIFO at 800 Hz.

When DIAGCTRL0:FOFIP[7] is enabled DIAGFIFO0 and DIAGFIFO1 are used to store ADC PCM Data

- FIFOn[15:0], n=0,1 contains 16-bit ADC PCM data
 - FIFOn[31:16], n=0,1 is not output
- In this case the Maximum burst read is 32 bytes per FIFO.
- NOTE: PCM Data is input to each FIFO at the sampling frequency (Wideband or Narrowband).

14.4. SYSTEM REGISTERS

14.4.1. PCM HPF (HIGH PASS FILTER)

Addr.	Name	D7	D6	D5	D4	D3	D2	D1	D0	Default
0x20	PHF	DACL P	RES	DACFF[1:0]		ADCFF[1:0]		ADCHP	DACHP	0x80

“RES” in the register map means reserved bit(s).

Bit Location	Bit Description	Bit Name	Bit Value	
			0	1
0	PCM Transmit HPF (DAC)	DACHP	Enable	Disable
1	PCM Receive HPF (ADC)	ADCHP	Enable	Disable
7	LPF for Wideband (DAC)	DACL P	Disable	Enable

High Pass Filter Select DAC		
DACFF [5]	DACFF [4]	DAC HPF Select (Hz)
0	0	20
0	1	40
1	0	80
1	1	160

High Pass Filter Select ADC		
ADCFF [3]	ADCFF [2]	ADC HPF Select (Hz)
0	0	20
0	1	40
1	0	80
1	1	160

High pass filter cutoff is only programmable in the Wideband mode.

14.4.2. LOOP BACK CONTROL REGISTER

Addr.	Name	D7	D6	D5	D4	D3	D2	D1	D0	Default
0x21	LB	DACPOL	ADCPOL	RES	ALP2	ALP1	DLP3	DLP2	DLP1	0x00

“RES” in the register map means reserved bit(s).

The following table explains the Loop Back Control Register bits.

Bit Location	Bit Description	Bit Name	Bit Value	
			0	1
0	Digital loop back (D/A to A/D)	DLP1	Disable	Enable
1	Digital loop back (LP interpolation filter to LP decimation filter)	DLP2	Disable	Enable
2	Digital loop back (A/u law expander to A/u law compander)	DLP3	Disable	Enable
3	Analog Loop back 1	ALP1	Disable	Enable
4	Analog Loop back 2	ALP2	Disable	Enable
6	Invert ADC input Polarity	ADCPOL	Disable	Enable
7	Invert DAC Output Polarity	DACPOL	Disable	Enable

14.4.3. POWER ON

Addr.	Name	D7	D6	D5	D4	D3	D2	D1	D0	Default
0x22	PON	CDCC	<i>RES</i>				DACPP	ADCPP	DCC	0x01

“RES” in the register map means reserved bit(s). The following table explains the Loop Back Control Register bits.

Bit Location	Bit Description	Bit Name	Bit Value	
			0	1
0	DC/DC Power Control Circuitry	DCC	DCDC On	DCDC OFF
1	A/D Power Path	ADCPP	Disable	Enable
2	DAC Power Path	DACPP	Disable	Enable

DC/DC CLK Mode		DC-DC Clock Type
PLLS:PLLCM[7] (Addr: 0x04)	CDCC[7]	
0	0	$\frac{1}{13.824\text{MHz}}$
0	1	$\frac{1}{27.648\text{MHz}}$
1	0	
1	1	

This table gives the PLL Period.

14.4.4. LINEFEED TRIM

Addr	Name	D7	D6	D5	D4	D3	D2	D1	D0	Default
0x23	ILIM	ZCPINV	ZCPEN	RNGGAIN	RIPS	TINS	ILMGAIN	CALTR1	CALTR0	0x00

CALIBRATION STATE CURRENT ADJUST		
CALTR1	CALTR0	Current
0	0	20mA
0	1	19.6mA
1	0	19.4mA
1	1	20.4mA

Bit Location	Bit Description	Bit Name	Bit Value	
			0	1
2	Ring Limiting Gain Adjust strength of Ring limiting Impacts noise	ILIMGAIN	Default	2 x default
3	Idle State Battery Current	TINS	Default current	Low current
4	Idle State Battery Current Stops RIP in idle for lower power	RIPS	Default current	Low current
5	Increase Ring feedback gain in idle and Ring state for more accuracy	RNGGAIN	Default	High gain
6	Line Capacitor Compensation	ZCPEN	Disabled	Enabled
7	Line Capacitor Compensation	ZCPINV	Subtract	Add

14.5. INTERRUPT REGISTERS

14.5.1. INTERRUPT VECTOR LOW (READ ONLY)

Addr.	Name	D7	D6	D5	D4	D3	D2	D1	D0	Default	
0x24	INTV	<i>RES</i>					IR3C1 (RO)	IR2C1 (RO)	IR1C1 (RO)		0x00

“RES” in the register map means reserved bit(s).

Interrupt Vector Register is a **READ ONLY** register. Each bit in this register will be cleared when there are no pending interrupts reported in the corresponding interrupt status registers.

Bit Location	Bit Description	Bit Name	Bit Value	
			0	1
0	Interrupt Vector 1 Low	IR1C1	No INT	INT1
1	Interrupt Vector 2 Low	IR2C1	No INT	INT2
2	Interrupt Vector 3 Low	IR3C1	No INT	INT3

14.5.2. INTERRUPT STATUS REGISTER 1

Addr.	Name	D7	D6	D5	D4	D3	D2	D1	D0	Default
0x26	INT1	PAT3	PAR3	PAT1	PAR1	PAR2	PAT2	LC	RT	0x00

This register displays all the Power Alarm and the Loop Closure interrupt of the device. A pending interrupt is represented by a HIGH “1” in the respective bit. Writing 1 to that respective bit clears the pending interrupt.

Bit Location	Bit Description	Bit Name	Bit Value	
			0	1
0	RING Trip	RT	No INT	INT
1	Loop Closure	LC	No INT	INT
2	Power Alarm QR2	PAT2	No INT	INT
3	Power Alarm QT2	PAR2	No INT	INT
4	Power Alarm QT1	PAR1	No INT	INT
5	Power Alarm QR1	PAT1	No INT	INT
6	Power Alarm QR3	PAR3	No INT	INT
7	Power Alarm QT3	PAT3	No INT	INT

14.5.3. INTERRUPT ENABLE REGISTER 1

Addr	Name	D7	D6	D5	D4	D3	D2	D1	D0	Default
0x27	IE1	PAT3E	PAR3E	PAT1E	PAR1E	PAR2E	PAT2E	LCE	RTE	0x00

This register enables all the Power Alarm and the Loop Closure interrupt of the device. An interrupt can be enabled by writing a HIGH “1” in the respective interrupt bit.

Bit Location	Bit Description	Bit Name	Bit Value	
			0	1
0	RING Trip	RTE	Masked	Enabled
1	Loop Closure	LCE	Masked	Enabled
2	Power Alarm QR2	PAT2E	Masked	Enabled
3	Power Alarm QT2	PAR2E	Masked	Enabled
4	Power Alarm QT1	PAR1E	Masked	Enabled
5	Power Alarm QR1	PAT1E	Masked	Enabled
6	Power Alarm QR3	PAR3E	Masked	Enabled
7	Power Alarm QT3	PAT3E	Masked	Enabled

14.5.4. INTERRUPT STATUS REGISTER 2

Addr.	Name	D7	D6	D5	D4	D3	D2	D1	D0	Default
0x28	INT2	FSKI	DTMFI	RI	RA	O2I	O2A	O1I	O1A	0x00

Bit Location	Bit Description	Bit Name	Bit Value	
			0	1
0	Oscillator 1 Active Timer	O1A	No INT	INT Pending
1	Oscillator 1 Inactive Timer	O1I	No INT	INT Pending
2	Oscillator 2 Active Timer	O2A	No INT	INT Pending
3	Oscillator 2 Inactive Timer	O2I	No INT	INT Pending
4	Ringling Active Timer	RA	No INT	INT Pending
5	Ringling Inactive Timer	RI	No INT	INT Pending
6	DTMF Initialize	DTMFI	No INT	INT Pending
7	FSK Interrupt occurs when the FSK FIFO is empty	FSKI	No INT	INT Pending

14.5.5. INTERRUPT ENABLE REGISTER 2

Addr.	Name	D7	D6	D5	D4	D3	D2	D1	D0	Default
0x29	IE2	FSKIE	DTMFIE	RIE	RAE	O2IE	O2AE	O1IE	O1AE	0x00

Bit Location	Bit Description	Bit Name	Bit Value	
			0	1
0	Oscillator 1 Active Timer	O1AE	Masked	Enabled
1	Oscillator 1 Inactive Timer	O1IE	Masked	Enabled
2	Oscillator 2 Active Timer	O2AE	Masked	Enabled
3	Oscillator 2 Inactive Timer	O2IE	Masked	Enabled
4	Ringling Active Timer	RAE	Masked	Enabled
5	Ringling Inactive Timer	RIE	Masked	Enabled
6	DTMF Inactive Timer	DTMFIE	Masked	Enabled
7	FSK Enable	FSKIE	Masked	Enabled

14.5.6. INTERRUPT STATUS REGISTER 3

Addr.	Name	D7	D6	D5	D4	D3	D2	D1	D0	Default
0x2A	INT3	<i>RES</i>				GKDI	<i>RES</i>		TMP	0x00

“RES” in the register map means reserved bit(s).

This register displays the status of the dice Temperature interrupt of the device. A pending interrupt is represented by a HIGH “1” in the respective bit. Writing 1 to that respective bit clears the pending interrupt.

Bit Location	Bit Description	Bit Name	Bit Value	
			0	1
0	Die Temperature Interrupt	TMP	No INT	INT Pending
3	Ground Key Detection Interrupt	GKDI	No INT	INT Pending

14.5.7. INTERRUPT ENABLE REGISTER 3

Addr.	Name	D7	D6	D5	D4	D3	D2	D1	D0	Default
0x2B	IE3	<i>RES</i>				GKDIE	<i>RES</i>		TMPE	0x00

“RES” in the register map means reserved bit(s).

This register enables the dice Temperature interrupt of the device. An interrupt can be enabled by writing a HIGH “1” in the respective interrupt bit. The following table explains the Interrupt Enable Register 1 bits.

Bit Location	Bit Description	Bit Name	Bit Value	
			0	1
0	Temperature Interrupt Enable	TMPE	Masked	Enabled
3	Ground Key Detection Interrupt Enable	GKDIE	Masked	Enabled

14.6. DTMF DETECTION REGISTER

14.6.1. DTMF CONTROL 1

Addr.	Name	D7	D6	D5	D4	D3	D2	D1	D0	Default
0x30	DTMFC1	DTMFEN	ADCOSEL	DTMFFDEV	DTMFTC				0x00	

ADC output is the signal from ADC coming to DTMF decode. Therefore, the ADC Select bit select either the ADC or PCM input to the DTMF decode. When DTMFTC[3:0] bits are set to larger values, DTMF detector needs more time to decode the DTMF signal but the numerical precision is greater.

Bit Location	Bit Description	Bit Name	Bit Value	
			0	1
6	ADC Output Select	ADCOSEL	ADC output comes from ADC. (Receive path)	ADC output comes from PCM. (Transmit path)
7	DTMF Enable	DTMFEN	Disabled	Enabled

DTMF Frequency Deviation		
DTMFFDEV[5]	DTMFFDEV[4]	Deviation (%)
0	0	1.5
0	1	2.5
1	0	3.0
1	1	3.5

Time constant used for DTMF frequency estimation				
DTMFTC3	DTMFTC2	DTMFTC1	DTMFTC0	Time Constant
0	0	0	0	0
0	0	0	1	1
0	0	1	0	2
0	0	1	1	3
0	1	0	0	4
0	1	0	1	5
0	1	1	0	6
0	1	1	1	7
1	0	0	0	8
1	0	0	1	9

Time constant used for DTMF frequency estimation				
DTMF3	DTMF2	DTMF1	DTMF0	Time Constant
1	0	1	0	10
1	0	1	1	11
1	1	0	0	12
1	1	0	1	13
1	1	1	0	14
1	1	1	1	15

14.6.2. DTMF CONTROL 2

Addr.	Name	D7	D6	D5	D4	D3	D2	D1	D0	Default
0x31	DTMFCTRL2	RES							DTMFCLR	0x00

“RES” in the register map means reserved bit(s).

Bit Location	Bit Description	Bit Name	Bit Value	
			0	1
0	DTMF Clear previous received data.	DTMFCLR	Default	Clear

14.6.3. DTMF CONTROL 3

Addr.	Name	D7	D6	D5	D4	D3	D2	D1	D0	Default
0x32	DTMFCTRL3	RES				DTMFRVDT				0x00

“RES” in the register map means reserved bit(s).

		Column frequency			
		1209 Hz	1336 Hz	1477 Hz	1633 Hz
697 Hz	1	2	3	A	
	0x01 hex	0x02 hex	0x03 hex	0x0D hex	
770 Hz	4	5	6	B	
	0x04 hex	0x05 hex	0x06 hex	0x0E hex	
852 Hz	7	8	9	C	
	0x07 hex	0x08 hex	0x09 hex	0x0F hex	
941 Hz	*	0	#	D	
	0x0B hex	0x0A hex	0x0C hex	0x00 hex	

14.6.4. DTMF STATUS (READ ONLY)

Addr.	Name	D7	D6	D5	D4	D3	D2	D1	D0	Default
0x33	DTMFST	RES							DTMFEMT (RO)	0x01

“RES” in the register map means reserved bit(s). It is a **Read ONLY** bit

Bit Location	Bit Description	Bit Name	Bit Value	
			0	1
0	DTMF buffer is empty	DTMFEMT	Pending Data	Buffer is Empty

14.6.5. DTMF THRESHOLD

Addr.	Name	D7	D6	D5	D4	D3	D2	D1	D0	Default
0x34	DTMFTHRH	DTMFTHR[15:8]								0xE4
0x35	DTMFTHRL	DTMFTHR[7:0]								0xE5

This is the signal level threshold which must be present to detect a DTMF tone.

14.6.6. DTMF PRESENT DETECT TIME

Addr.	Name	D7	D6	D5	D4	D3	D2	D1	D0	Default
0x36	DTMFPDT	DTMFPDT[7:0]								0x00

DTMF PRESENT DETECT TIME			
The time for which a tone must be present to be qualified as a valid DTMF tone			
	Minimum	Maximum	Increment
Range	0 ms	127 ms	0.5 ms

14.6.7. DTMF ABSENT DETECT TIME

Addr.	Name	D7	D6	D5	D4	D3	D2	D1	D0	Default
0x37	DTMFADT	DTMFADT[7:0]								0x00

DTMF ABSENT DETECT TIME			
The time for which a tone must be absent before a signal is considered a new DTMF tone			
	Minimum	Maximum	Increment
Range	0 ms	127 ms	0.5 ms

14.6.8. DTMF ACCEPT TIME

Addr.	Name	D7	D6	D5	D4	D3	D2	D1	D0	Default
0x38	DTMFACT	DTMFACT[7:0]								0x00

DTMF ACCEPT TIME			
The time for which a tone must be stable to be qualified as a correct tone			
	Minimum	Maximum	Increment
Range	0 ms	127 ms	0.5 ms

This guard time improves detection performance by rejecting detected signals with insufficient duration and by masking momentary detection dropout.

14.6.9. DTMF RECEIVE DATA STATUS

Addr.	Name	D7	D6	D5	D4	D3	D2	D1	D0	Default
0x3A	DTMFRDT	DTMFRDY	DTMFST	<i>RES</i>		DTMFRDT[3:0]				0x00

“RES” in the register map means reserved bit(s).

DTMF Detector received data, DTMFRDT[3:0]. This data is valid when DTMF Ready, DTMFRDY[7], is active.

Bit Location	Bit Description	Bit Name	Bit Value	
			0	1
6	DTMF State (indicates whether a valid DTMF tone is currently being detected and DTMF Present Time DTMFPDT[7:0], is qualified.)	DTMFST	Data Not Valid	Data Valid
7	DTMF Ready (indicates that a valid DTMF tone has been present for required DTMF Hold Time (ACCT))	DTMFRDY	Data Not Ready	Data Ready

	Row Frequency	Column frequency			
		1209 Hz	1336 Hz	1477 Hz	1633 Hz
697 Hz	1	2	3	A	
	0x01 hex	0x02 hex	0x03 hex	0x0D hex	
770 Hz	4	5	6	B	
	0x04 hex	0x05 hex	0x06 hex	0x0E hex	
852 Hz	7	8	9	C	
	0x07 hex	0x08 hex	0x09 hex	0x0F hex	
941 Hz	*	0	#	D	
	0x0B hex	0x0A hex	0x0C hex	0x00 hex	

14.6.10. DTMF ROW FREQUENCY

Addr.	Name	D7	D6	D5	D4	D3	D2	D1	D0	Default
0x3B	DTMFRFH	DTMFRF[15:8]								0x00
0x3C	DTMFRFL	DTMFRF[7:0]								0x00

These two bytes are for debug mode, and display the DTMF Row frequency directly.

- DTMFRF[15:3] is the integer part of the DTMF Row frequency,
- DTMFRF[2:0] is the decimal fraction part of the DTMF Row frequency (13.3 format).

14.6.11. 14/15 DTMF COLUMN FREQUENCY

Addr.	Name	D7	D6	D5	D4	D3	D2	D1	D0	Default
0x3D	DTMFCFH	DTMFCF[15:8]								0x00
0x3E	DTMFCFL	DTMFCF[7:0]								0x00

These two bytes are for debug mode, and display the DTMF Column frequency directly.

- DTMFCF[15:3] is the integer part of the DTMF Column frequency,
- DTMFCF[2:0] is the decimal fraction part of the DTMF Column frequency (13.3 format).

14.7. LINE REGISTERS
14.7.1. AC PATH GAIN

Addr.	Name	D7	D6	D5	D4	D3	D2	D1	D0	Default
0x40	APG	RAMP	PREN	VOHZ	RES	ARX[1:0]		ATX[1:0]		0x00

Analog Receive Gain		
ARX1	ARX0	Gain (dB)
0	0	0
0	1	- 3.5
1	0	+ 3.5
1	1	Mute

Analog Transmit Gain		
ATX1	ATX0	Gain (dB)
0	0	0
0	1	- 3.5
1	0	+ 3.5
1	1	Mute

Bit Location	Bit Description	Bit Name	Bit Value	
			0	1
5	Wink function	VOHZ	Return to nominal V_{RING}	Ramp towards 0 V_{RING}
6	Soft Polarity Reversal	PREN	Disable	Enable
7	Soft Polarity Reversal ramp	RAMP	1.484 V/125 μ s	2.968 V/125 μ s

14.7.2. HYBRID BALANCE

Addr.	Name	D7	D6	D5	D4	D3	D2	D1	D0	Default
0x41	HB	DACG	ADCG	RES			AHYB[2:0]			0x1B

Bit Location	Bit Description	Bit Name	Bit Value	
			0	1
6	Analog ADC Path Gain	ADCG	-6 dB	0 dB
7	Analog DAC Path Gain	DACG	0 dB	6 dB

Audio Hybrid Balance Adjustment			
AHYB2	AHYB1	AHYB0	Trans hybrid Gain
0	0	0	+4.08
0	0	1	+2.50
0	1	0	+1.16
0	1	1	0
1	0	0	- 1.02
1	0	1	- 1.94
1	1	0	- 2.77
1	1	1	Disable

14.7.3. COMMON RINGING BIAS ADJUST DURING RINGING

Addr.	Name	D7	D6	D5	D4	D3	D2	D1	D0	Default	
0x42	VCMR	RES		VCMR[5:0]							0x00

“RES” in the register map means reserved bit(s).

The above register sets Common Ringing Bias Adjustment voltage during Ringing. To convert decimal value to hex value please refer to the beginning of this section (Register Description).

	COMMON RINGING BIAS ADJUST VOLTAGE DURING RINGING		
	Minimum	Maximum	Increment
Range	0 V	−93.5 V	1.484 V

14.7.4. LINE AUTOMATIC MANUAL CONTROL

Addr.	Name	D7	D6	D5	D4	D3	D2	D1	D0	Default	
0x43	LAMC	RES					PAA	RGA	LCDA		0x07

“RES” in the register map means reserved bit(s).

Bit Location	Bit Description	Bit Name	Bit Value	
			0	1
0	Loop Closure Detect Automatic	LCDA	Manual Mode	Automatic Control
1	RING Automatic	RGA	Manual Mode	Automatic RING Control
2	Power Alarm Automatic React (Enters Open state automatically upon power alarm regardless of current state)	PAA	Manual Mode	Automatic Control

In RING Automatic, LAMC:RGA[1] address (0x43), when entering Ringing state the RING Oscillator is automatically enabled. Both OSN:O2E[1] address (0xC0) and RMPC:R1EN[5] address (0xC1) are set automatically. Enter Active state from ringing state automatically upon RING Trip Detect. The RING Oscillators are automatically disabled. Forward or Reverse states determined primarily by OHV:SB[6] address (0x4C) Upon entering Loop Closure Detect Automatic LAMC:LCDA[0] address (0x43) the device will enter the Active state from Idle, TIP Open, RING Open and ON-HOOK Transmission states automatically upon Loop Closure Detect. Forward or Reverse states determined primarily by OHV:SB[6] address (0x4C).

14.7.5. LINEFEED STATUS

Addr.	Name	D7	D6	D5	D4	D3	D2	D1	D0	Default
0x44	LS	SLS[3:0]				LS[3:0]				0x00

LineFeed Status				
LS3	LS2	LS1	LS0	State
0	0	0	0	Open
0	0	0	1	Forward Active
0	0	1	0	Forward ON-HOOK Transmission
0	0	1	1	TIP Open
0	1	0	0	Ringing
0	1	0	1	Reverse Active
0	1	1	0	Reverse ON-HOOK Transmission
0	1	1	1	RING Open
1	0	0	1	Forward Idle
1	1	0	1	Reverse Idle
1	1	1	0	Calibration Mode

LS:LS[3:0] is the Linefeed Status Register bits which reflects the programmed linefeed state, not necessarily the actual linefeed state. See LS:SLS[3:0] definition. When automatic transitions occur LS:LS[3:0] will also update accordingly.

SLS[3:0] is the Shadow Linefeed Status Register bits which reflects the actual real-time linefeed state. Automatic operations may cause actual linefeed state to deviate from the state defined in LS:LS[3:0]. For example when LS:LS[3:0] is programmed for 'Ringing' state, LS:SLS[3:0] will only indicate 'Ringing' during the actual RING burst. During the RING cadence LS:SLS[3:0] will indicate 'ON-HOOK Transmission'. This register has the same setting as the Linefeed Status Register bits.

14.7.6. LOOP CURRENT LIMIT

Addr.	Name	D7	D6	D5	D4	D3	D2	D1	D0	Default
0x45	LCL	LGCRT	LGCRR	LGCM[1:0]		RES	ILM[2:0]			0x00

"RES" in the register map means reserved bit(s). To convert Current Limit decimal value to hex value please refer to the beginning of this section (Register Description).

	CURRENT LIMIT [ILM[2:0]]		
	Minimum	Maximum	Increment
Range	20 mA [0x00]	41 mA [0x07]	3 mA

LGCM1	LGCM0	Common Mode Correction
0	0	Open (none)
0	1	Small (one)
1	0	Medium (two)
1	1	Large (three)

Bit Location	Bit Description	Bit Name	Bit Value	
			0	1
6	Series Resistor with CRn	LGCRR	OFF	ON
7	Series Resistor with CTn	LGCRT	OFF	ON

14.7.7. RING TRIP DETECT STATUS/ LOOP CLOSURE STATUS (READ ONLY)

Addr.	Name	D7	D6	D5	D4	D3	D2	D1	D0	Default
0x46	RTLCL	RTM	LCM	VBLC	RTDUD (RO)	RTDUA (RO)	LCDU (RO)	RTD (RO)	LCD (RO)	0x00

“RES” in the register map means reserved bit(s).

RING Trip Detect Unfiltered Indicator (RTDUD) bit reflects the real-time output of RING trip detects circuit before debounce. Loop Closure Detect Unfiltered Indicator (LCDU) bit reflects the real-time output of Loop Closure Detect circuit before debounce. **Bits of register RTLCL[7:5] are READ/WRITE but the bits RTLCL[4:0] are READ ONLY**

Bit Location	Bit Description	Bit Name	Bit Value	
			0	1
0	Loop Closure Detect (filtered output)	LCD	LCD has not occurred	LCD has occurred
1	RING Trip Detect (filtered output)	RTD	RTD has not occurred	RTD has occurred
2	Loop Closure Detect Unfiltered	LCDU	Threshold not exceeded	Threshold exceeded
3	RING Trip Detect Unfiltered AC	RTDUA	Threshold not exceeded	Threshold exceeded
4	RING Trip Detect Unfiltered DC	RTDUD	Threshold not exceeded	Threshold exceeded
5	Voltage-Based Loop Closure	VBLC	LC determined by loop current	LC determined by Tip to RING voltage
6	Loop Closure Mask Counter	LCM	Disabled	Enabled
7	Ring Trip Mask Control	RTM	Disabled	Enabled

14.7.8. LOOP CLOSURE DEBOUNCE

Addr.	Name	D7	D6	D5	D4	D3	D2	D1	D0	Default
0x47	LCDB	LCDI[7:0]								0x00

Loop Closure Detect Debounce Interval LCDI[7:0] is an 8-bit register which sets time interval (decimal value) in digital format. To convert decimal value to hex value please refer to the beginning of this section (Register Description).

	LOOP CLOSURE DEBOUNCE INTERVAL		
	Minimum	Maximum	Increment
Range	0 msec	159 msec	1.25 msec

14.7.9. RING TRIP DEBOUNCE INTERVAL

Addr.	Name	D7	D6	D5	D4	D3	D2	D1	D0	Default
0x48	RTDBA	ARTDI[7:0]								0x00

RING Trip Detect Debounce Interval ARTDI[6:0] is an 8-bit register which sets time interval (decimal value) in digital format. To convert decimal value to hex value please refer to the beginning of this section (Register Description).

	RING TRIP DEBOUNCE		
	Minimum	Maximum	Increment
Range	0 msec	159 msec	1.25 msec

14.7.10. PWM PERIOD

Addr.	Name	D7	D6	D5	D4	D3	D2	D1	D0	Default
0x49	PWMT	PT[7:0]								0xFF

This register sets PWM period for the DC/DC converter. Use the following equation to calculate the period.

$$\text{PWM Period} = (\text{PT}[7:0] + 1) \times \text{PLL Period}$$

The PWM period should be set to a value greater than the DC/DC Converter Minimum OFF Time

$$\text{PWMT:PT}[7:0] > \text{DDCC:DCCOFF}[4:0]$$

The PLL Period (expressed in nsec) which is selected based on the setting of PON:CDCC[7] address (0x22) and whether the BCLK is binary or decimal.

14.7.11. DC/DC CONTROLLER CONTROL

Addr.	Name	D7	D6	D5	D4	D3	D2	D1	D0	Default
0x4A	DDCC	DCOFF[7:0]								0x76

This register sets DC/DC Converter Minimum OFF Time. Use the following equation to calculate the period. DCOFF[7:0] should be programmed to values ≥ 04 hex

$$TOFF = DCOFF[7:0] \times PLL \text{ Period}$$

The PLL Period (expressed in nsec) which is selected based on the setting of PON:CDCC[7] address (0x22) and whether the BCLK is binary or decimal.

14.7.12. ON-HOOK VOLTAGE

Addr.	Name	D7	D6	D5	D4	D3	D2	D1	D0	Default
0x4C	OHV	<i>RES</i>	SB	VOH[5:0]						0x20

“RES” in the register map means reserved bit(s).

	ON-HOOK VOLTAGE ($V_{TIP} - V_{RING}$) [VOH]			
	Minimum	Maximum	Increment	Default
Range	0 V	- 93.5 V	1.484 V	- 47.488 V

Bit Location	Bit Description	Bit Name	Bit Value	
			0	1
6	Determines polarity of Idle, Active, and On-hook transition states after automatic transitions	SB	Forward	Reverse

14.7.13. GROUND MARGIN VOLTAGE

Addr.	Name	D7	D6	D5	D4	D3	D2	D1	D0	Default
0x4D	GMV	UBR	RES	VGM[5:0]						0x02

“RES” in the register map means reserved bit(s).

	GROUND MARGIN VOLTAGE [VGM]			
	Minimum	Maximum	Increment	Default
Range	0 V	- 93.5 V	1.484 V	-2.968 V

Bit Location	Bit Description	Bit Name	Bit Value	
			0	1
7	Unbalanced Ringing	UBR	Balanced Ringing	Unbalanced Ringing

14.7.14. HIGH BATTERY VOLTAGE

Addr.	Name	D7	D6	D5	D4	D3	D2	D1	D0	Default
0x4E	VBHV	XBATR	RES	VBATH[5:0]						0x32

“RES” in the register map means reserved bit(s).

	HIGH BATTERY VOLTAGE [VBATH]			
	Minimum	Maximum	Increment	Default
Range	0 V	- 93.5 V	1.484 V	- 74.2 V

Bit Location	Bit Description	Bit Name	Bit Value	
			0	1
7	External Battery Enable	XBATR	Disabled	Enabled

14.7.15. LOW BATTERY VOLTAGE

Addr.	Name	D7	D6	D5	D4	D3	D2	D1	D0	Default
0x4F	VBLV	RES		VBATL[5:0]						0x10

“RES” in the register map means reserved bit(s).

	LOW BATTERY VOLTAGE [VBATL]			
	Minimum	Maximum	Increment	Default
Range	0 V	- 93.5 V	1.484 V	- 23.744 V

14.7.16. LOOP CLOSURE DETECT/RING TRIP DETECT COEFFICIENT

Addr.	Name	D7	D6	D5	D4	D3	D2	D1	D0	Default
0x50	LCDC	LCDC[7:0]								0x00
0x51	RTDFCLD	ARTDFC[7:0]								0x00
0x52	DCHD	ARTDFC[11:8]				LCDC[11:8]				0x00

Loop Closure Detect Coefficient LCDC[11:0] is governed by the cutoff frequency f_{LP}

$$LCDC[11 : 0] = \left(1 - 2 * \pi * \left(\frac{f_{LP}}{800Hz} \right) \right) * 2^{12}$$

AC Ring Trip Detect Filter Coefficient ARTDFC[11:0] is governed by the cutoff frequency f_{LP}

$$ARTDFC[11 : 0] = \left(1 - 2 * \pi * \left(\frac{f_{LP}}{800Hz} \right) \right) * 2^{12}$$

14.7.17. LOOP CLOSURE DETECT THRESHOLD WITHOUT / WITH HYSTERESIS

Addr.	Name	D7	D6	D5	D4	D3	D2	D1	D0	Default
0x53	LCT	RES			LCT[5:0]					0x00
0x54	LCTHY	DBTR	LCHYEN	LCTOFF[5:0]					0x00	

“RES” in the register map means reserved bit(s).

Bit Location	Bit Description	Condition	Bit Name	Range	Increment	
(0x53) D0 - D5	Loop Closure Detect Threshold	If hysteresis enabled (LCTHY:LCHYEN=1) LCT[5:0] only used to determine transitions from ON-HOOK to OFF-HOOK state	Current Based (RTL:VBLC=0,)	LCT	0 to 80 mA	1.27 mA
			Voltage Based (RTL:VBLC=1,)		0 to 93.5 V	1.484 V
(0x54) D0 - D5	Loop Closure Detect Threshold with hysteresis	Only valid if hysteresis enabled (LCTHY:LCHYEN=1) LCTOFF[5:0] only used to determine transitions from OFF-HOOK to ON-HOOK state	Current Based	LCTOFF	0 to 80 mA	1.27 mA
			Voltage Based (LCDB:VBLC=1)		0 to 93.5 V	1.484 V

Bit Location	Bit Description	Bit Name	Bit Value	
			0	1
6	Loop Closure Hysteresis	LCHYEN	Disable	Enable
7	Dynamic Battery Target	DBTR	Disable	Enable

14.7.18. RING TRIP DETECT THRESHOLD

Addr.	Name	D7	D6	D5	D4	D3	D2	D1	D0	Default
0x55	RTTA	<i>RES</i>		ARTT[5:0]						0x00

RING TRIP DETECT THRESHOLD [ARTT]			
	Minimum	Maximum	Increment
Range	0 A	80 mA	1.27 mA

14.7.19. OFFSET VOLTAGE

Addr.	Name	D7	D6	D5	D4	D3	D2	D1	D0	Default
0x56	VOV	<i>RES</i>			TR	VOV[3:0]				0x00

“RES” in the register map means reserved bit(s).

The Tracking Mode is enabled by set TR bit HIGH and disabled by setting it LOW.

Offset Voltage between TIP and RING [VOV]				
	Minimum	Maximum	Increment	Default
Range	0 V	24 V	1.484 V	3.0 V

Bit Location	Bit Description	Bit Name	Bit Value	
			0	1
4	Tracking Mode	TR	$ V_{BAT} $ will not go below V_{BATL}	V_{BAT} tracks V_{RING} in constant current region

14.7.20. DC/DC TIME ON

Addr.	Name	D7	D6	D5	D4	D3	D2	D1	D0	Default
0x57	DCTON	<i>RES</i>			TONDC[5:0]					0x00

“RES” in the register map means reserved bit(s).

Minimum DCDC on time

14.7.21. DAC/ADC AUTOMUTE FUNCTION

Addr.	Name	D7	D6	D5	D4	D3	D2	D1	D0	Default
0x5E	AUTOMT	AMTEN	AMTSEL	AMTTHR						0x00

Bit Location	Bit Description	Bit Name	Bit Value	
			0	1
6	Automute Select	AMTSEL	DAC data + ADC data	DAC data only
7	Automute Enable	AMTEN	Disabled	Enabled

Automute Threshold	
Modes	AMTTHR[5:0]
Linear	0
u-Law	0
A-law	8

14.8. GROUND KEY DETECTION

14.8.1. LINEFEED CONTROL

Addr.	Name	D7	D6	D5	D4	D3	D2	D1	D0	Default
0x5F	XBTC	<i>RES</i>	ASQH	CBP	XBEN	XTBOT1	XTBOT0	XTBAT[1:0]		0x00

“RES” in the register map means reserved bit(s).

Bit Location	Bit Description	Bit Name	Bit Value	
			0	1
2	DC Bias Current OFF-Hook	XTBOT0	8 mA	4 mA
3	DC Bias Current On-Hook TR	XTBOT1	4 mA	8 mA
4	Ringer Bias Enable	XBEN	Disable	Enable
5	Capacitor Bypass	CBP	capacitors CP() and CM (C2) in circuit	Capacitors CT and CR bypassed
6	Audio Mute	ASQH	STIPAC and SRINGAC pins are not muted	STIPAC and SRINGAC pins are muted

The DC bias current flows through external BJTs in the both On-Hook Transmission and in Active Off-Hook State. Increasing this value (External Transistor Bias Levels) increases the TIP to RING peak of the differential AC current.

Current Limit adjustment		
XTBA1	XTBA0	DC Bias Current
0	0	Nominal ILIM
0	1	+1 mA
1	0	+2 mA
1	1	-1 mA

14.8.2. GROUND KEY DETECT HIGH/LOW THRESHOLD

Addr.	Name	D7	D6	D5	D4	D3	D2	D1	D0	Default
0x60	GKDH	<i>RES</i>	HGKD[7:0]						0x00	
0x61	GKDL	<i>RES</i>	LGKD[7:0]						0x00	

Range	GKD HIGH/LOW THRESHOLD		
	Minimum	Maximum	Increment
	0 A	80 mA	1.27mA

14.8.3. GROUND KEY DETECT DEBOUNCE TIME

Addr.	Name	D7	D6	D5	D4	D3	D2	D1	D0	Default
0x62	GKDDT	DTGKD[7:0]								0x00

	GKD DEBOUNCE TIME		
	Minimum	Maximum	Increment
Range	0 msec	320 msec	1.25 msec

14.8.4. GROUND KEY DETECT FILTER COEFFICIENT LOW/ HIGH

Addr.	Name	D7	D6	D5	D4	D3	D2	D1	D0	Default
0x63	GKDFCL	FCGKD[7:0]								0x00
0x64	GKDFCH	GKDEN	RES			FCGKD[11:8]			0x00	

Ground Key Detection Filter Coefficient governs the Ground Key Detect LPF cutoff frequency f_{LP}

$$FCGKD[11 : 0] = \left(1 - 2 * \pi * \left(\frac{f_{LP}}{800\text{Hz}} \right) \right) * 2^{12}$$

Bit Location	Bit Description	Bit Name	Bit Value	
			0	1
7	Enable Ground Key detection	GKDEN	Disable	Enable

14.8.5. DC RING TRIP DEBOUNCE FILTER COEFFICIENT LOW

Addr.	Name	D7	D6	D5	D4	D3	D2	D1	D0	Default
0x65	RTDCDL	DRTDFC[7:0]								0x00
0x66	DCHD	RES			DRTDFC[11:8]			0x00		

DC Ring Trip Coefficient is governed by the cutoff frequency f_{LP}

$$DRTFC[11:0] = \left[\frac{1 - (2 * \pi * f_{LP})}{800} \right] * 2^{12}$$

14.8.6. DC RING TRIP CURRENT THRESHOLD

Addr.	Name	D7	D6	D5	D4	D3	D2	D1	D0	Default
0x67	RTTD	<i>RES</i>	XRTR	DRTT[5:0]						0x00

DC Ring Trip current Threshold in Internal Ringing Mode

	RING TRIP DETECT THRESHOLD [DRTT]		
	Minimum	Maximum	Increment
Range	0 A	80 mA	1.27 mA

14.8.7. DC RING TRIP DEBOUNCE TIME

Addr.	Name	D7	D6	D5	D4	D3	D2	D1	D0	Default
0x68	RTDBD	DRTD[7:0]								0x00

	DC RING TRIP DEBOUNCE TIME		
	Minimum	Maximum	Increment
Range	0 msec	159 msec	1.25 msec

14.8.8. EXTERNAL BATTERY SWITCH OUTPUT CONFIGURATION 1

Addr.	Name	D7	D6	D5	D4	D3	D2	D1	D0	Default
0x6A	XBSDCN	DCNXB[7:0]								0x00
0x6B	XBSDCP	DCPXB[7:0]								0x00

External battery switch DCN pin and DCP output configuration for different line states

Linefeed State	XBSDCN Register XBSDCP Register								DCN output DCP output
	D7	D6	D5	D4	D3	D2	D1	D0	
Open	x	x	x	x	x	x	x	0	LOW
Open	x	x	x	x	x	x	x	1	HIGH
Forward/Reverse Active	x	x	x	x	x	x	0	x	LOW
Forward/Reverse Active	x	x	x	x	x	x	1	x	HIGH
Forward/Reverse ON-HOOK Transmission	x	x	x	x	x	0	x	x	LOW
Forward/Reverse ON-HOOK Transmission	x	x	x	x	x	1	x	x	HIGH
TIP/RING Open	x	x	x	x	0	x	x	x	LOW
TIP/RING Open	x	x	x	x	1	x	x	x	HIGH
Ringing	x	x	x	0	x	x	x	x	LOW
Ringing	x	x	x	1	x	x	x	x	HIGH
Forward/Reverse Idle	x	x	0	x	x	x	x	x	LOW
Forward/Reverse Idle	x	x	1	x	x	x	x	x	HIGH
Calibration Mode	x	0	x	x	x	x	x	x	LOW
Calibration Mode	x	1	x	x	x	x	x	x	HIGH

14.8.9. DC/DC HEAVY CURRENT CONVERTER

Addr.	Name	D7	D6	D5	D4	D3	D2	D1	D0	Default
0x6E	LOAD	RES							LOAD	0x00

Bit Location	Bit Description	Bit Name	Bit Value	
			0	1
0	DC/DC Heavy Current Load	LOAD	Light load	Heavy Current Load such as Ringing for DC/DC converter

14.8.10. DC/DC TARGET VOLTAGE (READ ONLY)

Addr.	Name	D7	D6	D5	D4	D3	D2	D1	D0	Default
0x77	DCTR	VTR[7:0] (RO)								0XC8

In Inductor mode the Target Voltage for DC/DC Converter is a **READ ONLY** register.

	DC/DC TARGET VOLTAGE [VTR]			
	Minimum	Maximum	Increment	Default
Range	0 V	- 93.5 V	1.484 V	3.0 V

14.9. MONITORING REGISTERS

14.9.1. MONITOR CURRENT FOR RING TRIP AND LOOP CLOSURE

Addr (Hex)	Name	Bit7	Bit6	Bit5	Bit4	Bit3	Bit2	Bit1	Bit0	Default (Hex)	R/W
78	RTMNT	MNTRT[7:0]								00	RO
79	LCMNT	MNTLC[7:0]								00	RO

RING TRIP CURRENT MONITOR LOOP CLOSURE CURRENT MONITOR			
	Minimum	Maximum	Increment
Range	0 A	80 mA	0.317 mA

14.9.2. MONITOR CURRENT FOR RING TRIP AND LOOP CLOSURE

Addr (Hex)	Name	Bit7	Bit6	Bit5	Bit4	Bit3	Bit2	Bit1	Bit0	Default (Hex)	R/W
7A	MNT5	MNTQ1[7:0]									RO
7B	MNT7	MNTQ2[7:0]									RO
7C	MNT9	MNTQ3[7:0]									RO
7D	MNT11	MNTQ4[7:0]									RO
7E	MNT13	MNTQ5[7:0]									RO
7F	MNT15	MNTQ6[7:0]									RO

TRANSISTOR POWER DESSIPATION TIP, RING, and LOOP CURRENT SENSE					
DESCRIPTION	CONDITION	Range	Minimum	Maximum	Stepsize
Dependent on the maximum power dissipation rating of the external transistors	QT1 and QR1	PATHQ2	0 W	7.70 W	30.4 mW
	QT2 and QR2	PATHQ1	0 W	0.97 W	3.80 mW
	QT3 and QR3	PATHQ3	0 W	7.70 W	30.4 mW

14.10. LINE CONTROL REGISTERS

14.10.1. VOLTAGE REGISTERS

14.10.1.1. BATTERY VOLTAGE SENSE (READ ONLY)

Addr.	Name	D7	D6	D5	D4	D3	D2	D1	D0	Default
0x80	BATV	VB[7:0] (RO)								0x02

Battery Voltage VB[7:0] is a **READ ONLY** register.

	BATTERY VOLTAGE SENSE [VB]		
	Minimum	Maximum	Increment
Range	0 V	- 95.88 V	0.376 V

14.10.1.2. TIP/RING VOLTAGE SENSE (READ ONLY)

Addr.	Name	D7	D6	D5	D4	D3	D2	D1	D0	Default
0x81	VTIP	VTIP[11:4] (RO)								0x00
	VTRIP (XP)	VTIP[3:0] (RO)				RES				
0x82	VRING	VRING[11:4] (RO)								0x00
	VRING (XP)	VRING[3:0] (RO)				RES				

“XP” stands for extra precision register. TIP and RING voltage is a **READ ONLY** register. The range value depends on calibration. The values provided for range is without any calibration. Please refer to the SPI Peripheral Interface section for details.

	TIP AND RING VOLTAGE SENSE [VTIP, VRING]			Precision Bits
	Minimum	Maximum	Increment	
Range	0 V	-95.88 V	374 mV	8
	0 V	-95.88 V	23.4 mV	12

14.10.1.3. TIP/RING TRANSISTOR 3 EMITTER VOLTAGE SENSE (READ ONLY)

Addr.	Name	D7	D6	D5	D4	D3	D2	D1	D0	Default
0x83	QT3V	QT3V[7:0] (VTVE) (VQT2) (RO)								0x03
0x84	QR3V	QR3V[7:0] (VRVE) (VQR2) (RO)								0x02

Transistors QT3 / QR3 Emitter Voltage (QT3V, QR3V) is a **READ ONLY** register. The range value depends on calibration. The values provided for range is without any calibration.

	TRANSISTORS QT3 / QR3 EMITTER VOLTAGE		
	Minimum	Maximum	Increment
Range	0 V	- 95.88 V	0.376V

14.11. TRANSISTOR CURRENT REGISTERS (TIP/RING TRANSISTOR 1/2/3 CURRENT SENSE)

Addr.	Name	D7	D6	D5	D4	D3	D2	D1	D0	Default	
0x85	QT3I	QT3I[11:4]									0x05
	QT3I (XP)	QT3I[3:0]			RES						
0x86	QR3I	QR3I[11:4]									0x03
	QR3I (XP)	QR3I[3:0]			RES						
0x87	QT1I	QT1I[11:4]									0x03
	QT1I (XP)	QT1I[3:0]			RES						
0x88	QT2I	QT2I[11:4]									0x03
	QT2I (XP)	QT2I[3:0]			RES						
0x89	QR1I	QR1I[11:4]									0x03
	QR1I (XP)	QR1I[3:0]			RES						
0x8A	QR2I	QR2I[11:4]									0x03
	QR2I (XP)	QR2I[3:0]			RES						

“XP” stands for extra precision register. TIP/RING Transistor 1/2/3 Current register is a **READ ONLY**. The range value depends on calibration. The values provided for Range is without any calibration. Please refer to the SPI Peripheral Interface section for details.

	REAL TIME CURRENT			Precision Bits
	Range			
	Minimum	Maximum	Increment	
QT3I	0 A	78.54 mA	306 μ A	8
	0 A	78.54 mA	19.18 μ A	12
QR3I	0 A	78.54 mA	306 μ A	8
	0 A	78.54 mA	19.18 μ A	12
QT1I	0 A	78.54 mA	306 μ A	8
	0 A	78.54 mA	19.18 μ A	12
QT2I	0 A	9.95 mA	38.8 μ A	8
	0 A	9.95 mA	2.43 μ A	12
QR1I	0 A	78.54 mA	306 μ A	8
	0 A	78.54 mA	19.18 μ A	12
QR2I	0 A	9.95 mA	38.8 μ A	8
	0 A	9.95 mA	2.43 μ A	12

14.12. LOOP SUPERVISION

14.12.1. LONGITUDINAL CURRENT

Addr.	Name	D7	D6	D5	D4	D3	D2	D1	D0	Default
0x8C	LGI	ILG[11:4]								0x00
	LGI (XP)	ILG[3:0]				RES				

“XP” stands for extra precision register. The range value depends on calibration. The values provided for Range is without any calibration. Please refer to the SPI Peripheral Interface section for details.

$$ILG = \frac{(IQT1 - IQT3 - IQR3 + IQR1)}{2}$$

	LONGITUDINAL CURRENT			Precision Bits
	Minimum	Maximum	Increment	
Range	0 mA	77.62 mA	303 uA	8
	0 mA	77.62 mA	18.95 uA	12

14.12.2. LOOP VOLTAGE SENSE (READ ONLY)

Addr.	Name	D7	D6	D5	D4	D3	D2	D1	D0	Default
0x8D	LPV	VLP[11:4] (RO)								00
	LPV (XP)	VLP[3:0] (RO)				RES				

“XP” stands for extra precision register. Loop Voltage is a **READ ONLY** register. The range value depends on calibration. The values provided for Range is without any calibration. This is a 12-bit register. Please refer to the SPI Peripheral Interface section for details.

	LOOP VOLTAGE (V _{TIP} - V _{RING})			Precision Bits
	Minimum	Maximum	Increment	
Range	0 V	- 95.88 V	374 mV	8
	0 V	- 95.88 V	23.41mV	12

14.12.3. TIP, RING, AND LOOP CURRENT (READ ONLY)

Addr.	Name	D7	D6	D5	D4	D3	D2	D1	D0	Default
0x8E	TIPI	ITLP[11:4] (RO)								NA
	TIPI (XP)	ITLP[3:0] (RO)				RES				
0x8F	RINGI	IRLP[11:4] (RO)								NA
	RINGI (XP)	IRLP[3:0] (RO)				RES				
0x90	LPI	ILP[11:4] (RO)								NA
	LPI (XP)	ILP[3:0] (RO)				RES				

“XP” stands for extra precision register. The above registers are **READ ONLY**. The range value depends on calibration. The values provided for Range is without any calibration. Please refer to the SPI Peripheral Interface section for details.

	TIP, RING, and LOOP CURRENT			Precision Bits
	Minimum	Maximum	Increment	
Range	0 mA	77.62 mA	303 uA	8
	0 mA	77.62 mA	18.95 uA	12

14.12.4. POLARITY

Addr.	Name	D7	D6	D5	D4	D3	D2	D1	D0	Default
0x91	POL	RES	P2PEN	ILGP	ILPP	IRLP	ITLP	VLP		NA

Loop voltage, TIP Current, RING Current, Loop Current, and Longitudinal Current all have Sign Bit associated with it. The Polarity register contains all the Sign or Polarity bits. For these registers mentioned the range can also extend in the negative direction by setting the Sign or Polarity bit.

Bit Location	Bit Description	Bit Name	Bit Value	
			0	1
0	Loop Voltage	VLP	Positive	Negative
1	TIP Current	ITLP	Positive	Negative
2	RING Current	IRLP	Positive	Negative
3	Loop Current	ILPP	Positive	Negative
4	Longitudinal Current	ILGP	Positive	Negative
5	Loop current PK-2-PK clear	P2PEN	Clear value	Continuously updates new peak values

When P2PEN[5] is set from 0 to 1 the peak detector circuit register value is cleared. If P2PEN[5] is set to HIGH and it remain at HIGH than the peak detector circuit register value is continuously updated with new peak values.

14.12.5. COMMON MODE VOLTAGE

Addr.	Name	D7	D6	D5	D4	D3	D2	D1	D0	Default
0x92	SCM	SCM[11:4]								NA
	SCM (XP)	SCM[3:0]				RES				

“XP” stands for extra precision register. The Common Mode Voltage is calculated using the equation below. Please refer to the SPI Peripheral Interface section for details.

$$\frac{(V_{TIP} + V_{RING})}{2}$$

14.12.6. TIP EMITTER VOLTAGE FOR TRANSISTORS QT1 SENSE (READ ONLY)

Addr.	Name	D7	D6	D5	D4	D3	D2	D1	D0	Default
0x93	VEQT1	VEQT1[7:0] (RO)								NA

This is the emitter sense of the transistor QT1 which is used for the power alarm computation. This register is a **READ ONLY** register. The range value depends on calibration. The values provided for range is without any calibration.

	TIP - TRANSISTOR QT1 EMITTER VOLTAGE SENSE		
	Minimum	Maximum	Increment
Range	0 V	- 95.88 V	0.376 V

14.12.7. TIP VOLTAGE FOR TRANSISTOR QT1 SENSE (READ ONLY)

Addr.	Name	D7	D6	D5	D4	D3	D2	D1	D0	Default
0x94	VQT1	VQT1[7:0] (RO)								NA

The value in this register is derived from TIP voltage and TIP emitter voltage of the transistor. This is the emitter sense of the transistor QT1 which is used for the power alarm computation. This register is a **READ ONLY** register. The range value depends on calibration. The values provided for range is without any calibration.

	TIP - TRANSISTOR QT1 VOLTAGE SENSE		
	Minimum	Maximum	Increment
Range	0 V	- 95.88 V	0.376 V

14.12.8. RING EMITTER VOLTAGE FOR TRANSISTOR QT1 SENSE (READ ONLY)

Addr.	Name	D7	D6	D5	D4	D3	D2	D1	D0	Default
0x95	VEQR1	VEQR1[7:0] (RO)								NA

This is the emitter sense of the transistor QR1 which is used for the power alarm computation. This register is a **READ ONLY** register. The range value depends on calibration. The values provided for range is without any calibration.

	RING - TRANSISTOR QR1 EMITTER VOLTAGE SENSE		
	Minimum	Maximum	Increment
Range	0 V	- 95.88 V	0.376 V

14.12.9. RING VOLTAGE FOR TRANSISTOR QT1 SENSE (READ ONLY)

Addr.	Name	D7	D6	D5	D4	D3	D2	D1	D0	Default
0x96	VQR1	VQR1[7:0] (RO)								NA

The value in this register is derived from RING voltage and RING emitter voltage of the transistor. This is the emitter sense of the transistor QR1 which is used for the power alarm computation. This register is a **READ ONLY** register. The range value depends on calibration. The values provided for range is without any calibration.

	RING - TRANSISTOR QR1 VOLTAGE SENSE		
	Minimum	Maximum	Increment
Range	0 V	- 95.88 V	0.376 V

14.12.10. TEMPERATURE SENSE (READ ONLY)

Addr.	Name	D7	D6	D5	D4	D3	D2	D1	D0	Default
0x99	TEMP	TS[7:0] (RO)								NA

Die Temperature Sense TS[7:0] is a **READ ONLY** register. The actual temperature T is given by:

$$T = TS[7:0] - 67 \quad @ 1^{\circ}\text{C Increment}$$

14.12.11. BAND GAP VOLTAGE

Addr.	Name	D7	D6	D5	D4	D3	D2	D1	D0	Default
0x9A	VBGAP	VBG[7:0]								0x00

Bandgap Voltage Trim VBG[7:0] is a trim parameters which can be used during the calibration sequence.

14.12.12. PEAK TO PEAK LOOP VOLTAGE (READ ONLY)

Addr.	Name	D7	D6	D5	D4	D3	D2	D1	D0	Default
0x9B	VLPP2P	LPVP2P[11:4] (RO)								0x00
	VLPP2P (XP)	LPVP2P[3:0] (RO)				RES				

“XP” stands for extra precision register. This read only register captures the peak-to-peak loop voltage. The peak detector circuit clears this register value when POL:P2PEN[5] address (0X91) is set from 0 to 1 and continuously updates new peak values when P2PEN[5] is HIGH. The final peak value is held in VLPP2P:LPVP2P address (0X91) when P2PEN[5] is cleared to LOW until P2PEN[5] is set again. The peak-to-peak loop voltage is measured as (max positive peak + max negative peak) / 2.

	PEAK TO PEAK LOOP VOLTAGE			Precision Bits
	Minimum	Maximum	Increment	
Range	0 V	- 95.88 V	374 mV	8
	0 V	- 95.88 V	23.41mV	12

14.12.13. PEAK TO PEAK LOOP CURRENT (READ ONLY)

Addr.	Name	D7	D6	D5	D4	D3	D2	D1	D0	Default
0x9C	ILPP2P	LPIP2P[11:4] (RO)								NA
	ILPP2P (XP)	LPIP2P[3:0] (RO)				RES				

“XP” stands for extra precision register. This read only register captures the peak-to-peak loop current. The peak detector circuit clears this register value when POL:P2PEN[5] address (0X91) is set from 0 to 1 and continuously updates new peak values when P2PEN[5] is HIGH. The final peak value is held in ILPP2P:LPIP2P address (0X91) when P2PEN[5] is cleared to LOW until P2PEN[5] is set again. The peak-to-peak loop current is measured as (max positive peak + max negative peak) / 2.

	PEAK TO PEAK LOOP CURRENT			Precision Bits
	Minimum	Maximum	Increment	
Range	0 mA	-77.62 mA	303 uA	8
	0 mA	-77.62 mA	18.95 uA	12

14.13. POWER ALARM LPF POLE REGISTERS

14.13.1. POWER ALARM COUNTER

Addr.	Name	D7	D6	D5	D4	D3	D2	D1	D0	Default
0x9F	PALCNT	PALCNT[7:0]								0x00

The Power Alarm Counter indicates the number of rising edges of the LOWVDC or HIGHIDC flags. The value of this register clips at 255. This counter is reset after every read from this address.

- a) DCDC output voltage (VBAT) 10% above full scale or
- b) DCDC supply voltage (VDDC) too low or
- c) DCDC supply current (I_{VDDC}) too high;

14.13.2. POWER ALARM LOW PASS FILTER POLE FOR TRANSISTORS 1/2/3

Addr.	Name	D7	D6	D5	D4	D3	D2	D1	D0	Default
0xA0	PALPQ2	Q2C[7:0]								0x00
0xA1	PALPQ1	Q1C[7:0]								0x00
0xA2	PALPQ3	Q3C[7:0]								0x00
0xA3	PALPQHn	Q1C[11:8]				Q2C[11:8]				0x00
0xA4	PALPQH2	LPFEN	Q3C12	Q1C12	Q2C12	Q3C[11:8]				0x00

The Power Alarm register are 13 bit registers. For example Q2 Power Alarm bits are located at address 0xA0, (D0 – D7, Q2C[7:0]) first 8-bits. The next 4-bits are located at address 0xA3 (D0 – D3 bits, Q2C[11:8]) and the last bit out of 13-bits is located at address 0xA4 (D4 – Q2C[12]). The other two transistor bits can be located the same way. LPFEN enables the Low Pass Filter when set to 1.

POWER ALARM LOW PASS FILTER POLE FOR TRANSISTORS 1/2/3		
Dependent on the thermal time constant of the external transistors		
QT2 and QR2	QT1 and QR1	QT3 and QR3
PALPQ2	PALPQ1	PALPQ3
$Q2C[12:0] = \left(1 - \frac{1}{800 * T_{TC}}\right) * 2^{13}$	$Q1C[12:0] = \left(1 - \frac{1}{800 * T_{TC}}\right) * 2^{13}$	$Q3C[12:0] = \left(1 - \frac{1}{800 * T_{TC}}\right) * 2^{13}$

14.13.3. POWER ALARM THRESHOLD FOR TRANSISTOR 1-3

Addr.	Name	D7	D6	D5	D4	D3	D2	D1	D0	Default
0xA5	PATHQ2	Q2TH[7:0]								0x00
0xA6	PATHQ1	Q1TH[7:0]								0x00
0xA7	PATHQ3	Q3TH[7:0]								0x00

TIP, RING, and LOOP CURRENT					
DESCRIPTION	CONDITION	Range	Minimum	Maximum	Increment
Dependent on the maximum power dissipation rating of the external transistors	QT1 and QR1	PATHQ2	0 W	7.7 W	30.4 mW
	QT2 and QR2	PATHQ1	0 W	0.97 W	3.8 mW
	QT3 and QR3	PATHQ3	0 W	7.7 W	30.4 mW

14.14. IMPEDANCE MATCHING 1/2

Addr.	Name	D7	D6	D5	D4	D3	D2	D1	D0	Default
0xA8	IM1	RES				ZR1[3:0]				0x00
0xA9	IM2	RES	ZSW	RES						0x00

“RES” in the register map means reserved bit(s).

Impedance Matching/ R1 Element				
ZR13	ZR12	ZR11	ZR10	R1 (Ohm)
0	0	0	0	600 Ω
0	0	0	1	900 Ω
0	0	1	0	600 Ω
0	0	1	1	900 Ω
0	1	0	0	270 Ω
0	1	0	1	200 Ω
0	1	1	0	200 Ω
0	1	1	1	100 Ω
1	0	0	0	370 Ω
1	0	0	1	220 Ω
1	0	1	0	320 Ω
1	0	1	1	220 Ω
1	1	x	x	Not Used

Bit Location	Bit Description	Bit Name	Bit Value	
			0	1
6	Impedance matching Feedback loop Disable	ZSW	Default, enabled	Disables impedance matching feedback loop for diagnostics testing

14.14.1. TEMPERATURE ALARM THRESHOLD

Addr	Name	D7	D6	D5	D4	D3	D2	D1	D0	Default
0xAA	THAT	TATH[7:0]								0x00

$$T_{TH} = TATH[7:0] - 67 \quad @ \text{ Increment of } 1^{\circ}\text{C}$$

14.14.2. LOOP CLOSURE MASK COUNT

Addr	Name	D7	D6	D5	D4	D3	D2	D1	D0	Default
0xAB	LCMCNT	LCMCNT[7:0]								0x00

	LOOP CLOSURE MASK COUNT		
	Minimum	Maximum	Increment
Range	0 ms	319 ms	1.25 ms

14.14.3. COARSE CALIBRATION INTERNAL RESISTOR

Addr	Name	D7	D6	D5	D4	D3	D2	D1	D0	Default
0xAC	CC	<i>RES</i>			CBGSW	CTRIM[2:0]				0x00

“RES” in the register map means reserved bit(s). Coarse Calibration CTRIM[2:0] and Internal Resistor CBGSW are a trim parameters which can be used during the calibration sequence.

14.14.4. OSCILLATOR 2 RINGING PHASE DELAY

Addr.	Name	D7	D6	D5	D4	D3	D2	D1	D0	Default
0xAD	OS2RPD	O2RPD[7:0]								0x00

When Oscillator 2 is used for Tone Generation it is recommended this register be set to 0x00. If the ringing phase delay in oscillator 2 (0xAD) is used, zero crossing function must be enabled OSN:O2ZC[5] address 0xC0.

	OSCILLATOR 2 RINGING PHASE DELAY		
	Minimum	Maximum	Increment
Range	0 ms	31.8 ms	125 us

14.15. CALIBRATION

Addr	Name	D7	D6	D5	D4	D3	D2	D1	D0	Default
0xAF	CAL1	SDAT[3:0]				VBATT[3:0]				0X77
0xB0	CAL2	TVTE1[3:0]				SDBT[3:0]				0X97
0xB1	CAL3	SCMT[3:0]				RVTE[3:0]				0X79

All values are trim parameters which can be used during the calibration sequence.

Bits	Trim
VBATT[3:0]	VBAT Trim
SDAT[3:0]	SDA Trim
SDBT[3:0]	SDB Trim
TVTE1[3:0]	TVE1 Trim
RVTE[3:0]	RVE1 Trim
SCMT[3:0]	SCM Trim

14.16. DC OFFSET REGISTERS

14.16.1. DC OFFSET (RING, TIP, AND VBAT)

Addr.	Name	D7	D6	D5	D4	D3	D2	D1	D0	Default
0xB4	IQTROS	HISENSE	BTVR	ILFDB	DACSFC	<i>RES</i>				0x00

“RES” in the register map means reserved bit(s).

All values are trim parameters which can be used during the calibration sequence.

Bit Location	Bit Description	Bit Name	Bit Value	
			0	1
4	Smoothing Filter	DACSFC	Cutoff at 1xfc	Cutoff 2xfc
5	Line driver bias	ILFDB	Fixed Bias	Bias varies with coarse calibration
6	DC/DC Range	BTVR	Normal	Low VBAT
7	Monitor DC Range	HISENSE	Normal line	Extended line

14.16.2. PWM COUNT (READ ONLY)

Addr.	Name	D7	D6	D5	D4	D3	D2	D1	D0	Default
0xB5	PWCT	PWCT[7:0] (RO)								NA

This register is a **READ ONLY**. PWM Count Register can calculate DC/DC Converter Pulse Width TON with the following equation.

$$TON = PWCT[7:0] * PLL \text{ Period}$$

The TON Range is 0 ns to (PWM Period-TOFF) see PWMT and DDCC with a stepsize of PLL period. The PLL Period (expressed in nsec) which is selected based on the setting of PON:CDCC[7] address (0x22) and whether the BCLK is binary or decimal.

14.17. TONE GENERATION REGISTERS

14.17.1. OSCILLATOR CONTROL

Addr.	Name	D7	D6	D5	D4	D3	D2	D1	D0	Default
0xC0	OSN	RES		O2ZC	O1ZC	RES		O2E	O1E	0x00

“RES” in the register map means reserved bit(s).

Bit Location	Bit Description	Bit Name	Bit Value	
			0	1
0	Oscillator 1	O1E	Disable	Enable
1	Oscillator 2	O2E	Disable	Enable
4	Oscillator n Zero-Crossing	O1ZC	Disable	Enable
5	Oscillator 2 Zero-Crossing	O2ZC	Disable	Enable

14.17.2. RING CONTROL

Addr.	Name	D7	D6	D5	D4	D3	D2	D1	D0	Default
0xC1	RMPC	TRAP	LBAC	R1EN	RES	TOR	RES			0x00

“RES” in the register map means reserved bit(s).

Bit Location	Bit Description	Bit Name	Bit Value	
			0	1
3	Tone Route	TOR	Transmit direction (towards DAC)	Receive direction (towards ADC)
5	Ringer 1	R1EN	Disable	Enable
6	Ringing Waveform	LBAC	Sinusoidal RING Waveform	Trapezoidal RING Waveform
7	Ringing Waveform Select	TRAP	Disable	Enable

14.17.3. OSCILLATOR 1 AND 2 INITIAL CONDITION LOW/HIGH

Addr.	Name	D7	D6	D5	D4	D3	D2	D1	D0	Default
0xC2	OS1ICL	O1IC[7:0]								0x00
0xC3	OS1ICH	O1IC[15:8]								0x00
0xC4	OS2ICL	O2IC[7:0]								0x00
0xC5	OS2ICH	O2IC[15:8]								0x00

Initial Condition for Oscillator m OmIC[15:0] m=1, and 2 can be determined by formula. Refer to Tone Generation see Section for the formula.

14.17.4. OSCILLATOR 1 AND 2 COEFFICIENT LOW/HIGH

Addr.	Name	D7	D6	D5	D4	D3	D2	D1	D0	Default
0xC6	OS1CL	O1C[7:0]								0x00
0xC7	OS1CH	O1C[15:8]								0x00
0xC8	OS2CL	O2C[9:2]								0x00
0xC9	OS2CH	O2C[17:10]								0x00

Coefficient for Oscillator m (OmC[15:0] m=1, and 2, refer to Tone Generation see section for the formula. OS2CL is 18-bits long word. The 16 most significant bits are on address 0xC8[9:2] and 0xC9[17:10]. The 2 least significant bits are located in register address 0xDC (D7 - D6).

14.18. OSCILLATOR 1 AND 2 ACTIVE/ INACTIVE TIME LOW/HIGH

Addr.	Name	D7	D6	D5	D4	D3	D2	D1	D0	Default
0xCA	OS1ATL	O1ON[7:0]								0x00
0xCB	OS1ATH	O1ON[15:8]								0x00
0xCC	OS2ATL	O2ON[7:0]								0x00
0xCD	OS2ATH	O2ON[15:8]								0x00
0xCE	OS1ITL	O1OFF[7:0]								0x00
0xCF	OS1ITH	O1OFF[15:8]								0x00
0xD0	OS2ITL	O2OFF[7:0]								0x00
0xD1	OS2ITH	O2OFF[15:8]								0x00

				OSCILLATOR 1/2 ACTIVE/INACTIVE TIME		
				Minimum	Maximum	Stepsize
Active/Inactive Timer Oscillator m	Tone Generation	Timer is disabled by programming zero	O1ON O2ON O1OFF O2OFF	0 s	8 s	125us
Active/Inactive Timer Oscillator 2	Ringing only	Timer is disabled by programming zero	O2ON O2OFF	0 s	8 s	125us

14.19. GENERAL TONE GENERATION

14.19.1. RING OFFSET

Addr.	Name	D7	D6	D5	D4	D3	D2	D1	D0	Default
0xDC	ROFFS	O2C[1:0]			ROS[5:0]					0x00

“RES” in the register map means reserved bit(s).

TIP to RING Offset for Ringing, Sets DC Offset component to the Ringing Waveform

	RING OFFSET [ROS]		
	Minimum	Maximum	Increment
Range	0 V	47.488 V	1.484 V

14.19.2. ADC/DAC DIGITAL GAIN

Addr.	Name	D7	D6	D5	D4	D3	D2	D1	D0	Default
0xDD	ADCL	ADC[7:0]							0x00	
0xDE	DACL	DAC[7:0]							0x00	
0xDF	DGH	DAC[11:8]			ADC[11:8]				0x44	

			DIGITAL GAIN	
			Minimum	Maximum
Digital Gain	ADC = 1024x10 ^(XdB/20) DAC = 1024x10 ^(XdB/20)	ADC DAC	-∞ dB	6 dB

ADC DAC	Gain	dB
0x000	Off	-∞
0x040	1 / 8	-24
0x100	1 / 4	-12
0x200	1 / 2	-6
0x400	1	0
0x7FF	2	6

14.19.3. PWM DC/DC FINE TUNING

Addr.	Name	D7	D6	D5	D4	D3	D2	D1	D0	Default	
0xE0	ST0L0	RES				ST0L0[3:0]				0x02	
0xE1	ST1L0	RES			ST1L0[4:0]						0x04
0xE2	ST2L0	RES			ST2L0[4:0]						0x06
0xE3	ST0L1	RES				ST0L1[3:0]				0x08	
0xE4	ST1L1	RES			ST1L1[4:0]						0x10
0xE5	ST2L1	RES			ST2L1[4:0]						0x19

“RES” in the register map means reserved bit(s).

Addr.	Name	Symbol	Description	Unit
0xE0 – 0xE5	Stepsize Region State	STx	x = 0, 1, 2	Proportional to master clock period
		Ly	L0 - Non-RINGING L1 - RINGING	

Addr.	Name	Recommendation
0xE0	ST0L0	0x02
0xE1	ST1L0	0x02
0xE2	ST2L0	0x02
0xE3	ST0L1	0x08
0xE4	ST1L1	0x08
0xE5	ST2L1	0x08

14.19.4. PWM DC/DC FINE TUNING SKIP PERIOD

Addr.	Name	D7	D6	D5	D4	D3	D2	D1	D0	Default	
0xE6	SK0L0	SK0L0[7:0]								0x1F	
0xE7	SK1L0	RES			SK1L0[5:0]						0x04
0xE8	SK2L0	RES			ST2L0[4:0]						0x02
0xE9	SK0L1	SK0L1[7:0]								0x1F	
0xEA	SK1L1	RES			SK1L1[5:0]						0x04
0xEB	SK2L1	RES			SK2L1[4:0]						0x02

“RES” in the register map means reserved bit(s).

Addr.	Name	Recommendation
0xE6	SK0L0	0x06
0xE7	SK1L0	0x06
0xE8	SK2L0	0x06
0xE9	SK0L1	0x06
0xEA	SK1L1	0x06
0xEB	SK2L1	0x06

Addr.	Name	Name	Description	Unit
0xE6 – 0xEB	Skip Region State	SKx	= 0, 1, 2	# of PWM duty cycle
		Ly	L0 - Non-RINGING L1 - RINGING	

14.19.5. PWM DC/DC FINE TUNING

Addr.	Name	D7	D6	D5	D4	D3	D2	D1	D0	Default
0xEC	WM0	RES			WM0[4:0]					0x08
0xED	WM1	RES			WM1[4:0]					0x10
0xEE	WM2	RES			WM2[4:0]					0x18
0xEF	XSTEP	PWMTTC				XS[3:0]				0x53

“RES” in the register map means reserved bit(s). “n” is the number written to the register in decimal

Addr.	Name	Symbol	Description	Unit
0xEC – 0xEE	Watermark	WMx	0, 1, 2	n x 1.484V
0xEF	Fine Adjust Region	XS		n x 1.484V
0xEF	Time constant of VLoop sensing filter for PWM	PWMTTC		

Addr.	Name	Recommendation
0xEC	WM0	0x01
0xED	WM1	0x02
0xEE	WM2	0x02
0xEF	XSTEP	0x60

14.19.6. IMPEDANCE MATCH REGISTER

14.19.6.1. IMPEDENCE MATCHING COEFFICIENT RAM

Addr.	Name	D7	D6	D5	D4	D3	D2	D1	D0	Default
0xF3	IMRAM	IMDATA								0x00

Read and Write location for the Impedance Matching Coefficient RAM. Used in conjunction with Write Sequence described in IMCTRL 0xF5.

14.19.6.2. IMPEDANCE MATCHING DELAY COUNT

Addr.	Name	D7	D6	D5	D4	D3	D2	D1	D0	Default
0xF4	IMDEL	IMHYBDC[3:0]				IMB3PDC[3:0]				0x00

Bit	Impedance Matching Delay Count
IMB3PDC[3:0]	Delay count of B3Parallel path - Default no delay
IMHYBDC[7:4]	Delay count of Hybrid2 path - Default no delay

Programmed in conjunction with Impedance Matching Coefficient RAM.

14.19.6.3. IMPEDANCE MATCHING COEFFICIENT RAM CONTROL

Addr.	Name	D7	D6	D5	D4	D3	D2	D1	D0	Default
0xF5	IMCTRL	RES			IMRW	RES	IMEN	RES	IMPM	0x10

Bit Location	Bit Description	Bit Name	Bit Value	
			0	1
0	Program Impedance Matching Coefficient RAM	IMPM	Disable	Enable
2	Complex Impedance Matching enable	IMEN	Disable	Enable
4	Read/Write Impedance Matching Coefficient RAM	IMRW	Read	Write

Bits 3, 5, 6, and 7 must be set to "0". For Complex Impedance Matching Cases the appropriate set (144 Bytes) should be loaded into the following sequence into the Coefficient RAM.

Write Step Sequence:

1. Set IMCTRL:IMRW[4] to 1
2. Set IMCTRL:IMPM[0] to 1
3. WRITE all 144 Bytes of Impedance Matching Coefficient set to Register IMRAM (Address 0xF3) in sequence
4. Set IMCTRL:IMPM[0] to 0

Read Step Sequence:

1. Set IMCTRL:IMRW[4] to 0
2. Set IMCTRL:IMPM[0] to 1
3. READ all 144 Bytes of Impedance Matching Coefficient set from Register IMRAM (Address 0xF3) in sequence
4. Set IMCTRL:IMRW[4] to 1 (to Restore Default Value)
5. Set IMCTRL:IMPM[0] to 0

Once the of Impedance Matching coefficients are loaded into the RAM, the Complex Impedance is enabled by setting IMCTRL:IMEN[2]

14.19.6.4. PCM SCALING

Addr.	Name	D7	D6	D5	D4	D3	D2	D1	D0	Default
0xF6	PCMSCAL	PCMSCAL[7:0]								0x00
0xF7	PCMSCAH	PCMSCAL[15:8]								0x20

Bit	PCM Scaling
PCMSCA[15:0]	Scaling for PCM signal. Format: 3.13

14.19.6.5. RESERVED REGISTERS

Addr.	Name	D7	D6	D5	D4	D3	D2	D1	D0	Default
0xF8		<i>RES</i>								0x00
0xF9		<i>RES</i>								0x00
0xFA		<i>RES</i>								0x00

These three register must be set to 0x00 during a write operation

14.19.6.6. FILTER BYPASS

Addr.	Name	D7	D6	D5	D4	D3	D2	D1	D0	Default
0xFB	IMEN	<i>RES</i>					ADCLPFBYP	HBLPFBYP	0x00	

Bit	PCM Scaling
HBLPFBYP[0]	Bypass the HB LPF. Default: 0(not bypass)
ADCLPFBYP[1]	Bypass the ADC LPF. Default: 0(not bypass)

15. TIMING DIAGRAM

15.1. PCM TIMING DIAGRAM FOR NON-GCI

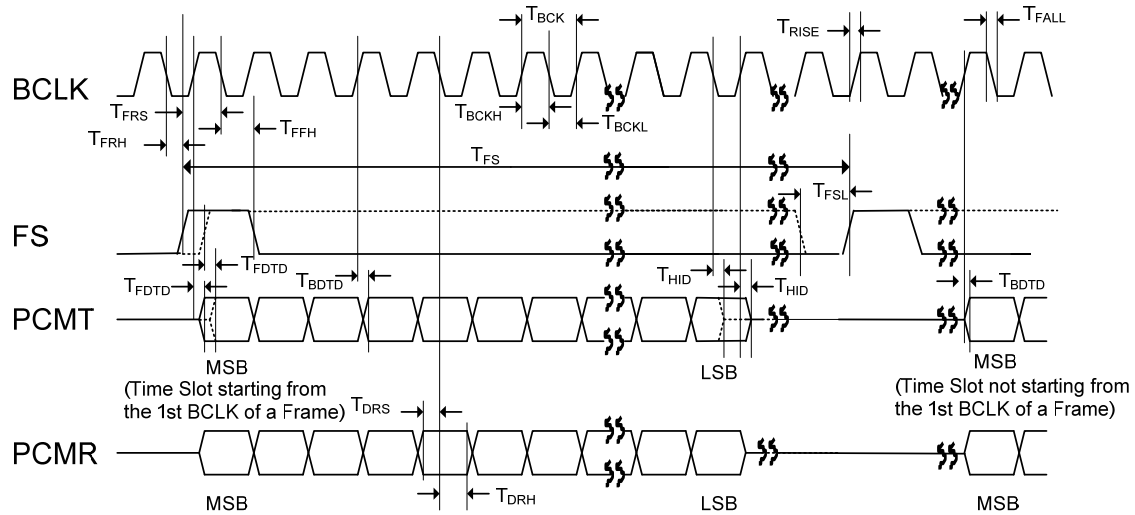

Figure 37: PCM Timing for Non-GCI

SYMBOL	DESCRIPTION	MIN	TYP	MAX	UNIT
$1/T_{FS}$	FS Frequency	---	8	---	kHz
T_{FSL}	FS Minimum LOW Width	T_{BCK}			sec
$1/T_{BCK}$	BCLK, BCLK Frequency	256	---	8192	kHz
T_{BCKH}	BCLK HIGH Pulse Width	50	---	---	ns
T_{BCKL}	BCLK LOW Pulse Width	50	---	---	ns
T_{FRH}	BCLK Falling Edge to FS Rising Edge Hold Time	20	---	---	ns
T_{FRS}	FS Rising Edge to BCLK Falling edge Setup Time	25	---	---	ns
T_{FFH}	BCLK Falling Edge to FS Falling Edge Hold Time	20	---	---	ns
T_{FDTD}	The later of BCLK Rising Edge or FS Rising Edge to valid PCMT Delay Time if MSB Starts from the 1 st BCLK of a Frame	---	---	20	ns
T_{BDTD}	BCLK Rising Edge to Valid PCMT Delay Time	---	---	20	ns
T_{HID}	Delay Time from BCLK Falling edge of the LSB or BCLK Rising edge following the LSB (Depending on Register TRI) to PCMT Output High Impedance	10	---	50	ns
T_{DRS}	Valid PCMR to BCLK Falling Edge Setup Time	25	---	---	ns
T_{DRH}	PCMR Hold Time from BCLK Falling Edge	20	---	---	ns

Table 8.1: PCM Timing Parameters for Non-GCI

15.2. PCM TIMING DIAGRAM FOR GCI

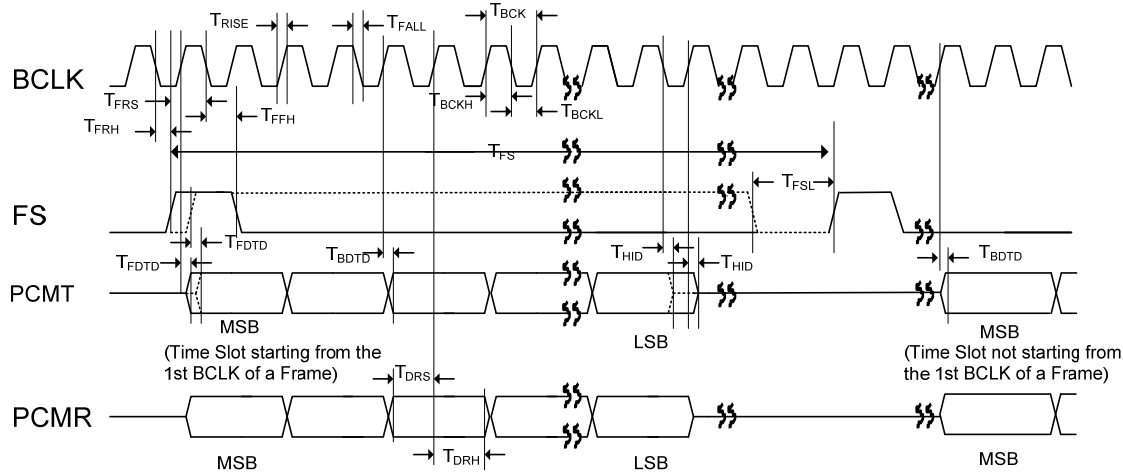

Figure 38: GCI PCM Timing

SYMBOL	DESCRIPTION	MIN	TYP	MAX	UNIT
$1/T_{FS}$	FS Frequency	---	8	---	kHz
$1/T_{BCK}$	BCLK Frequency	512	---	8192	kHz
T_{BCKH}	BCLK HIGH Pulse Width	50	---	---	ns
T_{BCKL}	BCLK LOW Pulse Width	50	---	---	ns
T_{FRH}	BCLK Falling Edge to FS Rising Edge Hold Time	20	---	---	ns
T_{FRS}	FS Rising Edge to BCLK Falling edge Setup Time	50	---	---	ns
T_{FFH}	BCLK Falling Edge to FS Falling Edge Hold Time	20	---	---	ns
T_{FDTD}	The later of BCLK or FS Rising Edge to Valid PCMT Delay Time if MSB Starts from the 1 st BCLK of a Frame	10	---	50	ns
T_{BDTD}	BCLK Rising Edge to Valid PCMT Delay Time	10	---	50	ns
T_{HID}	Delay Time from the Second BCLK Falling Edge of the LSB or the BCLK Rising Edge following LSB (Depending on Register TRI setting) to the PCMT Output High Impedance	10	---	50	ns
T_{DRS}	Valid PCMR to BCLK Rising Edge Setup Time	20	---	---	ns
T_{DRH}	PCMR Hold Time from BCLK Rising Edge	50	---	---	ns

Table 8.2: GCI Timing Parameters

SYMBOL	DESCRIPTION	MIN	TYP	MAX	UNIT	
1/T _{BCK}	BCLK Clock Frequency	---	0.256	---	---	MHz
			0.512			
			0.768			
			1.000			
			1.024			
			1.152			
			1.536			
			1.544 ⁽²⁾			
			2.000			
			2.048			
			4.000			
			4.096			
			8.000			
8.192						
T _{jitter}	BCLK Period Jitter Tolerance ⁽¹⁾	-120	---	120	ns	
T _{BCKH} / T _{BCK}	BCLK Duty Cycle for 256 kHz Operation	40%	50%	60%		
T _{BCKH}	Minimum Pulse Width HIGH for BCLK(512 kHz or Higher)	50	---	---	ns	
T _{BCKL}	Minimum Pulse Width LOW for BCLK (512 kHz or Higher)	50	---	---	ns	
T _{FRH}	BCLK falling Edge to FS Rising Edge Hold Time	50	---	---	ns	
T _{FRS}	FS Rising Edge to BCLK Falling edge Setup Time	50	---	---	ns	
T _{RISE}	Rise Time for All Digital Signals	---	---	25	ns	
T _{FALL}	Fall Time for All Digital Signals	---	---	25	ns	

Table 8.3: General PCM Timing Parameters

- 1 At 512 kHz BCLK
2. This clock is not a multiple of 256kHz or 1.000MHz. Therefore, it uses a non-integer divider.

15.3. SPI TIMING DIAGRAM

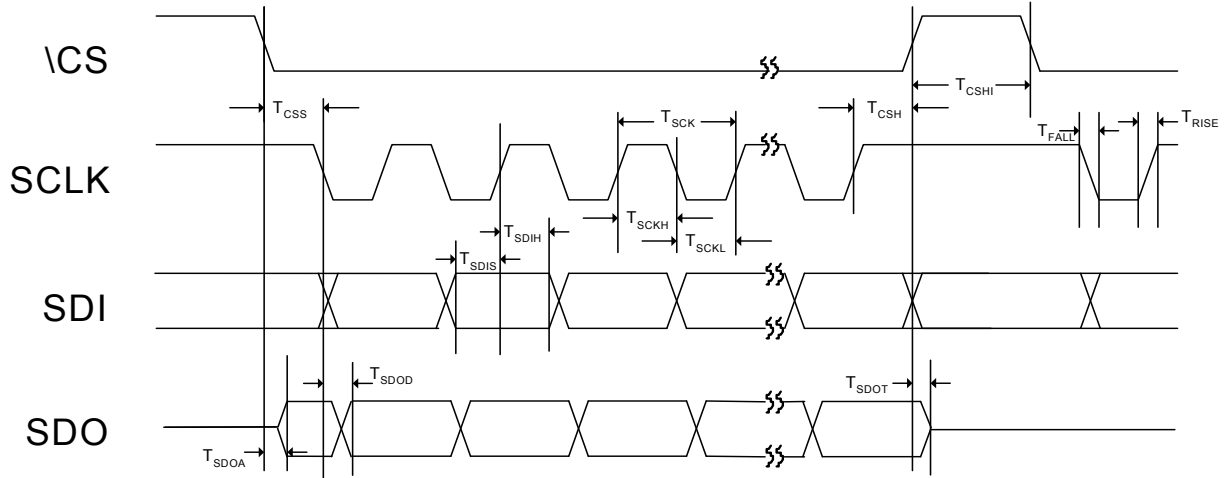

Figure 39: SPI Timing (Non-Daisy Chain Mode)

SYMBOL	DESCRIPTION	MIN	TYP	MAX	UNIT
T _{SCK}	SCLK Cycle Time	90	---	---	ns
T _{SCKH}	SCLK High Pulse Width	45	---	---	ns
T _{SCKL}	SCLK Low Pulse Width	45	---	---	ns
T _{RISE}	Rise Time for All Digital Signals	---	---	25	ns
T _{FALL}	Fall Time for All Digital Signals	---	---	25	ns
T _{CSS}	CSb Falling Edge to 1 st SCLK Falling Edge Setup Time	45	---	---	ns
T _{CSH}	Last SCLK Rising Edge to CSb Rising Edge Hold Time	45	---	---	ns
T _{CSHI}	CSb High, Delay Time between Chip Selects	200	---	---	ns
T _{SDIS}	SDI to SCLK Rising Edge Setup Time	20	---	---	ns
T _{SDIH}	SCLK Rising Edge to SDI Hold Time	20	---	---	ns
T _{SDOD}	Delay Time from SCLK Falling Edge to SDO Data	---	---	20	ns
T _{SDOT}	Delay Time from CSb Rising Edge to SDO Tri-State	---	---	10	ns
T _{SDOA}	Delay Time from CSb Falling Edge to SDO Active	---	---	10	ns

Table 8.4: General SPI Timing Parameters

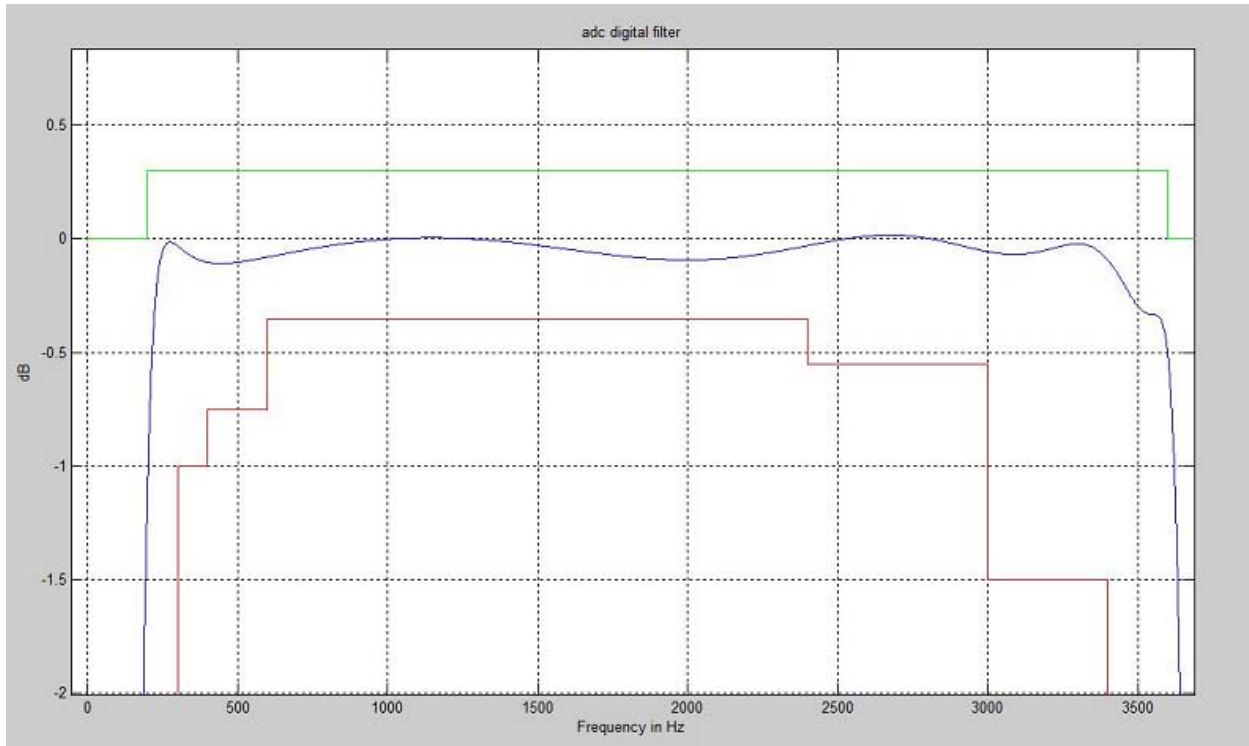

Figure 40: In-band Transmit Frequency Response

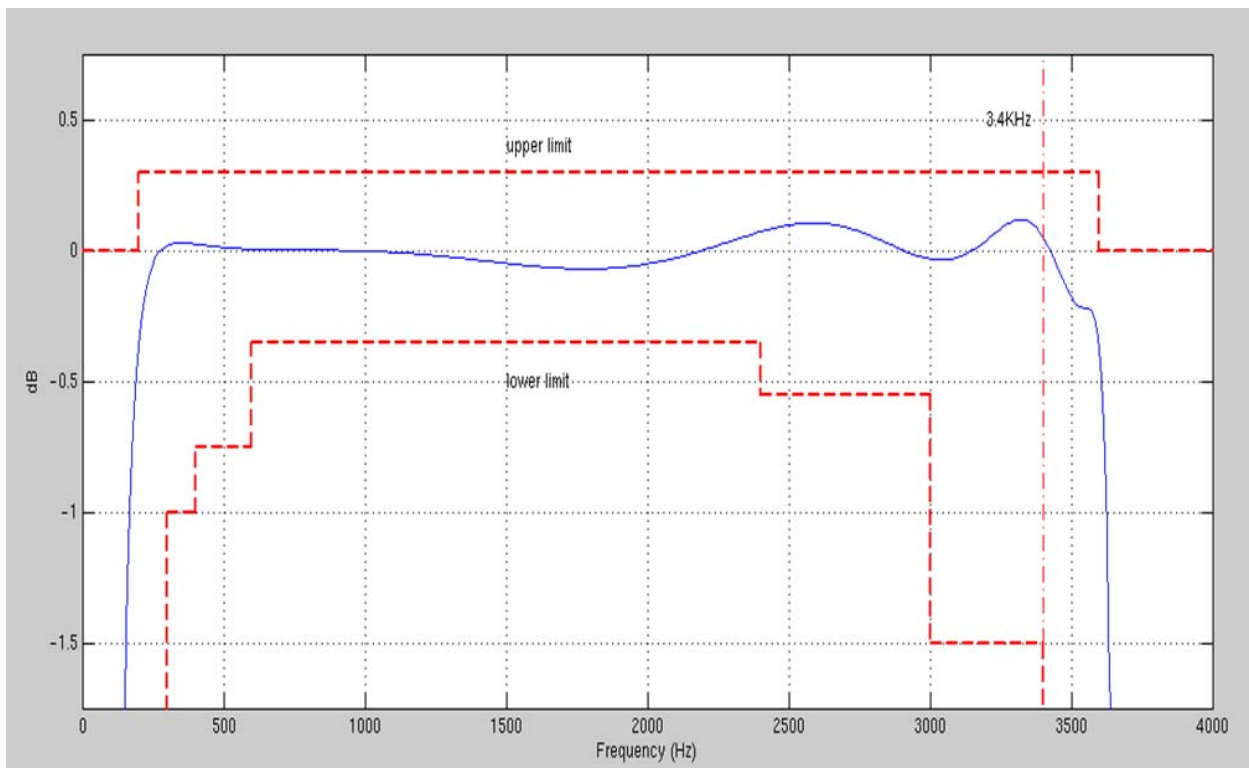

Figure 41: In-band Receive Frequency Response

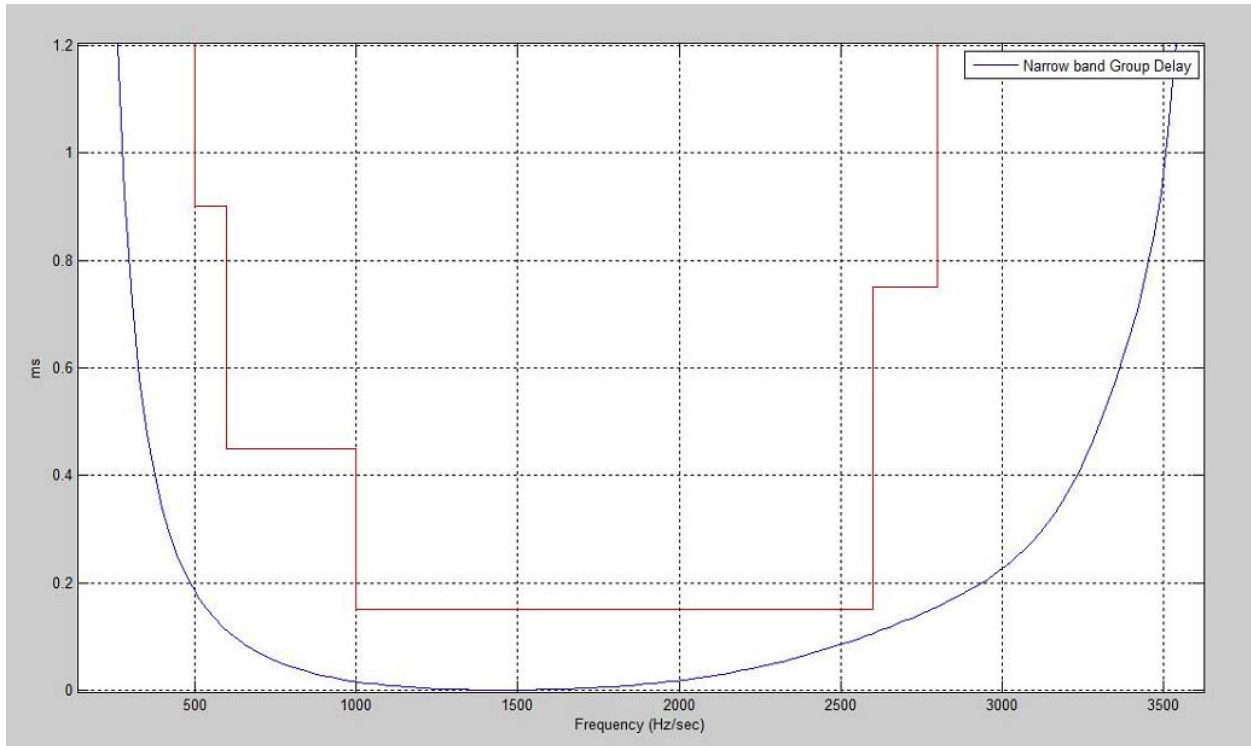

Figure 42: Transmit Group Delay Distortion

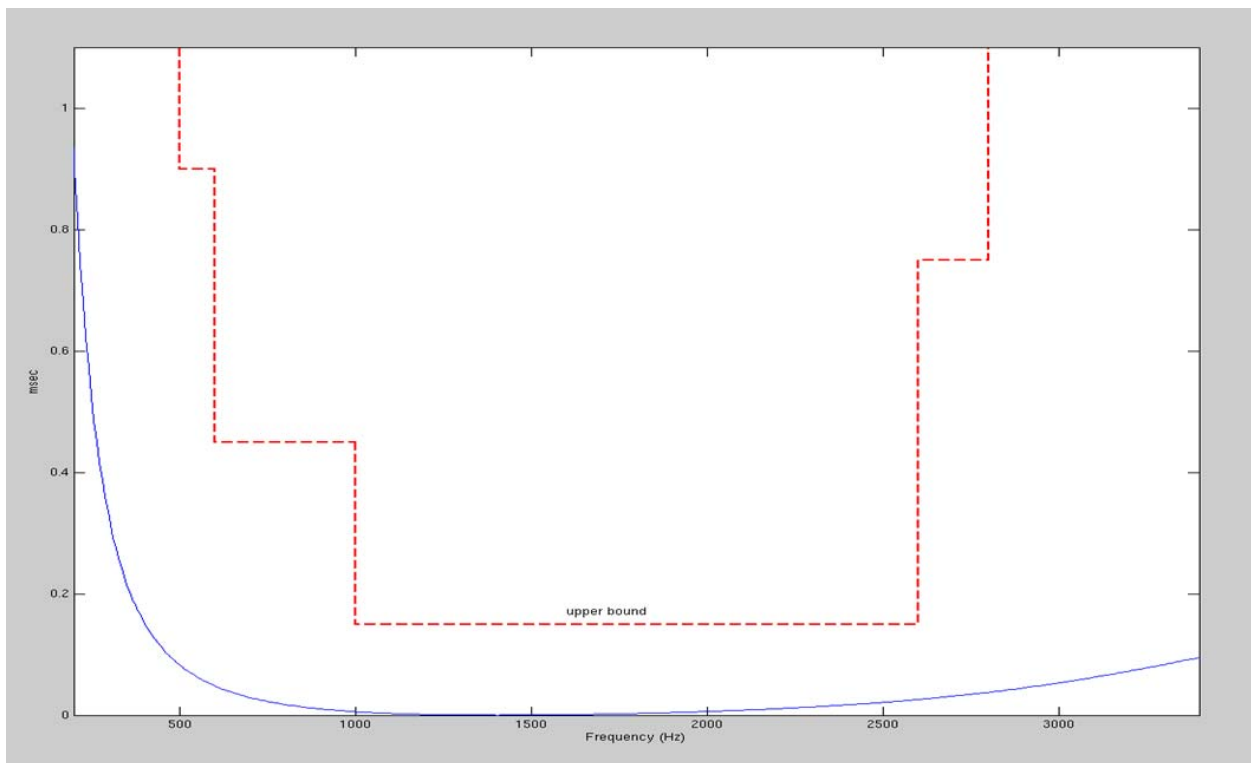

Figure 43: Receive Group Delay Distortion

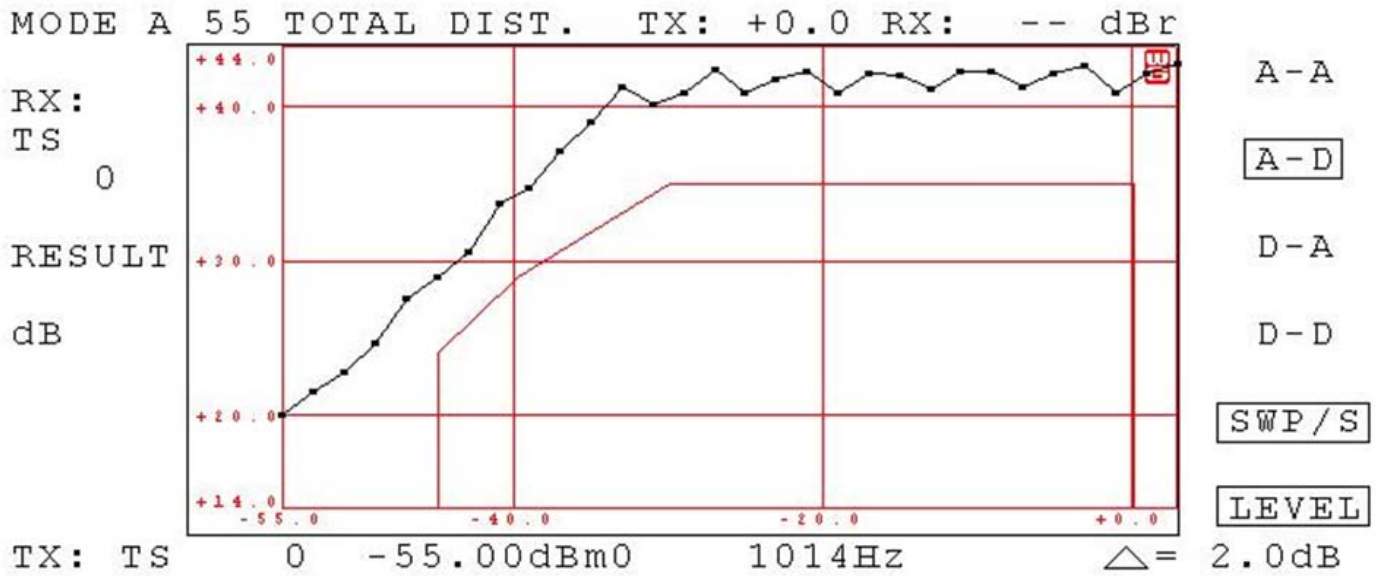

Figure 44: 2-Wire to PCM Signal to Distortion Mask (A-Law)

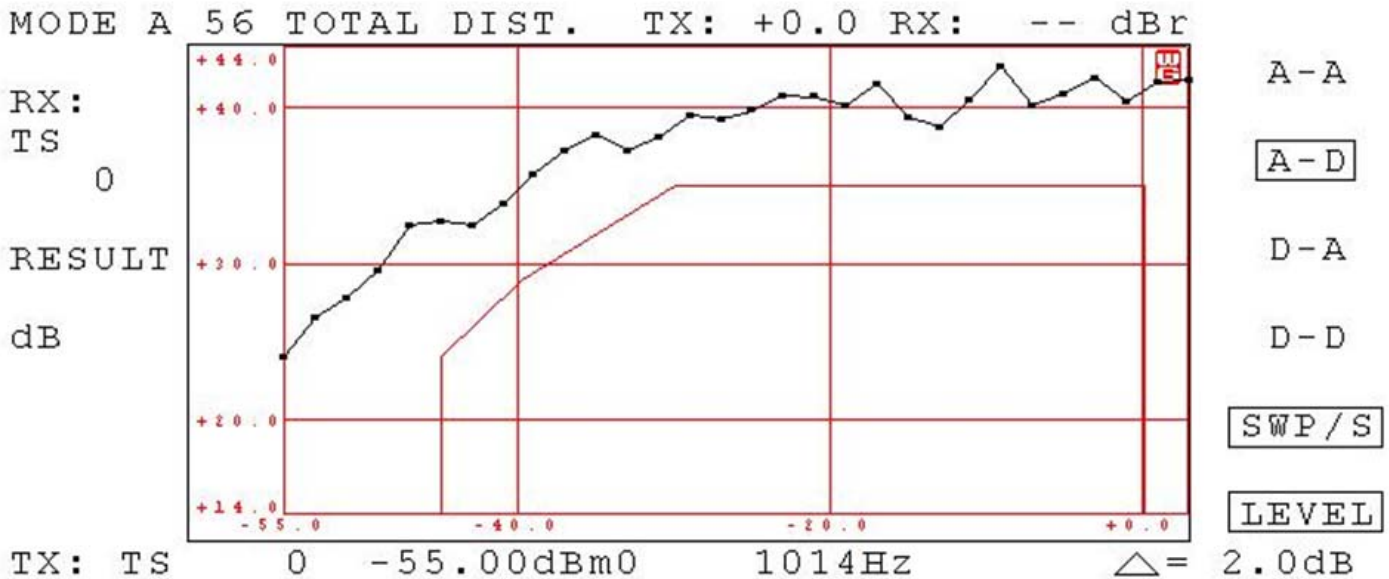

Figure 45: 2-Wire to PCM Signal to Distortion Mask (μ -Law)

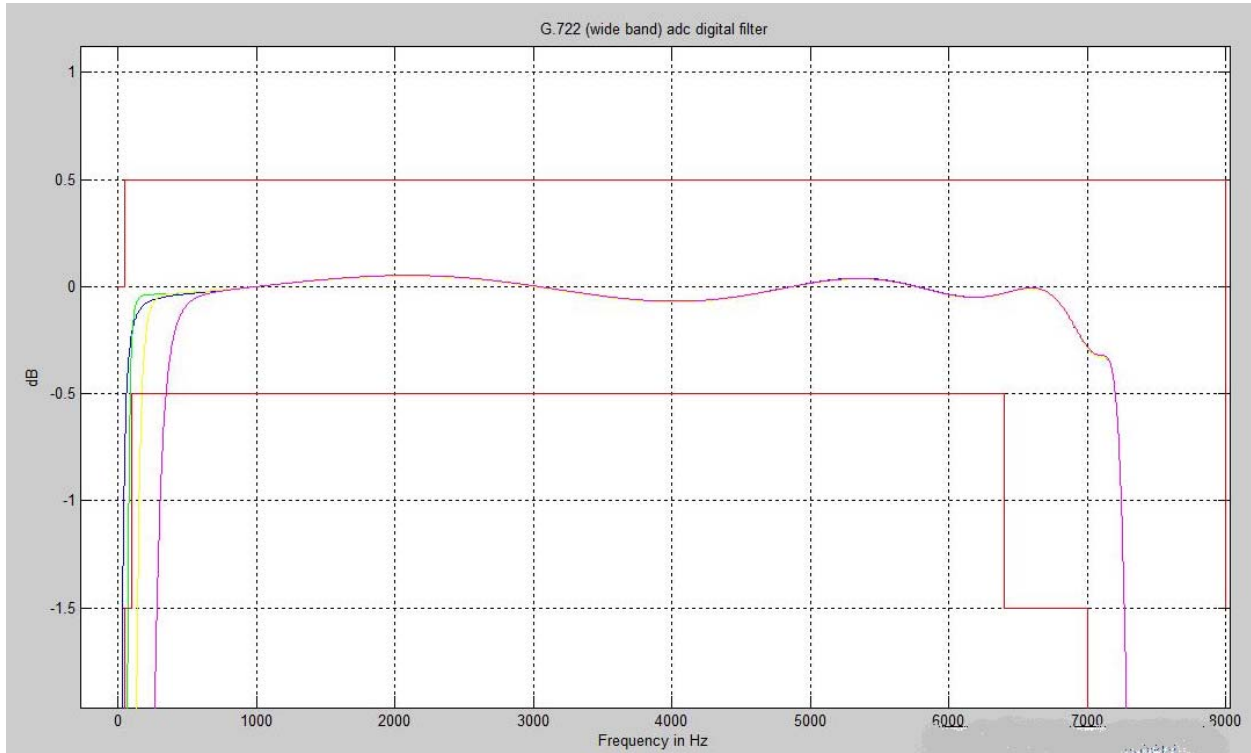

Figure 46: Wideband In-band Transmit Frequency Response

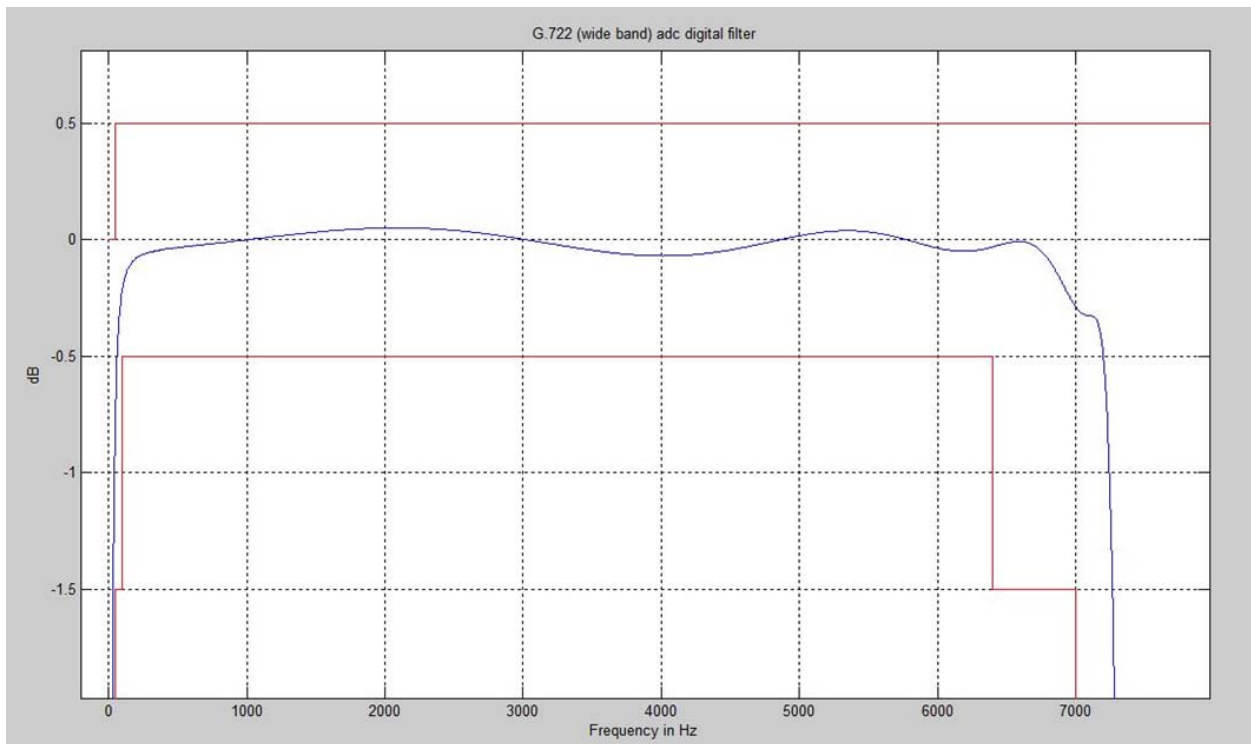

Figure 47: Wideband Transmit Group Delay Distortion

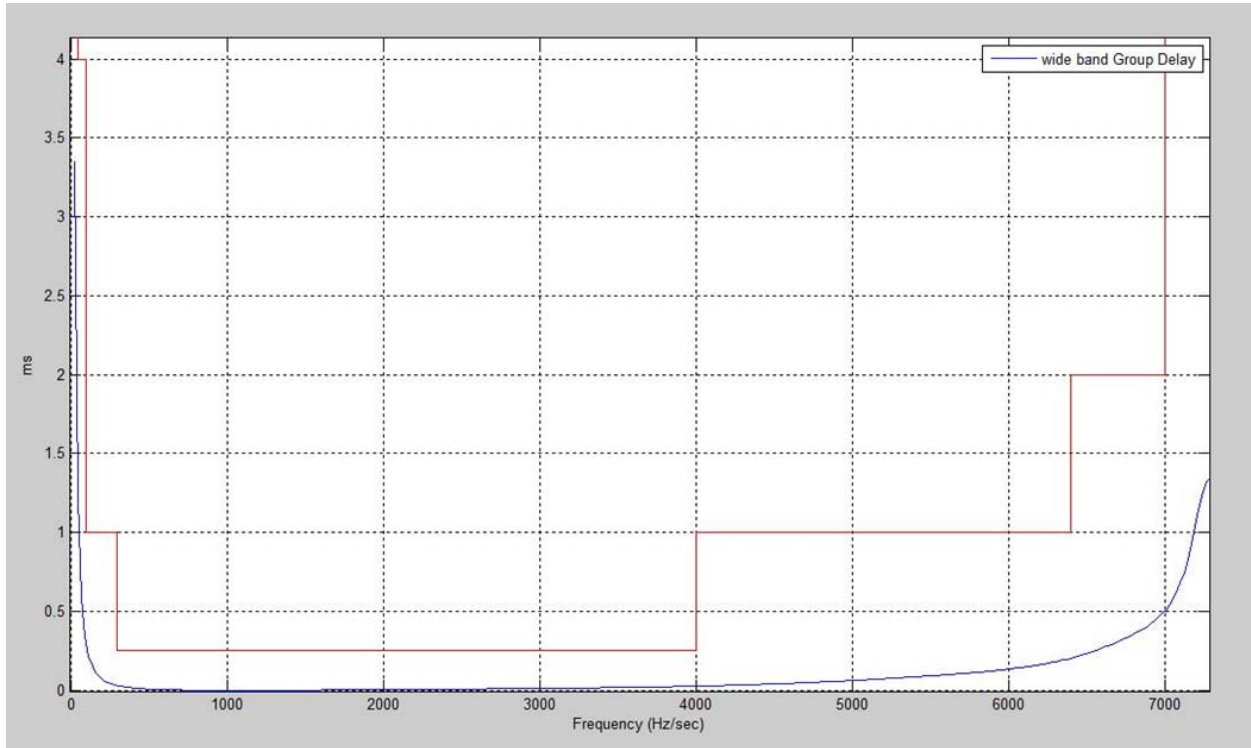

Figure 48: Wideband Receive Group Delay Distortion

16. DIGITAL I/O

16.1.1. μ -LAW ENCODE DECODE CHARACTERISTICS

Normalized Encode Decision Levels	Digital Code								Normalized Decode Levels
	D7	D6	D5	D4	D3	D2	D1	D0	
	Sign	Chord	Chord	Chord	Step	Step	Step	Step	
8159	1	0	0	0	0	0	0	0	8031
7903									:
4319	1	0	0	0	1	1	1	1	4191
4063									:
2143	1	0	0	1	1	1	1	1	2079
2015									:
1055	1	0	1	0	1	1	1	1	1023
991	1	0	1	1	1	1	1	1	495
511									:
479	1	1	0	0	1	1	1	1	231
239									:
223	1	1	0	1	1	1	1	1	99
103	1	1	1	0	1	1	1	1	33
95									:
35	1	1	1	1	1	1	1	0	2
31	1	1	1	1	1	1	1	1	0
3									
1									
0									

Notes:
Sign bit = 0 for negative values, sign bit = 1 for positive values

16.2. A-LAW ENCODE DECODE CHARACTERISTICS

Normalized Encode Decision Levels	Digital Code								Normalized Decode Levels
	D7	D6	D5	D4	D3	D2	D1	D0	
	Sign	Chord	Chord	Chord	Step	Step	Step	Step	
4096	1	0	1	0	1	0	1	0	4032
3968									:
2176	1	0	1	0	0	1	0	1	2112
2048									:
1088	1	0	1	1	0	1	0	1	1056
1024									:
544	1	0	0	0	0	1	0	1	528
512									:
272	1	0	0	1	0	1	0	1	264
256									:
136	1	1	1	0	0	1	0	1	132
128									:
68	1	1	1	0	0	1	0	1	66
64									:
2	1	1	0	1	0	1	0	1	1
0									

Notes:

1. Sign bit = 0 for negative values, sign bit = 1 for positive values
2. Digital code includes inversion of all even number bits

16.3. μ -LAW / A-LAW CODES FOR ZERO AND FULL SCALE

Level	μ -Law			A-Law		
	Sign bit (D7)	Chord bits (D6,D5,D4)	Step bits (D3,D2,D1,D0)	Sign bit (D7)	Chord bits (D6,D5,D4)	Step bits (D3,D2,D1,D0)
+ Full Scale	1	000	0000	1	010	1010
+ Zero	1	111	1111	1	101	0101
- Zero	0	111	1111	0	101	0101
- Full Scale	0	000	0000	0	010	1010

16.3.1. μ -LAW / A-LAW CODES FOR 0DBM0 OUTPUT (DIGITAL MILLIWATT)

Sample	μ -Law			A-Law		
	Sign bit (D7)	Chord bits (D6,D5,D4)	Step bits (D3,D2,D1,D0)	Sign bit (D7)	Chord bits (D6,D5,D4)	Step bits (D3,D2,D1,D0)
1	0	001	1110	0	011	0100
2	0	000	1011	0	010	0001
3	0	000	1011	0	010	0001
4	0	001	1110	0	011	0100
5	1	001	1110	1	011	0100
6	1	000	1011	1	010	0001
7	1	000	1011	1	010	0001
8	1	001	1110	1	011	0100

16.4. 16-BIT LINEAR PCM CODES FOR ZERO AND FULL SCALE

Level	Sign bit	Magnitude Bits
+ Full Scale	0	111.1111 1111 1111
+ One Step	0	000 0000 0000 0001
Zero	0	000 0000 0000 0000
- One Step	1	111 1111 1111 1111
- Full Scale	1	000 0000 0000 0000

16.5. 16-BIT LINEAR PCM CODES FOR 1 KHZ DIGITAL MILLIWATT

Phase	Sign bit	Magnitude Bits
$\pi / 8$	0	010 0001 1110 0011
$3 \pi / 8$	0	101 0001 1101 0000
$5 \pi / 8$	0	101 0001 1101 0000
$7 \pi / 8$	0	010 0001 1110 0011
$9 \pi / 8$	1	101 1110 0001 1100
$11 \pi / 8$	1	010 1110 0010 1111
$13 \pi / 8$	1	010 1110 0010 1111
$15 \pi / 8$	1	101 1110 0001 1100

17. TYPICAL APPLICATION CIRCUITS

17.1. DC/DC APPLICATION

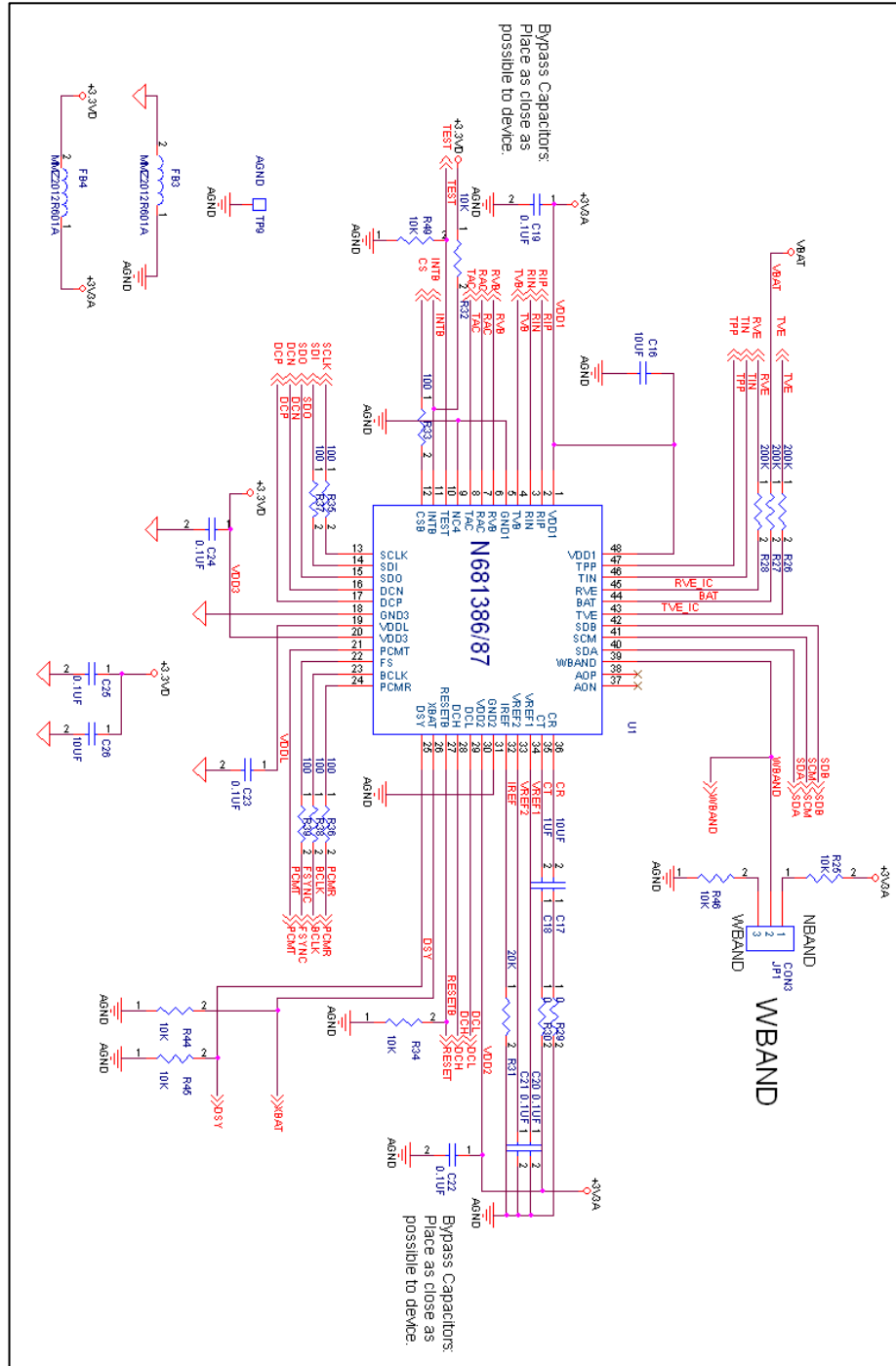

Figure 49: Typical Application Block Diagram

17.2. DISCRETE LINE DRIVER

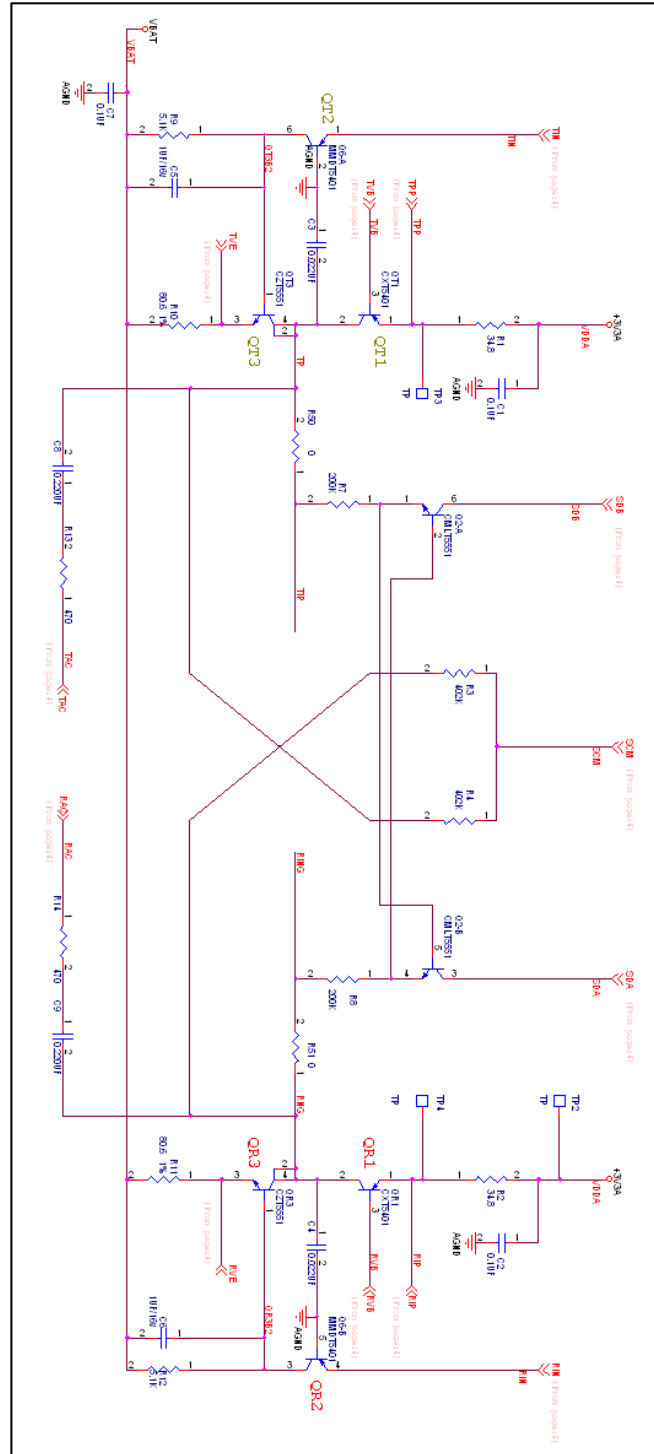

Figure 50: Discrete Line-driver

17.3. DC DC

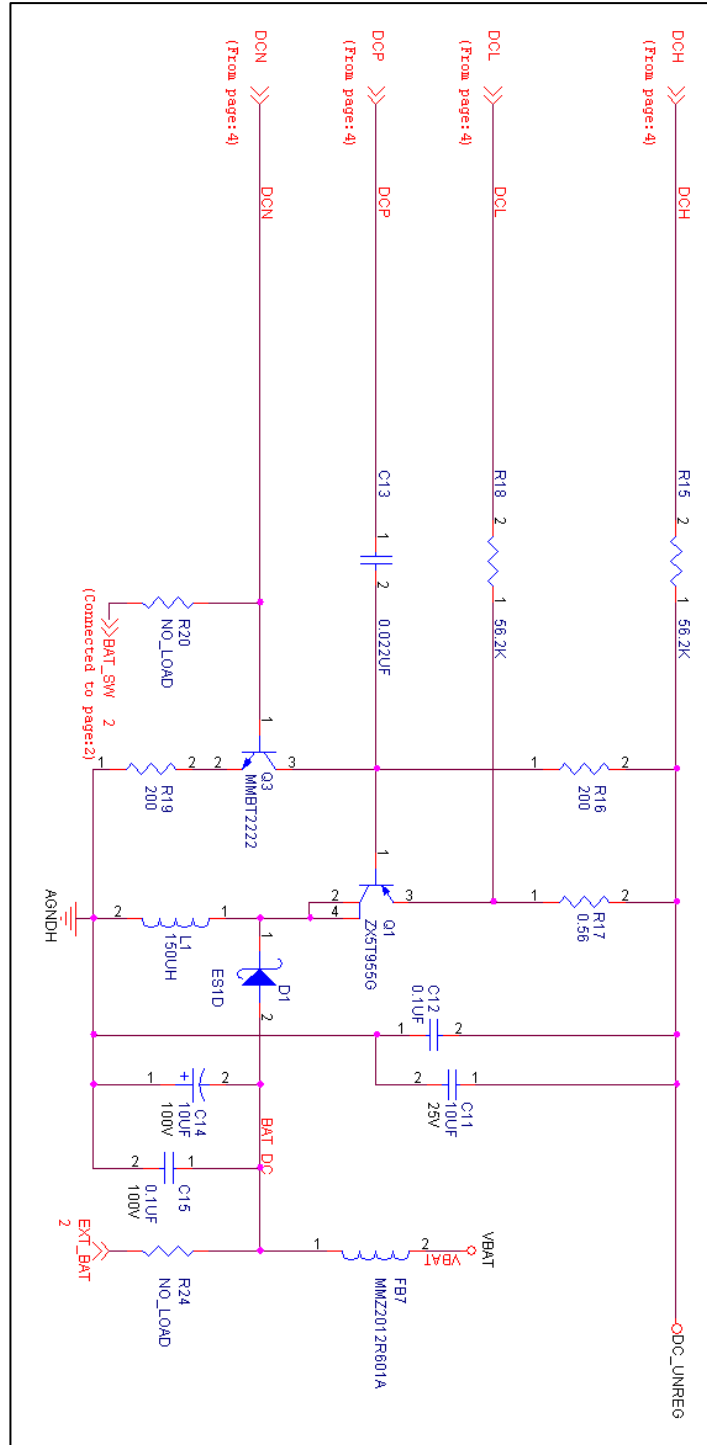

Figure 51: Inductor based circuit 12V supply

17.4. TRIPLE BATTERY SWITCH APPLICATION

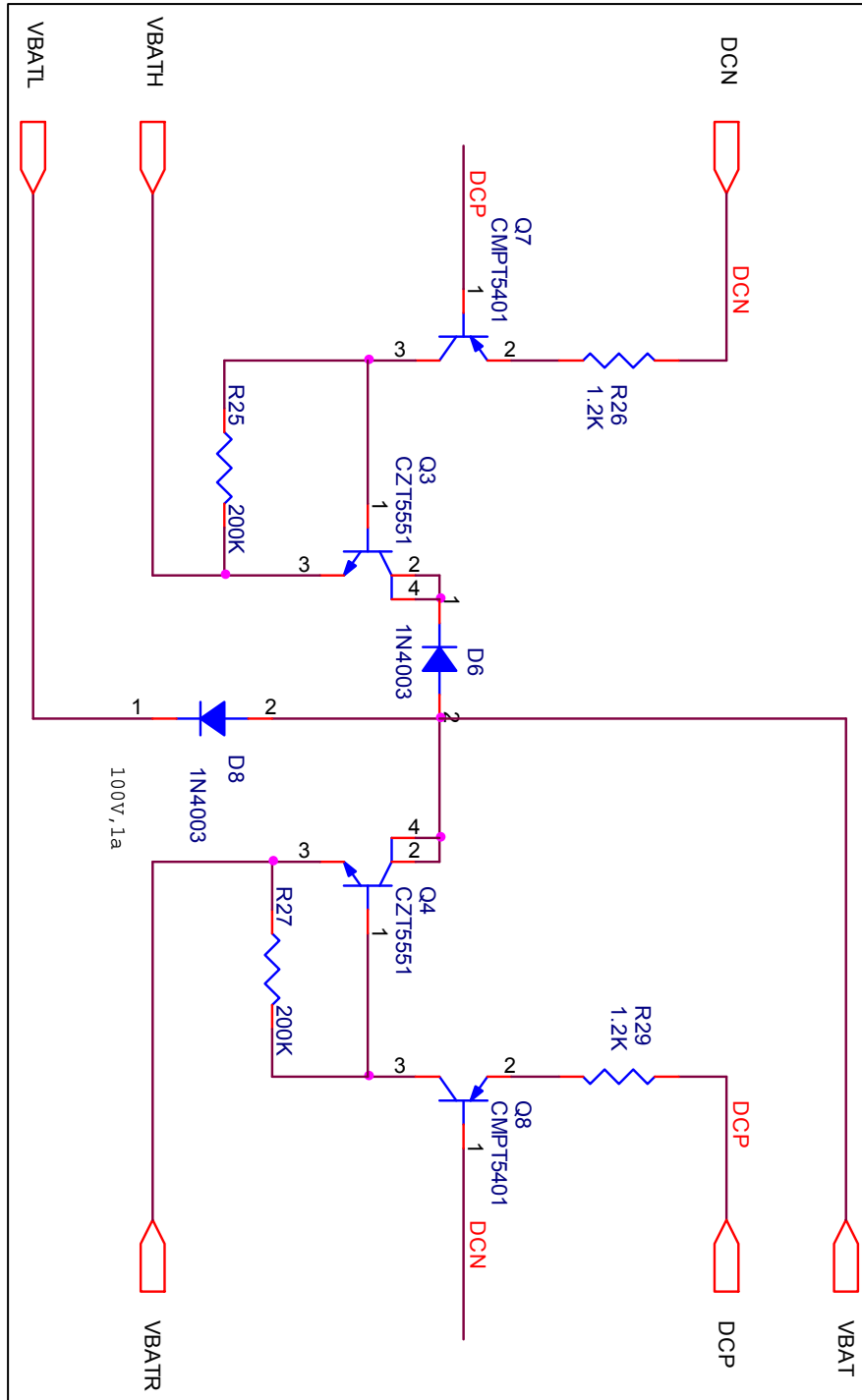
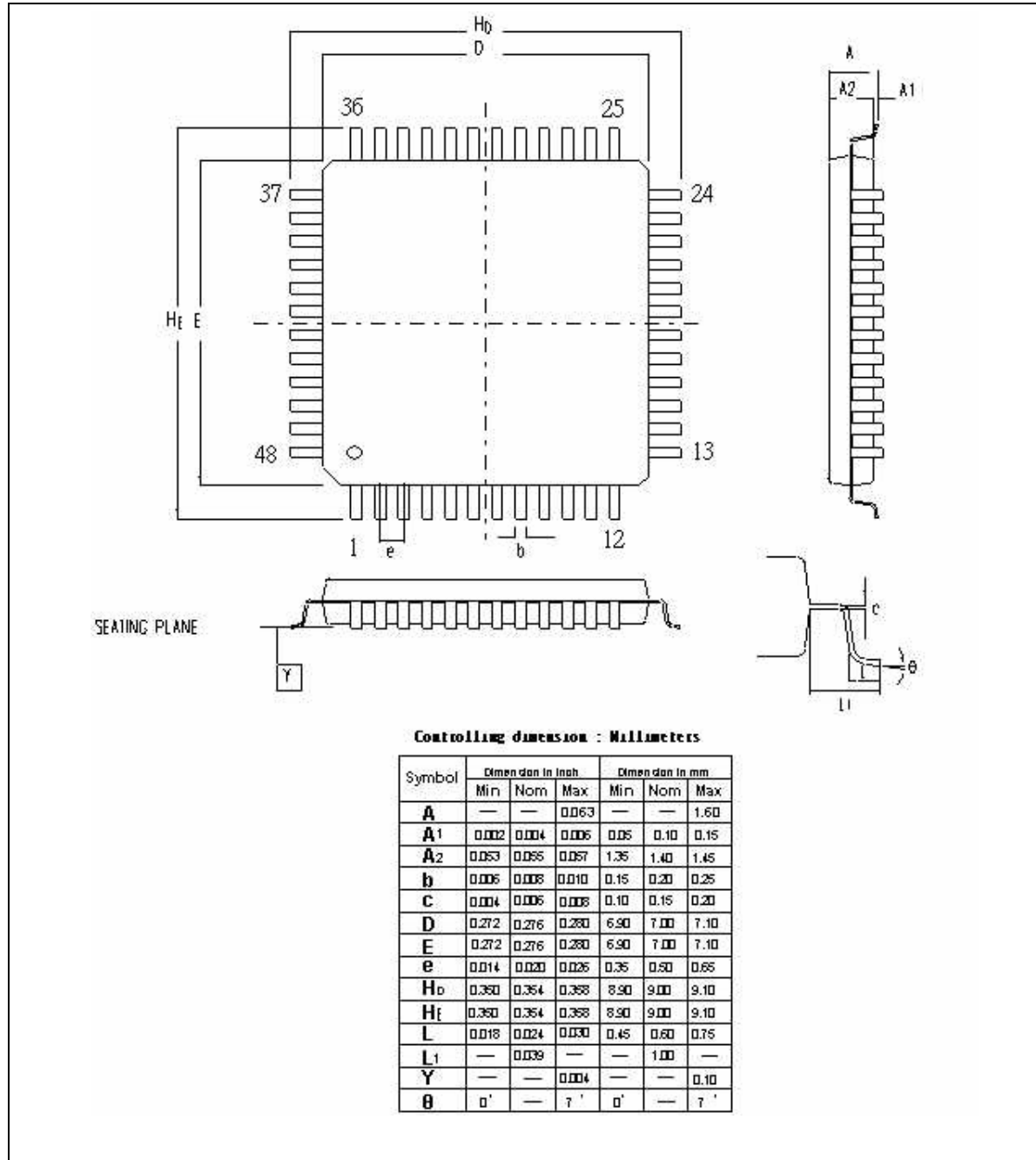

Figure 52: Triple Battery based Switch 1

18. PACKAGE SPECIFICATION

18.1. LQFP-48 (10X10X1.4mm FOOTPRINT 2.0mm)



18.2. QFN-48

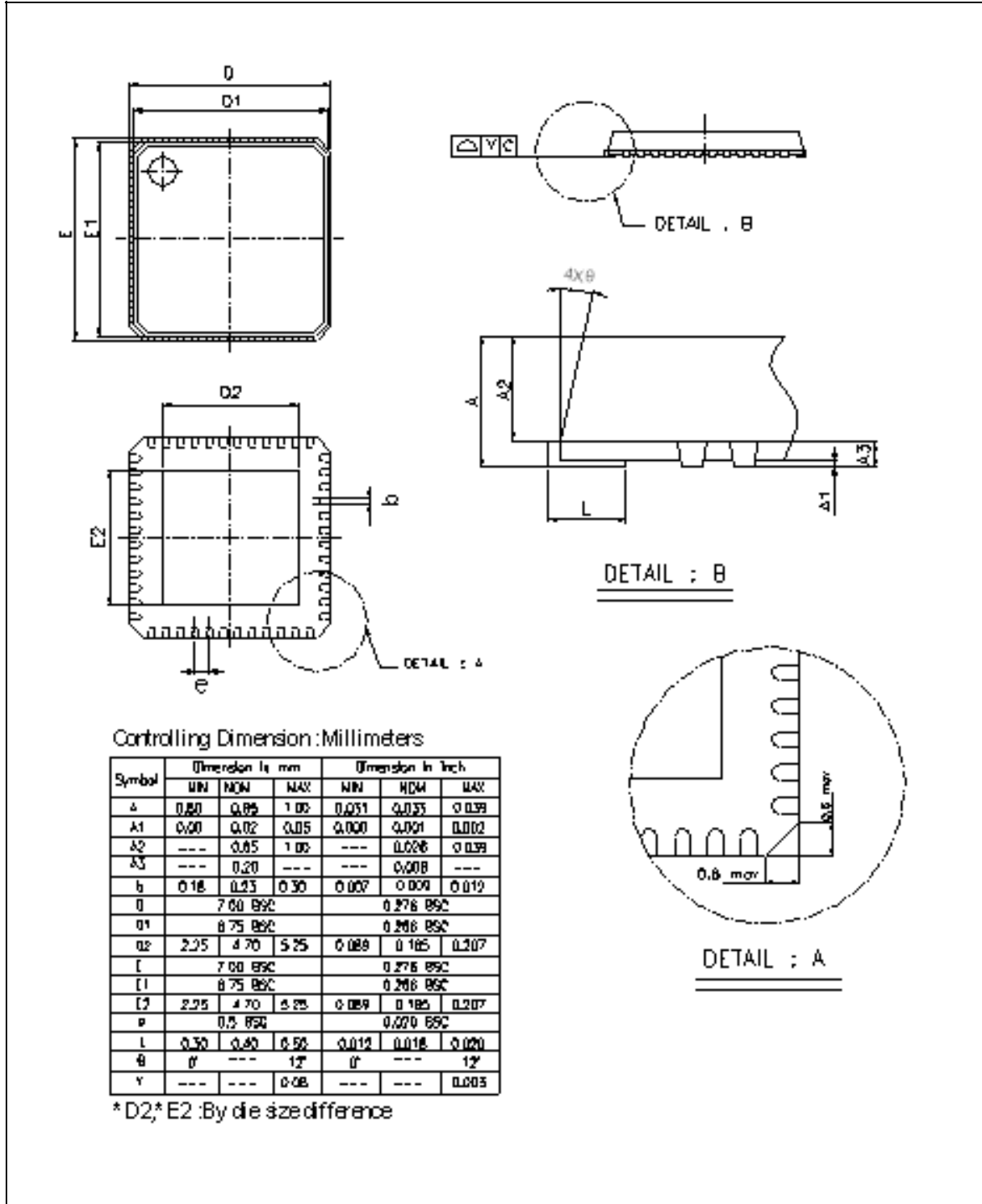

18.3. QFN 20L 4X4 mm², PITCH:0.50 mm

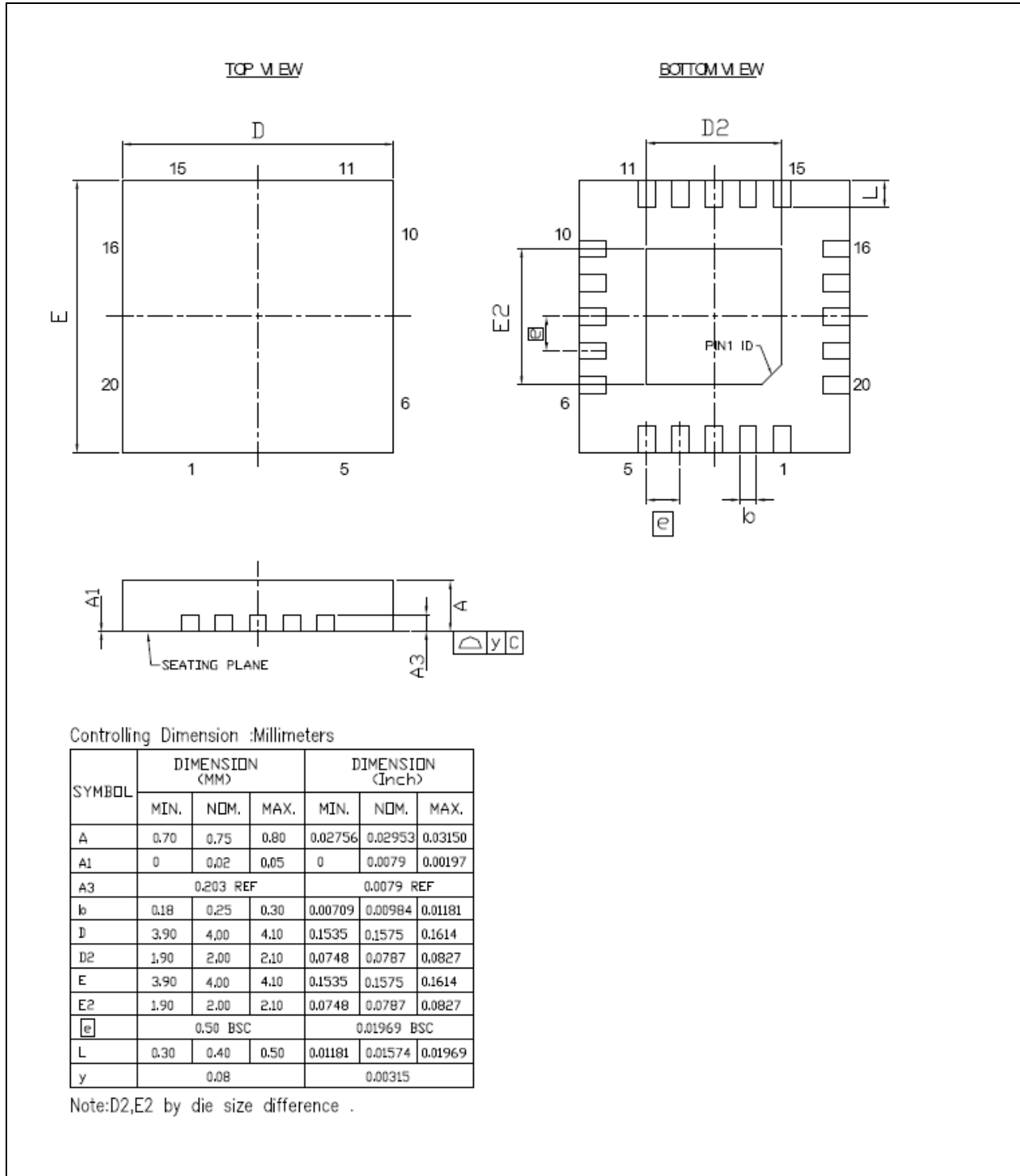

19. ORDERING INFORMATION

Nuvoton Part Number Description

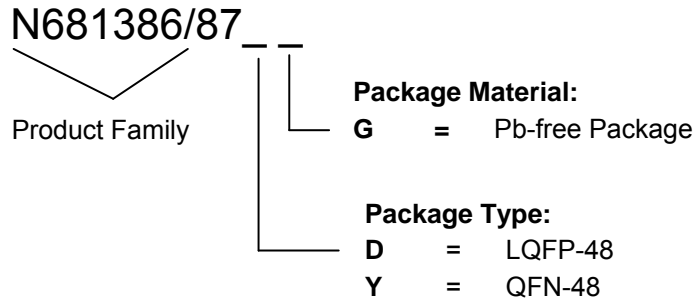

When ordering N681386/87 series devices, please refer to the following part numbers:

Part Number	Temp Range (°C)	Package	Package Material
N681386DG N681387DG	-40 to 85	48-LQFP	Pb-Free
N681386YG N681387YG	-40 to 85	48-QFN	Pb-Free

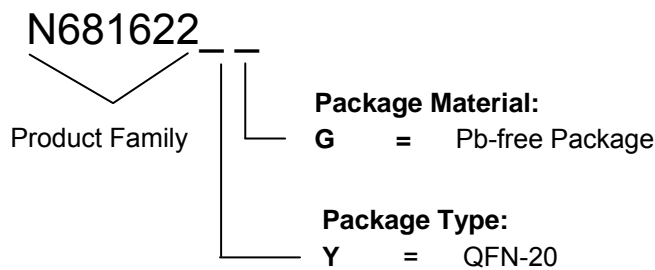

When ordering N681622 series devices, please refer to the following part numbers:

Part Number	Temp Range (°C)	Package	Package Material
N681622YG	-40 to 85	20-QFN	Pb-Free

20. VERSION HISTORY

VERSION	DATE	PAGE	DESCRIPTION
V0.85	January 2010		Register 0x0F deleted from the document.
		1	Package info updated
		33	Table 10 updated
		37	Table 14 has been deleted from the document
		50	Figure 17 updated
		52	Equations updated. Table 22 has been deleted from the document
		62	External battery switching detail updated
		67	General Description for N681622 updated
		77 & 96	Register table address 0x24 updated
		86	Register 0x10[1] description updated
		88 & 77	Register 0x14 updated
		96	Register 0x26 info updated
		102 -103	Registers 0x36, 0x37, and 0x38 units updated
		105	Register 0x41 info updated
134	Register 0xB6 has been deleted from the document		
135	Register info updated. Register 0xC0 bit description updated		
V1.0	January 2010	18 – 24	Location of the tables were modified
		18	Absolute Maximum Ratings table for N681622 updated
		20	IPD and ISB maximum values updated
		21	Supply parameter for SLFC updated
		31	Tables 8 and 9 updated
		35	Example updated
		36	Table 15 updated
		40	Table 15 updated
		49	Register 0x60 and 0x61 updated
		56	Impedance matching section updated
		59	Diagnostics Support description updated
		64	PCM Interface description updated
		67	PLL and Prescaler in Wideband table updated
		74	SPI 12-bits Read sequence diagram updated
		82	Register 0x03 default updated
		85	Register 0x06 and 0x07 updated
86	Register 0x10[1] description updated		
88 - 92	Register 0x15 to 0x1F description updated		
89	Register 0x15 to 0x1F updated		

VERSION	DATE	PAGE	DESCRIPTION
		93	Register 0x20 updated
		94	Register 0x22 info updated
		107	Register 0x43 info updated
		111	Register 0x4C info updated
		115	Register 0x5E to 0x61 info updated
		122 - 128	Register 0x81 to 0x9C updated
		129	Register 0x9D and 0x9E deleted from the document
		131	Register 0xAD info updated
		136	Register 0xDA and 0xDB deleted from the document
		139	Register 0xF7 description updated
		153	Application Diagrams updated

Important Notice

Nuvoton products are not designed, intended, authorized or warranted for use as components in systems or equipment intended for surgical implantation, atomic energy control instruments, airplane or spaceship instruments, transportation instruments, traffic signal instruments, combustion control instruments, or for other applications intended to support or sustain life. Furthermore, Nuvoton products are not intended for applications wherein failure of Nuvoton products could result or lead to a situation wherein personal injury, death or severe property or environmental damage could occur.

Nuvoton customers using or selling these products for use in such applications do so at their own risk and agree to fully indemnify Nuvoton for any damages resulting from such improper use or sales.

Looking for pricing, stock, or lifecycle information?

Click below to explore more details on WIN SOURCE:

- [⊖ View N681387DG TR on WIN SOURCE](#)
- [⊖ Nuvoton Technology Corporation of America Information](#)

Optimize Your Supply Chain with WIN SOURCE Solutions

- ✓ Global Sourcing Solution
- ✓ Obsolete Management
- ✓ Cost Control Management
- ✓ Shortage Management
- ✓ Alternative Solution
- ✓ Excess Inventory Management