



**THE DATASHEET OF  
MW7IC2725NR1**



# RF LDMOS Wideband Integrated Power Amplifiers

The MW7IC2725N wideband integrated circuit is designed with on-chip matching that makes it usable from 2300- 2700 MHz. This multi-stage structure is rated for 26 to 32 Volt operation and covers all typical cellular base station modulation formats.

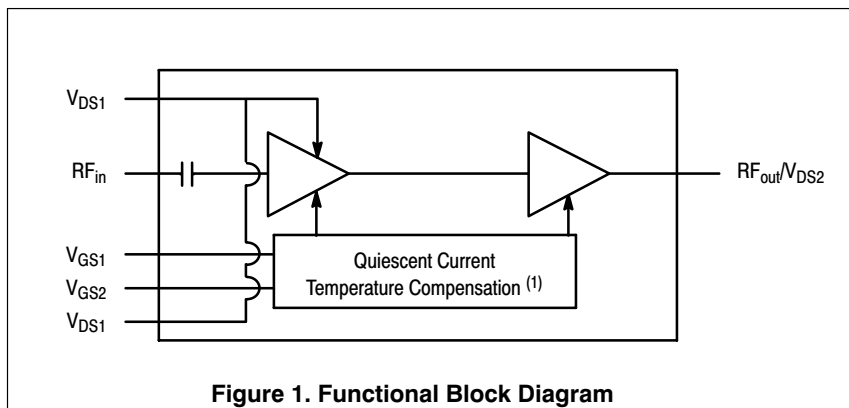
- Typical WiMAX Performance:  $V_{DD} = 28$  Volts,  $I_{DQ1} = 77$  mA,  $I_{DQ2} = 275$  mA,  $P_{out} = 4$  Watts Avg.,  $f = 2700$  MHz, OFDM 802.16d, 64 QAM  $3/4$ , 4 Bursts, 10 MHz Channel Bandwidth, Input Signal PAR = 9.5 dB @ 0.01% Probability on CCDF.  
 Power Gain — 28.5 dB  
 Power Added Efficiency — 17%  
 Device Output Signal PAR — 9 dB @ 0.01% Probability on CCDF  
 ACPR @ 8.5 MHz Offset — -50 dBc in 1 MHz Channel Bandwidth

## Driver Applications

- Typical WiMAX Performance:  $V_{DD} = 28$  Volts,  $I_{DQ1} = 77$  mA,  $I_{DQ2} = 275$  mA,  $P_{out} = 26$  dBm Avg.,  $f = 2700$  MHz, OFDM 802.16d, 64 QAM  $3/4$ , 4 Bursts, 10 MHz Channel Bandwidth, Input Signal PAR = 9.5 dB @ 0.01% Probability on CCDF.  
 Power Gain — 27.8 dB  
 Power Added Efficiency — 3.2%  
 Device Output Signal PAR — 9 dB @ 0.01% Probability on CCDF  
 ACPR @ 8.5 MHz Offset — -56 dBc in 1 MHz Channel Bandwidth
- Capable of Handling 10:1 VSWR, @ 32 Vdc, 2600 MHz, 40 Watts CW Output Power (3 dB Input Overdrive from Rated  $P_{out}$ )
- Stable into a 5:1 VSWR. All Spurs Below -60 dBc @ 100 mW to 5 W CW  $P_{out}$
- Typical  $P_{out}$  @ 1 dB Compression Point  $\approx$  25 Watts CW

## Features

- 100% PAR Tested for Guaranteed Output Power Capability
- Characterized with Series Equivalent Large-Signal Impedance Parameters and Common Source S-Parameters
- On-Chip Matching (50 Ohm Input, DC Blocked)
- Integrated Quiescent Current Temperature Compensation with Enable/Disable Function (1)
- Integrated ESD Protection
- 225°C Capable Plastic Package
- RoHS Compliant
- In Tape and Reel. R1 Suffix = 500 Units per 44 mm, 13 inch Reel.



**Figure 1. Functional Block Diagram**

1. Refer to AN1977, *Quiescent Current Thermal Tracking Circuit in the RF Integrated Circuit Family* and to AN1987, *Quiescent Current Control for the RF Integrated Circuit Device Family*. Go to <http://www.freescale.com/rf>. Select Documentation/Application Notes - AN1977 or AN1987.

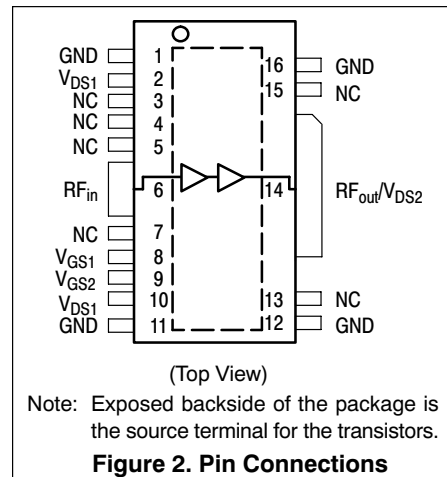
**MW7IC2725NR1**  
**MW7IC2725GNR1**  
**MW7IC2725NBR1**

**2500-2700 MHz, 4 W AVG., 28 V**  
**WiMAX**  
**RF LDMOS WIDEBAND**  
**INTEGRATED POWER AMPLIFIERS**

**CASE 1886-01**  
**TO-270 WB-16**  
**PLASTIC**  
**MW7IC2725NR1**

**CASE 1887-01**  
**TO-270 WB-16 GULL**  
**PLASTIC**  
**MW7IC2725GNR1**

**CASE 1329-09**  
**TO-272 WB-16**  
**PLASTIC**  
**MW7IC2725NBR1**



**Table 1. Maximum Ratings**

Rating	Symbol	Value	Unit
Drain-Source Voltage	$V_{DS}$	-0.5, +65	Vdc
Gate-Source Voltage	$V_{GS}$	-0.5, +10	Vdc
Operating Voltage	$V_{DD}$	32, +0	Vdc
Storage Temperature Range	$T_{stg}$	-65 to +150	°C
Case Operating Temperature	$T_C$	150	°C
Operating Junction Temperature (1,2)	$T_J$	225	°C
Input Power	$P_{in}$	22	dBm

**Table 2. Thermal Characteristics**

Characteristic	Symbol	Value (2,3)	Unit
Thermal Resistance, Junction to Case	$R_{\theta JC}$		°C/W
WiMAX Application (Case Temperature 75°C, $P_{out} = 4$ W Avg.)		Stage 1, 28 Vdc, $I_{DQ1} = 77$ mA Stage 2, 28 Vdc, $I_{DQ2} = 275$ mA	5.9 1.4
CW Application (Case Temperature 81°C, $P_{out} = 25$ W CW)		Stage 1, 28 Vdc, $I_{DQ1} = 77$ mA Stage 2, 28 Vdc, $I_{DQ2} = 275$ mA	5.5 1.3

**Table 3. ESD Protection Characteristics**

Test Methodology	Class
Human Body Model (per JESD22-A114)	1B (Minimum)
Machine Model (per EIA/JESD22-A115)	A (Minimum)
Charge Device Model (per JESD22-C101)	II (Minimum)

**Table 4. Moisture Sensitivity Level**

Test Methodology	Rating	Package Peak Temperature	Unit
Per JESD22-A113, IPC/JEDEC J-STD-020	3	260	°C

**Table 5. Electrical Characteristics** ( $T_A = 25^\circ\text{C}$  unless otherwise noted)

Characteristic	Symbol	Min	Typ	Max	Unit
<b>Stage 1 - Off Characteristics</b>					
Zero Gate Voltage Drain Leakage Current ( $V_{DS} = 65$ Vdc, $V_{GS} = 0$ Vdc)	$I_{DSS}$	—	—	10	$\mu\text{Adc}$
Zero Gate Voltage Drain Leakage Current ( $V_{DS} = 28$ Vdc, $V_{GS} = 0$ Vdc)	$I_{DSS}$	—	—	1	$\mu\text{Adc}$
Gate-Source Leakage Current ( $V_{GS} = 1.5$ Vdc, $V_{DS} = 0$ Vdc)	$I_{GSS}$	—	—	1	$\mu\text{Adc}$
<b>Stage 1 - On Characteristics</b>					
Gate Threshold Voltage ( $V_{DS} = 10$ Vdc, $I_D = 20$ $\mu\text{Adc}$ )	$V_{GS(th)}$	1.2	1.9	2.7	Vdc
Gate Quiescent Voltage ( $V_{DS} = 28$ Vdc, $I_{DQ1} = 77$ mA)	$V_{GS(Q)}$	—	2.7	—	Vdc
Fixture Gate Quiescent Voltage ( $V_{DD} = 28$ Vdc, $I_{DQ1} = 77$ mA, Measured in Functional Test)	$V_{GG(Q)}$	12.5	15.8	19.5	Vdc

1. Continuous use at maximum temperature will affect MTTF.
2. MTTF calculator available at <http://www.freescale.com/rf>. Select Software & Tools/Development Tools/Calculators to access MTTF calculators by product.
3. Refer to AN1955, *Thermal Measurement Methodology of RF Power Amplifiers*. Go to <http://www.freescale.com/rf>. Select Documentation/Application Notes - AN1955.

(continued)

**Table 5. Electrical Characteristics** ( $T_A = 25^\circ\text{C}$  unless otherwise noted) (continued)

Characteristic	Symbol	Min	Typ	Max	Unit
<b>Stage 2 - Off Characteristics</b>					
Zero Gate Voltage Drain Leakage Current ( $V_{DS} = 65\text{ Vdc}$ , $V_{GS} = 0\text{ Vdc}$ )	$I_{DSS}$	—	—	10	$\mu\text{Adc}$
Zero Gate Voltage Drain Leakage Current ( $V_{DS} = 28\text{ Vdc}$ , $V_{GS} = 0\text{ Vdc}$ )	$I_{DSS}$	—	—	1	$\mu\text{Adc}$
Gate-Source Leakage Current ( $V_{GS} = 1.5\text{ Vdc}$ , $V_{DS} = 0\text{ Vdc}$ )	$I_{GSS}$	—	—	1	$\mu\text{Adc}$

**Stage 2 - On Characteristics**

Gate Threshold Voltage ( $V_{DS} = 10\text{ Vdc}$ , $I_D = 80\ \mu\text{Adc}$ )	$V_{GS(th)}$	1.2	1.9	2.7	Vdc
Gate Quiescent Voltage ( $V_{DS} = 28\text{ Vdc}$ , $I_{DQ2} = 275\text{ mAdc}$ )	$V_{GS(Q)}$	—	2.7	—	Vdc
Fixture Gate Quiescent Voltage ( $V_{DD} = 28\text{ Vdc}$ , $I_{DQ2} = 275\text{ mAdc}$ , Measured in Functional Test)	$V_{GG(Q)}$	11	14	18	Vdc
Drain-Source On-Voltage ( $V_{GS} = 10\text{ Vdc}$ , $I_D = 800\text{ mAdc}$ )	$V_{DS(on)}$	0.15	0.47	0.8	Vdc

**Stage 2 - Dynamic Characteristics** (1)

Output Capacitance ( $V_{DS} = 28\text{ Vdc} \pm 30\text{ mV(rms)ac}$ @ 1 MHz, $V_{GS} = 0\text{ Vdc}$ )	$C_{oss}$	—	111	—	pF
---	-----------	---	-----	---	----

**Functional Tests** (In Freescale Test Fixture, 50 ohm system)  $V_{DD} = 28\text{ Vdc}$ ,  $I_{DQ1} = 77\text{ mA}$ ,  $I_{DQ2} = 275\text{ mA}$ ,  $P_{out} = 4\text{ W Avg.}$ ,  $f = 2700\text{ MHz}$ , WiMAX, OFDM 802.16d, 64 QAM  $^{3/4}$ , 4 Bursts, 10 MHz Channel Bandwidth, Input Signal PAR = 9.5 dB @ 0.01% Probability on CCDF. ACPR measured in 1 MHz Channel Bandwidth @  $\pm 8.5\text{ MHz}$  Offset.

Power Gain	$G_{ps}$	25.5	28.5	30.5	dB
Power Added Efficiency	PAE	15	17	—	%
Output Peak-to-Average Ratio @ 0.01% Probability on CCDF	PAR	—	9	—	dB
Adjacent Channel Power Ratio	ACPR	—	-50	-46	dBc
Input Return Loss	IRL	—	-15	-10	dB

**Typical Performances OFDM Signal - 10 MHz Channel Bandwidth** (In Freescale Test Fixture, 50 ohm system)  $V_{DD} = 28\text{ Vdc}$ ,  $I_{DQ1} = 77\text{ mA}$ ,  $I_{DQ2} = 275\text{ mA}$ ,  $P_{out} = 4\text{ W Avg.}$ ,  $f = 2700\text{ MHz}$ , WiMAX, OFDM 802.16d, 64 QAM  $^{3/4}$ , 4 Bursts, 10 MHz Channel Bandwidth, Input Signal PAR = 9.5 dB @ 0.01% Probability on CCDF.

Relative Constellation Error (2)	RCE	—	-33	—	dB
Error Vector Magnitude (2)	EVM	—	2.2	—	% rms

- Part internally matched both on input and output.
- RCE =  $20\text{Log}(EVM/100)$

(continued)

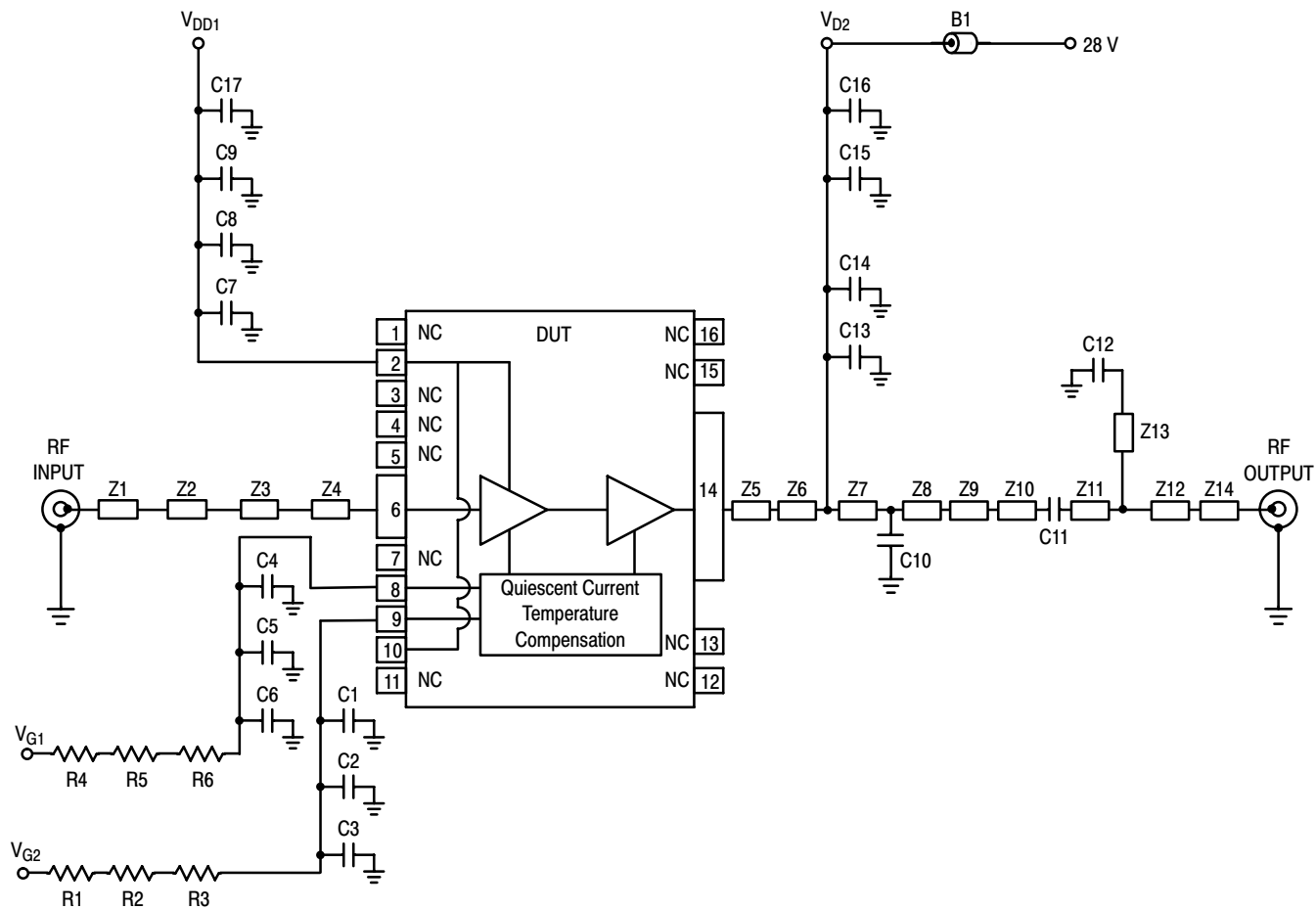
**Table 5. Electrical Characteristics** ( $T_A = 25^\circ\text{C}$  unless otherwise noted) (continued)

Characteristic	Symbol	Min	Typ	Max	Unit
<b>Typical Performances</b> (In Freescale Test Fixture, 50 ohm system) $V_{DD} = 28\text{ Vdc}$ , $I_{DQ1} = 77\text{ mA}$ , $I_{DQ2} = 275\text{ mA}$ , 2500- 2700 MHz Bandwidth					
$P_{out}$ @ 1 dB Compression Point, CW	P1dB	—	25	—	W
IMD Symmetry @ 27 W PEP, $P_{out}$ where IMD Third Order Intermodulation $\cong 30\text{ dBc}$ (Delta IMD Third Order Intermodulation between Upper and Lower Sidebands $> 2\text{ dB}$ )	IMD <sub>sym</sub>	—	50	—	MHz
VBW Resonance Point (IMD Third Order Intermodulation Inflection Point)	VBW <sub>res</sub>	—	90	—	MHz
Gain Flatness in 200 MHz Bandwidth @ $P_{out} = 4\text{ W Avg.}$	$G_F$	—	0.5	—	dB
Average Deviation from Linear Phase in 200 MHz Bandwidth @ $P_{out} = 25\text{ W CW}$	$\Phi$	—	2.1	—	$^\circ$
Average Group Delay @ $P_{out} = 25\text{ W CW}$ , $f = 2600\text{ MHz}$	Delay	—	2.3	—	ns
Part-to-Part Insertion Phase Variation @ $P_{out} = 25\text{ W CW}$ , $f = 2600\text{ MHz}$ , Six Sigma Window	$\Delta\Phi$	—	22	—	$^\circ$
Gain Variation over Temperature ( $-30^\circ\text{C}$ to $+85^\circ\text{C}$ )	$\Delta G$	—	0.036	—	dB/ $^\circ\text{C}$
Output Power Variation over Temperature ( $-30^\circ\text{C}$ to $+85^\circ\text{C}$ )	$\Delta P1\text{dB}$	—	0.003	—	dBm/ $^\circ\text{C}$

**Typical Driver Performances** (In Freescale Test Fixture, 50 ohm system)  $V_{DD} = 28\text{ Vdc}$ ,  $I_{DQ1} = 77\text{ mA}$ ,  $I_{DQ2} = 275\text{ mA}$ ,  $P_{out} = 26\text{ dBm Avg.}$ ,  $f = 2700\text{ MHz}$ , WiMAX, OFDM 802.16d, 64 QAM  $3/4$ , 4 Bursts, 10 MHz Channel Bandwidth, Input Signal PAR = 9.5 dB @ 0.01% Probability on CCDF. ACPR measured in 1 MHz Channel Bandwidth @  $\pm 8.5\text{ MHz}$  Offset.

Power Gain	$G_{ps}$	—	27.8	—	dB
Power Added Efficiency	PAE	—	3.2	—	%
Output Peak-to-Average Ratio @ 0.01% Probability on CCDF	PAR	—	9	—	dB
Adjacent Channel Power Ratio	ACPR	—	-56	—	dBc
Input Return Loss	IRL	—	-13	—	dB
Relative Constellation Error @ $P_{out} = 1.25\text{ W Avg.}$ (1)	RCE	—	-40	—	dB

1. RCE =  $20\text{Log}(EVM/100)$



- |    |                                |      |  |
|----|--------------------------------|------|--|
| Z1 | 0.500" x 0.027" Microstrip     | Z9   | 0.040" x 0.061" Microstrip                   |
| Z2 | 0.075" x 0.127" Microstrip     | Z10  | 0.020" x 0.050" Microstrip                   |
| Z3 | 1.640" x 0.027" Microstrip     | Z11  | 0.050" x 0.050" Microstrip                   |
| Z4 | 0.100" x 0.042" Microstrip     | Z12  | 0.050" x 0.027" Microstrip                   |
| Z5 | 0.151" x 0.268" Microstrip     | Z13* | 0.338" x 0.020" Microstrip                   |
| Z6 | 0.025" x 0.268" x 0.056" Taper | Z14  | 1.551" x 0.027" Microstrip                   |
| Z7 | 0.050" x 0.056" Microstrip     | PCB  | Rogers R04350B, 0.0133", $\epsilon_r = 3.48$ |
| Z8 | 0.356" x 0.056" Microstrip     |      | * Line length includes microstrip bends      |

**Figure 3. MW7IC2725NR1(GNR1)(NBR1) Test Circuit Schematic**

**Table 6. MW7IC2725NR1(GNR1)(NBR1) Test Circuit Component Designations and Values**

Part	Description	Part Number	Manufacturer
B1	47 $\Omega$ , 100 MHz Short Ferrite Bead	2743019447	Fair-Rite
C1, C4, C7, C12, C15	6.8 pF Chip Capacitors	ATC600S6R8CT250XT	ATC
C2, C5, C8, C13	10 nF Chip Capacitors	C0603C103J5RAC	Kemet
C3, C6, C9, C14	1 $\mu$ F, 50 V Chip Capacitors	GRM32RR71H105KA01B	Murata
C10	2.4 pF Chip Capacitor	ATC600S2R4BT250XT	ATC
C11	3.3 pF Chip Capacitor	ATC600S3R3BT250XT	ATC
C16, C17	10 $\mu$ F, 50 V Chip Capacitors	GRM55DR61H106KA88B	Murata
R1, R4	12 K $\Omega$ , 1/4 W Chip Resistors	CRCW12061202FKEA	Vishay
R2, R3, R5, R6	1 K $\Omega$ , 1/4 W Chip Resistors	CRCW12061001FKEA	Vishay

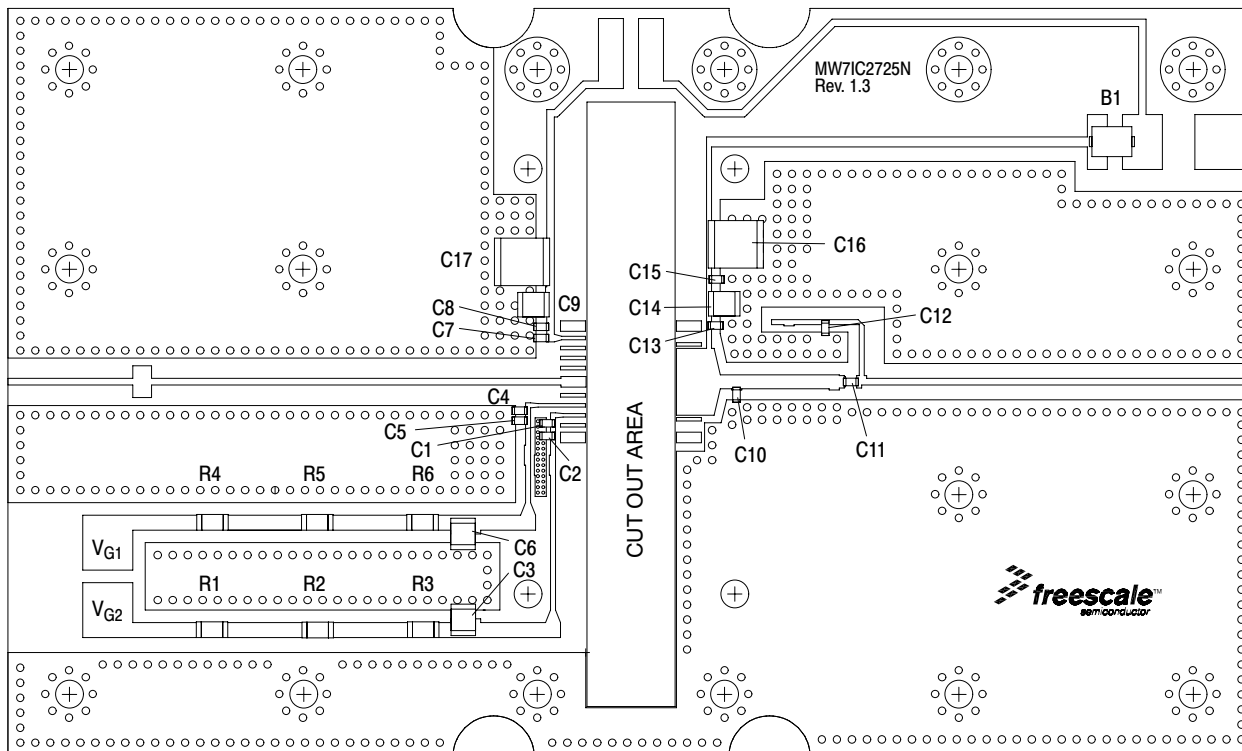


Figure 4. MW7IC2725NR1(GNR1)(NBR1) Test Circuit Component Layout

### TYPICAL CHARACTERISTICS

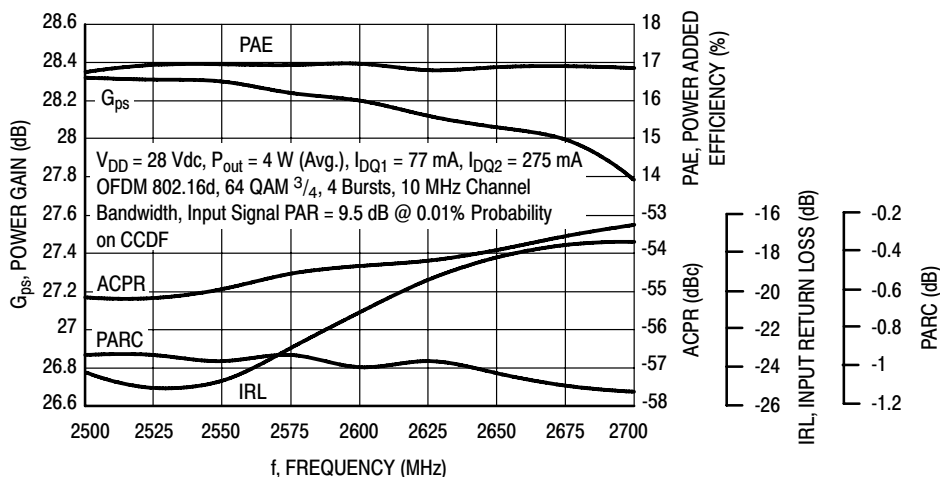


Figure 5. WiMAX Broadband Performance @  $P_{out} = 4 \text{ Watts Avg.}$

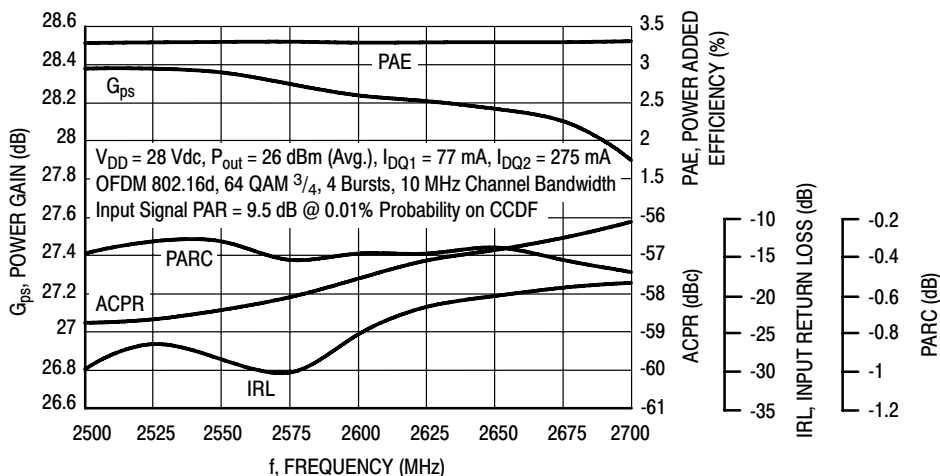


Figure 6. WiMAX Broadband Performance @  $P_{out} = 26 \text{ dBm Avg.}$

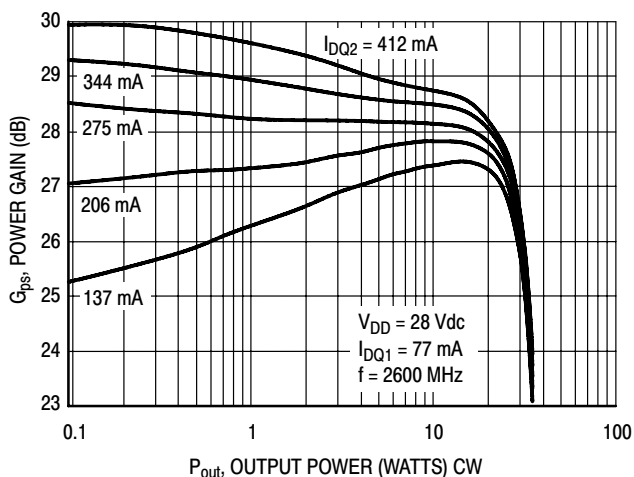


Figure 7. Power Gain versus Output Power @  $I_{DQ1} = 77 \text{ mA}$

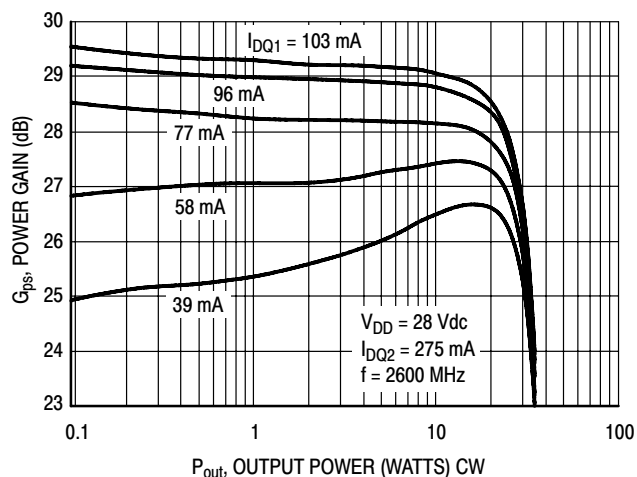
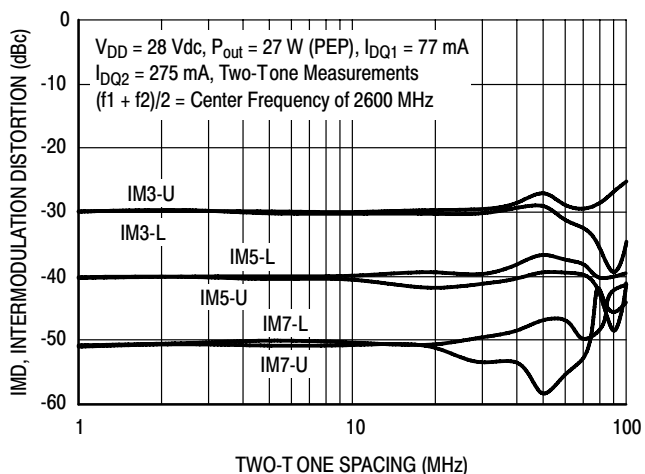
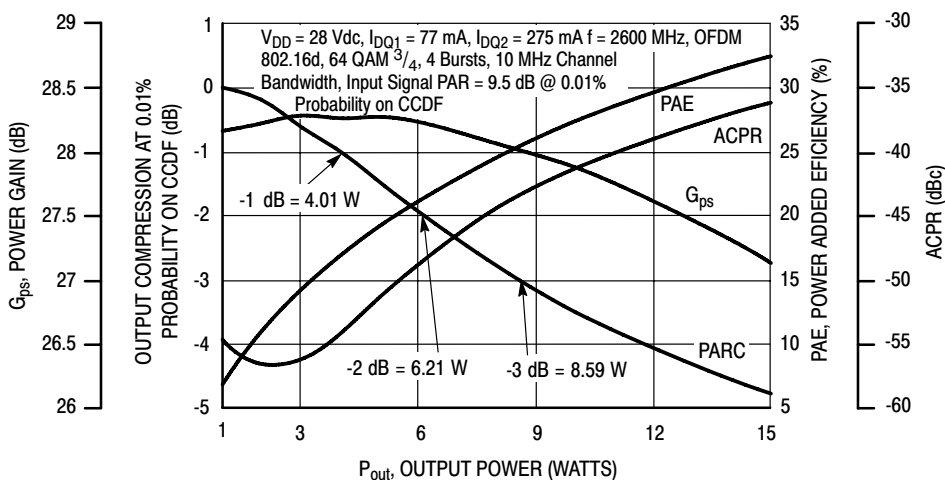


Figure 8. Power Gain versus Output Power @  $I_{DQ2} = 275 \text{ mA}$

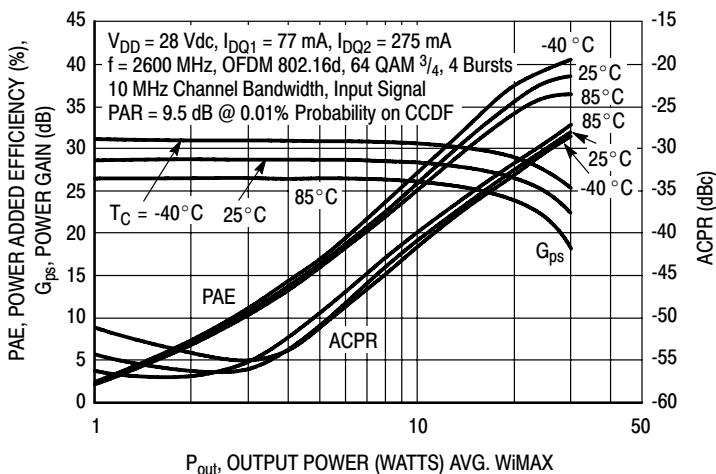
### TYPICAL CHARACTERISTICS



**Figure 9. Intermodulation Distortion Products versus Tone Spacing**

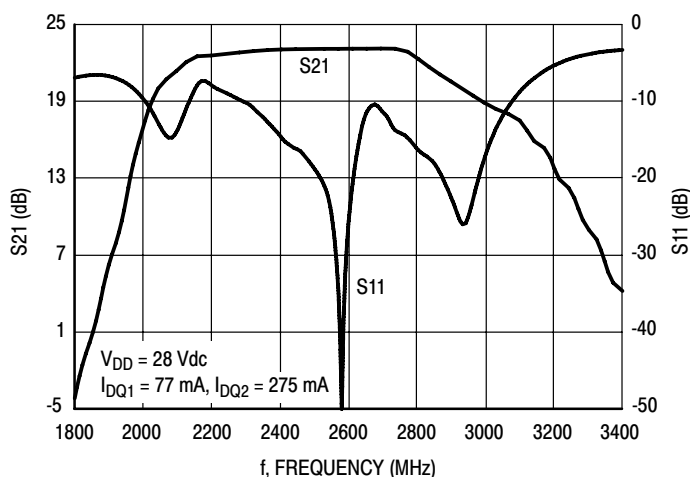


**Figure 10. Output Peak-to-Average Ratio Compression (PARC) versus Output Power**

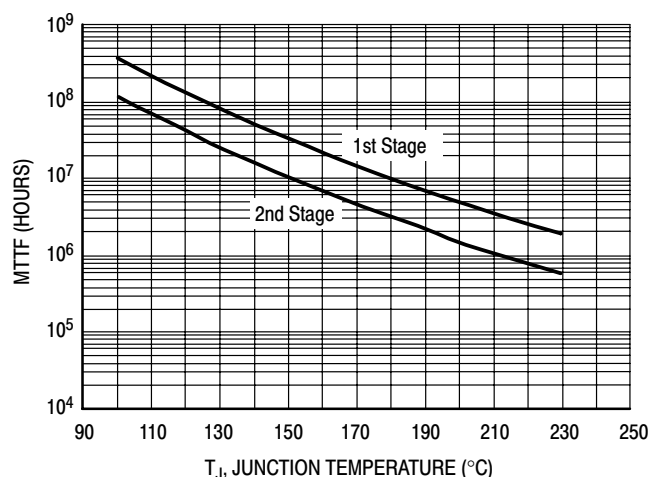


**Figure 11. WiMAX, ACPR, Power Gain and Power Added Efficiency versus Output Power**

### TYPICAL CHARACTERISTICS



**Figure 12. Broadband Frequency Response**

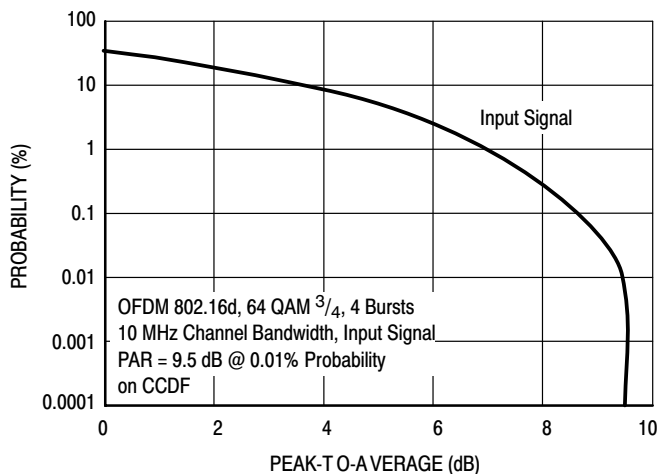


This above graph displays calculated MTTF in hours when the device is operated at  $V_{DD} = 28$  Vdc,  $P_{out} = 4$  W Avg., and  $PAE = 17\%$ .

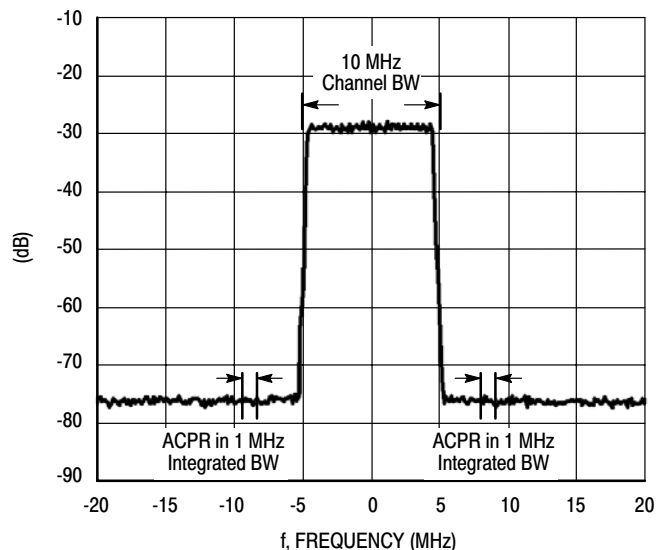
MTTF calculator available at <http://www.freescale.com/rf>. Select Software & Tools/Development Tools/Calculators to access MTTF calculators by product.

**Figure 13. MTTF versus Junction Temperature**

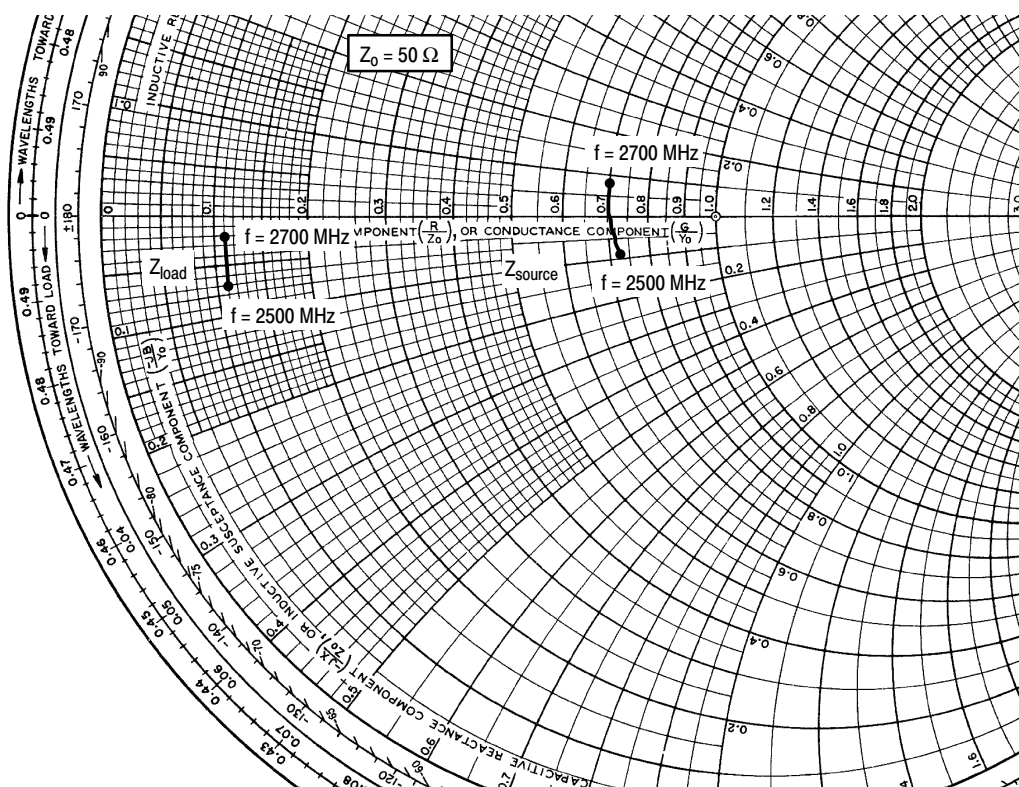
### WIMAX TEST SIGNAL



**Figure 14. OFDM 802.16d Test Signal**



**Figure 15. WiMAX Spectrum Mask Specifications**



$V_{DD} = 28 \text{ Vdc}$ ,  $I_{DQ1} = 77 \text{ mA}$ ,  $I_{DQ2} = 275 \text{ mA}$ ,  $P_{out} = 4 \text{ W Avg.}$

f MHz	$Z_{source}$ $\Omega$	$Z_{load}$ $\Omega$
2500	36.381 - j4.271	5.717 - j3.618
2525	36.041 - j3.328	5.624 - j3.187
2550	35.753 - j2.363	5.578 - j2.770
2575	35.516 - j1.380	5.589 - j2.412
2600	35.333 - j0.381	5.586 - j2.088
2625	35.203 + j0.635	5.579 - j1.807
2650	35.126 + j1.664	5.552 - j1.559
2675	35.104 + j2.707	5.564 - j1.335
2700	35.138 + j3.760	5.568 - j1.164

$Z_{source}$  = Test circuit impedance as measured from gate to ground.

$Z_{load}$  = Test circuit impedance as measured from drain to ground.

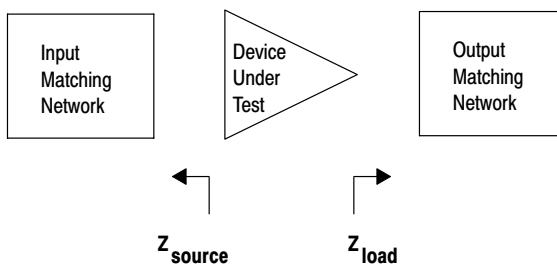


Figure 16. Series Equivalent Source and Load Impedance

**Table 7. Common Source S-Parameters** ( $V_{DD} = 28\text{ V}$ ,  $I_{DQ1} = 77\text{ mA}$ ,  $I_{DQ2} = 275\text{ mA}$ ,  $T_C = 25^\circ\text{C}$ , 50 Ohm System)

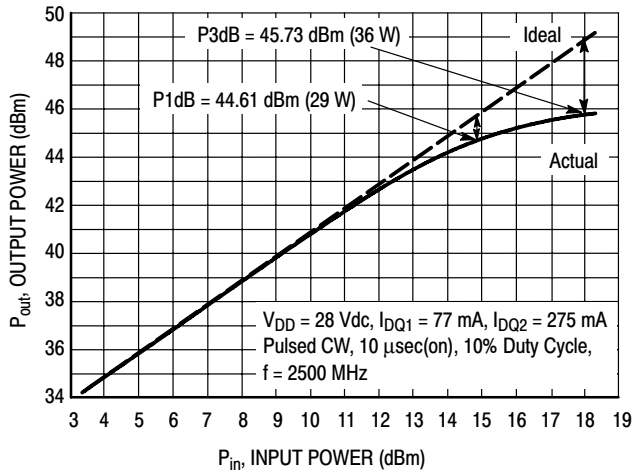
f MHz	S <sub>11</sub>		S <sub>21</sub>		S <sub>12</sub>		S <sub>22</sub>	
	S <sub>11</sub>	∠ φ	S <sub>21</sub>	∠ φ	S <sub>12</sub>	∠ φ	S <sub>22</sub>	∠ φ
1500	0.735	61.0	0.001	-167.6	0.000501	26.6	0.992	167.9
1550	0.729	53.3	0.004	-146.0	0.000361	34.7	0.993	166.3
1600	0.715	46.5	0.014	-146.4	0.000114	109.5	0.991	164.6
1650	0.695	39.8	0.039	-152.5	0.000385	148.4	0.992	162.7
1700	0.665	32.9	0.110	-166.8	0.000773	155.6	0.989	160.5
1750	0.619	25.0	0.299	169.4	0.00134	153.2	0.979	157.8
1800	0.549	15.1	0.708	134.4	0.00198	143.0	0.944	155.2
1850	0.452	2.6	1.335	96.3	0.00250	131.2	0.903	153.9
1900	0.332	-14.4	2.195	62.1	0.00290	121.7	0.879	153.0
1950	0.199	-40.1	3.445	32.7	0.00320	113.8	0.847	151.0
2000	0.089	-91.9	5.724	4.8	0.00345	108.5	0.817	147.7
2050	0.078	167.4	10.041	-26.2	0.00382	107.0	0.749	140.6
2100	0.116	90.3	19.072	-65.1	0.00525	105.3	0.571	125.2
2150	0.170	-13.2	32.642	-126.0	0.00781	77.9	0.054	160.2
2200	0.192	-93.2	31.339	171.3	0.00640	41.0	0.555	-144.4
2250	0.177	-123.0	26.174	130.3	0.00432	24.9	0.726	-160.3
2300	0.163	-132.6	23.605	98.7	0.00294	22.3	0.770	-167.1
2350	0.153	-140.5	22.427	70.0	0.00224	31.0	0.789	-170.1
2400	0.119	-153.6	21.922	41.7	0.00208	42.5	0.800	-171.0
2450	0.059	-165.3	21.172	14.2	0.00216	48.9	0.820	-171.2
2500	0.014	-50.7	20.172	-12.5	0.00227	48.9	0.850	-171.3
2550	0.055	-55.0	19.222	-39.5	0.00213	51.4	0.889	-171.7
2600	0.056	-84.7	17.366	-66.8	0.00209	57.8	0.933	-173.2
2650	0.029	177.4	14.562	-91.5	0.00247	65.6	0.961	-175.8
2700	0.069	103.3	12.199	-111.7	0.00286	62.2	0.968	-178.0
2750	0.122	84.1	10.485	-130.4	0.00308	56.3	0.969	-179.5
2800	0.287	59.8	8.086	-154.4	0.00326	50.9	0.969	179.3
2850	0.184	-5.4	7.102	-152.5	0.00292	39.2	0.966	178.6
2900	0.129	-17.4	6.753	-169.3	0.00256	38.6	0.969	178.0
2950	0.128	-41.0	6.107	175.4	0.00232	38.5	0.970	177.4
3000	0.164	-65.7	5.445	160.8	0.00213	39.9	0.972	176.9
3050	0.223	-86.2	4.867	146.7	0.00196	42.0	0.972	176.4
3100	0.297	-100.4	4.363	133.2	0.00183	46.0	0.973	176.0
3150	0.374	-110.4	3.918	120.0	0.00176	51.4	0.974	175.5
3200	0.447	-118.0	3.534	107.2	0.00181	56.5	0.974	174.9
3250	0.515	-123.4	3.198	95.3	0.00191	60.9	0.975	174.3
3300	0.563	-128.0	2.951	83.3	0.00211	58.8	0.975	173.7
3350	0.619	-131.8	2.761	71.2	0.00206	63.0	0.976	173.0
3400	0.651	-136.0	2.581	58.8	0.00218	64.8	0.975	172.3
3450	0.671	-140.1	2.418	46.0	0.00237	68.3	0.975	171.6

(continued)

**Table 7. Common Source S-Parameters** ( $V_{DD} = 28\text{ V}$ ,  $I_{DQ1} = 77\text{ mA}$ ,  $I_{DQ2} = 275\text{ mA}$ ,  $T_C = 25^\circ\text{C}$ , 50 Ohm System) (continued)

f MHz	S <sub>11</sub>		S <sub>21</sub>		S <sub>12</sub>		S <sub>22</sub>	
	S <sub>11</sub>	∠ φ	S <sub>21</sub>	∠ φ	S <sub>12</sub>	∠ φ	S <sub>22</sub>	∠ φ
3500	0.679	-144.4	2.257	32.6	0.00265	68.5	0.974	171.0
3550	0.677	-147.9	2.054	19.2	0.00280	65.0	0.976	170.5
3600	0.661	-153.5	1.851	5.0	0.00281	67.1	0.976	170.0
3650	0.696	-153.8	1.644	-5.8	0.00328	69.3	0.976	169.6
3700	0.721	-161.3	1.453	-19.4	0.00350	65.8	0.977	169.4
3750	0.737	-168.1	1.243	-32.1	0.00357	64.5	0.978	169.2
3800	0.753	-174.7	1.042	-43.7	0.00374	64.5	0.979	169.2
3850	0.771	179.2	0.859	-54.3	0.00401	62.5	0.980	169.2
3900	0.788	174.4	0.708	-62.8	0.00407	58.4	0.980	169.3
3950	0.812	169.8	0.583	-71.5	0.00416	57.7	0.981	169.3
4000	0.829	166.0	0.477	-79.0	0.00427	55.8	0.982	169.3

## ALTERNATIVE PEAK TUNE LOAD PULL CHARACTERISTICS

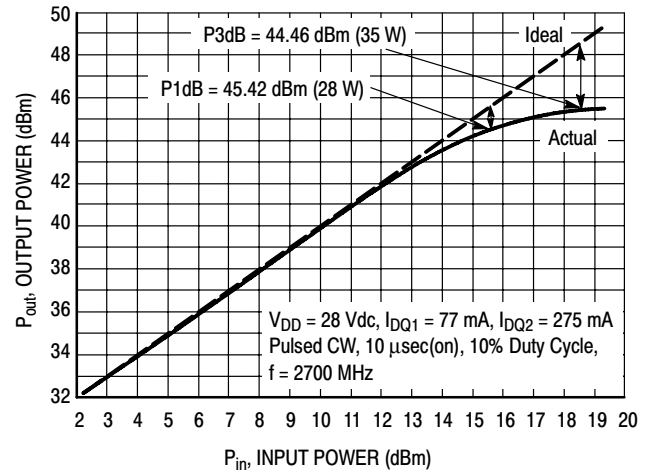


NOTE: Load Pull Test Fixture Tuned for Peak P1dB Output Power @ 28 V

Test Impedances per Compression Level

	$Z_{source}$ $\Omega$	$Z_{load}$ $\Omega$
P1dB	42.7 + j11.6	4.86 - j1.63

**Figure 17. Pulsed CW Output Power versus Input Power @ 28 V @ 2500 MHz**



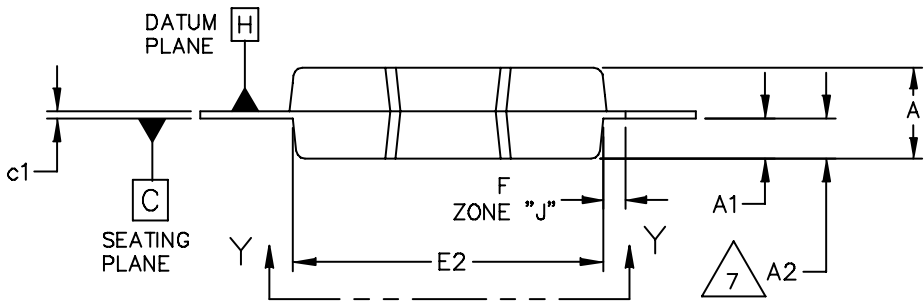
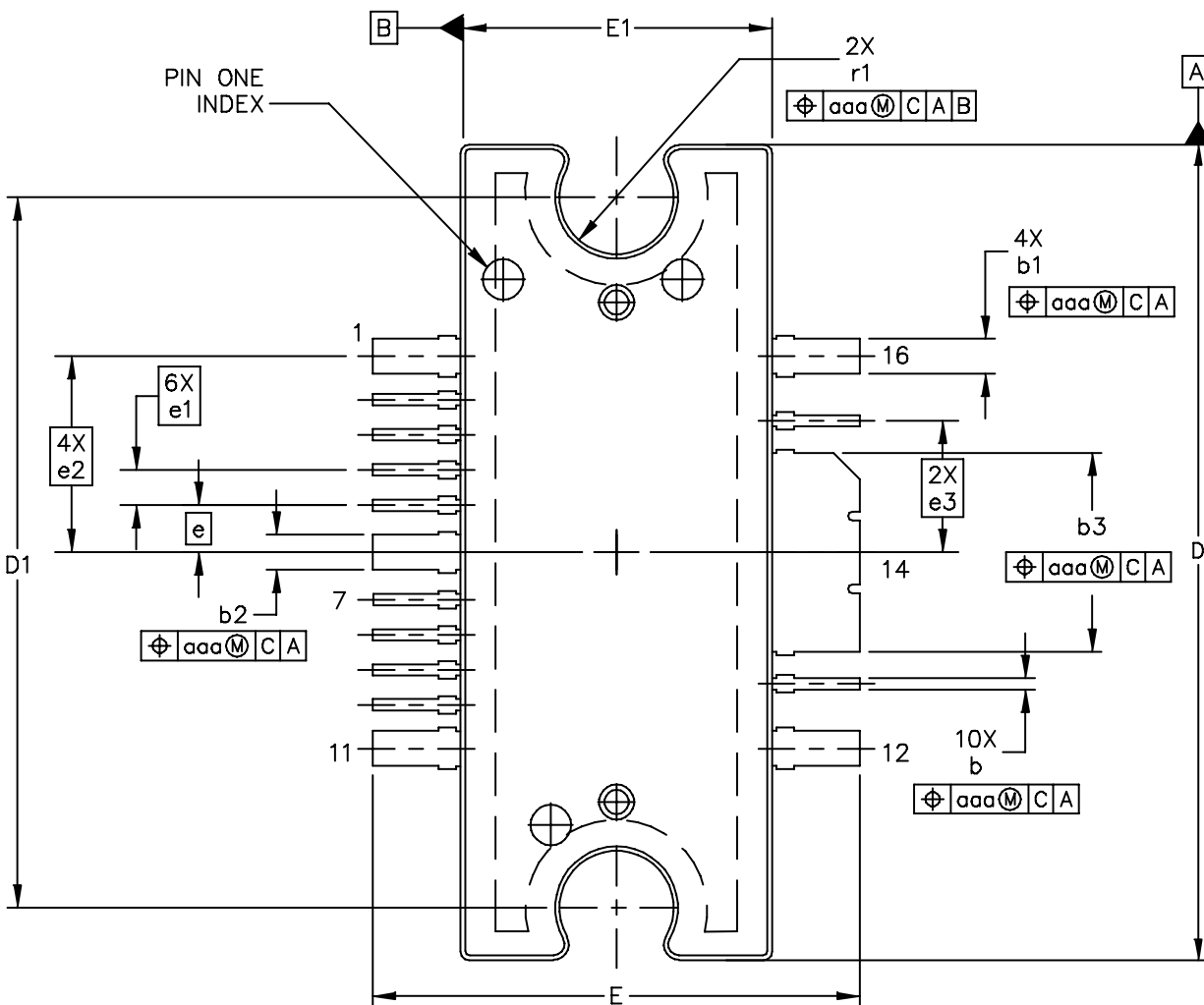
NOTE: Load Pull Test Fixture Tuned for Peak P1dB Output Power @ 28 V

Test Impedances per Compression Level

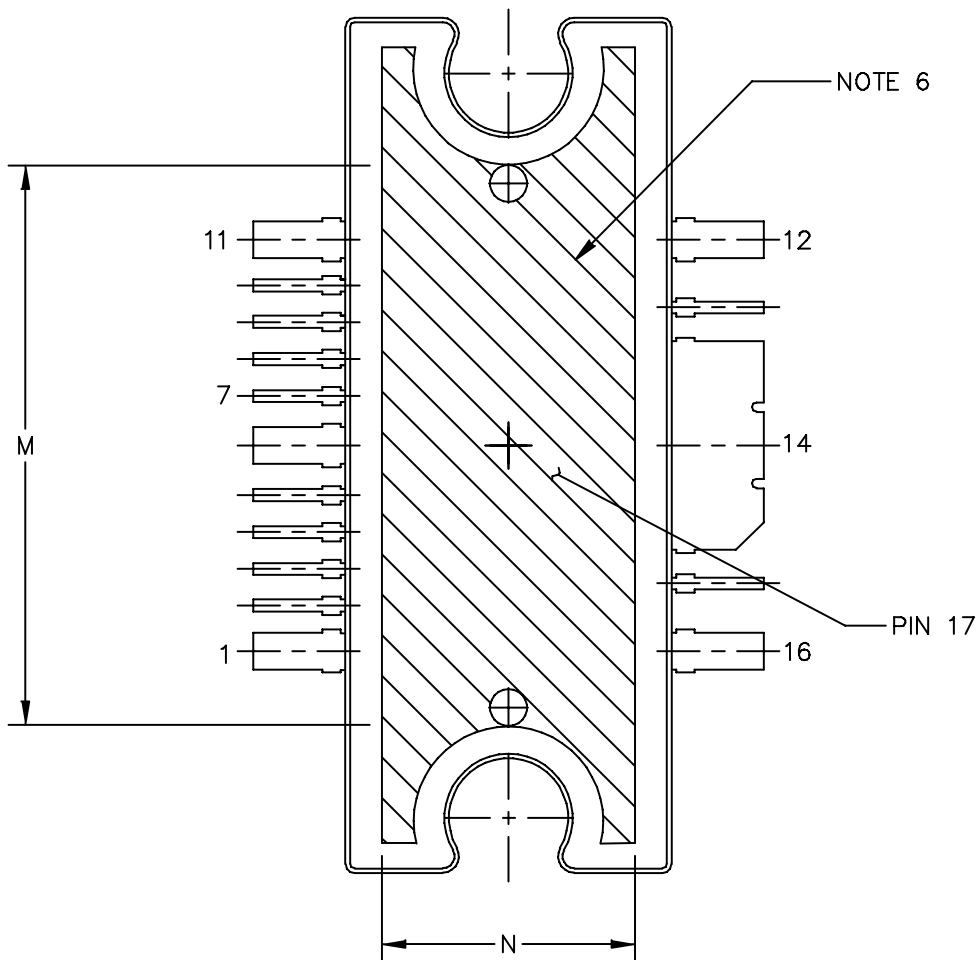
	$Z_{source}$ $\Omega$	$Z_{load}$ $\Omega$
P1dB	39.5 - j8.7	3.53 - j1.66

**Figure 18. Pulsed CW Output Power versus Input Power @ 28 V @ 2700 MHz**

**PACKAGE DIMENSIONS**



© FREESCALE SEMICONDUCTOR, INC. ALL RIGHTS RESERVED.		MECHANICAL OUTLINE	PRINT VERSION NOT TO SCALE
TITLE: TO-272 WIDE BODY MULTI-LEAD	DOCUMENT NO: 98ARH99164A		REV: M
	CASE NUMBER: 1329-09		23 AUG 2007
	STANDARD: NON-JEDEC		



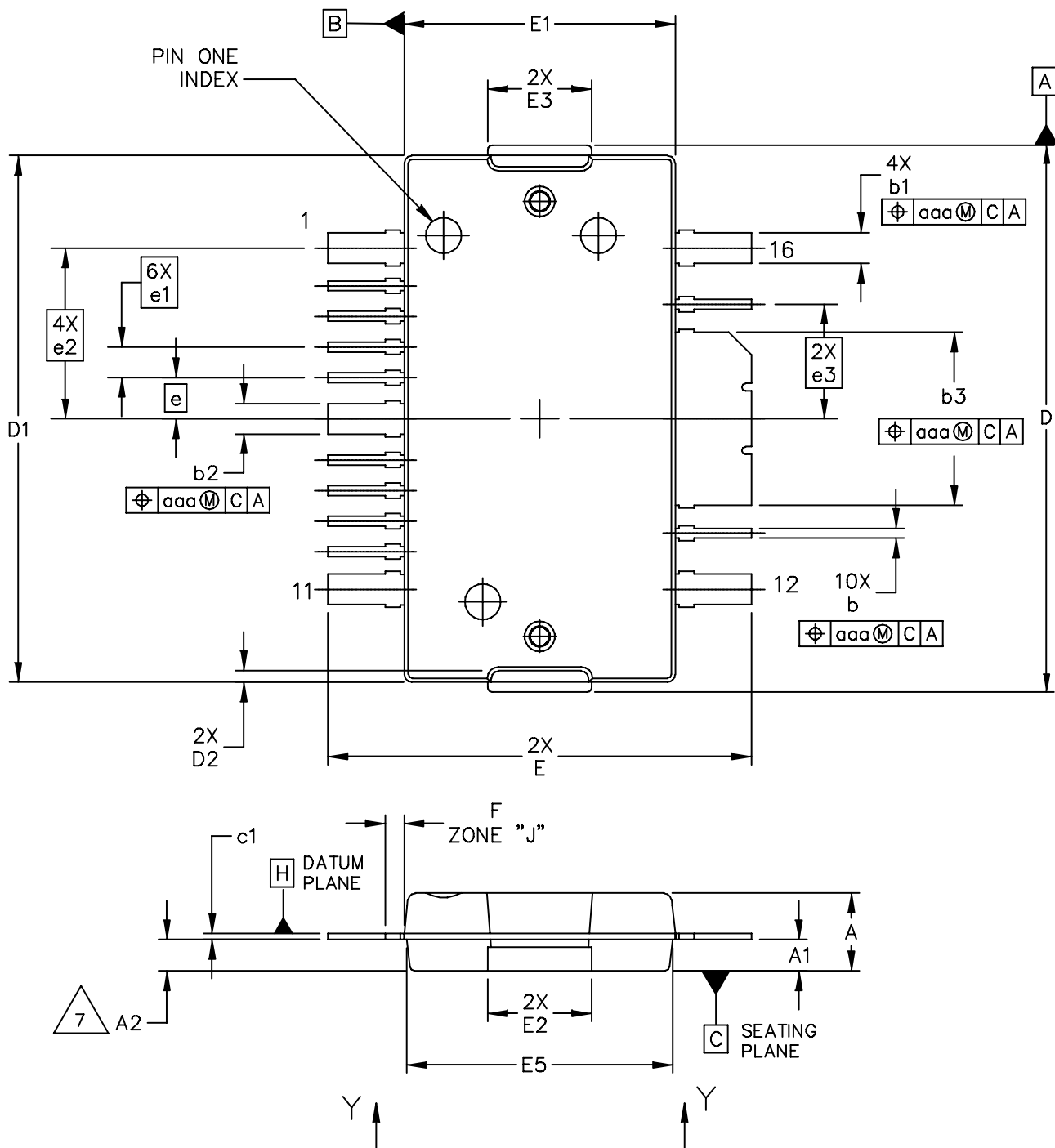
VIEW Y-Y

© FREESCALE SEMICONDUCTOR, INC. ALL RIGHTS RESERVED.	MECHANICAL OUTLINE	PRINT VERSION NOT TO SCALE	
TITLE: TO-272 WIDE BODY MULTI-LEAD	DOCUMENT NO: 98ARH99164A	REV: M	
	CASE NUMBER: 1329-09	23 AUG 2007	
	STANDARD: NON-JEDEC		

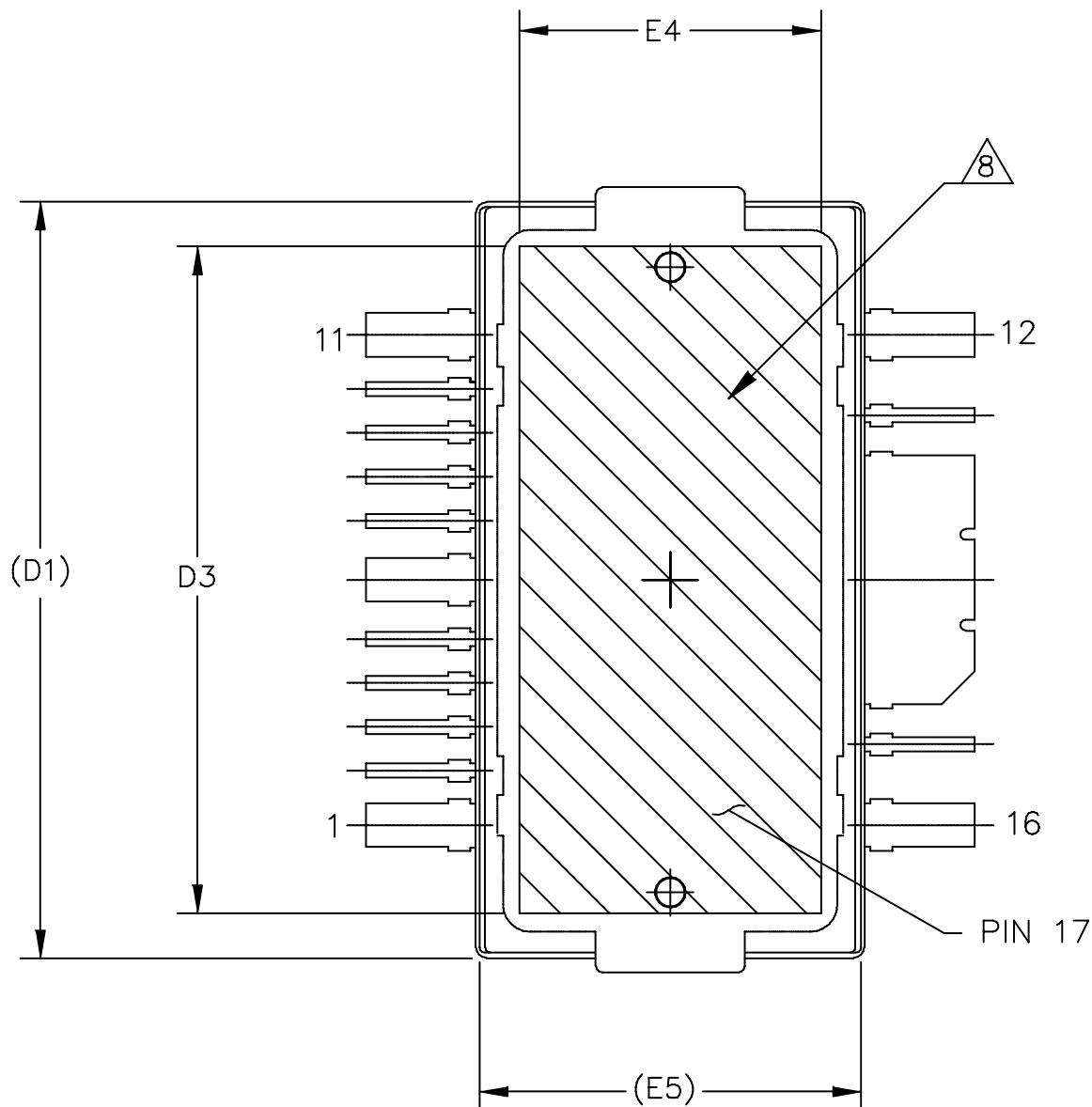
NOTES:

1. CONTROLLING DIMENSION: INCH
2. INTERPRET DIMENSIONS AND TOLERANCES PER ASME Y14.5M-1994.
3. DATUM PLANE -H- IS LOCATED AT THE TOP OF LEAD AND IS COINCIDENT WITH THE LEAD WHERE THE LEAD EXITS THE PLASTIC BODY AT THE TOP OF THE PARTING LINE.
4. DIMENSIONS "D" AND "E1" DO NOT INCLUDE MOLD PROTRUSION. ALLOWABLE PROTRUSION IS .006 (0.15) PER SIDE. DIMENSIONS "D" AND "E1" DO INCLUDE MOLD MISMATCH AND ARE DETERMINED AT DATUM PLANE -H-.
5. DIMENSIONS "b", "b1", "b2" AND "b3" DO NOT INCLUDE DAMBAR PROTRUSION. ALLOWABLE DAMBAR PROTRUSION SHALL BE .005 (0.13) TOTAL IN EXCESS OF THE "b", "b1", "b2" AND "b3" DIMENSIONS AT MAXIMUM MATERIAL CONDITION.
6. HATCHING REPRESENTS THE EXPOSED AREA OF THE HEAT SLUG. HATCHED AREA SHOWN IS ON THE SAME PLANE.
7. DIM A2 APPLIES WITHIN ZONE "J" ONLY.

DIM	INCH		MILLIMETER		DIM	INCH		MILLIMETER	
	MIN	MAX	MIN	MAX		MIN	MAX	MIN	MAX
A	.100	.104	2.54	2.64	b	.011	.017	0.28	0.43
A1	.038	.044	0.96	1.12	b1	.037	.043	0.94	1.09
A2	.040	.042	1.02	1.07	b2	.037	.043	0.94	1.09
D	.928	.932	23.57	23.67	b3	.225	.231	5.72	5.87
D1	.810 BSC		20.57 BSC		c1	.007	.011	.18	.28
E	.551	.559	14.00	14.20	e	.054 BSC		1.37 BSC	
E1	.353	.357	8.97	9.07	e1	.040 BSC		1.02 BSC	
E2	.346	.350	8.79	8.89	e2	.224 BSC		5.69 BSC	
F	.025 BSC		0.64 BSC		e3	.150 BSC		3.81 BSC	
M	.600	----	15.24	----	r1	.063	.068	1.6	1.73
N	.270	----	6.86	----	aaa	.004		.10	
© FREESCALE SEMICONDUCTOR, INC. ALL RIGHTS RESERVED.			MECHANICAL OUTLINE			PRINT VERSION NOT TO SCALE			
TITLE: TO-272 WIDE BODY MULTI-LEAD					DOCUMENT NO: 98ARH99164A			REV: M	
					CASE NUMBER: 1329-09			23 AUG 2007	
					STANDARD: NON-JEDEC				



© FREESCALE SEMICONDUCTOR, INC. ALL RIGHTS RESERVED.	MECHANICAL OUTLINE	PRINT VERSION NOT TO SCALE
TITLE: TO-270 WIDE BODY 16 LEAD	DOCUMENT NO: 98ASA10754D	REV: A
	CASE NUMBER: 1886-01	31 AUG 2007
	STANDARD: NON-JEDEC	



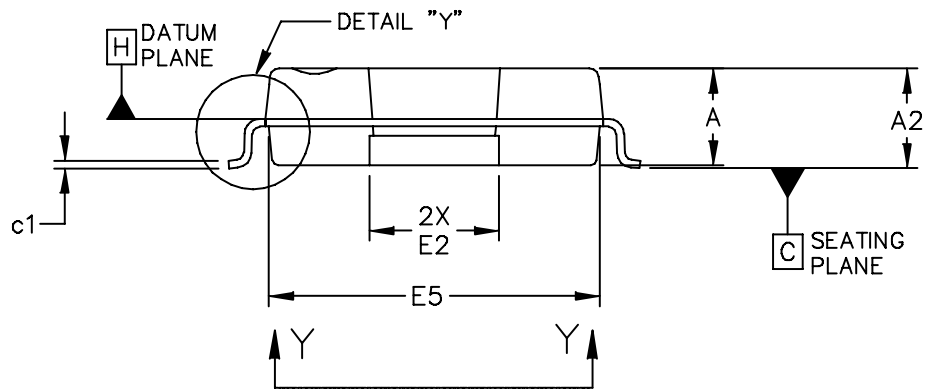
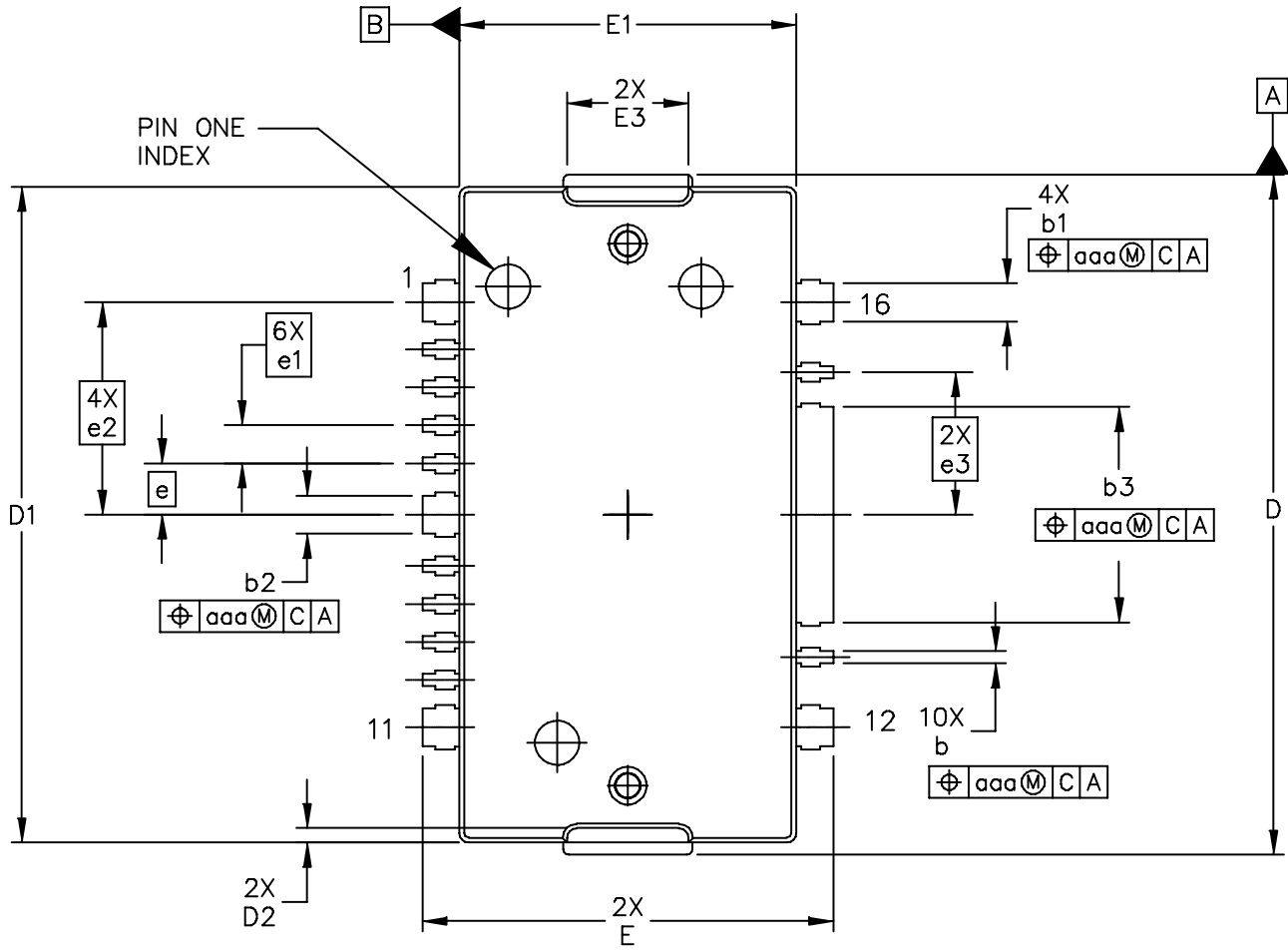
VIEW Y-Y

© FREESCALE SEMICONDUCTOR, INC. ALL RIGHTS RESERVED.	MECHANICAL OUTLINE	PRINT VERSION NOT TO SCALE	
TITLE: TO-270 WIDE BODY 16 LEAD	DOCUMENT NO: 98ASA10754D	REV: A	
	CASE NUMBER: 1886-01	31 AUG 2007	
	STANDARD: NON-JEDEC		

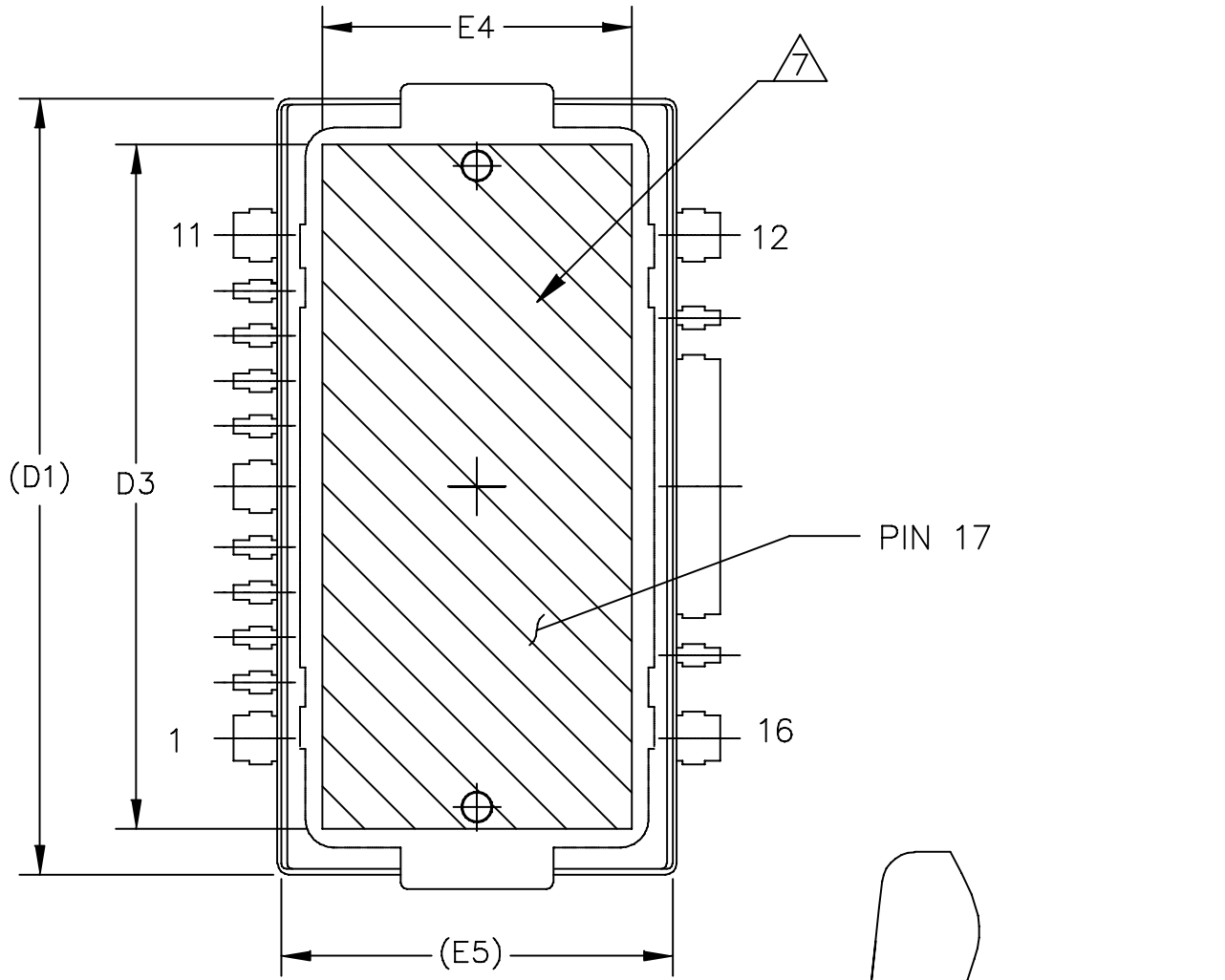
NOTES:

1. CONTROLLING DIMENSION: INCH
2. INTERPRET DIMENSIONS AND TOLERANCES PER ASME Y14.5M-1994.
3. DATUM PLANE -H- IS LOCATED AT THE TOP OF LEAD AND IS COINCIDENT WITH THE LEAD WHERE THE LEAD EXITS THE PLASTIC BODY AT THE TOP OF THE PARTING LINE.
4. DIMENSIONS "D" AND "E1" DO NOT INCLUDE MOLD PROTRUSION. ALLOWABLE PROTRUSION IS .006 (0.15) PER SIDE. DIMENSIONS "D" AND "E1" DO INCLUDE MOLD MISMATCH AND ARE DETERMINED AT DATUM PLANE -H-.
5. DIMENSIONS "b", "b1", "b2" AND "b3" DO NOT INCLUDE DAMBAR PROTRUSION. ALLOWABLE DAMBAR PROTRUSION SHALL BE .005 (0.13) TOTAL IN EXCESS OF THE "b", "b1", "b2" AND "b3" DIMENSIONS AT MAXIMUM MATERIAL CONDITION.
6. DATUM -A- AND -B- TO BE DETERMINED AT DATUM PLANE -H-.
7. DIMENSION A2 APPLIES WITHIN ZONE "J" ONLY.
8. HATCHING REPRESENTS THE EXPOSED AREA OF THE HEAT SLUG. HATCHED AREA SHOWN IS ON THE SAME PLANE.

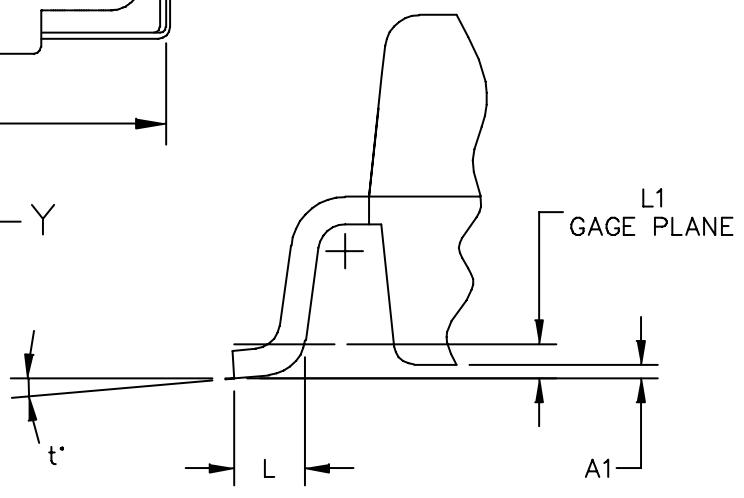
DIM	INCH		MILLIMETER		DIM	INCH		MILLIMETER	
	MIN	MAX	MIN	MAX		MIN	MAX	MIN	MAX
A	.100	.104	2.54	2.64	F	.025 BSC		0.64 BSC	
A1	.039	.043	0.99	1.09	b	.011	.017	0.28	0.43
A2	.040	.042	1.02	1.07	b1	.037	.043	0.94	1.09
D	.712	.720	18.08	18.29	b2	.037	.043	0.94	1.09
D1	.688	.692	17.48	17.58	b3	.225	.231	5.72	5.87
D2	.011	.019	0.28	0.48	c1	.007	.011	.18	.28
D3	.600	---	15.24	---	e	.054 BSC		1.37 BSC	
E	.551	.559	14	14.2	e1	.040 BSC		1.02 BSC	
E1	.353	.357	8.97	9.07	e2	.224 BSC		5.69 BSC	
E2	.132	.140	3.35	3.56	e3	.150 BSC		3.81 BSC	
E3	.124	.132	3.15	3.35	aaa	.004		.10	
E4	.270	---	6.86	---					
E5	.346	.350	8.79	8.89					
© FREESCALE SEMICONDUCTOR, INC. ALL RIGHTS RESERVED.			MECHANICAL OUTLINE			PRINT VERSION NOT TO SCALE			
TITLE: TO-270 WIDE BODY 16 LEAD					DOCUMENT NO: 98ASA10754D			REV: A	
					CASE NUMBER: 1886-01			31 AUG 2007	
					STANDARD: NON-JEDEC				



© FREESCALE SEMICONDUCTOR, INC. ALL RIGHTS RESERVED.		MECHANICAL OUTLINE		PRINT VERSION NOT TO SCALE	
TITLE: TO-270 WIDE BODY 16 LEAD, GULL WING	DOCUMENT NO: 98ASA10755D		REV: A		
	CASE NUMBER: 1887-01		31 AUG 2007		
	STANDARD: NON-JEDEC				



VIEW Y-Y



DETAIL "Y"

© FREESCALE SEMICONDUCTOR, INC. ALL RIGHTS RESERVED.		MECHANICAL OUTLINE		PRINT VERSION NOT TO SCALE	
TITLE: TO-270 WIDE BODY 16 LEAD, GULL WING	DOCUMENT NO: 98ASA10755D		REV: A		
	CASE NUMBER: 1887-01		31 AUG 2007		
	STANDARD: NON-JEDEC				

NOTES:

1. CONTROLLING DIMENSION: INCH
2. INTERPRET DIMENSIONS AND TOLERANCES PER ASME Y14.5M-1994.
3. DATUM PLANE -H- IS LOCATED AT THE TOP OF LEAD AND IS COINCIDENT WITH THE LEAD WHERE THE LEAD EXITS THE PLASTIC BODY AT THE TOP OF THE PARTING LINE.
4. DIMENSIONS "D" AND "E1" DO NOT INCLUDE MOLD PROTRUSION. ALLOWABLE PROTRUSION IS .006 (0.15) PER SIDE. DIMENSIONS "D" AND "E1" DO INCLUDE MOLD MISMATCH AND ARE DETERMINED AT DATUM PLANE -H-.
5. DIMENSIONS "b", "b1", "b2" AND "b3" DO NOT INCLUDE DAMBAR PROTRUSION. ALLOWABLE DAMBAR PROTRUSION SHALL BE .005 (0.13) TOTAL IN EXCESS OF THE "b", "b1", "b2" AND "b3" DIMENSIONS AT MAXIMUM MATERIAL CONDITION.
6. DATUM -A- AND -B- TO BE DETERMINED AT DATUM PLANE -H-.
7. HATCHING REPRESENTS EXPOSED AREA OF THE HEAT SLUG. HATCHED AREA SHOWN IS ON THE SAME PLANE.

DIM	INCH		MILLIMETER		DIM	INCH		MILLIMETER	
	MIN	MAX	MIN	MAX		MIN	MAX	MIN	MAX
A	.100	.104	2.54	2.64	L	.018	.024	0.46	0.61
A1	.001	.004	0.02	0.10	L1	.010 BSC		0.25 BSC	
A2	.099	.110	2.51	2.79	b	.011	.017	0.28	0.43
D	.712	.720	18.08	18.29	b1	.037	.043	0.94	1.09
D1	.688	.692	17.48	17.58	b2	.037	.043	0.94	1.09
D2	.011	.019	0.28	0.48	b3	.225	.231	5.72	5.87
D3	.600	---	15.24	---	c1	.007	.011	0.18	0.28
E	.429	.437	10.9	11.1	e	.054 BSC		1.37 BSC	
E1	.353	.357	8.97	9.07	e1	.040 BSC		1.02 BSC	
E2	.132	.140	3.35	3.56	e2	.224 BSC		5.69 BSC	
E3	.124	.132	3.15	3.35	e3	.150 BSC		3.81 BSC	
E4	.270	---	6.86	---	t	2'	8'	2'	8'
E5	.346	.350	8.79	8.89	aaa	.004		0.10	

© FREESCALE SEMICONDUCTOR, INC. ALL RIGHTS RESERVED.		MECHANICAL OUTLINE		PRINT VERSION NOT TO SCALE	
TITLE: TO-270 WIDE BODY 16 LEAD, GULL WING			DOCUMENT NO: 98ASA10755D		REV: A
			CASE NUMBER: 1887-01		31 AUG 2007
			STANDARD: NON-JEDEC		

Refer to the following documents to aid your design process.

**Application Notes**

- AN1907: Solder Reflow Attach Method for High Power RF Devices in Plastic Packages
- AN1955: Thermal Measurement Methodology of RF Power Amplifiers
- AN1977: Quiescent Current Thermal Tracking Circuit in the RF Integrated Circuit Family
- AN1987: Quiescent Current Control for the RF Integrated Circuit Device Family
- AN3263: Bolt Down Mounting Method for High Power RF Transistors and RFICs in Over-Molded Plastic Packages
- AN3789: Clamping of High Power RF Transistors and RFICs in Over-Molded Plastic Packages

**Engineering Bulletins**

- EB212: Using Data Sheet Impedances for RF LDMOS Devices

**Software**

- Electromigration MTTF Calculator
- RF High Power Model

For Software and Tools, do a Part Number search at <http://www.freescale.com>, and select the “Part Number” link. Go to the Software & Tools tab on the part’s Product Summary page to download the respective tool.

**REVISION HISTORY**

The following table summarizes revisions to this document.

Revision	Date	Description
0	June 2008	<ul style="list-style-type: none"> <li>• Initial Release of Data Sheet</li> </ul>
1	July 2008	<ul style="list-style-type: none"> <li>• Added MW71C2725NBR1 device and corresponding case outline information to data sheet.</li> </ul>
2	Oct. 2008	<ul style="list-style-type: none"> <li>• Added Fig. 13, MTTF versus Junction Temperature, p. 9</li> </ul>
3	Jan. 2010	<ul style="list-style-type: none"> <li>• Modified VSWR rating to show the 3 dB overdrive capability, p. 1</li> <li>• Maximum Ratings table: Added Case Operating Temperature and set limit to 150°C. Corrected maximum input power level to the tested value from 20 dBm to 22 dBm, p. 2</li> <li>• Added AN3789, Clamping of High Power RF Transistors and RFICs in Over-Molded Plastic Packages to Product Documentation, Application Notes, p. 23</li> </ul>

## **How to Reach Us:**

### **Home Page:**

[www.freescale.com](http://www.freescale.com)

### **Web Support:**

<http://www.freescale.com/support>

### **USA/Europe or Locations Not Listed:**

Freescale Semiconductor, Inc.  
 Technical Information Center, EL516  
 2100 East Elliot Road  
 Tempe, Arizona 85284  
 1-800-521-6274 or +1-480-768-2130  
[www.freescale.com/support](http://www.freescale.com/support)

### **Europe, Middle East, and Africa:**

Freescale Halbleiter Deutschland GmbH  
 Technical Information Center  
 Schatzbogen 7  
 81829 Muenchen, Germany  
 +44 1296 380 456 (English)  
 +46 8 52200080 (English)  
 +49 89 92103 559 (German)  
 +33 1 69 35 48 48 (French)  
[www.freescale.com/support](http://www.freescale.com/support)

### **Japan:**

Freescale Semiconductor Japan Ltd.  
 Headquarters  
 ARCO Tower 15F  
 1-8-1, Shimo-Meguro, Meguro-ku,  
 Tokyo 153-0064  
 Japan  
 0120 191014 or +81 3 5437 9125  
[support.japan@freescale.com](mailto:support.japan@freescale.com)

### **Asia/Pacific:**

Freescale Semiconductor China Ltd.  
 Exchange Building 23F  
 No. 118 Jianguo Road  
 Chaoyang District  
 Beijing 100022  
 China  
 +86 10 5879 8000  
[support.asia@freescale.com](mailto:support.asia@freescale.com)

### **For Literature Requests Only:**

Freescale Semiconductor Literature Distribution Center  
 1-800-441-2447 or +1-303-675-2140  
 Fax: +1-303-675-2150  
[LDCForFreescaleSemiconductor@hibbertgroup.com](mailto:LDCForFreescaleSemiconductor@hibbertgroup.com)

Information in this document is provided solely to enable system and software implementers to use Freescale Semiconductor products. There are no express or implied copyright licenses granted hereunder to design or fabricate any integrated circuits or integrated circuits based on the information in this document.

Freescale Semiconductor reserves the right to make changes without further notice to any products herein. Freescale Semiconductor makes no warranty, representation or guarantee regarding the suitability of its products for any particular purpose, nor does Freescale Semiconductor assume any liability arising out of the application or use of any product or circuit, and specifically disclaims any and all liability, including without limitation consequential or incidental damages. "Typical" parameters that may be provided in Freescale Semiconductor data sheets and/or specifications can and do vary in different applications and actual performance may vary over time. All operating parameters, including "Typicals", must be validated for each customer application by customer's technical experts. Freescale Semiconductor does not convey any license under its patent rights nor the rights of others. Freescale Semiconductor products are not designed, intended, or authorized for use as components in systems intended for surgical implant into the body, or other applications intended to support or sustain life, or for any other application in which the failure of the Freescale Semiconductor product could create a situation where personal injury or death may occur. Should Buyer purchase or use Freescale Semiconductor products for any such unintended or unauthorized application, Buyer shall indemnify and hold Freescale Semiconductor and its officers, employees, subsidiaries, affiliates, and distributors harmless against all claims, costs, damages, and expenses, and reasonable attorney fees arising out of, directly or indirectly, any claim of personal injury or death associated with such unintended or unauthorized use, even if such claim alleges that Freescale Semiconductor was negligent regarding the design or manufacture of the part.

Freescale™ and the Freescale logo are trademarks of Freescale Semiconductor, Inc. All other product or service names are the property of their respective owners.

© Freescale Semiconductor, Inc. 2008, 2010. All rights reserved.

## Looking for pricing, stock, or lifecycle information?

Click below to explore more details on WIN SOURCE:

- ⊖ [View MW71C2725NR1 on WIN SOURCE](#)
- ⊖ [Freescale Semiconductor - NXP Information](#)

## Optimize Your Supply Chain with WIN SOURCE Solutions

- ✓ Global Sourcing Solution
- ✓ Obsolete Management
- ✓ Cost Control Management
- ✓ Shortage Management
- ✓ Alternative Solution
- ✓ Excess Inventory Management