



**THE DATASHEET OF
MT89L86ANR**



Features

September 2011

- 3.3 volt supply
- 5 V tolerant inputs and TTL compatible outputs
- 256 x 256 or 512 x 256 switching configurations
- 8-bit or 4-bit channel switching capability
- Guarantees frame integrity for wideband channels
- Automatic identification of ST-BUS/GCI interfaces
- Accepts serial streams with data rates of 2.048, 4.096 or 8.192 Mb/s
- Rate conversion from 2.048 Mb/s to 4.096 or 8.192 Mb/s and vice-versa
- Programmable frame offset on inputs
- Per-channel three-state control
- Per-channel message mode
- Control interface compatible to Intel/Motorola CPUs
- Low power consumption

Applications

- Medium size mixed voice and data switching/processing matrices
- Hyperchannel switching (e.g., ISDN H0)
- MVIP™ interface functions

Ordering Information

MT89L86AN1	48 Pin SSOP*	Tubes
MT89L86ANR1	48 Pin SSOP*	Tape & Reel
MT89L86AP1	44 Pin PLCC*	Tubes
MT89L86APR1	44 Pin PLCC*	Tape & Reel

*Pb Free Matte Tin

-40°C to +85°C

- Serial bus control and monitoring
- Centralized voice processing systems
- Voice/Data multiplexer
- ADPCM 32 kbit/s channel switching

Description

The 3.3 V Multiple Rate Digital Switch (MT89L86) is pin compatible with Zarlink's 5 V MT8986 and retains all of its functionality. This 3.3 V device is designed to provide simultaneous non-blocking connections for up to 256 64 kb/s channels or blocking connections for up to 512 64 kb/s channels. The serial inputs and outputs may have 32 to 128 64 kb/s channels per frame with data rates ranging from 2048 up to 8192 kb/s. It also provides per-channel selection between variable and constant throughput delays allowing voice and grouped data channels to be switched without corrupting the data sequence integrity.

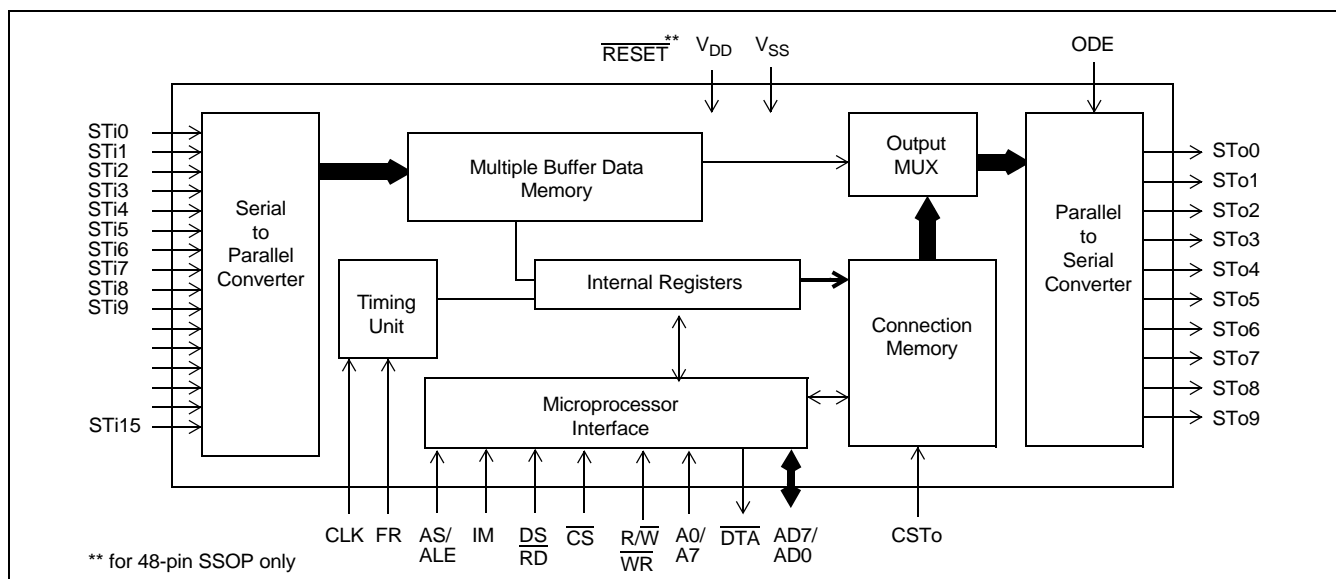
Figure 1 - Functional Block Diagram

Change Summary

Changes from the January 2006 issue to the September 2011 issue.

Page	Item	Change
1	Ordering Information	Removed leaded packages as per PCN notice.

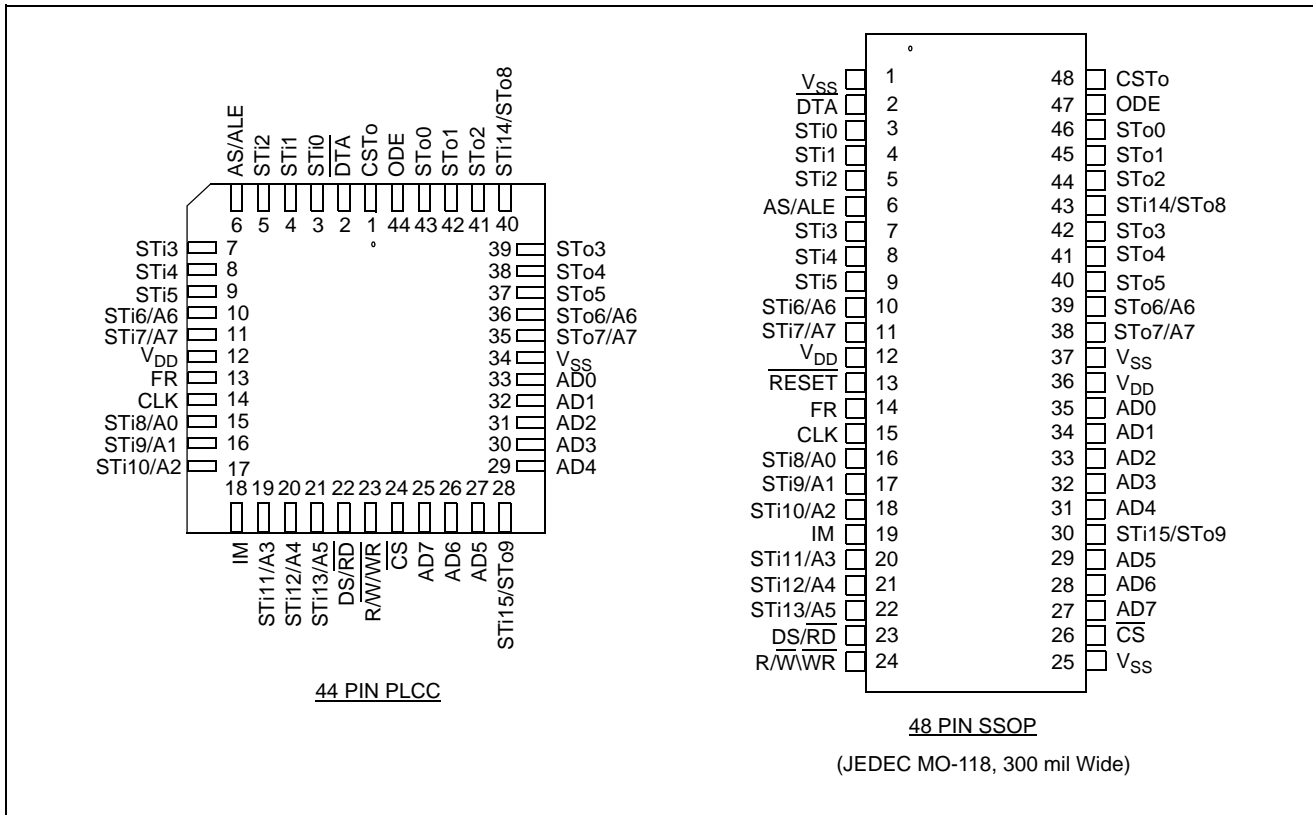

Figure 2 - Pin Connections

Pin Description

Pin #		Name	Description
44 PLCC	48 SSOP		
2	2	\overline{DTA}	Data Acknowledgment (Open Drain Output). This active low output indicates that a data bus transfer is complete. A pull-up resistor is required at this output.
3-5 7-9	3-5 7-9	STi0-5	ST-BUS Inputs 0 to 5 (5 V tolerant Inputs). Serial data input streams. These streams may have data rates of 2.048, 4.096 or 8.192 Mbit/s with 32, 64 or 128 channels, respectively.
10	10	STi6/A6	ST-BUS Input 6/Addr.6 input (5 V tolerant Input). The function of this pin is determined by the switching configuration enabled. If non-multiplexed CPU bus is used along with a higher input rate of 8.192 or 4.096 Mb/s, this pin provides A6 address input function. For 2.048 and 4.096 Mb/s (8x4) applications or when the multiplexed CPU bus interface is selected, this pin assumes STi6 function. See Control Register bits description and Tables 1, 2, 6 & 7 for more details. Note that for applications where both A6 and STi6 inputs are required simultaneously (e.g., 8 x 4 switching configuration at 4.096 Mb/s or rate conversion between 2.048 Mb/s to 4.196 or 8.192 Mb/s) the A6 input should be connected to pin STo6/A6.
11	11	STi7/A7	ST-BUS Input 7/Addr.7 input (5 V tolerant Input): The function of this pin is determined by the switching configuration enabled. If non-multiplexed CPU bus is used along with a higher input rate of 8.192 Mb/s, this pin provides A7 address input function. For 2.048 and 4.096 Mb/s (8x4) applications or when the multiplexed CPU bus is selected, this pin assumes STi7 function. See Control Register bits description and Tables 1, 2, 6 & 7 for more details. Note that for applications where both A7 and STi7 inputs are required simultaneously (e.g., 2.048 to 8.192 Mb/s rate conversion) the A7 input should be connected to pin STo7/A7.
12	12,36	V_{DD}	+3.3 Volt Power Supply.
	13	\overline{RESET}	Device Reset (5 V tolerant input). This pin is only available for the 48-pin SSOP package. In normal operation, This active low input puts the MT89L86 in its reset state. It clears the internal counters and registers. All ST-BUS outputs are set to the high impedance state. The \overline{RESET} pin must be held low for a minimum of 100nsec to reset the device.
13	14	FR	Frame Pulse (5 V tolerant Input). This input accepts and automatically identifies frame synchronization signals formatted according to ST-BUS and GCI interface specifications.
14	15	CLK	Clock (5 V tolerant Input). Serial clock for shifting data in/out on the serial streams. Depending on the serial interface speed selected by IMS (Interface Mode Select) register, the clock at this pin can be 4.096 or 8.192 MHz.
15-17	16-18	STi8/A0, STi9/A1, STi10/A2	Address 0-2 / Input Streams 8-10 (5 V tolerant Input). When the non-multiplexed CPU bus is selected, these lines provide the A0-A2 address lines to the MT89L86 internal registers. When the 16x8 switching configuration is selected, these pins are ST-BUS serial inputs 8 to 10 receiving data at 2.048 Mb/s.
19-21	20-22	STi11/A3, STi12/A4, STi13/A5	Address 3-5 / Input Streams 11-13 (5 V tolerant Input). When the non-multiplexed CPU bus is selected, these lines provide the A3-A5 address lines to the MT89L86 internal registers. When the 16x8 switching configuration is selected, these pins are ST-BUS serial inputs 11 to 13 receiving data at 2.048 Mb/s.

Pin Description (continued)

Pin #		Name	Description
44 PLCC	48 SSOP		
22	23	DS/ $\overline{\text{RD}}$	Data Strobe/Read (5 V tolerant Input). When the non-multiplexed CPU bus or Motorola multiplexed bus is selected, this input is DS. This active high input works in conjunction with $\overline{\text{CS}}$ to enable read and write operation. For the Intel/National multiplexed bus interface, this input is $\overline{\text{RD}}$. This active low input configures the data bus lines (AD0-7) as outputs.
23	24	R/ $\overline{\text{W}}$ $\overline{\text{WR}}$	Read/Write \ Write (5 V tolerant Input). For the non-multiplexed or Motorola multiplexed bus interface, this input is R/ $\overline{\text{W}}$. This input controls the direction of the data bus lines (AD0-AD7) during a microprocessor access. For the Intel/National multiplexed bus interface, this input is $\overline{\text{WR}}$. This active low signal configures the data bus lines (AD0-7) as inputs.
24	26	$\overline{\text{CS}}$	Chip Select (5 V tolerant Input). This active low input enables a microprocessor read or write of the MT89L86's internal control register or memories.
25-27 29-33	27-29 31-35	AD7-AD0	Data Bus (Bidirectional) : These pins provide microprocessor access to the internal control registers, connection memories high and low and data memories. For the multiplexed bus interface these pins also provide the input address to the internal Address Latch circuit.
34	1, 25,37	V _{SS}	Ground.
35	38	STo7/A7	ST-BUS Output 7/Address 7 input (Three-state output/input). The function of this pin is determined by the switching configuration enabled. If non-multiplexed CPU bus is used along with data rates employing 8.192 Mb/s rates, this pin provides A7 address input function. For 2.048 Mb/s applications or when the multiplexed CPU bus interface is selected, this pin assumes STo7 function. See Tables 1, 2, 6 & 7 for more details. Note that for applications where A7 input and STo7 output are required simultaneously (e.g., 8.192 to 2.048 Mb/s rate conversion), the A7 input should be connected to pin STi7/A7.
36	39	STo6/A6	ST-BUS Output 6/Address 6 input (Three-state output/input) . The function of this pin is determined by the switching configuration enabled. If non-multiplexed CPU bus is used along with a higher data rate employing 8.192 or 4.096 Mb/s, this pin provides the A6 address input function. For 2.048 Mb/s applications or when the multiplexed CPU bus interface is selected, this pin assumes STo6 function. See Tables 1, 2, 6 & 7 for more details. Note that for applications where both A6 input and STo6 output are required simultaneously (e.g., 4.096 to 2.048 Mb/s or 8.192 to 2.048 Mb/s rate conversion applications), the A6 input should be connected to pin STi6/A6.
37-39 41-43	40-42 44-46	STo5-0	ST-BUS Outputs 5 to 0 (Three-state Outputs) . Serial data output streams. These serial streams may be composed of 32, 64 and 128 channels at data rates of 2.048, 4.096 or 8.192 Mbit/s, respectively.
44	47	ODE	Output Drive Enable (5 V tolerant Input) . This is the output enable input for the STo0 to STo9 serial outputs. If this input is low STo0-9 are high impedance. If this input is high each channel may still be set to high impedance by using per-channel control bits in Connect Memory High.

Pin Description (continued)

Pin #		Name	Description
44 PLCC	48 SSOP		
1	48	CSTo	Control ST-BUS Output (Output). This is a 2.048 Mb/s output containing 256 bits per frame. The level of each bit is determined by the CSTo bit in the Connect Memory high locations.
6	6	AS/ALE	Address Strobe or Latch Enable (5 V tolerant Input). This input is only used if multiplexed bus is selected via the IM input pin. The falling edge of this signal is used to sample the address into the address latch circuit. When the non-multiplexed bus interface is selected, this input is not required and should be connected to ground.
18	19	IM	CPU Interface Mode (5 V tolerant Input). If HIGH, this input configures the MT89L86 in the multiplexed microprocessor bus mode. When this input pin is connected to ground, the MT89L86 assumes non-multiplexed CPU interface.
28	30	STi15/ STo9	ST-BUS Input 15 / ST-BUS Output 9 (Input/three-state output). This pin is only used if multiplexed CPU bus is selected. If 16-input x 8-output switching configuration is enabled in the SCB bits (IMS register), this pin is an input receiving serial ST-BUS stream 15 at a data rate of 2.048 Mbit/s. If Stream Pair Selection capability is enabled (see switching configuration section), this pin is the ST-BUS stream 9 output. When non-multiplexed bus structure is used, this pin should be connected to ground.
40	43	STi14/ STo8	ST-BUS Input 14 / ST-BUS Output 8 (Input/three-state output). This pin is only used if multiplexed CPU bus is selected. If 16-input x 8-output switching configuration is enabled in the SCB bits (IMS register), this pin is an input that receives serial ST-BUS stream 14 at a data rate of 2.048 Mbit/s. If Stream Pair Selection capability is enabled (see switching configuration section), this pin is the ST-BUS stream 8 output. When non-multiplexed bus structure is used, this pin should be connected to ground.

Device Overview

With the integration of voice, video and data services in the same network, there has been an increasing demand for systems which ensure that data at N x 64 kb/s rates maintain sequence integrity while being transported through time-slot interchange circuits. This requirement demands time-slot interchange devices which perform switching with constant throughput delay for wideband data applications while maintaining minimum delay for voice channels.

The MT89L86 device meets the above requirement and allows existing systems based on the MT8980D to be easily upgraded to maintain the data integrity when wideband data is transported. The device is designed to switch 32, 64 or N x 64 bit/s data. This MT89L86 can provide frame integrity for data applications and minimum throughput switching delay for voice applications on a per channel basis.

The serial streams of the MT89L86 can operate at 2.048, 4.096 or 8.192 Mbit/s and are arranged in 125 μ s wide frames which contain 32, 64 and 128 channels, respectively. In addition, a built-in rate conversion circuit allows the user to interconnect various backbone speeds like 2.048 or 4.096 or 8.192 Mb/s while maintaining the control of throughput delay function on a per-channel basis.

By using Zarlink Message mode capability, the microprocessor can access input and output time-slots on a per channel basis to control external circuits or other ST-BUS devices. This MT89L86 automatically identifies the polarity of the frame synchronization input signal and configures its serial port to be compatible to both ST-BUS and GCI formats.

Two different microprocessor bus interfaces can be selected through an input mode pin (IM): Non-Multiplexed or Multiplexed. These interfaces provide compatibility with Intel/National multiplexed and Motorola Multiplexed/Non-Multiplexed buses. The MT89L86 provides a 16 x 8 switching configuration to form a 512 x 256 channel blocking matrix. Also, a flexible Stream Pair Selection operation allows the software selection of which pair of input and output streams can be connected to an internal 128 x 128 matrix. See Switching Configurations section for details.

Functional Description

A functional Block Diagram of the 3.3 V MT89L86 is shown in Figure 1. Depending on the application, TDM serial data can be received at different rates and from different number of serial streams.

Data and Connect Memories

For all data rates, the received serial data is converted to parallel format by the serial to parallel converters and stored sequentially in a Data Memory. Depending on the selected operation programmed in the IMS (Interface Mode Select) register, the Data Memory may have up to 512 bytes in use. The sequential addressing of the Data Memory is performed by an internal counter which is reset by the input 8 kHz frame pulse (FR) marking the frame boundaries of the incoming serial data streams.

Data to be output on the serial streams may come from two sources: Data Memory or Connect Memory. Locations in the Connect Memory, which is split into HIGH and LOW parts, are associated with particular ST-BUS output streams. When a channel is due to be transmitted on an ST-BUS output, the data for the channel can either be switched from an ST-BUS input as in connection mode or it can be from the Connect Memory Low as in message mode. Data destined for a particular channel on the serial output stream is read from the Data Memory or Connect Memory Low during the previous channel time-slot. This allows enough time for memory access and parallel to serial conversion.

Connection and Message Modes

In the connection mode, the addresses of the input source data for all output channels are stored in the Connect memories High (CMH) and Low (CML). The CML and CMH are mapped so that each location corresponds to an output channel on the output streams. The number of source address bits in CMH and CML to be utilized varies according to the switching configuration selected in the IMS register. For details on the use of the source address data (CAB and SAB bits), see CMH and CML bit describe-thin (Figures 5 & 6). Once the source address bits are programmed by the CPU, the contents of the Data Memory at the selected address are transferred to the parallel-to-serial converters. By having the output channel specify the source channel through the connect memory, the user can route the same input channel to several output channels, allowing broadcast facility within the switch.

In the message mode the CPU writes data to the Connect Memory Low locations corresponding to the output link and channel number. The contents of the Connect Memory Low are transferred directly to the parallel-to-serial converter one channel before it is to be output. The Connect Memory Low data is transmitted on to the output every frame until it is changed by the CPU with a new data.

The features of each output channel in the 3.3 V MT89L86 are controlled by the Connect Memory High bits. These bits determine individual output channels to be in message or connection mode, select throughput delay types and enable/disable output drivers. The Connect Memory High also provides additional stream and channel address bits for some configurations. In addition, the Connect Memory High provides one bit to allow the user to control the CST output in 2.048 Mb/s applications.

If an output channel is set to high-impedance, the TDM serial stream output will be placed in high impedance during that channel time. In addition to the per-channel control, all channels on the TDM outputs can be placed in high impedance by pulling the ODE input pin LOW. This overrides the individual per-channel programming by the Connect Memory High bits.

The Connect Memory data is received via the Microprocessor Interface through the data I/O lines. The addressing of the MT89L86 internal registers, Data and Connect memories is performed through address input pins and some bits of the device's Control register. The higher order address bits come from the Control register, which may be

written or read through the microprocessor interface. The lower order address bits come directly from address input pins. For details on the device addressing, see Software Control and Control register bits description (Figure 3 & Tables 5, 6 and 7).

Serial Data Interface

The master clock (CLK) can be either at 4.096 or 8.192 MHz allowing serial data link operations at 2.048, 4.096 and 8.192 Mb/s. These data rates can be independently selected on input and output streams allowing this MT89L86 device to be used in various speed backbones and in rate conversion applications. The selected data rates apply to the inputs or the output streams. Different bit rates among input streams or among output streams are not allowed. Due to the I/O data rate selection flexibility, two major operations can be selected: Identical or Different I/O data rates.

The DMO bit (Device Main Operation) in the IMS register is used for selecting between Identical I/O rates or Different I/O rates. On system power-up, the CPU should set up the DMO, the IDR (Input Data Rate) and ODR (Output Data Rate) bits located in the IMS register. When Identical I/O data rates are selected by the DMO bit, the switching configuration and the number of the device's input and output streams can be selected through the SCB bits (Switching Configuration Bits) in the IMS register. See Switching Configurations section for details.

Depending on the application, the interface clock can be selected to be twice the data rate or equal to the data rate. This selection is performed through bit CLKM in the IMS register. For applications where both serial inputs and outputs are at 2.048 Mb/s (ST-BUS or GCI format), the CLKM bit should be set LOW enabling the interface clock to be twice the bit rate. In applications where both inputs and outputs are at 4.096 or 8.192 Mb/s, CLKM should be set HIGH enabling the interface clock to be equal to the bit rate. In applications where inputs and outputs are at different rates, the CLKM bit has no effect.

In applications with serial links at 2.048 Mb/s (see Figures 15 to 18), the input 8 kHz frame pulse can be in either ST-BUS or GCI format. This MT89L86 automatically detects the presence of an input frame pulse and identifies what type of backbone is present on the serial interface. Upon determining the interface connected to the serial port, the internal timing unit establishes the appropriate transmit and sampling edges. In ST-BUS format, every second falling edge of the 4.096 MHz clock marks a bit boundary and the input data is clocked in by the rising edge, three quarters of the way into the bit cell. In GCI format, every second rising edge of the 4.096 MHz clock marks the bit boundary while data sampling is performed during the falling edge, at three quarters of the bit boundaries.

For identical I/O rates at 4.096 and 8.192 Mb/s (see Figure 19), the clock and interface data rates are equal. The bit transmit and sampling edges vary according to the applied frame pulse polarity. For example, if the FR pulse polarity is positive, the bit transmit operation is done on every rising edge of CLK and the bit sampling on every falling edge. If the FR pulse polarity is negative, these edges are inverted. For different I/O rates, the MT89L86 side operating at 2.048 Mb/s data rate will comply with ST-BUS or GCI interfaces for transmit and sampling procedures. The MT89L86 side operating at 4.096 or 8.192 Mb/s behaves according to the frame pulse polarity applied. See Figures 21 to 24.

Switching Configurations

Switching configurations are determined basically by the interface rates selected at the serial inputs and outputs. To specify the switching configuration required, the IMS register has to be initialized on system power-up. In case of Identical I/O rates (DMO bit LOW) at both inputs and outputs, the switching configuration is selected by the two SCB bits as shown in Table 8 (see IMS register). In case of different I/O rates (DMO bit HIGH), the switching configuration is always non-blocking with different number of I/O streams which is defined by the IDR and ODR bits (see IMS register).

Identical Input/Output Data Rates

When identical input/output data rate is selected by the DMO bit, the I/O rate is determined by the IDR0-1 bits, and the ODR0-1 bits are ignored. For each data rate specified by the IDR bits, different switching configurations can be selected in the SCB1-0 bits.

Serial Links with Data Rates at 2.048 Mb/s

When the 2.048 Mb/s data rate is selected at the IDR bits, four different I/O configurations can be selected by the SCB1-0 bits (see Table 8); 8 x 8, 16 x 8, 4 x 4 with stream pair selection and nibble switching.

If 8 x 8 switching configuration is selected, a 256 x 256 channel non-blocking switching matrix is available. In this configuration, the 3.3 V MT89L86 is configured with 8 input and 8 output data streams with 32 64 Kbit/s channels each. The interface clock for this operation is 4.096 MHz with both ST-BUS and GCI compatibilities and the per-channel selection between variable and constant throughput delay functions is provided.

In 16 x 8 switching configuration, a 512 x 256 channel blocking switch matrix is available. This configuration is available only when the CPU bus interface is configured in the multiplexed mode. The device clock in this application is 4.096 MHz, ST-BUS or GCI compatible. This configuration only provides variable throughput delay.

If the stream pair selection switching configuration is selected, only four input and four outputs (4 pairs of serial streams) can be selected by the CPU to be internally connected to the switch matrix, totalling a 128 x 128 channel non-blocking switch. From the 10 serial link pairs available, two pairs are permanently connected to the internal matrix (STi0/STo0 and STi1/STo1). An internal stream pair selection capability allows two additional pairs of serial links to be selected from the remaining 8 pairs (from STi/STo2 to STi9/STo9) and be connected to the internal matrix along with the permanently connected STi0/STo0 and STi1/STo1 streams. The two additional pair of streams called stream pair A and stream pair B, should be selected in the Stream Pair Selection register (SPS). The device clock for this operation is 4.096 MHz compatible to ST-BUS and GCI interfaces. In addition, the per-channel selection between variable or constant throughput delay is available.

In the nibble switching configuration, 4-bit wide 32 Kb/s data channels can be switched within the device. Every serial stream is run at 2.048 Mb/s and transports 64 nibbles per frame. When the Nibble Switching is selected at SCB bits, the 3.3V MT89L86 automatically assumes a 8-input x 4-output stream configuration, providing a blocking switch matrix of 512 x 256 nibbles. If a non-blocking switch matrix is required for nibble switching, the switch capacity is reduced to 256 x 256 channel with a 4 input x 4 output configuration; the non-blocking matrix can be arranged by the user by selecting any four of the 8 input streams. In nibble switching the interface clock is 4.096 MHz.

Serial Links with Data Rates at 4.096 Mb/s

Two I/O configurations can be enabled by the SCB bits when input and output data rates are 4.096 Mb/s on each serial stream: 8 x 4 and 4 x 4. When 8 x 4 switching configuration is selected, a 512 x 256 channel blocking switch is available with serial streams carrying 64, 64 Kb/s channels each. For this operation, a 4.096 MHz interface clock equal to the bit rate should be provided to the 3.3 V MT89L86. Only variable throughput delay mode is provided.

In the 4 x 4 switching configuration, a 256 x 256 channel non-blocking switch is available with serial streams carrying 64, 64 Kb/s channels each. In this configuration, the interface clock is 4.096 MHz and the per-channel selection between variable and constant throughput delay operation is provided. Figure 19 shows the timing for 4.096 Mb/s operation.

Serial Links with Data Rates at 8.192 Mb/s

Only 2 input x 2 output stream configuration is available for 8.192 Mb/s, allowing a 256 x 256 channel non-blocking switch matrix to be implemented. To enable this operation, the IDR bits should be programmed to select 8.192 Mb/s rates and the SCB bits have no effect. At 8.192 Mb/s, every input and output stream provides 128 time-slots per frame. The interface clock for this operation should be 8.192 MHz. Figure 19 shows the timing for 8.192 Mb/s operation.

Table 1 summarizes the 3.3 V MT89L86 switching configurations for identical I/O data rates.

Serial Interface Data Rate	Interface Clock required at CLK Pin (MHz)	Number of Input x Output Streams	Matrix Channel Capacity	Input/Output Streams Used	Variable/Constant Throughput Delay Selection
2 Mb/s	4.096	8x8	256x256 Non-Blocking	STi0-7/STo0-7	Yes
2 Mb/s	4.096	16x8	512x256 Blocking	STi0-15/STo0-7	No
2 Mb/s	4.096	10x10	128x128 Non-Blocking (only 4-input x 4-output can be selected)	STi0-9/STo0-9	Yes
Nibble Switching (2 Mb/s)	4.096	8x4	512x256 Nibbles	STi0-7/STo0-3	No
4 Mb/s	4.096	8x4	512x256 Blocking	STi0-7/STo0-3	No
4 Mb/s	4.096	4x4	256x256 Non-Blocking	STi0-3/STo0-3	Yes
8 Mb/s	8.192	2x2	256x256 Non-Blocking	STi0-1/STo0-1	Yes

Table 1 - Switching Configurations for Identical Input and Output Data Rate

Different Input/Output Data Rates

When Different I/O rate is selected by the DMO bit, the input and output data rates should be selected at the IDR and ODR bits, respectively. The Switching Configuration Bits (SCB) are ignored with this operation. This selection allows the user to multiplex conventional 2.048 Mb/s serial streams into two higher rates and vice-versa. In addition to the rate conversion itself, the MT89L86 allows for a complete 256 x 256 channel non-blocking switch at different rates. In this operation, the per-channel variable/constant throughput delay selection is provided.

Depending on which data rates are programmed for input and output streams, the number of data streams used on the input and output as well as the serial interface clock (CLK input pin) is different. Once the CPU defines the data rates at the IDR and ODR bits, the MT89L86 automatically configures itself with the appropriate number of input and output streams for the desired operation. Table 2 summarizes the four options available when it is used with different I/O rates. Figures 21 to 24 show the timing for each of the four modes shown in Table 2.

Input and Output Data Rates	Interface Clock required at CLK Pin (MHz)	Number of Input x Output Streams	Matrix Channel Capacity	Input/Output Streams Used	Variable/Constant throughput Delay Selection
2 Mb/s to 4 Mb/s	4.096	8x4	256x256 Non-Blocking	STi0-7/STo0-3	Yes
2 Mb/s to 8 Mb/s	8.192	8x2	256x256 Non-Blocking	STi0-7/STo0-1	Yes
4 Mb/s to 2 Mb/s	4.096	4x8	256x256 Non-Blocking	STi0-3/STo0-7	Yes
8 Mb/s to 2 Mb/s	8.192	2x8	256x256 Non-Blocking	STi0-1/STo0-7	Yes

Table 2 - Switching Configurations for Different I/O Data Rates

Input Frame Offset Selection

For the 4.096 and 8.192 Mb/s serial interface data rates, the MT89L86 provides a feature called Input Frame Offset allowing the user to compensate for the varying delays at the incoming serial inputs while building large switch matrices. Usually, different delays occur on the digital backbones causing the data and frame synchronization

signals to be skewed at the input of the switch device. This may result in the system frame synchronization pulse to be active at the MT89L86's FR input before the first bit of the frame is received at the serial inputs.

When the input frame offset is enabled, an "internal delay" of up to four clock periods is added to the actual data input sampling, providing the MT89L86 serial timing unit a new input frame reference. An internal virtual frame is created which is aligned with the framing of the actual serial data coming in at the serial inputs and not with the FR frame pulse input. In this operation, the transmission of the output frame on the serial links is still aligned to the frame pulse input signal (FR).

The selection of the data input sampling delay is defined by the CPU in the Frame Input Offset Register (FIO). If this function is not required in the user's applications, the FIO register should be set up during system initialization to a state where offset functions are disabled.

Delay Through the MT89L86

The switching of information from the input serial streams to the output serial streams results in a delay. Depending on the type of information to be switched, this MT89L86 can be programmed to perform time-slot interchange functions with different throughput delay capabilities on a per-channel basis. For voice applications, variable throughput delay can be selected ensuring minimum delay between input and output data. In wideband data applications, constant throughput delay can be selected maintaining the frame integrity of the information through the switch.

The delay through the device varies according to the type of throughput delay selected in the $\overline{V/C}$ bit of the connect memory high.

Variable Throughput Delay Mode ($\overline{V/C}$ bit = 0)

Identical I/O Data Rates

The delay in this mode is dependent on the combination of source and destination channels and it is independent of the input and output streams. The minimum delay achievable in this MT89L86 depends on the data rate selected for the serial streams. For instance, for the 2.048 Mb/s data rate, the minimum delay achieved corresponds to three time-slots. For the 4.096 Mb/s data rate it corresponds to five time-slots while it is nine time-slots for the 8.192 Mb/s data rate. Switching configurations with input and output channels that provides more than its corresponding minimum throughput delay, will have a throughput delay equal to the difference between the output and input channels; i.e., the throughput delay will be less than one frame period. Table 3a shows the throughput delay for each data rate operation.

Different I/O Data Rates

Except for the 2 Mb/s to 4 Mb/s and the 2 Mb/s to 8 Mb/s rate conversion operations, the throughput delay from the MT89L86 may vary according to the output stream used for switching.

Table 3b explains the worst case conditions for the throughput delay when different I/O data rate switching configurations are used.

Input Rate	Output Channel (# m)				
	m < n	m=n, n+1, n+2	m= n+3, n+4	m=n+5, .. n+8	m > n+8
2.048 Mb/s	32-(n-m) t.s.	m-n + 32 t.s.	m-n t.s.	m-n t.s.	m-n t.s.
4.096 Mb/s	64-(n-m) t.s.	m-n + 64 t.s.	m-n+64 t.s.	m-n t.s.	m-n t.s.
8.192 Mb/s	128-(n-m) t.s.	m-n + 128 t.s.	m-n+128 t.s.	m-n+128 t.s.	m-n t.s.

Table 3a - Variable Throughput Delay Values for Identical I/O Rate Applications

n= input channel, t.s. = time-slot

I/O Data Rate Configuration	Output Stream Used			
	0, 1	2, 3	4, 5	6, 7
2 Mb/s to 4 Mb/s	dmin=5x 4Mb/s t.s. dmax=1 fr.+(4x 4Mb/s t.s.)			
2 Mb/s to 8 Mb/s	dmin=9x 8Mb/s t.s. dmax=1 fr.+(8x 8Mb/s t.s.)			
4 Mb/s to 2 Mb/s	dmin=3x 2Mb/s t.s. dmax=1 fr.+(2x 2Mb/s t.s.)		dmin=(2x 2Mb/s t.s.)+(1x 4Mb/s t.s.) dmax=1 fr.+(1x 2Mb/s t.s.)+(1x 4Mb/s t.s.)	
8 Mb/s to 2 Mb/s	dmin=3x 2Mb/s t.s. dmax=1 fr.+(2x 2Mb/s t.s.)	dmin=(2x 2Mb/s t.s.)+(3x 8Mb/s t.s.) dmax=1 fr.+(1x 2Mb/s t.s.)+(3x 8Mb/s t.s.)	dmin=(2x 2Mb/s t.s.)+(2x 8Mb/s t.s.) dmax=1 fr.+(1x 2Mb/s t.s.)+(2x 8Mb/s t.s.)	dmin=(2x 2Mb/s t.s.)+(1x 8Mb/s t.s.) dmax=1 fr.+(1x 2Mb/s t.s.)+(1x 8Mb/s t.s.)

Table 3b - Min/Max Throughput Delay Values for Different I/O Rate Applications

Notes: dmin and dmax are measured in time-slots and at the point in time when the output channel is completely shifted out.

t.s. = time-slot
fr. = 125 μ s frame
2 Mb/s t.s. = 3.9 μ s
4 Mb/s t.s. = 1.95 μ s
8 Mb/s t.s. = 0.975 μ s

Constant Throughput Delay mode (\bar{V}/C bit = 1)

In this mode frame sequence integrity is maintained in both Identical and Different I/O Data Rate operations by making use of a multiple Data-Memory buffer technique. The input channels written in any of the buffers during frame N will be read out during frame N+2. In applications at 2.048 Mb/s for instance, the minimum throughput delay achievable in constant delay mode will be 32 time-slots; for example, when input time-slot 32 (channel 31) is switched to output time-slot 1 (channel 0). Likewise, the maximum delay is achieved when the first time slot in a frame (channel 0) is switched to the last time-slot in the frame (channel 31), resulting in 94 time-slots of delay.

To summarize, any input time-slot from input frame N will always be switched to the destination time-slot on output frame N+2. Table 4 describes the constant throughput delay values at different data rates.

Data Rate	Throughput Delay (d)
2.048 Mb/s	$d=[32 + (32 - IN) + (OUT - 1)]$; (expressed in # time-slots) 2.048 Mb/s time-slot: 3.9 μ s IN: input time-slot (from 1 to 32) OUT: output time-slot (from 1 to 32)
4.096 Mb/s	$d=[64 + (64 - IN) + (OUT - 1)]$; (expressed in # time-slots) 4.096 Mb/s time-slot: 1.95 μ s IN: input time-slot (from 1 to 64) OUT: output time-slot (from 1 to 64)
8.192 Mb/s	$d=[128 + (128 - IN) + (OUT - 1)]$; (expressed in # time-slots) 8.192 Mb/s time-slot: 0.975 μ s IN: input time-slot (from 1 to 128) OUT: output time-slot (from 1 to 128)

Table 4 - Constant Throughput Delay Values

Microprocessor Port

The non-multiplexed bus interface provided by the MT89L86 is identical to that provided in the MT8986 Digital Switch device. In addition to the non-multiplexed bus, this 3.3 V MT89L86 device provides an enhanced microprocessor interface with multiplexed bus structure compatible to both Motorola and Intel buses. The multiplexed bus structure is selected by the CPU Interface Mode (IM) input pin.

If the IM input pin is connected to ground, the MT89L86's parallel port assumes its default Motorola non-multiplexed bus mode identical to that of MT8986. If the IM input is connected HIGH, the internal parallel microprocessor port provides compatibility to MOTEL (**M**otorola and **InTEL** compatible bus) interface allowing direct connection to Intel, National and Motorola CPUs.

The on-chip MOTEL circuit automatically identifies the type of CPU Bus connected to the device. This circuit uses the level of the DS/RD input pin at the rising edge of the AS/ALE to identify the appropriate bus timing connected to the MT89L86. If DS/RD is LOW at the rising edge of AS/ALE then the Motorola bus timing is selected. If DS/RD is HIGH at the rising edge of AS/ALE, the Intel bus timing is selected.

When the parallel port of this device is operating in Motorola, National or Intel multiplexed bus interfaces, the signals available for controlling the device are: AD0-AD7 (Data and Address), ALE/AS (Address Latch Enable/Address Strobe), DS/RD (Data Strobe/Read), R/W\WR (Read/Write/Write), CS (Chip Select) and DTA (Data Acknowledgment). In the Motorola non-multiplexed bus mode, the interface control signals are: data bus (AD0-AD7), six address input lines (A0-A5) and four control lines (CS, DS, R/W and DTA). See Figures 25 to 27 for each CPU interface timing.

The parallel microprocessor port provides the access to the IMS, Control registers, the Connection Memory High, the Connection Memory Low and the Data Memory. All locations can be read or written except for the data memory which can be read only.

Software Control

The address bus on the microprocessor interface selects the internal registers and memories of the MT89L86. If the A5 address input is LOW, the Internal Control, Interface Mode, Stream Pair Selection and Frame Input Offset registers are addressed by the A4 to A0 bits according to Table 5. If the A5 input is HIGH, the remaining address input lines are used to select memory subsections of up to 128 locations corresponding to the maximum number of channels per input or output stream. The address input lines and the Stream Address bits (STA) of the Control register give the user the capability of accessing all sections of the MT89L86's Data and Connect memories.

The Control and Interface Mode Selection registers together control all the major functions of the device. The Interface Mode Select register should be set up during system power-up to establish the desired switching configuration as explained in the Serial Interface and Switching Configurations sections.

The Control register is dynamically used by the CPU to control switching operations in the MT89L86. The Control register selects the device's internal memories and its subsections to specify the input and output channels selected for switching procedures.

The data in the Control register consists of Split memory and Message mode bits, Memory select and Stream Address bits. The memory select bits allow the Connect Memory HIGH or LOW or the Data Memory to be chosen, and the Stream Address bits define an internal memory subsections corresponding to input or output ST-BUS streams.

Bit 7 (Slip Memory) of the Control register allows split memory operation whereby reads are from the Data memory and writes are to the Connect Memory LOW.

The Message Enable bit (bit 6) places every output channel on every output stream in message mode; i.e., the contents of the Connect Memory LOW (CML) are output on the ST-BUS output streams once every frame unless the ODE input pin is LOW. If ME bit is HIGH, then the MT89L86 behaves as if bits 2 (Message Channel) and 0 (Output Enable) of every Connect Memory HIGH (CMH) locations were set to HIGH, regardless of the actual value. If ME bit is LOW, then bit 2 and 0 of each Connect Memory HIGH location function normally. For example, if bit 2 of the CMH is HIGH, the associated ST-BUS output channel is in Message mode. If bit 2 of the CMH is LOW, then the contents of the SAB and CAB bits of the CMH and CML define the source information (stream and channel) of the time-slot that is to be switched to an output.

If the ODE input pin is LOW, then all serial outputs are set to high impedance. If ODE is HIGH, then bit 0 (Output Enable) of the CMH location enables (if HIGH) or disables (if LOW) the output drivers for the corresponding individual ST-BUS output stream and channel.

The contents of bit 1 (CSTo bit) of each Connection Memory High location is output to the CSTo pin once every frame. The CSTo pin is a 2048 Mbit/s output which carries 256 bits. If CSTo bit is set HIGH, the corresponding bit on CSTo output is transmitted HIGH. If CSTo bit is LOW, the corresponding bit on the CSTo output is transmitted LOW. The contents of the 256 CSTo bits of the CMH are transmitted sequentially to the CSTo output pin and are synchronous to the 2.048 Mb/s ST-BUS streams. To allow for delay in any external control circuitry the contents of the CSTo bit is output one channel before the corresponding channel on the ST-BUS streams. For example, the contents of CSTo bit in position 0 (ST0, CH0) of the CMH, is transmitted synchronously with ST-BUS channel 31, bit 7. The contents of CSTo bit in position 32 (ST1, CH0) of the CMH is transmitted during ST-BUS channel 31 bit 6. For more detailed description of the CSTo operation, see section 6 of Application Note MSAN-123.

The \overline{V}/C bit (Variable/Constant Delay) of each Connect Memory High location allows the per-channel selection between Variable and Constant throughput delay modes.

Initialization of the MT89L86

On initialization or power up, the contents of the Connection Memory High can be in any state. This is a potentially hazardous condition when multiple MT89L86 ST-BUS outputs are tied together to form matrices, as these outputs may conflict. The ODE pin should be held low on power up to keep all outputs in the high impedance condition.

During the microprocessor initialization routine, the microprocessor should program the desired active paths through the matrices, and put all other channels into the high impedance state. Care should be taken that no two ST-BUS outputs drive the bus simultaneously. When this process is complete, the microprocessor controlling the matrices can bring the ODE signal high to relinquish the high impedance state control to the OE bit of the CMH (CMH_b0s).

A \overline{RESET} pin is available for the 48-pin SSOP package. When this pin is set low for a minimum of 100 n sec, the ST-BUS outputs are put to the high impedance state and all register contents are set to zero.

A7	A6	A5	A4	A3	A2	A1	A0	Location
X	X	0	0	0	0	0	0	Control Register
X	X	0	0	0	0	0	1	Interface Mode Select Register
X	X	0	0	0	0	1	0	Stream Pair Select Register
X	X	0	0	0	0	1	1	Frame Input Offset Register
0	0	1	0	0	0	0	0	Channel 0*
0	0	1	0	0	0	0	1	Channel 1*
•	•	1	•	•	•	•	•	•
•	•	1	•	•	•	•	•	•
0	0	1	1	1	1	1	1	Channel 31*
0	1	1	0	0	0	0	0	Channel 32**
0	1	1	0	0	0	0	1	Channel 33**
•	•	1	•	•	•	•	•	•
•	•	1	•	•	•	•	•	•
0	1	1	1	1	1	1	1	Channel 63**
1	0	1	0	0	0	0	0	Channel 64***
•	•	1	•	•	•	•	•	•
•	•	1	•	•	•	•	•	•
1	1	1	1	1	1	1	1	Channel 127***

Table 5 - Address Memory Map

* channels 0 to 31 are used in 2.048 Mb/s (8 x 8, 16 x 8 and 10 x 10)

** channels 0 to 63 are used in 4.096 Mb/s (Nibble Switching, 4 x 4, 8 x 4 or Different I/O rates)

*** channels 0 to 127 are used in 8.192 Mb/s (2 x 2 or Different I/O rates)

Control Register - Read/Write

<table border="1" style="margin-left: auto; margin-right: auto;"> <tr> <td style="text-align: center;">7</td> <td style="text-align: center;">6</td> <td style="text-align: center;">5</td> <td style="text-align: center;">4</td> <td style="text-align: center;">3</td> <td style="text-align: center;">2</td> <td style="text-align: center;">1</td> <td style="text-align: center;">0</td> </tr> <tr> <td style="text-align: center;">SM</td> <td style="text-align: center;">ME</td> <td style="text-align: center;">STA3</td> <td style="text-align: center;">MS1</td> <td style="text-align: center;">MS0</td> <td style="text-align: center;">STA2</td> <td style="text-align: center;">STA1</td> <td style="text-align: center;">STA0</td> </tr> </table>			7	6	5	4	3	2	1	0	SM	ME	STA3	MS1	MS0	STA2	STA1	STA0
7	6	5	4	3	2	1	0											
SM	ME	STA3	MS1	MS0	STA2	STA1	STA0											
Bit	Name	Description																
7	SM	Split Memory. When 1, all subsequent reads are from the Data Memory and writes are to the Connection Memory Low, except when the Control Register is accessed again. When 0, the Memory Select bits specify the memory for subsequent operations. In either case, the Stream Address Bits select the subsection of the memory which is made available.																
6	ME	Message Enable. When 1, the contents of the Connection Memory Low are output on the Serial Output streams except when in High Impedance as set by the ODE input. When 0, the Connection Memory bits for each channel determine the output of the serial streams.																
5	STA3	Stream Address Bit 3. When the 16 x 8 switching configuration is selected, this pin is used with STA2-0 to select one of the 16 input data streams whenever the Data Memory is to be read. The programming of this bit has no effect in other switching configurations.																
4-3	MS1-0	Memory Select Bits. The memory select bits operate as follows: 0-0 - Not to be used 0-1 - Data Memory (read only from the CPU) 1-0 - Connection Memory Low 1-1 - Connection Memory High																
2-0	STA2-0	The number expressed in binary notation on these bits refers to the input or output ST-BUS stream which corresponds to the subsection of memory made accessible for subsequent operations. The use of these bits depends on the switching configuration as well as the device's main operation defined by the DMO bit of the Interface Mode Selection register. Tables 6 and 7 show the utilization of these bits according to the device's main operation.																

Figure 3 - Control Register Description

Identical I/O Rate	# of Input x Output Streams	STA bits used to select subsections of the Data Memory	STA bits used to select subsections of the Connection Memory	Input Address pins used to select individual Connection and Data Memory positions within the selected subsection
2 Mb/s	8x8	STA2, STA1, STA0	STA2, STA1, STA0	A4, A3, A2, A1, A0
2 Mb/s	4x4	STA1, STA0	STA1, STA0	A4, A3, A2, A1, A0
2 Mb/s	16x8	STA3, STA2, STA1, STA0	STA2, STA1, STA0	A4, A3, A2, A1, A0
4 Mb/s	4x4	STA1, STA0	STA1, STA0	A6, A4, A3, A2, A1, A0
4 Mb/s	8x4	STA2, STA1, STA0	STA1, STA0	A6, A4, A3, A2, A1, A0
8 Mb/s	2x2	STA0	STA0	A7, A6, A4, A3, A2, A1, A0
Nibble Switch (2 Mb/s)	8x4	STA2, STA1, STA0	STA1, STA0	A6, A4, A3, A2, A1, A0 *

Table 6 - Use of STA Bits for Identical I/O Data Rate Operation

* - for Data Memory Read operations A0 is not required since two nibbles are provided per read access.

Different I/O Rate	Input x Output Streams Config.	STA bits used to select Data Memory subsections	STA bits used to select Connection Memory subsections	Input Address pins used to access individual Data Memory positions within the selected subsection	Input Address pins used to access individual Connection Memory positions within the selected subsection
2 Mb/s to 4 Mb/s	8x4	STA2, STA1, STA0	STA1, STA0	A4, A3, A2, A1, A0	A6, A4, A3, A2, A1, A0
2 Mb/s to 8 Mb/s	8x2	STA2, STA1, STA0	STA0	A4, A3, A2, A1, A0	A7, A6, A4, A3, A2, A1, A0
4 Mb/s to 2 Mb/s	4x8	STA1, STA0	STA2, STA1, STA0	A6, A4, A3, A2, A1, A0	A4, A3, A2, A1, A0
8 Mb/s to 2 Mb/s	2x8	STA0	STA2, STA1, STA0	A7, A6, A4, A3, A2, A1, A0	A4, A3, A2, A1, A0

Table 7 - Use of STA Bits for Different I/O Data Rate Operation

Note: In rate conversion applications, Data Memory subsections have different sizes than Connection Memory subsections. This implies that different address inputs are used to select individual positions within the subsections for each type of memory.

Interface Mode Selection Register - Read/Write

Bit	Name	Description																
<table border="1" style="margin: auto; border-collapse: collapse;"> <tr> <td style="width: 12.5%; text-align: center;">7</td> <td style="width: 12.5%; text-align: center;">6</td> <td style="width: 12.5%; text-align: center;">5</td> <td style="width: 12.5%; text-align: center;">4</td> <td style="width: 12.5%; text-align: center;">3</td> <td style="width: 12.5%; text-align: center;">2</td> <td style="width: 12.5%; text-align: center;">1</td> <td style="width: 12.5%; text-align: center;">0</td> </tr> <tr> <td style="text-align: center;">DMO</td> <td style="text-align: center;">IDR1</td> <td style="text-align: center;">IDR0</td> <td style="text-align: center;">ODR1</td> <td style="text-align: center;">ODR0</td> <td style="text-align: center;">SCB1</td> <td style="text-align: center;">SCB0</td> <td style="text-align: center;">CLKM</td> </tr> </table>			7	6	5	4	3	2	1	0	DMO	IDR1	IDR0	ODR1	ODR0	SCB1	SCB0	CLKM
7	6	5	4	3	2	1	0											
DMO	IDR1	IDR0	ODR1	ODR0	SCB1	SCB0	CLKM											
7	DMO	<p>Device Main Operation. This bit is used by the CPU to define one of the two main operations of the 3.3 V MT89L86. If this bit is LOW, the MT89L86 is configured for identical I/O data rates. For this operation, the user should also specify the switching configuration through the SCB bits.</p> <p>If this bit is HIGH, the MT89L86 is configured in Different I/O data rate. This allows combinations of input and output data rates as shown in Table 2. The SCB bits have no effect in this application and the device is in Non-Blocking switch configuration with a 256 x 256 channel capacity.</p>																
6-5	IDR1-0	<p>Input Data Rate Selection. These two bits select three different data rates for the inputs of the MT89L86. In the case of identical I/O rates (DMO bit = 0), these bits also determine the serial output data rate.</p> <table style="margin-left: auto; margin-right: auto; border-collapse: collapse;"> <thead> <tr> <th style="text-align: center;"><u>IDR1</u></th> <th style="text-align: center;"><u>IDR0</u></th> <th style="text-align: center;"><u>Input Rate</u></th> </tr> </thead> <tbody> <tr> <td style="text-align: center;">0</td> <td style="text-align: center;">0</td> <td style="text-align: center;">2.048 Mb/s</td> </tr> <tr> <td style="text-align: center;">0</td> <td style="text-align: center;">1</td> <td style="text-align: center;">4.096 Mb/s</td> </tr> <tr> <td style="text-align: center;">1</td> <td style="text-align: center;">0</td> <td style="text-align: center;">8.192 Mb/s</td> </tr> <tr> <td style="text-align: center;">1</td> <td style="text-align: center;">1</td> <td style="text-align: center;">reserved</td> </tr> </tbody> </table>	<u>IDR1</u>	<u>IDR0</u>	<u>Input Rate</u>	0	0	2.048 Mb/s	0	1	4.096 Mb/s	1	0	8.192 Mb/s	1	1	reserved	
<u>IDR1</u>	<u>IDR0</u>	<u>Input Rate</u>																
0	0	2.048 Mb/s																
0	1	4.096 Mb/s																
1	0	8.192 Mb/s																
1	1	reserved																
4-3	ODR1-0	<p>Output Data Rate Selection. These bits are only used when Different I/O rates are selected (DMO bit=1). These two bits select three different data rates for the serial outputs of the MT89L86. These bits are ignored if DMO bit = 0.</p> <table style="margin-left: auto; margin-right: auto; border-collapse: collapse;"> <thead> <tr> <th style="text-align: center;"><u>ODR1</u></th> <th style="text-align: center;"><u>ODR0</u></th> <th style="text-align: center;"><u>Output Rate</u></th> </tr> </thead> <tbody> <tr> <td style="text-align: center;">0</td> <td style="text-align: center;">0</td> <td style="text-align: center;">2.048 Mb/s</td> </tr> <tr> <td style="text-align: center;">0</td> <td style="text-align: center;">1</td> <td style="text-align: center;">4.096 Mb/s</td> </tr> <tr> <td style="text-align: center;">1</td> <td style="text-align: center;">0</td> <td style="text-align: center;">8.192 Mb/s</td> </tr> <tr> <td style="text-align: center;">1</td> <td style="text-align: center;">1</td> <td style="text-align: center;">reserved</td> </tr> </tbody> </table>	<u>ODR1</u>	<u>ODR0</u>	<u>Output Rate</u>	0	0	2.048 Mb/s	0	1	4.096 Mb/s	1	0	8.192 Mb/s	1	1	reserved	
<u>ODR1</u>	<u>ODR0</u>	<u>Output Rate</u>																
0	0	2.048 Mb/s																
0	1	4.096 Mb/s																
1	0	8.192 Mb/s																
1	1	reserved																
2-1	SCB1-0	<p>Switching Configuration Bits 1-0. These bits should only be used when DMO is set LOW. The use of these bits to select the switching configuration of the MT89L86 is described in Table 8.</p>																
0	CLKM	<p>Clock Mode. This bit is only used when the MT89L86 is set to operate in identical I/O data rates. When set High, this bit selects the interface clock to be equal to the bit rate. If Low, this bit selects the interface clock to be twice the bit rate. For Different I/O data rate applications, this bit is ignored.</p>																

Figure 4 - IMS Register Description

DMO Bit	Data Rate Selected at IDR bits (Mb/s)	SCB1	SCB0	Configuration
LOW Identical I/O Rates	2.048	0	0	8 inputs x 8 outputs - Non Blocking
		0	1	16 inputs x 8 outputs - Blocking
		1	0	Stream pair selection capability (internal channel capacity = 128 x 128) - Non Blocking
		1	1	Nibble Switching - 8 inputs x 4 outputs - Blocking
	4.096	0	0	8 inputs x 4 outputs - Blocking
		0	1	4 inputs x 4 outputs - Non-Blocking
		1	0	Reserved
		1	1	Reserved
	8.192	no effect	no effect	2 inputs x 2 outputs - Non-Blocking
	HIGH Different I/O Rates	Input/Output Rate selected in IDR/ODR bits	no effect	no effect

Table 8 - Switching Configurations for Identical I/O Rates

Connection Memory High - Read/Write

<table border="1" style="margin: auto;"> <tr> <td style="text-align: center;">7</td> <td style="text-align: center;">6</td> <td style="text-align: center;">5</td> <td style="text-align: center;">4</td> <td style="text-align: center;">3</td> <td style="text-align: center;">2</td> <td style="text-align: center;">1</td> <td style="text-align: center;">0</td> </tr> <tr> <td style="text-align: center;">X</td> <td style="text-align: center;">\bar{V}/C</td> <td style="text-align: center;">SAB3</td> <td style="text-align: center;">CAB6</td> <td style="text-align: center;">CAB5</td> <td style="text-align: center;">MC</td> <td style="text-align: center;">CSTo</td> <td style="text-align: center;">OE</td> </tr> </table> <p style="text-align: center;">(CM high bits)</p>								7	6	5	4	3	2	1	0	X	\bar{V}/C	SAB3	CAB6	CAB5	MC	CSTo	OE
7	6	5	4	3	2	1	0																
X	\bar{V}/C	SAB3	CAB6	CAB5	MC	CSTo	OE																
Bit	Name	Description																					
6	\bar{V}/C	Variable/Constant Throughput Delay Mode. This bit is used to select between Variable (LOW) and Constant Delay (HIGH) modes in a per-channel basis. Tables 1 and 2 describe the switching configurations that have this function. In the modes where this function is not available, this bit ignored.																					
5	SAB3	Source Stream Address bit 3. This bit is used along with bits SAB0-2 in CML to select up to 16 different source streams for the connection. Depending on the state of DMO bit and the switching configuration enabled, not all SAB3-0 bits have to be used. See Tables 9 and 10 for details on the utilization of the SAB bits.																					
4-3	CAB6-5	Source Channel Address bits 5 and 6. These two bits are used together with bits CAB0-4 in Connect Memory Low to select up 128 different source channels for the connection. Depending on the data rate used in the input/output streams, 5, 6 or all 7 CAB bits can be used respectively, to select 32, 64 or 128 different channels. See Tables 9 and 10 for details on the utilization of the CAB bits.																					

<table border="1" style="margin: auto; border-collapse: collapse;"> <tr> <td style="width: 12.5%;">7</td> <td style="width: 12.5%;">6</td> <td style="width: 12.5%;">5</td> <td style="width: 12.5%;">4</td> <td style="width: 12.5%;">3</td> <td style="width: 12.5%;">2</td> <td style="width: 12.5%;">1</td> <td style="width: 12.5%;">0</td> </tr> <tr> <td>X</td> <td>\bar{V}/C</td> <td>SAB3</td> <td>CAB6</td> <td>CAB5</td> <td>MC</td> <td>CSTo</td> <td>OE</td> </tr> </table> <p>(CM high bits)</p>								7	6	5	4	3	2	1	0	X	\bar{V}/C	SAB3	CAB6	CAB5	MC	CSTo	OE
7	6	5	4	3	2	1	0																
X	\bar{V}/C	SAB3	CAB6	CAB5	MC	CSTo	OE																
Bit	Name	Description																					
2	MC	Message Channel. When 1, the contents of the corresponding location in Connection Memory Low are output on the corresponding channel and stream. When 0, the contents of the programmed location in Connection Memory Low act as an address for the Data Memory and so determine the source of the connection to the location's channel and stream.																					
1	CSTo	CSTo Bit. This bit is only available in 2.048 Mb/s applications. It drives a bit time on the CSTo output pin.																					
0	OE	Output Enable. This bit enables the output drivers on a per-channel basis. This allows individual channels on individual streams to be made high-impedance, allowing switch matrices to be constructed. A HIGH enables the driver and a LOW disables it.																					

Figure 5 - Connection Memory High (CMH) Bits

x=Don't care

Connection Memory Low - Read/Write

<table border="1" style="margin: auto; border-collapse: collapse;"> <tr> <td style="width: 12.5%;">7</td> <td style="width: 12.5%;">6</td> <td style="width: 12.5%;">5</td> <td style="width: 12.5%;">4</td> <td style="width: 12.5%;">3</td> <td style="width: 12.5%;">2</td> <td style="width: 12.5%;">1</td> <td style="width: 12.5%;">0</td> </tr> <tr> <td>SAB2</td> <td>SAB1</td> <td>SAB0</td> <td>CAB4</td> <td>CAB3</td> <td>CAB2</td> <td>CAB1</td> <td>CAB0</td> </tr> </table> <p>(CM low bits)</p>								7	6	5	4	3	2	1	0	SAB2	SAB1	SAB0	CAB4	CAB3	CAB2	CAB1	CAB0
7	6	5	4	3	2	1	0																
SAB2	SAB1	SAB0	CAB4	CAB3	CAB2	CAB1	CAB0																
Bit	Name	Description																					
7-5	SAB2-0*	Source Stream Address bits. These three bits are used together with SAB3 in CMH to select up to 16 different source streams for the connection. Depending on the switching configuration and the data rate selected in the application, 1, 2, 3 or all 4 SAB bits can be used. See Tables 9 and 10 for details.																					
4-0	CAB4-0*	Source Channel Address bits 0-4. These five bits are used together with CAB5-6 in CMH to select up 128 different source channels for the connection. Depending on the switching configuration and the data rate used in the application, 5, 6 or all 7 CAB bits can be used to select respectively 32, 64 or 128 different channels. See Tables 9 and 10 for details.																					
<p>If bit two (MC) of the corresponding Connection High locations is 1, or if bit 6 of the Control Register is 1, then these entire eight bits are output on the corresponding output channel and stream associated with this location. Otherwise, the bits are used as indicated to define the source of the connection which is output on the channel and stream associated with this location.</p>																							

Figure 6 - Connection Memory Low (CML) Bits

Identical I/O Rate	# of Input x Output Streams	CAB bits used to determine the source channel for the connection	SAB bits used to determine the source stream for the connection
2 Mb/s	8x8	CAB4 to CAB0 (32 channel/stream)	SAB2, SAB1, SAB0
2 Mb/s	4x4	CAB4 to CAB0 (32 channel/stream)	SAB2, SAB1
2 Mb/s	16x8	CAB4 to CAB0 (32 channel/stream)	SAB3, SAB2, SAB1, SAB0
4 Mb/s	4x4	CAB5 to CAB0 (64 channel/stream)	SAB2, SAB1
4 Mb/s	8x4	CAB5 to CAB0 (64 channel/stream)	SAB2, SAB1, SAB0
8 Mb/s	2x2	CAB6 to CAB0 (128 channel/stream)	SAB2
Nibble Switch (2 Mb/s)	8x4	CAB5 to CAB0 (64 nibble/stream)	SAB2, SAB1, SAB0

Table 9 - CAB and SAB Bits Programming for Identical I/O Rate Applications

Different I/O Rate	# of Input x Output Streams	CAB bits used to determine the source channel for the connection	SAB bits used to determine the source stream for the connection
2 Mb/s to 4 Mb/s	8x4	CAB4 to CAB0 (32 channel/stream)	SAB2, SAB1, SAB0
2 Mb/s to 8 Mb/s	8x2	CAB4 to CAB0 (32 channel/stream)	SAB2, SAB1, SAB0
4 Mb/s to 2 Mb/s	4x8	CAB5 to CAB0 (64 channel/stream)	SAB2, SAB1
8 Mb/s to 2 Mb/s	2x8	CAB6 to CAB0 (128 channel/stream)	SAB2

Table 10 - CAB and SAB Bits Programming for Different I/O Rate Applications

Stream Pair Selection Register - Read/Write

<table border="1" style="margin-left: auto; margin-right: auto;"> <tr> <td style="text-align: center;">7</td> <td style="text-align: center;">6</td> <td style="text-align: center;">5</td> <td style="text-align: center;">4</td> <td style="text-align: center;">3</td> <td style="text-align: center;">2</td> <td style="text-align: center;">1</td> <td style="text-align: center;">0</td> </tr> <tr> <td style="text-align: center;">X</td> <td style="text-align: center;">X</td> <td style="text-align: center;">SPA2</td> <td style="text-align: center;">SPA1</td> <td style="text-align: center;">SPA0</td> <td style="text-align: center;">SPB2</td> <td style="text-align: center;">SPB1</td> <td style="text-align: center;">SPB0</td> </tr> </table>								7	6	5	4	3	2	1	0	X	X	SPA2	SPA1	SPA0	SPB2	SPB1	SPB0																				
7	6	5	4	3	2	1	0																																				
X	X	SPA2	SPA1	SPA0	SPB2	SPB1	SPB0																																				
Bit	Name	Description																																									
5-3	SPA2-0	<p>Stream Pair A selection. These three bits define which pair of streams are going to be connected to the switch matrix, together with the permanently connected streams STi0-1 / STo0-1.</p> <table border="1" style="margin-left: auto; margin-right: auto;"> <thead> <tr> <th>SPA2</th> <th>SPA1</th> <th>SPA0</th> <th>Stream Pair A Connected</th> </tr> </thead> <tbody> <tr><td>0</td><td>0</td><td>0</td><td>STi2 / STo2</td></tr> <tr><td>0</td><td>0</td><td>1</td><td>STi3 / STo3</td></tr> <tr><td>0</td><td>1</td><td>0</td><td>STi4 / STo4</td></tr> <tr><td>0</td><td>1</td><td>1</td><td>STi5 / STo5</td></tr> <tr><td>1</td><td>0</td><td>0</td><td>STi6 / STo6</td></tr> <tr><td>1</td><td>0</td><td>1</td><td>STi7 / STo7</td></tr> <tr><td>1</td><td>1</td><td>0</td><td>STi8 / STo8</td></tr> <tr><td>1</td><td>1</td><td>1</td><td>STi9 / STo9</td></tr> </tbody> </table>						SPA2	SPA1	SPA0	Stream Pair A Connected	0	0	0	STi2 / STo2	0	0	1	STi3 / STo3	0	1	0	STi4 / STo4	0	1	1	STi5 / STo5	1	0	0	STi6 / STo6	1	0	1	STi7 / STo7	1	1	0	STi8 / STo8	1	1	1	STi9 / STo9
SPA2	SPA1	SPA0	Stream Pair A Connected																																								
0	0	0	STi2 / STo2																																								
0	0	1	STi3 / STo3																																								
0	1	0	STi4 / STo4																																								
0	1	1	STi5 / STo5																																								
1	0	0	STi6 / STo6																																								
1	0	1	STi7 / STo7																																								
1	1	0	STi8 / STo8																																								
1	1	1	STi9 / STo9																																								

			7	6	5	4	3	2	1	0
			X	X	SPA2	SPA1	SPA0	SPB2	SPB1	SPB0
Bit	Name	Description								
2-0	SPB2-0	Stream Pair B selection. These three bits define which pair of streams are going to be connected to the switch matrix, together with the permanently connected streams STi0-1 / STo0-1.								
		<u>SPB2</u>	<u>SPB1</u>	<u>SPB0</u>	<u>Stream Pair B Connected</u>					
		0	0	0	STi2 / STo2					
		0	0	1	STi3 / STo3					
		0	1	0	STi4 / STo4					
		0	1	1	STi5 / STo5					
		1	0	0	STi6 / STo6					
		1	0	1	STi7 / STo7					
		1	1	0	STi8 / STo8					
		1	1	1	STi9 / STo9					
These bits are only used when the Switching Configuration bits enable stream pair selection capability (SCB 1-0 =10) and the Input Data Rate Selection bits enable 2 Mb/s operation (IDR-0 = 00). In all other modes, the contents of this register are ignored.										

Figure 7 - Stream Pair Selection (SPS) Register

x=Don't care

Frame Input Offset Register - Read/Write

			7	6	5	4	3	2	1	0
			OFB2	OFB1	OFB0	X	X	X	X	X
Bit	Name	Description								
7-5	OFB2-0	Offset Bits 2-0. These three bits define the time it takes the Serial Interface receiver to recognize and store the first bit of the serial input streams; i.e., to start assuming a new internal frame. The input frame offset can be selected to be up to 4 CK clock periods from the time when frame pulse input signal is applied to the FR input.								
		<u>OFB2</u>	<u>OFB1</u>	<u>OFB0</u>	<u>Number of Clock Periods</u>					
		0	0	0	Normal Operation. No bit offsetting.					
		0	0	1	1					
		0	1	0	2					
		0	1	1	3					
		1	0	0	4					
		1	0	1	Reserved					
		1	1	0	Reserved					
		1	1	1	Reserved					
If frame input offset operation is not required, this register should be cleared by the CPU during system initialization.										

Figure 8 - Frame Input Offset (FIO) Register

Applications

Switch Matrix Architectures

The MT89L86 is an ideal device for designs of medium size switch matrix. For applications where voice and grouped data channels are transported within the same frame, the voice samples have to be time interchanged with a minimum delay while maintaining the integrity of grouped data. To guarantee the integrity of grouped data during switching and to provide a minimum delay for voice connections, the MT89L86 provides the per-channel selection between variable and constant throughput delay. This can be selected by the V/C bit of the Connection Memory High locations.

Different configurations at different data rates can be built to accommodate Non-Blocking matrices of up to 512 channels while maintaining the per channel selection of the device's throughput delay. Some examples of such Non-Blocking configurations are given in Figures 9 to 11.

For applications where voice and data samples are encoded into individual 64 kb/s time-slots on an 8kHz frame basis, the switch matrix can operate with time interchange procedures where only variable throughput delay is guaranteed. For such applications, the MT89L86 allows cost effective implementations of Non-Blocking matrices ranging up to 1024 channels. Figures 12 and 13 show the block diagram of implementations with Non-Blocking capacities of 512 and 1024-channel, respectively.

x=Don't care

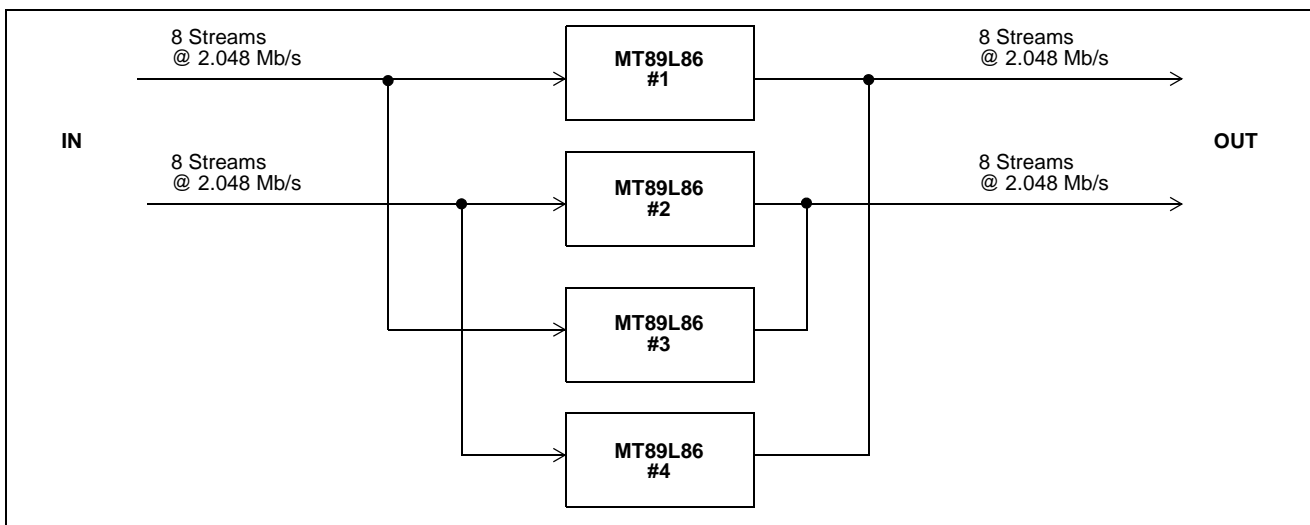

Figure 9 - 512-Channel Switch with Serial Streams at 2.048 Mb/s

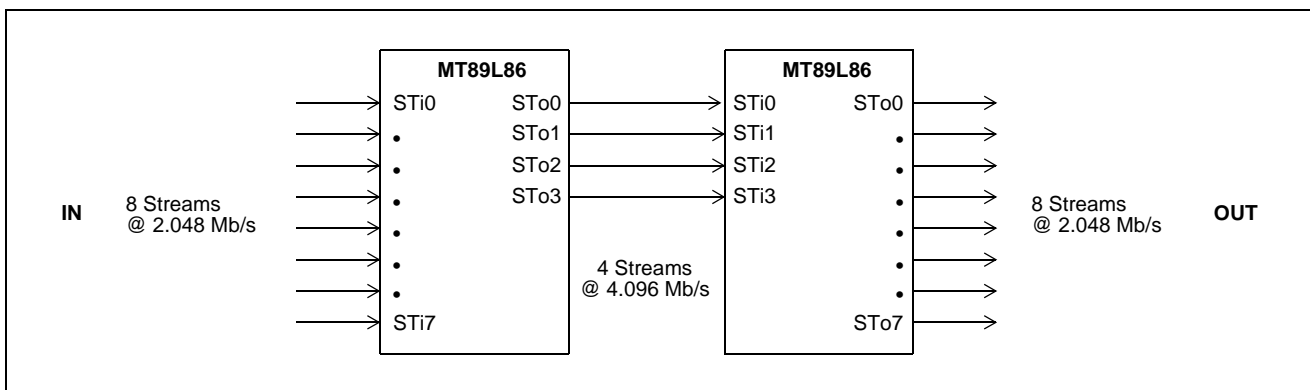

Figure 10 - 256-Channel Switch with Rate Conversion between 2.048 and 4.096 Mb/s

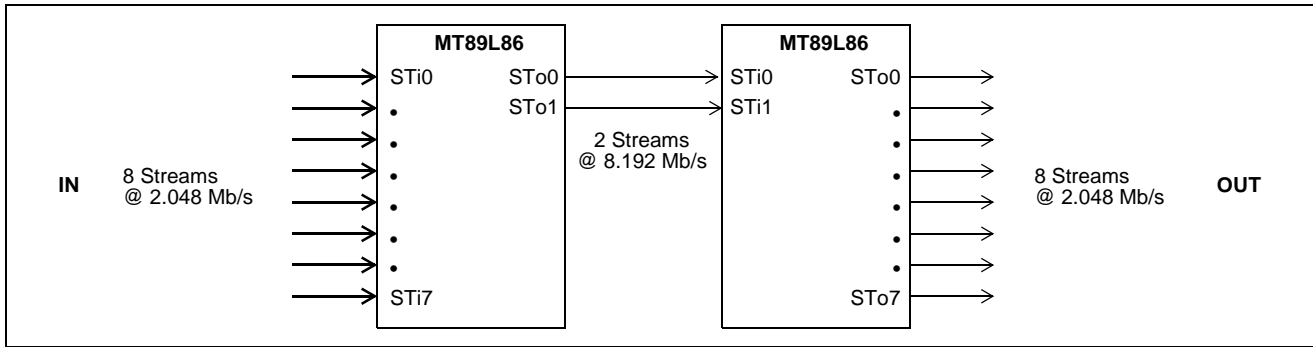

Figure 11 - 256-Channel Switch with Rate Conversion between 2.048 and 8.192 Mb/s

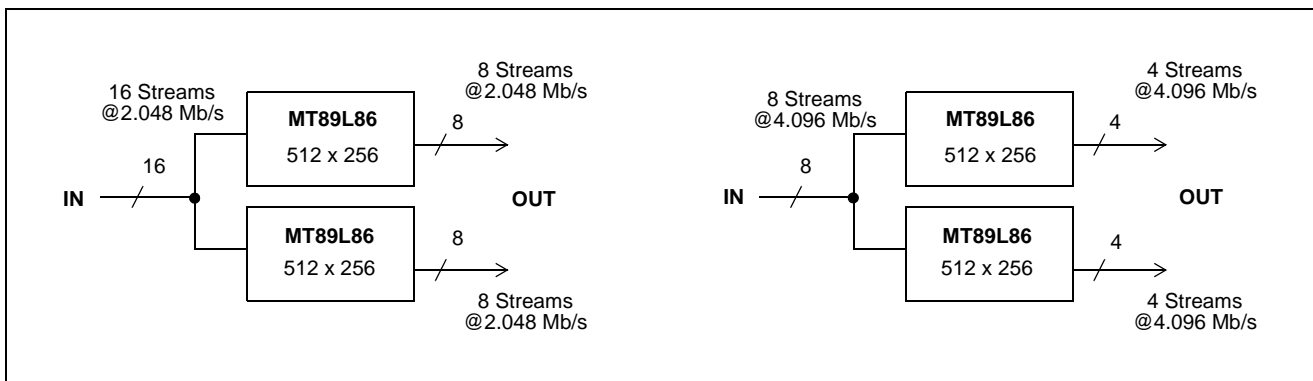

Figure 12 - 512-Channel Non-Blocking Switch Matrix with Serial Streams at 2.048 or 4.096 Mb/s

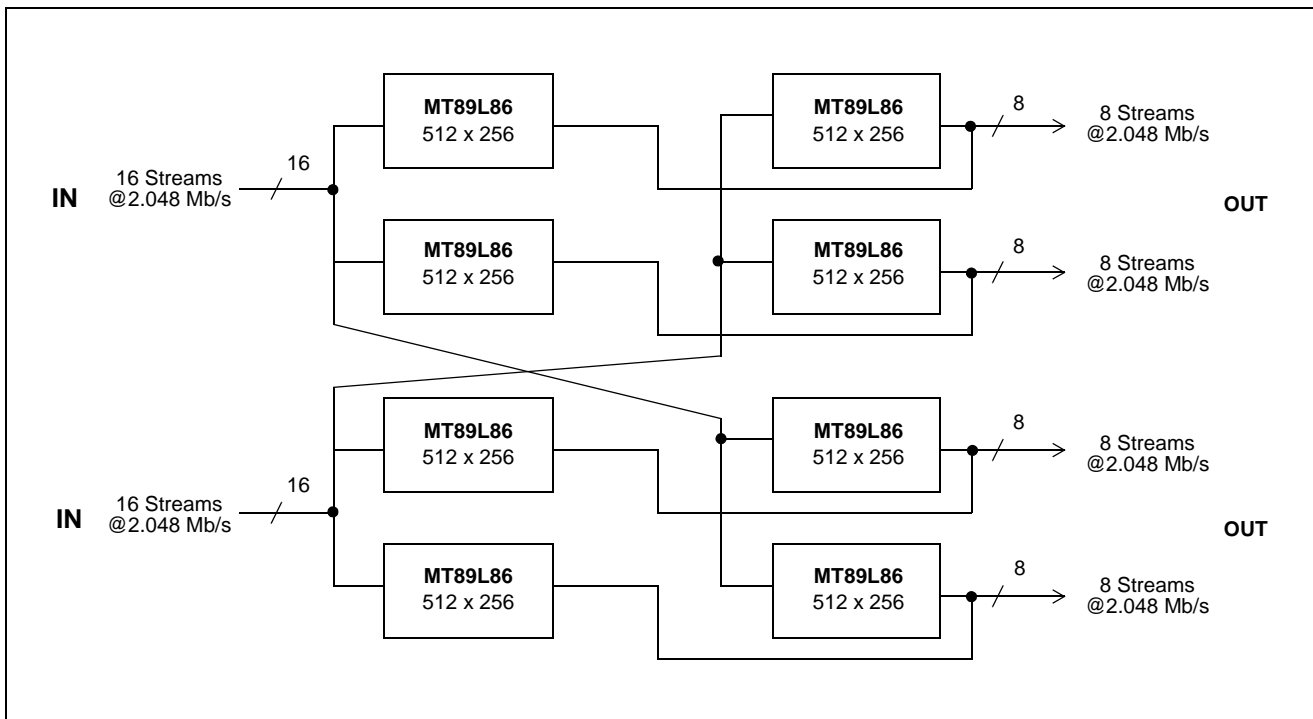

Figure 13 - 1024-Channel Non-Blocking Switch Matrix with Serial Streams at 2.048 Mb/s

Interfacing the MT89L86 with 8051

The Intel 8051 is a very cost effective solution for many applications that do not require a large CPU interaction and processing overhead. However, in applications where 8051 is connected to peripherals operating on a synchronous 8 kHz time-base like the MT89L86, some connectivity issues have to be addressed. The MT89L86 may hold the CPU read/write cycle due to internal contention between the on-chip microprocessor port and the internal serial-to-parallel and parallel-to-serial converters. Since the 8051 family of CPUs do not provide Data Ready type of inputs, some external logic and software intervention have to be provided between the MT89L86 and the 8051 microcontroller to allow read/write operations. The external logic described in Figure 14 is a block diagram of a logical connection between the MT89L86 and 8051. Its main function is to store the 8051 data during a write and the MT89L86 data during a read.

For a write, address is latched by the MT89L86's internal address latch on the falling edge of the ALE input. Whenever a read or write operation is done to the MT89L86, the address decoded signal (\overline{MTA}) is used to latch the state of \overline{RD} , \overline{WR} , and the ALE signals, until the data acknowledge output signal is provided by the MT89L86, releasing the latches for a new read/write cycle. Latch U5 is used to hold the 8051 data for a write until the CPU is ready to accept it (when \overline{DTA} goes low). Latch U4 stores the MT89L86 output data during a read cycle whenever \overline{DTA} goes low. When writing to the MT89L86, one write operation is sufficient. However, when reading from the MT89L86, two read operations with the same address are required, with the second being valid.

Absolute Maximum Ratings*

	Parameter	Symbol	Min.	Max.	Units
1	Supply Voltage		-0.3	5.0	V
2	Voltage on any I/O pin (except supply pins)	V_O	$V_{SS}-0.3$	$V_{DD}+0.3$	V
3	Current at Digital Outputs	I_O		20	mA
4	Storage Temperature	T_S	-55	+125	°C
5	Package Power Dissipation	P_D		1	W

* Exceeding these values may cause permanent damage. Functional operation under these conditions is not implied.

Recommended Operating Conditions - Voltages are with respect to ground (V_{SS}) unless otherwise stated.

	Characteristics	Sym.	Min.	Typ.†	Max.	Units	Test Conditions
1	Operating Temperature	T_{OP}	-40	25	+85	°C	
2	Positive Supply	V_{DD}	3.0	3.3	3.6	V	
3	Input High Voltage	V_{IH}	$0.7V_{DD}$		V_{DD}	V	
4	Input High Voltage on 5 V Tolerant Inputs	V_{IH}			5.5	V	
5	Input Low Voltage	V_{IL}	V_{SS}		$0.3V_{DD}$	V	

† Typical figures are at 25°C and are for design aid only; not guaranteed and not subject to production testing.

DC Electrical Characteristics - Voltages are with respect to ground (V_{SS}) unless otherwise stated.

		Characteristics	Sym.	Min.	Typ.†	Max.	Units	Test Conditions
1	I N P U T S	Supply Current	I_{DD}		6	10	mA	Outputs unloaded
2		Input High Voltage	V_{IH}	$0.7V_{DD}$			V	
3		Input Low Voltage	V_{IL}			$0.3V_{DD}$	V	
4		Input Leakage	I_{IL}			5	μA	V_I between V_{SS} and V_{DD}
5		Input Pin Capacitance	C_I			10	pF	
6	O U T P U T S	Output High Voltage	V_{OH}	$0.8V_{DD}$			V	$I_{OH} = 10$ mA
7		Output High Current	I_{OH}	10			mA	Sourcing. $V_{OH}=2.4$ V
8		Output Low Voltage	V_{OL}			0.4	V	$I_{OL} = 5$ mA
9		Output Low Current	I_{OL}	5			mA	Sinking. $V_{OL} = 0.4$ V
10		High Impedance Leakage	I_{OZ}			5	μA	V_O between V_{SS} and V_{DD}
11		Output Pin Capacitance	C_O			10	pF	

† Typical figures are at 25°C and are for design aid only; not guaranteed and not subject to production testing.

AC Electrical Characteristics –Timing Parameter Measurement Voltage Levels

	Characteristics	Sym.	Level	Units	Test Conditions
1	CMOS Threshold Voltage	V_{TT}	$0.5V_{DD}$	V	
2	CMOS Rise/Fall Threshold Voltage high	V_{HM}	$0.7V_{DD}$	V	
3	CMOS Rise/Fall Threshold Voltage low	V_{LM}	$0.3V_{DD}$	V	

AC Electrical Characteristics† – ST-BUS Timing (2.048 Mb/s)

Voltages are with respect to ground (VSS) unless otherwise stated.

	Characteristics	Sym.	Min.	Typ.‡	Max.	Units	Test Conditions
1	Frame Pulse width	t_{FRW}		244		ns	
2	Frame Pulse setup time	t_{FRS}	10		190	ns	
3	Frame Pulse hold time	t_{FRH}	20		190	ns	
4	STo delay Active to Active	t_{DAA}			55	ns	$C_L=150$ pF
5	STi setup time	t_{STIS}	20			ns	
6	STi hold time	t_{STIH}	20			ns	
7	Clock period	t_{CLK}	200	244	300	ns	
8	CK Input Low	t_{CL}	85	122	150	ns	
9	CK Input High	t_{CH}	85	122	150	ns	
10	Clock Rise/Fall Time	t_r, t_f			10	ns	

† Timing is over recommended temperature & power supply voltages ($V_{DD}=3$ V±5%, $V_{SS}=0$ V, $T_A=-40$ to 85°C).

‡ Typical figures are at 25°C and are for design aid only: not guaranteed and not subject to production testing.

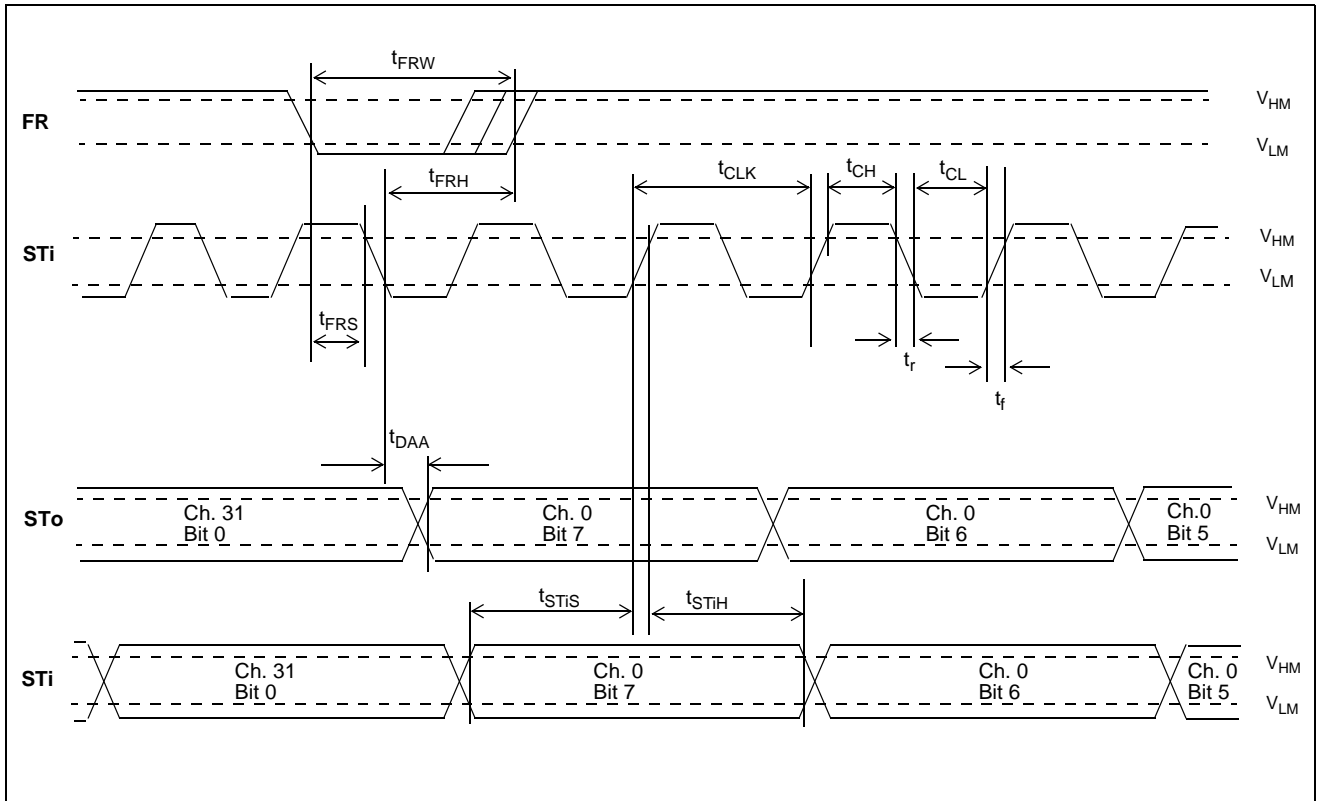

Figure 15 - ST-BUS Timing (CLKM bit=0)

AC Electrical Characteristics[†] - GCI Timing (2.048 Mb/s)

Voltages are with respect to ground (VSS) unless otherwise stated.

	Characteristics	Sym.	Min.	Typ. [‡]	Max.	Units	Test Conditions
1	Clock Period	t_{CK}	150	244	300	ns	
2	Pulse Width	t_{CL}, t_{CH}	73	122	150	ns	
3	Frame Width High	t_{WFH}		244		ns	
4	Frame Setup	t_{FRS}	10		190	ns	
5	Frame Hold	t_{FRH}	20		190	ns	
6	Data Delay/Clock Active to Active	t_{DAA}			55	ns	$C_L=150$ pF
7	Serial Input Setup	t_{STIS}	20			ns	
8	Serial Input Hold	t_{STIH}	20			ns	
9	Clock Rise/Fall Time	t_r, t_f			10	ns	

[†] Timing is over recommended temperature & power supply voltages ($V_{DD}=3$ V \pm 5%, $V_{SS}=0$ V, $T_A=-40$ to 85°C).

[‡] Typical figures are at 25°C and are for design aid only: not guaranteed and not subject to production testing.

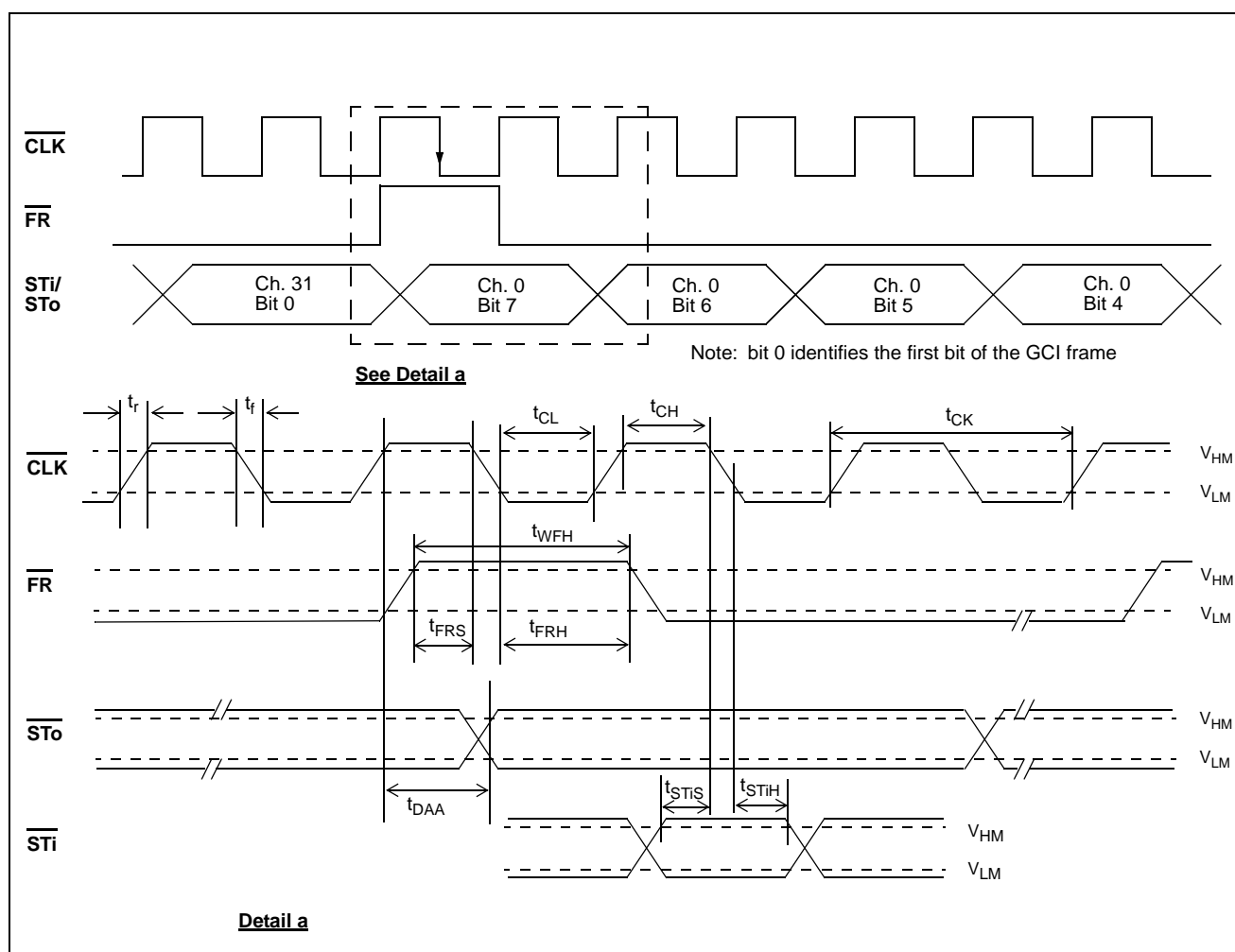

Figure 16 - GCI Timing (CLKM bit=0)

AC Electrical Characteristics[†] - Serial Streams for ST-BUS and GCI Backplanes (2.048 Mb/s)

		Characteristics	Sym.	Min.	Typ. [‡]	Max.	Units	Test Conditions
1	O U T P U T S	STo0/9 Delay - Active to High Z	t_{SAZ}			55	ns	$R_L=1\text{ K}\Omega^*$, $C_L=150\text{ pF}$
2		STo0/9 Delay - High Z to Active	t_{SZA}			55	ns	$C_L=150\text{ pF}$
3		Output Driver Enable Delay	t_{OED}			50	ns	$R_L=1\text{ K}\Omega^*$, $C_L=150\text{ pF}$
4		CSTo Output Delay	t_{XCD}			55	ns	$C_L=150\text{ pF}$

[†] Timing is over recommended temperature & power supply voltages.

[‡] Typical figures are at 25°C and are for design aid only; not guaranteed and not subject to production testing.

* High Impedance is measured by pulling to the appropriate rail with R_L , with timing corrected to cancel time taken to discharge C_L .

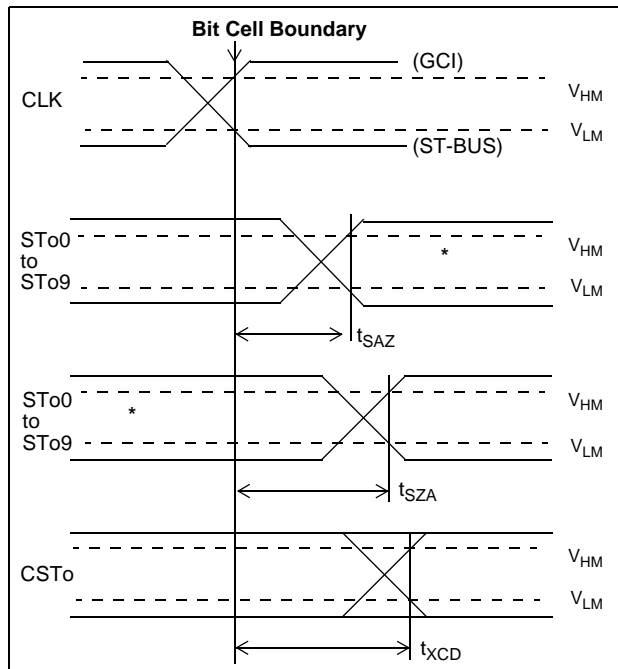

Figure 17 - Serial Outputs and External Control

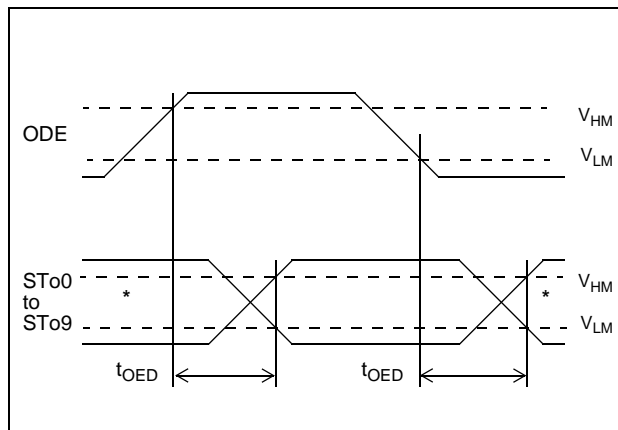

Figure 18 - Output Driver Enable

AC Electrical Characteristics - Serial Streams at 4.096 and 8.192 Mb/s (refer to Figures 19-24)

	Characteristics	Sym.	Min.	Typ.	Max.	Units	Test Conditions
1	Clock Period 4.096 Mb/s 8.192 Mb/s	t_{CK}	190 110	244 122	300 150	ns ns	
2	Clock Pulse High 4.096 Mb/s 8.192 Mb/s	t_{CH}	85 50	122 60	150 70	ns ns	
3	Clock Pulse Low 4.096 Mb/s 8.192 Mb/s	t_{CL}	85 50	122 60	150 70	ns ns	
4	Frame Sync Setup 4.096 Mb/s 8.192 Mb/s	t_{FS}	10 10		190 90	ns ns	
5	Frame Sync Hold 4.096 Mb/s 8.192 Mb/s	t_{FH}	20 20		190 90	ns ns	
6	Frame Sync Width 4.096 Mb/s 8.192 Mb/s	t_{FW}		244 122		ns ns	
7	Valid Data Delay from CK Input 4.096 Mb/s 8.192 Mb/s	t_{DD}			50 45	ns ns	$C_L = 150$ pF $C_L = 150$ pF
8	Input Data Setup	t_{DS}	5			ns	
9	Input Data Hold	t_{DH}	5			ns	
10	STo Delay from Active to High Z	t_{AZ}			50	ns	$C_L = 150$ pF, $R_L = 1$ K Ω^*
11	STo Delay from High Z to Active	t_{ZA}			50	ns	$C_L = 150$ pF
12	Output Drive Enable Delay	t_{OED}			40	ns	$C_L = 50$ pF, $R_L = 1$ K Ω^*

* High Impedance is measured by pulling to the appropriate rail with R_L , with timing corrected to cancel time taken to discharge C_L .

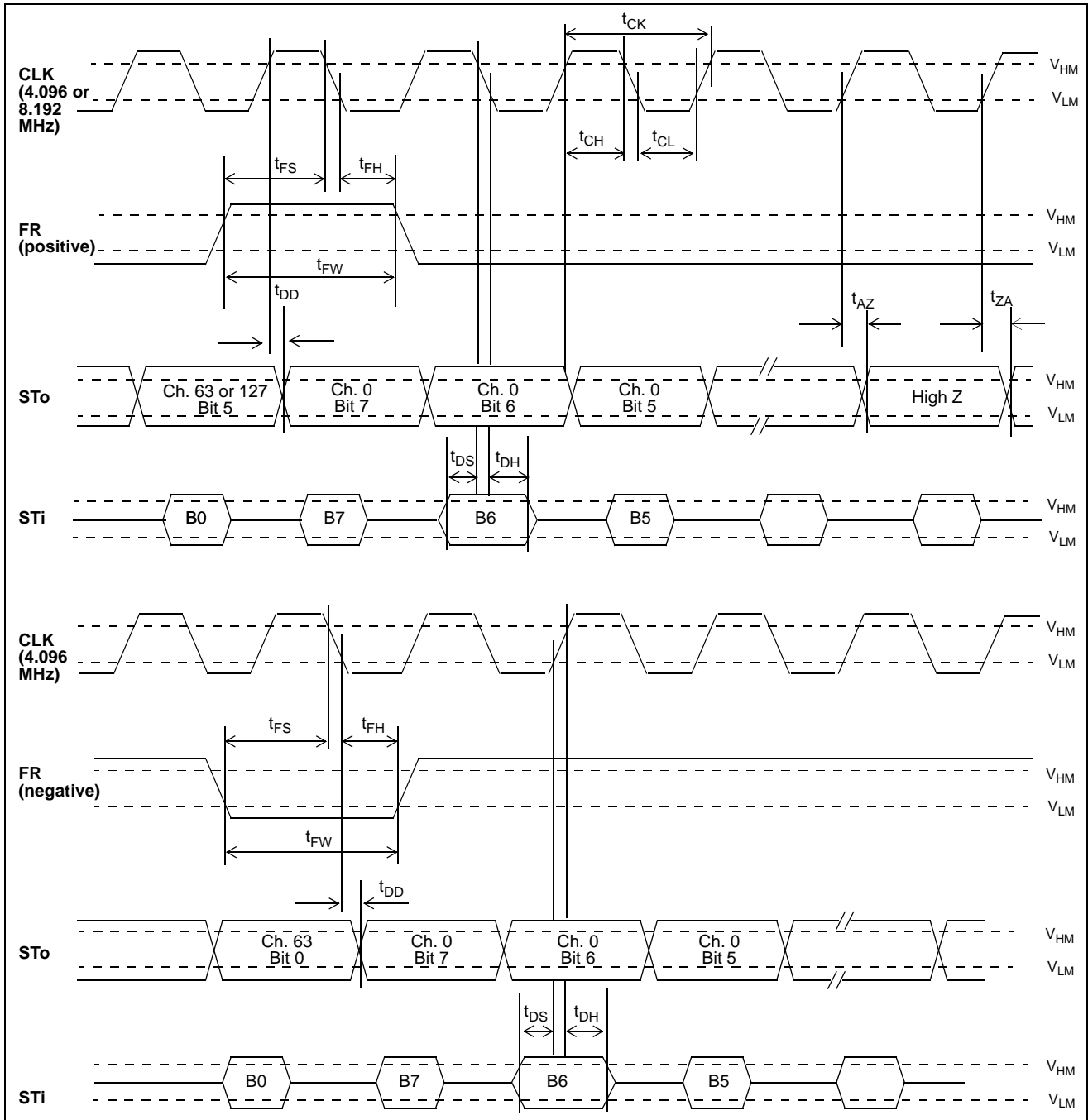

Figure 19 - Serial Interface Timing (CLKM bit=1, DMO bit=0) - 4.096 and 8.192 Mb/s

Note: For 8.192 Mb/s clock, only the positive polarity frame pulse is accepted by the 3.3 V MT89L86.

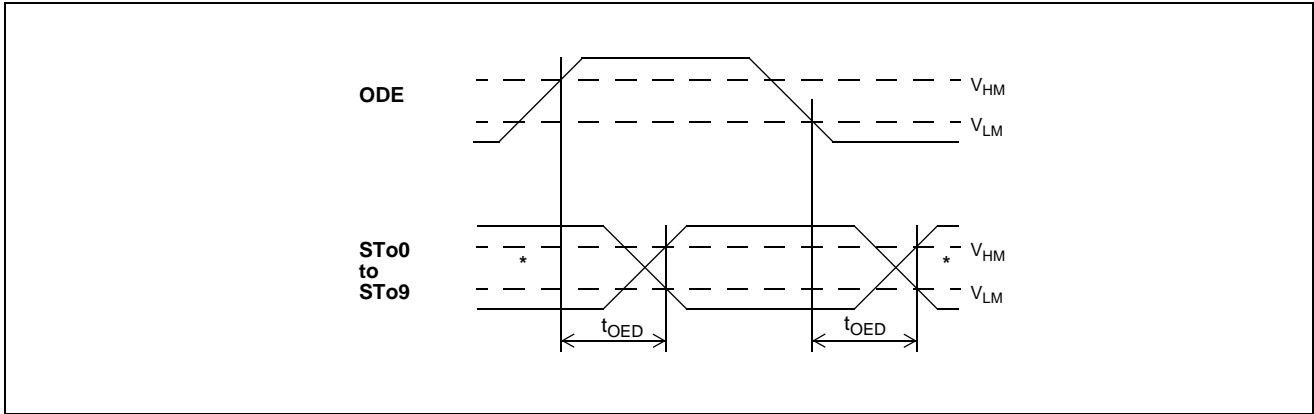

Figure 20 - Output Driver Enable for Streams at 4.096 and 8.192 Mb/s

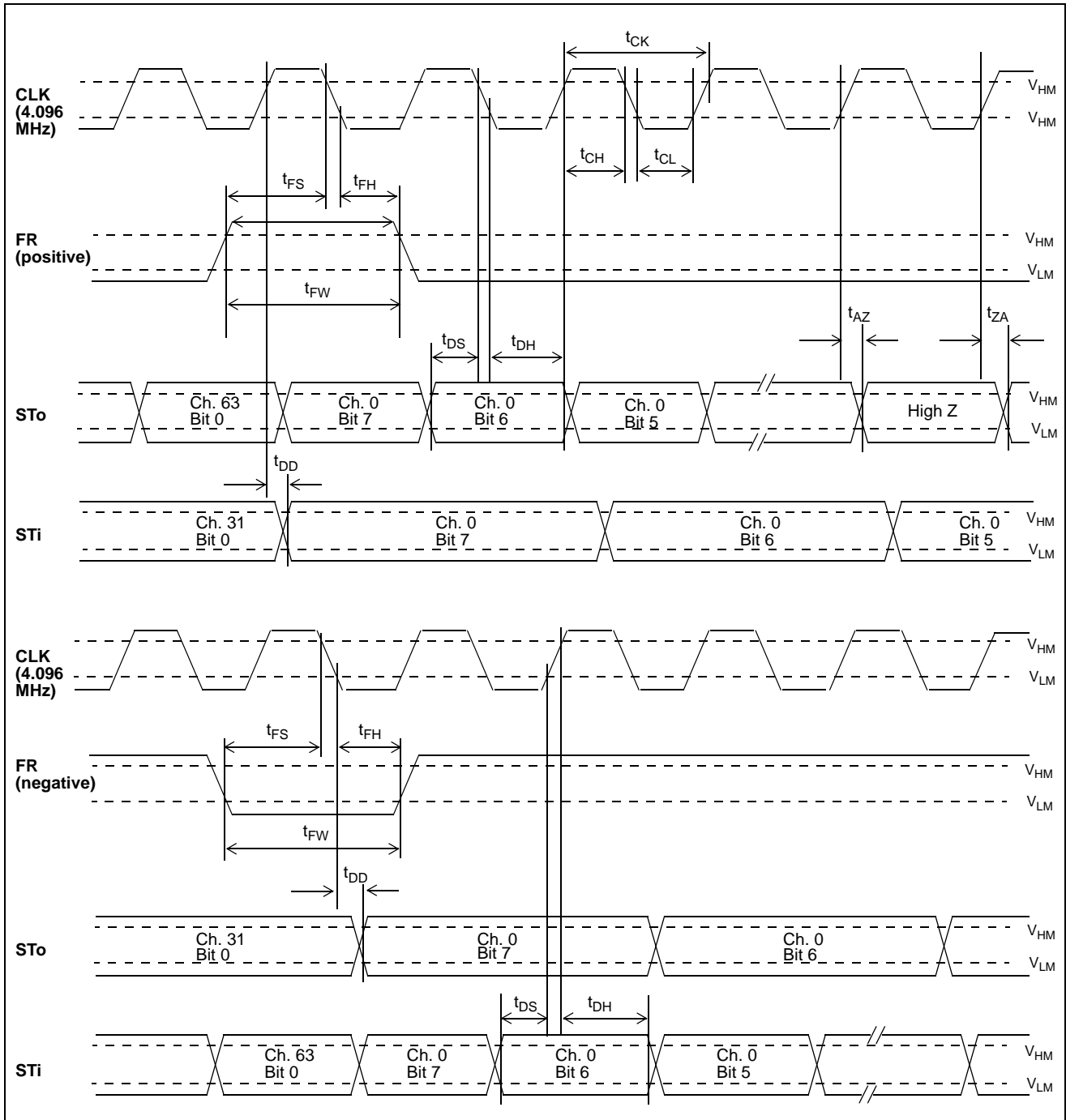

Figure 21 - Rate Conversion Mode (DMO bit=1) - 4 Mb/s to 2 Mb/s

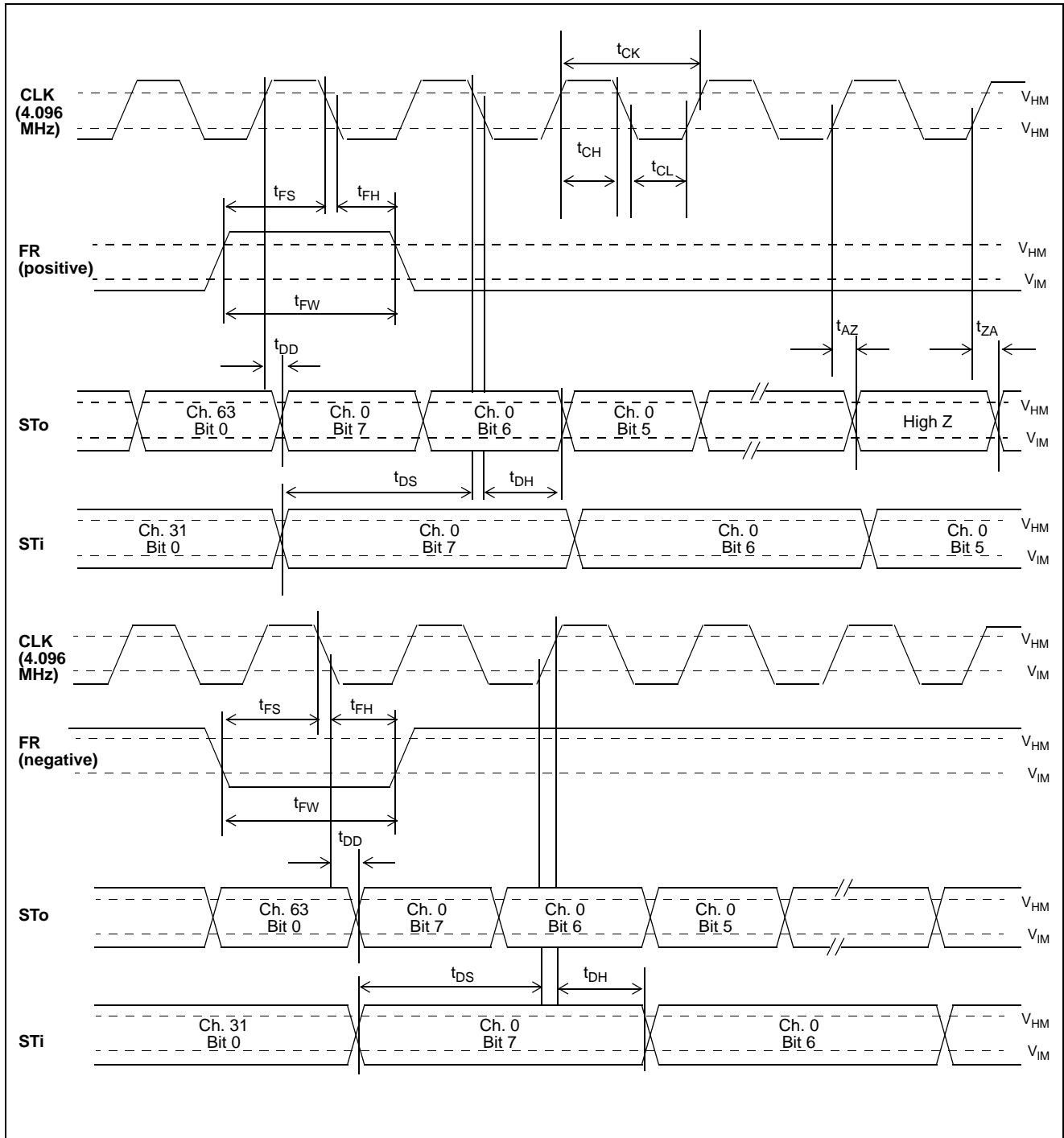

Figure 22 - Rate Conversion Mode (DMO bit=1) - 2 Mb/s to 4 Mb/s

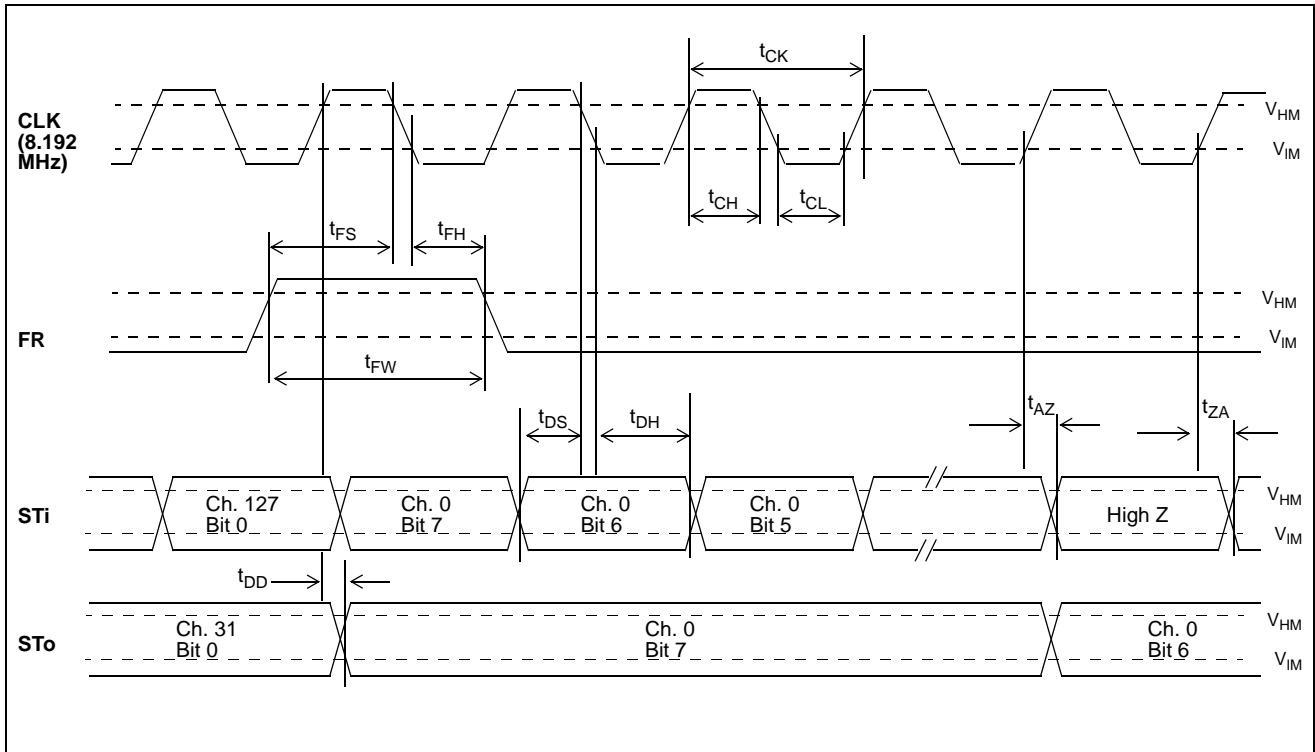

Figure 23 - Rate Conversion Mode (DMO bit=1) - 8 Mb/s to 2 Mb/s

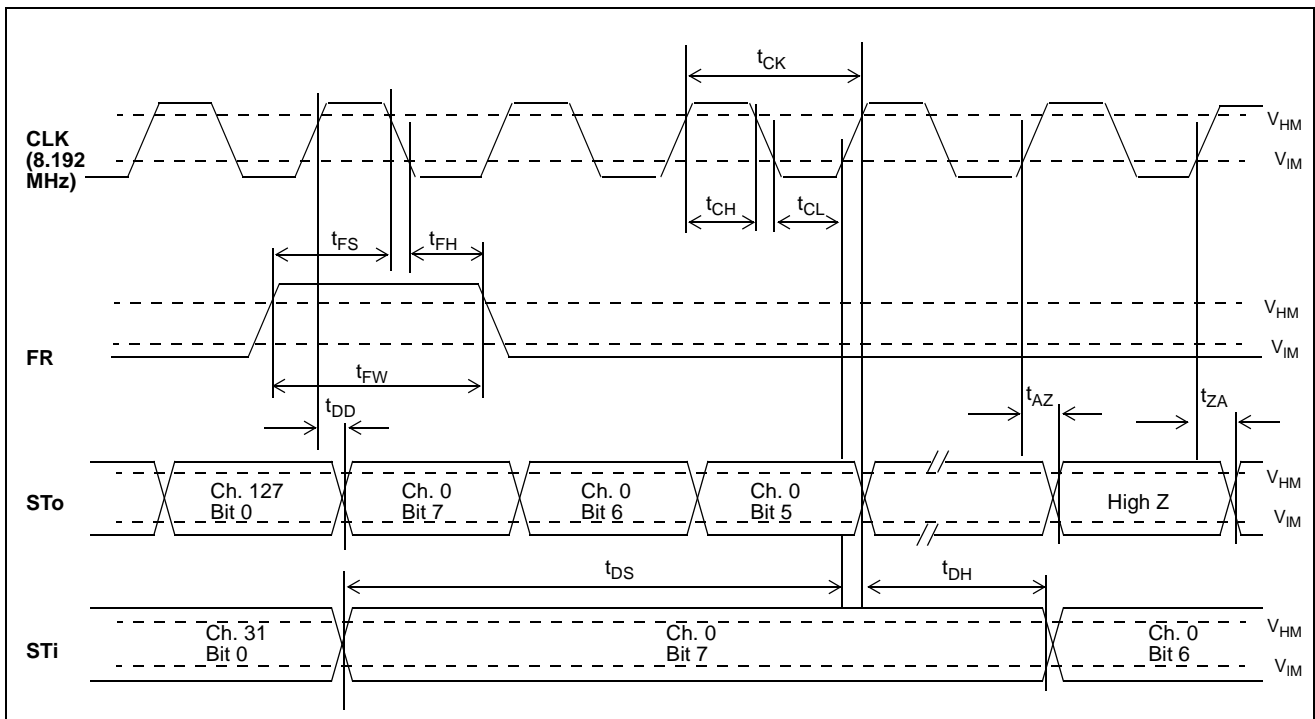

Figure 24 - Rate Conversion Mode (DMO bit=1) - 2 Mb/s to 8 Mb/s

AC Electrical Characteristics[†] - Intel/National- HPC Multiplexed Bus Mode

Voltages are with respect to ground (VSS) unless otherwise stated.

	Characteristics	Sym.	Min.	Typ. [‡]	Max.	Units	Test Conditions
1	ALE pulse width	t_{ALW}	20			ns	
2	Address setup from ALE falling	t_{ADS}	2			ns	
3	Address hold from ALE falling	t_{ADH}	2			ns	
4	\overline{RD} active after ALE falling	t_{ALRD}	10			ns	
5	Data setup from \overline{DTA} Low on Read	t_{DDR}	0			ns	$C_L=150$ pF
6	\overline{CS} hold after $\overline{RD}/\overline{WR}$	t_{CSRW}	0			ns	
7	\overline{RD} pulse width (fast read)	t_{RW}		80		ns	
8	\overline{CS} setup from \overline{RD}	t_{CSR}	0			ns	
9	Data hold after \overline{RD}	t_{DHR}	10	50	90	ns	$C_L=150$ pF, $R_L=1$ K Ω^*
10	\overline{WR} pulse width (fast write)	t_{WW}		90		ns	
11	\overline{WR} delay after ALE falling	t_{ALWR}	10			ns	
12	\overline{CS} setup from \overline{WR}	t_{CSW}	0			ns	
13	Data setup from \overline{WR} (fast write)	t_{DSW}	90			ns	
14	Valid Data Delay on write (slow write)	t_{SWD}			122	ns	
15	Data hold after \overline{WR} inactive	t_{DHW}	5			ns	
16	Acknowledgment Delay: Reading Data Memory Reading/Writing Conn. Memories Writing to Control & Mode Reg. Reading from Control & Mode Reg.	t_{AKD}		560 62/30 25 52	1220 120/53 65 120	ns ns ns ns	$C_L=150$ pF
17	Acknowledgment Hold Time	t_{AKH}		50	80	ns	$C_L=150$ pF, $R_L=1$ K Ω^*

[†] Timing is over recommended temperature & power supply voltages.[‡] Typical figures are at 25°C and are for design aid only; not guaranteed and not subject to production testing.* High Impedance is measured by pulling to the appropriate rail with R_L , with timing corrected to cancel time taken to discharge C_L .

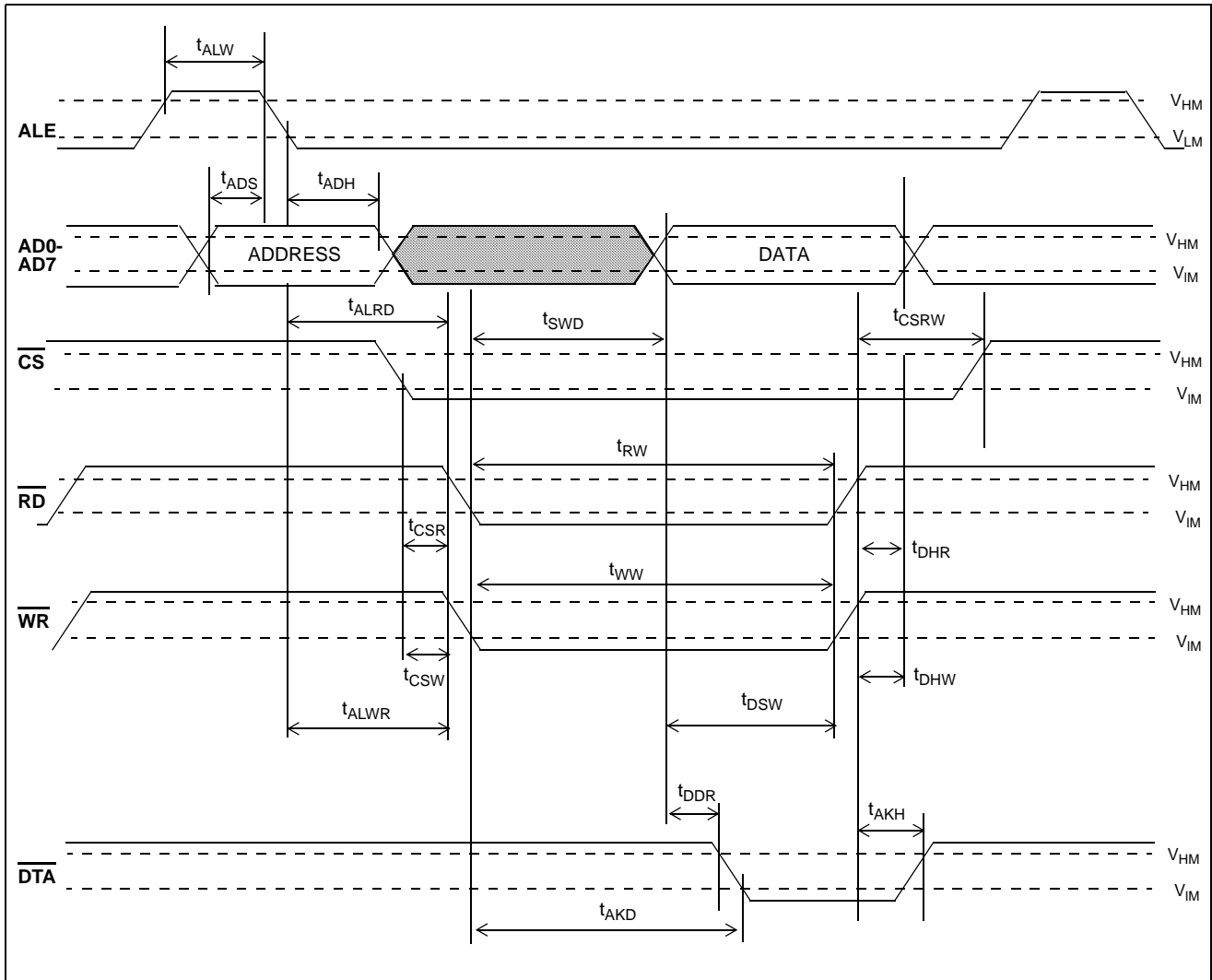

Figure 25 - Intel/National Multiplexed Bus Timing

AC Electrical Characteristics[†] - Motorola Multiplexed Bus Mode

Voltages are with respect to ground (VSS) unless otherwise stated.

	Characteristics	Sym.	Min.	Typ. [‡]	Max.	Units	Test Conditions
1	AS pulse width	t _{ASW}	80			ns	
2	Address setup from AS falling	t _{ADS}	2			ns	
3	Address hold from AS falling	t _{ADH}	2			ns	
4	Data setup from \overline{DTA} Low on Read	t _{DDR}	10			ns	C _L =150 pF
5	\overline{CS} hold after DS falling	t _{CSH}	0			ns	
6	\overline{CS} setup from DS rising	t _{CSS}	0			ns	
7	Data hold after write	t _{DHW}	8			ns	
8	Data setup from DS - write (fast write)	t _{DWS}	25			ns	
9	Valid Data Delay on write (slow write)	t _{SWD}			122	ns	
10	R \overline{W} setup from DS rising	t _{RWS}	60			ns	
11	R \overline{W} hold after DS falling	t _{RWH}	9			ns	
12	Data hold after read	t _{DHR}	10	50	90	ns	C _L =150 pF, R _L =1 K Ω *
13	DS delay after AS falling	t _{DSH}	10			ns	
14	Acknowledgment Delay: Reading Data Memory Reading/Writing Conn. Memories Writing Control & Mode Regs. Reading from Control & Mode Regs.	t _{AKD}		560 62/30 25 52	1220 120/53 65 120	ns ns ns ns	C _L =150 pF
15	Acknowledgment Hold Time	t _{AKH}		50	80	ns	C _L =150 pF, R _L =1 K Ω *

[†] Timing is over recommended temperature & power supply voltages.[‡] Typical figures are at 25°C and are for design aid only; not guaranteed and not subject to production testing.* High Impedance is measured by pulling to the appropriate rail with R_L, with timing corrected to cancel time taken to discharge C_L.

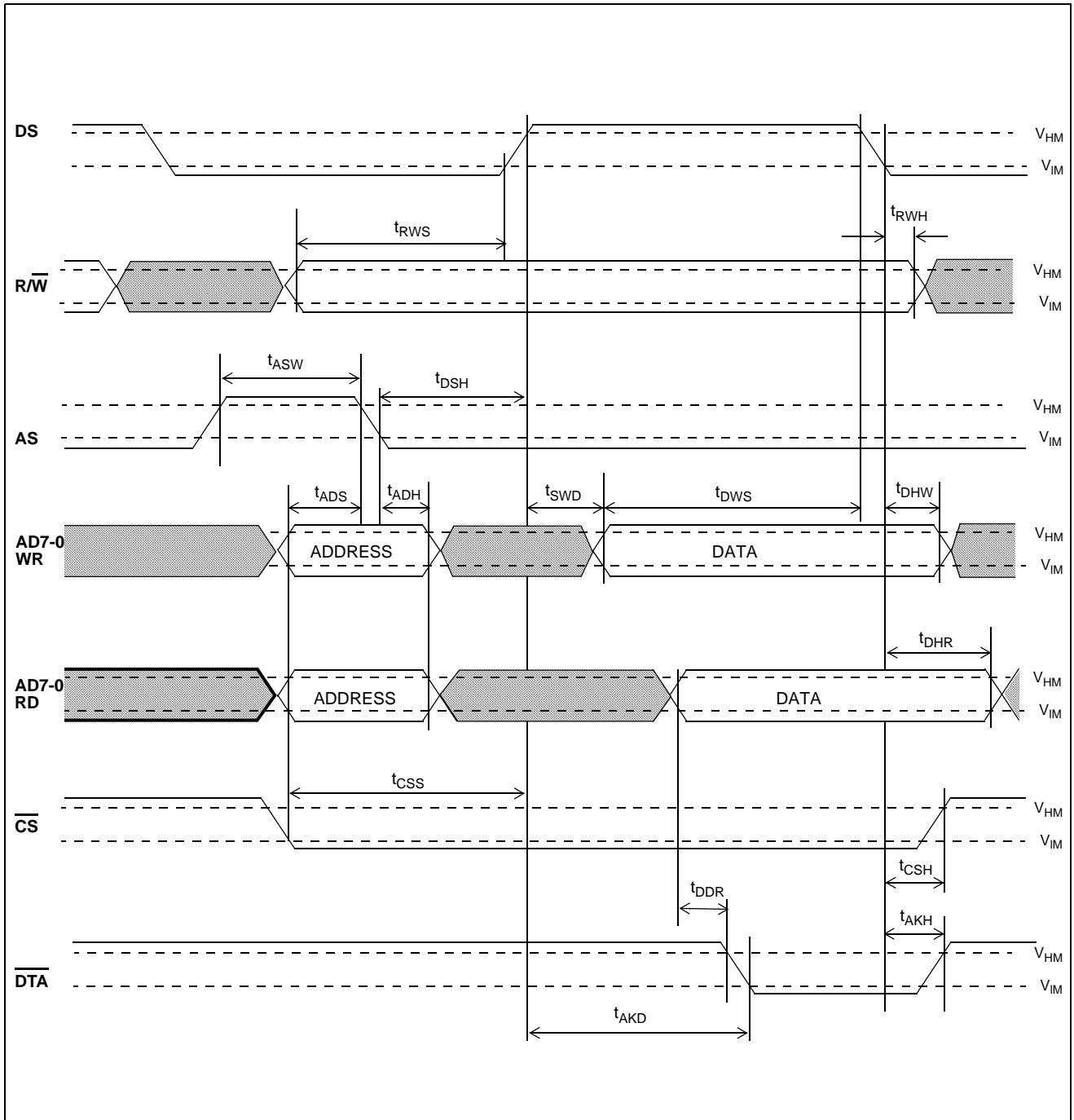

Figure 26 - Motorola Multiplexed Bus Timing

AC Electrical Characteristics[†] - Motorola Non-Multiplexed Bus Mode

Voltages are with respect to ground (VSS) unless otherwise stated.

	Characteristics	Sym.	Min.	Typ. [‡]	Max.	Units	Test Conditions
1	\overline{CS} Setup from DS rising	t_{CSS}	0			ns	
2	R/\overline{W} Setup from DS rising	t_{RWS}	5			ns	
3	Add setup from DS rising	t_{ADS}	5			ns	
4	\overline{CS} hold after DS falling	t_{CSH}	0			ns	
5	R/\overline{W} hold after DS falling	t_{RWH}	5			ns	
6	Add hold after DS falling	t_{ADH}	8			ns	
7	Data setup from \overline{DTA} Low on Read	t_{DDR}	0			ns	$C_L=150$ pF
8	Data hold on read	t_{DHR}	10	50	90	ns	$C_L=150$ pF, $R_L=1$ K Ω *
9	Data setup on write (fast write)	t_{DSW}	0			ns	
10	Valid Data Delay on write (slow write)	t_{SWD}			122	ns	
11	Data hold on write	t_{DHW}	5			ns	
12	Acknowledgment Delay: Reading Data Memory Reading/Writing Conn. Memories Writing Control & Mode Regs. Reading from Control & Mode Regs.	t_{AKD}		560 62/30 25 52	1220 120/53 65 120	ns ns ns ns	$C_L=150$ pF
13	Acknowledgment Hold Time	t_{AKH}		50	80	ns	$C_L=150$ pF, $R_L=1$ K Ω *

[†] Timing is over recommended temperature & power supply voltages.

[‡] Typical figures are at 25°C and are for design aid only: not guaranteed and not subject to production testing.

* High Impedance is measured by pulling to the appropriate rail with R_L , with timing corrected to cancel time taken to discharge C_L .

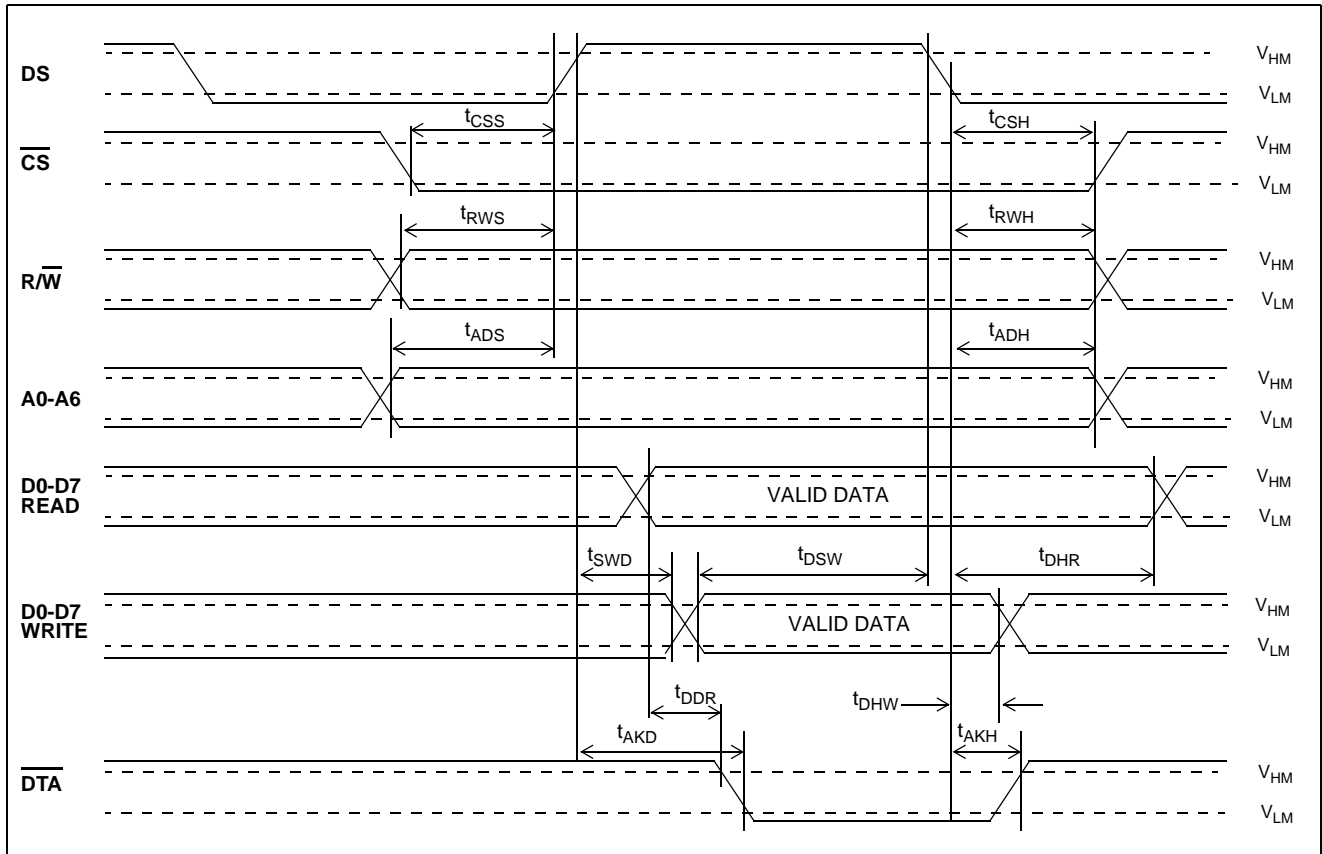
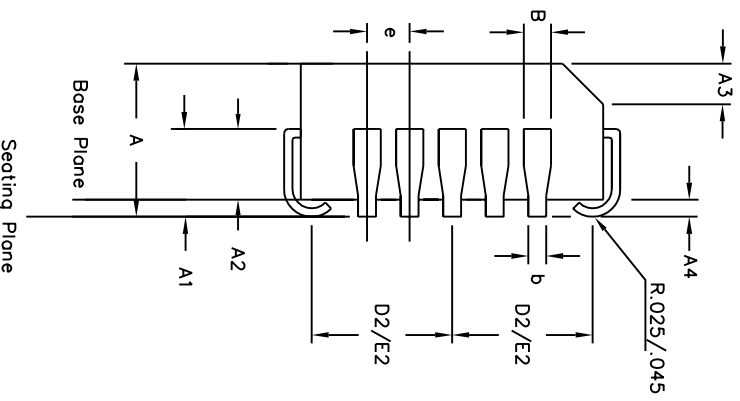
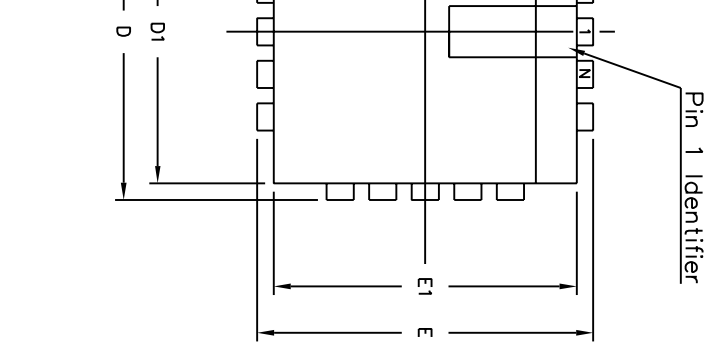

Figure 27 - Motorola Non-Multiplexed Bus Timing



Symbol	Control Dimensions in. inches		Altern. Dimensions in. millimetres	
	MIN	MAX	MIN	MAX
A	0.165	0.180	4.19	4.57
A1	0.090	0.120	2.29	3.05
A2	0.062	0.083	1.57	2.11
A3	0.042	0.056	1.07	1.42
A4	0.020	—	0.51	—
D	0.685	0.695	17.40	17.65
D1	0.650	0.656	16.51	16.66
D2	0.291	0.319	7.39	8.10
E	0.685	0.695	17.40	17.65
E1	0.650	0.656	16.51	16.66
E2	0.291	0.319	7.39	8.10
B	0.026	0.032	0.66	0.81
b	0.013	0.021	0.33	0.53
e	0.050	BSC	1.27	BSC
Pin features				
ND	11			
NE	11			
N	44			
Note	Square			
Conforms to JEDEC MS-018AC Iss. A				

ances conform to ANSI Y14.5M-1982
do not include mould protrusions.
on is 0.010" per side. Dimensions D1 and E1
mismatch and are determined at the
and E1 are measured at the extreme material
r lower parting line.
r inches.
rmminals.
120° minimum bend.



Previous package codes

HP / P

Package Code QA

Package Outline for
44 lead PLCC

GPD000003

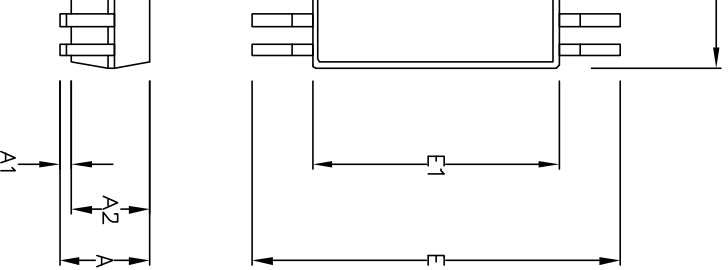
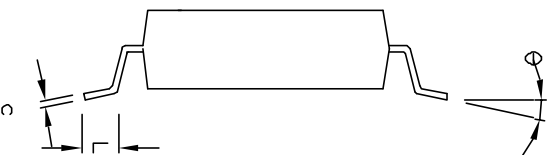

Symbol	Control Dimensions in millimetres			Altern. Dimensions in inches		
	MIN	Nominal	MAX	MIN	Nominal	MAX
A	2.41	2.59	2.79	0.095	0.102	0.110
A1	0.20	0.30	0.40	0.008	0.012	0.016
A2	2.26	2.39	2.52	0.089	0.094	0.099
D	15.75	15.88	16.00	0.620	0.625	0.630
E	10.03	10.31	10.67	0.395	0.406	0.420
E1	7.39	7.49	7.59	0.291	0.295	0.299
L	0.51	0.76	1.02	0.020	0.030	0.040
e	0.64 BSC.			0.025 BSC.		
b	0.20	0.25	0.34	0.008	0.010	0.0135
c	0.13	0.20	0.25	0.005	0.008	0.010
θ	0°		8°	0°		8°
Pin features						
48						
N						
Conforms to JEDEC MO-118 AA Iss. A						

a dot, must be located within the cross-hatched area.
 n millimeters.
 ot include mould flash or protrusion. Mould flash or protrusion shall not exceed
 E1 are maximum plastic body size dimensions including mould mismatch.



Previous package codes	Package Code	Package Outline for 48 lead SSOP (300 mil Body Width)
NP / N	DD	
		GPD00816



**For more information about all Zarlink products
visit our Web Site at
www.zarlink.com**

Information relating to products and services furnished herein by Zarlink Semiconductor Inc. or its subsidiaries (collectively "Zarlink") is believed to be reliable. However, Zarlink assumes no liability for errors that may appear in this publication, or for liability otherwise arising from the application or use of any such information, product or service or for any infringement of patents or other intellectual property rights owned by third parties which may result from such application or use. Neither the supply of such information or purchase of product or service conveys any license, either express or implied, under patents or other intellectual property rights owned by Zarlink or licensed from third parties by Zarlink, whatsoever. Purchasers of products are also hereby notified that the use of product in certain ways or in combination with Zarlink, or non-Zarlink furnished goods or services may infringe patents or other intellectual property rights owned by Zarlink.

This publication is issued to provide information only and (unless agreed by Zarlink in writing) may not be used, applied or reproduced for any purpose nor form part of any order or contract nor to be regarded as a representation relating to the products or services concerned. The products, their specifications, services and other information appearing in this publication are subject to change by Zarlink without notice. No warranty or guarantee express or implied is made regarding the capability, performance or suitability of any product or service. Information concerning possible methods of use is provided as a guide only and does not constitute any guarantee that such methods of use will be satisfactory in a specific piece of equipment. It is the user's responsibility to fully determine the performance and suitability of any equipment using such information and to ensure that any publication or data used is up to date and has not been superseded. Manufacturing does not necessarily include testing of all functions or parameters. These products are not suitable for use in any medical products whose failure to perform may result in significant injury or death to the user. All products and materials are sold and services provided subject to Zarlink's conditions of sale which are available on request.

Purchase of Zarlink's I2C components conveys a license under the Philips I2C Patent rights to use these components in an I2C System, provided that the system conforms to the I2C Standard Specification as defined by Philips.

Zarlink, ZL, the Zarlink Semiconductor logo and the Legerity logo and combinations thereof, VoiceEdge, VoicePort, SLAC, ISLIC, ISLAC and VoicePath are trademarks of Zarlink Semiconductor Inc.

TECHNICAL DOCUMENTATION - NOT FOR RESALE

Looking for pricing, stock, or lifecycle information?

Click below to explore more details on WIN SOURCE:

- ⊖ [View MT89L86ANR on WIN SOURCE](#)
- ⊖ [Microsemi Corporation Information](#)

Optimize Your Supply Chain with WIN SOURCE Solutions

- ✓ Global Sourcing Solution
- ✓ Obsolete Management
- ✓ Cost Control Management
- ✓ Shortage Management
- ✓ Alternative Solution
- ✓ Excess Inventory Management