



**THE DATASHEET OF  
MT8980DPR1**



**Features**

April 2011

- Zarlink ST-BUS compatible
- 8-line x 32-channel inputs
- 8-line x 32-channel outputs
- 256 ports non-blocking switch
- Single power supply (+5 V)
- Low power consumption: 30 mW Typ.
- Microprocessor-control interface
- Three-state serial outputs

**Ordering Information**

MT8980DP1	44 Pin PLCC*	Tubes
MT8980DE1	40 Pin PDIP*	Tubes
MT8980DPR1	44 Pin PLCC*	Tape & Reel

**\*Pb Free Matte Tin**  
**-40°C to +85°C**

**Description**

This VLSI ISO-CMOS device is designed for switching PCM-encoded voice or data, under microprocessor control, in a modern digital exchange, PBX or Central Office. It provides simultaneous connections for up to 256 64 kbit/s channels. Each of the eight serial inputs and outputs consist of 32 64 kbit/s channels multiplexed to form a 2048 kbit/s ST-BUS stream. In addition, the MT8980 provides microprocessor read and write access to individual ST-BUS channels.

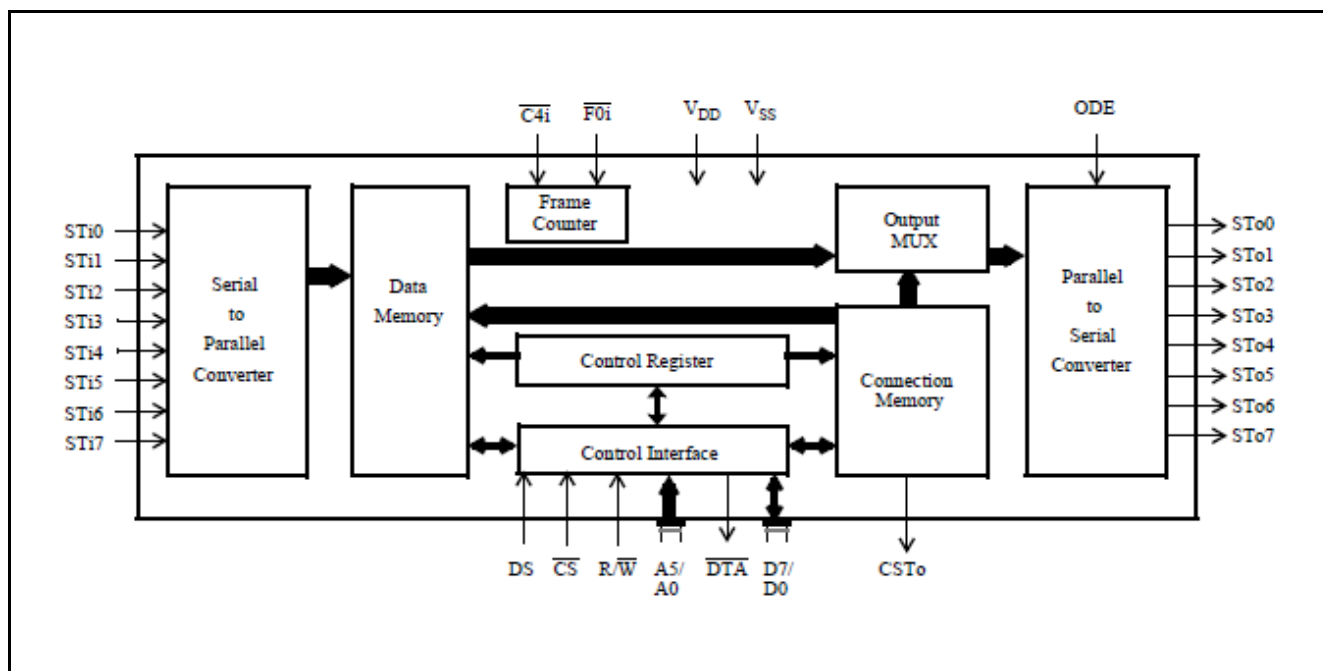
**Figure 1 - Functional Block Diagram**

**Change Summary**

Changes from February 2005 Issue to April 2011 Issue.

Page	Item	Change
1	Ordering Information	Obsolete Leaded packages, only Pb Free packages are available.

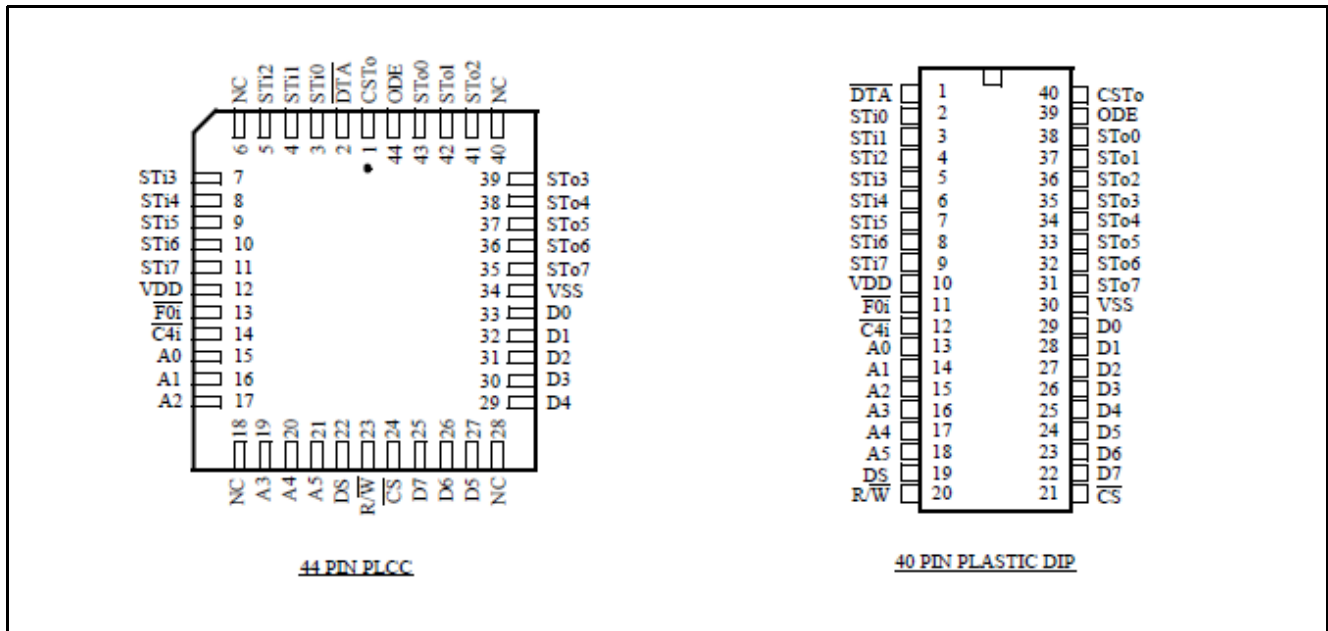

**Figure 2 - Pin Connections**

**Pin Description**

Pin #		Name	Description
40 DIP	44 PLCC		
1	2	DTA	<b>Data Acknowledgement (Open Drain Output).</b> This is the data acknowledgement on the microprocessor interface. This pin is pulled low to signal that the chip has processed the data. A 909 Ω 1/4W, resistor is recommended to be used as a pullup.
2-4	3-5	STIo0-STIo2	<b>ST-BUS Input 0 to 2 (Inputs).</b> These are the inputs for the 2048 kbit/s ST-BUS input streams.
5-9	7-11	STIo3-STIo7	<b>ST-BUS Input 3 to 7 (Inputs).</b> These are the inputs for the 2048 kbit/s ST-BUS input streams.
10	12	V <sub>DD</sub>	<b>Power Input.</b> Positive Supply.
11	13	FOi	<b>Framing 0-Type (Input).</b> This is the input for the frame synchronization pulse for the 2048 kbit/s ST-BUS streams. A low on this input causes the internal counter to reset on the next negative transition of C4i.

## Pin Descripton

Pin #		Name	Description
40 DIP	44 PLCC		
12	14	$\overline{C4i}$	<b>4.096 MHz Clock (Input).</b> ST-BUS bit cell boundaries lie on the alternate falling edges of this clock.
13-15	15-17	A0-A2	<b>Address 0 to 2 (Inputs).</b> These are the inputs for the address lines on the microprocessor interface.
16-18	19-21	A3-A5	<b>Address 3 to 5 (Inputs).</b> These are the inputs for the address lines on the microprocessor interface.
19	22	DS	<b>Data Strobe (Input).</b> This is the input for the active high data strobe on the microprocessor interface.
20	23	R/W	<b>Read or Write (Input).</b> This is the input for the read/write signal on the microprocessor interface - high for read, low for write.
21	24	$\overline{CS}$	<b>Chip Select (Input).</b> This is the input for the active low chip select on the microprocessor interface.
22-24	25-27	D7-D5	<b>Data 7 to 5 (Three-state I/O Pins).</b> These are the bidirectional data pins on the microprocessor interface.
25-29	29-33	D4-D0	<b>Data 4 to 0 (Three-state I/O Pins).</b> These are the bidirectional data pins on the microprocessor interface.
30	34	V <sub>SS</sub>	<b>Power Input.</b> Negative Supply (Ground).
31-35	35-39	STo7-STo3	<b>ST-BUS Output 7 to 3 (Three-state Outputs).</b> These are the pins for the eight 2048 kbit/s ST-BUS output streams.
36-38	41-43	STo2-STo0	<b>ST-BUS Output 2 to 0 (Three-state Outputs).</b> These are the pins for the eight 2048 kbit/s ST-BUS output streams.
39	44	ODE	<b>Output Drive Enable (Input).</b> If this input is held high, the STo0-STo7 output drivers function normally. If this input is low, the STo0-STo7 output drivers go into their high impedance state. <b>NB:</b> Even when ODE is high, channels on the STo0-STo7 outputs can go high impedance under software control.
40	1	CSTo	<b>Control ST-BUS Output (Complementary Output).</b> Each frame of 256 bits on this ST-BUS output contains the values of bit 1 in the 256 locations of the Connection Memory High.
	6, 18, 28, 40	NC	No Connection.

## Functional Description

In recent years, there has been a trend in telephony towards digital switching, particularly in association with software control. Simultaneously, there has been a trend in system architectures towards distributed processing or multi-processor systems.

In accordance with these trends, Zarlink has devised the ST-BUS (Serial Telecom Bus). This bus architecture can be used both in software-controlled digital voice and data switching, and for interprocessor communications. The uses in switching and in interprocessor communications are completely integrated to allow for a simple general purpose architecture appropriate for the systems of the future.

The serial streams of the ST-BUS operate continuously at 2048 kbit/s and are arranged in 125  $\mu$ s wide frames which contain 32 8-bit channels. Zarlink manufactures a number of devices which interface to the ST-BUS; a key device being the MT8980 chip.

The MT8980 can switch data from channels on ST-BUS inputs to channels on ST-BUS outputs, and simultaneously allows its controlling microprocessor to read channels on ST-BUS inputs or write to channels on ST-BUS outputs (Message Mode). To the microprocessor, the MT8980 looks like a memory peripheral. The microprocessor can write to the MT8980 to establish switched connections between input ST-BUS channels and output ST-BUS channels, or to transmit messages on output ST-BUS channels. By reading from the MT8980, the microprocessor can receive messages from ST-BUS input channels or check which switched connections have already been established.

By integrating both switching and interprocessor communications, the MT8980 allows systems to use distributed processing and to switch voice or data in an ST-BUS architecture.

### Hardware Description

Serial data at 2048 kbit/s is received at the eight ST-BUS inputs (STi0 to STi7), and serial data is transmitted at the eight ST-BUS outputs (STo0 to STo7). Each serial input accepts 32 channels of digital data, each channel containing an 8-bit word which may represent a PCM-encoded analog/voice sample as provided by a codec (e.g., Zarlink's MT8964).

This serial input word is converted into parallel data and stored in the 256 X 8 Data Memory. Locations in the Data Memory are associated with particular channels on particular ST-BUS input streams. These locations can be read by the microprocessor which controls the chip.

Locations in the Connection Memory, which is split into high and low parts, are associated with particular ST-BUS output streams. When a channel is due to be transmitted on an ST-BUS output, the data for the channel can either be switched from an ST-BUS input or it can originate from the microprocessor. If the data is switched from an input, then the contents of the Connection Memory Low location associated with the output channel is used to address the Data Memory. This Data Memory address corresponds to the channel on the input ST-BUS stream on which the data for switching arrived. If the data for the output channel originates from the microprocessor (Message Mode), then the contents of the Connection Memory Low location associated with the output channel are output directly, and this data is output repetitively on the channel once every frame until the microprocessor intervenes.

The Connection Memory data is received, via the Control Interface, at D7 to D0. The Control Interface also receives address information at A5 to A0 and handles the microprocessor control signals  $\overline{CS}$ ,  $\overline{DTA}$ , R/W and DS. There are two parts to any address in the Data Memory or Connection Memory. The higher order bits come from the Control Register, which may be written to or read from via the Control Interface. The lower order bits come from the address lines directly.

The Control Register also allows the chip to broadcast messages on all ST-BUS outputs (i.e., to put every channel into Message Mode), or to split the memory so that reads are from the Data Memory and writes are to the Connection Memory Low. The Connection Memory High determines whether individual output channels are in Message Mode, and allows individual output channels to go into a high-impedance state, which enables arrays of MT8980s to be constructed. It also controls the CSto pin.

All ST-BUS timing is derived from the two signals  $\overline{C4i}$  and  $\overline{F0i}$ .

A5	A4	A3	A2	A1	A0	HEX ADDRESS	LOCATION
0	X	X	X	X	X	00 - 1F	Control Register *
1	0	0	0	0	0	20	Channel 0 <sup>†</sup>
1	0	0	0	0	1	21	Channel 1 <sup>†</sup>
•	•	•	•	•	•	•	•
•	•	•	•	•	•	•	•
•	•	•	•	•	•	•	•
1	1	1	1	1	1	3F	Channel 31 <sup>†</sup>

\* Writing to the Control Register is the only fast transaction.  
<sup>†</sup> Memory and stream are specified by the contents of the Control Register.

Figure 3 - Address Memory Map

**Software Control**

The address lines on the Control Interface give access to the Control Register directly or, depending on the contents of the Control Register, to the High or Low sections of the Connection Memory or to the Data Memory.

If address line A5 is low, then the Control Register is addressed regardless of the other address lines (see Fig. 3). If A5 is high, then the address lines A4-A0 select the memory location corresponding to channel 0-31 for the memory and stream selected in the Control Register.

The data in the Control Register consists of mode control bits, memory select bits, and stream address bits (see Fig. 4). The memory select bits allow the Connection Memory High or Low or the Data Memory to be chosen, and the stream address bits define one of the ST-BUS input or output streams.

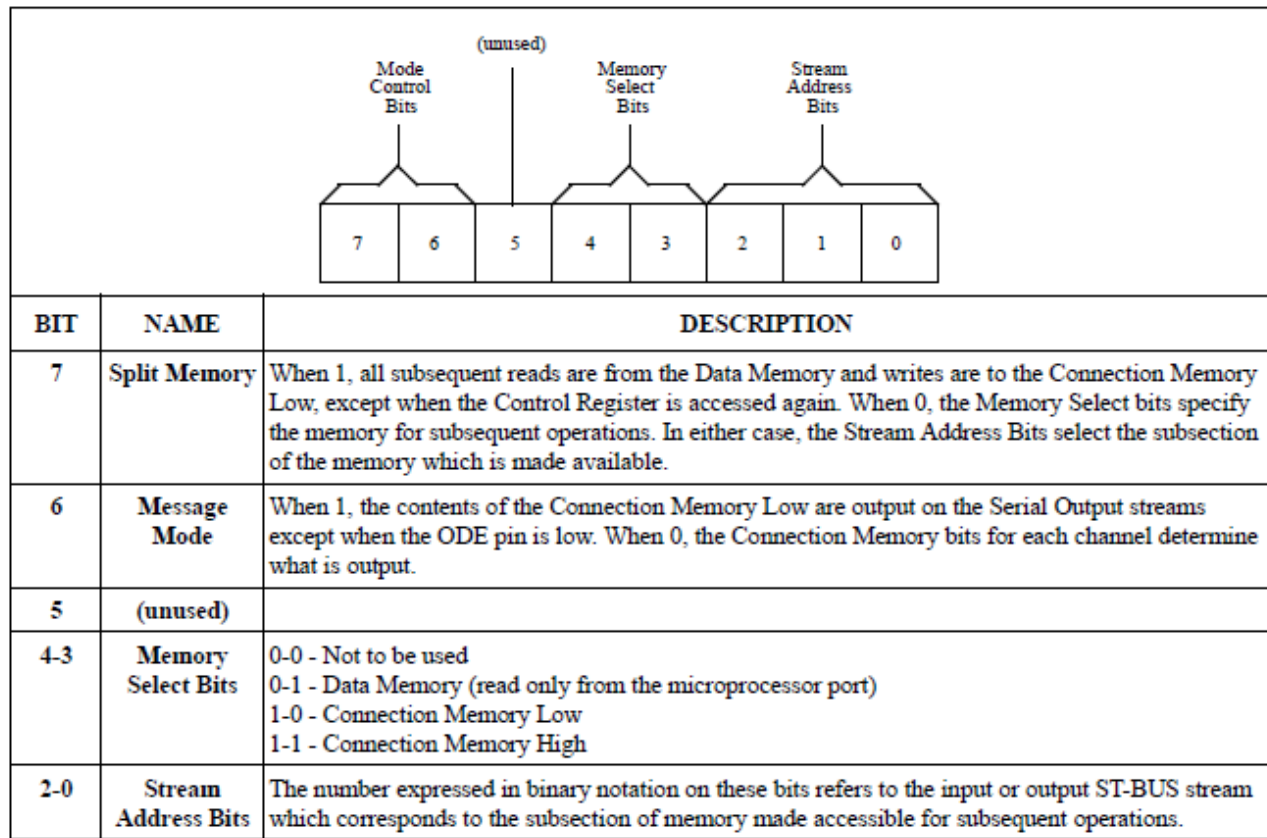

Figure 4 - Control Register Bits

Bit 7 of the Control Register allows split memory operation - reads are from the Data Memory and writes are to the Connection Memory Low.

The other mode control bit, bit 6, puts every output channel on every output stream into active Message Mode; i.e., the contents of the Connection Memory Low are output on the ST-BUS output streams once every frame unless the ODE pin is low. In this mode the chip behaves as if bits 2 and 0 of every Connection Memory High location were 1, regardless of the actual values.

If bit 6 of the Control Register is 0, then bits 2 and 0 of each Connection Memory High location function normally (see Fig. 5). If bit 2 is 1, the associated ST-BUS output channel is in Message Mode; i.e., the byte in the corresponding Connection Memory Low location is transmitted on the stream at that channel. Otherwise, one of the bytes received on the serial inputs is transmitted and the contents of the Connection Memory Low define the ST-BUS input stream and channel where the byte is to be found (see Fig. 6).

If the ODE pin is low, then all serial outputs are high-impedance. If it is high and bit 6 in the Control Register is 1, then all outputs are active. If the ODE pin is high and bit 6 in the Control Register is 0, then the bit 0 in the Connection Memory High location enables the output drivers for the corresponding individual ST-BUS output stream and channel. Bit 0=1 enables the driver and bit 0=0 disables it (see Fig. 5).

Bit 1 of each Connection Memory High location (see Fig. 5) is output on the CSto pin once every frame. To allow for delay in any external control circuitry the bit is output one channel before the corresponding channel on the ST-BUS streams, and the bit for stream 0 is output first in the channel; e.g., bit 1's for channel 9 of streams 0-7 are output synchronously with ST-BUS channel 8 bits 7-0.

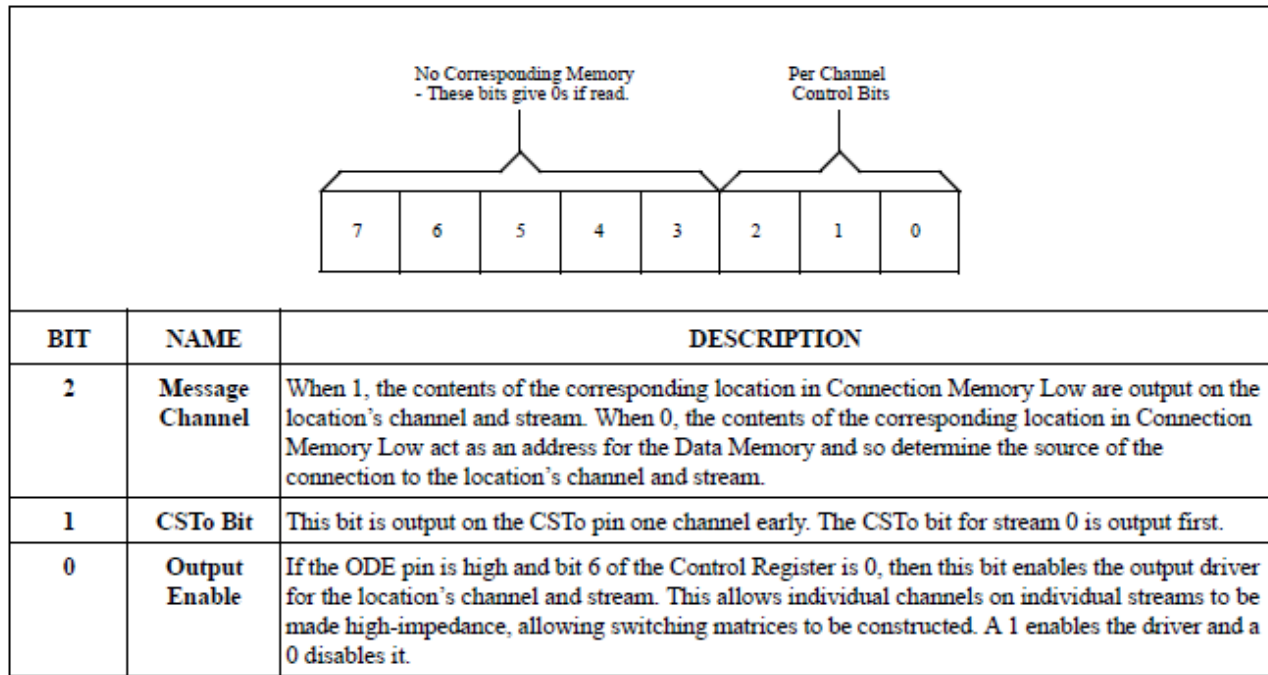

Figure 5 - Connection Memory High Bits

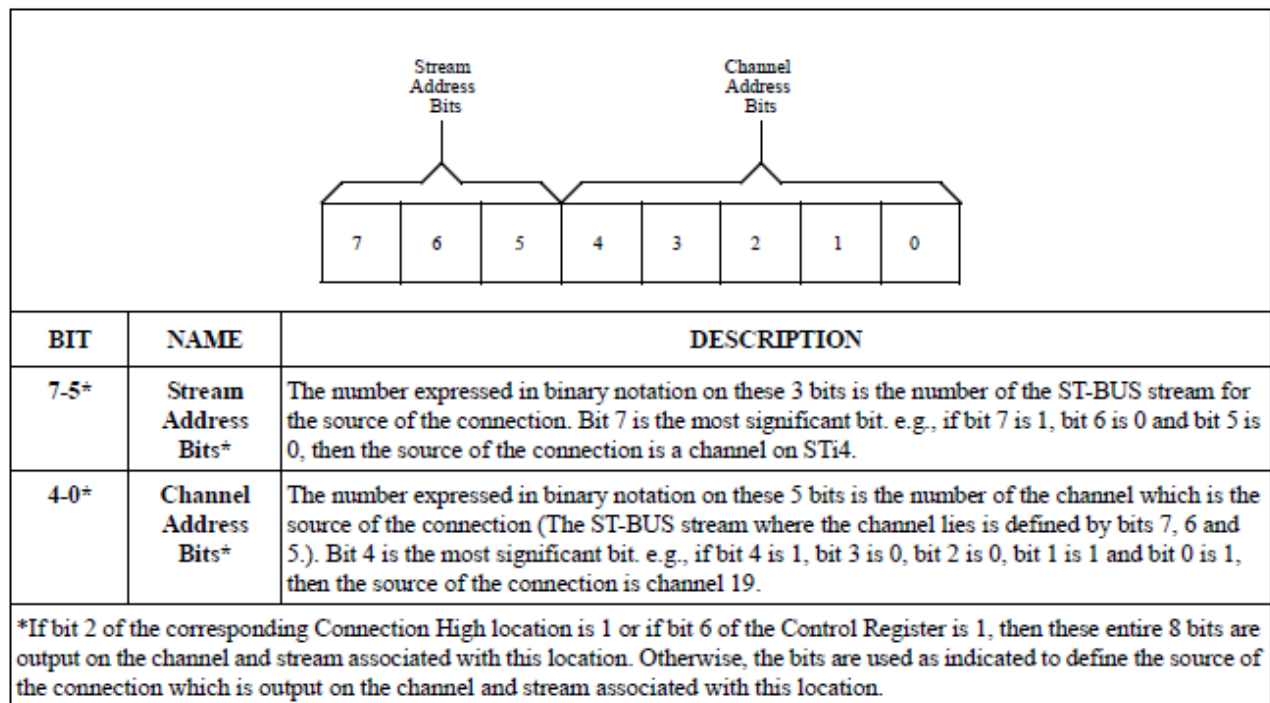

Figure 6 - Connection Memory Low Bits

## Applications

### Use in a Simple Digital Switching System

Figs. 7 and 8 show how MT8980s can be used with MT8964s to form a simple digital switching system. Fig. 7 shows the interface between the MT8980s and the filter/codecs. Fig. 8 shows the position of these components in an example architecture.

The MT8964 filter/codec in Fig. 7 receives and transmits digitized voice signals on the ST-BUS input DR, and ST-BUS output D<sub>X</sub>, respectively. These signals are routed to the ST-BUS inputs and outputs on the top MT8980, which is used as a digital speech switch.

The MT8964 is controlled by the ST-BUS input DC originating from the bottom MT8980, which generates the appropriate signals from an output channel in Message Mode. This architecture optimizes the messaging capability of the line circuit by building signalling logic, e.g., for on-off hook detection, which communicates on an ST-BUS output. This signalling ST-BUS output is monitored by a microprocessor (not shown) through an ST-BUS input on the bottom MT8980.

Fig. 8 shows how a simple digital switching system may be designed using the ST-BUS architecture. This is a private telephone network with 256 extensions which uses a single MT8980 as a speech switch and a second MT8980 for communication with the line interface circuits.

A larger digital switching system may be designed by cascading a number of MT8980s. Fig. 9 shows how four MT8980s may be arranged in a non-blocking configuration which can switch any channel on any of the ST-BUS inputs to any channel on the ST-BUS outputs.

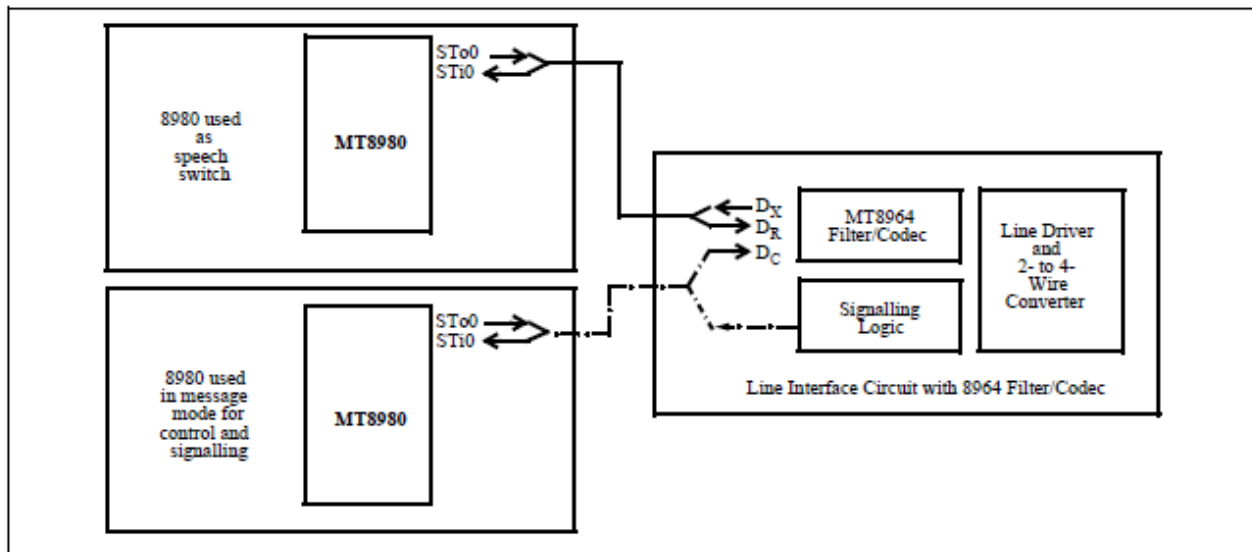

Figure 7 - Example of Typical Interface between 8980s and 8964s for Simple Digital Switching System

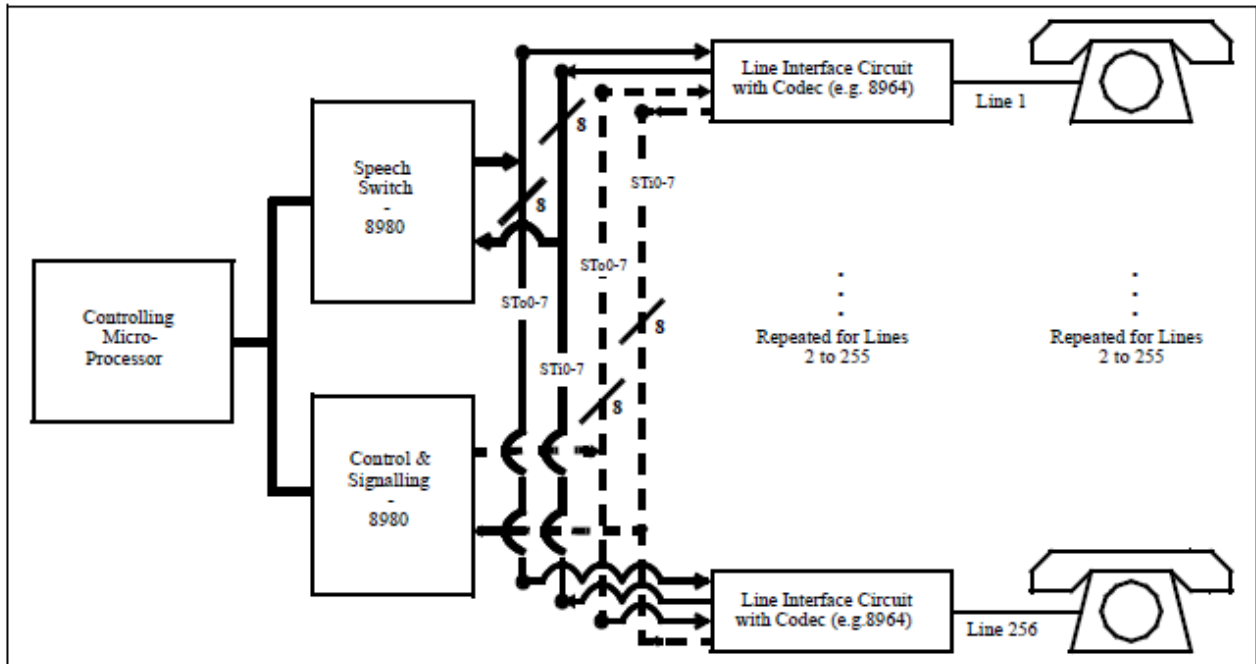

Figure 8 - Example Architecture of a Simple Digital Switching System

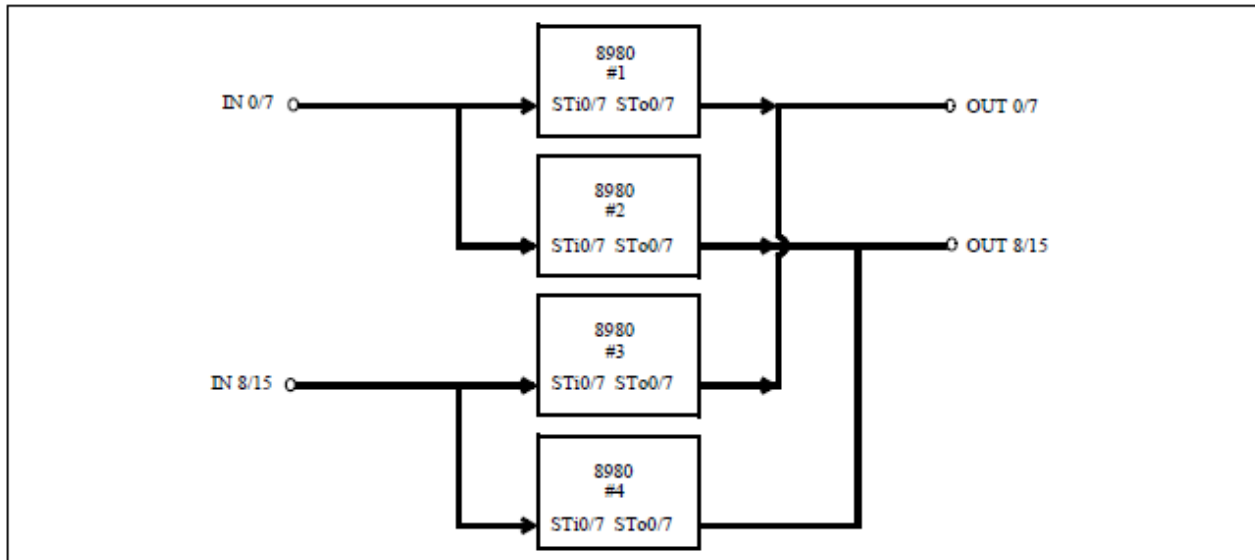

Figure 9 - Four 8980s Arranged in a Non-Blocking 16 x 16 Configuration

**Application Circuit with 6802 Processor**

Fig. 10 shows an example of a complete circuit which may be used to evaluate the chip.

For convenience, a 4 MHz crystal oscillator has been used rather than a 4.096 MHz clock, as both are within the limits of the chip's specifications. The RC delay used with the 393 counters ensures a sufficient hold time for the FP signal, but the values used may have to be changed if faster 393 counters become available.

The chip is shown as memory mapped into the MEK6802D3 system. Chip addresses 00-3F correspond to processor addresses 2000-203F. Delay through the address decoder requires the VMA signal to be used twice to remove glitches. The MEK6802D3 board uses a 10 K $\Omega$  pullup on the MR pin, which would have to be incorporated into the circuit if the board was replaced by a processor.

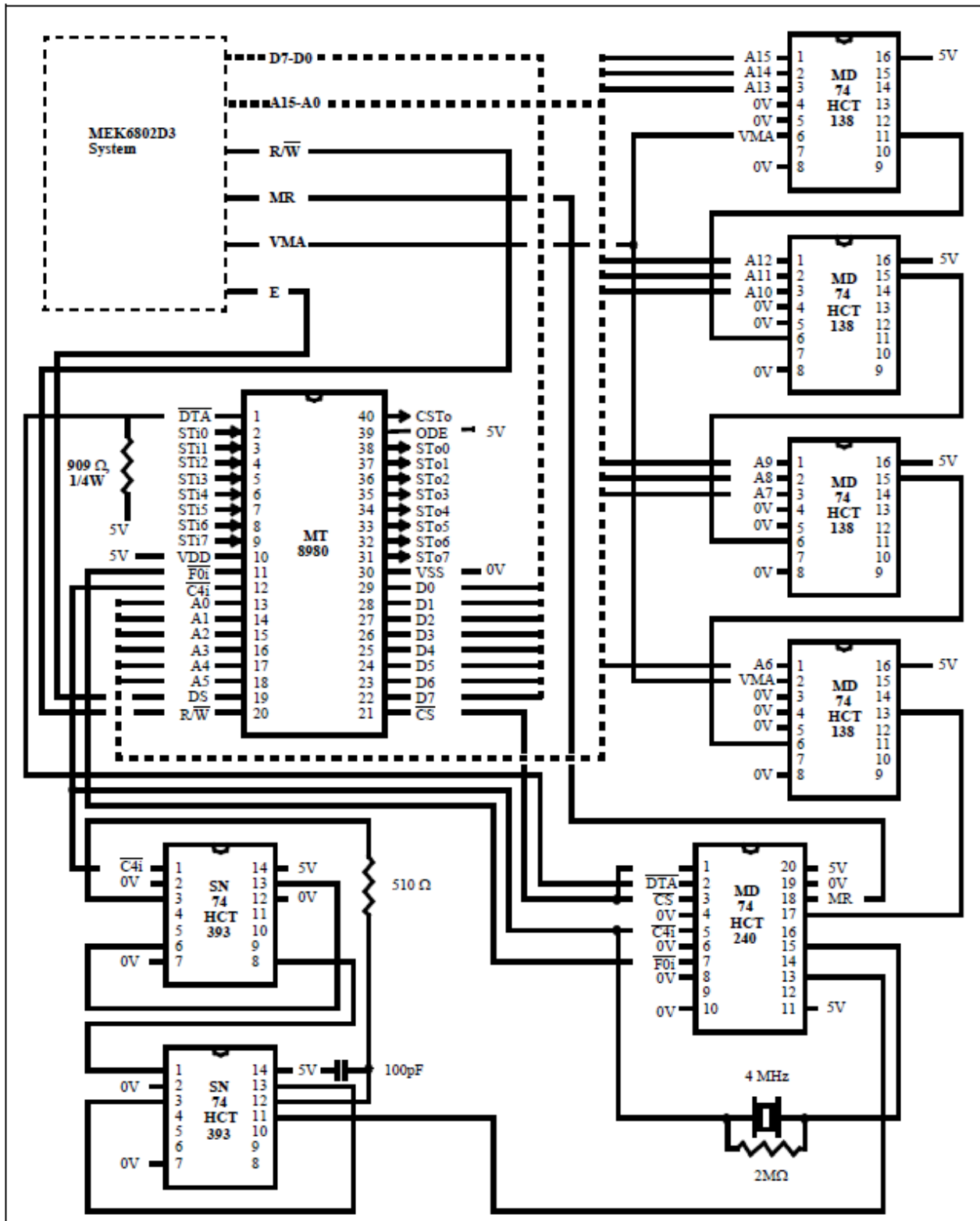

Figure 10 - Application Circuit with 6802

**Absolute Maximum Ratings\***

	Parameter	Symbol	Min.	Max.	Units
1	$V_{DD} - V_{SS}$		-0.3	7	V
2	Voltage on Digital Inputs	$V_I$	$V_{SS}-0.3$	$V_{DD}+0.3$	V
3	Voltage on Digital Outputs	$V_O$	$V_{SS}-0.3$	$V_{DD}+0.3$	V
4	Current at Digital Outputs	$I_O$		40	mA
5	Storage Temperature	$T_S$	-65	+150	°C
6	Package Power Dissipation	$P_D$		2	W

\* Exceeding these values may cause permanent damage. Functional operation under these conditions is not implied.

**Recommended Operating Conditions - Voltages are with respect to ground ( $V_{SS}$ ) unless otherwise stated.**

	Characteristics	Sym.	Min.	Typ.‡	Max.	Units	Test Conditions
1	Operating Temperature	$T_{OP}$	-40		+85	°C	
2	Positive Supply	$V_{DD}$	4.75		5.25	V	
3	Input Voltage	$V_I$	0		$V_{DD}$	V	

‡ Typical figures are at 25°C and are for design aid only: not guaranteed and not subject to production testing.

**DC Electrical Characteristics - Voltages are with respect to ground ( $V_{SS}$ ) unless otherwise stated.**

		Characteristics	Sym.	Min.	Typ.‡				
1	I N P U T S	Supply Current	$I_{DD}$		6	10	mA	Outputs unloaded	
2		Input High Voltage	$V_{IH}$	2.0			V		
3		Input Low Voltage	$V_{IL}$			0.8		V	
4		Input Leakage	$I_{IL}$			5		µA	$V_I$ between $V_{SS}$ and $V_{DD}$
5		Input Pin Capacitance	$C_I$			8		pF	
6	O U T P U T S	Output High Voltage	$V_{OH}$	2.4			V	$I_{OH} = 10$ mA	
7		Output High Current	$I_{OH}$	10	15		mA	Sourcing. $V_{OH}=2.4V$	
8		Output Low Voltage	$V_{OL}$			0.4		V	$I_{OL} = 5$ mA
9		Output Low Current	$I_{OL}$	5	10		mA	Sinking. $V_{OL} = 0.4V$	
10		High Impedance Leakage	$I_{OZ}$			5		µA	$V_O$ between $V_{SS}$ and $V_{DD}$
11		Output Pin Capacitance	$C_O$			8		pF	

‡ Typical figures are at 25°C and are for design aid only: not guaranteed and not subject to production testing.

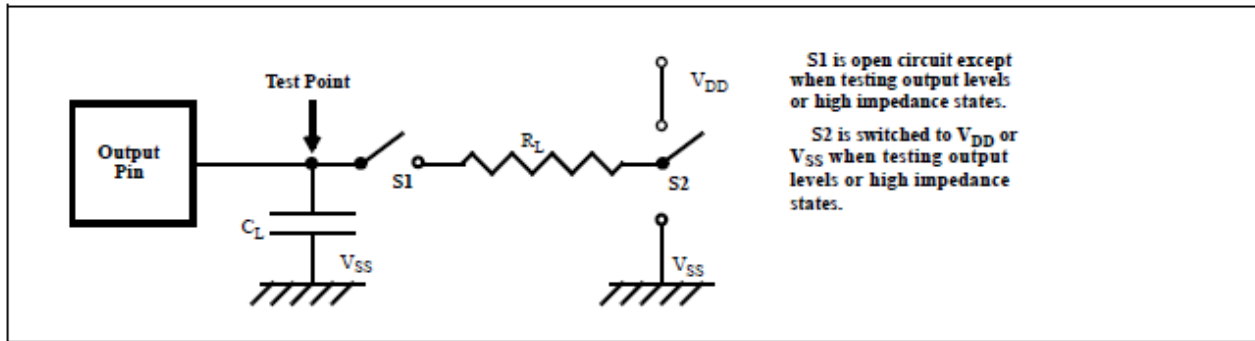

Figure 11 - Output Test Load

AC Electrical Characteristics† - Clock Timing (Figures 12 and 13)

	Characteristics	Sym.	Min.	Typ.‡	Max.	Units	Test Conditions
1	I N P U T S	Clock Period*	$t_{CLK}$	220	244	300	ns
2		Clock Width High	$t_{CH}$	95	122	150	ns
3		Clock Width Low	$t_{CL}$	110	122	150	ns
4		Clock Transition Time	$t_{CTT}$		20		ns
5		Frame Pulse Setup Time	$t_{FPS}$	20		200	ns
6		Frame Pulse Hold Time	$t_{FPH}$	0.020		50	$\mu s$
7		Frame Pulse Width	$t_{FPW}$		244		ns

† Timing is over recommended temperature & power supply voltages.

‡ Typical figures are at 25°C and are for design aid only: not guaranteed and not subject to production testing.

\* Contents of Connection Memory are not lost if the clock stops, however, ST-BUS outputs go into the high impedance state.

**NB:** Frame Pulse is repeated every 512 cycles of C4i.

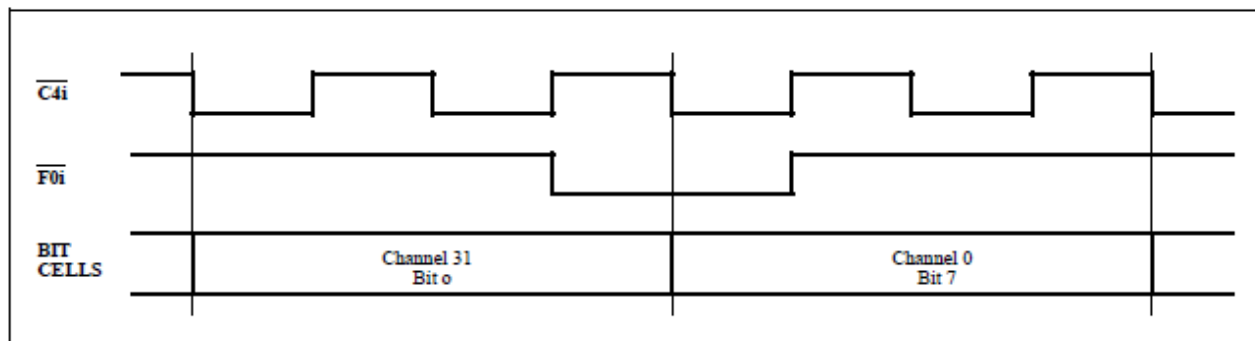

Figure 12 - Frame Alignment

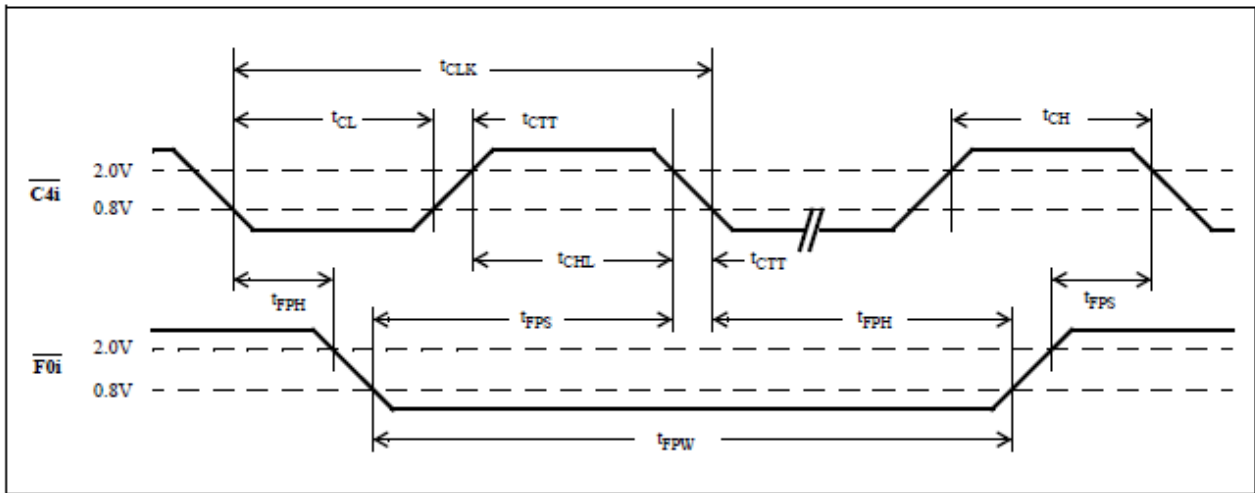

Figure 13 - Clock Timing

AC Electrical Characteristics<sup>†</sup> - Serial Streams (Figures 11, 14, 15 and 16)

		Characteristics	Sym.	Min.	Typ. <sup>‡</sup>	Max,	Units	Test Conditions
1	O U T P U T S	STo0/7 Delay - Active to High Z	t <sub>SAZ</sub>	20	50	80	ns	R <sub>L</sub> =1 KΩ*, C <sub>L</sub> =150 pF
2		ISTo0/7 Delay - High Z to Active	t <sub>SZA</sub>	25	60	125	ns	C <sub>L</sub> =150 pF
3		STo0/7 Delay - Active to Active	t <sub>SAA</sub>	30	65	125	ns	C <sub>L</sub> =150 pF
4		STo0/7 Hold Time	t <sub>SOH</sub>	25	45		ns	C <sub>L</sub> =150 pF
5		Output Driver Enable Delay	t <sub>OED</sub>		45	125	ns	R <sub>L</sub> =1 KΩ*, C <sub>L</sub> =150 pF
6		External Control Hold Time	t <sub>XCH</sub>	0	50		ns	C <sub>L</sub> =150 pF
7		External Control Delay	t <sub>XCD</sub>		75	110	ns	C <sub>L</sub> =150 pF
8	I N	Serial Input Setup Time	t <sub>SIS</sub>		-40	-20	ns	
9		Serial Input Hold Time	t <sub>SIH</sub>	90			ns	

<sup>†</sup> Timing is over recommended temperature & power supply voltages.

<sup>‡</sup> Typical figures are at 25°C and are for design aid only: not guaranteed and not subject to production testing.

\* High Impedance is measured by pulling to the appropriate rail with R<sub>L</sub>, with timing corrected to cancel time taken to discharge C<sub>L</sub>.

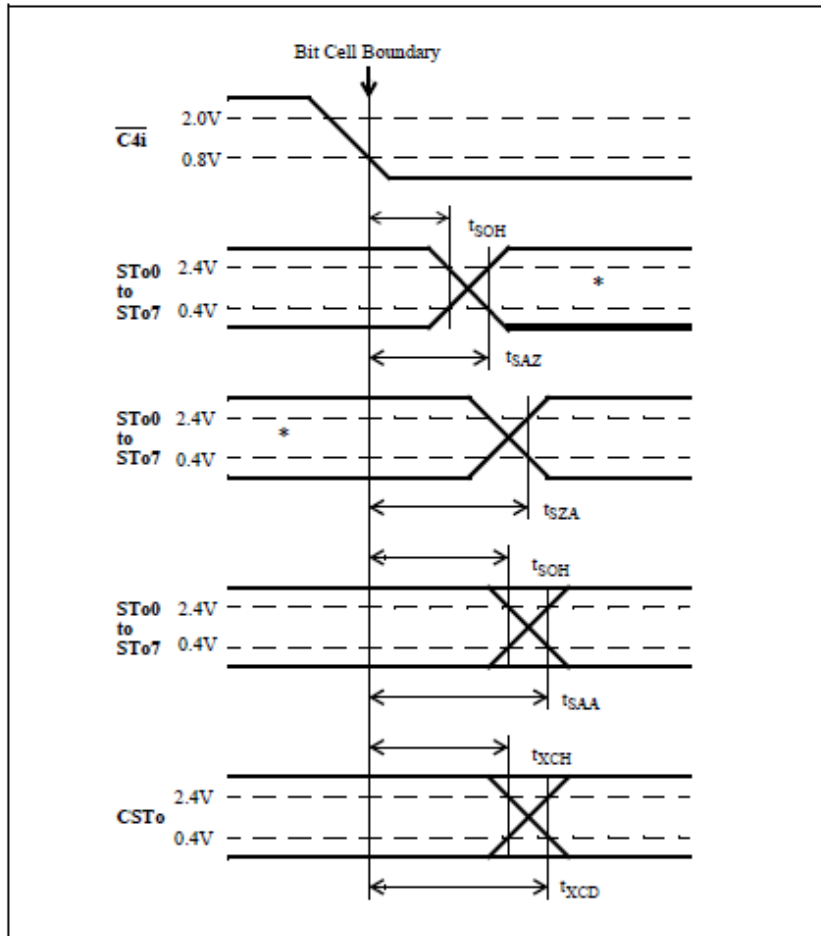

Figure 14 - Serial Outputs and External Control

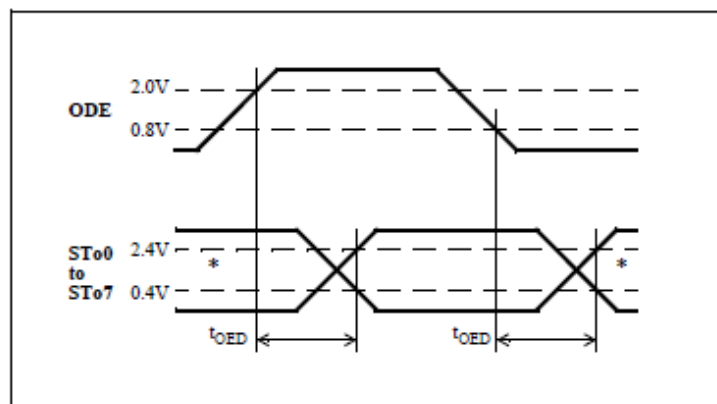

Figure 15 - Output Driver Enable

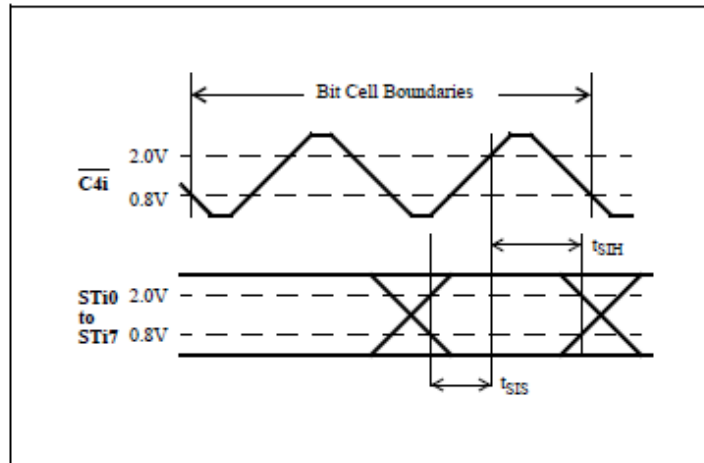

Figure 16 - Serial Inputs

AC Electrical Characteristics<sup>†</sup> - Processor Bus (Figures 11 and 17)

	Characteristics	Sym.	Min.	Typ.‡	Max.	Units	Test Conditions	
1	Chip Select Setup Time	$t_{CSS}$	20	0		ns		
2	Read/Write Setup Time	$t_{RWS}$	25	5		ns		
3	Address Setup Time	$t_{ADS}$	25	5		ns		
4	Acknowledgement Delay	Fast	$t_{AKD}$		40	100	ns	$C_L=150$ pF
		Slow	$t_{AKD}$	2.7		7.2	cycles	$\overline{C4i}$ cycles <sup>1</sup>
5	Fast Write Data Setup Time	$t_{FWS}$	20			ns		
6	Slow Write Data Delay	$t_{SWD}$		2.0	1.7	cycles	$\overline{C4i}$ cycles <sup>1</sup>	
7	Read Data Setup Time	$t_{RDS}$			0.5	cycles	$\overline{C4i}$ cycles <sup>1</sup> , $C_L=150$ pF	
8	Data Hold Time	Read	$t_{DHT}$	20			ns	$R_L=1$ K $\Omega^*$ , $C_L=150$ pF
		Write	$t_{DHT}$	20	10		ns	
9	Read Data To High Impedance	$t_{RDZ}$		50	90	ns	$R_L=1$ K $\Omega^*$ , $C_L=150$ pF	
10	Chip Select Hold Time	$t_{CSH}$	0			ns		
11	Read/Write Hold Time	$t_{RWH}$	0			ns		
12	Address Hold Time	$t_{ADH}$	0			ns		
13	Acknowledgement Hold Time	$t_{AKH}$	10	60	80	ns	$R_L=1$ K $\Omega^*$ , $C_L=150$ pF	

<sup>†</sup> Timing is over recommended temperature & power supply voltages.

<sup>‡</sup> Typical figures are at 25°C and are for design aid only: not guaranteed and not subject to production testing.

\* High Impedance is measured by pulling to the appropriate rail with  $R_L$ , with timing corrected to cancel time taken to discharge  $C_L$ .

Note 1. Processor accesses are dependent on the  $\overline{C4i}$  clock, and so some timings are expressed as multiples of the  $\overline{C4i}$  clock period.

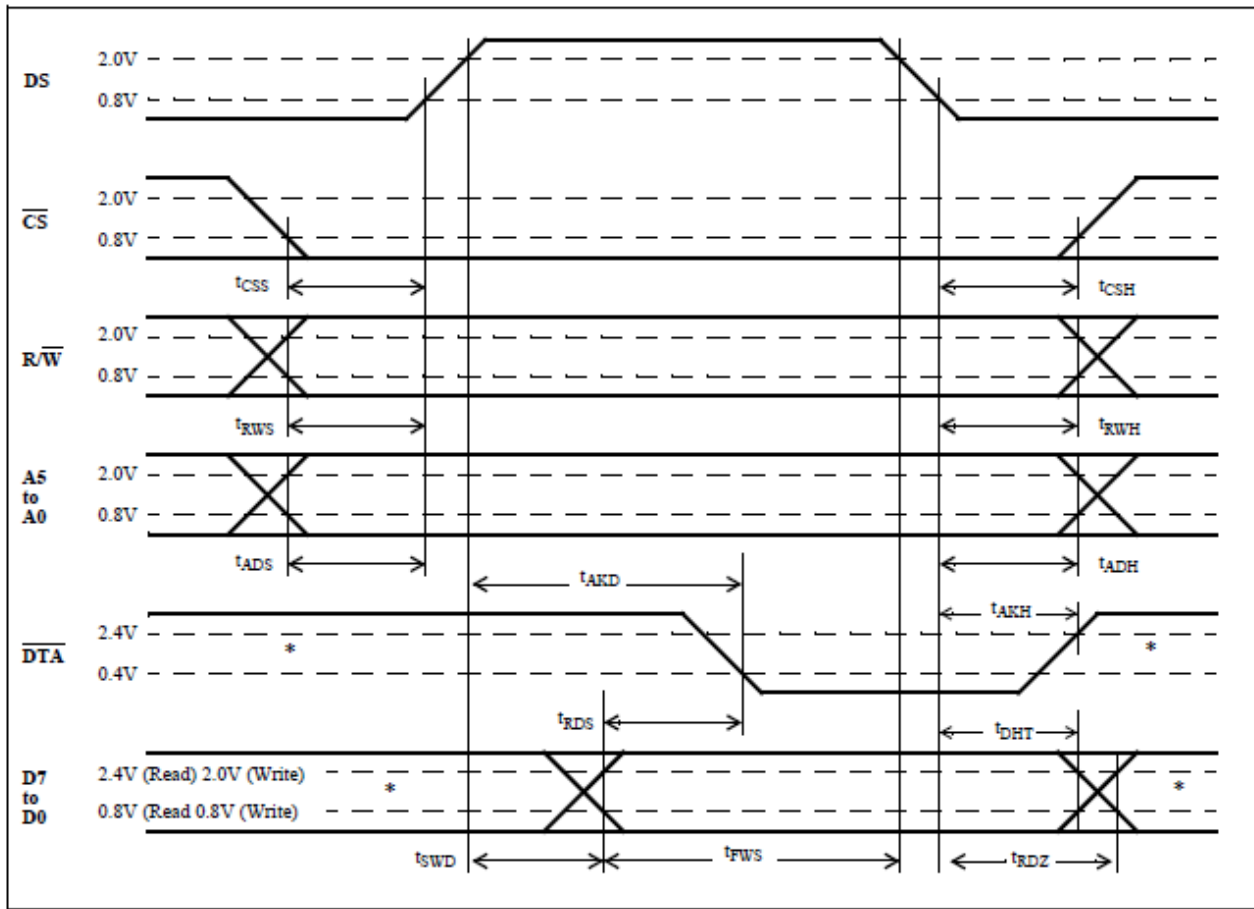
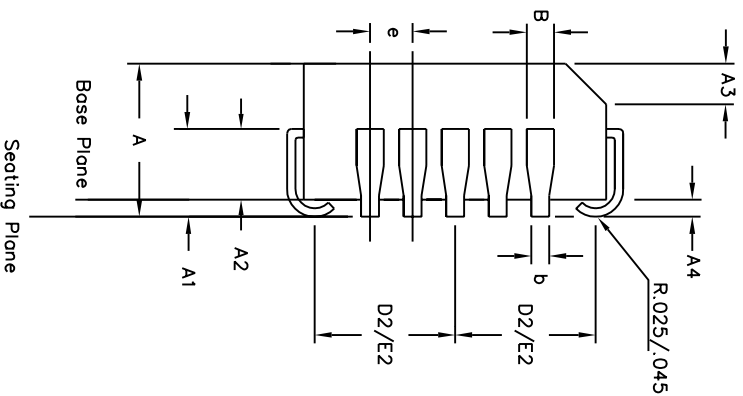
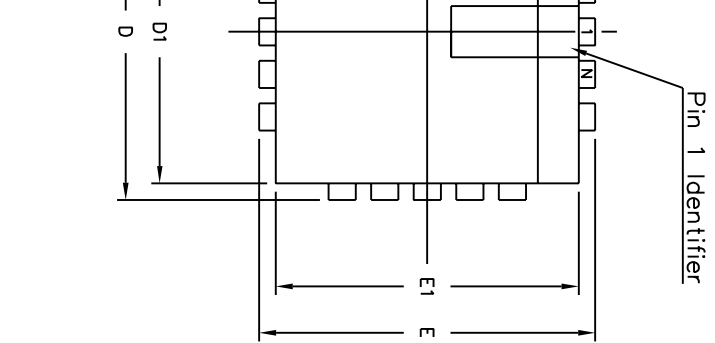

Figure 17 - Processor Bus



Symbol	Control Dimensions in inches		Altern. Dimensions in millimetres	
	MIN	MAX	MIN	MAX
A	0.165	0.180	4.19	4.57
A1	0.090	0.120	2.29	3.05
A2	0.062	0.083	1.57	2.11
A3	0.042	0.056	1.07	1.42
A4	0.020	—	0.51	—
D	0.685	0.695	17.40	17.65
D1	0.650	0.656	16.51	16.66
D2	0.291	0.319	7.39	8.10
E	0.685	0.695	17.40	17.65
E1	0.650	0.656	16.51	16.66
E2	0.291	0.319	7.39	8.10
B	0.026	0.032	0.66	0.81
b	0.013	0.021	0.33	0.53
e	0.050	BSC	1.27	BSC
Pin features				
ND	11			
NE	11			
N	44			
Note	Square			
Conforms to JEDEC MS-018AC Iss. A				

ances conform to ANSI Y14.5M-1982  
do not include mould protrusions.  
on is 0.010" per side. Dimensions D1 and E1  
mismatch and are determined at the  
and E1 are measured at the extreme material  
r lower parting line.  
inches.  
rminids.  
120° minimum bend.



Previous package codes

HP / P

Package Code QA

Package Outline for  
44 lead PLCC

GPD000003

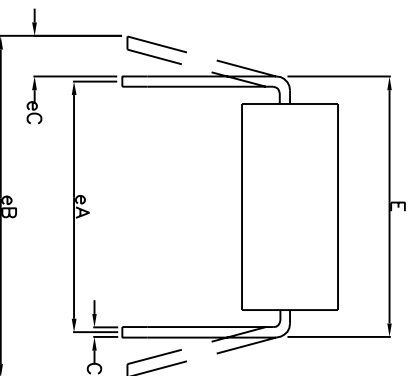
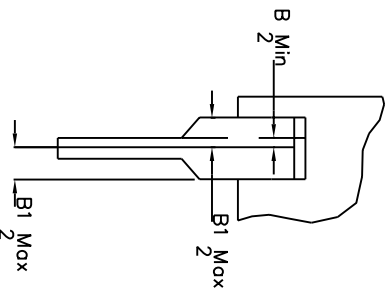
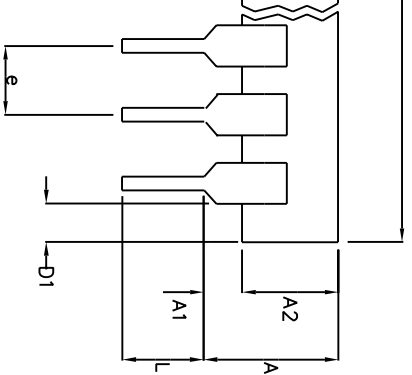
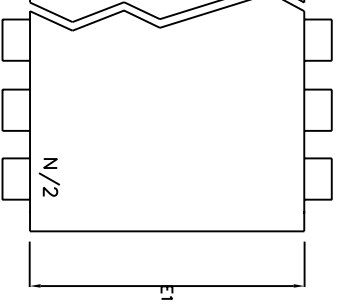

	Min	Max	Min	Max
	mm	mm	Inches	Inches
A		6.35		0.250
A1	0.38		0.015	
A2	3.18	4.95	0.125	0.195
B	0.36	0.56	0.014	0.022
B1	0.76	1.78	0.030	0.070
C	0.20	0.38	0.008	0.015
D	50.29	53.21	1.980	2.095
D1	0.13		0.005	
E	15.24	15.88	0.600	0.625
E1	12.32	14.73	0.485	0.580
e	2.54	BSC	0.100	BSC
eA	15.24	BSC	0.600	BSC
eB		17.78		0.700
L	2.92	5.08	0.115	0.200
N		40		40

Conforms to Jeduc MS-011AC ISS.B

Dimensions are measured with the package seated in the Seating Plane. Dimensions shall include mold flash or protrusions. Mold flash or protrusion shall not exceed 0.010 inch. Dimensions are measured with leads constrained to be perpendicular to plane T. Dimensions are measured at the lead tips with the leads unconstrained; eC must be zero or greater.



**ZARLINK**  
SEMICONDUCTOR

Previous package codes

DP / E

Package Code

DA

Package Outline for  
40 lead PDIP

GPD000073



**For more information about all Zarlink products  
visit our Web Site at  
[www.zarlink.com](http://www.zarlink.com)**

Information relating to products and services furnished herein by Zarlink Semiconductor Inc. or its subsidiaries (collectively "Zarlink") is believed to be reliable. However, Zarlink assumes no liability for errors that may appear in this publication, or for liability otherwise arising from the application or use of any such information, product or service or for any infringement of patents or other intellectual property rights owned by third parties which may result from such application or use. Neither the supply of such information or purchase of product or service conveys any license, either express or implied, under patents or other intellectual property rights owned by Zarlink or licensed from third parties by Zarlink, whatsoever. Purchasers of products are also hereby notified that the use of product in certain ways or in combination with Zarlink, or non-Zarlink furnished goods or services may infringe patents or other intellectual property rights owned by Zarlink.

This publication is issued to provide information only and (unless agreed by Zarlink in writing) may not be used, applied or reproduced for any purpose nor form part of any order or contract nor to be regarded as a representation relating to the products or services concerned. The products, their specifications, services and other information appearing in this publication are subject to change by Zarlink without notice. No warranty or guarantee express or implied is made regarding the capability, performance or suitability of any product or service. Information concerning possible methods of use is provided as a guide only and does not constitute any guarantee that such methods of use will be satisfactory in a specific piece of equipment. It is the user's responsibility to fully determine the performance and suitability of any equipment using such information and to ensure that any publication or data used is up to date and has not been superseded. Manufacturing does not necessarily include testing of all functions or parameters. These products are not suitable for use in any medical products whose failure to perform may result in significant injury or death to the user. All products and materials are sold and services provided subject to Zarlink's conditions of sale which are available on request.

Purchase of Zarlink's I2C components conveys a license under the Philips I2C Patent rights to use these components in an I2C System, provided that the system conforms to the I2C Standard Specification as defined by Philips.

Zarlink, ZL, the Zarlink Semiconductor logo and the Legerity logo and combinations thereof, VoiceEdge, VoicePort, SLAC, ISLIC, ISLAC and VoicePath are trademarks of Zarlink Semiconductor Inc.

**TECHNICAL DOCUMENTATION - NOT FOR RESALE**

---

## Looking for pricing, stock, or lifecycle information?

Click below to explore more details on WIN SOURCE:

- ⊖ [View MT8980DPR1 on WIN SOURCE](#)
- ⊖ [Microsemi Corporation Information](#)

## Optimize Your Supply Chain with WIN SOURCE Solutions

- ✓ Global Sourcing Solution
- ✓ Obsolete Management
- ✓ Cost Control Management
- ✓ Shortage Management
- ✓ Alternative Solution
- ✓ Excess Inventory Management