



**THE DATASHEET OF
MT49H8M36BM-25 IT:B TR**



CIO RLDRAM 2

MT49H32M9 – 32 Meg x 9 x 8 Banks

MT49H16M18 – 16 Meg x 18 x 8 Banks

MT49H8M36 – 8 Meg x 36 x 8 Banks

Features

- 533 MHz DDR operation (1.067 Gb/s/pin data rate)
- 38.4 Gb/s peak bandwidth (x36 at 533 MHz clock frequency)
- Organization
 - 32 Meg x 9, 16 Meg x 18, and 8 Meg x 36
- 8 internal banks for concurrent operation and maximum bandwidth
- Reduced cycle time (15ns at 533 MHz)
- Nonmultiplexed addresses (address multiplexing option available)
- SRAM-type interface
- Programmable READ latency (RL), row cycle time, and burst sequence length
- Balanced READ and WRITE latencies in order to optimize data bus utilization
- Data mask for WRITE commands
- Differential input clocks (CK, CK#)
- Differential input data clocks (DKx, DKx#)
- On-die DLL generates CK edge-aligned data and output data clock signals
- Data valid signal (QVLD)
- 32ms refresh (8K refresh for each bank; 64K refresh command must be issued in total each 32ms)
- HSTL I/O (1.5V or 1.8V nominal)
- 25–60Ω matched impedance outputs
- 2.5V V_{EXT}, 1.8V V_{DD}, 1.5V or 1.8V V_{DDQ} I/O
- On-die termination (ODT) R_{TT}

Options¹

- Clock cycle timing
 - 1.875ns @ t_{RC} = 15ns
 - 2.5ns @ t_{RC} = 15ns
 - 2.5ns @ t_{RC} = 20ns
 - 3.3ns @ t_{RC} = 20ns
 - 5.0ns @ t_{RC} = 20ns
- Configuration
 - 32 Meg x 9
 - 16 Meg x 18
 - 8 Meg x 36
- Operating temperature
 - Commercial (0° to +95°C)
 - Industrial (T_C = –40°C to +95°C; T_A = –40°C to +85°C)
- Package
 - 144-ball μBGA
 - 144-ball μBGA (Pb-free)
 - 144-ball FBGA
 - 144-ball FBGA (Pb-free)
- Revision

Marking

- 18
- 25E
- 25
- 33
- 5
- 32M9
- 16M18
- 8M36
- None
- IT
- FM
- BM
- TR
- SJ
- :B

Note: 1. Not all options listed can be combined to define an offered product. Use the part catalog search on micron.com for available offerings.

BGA Marking Decoder

Due to space limitations, BGA-packaged components have an abbreviated part marking that is different from the part number. Micron's BGA Part Marking Decoder is available on Micron's web site at micron.com.

Figure 1: 288Mb RLDRAM 2 CIO Part Numbers

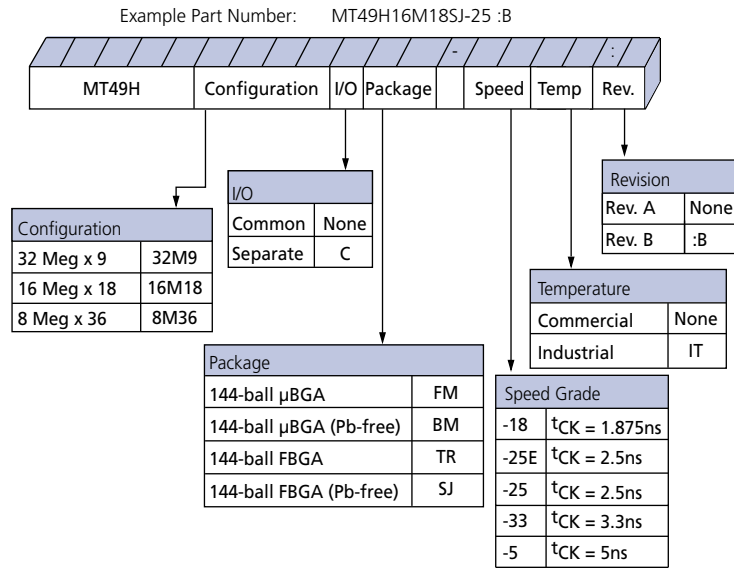

Contents

General Description	7
Functional Block Diagrams	8
Ball Assignments and Descriptions	11
Package Dimensions	16
Electrical Specifications – I _{DD}	18
Absolute Maximum Ratings	22
AC and DC Operating Conditions	22
Input Slew Rate Derating	25
Capacitance	28
AC Electrical Characteristics	29
Temperature and Thermal Impedance	32
Commands	34
MODE REGISTER SET (MRS) Command	35
Configuration Tables	37
Burst Length (BL)	37
Address Multiplexing	39
DLL RESET	39
Drive Impedance Matching	39
On-Die Termination (ODT)	40
READ Command	41
WRITE Command	42
AUTO REFRESH (AREF) Command	43
INITIALIZATION Operation	44
READ Operations	47
WRITE Operations	53
AUTO REFRESH Operation	58
On-Die Termination	59
Multiplexed Address Mode	62
Configuration Tables	66
REFRESH Command in Multiplexed Address Mode	66
IEEE 1149.1 Serial Boundary Scan (JTAG)	71
Disabling the JTAG Feature	71
Test Access Port (TAP)	71
Test Clock (TCK)	71
Test Mode Select (TMS)	71
Test Data-In (TDI)	72
Test Data-Out (TDO)	72
TAP Controller	73
Test-Logic-Reset	73
Run-Test/Idle	73
Select-DR-Scan	73
Capture-DR	73
Shift-DR	73
Exit1-DR, Pause-DR, and Exit2-DR	73
Update-DR	73
Instruction Register States	73
TAP Reset	74
TAP Registers	75
Instruction Register	75
Bypass Register	75



288Mb: x9, x18, x36 CIO RLDRAM 2 Features

Boundary Scan Register	75
Identification (ID) Register	75
TAP Instruction Set	76
EXTEST	76
IDCODE	76
SAMPLE/PRELOAD	76
CLAMP	77
High-Z	77
BYPASS	77
Reserved for Future Use	77

List of Figures

Figure 1: 288Mb RLDRAM 2 CIO Part Numbers	2
Figure 2: State Diagram	7
Figure 3: 32 Meg x 9 Functional Block Diagram	8
Figure 4: 16 Meg x 18 Functional Block Diagram	9
Figure 5: 8 Meg x 36 Functional Block Diagram	10
Figure 6: 144-Ball μ BGA	16
Figure 7: 144-Ball FBGA	17
Figure 8: Minimum Slew Rate	23
Figure 9: Clock Input	24
Figure 10: Nominal $t_{AS}/t_{CS}/t_{DS}$ and $t_{AH}/t_{CH}/t_{DH}$ Slew Rate	28
Figure 11: AC Outputs – Equivalent Load	31
Figure 12: Example Temperature Test Point Location	33
Figure 13: Mode Register Set	35
Figure 14: Mode Register Definition in Nonmultiplexed Address Mode	36
Figure 15: Read Burst Lengths	38
Figure 16: On-Die Termination-Equivalent Circuit	40
Figure 17: READ Command	41
Figure 18: WRITE Command	42
Figure 19: AUTO REFRESH Command	43
Figure 20: Power-Up/Initialization Sequence	45
Figure 21: Power-Up/Initialization Flow Chart	46
Figure 22: Basic READ Burst Timing	47
Figure 23: Consecutive READ Bursts (BL = 2)	48
Figure 24: Consecutive READ Bursts (BL = 4)	49
Figure 25: READ-to-WRITE	49
Figure 26: Read Data Valid Window for x9 Device	50
Figure 27: Read Data Valid Window for x18 Device	51
Figure 28: Read Data Valid Window for x36 Device	52
Figure 29: WRITE Burst	53
Figure 30: Consecutive WRITE-to-WRITE	54
Figure 31: WRITE-to-READ	55
Figure 32: WRITE-to-READ – Separated by Two NOP Commands	56
Figure 33: WRITE – DM Operation	57
Figure 34: AUTO REFRESH Cycle	58
Figure 35: READ Burst with ODT	59
Figure 36: READ-NOP-READ with ODT	60
Figure 37: READ-to-WRITE with ODT	61
Figure 38: Command Description in Multiplexed Address Mode	62
Figure 39: Power-Up/Initialization Sequence in Multiplexed Address Mode	63
Figure 40: Mode Register Definition in Multiplexed Address Mode	64
Figure 41: Burst REFRESH Operation with Multiplexed Addressing	66
Figure 42: Consecutive WRITE Bursts with Multiplexed Addressing	67
Figure 43: WRITE-to-READ with Multiplexed Addressing	68
Figure 44: Consecutive READ Bursts with Multiplexed Addressing	69
Figure 45: READ-to-WRITE with Multiplexed Addressing	70
Figure 46: TAP Controller State Diagram	74
Figure 47: TAP Controller Block Diagram	74
Figure 48: JTAG Operation – Loading Instruction Code and Shifting Out Data	78
Figure 49: TAP Timing	78

List of Tables

Table 1: 32 Meg x 9 Ball Assignments (Top View)	11
Table 2: 16 Meg x 18 Ball Assignments (Top View)	12
Table 3: 8 Meg x 36 Ball Assignments (Top View)	13
Table 4: Ball Descriptions	14
Table 5: I _{DD} Operating Conditions and Maximum Limits – Rev. A	18
Table 6: I _{DD} Operating Conditions and Maximum Limits – Rev. B	20
Table 7: Absolute Maximum Ratings	22
Table 8: DC Electrical Characteristics and Operating Conditions	22
Table 9: Input AC Logic Levels	23
Table 10: Differential Input Clock Operating Conditions	24
Table 11: Address and Command Setup and Hold Derating Values	25
Table 12: Data Setup and Hold Derating Values	27
Table 13: Capacitance – μ BGA	28
Table 14: Capacitance – FBGA	28
Table 15: AC Electrical Characteristics	29
Table 16: Temperature Limits	32
Table 17: Thermal Impedance	33
Table 18: Thermal Impedance	33
Table 19: Description of Commands	34
Table 20: Command Table	34
Table 21: Cycle Time and READ/WRITE Latency Configuration Table	37
Table 22: Address Widths at Different Burst Lengths	38
Table 23: On-Die Termination DC Parameters	40
Table 24: Address Mapping in Multiplexed Address Mode	65
Table 25: Cycle Time and READ/WRITE Latency Configuration in Multiplexed Mode	66
Table 26: Instruction Codes	76
Table 27: TAP Input AC Logic Levels	79
Table 28: TAP AC Electrical Characteristics	79
Table 29: TAP DC Electrical Characteristics and Operating Conditions	80
Table 30: Identification Register Definitions	80
Table 31: Scan Register Sizes	80
Table 32: Boundary Scan (Exit) Order	80

General Description

The Micron® reduced latency DRAM (RLDRAM®) 2 is a high-speed memory device designed for high-bandwidth data storage such as telecommunications, networking, and cache applications. The chip’s 8-bank architecture is optimized for sustainable high-speed operation.

The DDR I/O interface transfers two data words per clock cycle at the I/O balls. Output data is referenced to the free-running output data clock.

Commands, addresses, and control signals are registered at every positive edge of the differential input clock, while input data is registered at both positive and negative edges of the input data clock(s).

Read and write accesses to the device are burst-oriented. The burst length (BL) is programmable to 2, 4, or 8 by setting the mode register.

The device is supplied with 2.5V and 1.8V for the core and 1.5V or 1.8V for the output drivers.

Bank-scheduled refresh is supported with the row address generated internally.

The 144-ball package is used to enable ultra high-speed data transfer rates and a simple upgrade path from early generation devices.

Figure 2: State Diagram

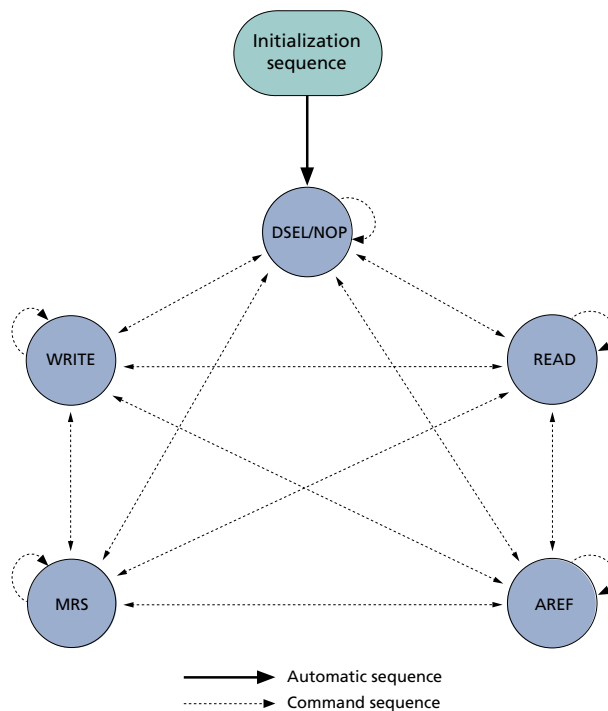

Functional Block Diagrams

Figure 3: 32 Meg x 9 Functional Block Diagram

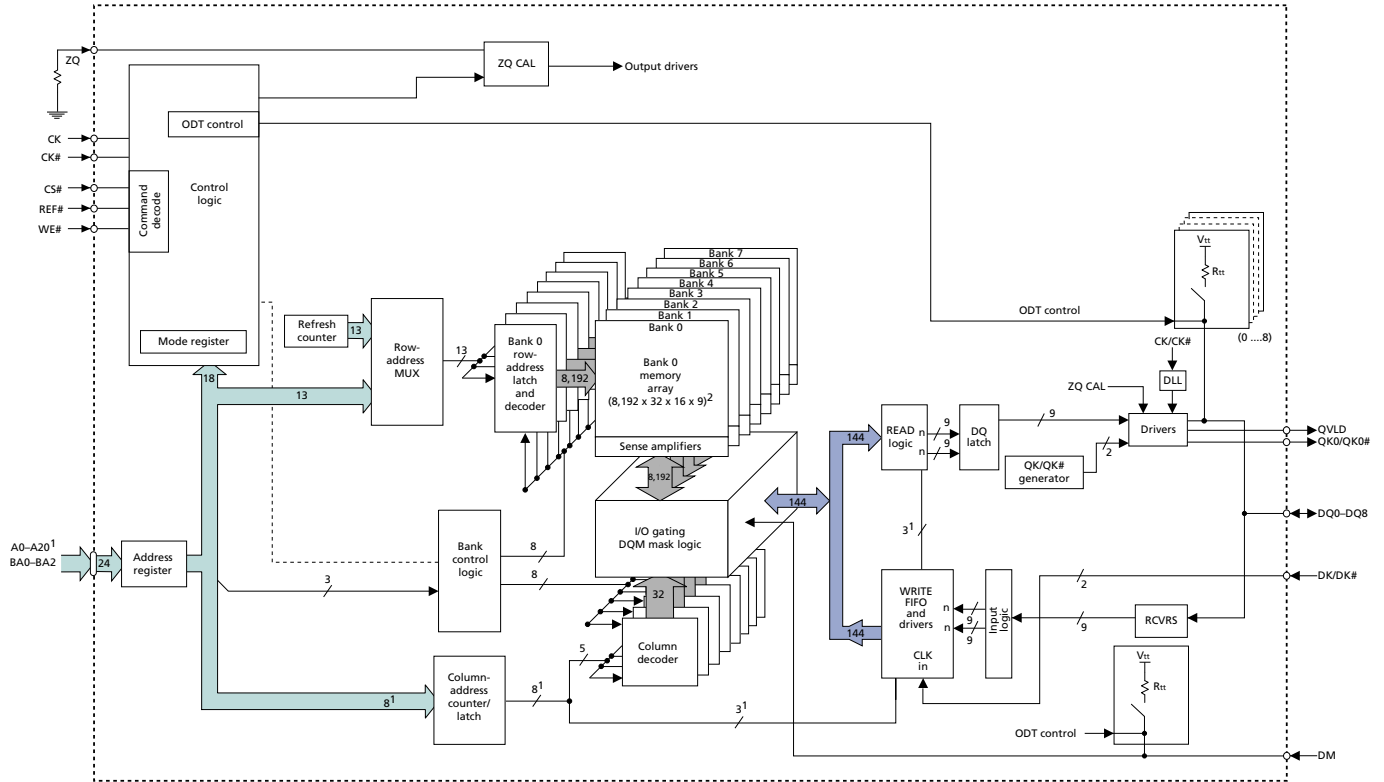

- Notes: 1. Examples for BL = 2; column address will be reduced with an increase in burst length.
2. $16 = (\text{length of burst}) \times 2^{(\text{number of column addresses to WRITE FIFO and READ logic})}$.

Figure 4: 16 Meg x 18 Functional Block Diagram

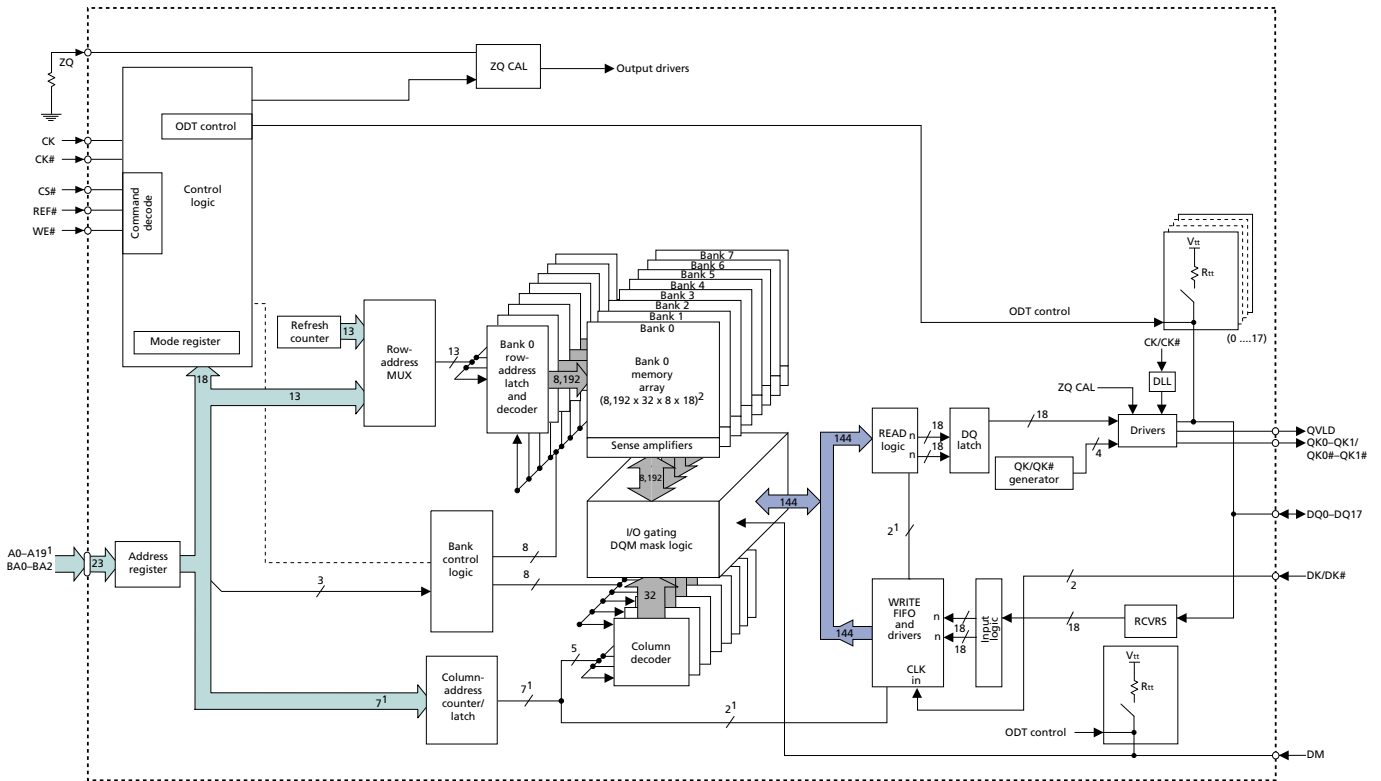

- Notes: 1. Examples for BL = 2; column address will be reduced with an increase in burst length.
 2. $8 = (\text{length of burst}) \times 2^{(\text{number of column addresses to WRITE FIFO and READ logic})}$.

Ball Assignments and Descriptions

Table 1: 32 Meg x 9 Ball Assignments (Top View)

	1	2	3	4	5	6	7	8	9	10	11	12
A	V _{REF}	V _{SS}	V _{EXT}	V _{SS}					V _{SS}	V _{EXT}	TMS	TCK
B	V _{DD}	DNU ⁴	DNU ⁴	V _{SSQ}					V _{SSQ}	DQ0	DNU ⁴	V _{DD}
C	V _{TT}	DNU ⁴	DNU ⁴	V _{DDQ}					V _{DDQ}	DQ1	DNU ⁴	V _{TT}
D	A22 ¹	DNU ⁴	DNU ⁴	V _{SSQ}					V _{SSQ}	QK0#	QK0	V _{SS}
E	A21 ²	DNU ⁴	DNU ⁴	V _{DDQ}					V _{DDQ}	DQ2	DNU ⁴	A20
F	A5	DNU ⁴	DNU ⁴	V _{SSQ}					V _{SSQ}	DQ3	DNU ⁴	QVLD
G	A8	A6	A7	V _{DD}					V _{DD}	A2	A1	A0
H	B2	A9	V _{SS}	V _{SS}					V _{SS}	V _{SS}	A4	A3
J	NF ³	NF ³	V _{DD}	V _{DD}					V _{DD}	V _{DD}	B0	CK
K	DK	DK#	V _{DD}	V _{DD}					V _{DD}	V _{DD}	B1	CK#
L	REF#	CS#	V _{SS}	V _{SS}					V _{SS}	V _{SS}	A14	A13
M	WE#	A16	A17	V _{DD}					V _{DD}	A12	A11	A10
N	A18	DNU ⁴	DNU ⁴	V _{SSQ}					V _{SSQ}	DQ4	DNU ⁴	A19
P	A15	DNU ⁴	DNU ⁴	V _{DDQ}					V _{DDQ}	DQ5	DNU ⁴	DM
R	V _{SS}	DNU ⁴	DNU ⁴	V _{SSQ}					V _{SSQ}	DQ6	DNU ⁴	V _{SS}
T	V _{TT}	DNU ⁴	DNU ⁴	V _{DDQ}					V _{DDQ}	DQ7	DNU ⁴	V _{TT}
U	V _{DD}	DNU ⁴	DNU ⁴	V _{SSQ}					V _{SSQ}	DQ8	DNU ⁴	V _{DD}
V	V _{REF}	ZQ	V _{EXT}	V _{SS}					V _{SS}	V _{EXT}	TDO	TDI

- Notes:
1. Reserved for future use. This signal is not connected.
 2. Reserved for future use. This signal is internally connected and has parasitic characteristics of an address input signal.
 3. No function. This signal is internally connected and has parasitic characteristics of a clock input signal. This may optionally be connected to GND.
 4. Do not use. This signal is internally connected and has parasitic characteristics of a I/O. This may optionally be connected to GND. Note that if ODT is enabled on Rev. A die, these pins will be connected to V_{TT}. The DNU pins are High-Z on Rev. B die when ODT is enabled.

Table 2: 16 Meg x 18 Ball Assignments (Top View)

	1	2	3	4	5	6	7	8	9	10	11	12
A	V _{REF}	V _{SS}	V _{EXT}	V _{SS}					V _{SS}	V _{EXT}	TMS	TCK
B	V _{DD}	DNU ⁴	DQ4	V _{SSQ}					V _{SSQ}	DQ0	DNU ⁴	V _{DD}
C	V _{TT}	DNU ⁴	DQ5	V _{DDQ}					V _{DDQ}	DQ1	DNU ⁴	V _{TT}
D	A22 ¹	DNU ⁴	DQ6	V _{SSQ}					V _{SSQ}	QK0#	QK0	V _{SS}
E	A21 ²	DNU ⁴	DQ7	V _{DDQ}					V _{DDQ}	DQ2	DNU ⁴	A20 ²
F	A5	DNU ⁴	DQ8	V _{SSQ}					V _{SSQ}	DQ3	DNU ⁴	QVLD
G	A8	A6	A7	V _{DD}					V _{DD}	A2	A1	A0
H	B2	A9	V _{SS}	V _{SS}					V _{SS}	V _{SS}	A4	A3
J	NF ³	NF ³	V _{DD}	V _{DD}					V _{DD}	V _{DD}	B0	CK
K	DK	DK#	V _{DD}	V _{DD}					V _{DD}	V _{DD}	B1	CK#
L	REF#	CS#	V _{SS}	V _{SS}					V _{SS}	V _{SS}	A14	A13
M	WE#	A16	A17	V _{DD}					V _{DD}	A12	A11	A10
N	A18	DNU ⁴	DQ14	V _{SSQ}					V _{SSQ}	DQ9	DNU ⁴	A19
P	A15	DNU ⁴	DQ15	V _{DDQ}					V _{DDQ}	DQ10	DNU ⁴	DM
R	V _{SS}	QK1	QK1#	V _{SSQ}					V _{SSQ}	DQ11	DNU ⁴	V _{SS}
T	V _{TT}	DNU ⁴	DQ16	V _{DDQ}					V _{DDQ}	DQ12	DNU ⁴	V _{TT}
U	V _{DD}	DNU ⁴	DQ17	V _{SSQ}					V _{SSQ}	DQ13	DNU ⁴	V _{DD}
V	V _{REF}	ZQ	V _{EXT}	V _{SS}					V _{SS}	V _{EXT}	TDO	TDI

- Notes:
1. Reserved for future use. This may optionally be connected to GND.
 2. Reserved for future use. This signal is internally connected and has parasitic characteristics of an address input signal. This may optionally be connected to GND.
 3. No function. This signal is internally connected and has parasitic characteristics of a clock input signal. This may optionally be connected to GND.
 4. Do not use. This signal is internally connected and has parasitic characteristics of a I/O. This may optionally be connected to GND. Note that if ODT is enabled on Rev. A die, these pins will be connected to V_{TT}. The DNU pins are High-Z on Rev. B die when ODT is enabled.

Table 3: 8 Meg x 36 Ball Assignments (Top View)

	1	2	3	4	5	6	7	8	9	10	11	12
A	V _{REF}	V _{SS}	V _{EXT}	V _{SS}					V _{SS}	V _{EXT}	TMS	TCK
B	V _{DD}	DQ8	DQ9	V _{SSQ}					V _{SSQ}	DQ1	DQ0	V _{DD}
C	V _{TT}	DQ10	DQ11	V _{DDQ}					V _{DDQ}	DQ3	DQ2	V _{TT}
D	A22	DQ12	DQ13	V _{SSQ}					V _{SSQ}	QK0#	QK0	V _{SS}
E	A21 ²	DQ14	DQ15	V _{DDQ}					V _{DDQ}	DQ5	DQ4	A20 ²
F	A5	DQ16	DQ17	V _{SSQ}					V _{SSQ}	DQ7	DQ6	QVLD
G	A8	A6	A7	V _{DD}					V _{DD}	A2	A1	A0
H	B2	A9	V _{SS}	V _{SS}					V _{SS}	V _{SS}	A4	A3
J	DK0	DK0#	V _{DD}	V _{DD}					V _{DD}	V _{DD}	B0	CK
K	DK1	DK1#	V _{DD}	V _{DD}					V _{DD}	V _{DD}	B1	CK#
L	REF#	CS#	V _{SS}	V _{SS}					V _{SS}	V _{SS}	A14	A13
M	WE#	A16	A17	V _{DD}					V _{DD}	A12	A11	A10
N	A18	DQ24	DQ25	V _{SSQ}					V _{SSQ}	DQ35	DQ34	A19 ²
P	A15	DQ22	DQ23	V _{DDQ}					V _{DDQ}	DQ33	DQ32	DM
R	V _{SS}	QK1	QK1#	V _{SSQ}					V _{SSQ}	DQ31	DQ30	V _{SS}
T	V _{TT}	DQ20	DQ21	V _{DDQ}					V _{DDQ}	DQ29	DQ28	V _{TT}
U	V _{DD}	DQ18	DQ19	V _{SSQ}					V _{SSQ}	DQ27	DQ26	V _{DD}
V	V _{REF}	ZQ	V _{EXT}	V _{SS}					V _{SS}	V _{EXT}	TDO	TDI

- Notes:
1. Reserved for future use. This may optionally be connected to GND.
 2. Reserved for future use. This signal is internally connected and has parasitic characteristics of an address input signal. This may optionally be connected to GND.

Table 4: Ball Descriptions

Symbol	Type	Description
A0–A20	Input	Address inputs: A0–A20 define the row and column addresses for READ and WRITE operations. During a MODE REGISTER SET, the address inputs define the register settings. They are sampled at the rising edge of CK.
BA0–BA2	Input	Bank address inputs: Select to which internal bank a command is being applied.
CK, CK#	Input	Input clock: CK and CK# are differential input clocks. Addresses and commands are latched on the rising edge of CK. CK# is ideally 180 degrees out of phase with CK.
CS#	Input	Chip select: CS# enables the command decoder when LOW and disables it when HIGH. When the command decoder is disabled, new commands are ignored, but internal operations continue.
DK, DK#	Input	Input data clock: DK and DK# are the differential input data clocks. All input data is referenced to both edges of DK. DK# is ideally 180 degrees out of phase with DK. For the x36 device, DQ0–DQ17 are referenced to DK0 and DK0# and DQ18–DQ35 are referenced to DK1 and DK1#. For the x9 and x18 devices, all DQs are referenced to DK and DK#. All DKx and DKx# pins must always be supplied to the device.
DM	Input	Input data mask: The DM signal is the input mask signal for WRITE data. Input data is masked when DM is sampled HIGH. DM is sampled on both edges of DK (DK1 for the x36 configuration). Tie signal to ground if not used.
TCK	Input	IEEE 1149.1 clock input: This ball must be tied to V _{SS} if the JTAG function is not used.
TMS, TDI	Input	IEEE 1149.1 test inputs: These balls may be left as no connects if the JTAG function is not used.
WE#, REF#	Input	Command inputs: Sampled at the positive edge of CK, WE# and REF# define (together with CS#) the command to be executed.
DQ0–DQ35	I/O	Data input: The DQ signals form the 36-bit data bus. During READ commands, the data is referenced to both edges of QKx. During WRITE commands, the data is sampled at both edges of DK.
ZQ	Reference	External impedance (25–60Ω): This signal is used to tune the device outputs to the system data bus impedance. DQ output impedance is set to 0.2 × RQ, where RQ is a resistor from this signal to ground. Connecting ZQ to GND invokes the minimum impedance mode. Connecting ZQ to V _{DD} invokes the maximum impedance mode. Refer to the Mode Register Definition in Nonmultiplexed Address Mode figure to activate this function.
QKx, QKx#	Output	Output data clocks: QKx and QKx# are opposite polarity, output data clocks. They are free-running, and during READs, are edge-aligned with data output from the RLD RAM. QKx# is ideally 180 degrees out of phase with QKx. For the x36 device, QK0 and QK0# are aligned with DQ0–DQ17, and QK1 and QK1# are aligned with DQ18–DQ35. For the x18 device, QK0 and QK0# are aligned with DQ0–DQ8, while QK1 and QK1# are aligned with Q9–Q17. For the x9 device, all DQs are aligned with QK0 and QK0#.
QVLD	Output	Data valid: The QVLD pin indicates valid output data. QVLD is edge-aligned with QKx and QKx#.
TDO	Output	IEEE 1149.1 test output: JTAG output. This ball may be left as no connect if the JTAG function is not used.
V _{DD}	Supply	Power supply: Nominally, 1.8V. See the DC Electrical Characteristics and Operating Conditions table for range.
V _{DDQ}	Supply	DQ power supply: Nominally, 1.5V or 1.8V. Isolated on the device for improved noise immunity. See the DC Electrical Characteristics and Operating Conditions table for range.
V _{EXT}	Supply	Power supply: Nominally, 2.5V. See the DC Electrical Characteristics and Operating Conditions table for range.

Table 4: Ball Descriptions (Continued)

Symbol	Type	Description
V _{REF}	Supply	Input reference voltage: Nominally V _{DDQ} /2. Provides a reference voltage for the input buffers.
V _{SS}	Supply	Ground.
V _{SSQ}	Supply	DQ ground: Isolated on the device for improved noise immunity.
V _{TT}	Supply	Power supply: Isolated termination supply. Nominally, V _{DDQ} /2. See the DC Electrical Characteristics and Operating Conditions table for range.
A21	–	Reserved for future use: This signal is internally connected and can be treated as an address input.
A22	–	Reserved for future use: This signal is not connected and can be connected to ground.
DNU	–	Do not use: These balls may be connected to ground. Note that if ODT is enabled on Rev. A die, these pins will be connected to V _{TT} . The DNU pins are High-Z on Rev. B die when ODT is enabled.
NF	–	No function: These balls can be connected to ground.

Package Dimensions

Figure 6: 144-Ball μ BGA

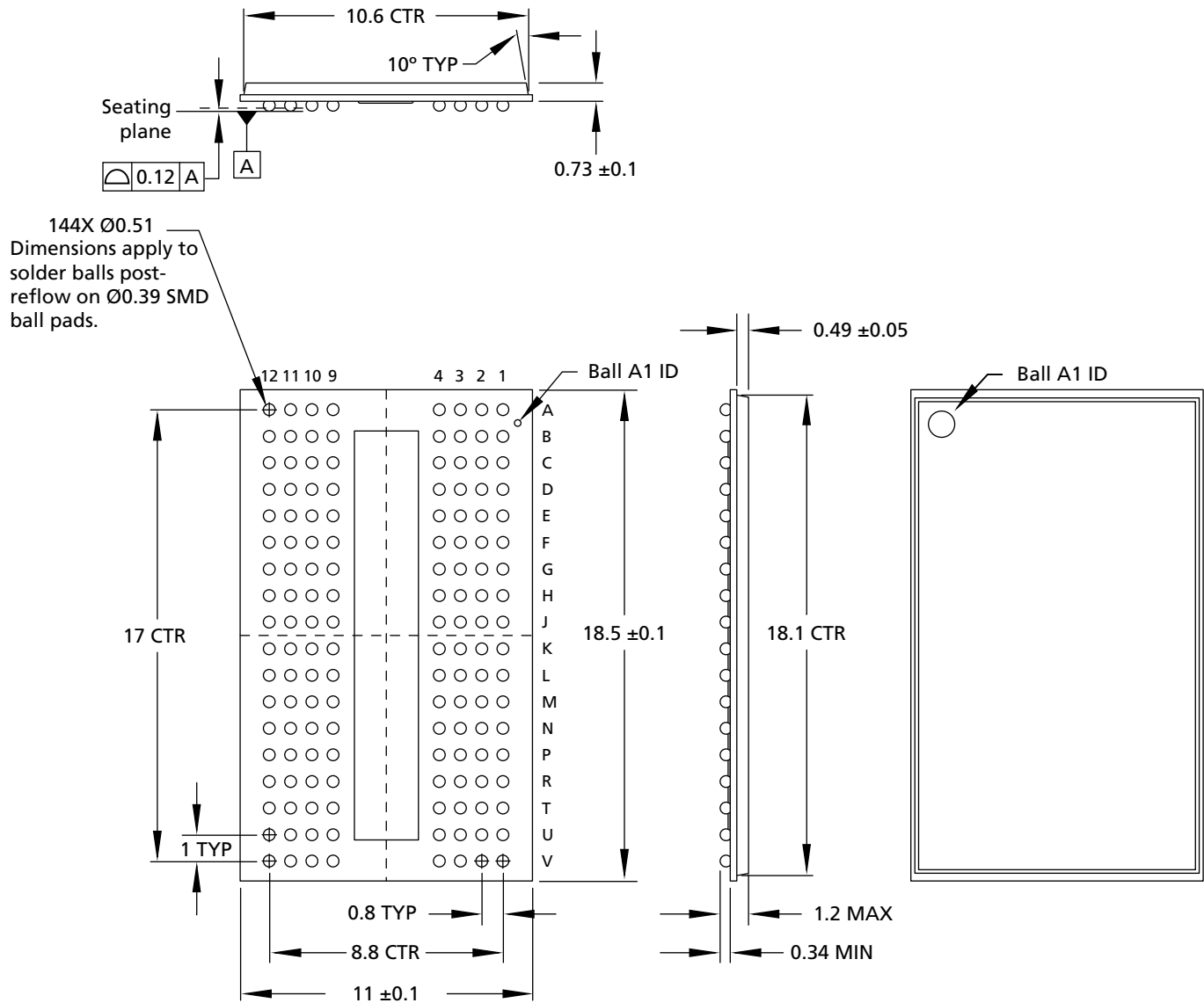

- Notes:
1. All dimensions are in millimeters.
 2. Solder Ball Material:
SAC305 (96.5% Sn, 3% Ag, 0.5% Cu) or
Eutectic (62% Sn, 36% Pb, 2% Ag)

Figure 7: 144-Ball FBGA

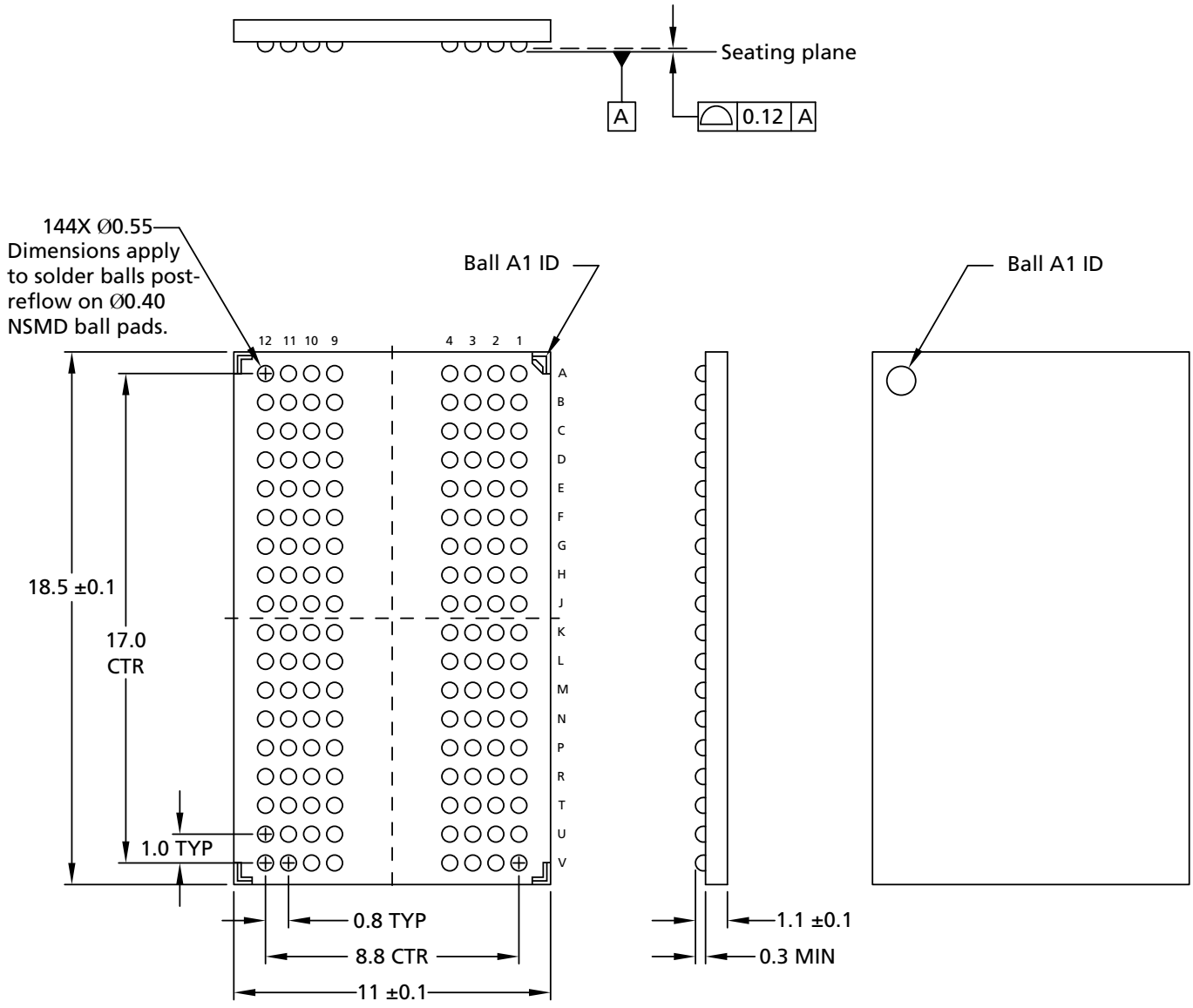

- Notes: 1. All dimensions are in millimeters.
2. Solder ball material: SAC302 (96.8% Sn, 3% Ag, 0.2% Cu).

Electrical Specifications – I_{DD}

Table 5: I_{DD} Operating Conditions and Maximum Limits – Rev. A

Notes appear after Rev. B table

Description	Condition	Symbol	-25	-33	-5	Units
Standby current	t _{CK} = idle; All banks idle; No inputs toggling	I _{SB1} (V _{DD}) x9/x18	48	48	48	mA
		I _{SB1} (V _{DD}) x36	48	48	48	
		I _{SB1} (V _{EXT})	26	26	26	
Active standby current	CS# = 1; No commands; Bank address incremented and half address/data change once every 4 clock cycles	I _{SB2} (V _{DD}) x9/x18	288	233	189	mA
		I _{SB2} (V _{DD}) x36	288	233	189	
		I _{SB2} (V _{EXT})	26	26	26	
Operational current	BL = 2; Sequential bank access; Bank transitions once every t _{RC} ; Half address transitions once every t _{RC} ; Read followed by write sequence; continuous data during WRITE commands	I _{DD1} (V _{DD}) x9/x18	348	305	255	mA
		I _{DD1} (V _{DD}) x36	374	343	292	
		I _{DD1} (V _{EXT})	41	36	36	
Operational current	BL = 4; Sequential bank access; Bank transitions once every t _{RC} ; Half address transitions once every t _{RC} ; Read followed by write sequence; Continuous data during WRITE commands	I _{DD2} (V _{DD}) x9/x18	362	319	269	mA
		I _{DD2} (V _{DD}) x36	418	389	339	
		I _{DD2} (V _{EXT})	48	42	42	
Operational current	BL = 8; Sequential bank access; Bank transitions once every t _{RC} ; half address transitions once every t _{RC} ; Read followed by write sequence; continuous data during WRITE commands	I _{DD3} (V _{DD}) x9/x18	408	368	286	mA
		I _{DD3} (V _{DD}) x36	n/a	n/a	n/a	
		I _{DD3} (V _{EXT})	55	48	48	
Burst refresh current	Eight-bank cyclic refresh; Continuous address/data; Command bus remains in refresh for all eight banks	I _{REF1} (V _{DD}) x9/x18	785	615	430	mA
		I _{REF1} (V _{DD}) x36	785	615	430	
		I _{REF1} (V _{EXT})	133	111	105	
Distributed refresh current	Single-bank refresh; Sequential bank access; Half address transitions once every t _{RC} , continuous data	I _{REF2} (V _{DD}) x9/x18	325	267	221	mA
		I _{REF2} (V _{DD}) x36	326	281	227	
		I _{REF2} (V _{EXT})	48	42	42	
Operating burst write current example	BL = 2; Cyclic bank access; Half of address bits change every clock cycle; Continuous data; measurement is taken during continuous WRITE	I _{DD2W} (V _{DD}) x9/x18	970	819	597	mA
		I _{DD2W} (V _{DD}) x36	990	914	676	
		I _{DD2W} (V _{EXT})	100	90	69	
Operating burst write current example	BL = 4; Cyclic bank access; Half of address bits change every 2 clock cycles; Continuous data; Measurement is taken during continuous WRITE	I _{DD4W} (V _{DD}) x9/x18	779	609	439	mA
		I _{DD4W} (V _{DD}) x36	882	790	567	
		I _{DD4W} (V _{EXT})	88	77	63	
Operating burst write current example	BL = 8; Cyclic bank access; Half of address bits change every 4 clock cycles; continuous data; Measurement is taken during continuous WRITE	I _{DD8W} (V _{DD}) x9/x18	668	525	364	mA
		I _{DD8W} (V _{DD}) x36	n/a	n/a	n/a	
		I _{DD8W} (V _{EXT})	60	51	40	



Table 5: I_{DD} Operating Conditions and Maximum Limits – Rev. A (Continued)

Notes appear after Rev. B table

Description	Condition	Symbol	-25	-33	-5	Units
Operating burst read current example	BL = 2; Cyclic bank access; Half of address bits change every clock cycle; Measurement is taken during continuous READ	I _{DD2R} (V _{DD}) x9/x18	860	735	525	mA
		I _{DD2R} (V _{DD}) x36	880	795	565	
		I _{DD2R} (V _{EXT})	100	90	69	
Operating burst read current example	BL = 4; Cyclic bank access; Half of address bits change every 2 clock cycles; Measurement is taken during continuous READ	I _{DD4R} (V _{DD}) x9/x18	680	525	380	mA
		I _{DD4R} (V _{DD}) x36	730	660	455	
		I _{DD4R} (V _{EXT})	88	77	63	
Operating burst read current example	BL = 8; Cyclic bank access; Half of address bits change every 4 clock cycles; Measurement is taken during continuous READ	I _{DD8R} (V _{DD}) x9/x18	570	450	310	mA
		I _{DD8R} (V _{DD}) x36	n/a	n/a	n/a	
		I _{DD8R} (V _{EXT})	60	51	40	

Table 6: I_{DD} Operating Conditions and Maximum Limits – Rev. B

Notes appear below this table.

Description	Condition	Symbol	-18	-25E	-25	-33	Units
Standby current	t ^{CK} = idle; All banks idle; No inputs toggling	I _{SB1} (V _{DD}) x9/x18	55	55	55	55	mA
		I _{SB1} (V _{DD}) x36	55	55	55	55	
		I _{SB1} (V _{EXT})	5	5	5	5	
Active standby current	CS# = 1; No commands; Bank address incremented and half address/data change once every 4 clock cycles	I _{SB2} (V _{DD}) x9/x18	250	215	215	190	mA
		I _{SB2} (V _{DD}) x36	250	215	215	190	
		I _{SB2} (V _{EXT})	5	5	5	5	
Operational current	BL = 2; Sequential bank access; Bank transitions once every t ^{RC} ; Half address transitions once every t ^{RC} ; Read followed by write sequence; continuous data during WRITE commands	I _{DD1} (V _{DD}) x9/x18	310	285	260	225	mA
		I _{DD1} (V _{DD}) x36	320	295	270	230	
		I _{DD1} (V _{EXT})	10	10	10	10	
Operational current	BL = 4; Sequential bank access; Bank transitions once every t ^{RC} ; Half address transitions once every t ^{RC} ; Read followed by write sequence; Continuous data during WRITE commands	I _{DD2} (V _{DD}) x9/x18	315	290	260	220	mA
		I _{DD2} (V _{DD}) x36	330	305	275	230	
		I _{DD2} (V _{EXT})	10	10	10	10	
Operational current	BL = 8; Sequential bank access; Bank transitions once every t ^{RC} ; half address transitions once every t ^{RC} ; Read followed by write sequence; continuous data during WRITE commands	I _{DD3} (V _{DD}) x9/x18	330	305	275	230	mA
		I _{DD3} (V _{DD}) x36	390	365	320	265	
		I _{DD3} (V _{EXT})	15	15	15	15	
Burst refresh current	Eight-bank cyclic refresh; Continuous address/data; Command bus remains in refresh for all eight banks	I _{REF1} (V _{DD}) x9/x18	660	540	530	430	mA
		I _{REF1} (V _{DD}) x36	670	545	535	435	
		I _{REF1} (V _{EXT})	45	30	30	25	
Distributed refresh current	Single-bank refresh; Sequential bank access; Half address transitions once every t ^{RC} , continuous data	I _{REF2} (V _{DD}) x9/x18	295	265	250	215	mA
		I _{REF2} (V _{DD}) x36	295	265	250	215	
		I _{REF2} (V _{EXT})	10	10	10	10	
Operating burst write current example	BL = 2; Cyclic bank access; Half of address bits change every clock cycle; Continuous data; measurement is taken during continuous WRITE	I _{DD2W} (V _{DD}) x9/x18	830	655	655	530	mA
		I _{DD2W} (V _{DD}) x36	885	700	700	565	
		I _{DD2W} (V _{EXT})	40	35	35	30	
Operating burst write current example	BL = 4; Cyclic bank access; Half of address bits change every 2 clock cycles; Continuous data; Measurement is taken during continuous WRITE	I _{DD4W} (V _{DD}) x9/x18	580	465	465	385	mA
		I _{DD4W} (V _{DD}) x36	635	510	510	420	
		I _{DD4W} (V _{EXT})	25	20	20	20	
Operating burst write current example	BL = 8; Cyclic bank access; Half of address bits change every 4 clock cycles; continuous data; Measurement is taken during continuous WRITE	I _{DD8W} (V _{DD}) x9/x18	445	370	370	305	mA
		I _{DD8W} (V _{DD}) x36	560	455	455	375	
		I _{DD8W} (V _{EXT})	25	20	20	20	

Table 6: I_{DD} Operating Conditions and Maximum Limits – Rev. B (Continued)

Notes appear below this table.

Description	Condition	Symbol	-18	-25E	-25	-33	Units
Operating burst read current example	BL = 2; Cyclic bank access; Half of address bits change every clock cycle; Measurement is taken during continuous READ	I _{DD2R} (V _{DD}) x9/x18	805	640	640	515	mA
		I _{DD2R} (V _{DD}) x36	850	675	675	540	
		I _{DD2R} (V _{EXT})	40	35	35	30	
Operating burst read current example	BL = 4; Cyclic bank access; Half of address bits change every 2 clock cycles; Measurement is taken during continuous READ	I _{DD4R} (V _{DD}) x9/x18	545	440	440	365	mA
		I _{DD4R} (V _{DD}) x36	590	475	475	390	
		I _{DD4R} (V _{EXT})	25	20	20	20	
Operating burst read current example	BL = 8; Cyclic bank access; Half of address bits change every 4 clock cycles; Measurement is taken during continuous READ	I _{DD8R} (V _{DD}) x9/x18	410	335	335	280	mA
		I _{DD8R} (V _{DD}) x36	525	425	425	350	
		I _{DD8R} (V _{EXT})	25	20	20	20	

- Notes:
- I_{DD} specifications are tested after the device is properly initialized. +0°C ≤ T_c ≤ +95°C; +1.7V ≤ V_{DD} ≤ +1.9V, +2.38V ≤ V_{EXT} ≤ +2.63V, +1.4V ≤ V_{DDQ} ≤ V_{DD}, V_{REF} = V_{DDQ}/2.
 - t_{CK} = t_{DK} = MIN, t_{RC} = MIN.
 - Input slew rate is specified in Table 9 (page 23).
 - Definitions for I_{DD} conditions:
 - LOW is defined as V_{IN} ≤ V_{IL(AC)} MAX.
 - HIGH is defined as V_{IN} ≥ V_{IH(AC)} MIN.
 - Stable is defined as inputs remaining at a HIGH or LOW level.
 - Floating is defined as inputs at V_{REF} = V_{DDQ}/2.
 - Continuous data is defined as half the DQ signals changing between HIGH and LOW every half clock cycle (twice per clock).
 - Continuous address is defined as half the address signals changing between HIGH and LOW every clock cycle (once per clock).
 - Sequential bank access is defined as the bank address incrementing by one every t_{RC}.
 - Cyclic bank access is defined as the bank address incrementing by one for each command access. For BL = 2 this is every clock, for BL = 4 this is every other clock, and for BL = 8 this is every fourth clock.
 - CS# is HIGH unless a READ, WRITE, AREF, or MRS command is registered. CS# never transitions more than once per clock cycle.
 - I_{DD} parameters are specified with ODT disabled.
 - Tests for AC timing, I_{DD}, and electrical AC and DC characteristics may be conducted at nominal reference/supply voltage levels, but the related specifications and device operations are tested for the full voltage range specified.
 - I_{DD} tests may use a V_{IL}-to-V_{IH} swing of up to 1.5V in the test environment, but input timing is still referenced to V_{REF} (or to the crossing point for CK/CK#), and parameter specifications are tested for the specified AC input levels under normal use conditions. The minimum slew rate for the input signals used to test the device is 2 V/ns in the range between V_{IL(AC)} and V_{IH(AC)}.

Absolute Maximum Ratings

Stresses greater than those listed in the Absolute Maximum Ratings table may cause permanent damage to the device. This is a stress rating only, and functional operation of the device at these or any other conditions outside those indicated in the operational sections of this specification is not implied. Exposure to absolute maximum rating conditions for extended periods may affect reliability.

Table 7: Absolute Maximum Ratings

Parameter	Min	Max	Units
I/O voltage	-0.3	$V_{DDQ} + 0.3$	V
Voltage on V_{EXT} supply relative to V_{SS}	-0.3	+2.8	V
Voltage on V_{DD} supply relative to V_{SS}	-0.3	+2.1	V
Voltage on V_{DDQ} supply relative to V_{SS}	-0.3	+2.1	V

AC and DC Operating Conditions

Table 8: DC Electrical Characteristics and Operating Conditions

Note 1 applies to entire table; unless otherwise noted: $+0^{\circ}\text{C} \leq T_C \leq +95^{\circ}\text{C}$; $+1.7\text{V} \leq V_{DD} \leq +1.9\text{V}$

Description	Conditions	Symbol	Min	Max	Units	Notes
Supply voltage	-	V_{EXT}	2.38	2.63	V	
Supply voltage	-	V_{DD}	1.7	1.9	V	2
Isolated output buffer supply	-	V_{DDQ}	1.4	V_{DD}	V	2, 3
Reference voltage	-	V_{REF}	$0.49 \times V_{DDQ}$	$0.51 \times V_{DDQ}$	V	4, 5, 6
Termination voltage	-	V_{TT}	$0.95 \times V_{REF}$	$1.05 \times V_{REF}$	V	7, 8
Input high (logic 1) voltage	-	V_{IH}	$V_{REF} + 0.1$	$V_{DDQ} + 0.3$	V	2
Input low (logic 0) voltage	-	V_{IL}	$V_{SSQ} - 0.3$	$V_{REF} - 0.1$	V	2
Output high current	$V_{OH} = V_{DDQ}/2$	I_{OH}	$(V_{DDQ}/2)/(1.15 \times RQ/5)$	$(V_{DDQ}/2)/(0.85 \times RQ/5)$	A	9, 10, 11
Output low current	$V_{OL} = V_{DDQ}/2$	I_{OL}	$(V_{DDQ}/2)/(1.15 \times RQ/5)$	$(V_{DDQ}/2)/(0.85 \times RQ/5)$	A	9, 10, 11
Clock input leakage current	$0\text{V} \leq V_{IN} \leq V_{DD}$	I_{LC}	-5	5	μA	
Input leakage current	$0\text{V} \leq V_{IN} \leq V_{DD}$	I_{LI}	-5	5	μA	
Output leakage current	$0\text{V} \leq V_{IN} \leq V_{DDQ}$	I_{LO}	-5	5	μA	
Reference voltage current	-	I_{REF}	-5	5	μA	

- Notes:
1. All voltages referenced to V_{SS} (GND).
 2. Overshoot: $V_{IH(AC)} \leq V_{DD} + 0.7\text{V}$ for $t \leq t_{CK}/2$. Undershoot: $V_{IL(AC)} \geq -0.5\text{V}$ for $t \leq t_{CK}/2$. During normal operation, V_{DDQ} must not exceed V_{DD} . Control input signals may not have pulse widths less than $t_{CK}/2$ or operate at frequencies exceeding t_{CK} (MAX).
 3. V_{DDQ} can be set to a nominal $1.5\text{V} \pm 0.1\text{V}$ or $1.8\text{V} \pm 0.1\text{V}$ supply.
 4. Typically the value of V_{REF} is expected to be $0.5 \times V_{DDQ}$ of the transmitting device. V_{REF} is expected to track variations in V_{DDQ} .
 5. Peak-to-peak AC noise on V_{REF} must not exceed $\pm 2\% V_{REF(DC)}$.

6. V_{REF} is expected to equal $V_{DDQ}/2$ of the transmitting device and to track variations in the DC level of the same. Peak-to-peak noise (non-common mode) on V_{REF} may not exceed $\pm 2\%$ of the DC value. Thus, from $V_{DDQ}/2$, V_{REF} is allowed $\pm 2\% V_{DDQ}/2$ for DC error and an additional $\pm 2\% V_{DDQ}/2$ for AC noise. This measurement is to be taken at the nearest V_{REF} bypass capacitor.
7. V_{TT} is expected to be set equal to V_{REF} and must track variations in the DC level of V_{REF} .
8. On-die termination may be selected using mode register bit 9 (see Mode Register Definition in Nonmultiplexed Address Mode). A resistance R_{TT} from each data input signal to the nearest V_{TT} can be enabled.
 $R_{TT} = 125\text{--}185\Omega$ at $95^\circ\text{C } T_C$.
9. I_{OH} and I_{OL} are defined as absolute values and are measured at $V_{DDQ}/2$. I_{OH} flows from the device, I_{OL} flows into the device.
10. If MRS bit A8 is 0, use $R_Q = 250\Omega$ in the equation in lieu of presence of an external impedance matched resistor.
11. For V_{OL} and V_{OH} , refer to the device HSPICE or IBIS driver models.

Table 9: Input AC Logic Levels

 Notes 1–3 apply to entire table; unless otherwise noted: $+0^\circ\text{C} \leq T_C \leq +95^\circ\text{C}$; $+1.7\text{V} \leq V_{DD} \leq +1.9\text{V}$

Description	Symbol	Min	Max	Units
Input high (logic 1) voltage	V_{IH}	$V_{REF} + 0.2$	–	V
Input low (logic 0) voltage	V_{IL}	–	$V_{REF} - 0.2$	V

- Notes:
1. All voltages referenced to V_{SS} (GND).
 2. The AC and DC input level specifications are as defined in the HSTL standard (that is, the receiver will effectively switch as a result of the signal crossing the AC input level and will remain in that state as long as the signal does not ring back above [below] the DC input LOW [HIGH] level).
 3. The minimum slew rate for the input signals used to test the device is 2 V/ns in the range between $V_{IL(AC)}$ and $V_{IH(AC)}$ (see Minimum Slew Rate figure below).

Figure 8: Minimum Slew Rate

Table 10: Differential Input Clock Operating Conditions

Notes 1–4 apply to entire table; unless otherwise noted: $+0^{\circ}\text{C} \leq T_C \leq +95^{\circ}\text{C}$; $+1.7\text{V} \leq V_{DD} \leq +1.9\text{V}$

Parameter/Condition	Symbol	Min	Max	Units	Notes
Clock input voltage level: CK and CK#	$V_{IN(DC)}$	-0.3	$V_{DDQ} + 0.3$	V	
Clock input differential voltage: CK and CK#	$V_{ID(DC)}$	0.2	$V_{DDQ} + 0.6$	V	5
Clock input differential voltage: CK and CK#	$V_{ID(AC)}$	0.4	$V_{DDQ} + 0.6$	V	5
Clock input crossing point voltage: CK and CK#	$V_{IX(AC)}$	$V_{DDQ}/2 - 0.15$	$V_{DDQ}/2 + 0.15$	V	6

- Notes:
1. DKx and DKx# have the same requirements as CK and CK#.
 2. All voltages referenced to V_{SS} (GND).
 3. The CK/CK# input reference level (for timing referenced to CK/CK#) is the point at which CK and CK# cross. The input reference level for signals other than CK/CK# is V_{REF} .
 4. CK and CK# input slew rate must be ≥ 2 V/ns (≥ 4 V/ns if measured differentially).
 5. V_{ID} is the magnitude of the difference between the input level on CK and the input level on CK#.
 6. The value of V_{IX} is expected to equal $V_{DDQ}/2$ of the transmitting device and must track variations in the DC level of the same.

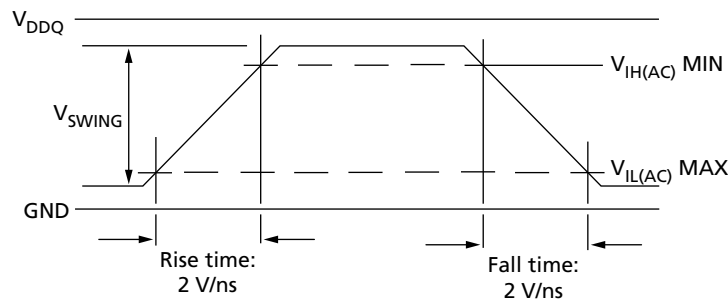
Figure 9: Clock Input

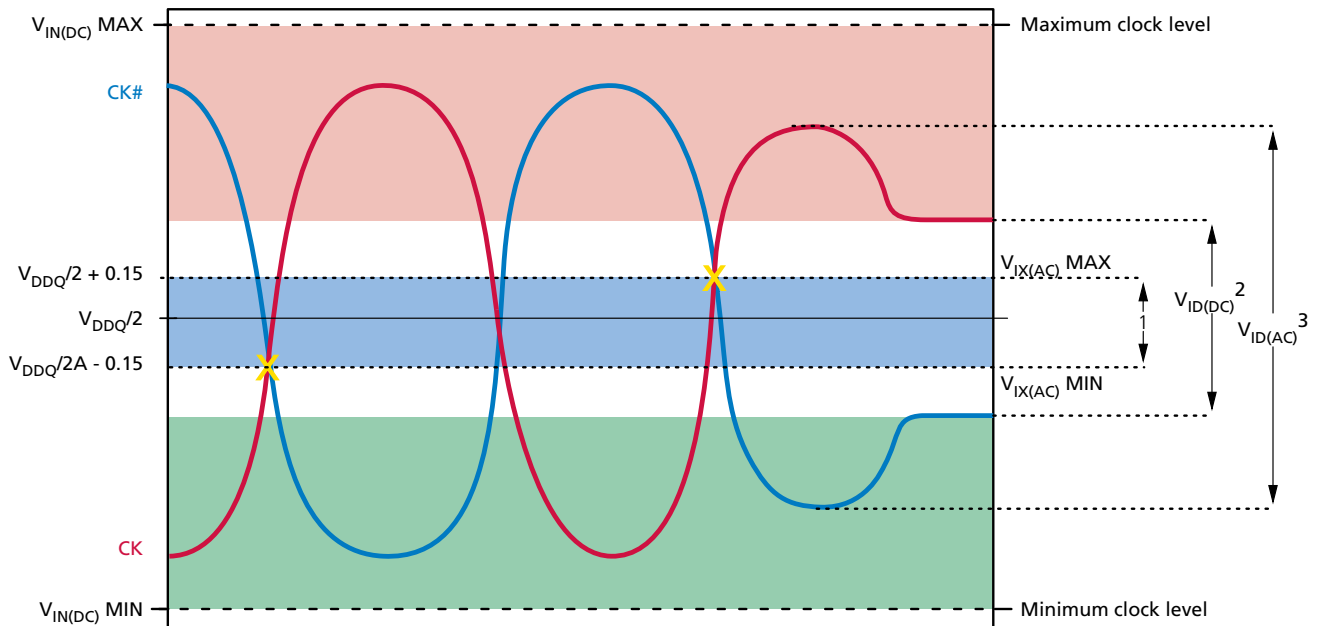

- Notes:
1. CK and CK# must cross within this region.
 2. CK and CK# must meet at least $V_{ID(DC)}$ MIN when static and centered around $V_{DDQ}/2$.
 3. Minimum peak-to-peak swing.
 4. It is a violation to tristate CK and CK# after the part is initialized.

Input Slew Rate Derating

Note: The following description also pertains to data setup and hold derating when CK/CK# are replaced with DK/DK#.

The Address and Command Setup and Hold Derating Values table and the Data Setup and Hold Derating Values table below define the address, command, and data setup and hold derating values. These values are added to the default $t_{AS}/t_{CS}/t_{DS}$ and $t_{AH}/t_{CH}/t_{DH}$ specifications when the slew rate of any of these input signals is less than the 2 V/ns the nominal setup and hold specifications are based upon.

To determine the setup and hold time needed for a given slew rate, add the t_{AS}/t_{CS} default specification to the “ $t_{AS}/t_{CS} V_{REF}$ to CK/CK# Crossing” and the t_{AH}/t_{CH} default specification to the “ t_{AH}/t_{CH} CK/CK# Crossing to V_{REF} ” derated values on the Address and Command Setup and Hold Derating Values table. The derated data setup and hold values can be determined in a like manner using the “ $t_{DS} V_{REF}$ to CK/CK# Crossing” and “ t_{DH} to CK/CK# Crossing to V_{REF} ” values on the Data Setup and Hold Derating Values table. The derating values on the Address and Command Setup and Hold Derating Values table and the Data Setup and Hold Derating Values table apply to all speed grades.

The setup times on the Address and Command Setup and Hold Derating Values table and the Data Setup and Hold Derating Values table represent a rising signal. In this case, the time from which the rising signal crosses $V_{IH(AC)}$ MIN to the CK/CK# cross point is static and must be maintained across all slew rates. The derated setup timing represents the point at which the rising signal crosses $V_{REF(DC)}$ to the CK/CK# cross point. This derated value is calculated by determining the time needed to maintain the given slew rate and the delta between $V_{IH(AC)}$ MIN and the CK/CK# cross point. The setup values in the Address and Command Setup and Hold Derating Values table and the Data Setup and Hold Derating Values table are also valid for falling signals (with respect to $V_{IL(AC)}$ MAX and the CK/CK# cross point).

The hold times in the Address and Command Setup and Hold Derating Values table and the Data Setup and Hold Derating Values table represent falling signals. In this case, the time from the CK/CK# cross point to when the signal crosses $V_{IH(DC)}$ MIN is static and must be maintained across all slew rates. The derated hold timing represents the delta between the CK/CK# cross point to when the falling signal crosses $V_{REF(DC)}$. This derated value is calculated by determining the time needed to maintain the given slew rate and the delta between the CK/CK# cross point and $V_{IH(DC)}$. The hold values in the Address and Command Setup and Hold Derating Values table and the Data Setup and Hold Derating Values table are also valid for rising signals (with respect to $V_{IL(DC)}$ MAX and the CK and CK# cross point).

Table 11: Address and Command Setup and Hold Derating Values

Command/Address Slew Rate (V/ns)	$t_{AS}/t_{CS} V_{REF}$ to CK/CK# Crossing	$t_{AS}/t_{CS} V_{IH(AC)}$ MIN to CK/CK# Crossing	t_{AH}/t_{CH} CK/CK# Crossing to V_{REF}	t_{AH}/t_{CH} CK/CK# Crossing to $V_{IH(DC)}$ MIN	Units
CK, CK# Differential Slew Rate: 2.0 V/ns					
2.0	0	-100	0	-50	ps
1.9	5	-100	3	-50	ps
1.8	11	-100	6	-50	ps



Table 11: Address and Command Setup and Hold Derating Values (Continued)

Command/Address Slew Rate (V/ns)	t_{AS}^{AS}/t_{CS}^{CS} V_{REF} to CK/CK# Crossing	t_{AS}^{AS}/t_{CS}^{CS} $V_{IH(AC)}$ MIN to CK/CK# Crossing	t_{AH}^{AH}/t_{CH}^{CH} CK/CK# Crossing to V_{REF}	t_{AH}^{AH}/t_{CH}^{CH} CK/CK# Crossing to $V_{IH(DC)}$ MIN	Units
1.7	18	-100	9	-50	ps
1.6	25	-100	13	-50	ps
1.5	33	-100	17	-50	ps
1.4	43	-100	22	-50	ps
1.3	54	-100	27	-50	ps
1.2	67	-100	34	-50	ps
1.1	82	-100	41	-50	ps
1.0	100	-100	50	-50	ps
CK, CK# Differential Slew Rate: 1.5 V/ns					
2.0	30	-70	30	-20	ps
1.9	35	-70	33	-20	ps
1.8	41	-70	36	-20	ps
1.7	48	-70	39	-20	ps
1.6	55	-70	43	-20	ps
1.5	63	-70	47	-20	ps
1.4	73	-70	52	-20	ps
1.3	84	-70	57	-20	ps
1.2	97	-70	64	-20	ps
1.1	112	-70	71	-20	ps
1.0	130	-70	80	-20	ps
CK, CK# Differential Slew Rate: 1.0 V/ns					
2.0	60	-40	60	10	ps
1.9	65	-40	63	10	ps
1.8	71	-40	66	10	ps
1.7	78	-40	69	10	ps
1.6	85	-40	73	10	ps
1.5	93	-40	77	10	ps
1.4	103	-40	82	10	ps
1.3	114	-40	87	10	ps
1.2	127	-40	94	10	ps
1.1	142	-40	101	10	ps
1.0	160	-40	110	10	ps



Table 12: Data Setup and Hold Derating Values

Data Slew Rate (V/ns)	$t_{DS} V_{REF}$ to CK/CK# Crossing	$t_{DS} V_{IH(AC)}$ MIN to CK/CK# Crossing	t_{DH} CK/CK# Crossing to V_{REF}	t_{DH} CK/CK# Crossing to $V_{IH(DC)}$ MIN	Units
DK, DK# Differential Slew Rate: 2.0 V/ns					
2.0	0	-100	0	-50	ps
1.9	5	-100	3	-50	ps
1.8	11	-100	6	-50	ps
1.7	18	-100	9	-50	ps
1.6	25	-100	13	-50	ps
1.5	33	-100	17	-50	ps
1.4	43	-100	22	-50	ps
1.3	54	-100	27	-50	ps
1.2	67	-100	34	-50	ps
1.1	82	-100	41	-50	ps
1.0	100	-100	50	-50	ps
DK, DK# Differential Slew Rate: 1.5 V/ns					
2.0	30	-70	30	-20	ps
1.9	35	-70	33	-20	ps
1.8	41	-70	36	-20	ps
1.7	48	-70	39	-20	ps
1.6	55	-70	43	-20	ps
1.5	63	-70	47	-20	ps
1.4	73	-70	52	-20	ps
1.3	84	-70	57	-20	ps
1.2	97	-70	64	-20	ps
1.1	112	-70	71	-20	ps
1.0	130	-70	80	-20	ps
DK, DK# Differential Slew Rate: 1.0 V/ns					
2.0	60	-40	60	10	ps
1.9	65	-40	63	10	ps
1.8	71	-40	66	10	ps
1.7	78	-40	69	10	ps
1.6	85	-40	73	10	ps
1.5	93	-40	77	10	ps
1.4	103	-40	82	10	ps
1.3	114	-40	87	10	ps
1.2	127	-40	94	10	ps
1.1	142	-40	101	10	ps
1.0	160	-40	110	10	ps

Figure 10: Nominal $t_{AS}/t_{CS}/t_{DS}$ and $t_{AH}/t_{CH}/t_{DH}$ Slew Rate

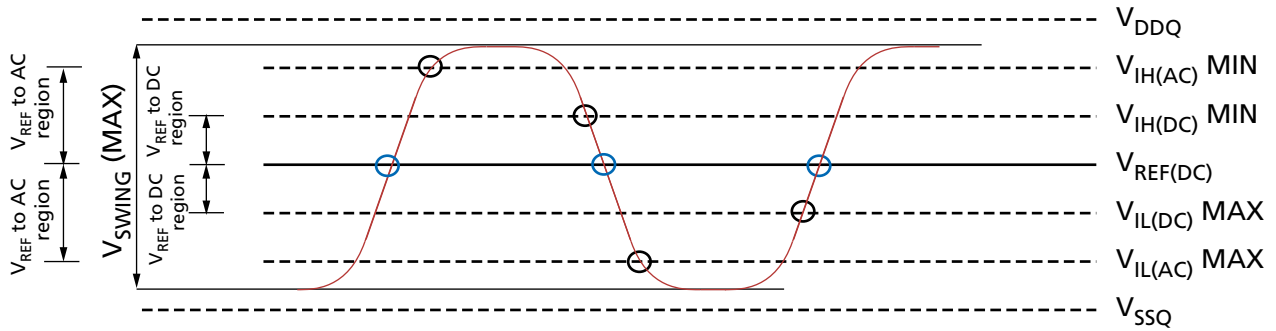

Capacitance

Table 13: Capacitance – μ BGA

Notes 1–2 apply to entire table

Description	Symbol	Conditions	Min	Max	Units
Address/control input capacitance	C_I	$T_A = 25^\circ\text{C}; f = 100 \text{ MHz } V_{DD} = V_{DDQ} = 1.8\text{V}$	1.0	2.0	pF
Input/output capacitance (DQ, DM, and QK/QK#)	C_O		3.0	4.5	pF
Clock capacitance (CK/CK#, and DK/DK#)	C_{CK}		1.5	2.5	pF
JTAG pins	C_{JTAG}		1.5	4.5	pF

- Notes: 1. Capacitance is not tested on ZQ pin.
 2. JTAG pins are tested at 50 MHz.

Table 14: Capacitance – FBGA

Notes 1–2 apply to entire table

Description	Symbol	Conditions	Min	Max	Units
Address/control input capacitance	C_I	$T_A = 25^\circ\text{C}; f = 100 \text{ MHz } V_{DD} = V_{DDQ} = 1.8\text{V}$	1.5	2.5	pF
Input/output capacitance (DQ, DM, and QK/QK#)	C_O		3.5	5.0	pF
Clock capacitance (CK/CK#, and DK/DK#)	C_{CK}		2.0	3.0	pF
JTAG pins	C_{JTAG}		2.0	5.0	pF

- Notes: 1. Capacitance is not tested on ZQ pin.
 2. JTAG pins are tested at 50 MHz.

AC Electrical Characteristics

Table 15: AC Electrical Characteristics

Notes 1–4 apply to the entire table

Description	Symbol	-18		-25E		-25		-33		-5		Units	Notes
		Min	Max	Min	Max	Min	Max	Min	Max	Min	Max		
Clock													
Input clock cycle time	t_{CK}	1.875	5.7	2.5	5.7	2.5	5.7	3.3	5.7	5.0	5.7	ns	
Input data clock cycle time	t_{DK}	t_{CK}		t_{CK}		t_{CK}		t_{CK}		t_{CK}		ns	
Clock jitter: period	t_{JITper}	-100	100	-150	150	-150	150	-200	200	-250	250	ps	5, 6
Clock jitter: cycle-to-cycle	t_{JITcc}		200		300		300		400		500	ps	
Clock HIGH time	t_{CKH}, t_{DKH}	0.45	0.55	0.45	0.55	0.45	0.55	0.45	0.55	0.45	0.55	t_{CK}	
Clock LOW time	t_{CKL}, t_{DKL}	0.45	0.55	0.45	0.55	0.45	0.55	0.45	0.55	0.45	0.55	t_{CK}	
Clock to input data clock	t_{CKDK}	-0.3	0.3	-0.45	0.5	-0.3	0.5	-0.3	1.0	-0.3	1.5	ns	
Mode register set cycle time to any command	t_{MRSC}	6	–	6	–	6	–	6	–	6	–	t_{CK}	
Setup Times													
Address/command and input setup time	t_{AS}/t_{CS}	0.3	–	0.4	–	0.4	–	0.5	–	0.8	–	ns	
Data-in and data mask to DK setup time	t_{DS}	0.17	–	0.25	–	0.25	–	0.3	–	0.4	–	ns	
Hold Times													
Address/command and input hold time	t_{AH}/t_{CH}	0.3	–	0.4	–	0.4	–	0.5	–	0.8	–	ns	

Table 15: AC Electrical Characteristics (Continued)

Notes 1–4 apply to the entire table

Description	Symbol	-18		-25E		-25		-33		-5		Units	Notes
		Min	Max	Min	Max	Min	Max	Min	Max	Min	Max		
Data-in and data mask to DK hold time	^t DH	0.17	–	0.25	–	0.25	–	0.3	–	0.4	–	ns	
Data and Data Strobe													
Output data clock HIGH time	^t QKH	0.9	1.1	0.9	1.1	0.9	1.1	0.9	1.1	0.9	1.1	^t CKH	
Output data clock LOW time	^t QKL	0.9	1.1	0.9	1.1	0.9	1.1	0.9	1.1	0.9	1.1	^t CKL	
Half-clock period	^t QHP	MIN (^t QKH, ^t QKL)	–	MIN (^t QKH, ^t QKL)	–	MIN (^t QKH, ^t QKL)	–	MIN (^t QKH, ^t QKL)	–	MIN (^t QKH, ^t QKL)	–		
QK edge to clock edge skew	^t CKQK	–0.2	0.2	–0.25	0.25	–0.25	0.25	–0.3	0.3	–0.5	0.5	ns	
QK edge to output data edge	^t QKQ0, ^t QKQ1	–0.12	0.12	–0.2	0.2	–0.2	0.2	–0.25	0.25	–0.3	0.3	ns	7
QK edge to any output data edge	^t QKQ	–0.22	0.22	–0.3	0.3	–0.3	0.3	–0.35	0.35	–0.4	0.4	ns	8
QK edge to QVLD	^t QKVLD	–0.22	0.22	–0.3	0.3	–0.3	0.3	–0.35	0.35	–0.4	0.4	ns	
Data valid window	^t DVW	^t QHP - (^t QKQx [MAX] + ^t QKQx [MIN])	–	^t QHP - (^t QKQx [MAX] + ^t QKQx [MIN])	–	^t QHP - (^t QKQx [MAX] + ^t QKQx [MIN])	–	^t QHP - (^t QKQx [MAX] + ^t QKQx [MIN])	–	^t QHP - (^t QKQx [MAX] + ^t QKQx [MIN])	–		
Refresh													
Average periodic refresh interval	^t REFI	–	0.49	–	0.49	–	0.49	–	0.49	–	0.49	μs	9

- Notes:
- All timing parameters shown here are measured relative to the crossing point of CK/CK#, DK/DK# and to the crossing point with V_{REF} of the command, address, and data signals. In addition, outputs are measured with equivalent load as shown here.
 - Outputs measured with equivalent load:

Figure 11: AC Outputs – Equivalent Load

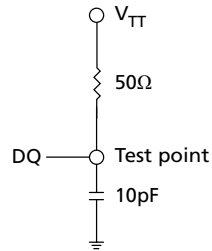

3. Tests for AC timing, I_{DD} , and electrical AC and DC characteristics may be conducted at nominal reference/supply voltage levels, but the related specifications and device operations are tested for the full voltage range specified.
4. AC timing may use a V_{IL} -to- V_{IH} swing of up to 1.5V in the test environment, but input timing is still referenced to V_{REF} (or to the crossing point for CK/CK#), and parameter specifications are tested for the specified AC input levels under normal use conditions. The minimum slew rate for the input signals used to test the device is 2 V/ns in the range between $V_{IL(AC)}$ and $V_{IH(AC)}$.
5. Clock phase jitter is the variance from clock rising edge to the next expected clock rising edge.
6. Frequency drift is not allowed.
7. t_{QKQ0} is referenced to DQ0–DQ17 for the x36 configuration and DQ0–DQ8 for the x18 configuration. t_{QKQ1} is referenced to DQ18–DQ35 for the x36 configuration and DQ9–DQ17 for the x18 configuration.
8. t_{QKQ} takes into account the skew between any QKx and any DQ.
9. To improve efficiency, eight AREF commands (one for each bank) can be posted to the device on consecutive cycles at periodic intervals of 3.90μs.

Temperature and Thermal Impedance

It is imperative that the temperature specifications shown in the Temperature Limits table are maintained to ensure that the junction temperature is in the proper operating range to meet data sheet specifications. An important step in maintaining the proper junction temperature is using the device's thermal impedances correctly. The thermal impedances are listed for the available packages.

Using thermal impedances incorrectly can produce significant errors. Read Micron's TN-00-08: Thermal Applications technical note prior to using the thermal impedances listed in the Temperature Limits table. For designs that are expected to last several years and require the flexibility to use several DRAM die shrinks, consider using final target theta values (rather than existing values) to account for increased thermal impedances from the die size reduction.

The safe junction temperature range can be maintained when the T_C specification is not exceeded. In applications where the device's ambient temperature is too high, the use of forced air and/or heat sinks may be required in order to satisfy the case temperature specifications.

Table 16: Temperature Limits

Parameter		Symbol	Min	Max	Units	Notes
Storage temperature		T_{STG}	-55	+150	°C	1
Reliability junction temperature	Commercial	T_J	-	+110	°C	2
	Industrial		-	+110	°C	2
Operating junction temperature	Commercial	T_J	0	+100	°C	3
	Industrial		-40	+100	°C	3
Operating case temperature	Commercial	T_C	0	+95	°C	4, 5
	Industrial		-40	+95	°C	4, 5, 6

- Notes:
1. Max storage case temperature, T_{STG} , is measured in the center of the package, as shown in the Example Temperature Test Point Location figure. This case temperature limit can be exceeded briefly during package reflow, as noted in Micron's TN-00-15: Recommended Soldering Parameters technical note.
 2. Temperatures greater than 110°C may cause permanent damage to the device. This is a stress rating only and functional operation of the device at or above this is not implied. Exposure to absolute maximum rating conditions for extended periods may affect the reliability of the part.
 3. Junction temperature depends upon package type, cycle time, loading, ambient temperature, and airflow.
 4. MAX operating case temperature; T_C is measured in the center of the package, as shown in the Example Temperature Test Point Location figure.
 5. Device functionality is not guaranteed if the device exceeds maximum T_C during operation.
 6. Both temperature specifications must be satisfied.

Table 17: Thermal Impedance

Package	Substrate	θ_{JA} ($^{\circ}\text{C}/\text{W}$) Airflow = 0m/s	θ_{JA} ($^{\circ}\text{C}/\text{W}$) Airflow = 1m/s	θ_{JA} ($^{\circ}\text{C}/\text{W}$) Airflow = 2m/s	θ_{JB} ($^{\circ}\text{C}/\text{W}$)	θ_{JC} ($^{\circ}\text{C}/\text{W}$)
Rev. A die	2-layer	41.2	29.1	25.3	14.3	2.27
	4-layer	28.2	21.9	19.9	13.6	

Note: 1. Thermal impedance data is based on a number of samples from multiple lots and should be viewed as a typical number.

Table 18: Thermal Impedance

Die Rev.	Package	Substrate	θ_{JA} ($^{\circ}\text{C}/\text{W}$) Airflow = 0m/s	θ_{JA} ($^{\circ}\text{C}/\text{W}$) Airflow = 1m/s	θ_{JA} ($^{\circ}\text{C}/\text{W}$) Airflow = 2m/s	θ_{JB} ($^{\circ}\text{C}/\text{W}$)	θ_{JC} ($^{\circ}\text{C}/\text{W}$)
Rev. B	μ FBGA	Low conductivity	53.7	42.0	37.7	N/A	3.9
		High conductivity	34.1	28.9	27.1	21.9	N/A
	FBGA	Low conductivity	45.3	34.1	30.2	N/A	3.1
		High conductivity	28.2	23.2	21.5	17.3	N/A

Note: 1. Thermal resistance data is based on a number of samples from multiple lots and should be viewed as a typical number.

Figure 12: Example Temperature Test Point Location

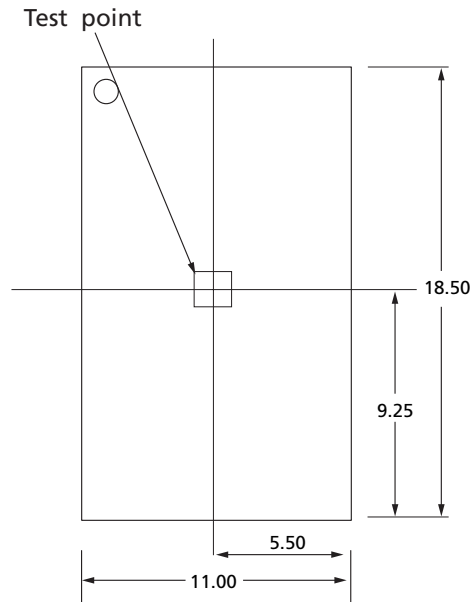

Commands

All input states or sequences not shown are illegal or reserved. All command and address inputs must meet setup and hold times around the rising edge of CK.

Table 19: Description of Commands

Command	Description	Notes
DSEL/NOP	The NOP command is used to perform a no operation to the device, which essentially deselects the chip. Use the NOP command to prevent unwanted commands from being registered during idle or wait states. Operations already in progress are not affected. Output values depend on command history.	1
MRS	The mode register is set via the address inputs A0–A17. See the Mode Register Definition in Nonmultiplexed Address Mode figure for further information. The MRS command can only be issued when all banks are idle and no other operation is in progress.	
READ	The READ command is used to initiate a burst read access to a bank. The value on the BA0–BA2 inputs selects the bank, and the address provided on inputs A0–An selects the data location within the bank.	2
WRITE	The WRITE command is used to initiate a burst write access to a bank. The value on the BA0–BA2 inputs selects the bank, and the address provided on inputs A0–An selects the data location within the bank. Input data appearing on the DQ is written to the memory array subject to the DM input logic level appearing coincident with the data. If the DM signal is registered LOW, the corresponding data will be written to memory. If the DM signal is registered HIGH, the corresponding data inputs will be ignored (that is, this part of the data word will not be written).	2
AUTO RE-FRESH (AREF)	The AREF command is used during normal device operation to refresh the memory content of a bank. The command is nonpersistent, so it must be issued each time a refresh is required. The value on the BA0–BA2 inputs selects the bank. The refresh address is generated by an internal refresh controller, effectively making each address bit a “Don’t Care” during the AREF command. See the AUTO REFRESH (AREF) section for more details.	

- Notes: 1. When the chip is deselected, internal NOP commands are generated and no commands are accepted.
2. $n = 20$.

Table 20: Command Table

Operation	Code	CS#	WE#	REF#	A0–An ²	BA0–BA2	Notes
DEVICE DESELECT/NO OPERATION	DSEL/NOP	H	X	X	X	X	
MRS	MRS	L	L	L	OPCODE	X	3
READ	READ	L	H	H	A	BA	4
WRITE	WRITE	L	L	H	A	BA	4
AUTO REFRESH	AREF	L	H	L	X	BA	

- Notes: 1. Applies to entire table: X = “Don’t Care;” H = logic HIGH; L = logic LOW; A = valid address; BA = valid bank address; $n = 20$.
2. Only A0–A17 are used for the MRS command.
3. Address width varies with burst length; see the Address Widths at Different Burst Lengths table.

MODE REGISTER SET (MRS) Command

The mode register set stores the data for controlling the operating modes of the memory. It programs the configuration, burst length, test mode, and I/O options. During an MRS command, the address inputs A0–A17 are sampled and stored in the mode register. After issuing a valid MRS command, t_{MRSC} must be met before any command can be issued to the device. This statement does not apply to the consecutive MRS commands needed for internal logic reset during the initialization routine. The MRS command can only be issued when all banks are idle and no other operation is in progress.

Note: The data written by the prior burst length is not guaranteed to be accurate when the burst length of the device is changed.

Figure 13: Mode Register Set

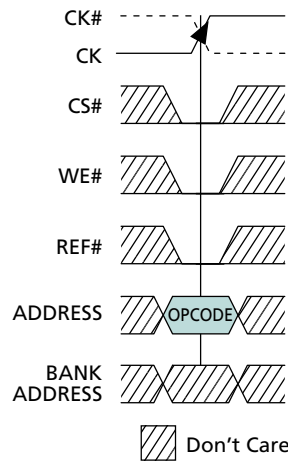
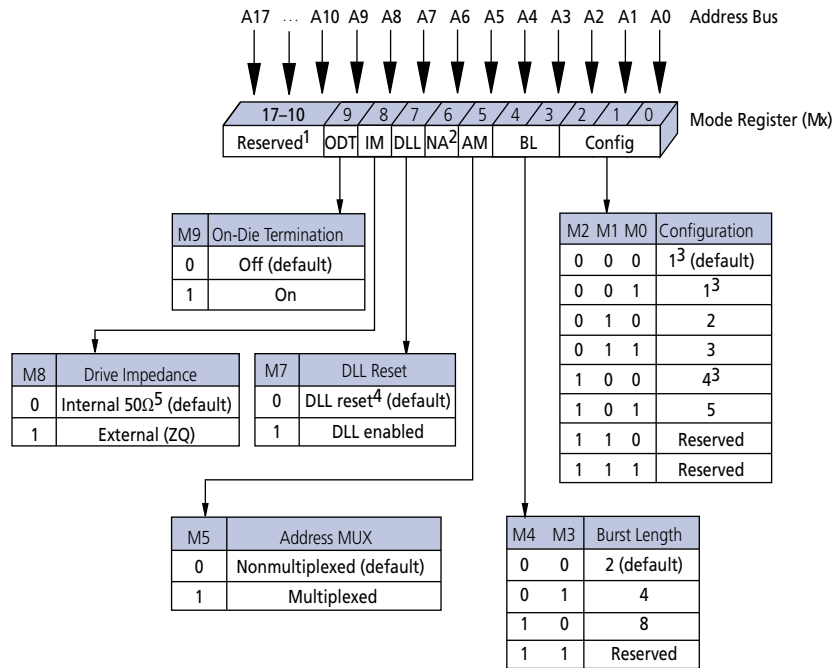

Figure 14: Mode Register Definition in Nonmultiplexed Address Mode



- Notes:
1. A10–A17 must be set to zero; A18–An = “Don’t Care.”
 2. A6 not used in MRS.
 3. BL = 8 is not available.
 4. DLL RESET turns the DLL off.
 5. $\pm 30\%$ temperature variation.

Configuration Tables

The table here shows the different configurations that can be programmed into the mode register. The WRITE latency is equal to the READ latency plus one in each configuration in order to maximize data bus utilization. Bits M0, M1, and M2 are used to select the configuration during the MRS command.

Table 21: Cycle Time and READ/WRITE Latency Configuration Table

Note 1 applies to entire table

Parameter	Configuration					Units
	1 ²	2	3	4 ^{2, 3}	5	
t _{RC}	4	6	8	3	5	t _{CK}
t _{RL}	4	6	8	3	5	t _{CK}
t _{WL}	5	7	9	4	6	t _{CK}
Valid frequency range	266–175	400–175	533–175	200–175	333–175	MHz

- Notes:
1. t_{RC} < 20ns in any configuration only available with -25E and -18 speed grades.
 2. BL = 8 is not available.
 3. The minimum t_{RC} is typically 3 cycles, except in the case of a WRITE followed by a READ to the same bank. In this instance the minimum t_{RC} is 4 cycles.

Burst Length (BL)

Burst length is defined by mode register bits M3 and M4. Device read and write accesses are burst-oriented, with burst length programmable to 2, 4, or 8. Shown here are the different burst lengths with respect to a READ command. Changes to burst length affect the width of the address bus (see the Address Widths at Different Burst Lengths table).

Note: When the device burst length is changed, data written by a prior burst length is not guaranteed as accurate.

Figure 15: Read Burst Lengths

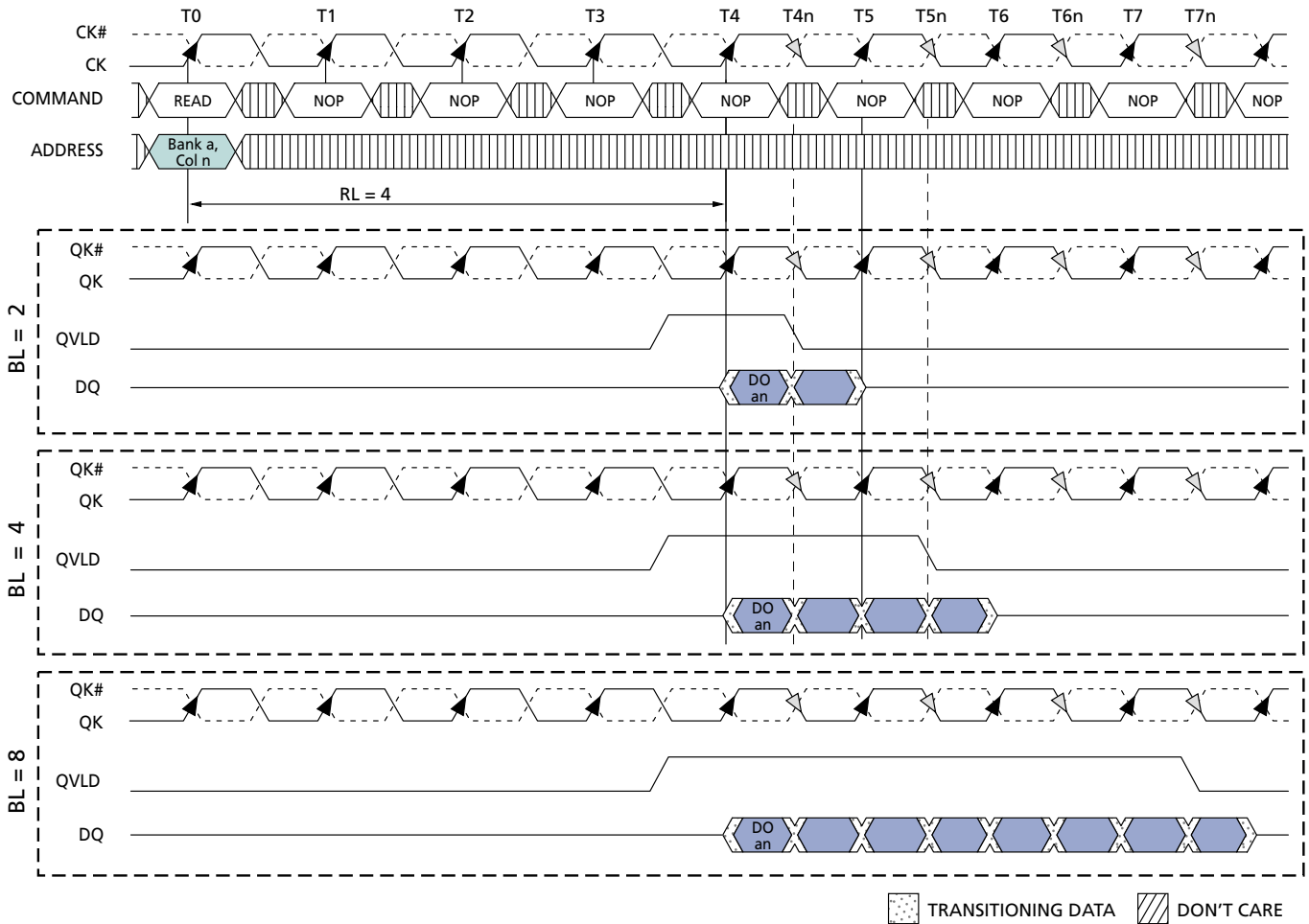

- Notes: 1. DO *an* = data-out from bank *a* and address *an*.
 2. Subsequent elements of data-out appear after DO *n*.
 3. Shown with nominal ^tCKQK.

Table 22: Address Widths at Different Burst Lengths

Burst Length	x9	x18	x36
2	A0–A20	A0–A19	A0–A18
4	A0–A19	A0–A18	A0–A17
8	A0–A18	A0–A17	A0–A16 ¹

Note: 1. Only available on Rev B die.

Address Multiplexing

The multiplexed address option is available by setting mode register bit M5 to 1. Once this bit is set, the READ, WRITE, and MRS commands follow the format described in the Command Description in Multiplexed Address Mode figure. Further information on operation with multiplexed addresses can be seen in the Multiplexed Address Mode section.

Although the device has the ability to operate with an SRAM interface by accepting the entire address in one clock, an option in the mode register can be set so that it functions with multiplexed addresses, similar to a traditional DRAM.

In multiplexed address mode, the address can be provided to the device in two parts that are latched into the memory with two consecutive rising clock edges. This provides the advantage of only needing a maximum of 11 address balls to control the device, reducing the number of signals on the controller side. The data bus efficiency in continuous burst mode is only affected when using the BL = 2 setting because the device requires two clocks to read and write the data.

The bank addresses are delivered to the device at the same time as the WRITE and READ command and the first address part, Ax. The Address Mapping in Multiplexed Address Mode table shows the addresses needed for both the first and second rising clock edges (Ax and Ay, respectively).

The AREF command does not require an address on the second rising clock edge, as only the bank address is needed during this command. Because of this, AREF commands may be issued on consecutive clocks.

DLL RESET

DLL reset is selected with bit M7 of the mode register. The default setting for this option is LOW, whereby the DLL is disabled.

Once M7 is set HIGH, 1024 cycles (5 μ s at 200 MHz) are needed before a READ command can be issued. This time enables the internal clock to be synchronized with the external clock.

Failing to wait for synchronization to occur may result in a violation of the t_{CKQK} parameter.

A reset of the DLL is necessary if t_{CK} or V_{DD} is changed after the DLL has already been enabled. To reset the DLL, an MRS command must be issued where M7 is set LOW. After waiting t_{MRSC} , a subsequent MRS command should be issued whereby M7 goes HIGH. 1024 clock cycles are then needed before a READ command is issued.

Drive Impedance Matching

The device is equipped with programmable impedance output buffers. This option is selected by setting bit M8 HIGH during the MRS command. The purpose of the programmable impedance output buffers is to enable the user to match the driver impedance to the system. To adjust the impedance, an external precision resistor (RQ) is connected between the ZQ ball and V_{SS} . The value of the resistor must be five times the desired impedance. For example, a 300 Ω resistor is required for an output impedance of 60 Ω . The range of RQ is 125–300 Ω , which guarantees output impedance in the range of 25–60 Ω (within 15%).

Output impedance updates may be required because over time variations may occur in supply voltage and temperature. When the external drive impedance is enabled in the MRS, the device will periodically sample the value of RQ. An impedance update is transparent to the system and does not affect device operation. All data sheet timing and current specifications are met during an update.

When bit M8 is set LOW during the MRS command, the device provides an internal impedance at the output buffer of 50Ω (±30% with temperature variation). This impedance is also periodically sampled and adjusted to compensate for variation in supply voltage and temperature.

On-Die Termination (ODT)

ODT is enabled by setting M9 to a value of 1 during an MRS command. With ODT on, the DQ and DM are terminated to V_{TT} with a resistance R_{TT} . The command, address, QVLD, and clock signals are not terminated.

The ODT function is dynamically switched off when DQ begins to drive after a READ command is issued. Similarly, ODT is designed to switch on at DQ after the device has issued the last piece of data. The DM pin will always be terminated.

Table 23: On-Die Termination DC Parameters

Description	Symbol	Min	Max	Units	Notes
Termination voltage	V_{TT}	$0.95 \times V_{REF}$	$1.05 \times V_{REF}$	V	1, 2
On-die termination	R_{TT}	125	185	Ω	3

- Notes:
1. All voltages referenced to V_{SS} (GND).
 2. V_{TT} is expected to be set equal to V_{REF} and must track variations in the DC level of V_{REF} .
 3. The R_{TT} value is measured at 95°C T_C .

Figure 16: On-Die Termination-Equivalent Circuit

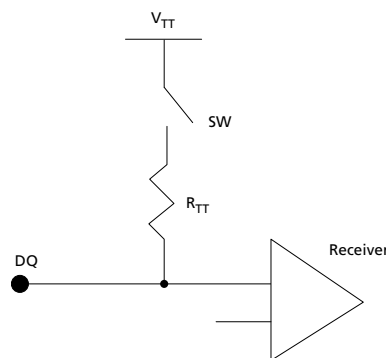

READ Command

Read accesses are initiated with a READ command, as shown in the figure below. Addresses are provided with the READ command.

During READ bursts, the memory device drives the read data so it is edge-aligned with the QKx signals. After a programmable READ latency, data is available at the outputs. One half clock cycle prior to valid data on the read bus, the data valid signal, QVLD, transitions from LOW to HIGH. QVLD is also edge-aligned with the QKx signals.

The skew between QK and the crossing point of CK is specified as t_{CKQK} . t_{QKQ0} is the skew between QK0 and the last valid data edge generated at the DQ signals associated with QK0 (t_{QKQ0} is referenced to DQ0–DQ17 for the x36 configuration and DQ0–DQ8 for the x18 configuration). t_{QKQ1} is the skew between QK1 and the last valid data edge generated at the DQ signals associated with QK1 (t_{QKQ1} is referenced to DQ18–DQ35 for the x36 and DQ9–DQ17 for the x18 configuration). t_{QKQx} is derived at each QKx clock edge and is not cumulative over time. t_{QKQ} is defined as the skew between either QK differential pair and any output data edge.

After completion of a burst, assuming no other commands have been initiated, output data (DQ) will go High-Z. The QVLD signal transitions LOW on the last bit of the READ burst. Note that if CK/CK# violates the $V_{id(DC)}$ specification while a READ burst is occurring, QVLD will remain HIGH until a dummy READ command is issued. The QK clocks are free-running and will continue to cycle after the READ burst is complete. Back-to-back READ commands are possible, producing a continuous flow of output data.

The data valid window is derived from each QK transition and is defined as:

$t_{QHP} - (t_{QKQ} [MAX] + |t_{QKQ} [MIN]|)$. See the Read Data Valid Window for x9 Device figure, the Read Data Valid Window for x18 Device figure, and the Read Data Valid Window for x36 Device figure for illustration.

Any READ burst may be followed by a subsequent WRITE command. The READ-to-WRITE figure illustrates the timing requirements for a READ followed by a WRITE. Some systems having long line lengths or severe skews may need additional idle cycles inserted between READ and WRITE commands to prevent data bus contention.

Figure 17: READ Command

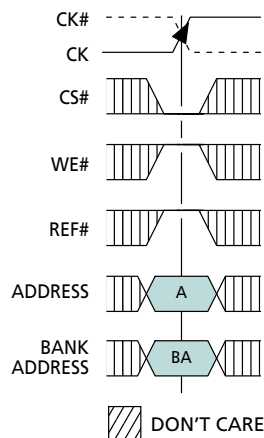

WRITE Command

Write accesses are initiated with a WRITE command, as shown in the figure below. The address needs to be provided during the WRITE command.

During WRITE commands, data will be registered at both edges of DK according to the programmed burst length (BL). The device operates with a WRITE latency (WL) that is one cycle longer than the programmed READ latency (RL + 1), with the first valid data registered at the first rising DK edge WL cycles after the WRITE command.

Any WRITE burst may be followed by a subsequent READ command (assuming ^tRC is met). To avoid external data bus contention, at least one NOP command is needed between the WRITE and READ commands. The WRITE-to-READ figure and the WRITE-to-READ (Separated by Two NOPs) figure illustrate the timing requirements for a WRITE followed by a READ where one and two intermediary NOPs are required, respectively.

Setup and hold times for incoming DQ relative to the DK edges are specified as ^tDS and ^tDH. The input data is masked if the corresponding DM signal is HIGH. The setup and hold times for the DM signal are also ^tDS and ^tDH.

Figure 18: WRITE Command

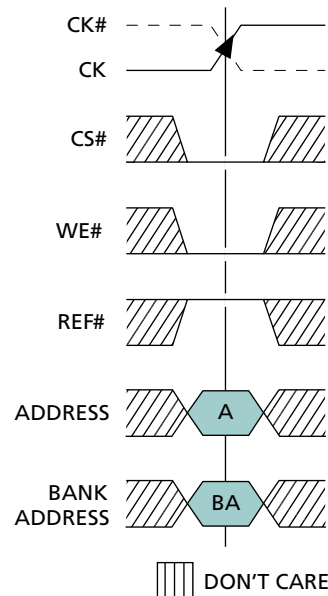

AUTO REFRESH (AREF) Command

AREF is used to perform a REFRESH cycle on one row in a specific bank. Because the row addresses are generated by an internal refresh counter for each bank, the external address balls are “Don’t Care.” The bank addresses must be provided during the AREF command. The bank address is needed during the AREF command so refreshing of the part can effectively be hidden behind commands to other banks. The delay between the AREF command and a subsequent command to the same bank must be at least t_{RC} .

Within a period of 32ms (t_{REF}), the entire device must be refreshed. The 288Mb device requires 64K cycles at an average periodic interval of 0.49 μ s MAX (actual periodic refresh interval is 32ms/8K rows/8 banks = 0.488 μ s). To improve efficiency, eight AREF commands (one for each bank) can be posted to the device at periodic intervals of 3.9 μ s (32ms/8K rows = 3.90 μ s).

Figure 19: AUTO REFRESH Command

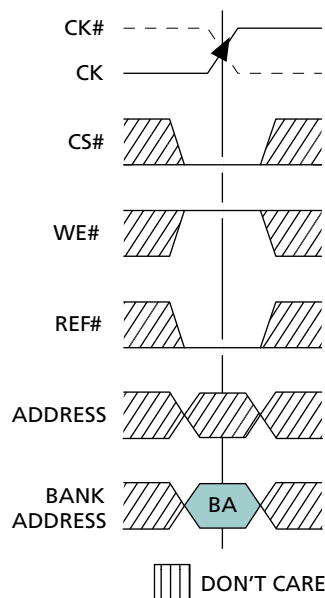

INITIALIZATION Operation

The device must be powered up and initialized in a predefined manner. Operational procedures other than those specified may result in undefined operations or permanent damage to the device.

The following sequence is used for power-up:

1. Apply power (V_{EXT} , V_{DD} , V_{DDQ} , V_{REF} , V_{TT}) and start clock as soon as the supply voltages are stable. Apply V_{DD} and V_{EXT} before or at the same time as V_{DDQ} .¹ Apply V_{DDQ} before or at the same time as V_{REF} and V_{TT} . Although there is no timing relation between V_{EXT} and V_{DD} , the chip starts the power-up sequence only after both voltages approach their nominal levels. $CK/CK\#$ must meet $V_{ID(DC)}$ prior to being applied.² Apply NOP conditions to command pins. Ensuring $CK/CK\#$ meet $V_{ID(DC)}$ while applying NOP conditions to the command pins guarantees that the device will not receive unwanted commands during initialization.
2. Maintain stable conditions for 200 μ s (MIN).
3. Issue at least three consecutive MRS commands: two dummies or more plus one valid MRS. The purpose of these consecutive MRS commands is to internally reset the logic of the device. Note that tMRSC does not need to be met between these consecutive commands. It is recommended that all address pins are held LOW during the dummy MRS commands.
4. tMRSC after the valid MRS, an AUTO REFRESH command to all 8 banks (along with 1024 NOP commands) must be issued prior to normal operation. The sequence of the eight AUTO REFRESH commands (with respect to the 1024 NOP commands) does not matter. As is required for any operation, tRC must be met between an AUTO REFRESH command and a subsequent VALID command to the same bank. Note that previous versions of the data sheet required each of these AUTO REFRESH commands be separated by 2048 NOP commands. This properly initializes the device but is no longer required.

Notes:

1. It is possible to apply V_{DDQ} before V_{DD} ; when doing so, however, DQ, DM, and all other pins with an output driver will go HIGH instead of tri-stating. These pins will remain HIGH until V_{DD} is at the same level as V_{DDQ} . Care should be taken to avoid bus conflicts during this period.
2. If $V_{ID(DC)}$ on $CK/CK\#$ cannot be met prior to being applied to the device, placing a large external resistor from $CS\#$ to V_{DD} is a viable option for ensuring the command bus does not receive unwanted commands during this unspecified state.

Figure 20: Power-Up/Initialization Sequence

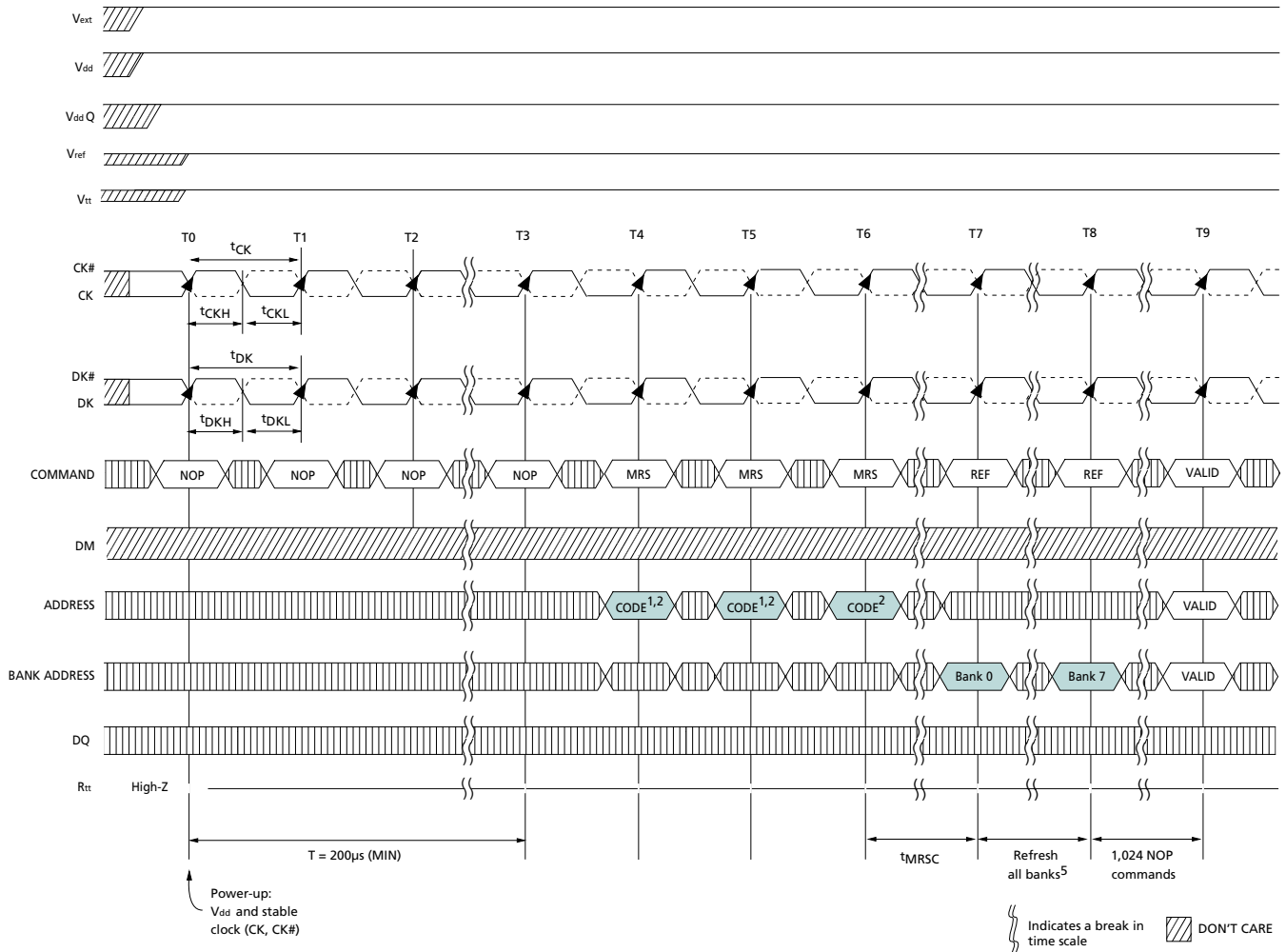

- Notes:
1. Recommend all address pins held LOW during dummy MRS commands.
 2. A10–A17 must be LOW.
 3. DLL must be reset if t_{CK} or V_{DD} are changed.
 4. CK and CK# must be separated at all times to prevent bogus commands from being issued.
 5. The sequence of the eight AUTO REFRESH commands (with respect to the 1024 NOP commands) does not matter. As is required for any operation, t_{RC} must be met between an AUTO REFRESH command and a subsequent valid command to the same bank.

Figure 21: Power-Up/Initialization Flow Chart

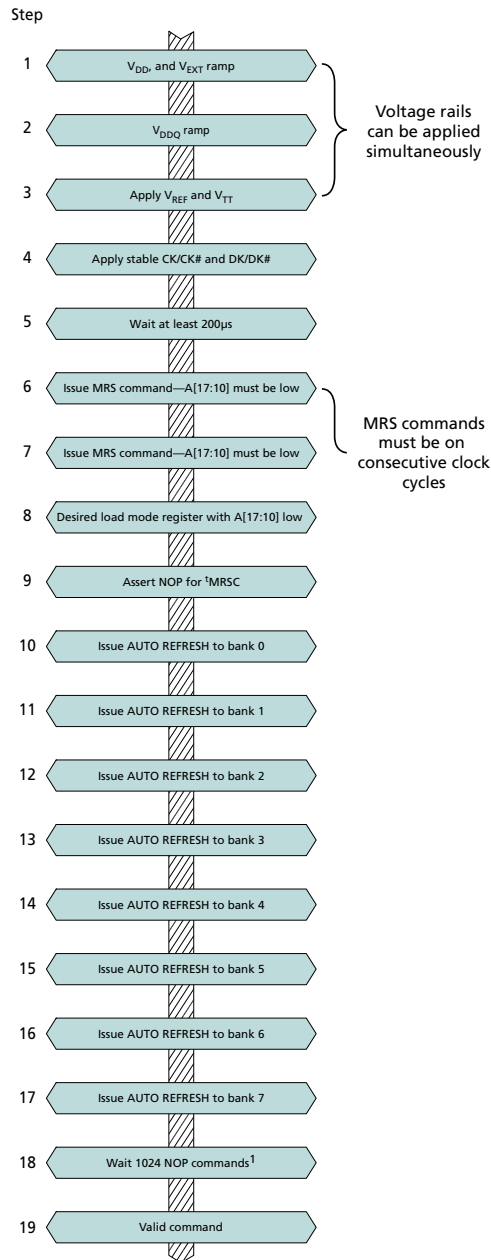

Note: 1. The sequence of the eight AUTO REFRESH commands (with respect to the 1024 NOP commands) does not matter. As is required for any operation, tRC must be met between an AUTO REFRESH command and a subsequent valid command to the same bank.

READ Operations

Figure 22: Basic READ Burst Timing

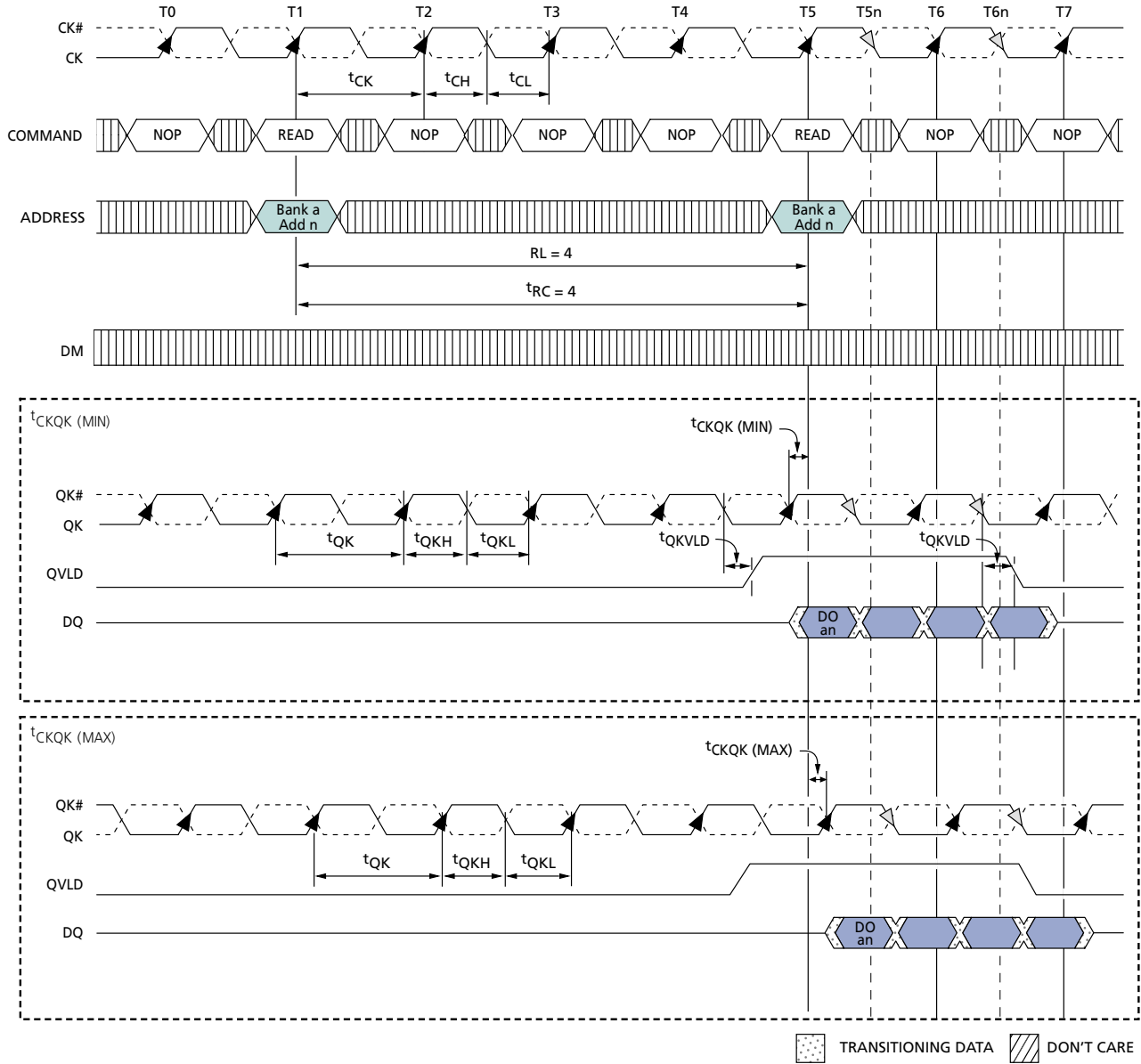

- Notes:
1. DO a_n = data-out from bank a and address a_n .
 2. Three subsequent elements of the burst are applied following DO a_n .
 3. BL = 4.
 4. Nominal conditions are assumed for specifications not defined.

Figure 23: Consecutive READ Bursts (BL = 2)

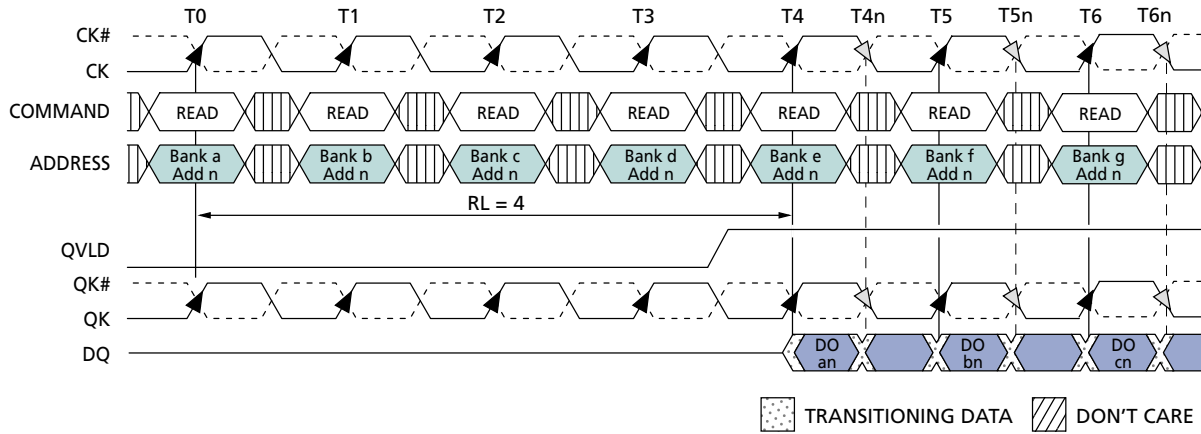

- Notes:
1. DO *an* (or *bn* or *cn*) = data-out from bank *a* (or bank *b* or bank *c*) and address *n*.
 2. One subsequent element of the burst from each bank appears after each DO *x*.
 3. Nominal conditions are assumed for specifications not defined.
 4. Example applies only when READ commands are issued to same device.
 5. Bank address can be to any bank, but the subsequent READ can only be to the same bank if t_{RC} has been met.
 6. Data from the READ commands to bank *d* through bank *g* will appear on subsequent clock cycles that are not shown.

Figure 24: Consecutive READ Bursts (BL = 4)

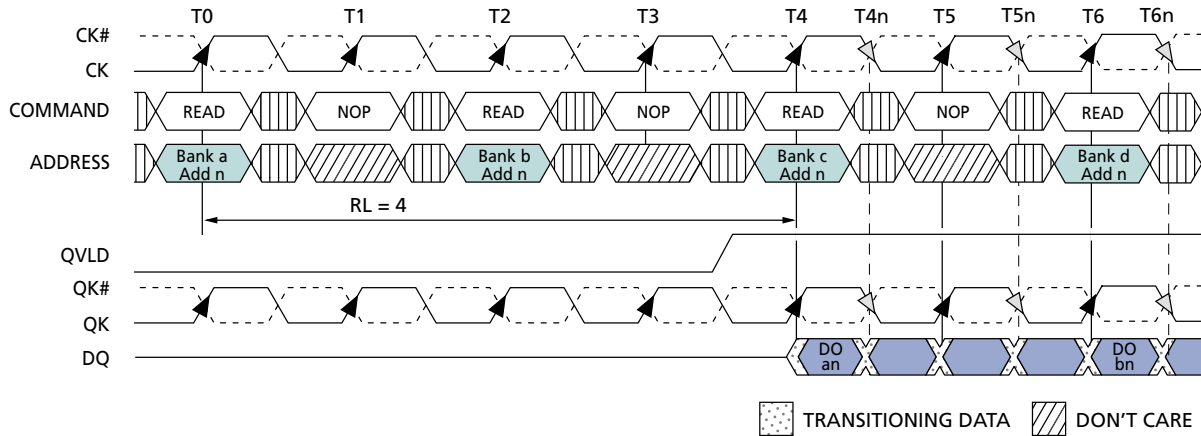

- Notes:
1. DO_{an} (or DO_{bn}) = data-out from bank a (or bank b) and address n .
 2. Three subsequent elements of the burst from each bank appears after each DO_x .
 3. Nominal conditions are assumed for specifications not defined.
 4. Example applies only when READ commands are issued to same device.
 5. Bank address can be to any bank, but the subsequent READ can only be to the same bank if t_{RC} has been met.
 6. Data from the READ commands to banks c and d will appear on subsequent clock cycles that are not shown.

Figure 25: READ-to-WRITE

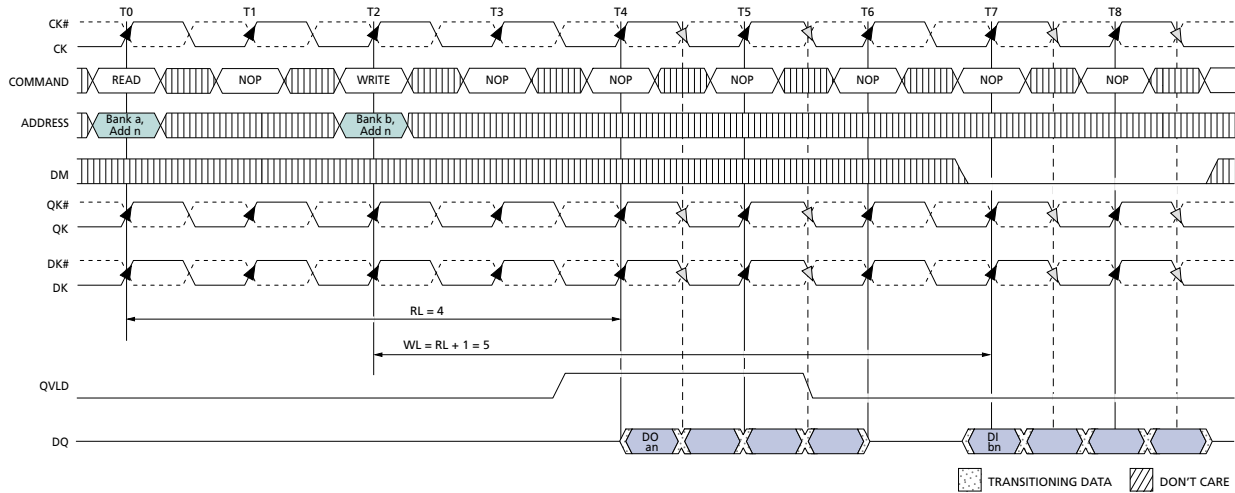

- Notes:
1. DO_{an} = data-out from bank a and address n .
 2. DI_{bn} = data-in for bank b and address n .
 3. Three subsequent elements of each burst follow DI_{bn} and each DO_{an} .
 4. $BL = 4$.
 5. Nominal conditions are assumed for specifications not defined.

Figure 26: Read Data Valid Window for x9 Device

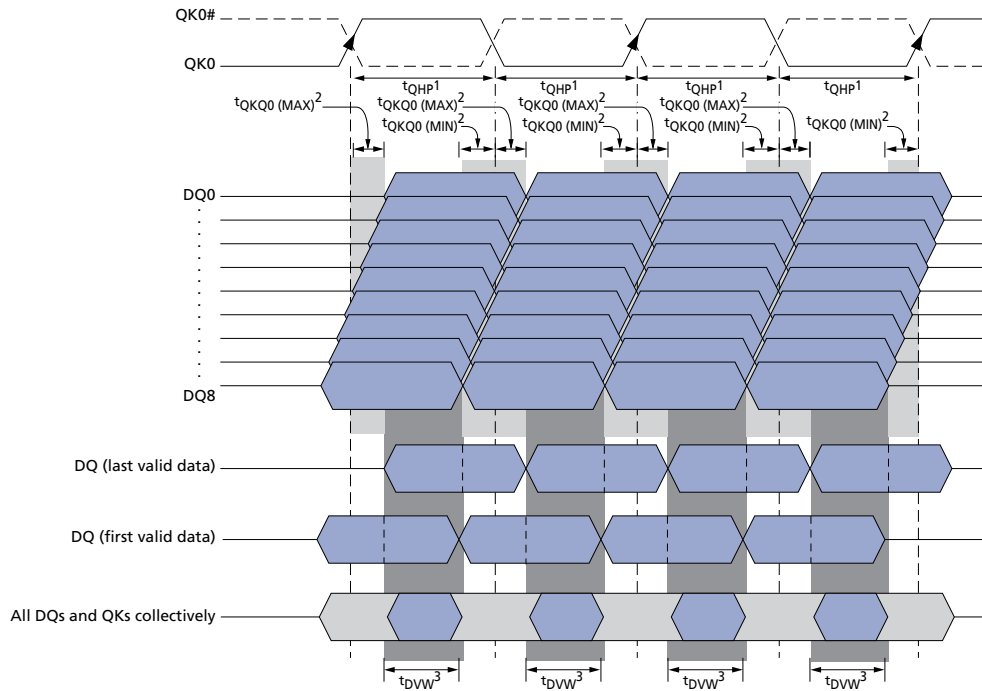

- Notes:
1. t_{QHP} is defined as the lesser of t_{QKH} or t_{QKL} .
 2. t_{QKQ0} is referenced to DQ0–DQ8.
 3. t_{DWW} can be expressed as $t_{QHP} - (t_{QKQx [MAX]} + |t_{QKQx [MIN]}|)$.

Figure 27: Read Data Valid Window for x18 Device

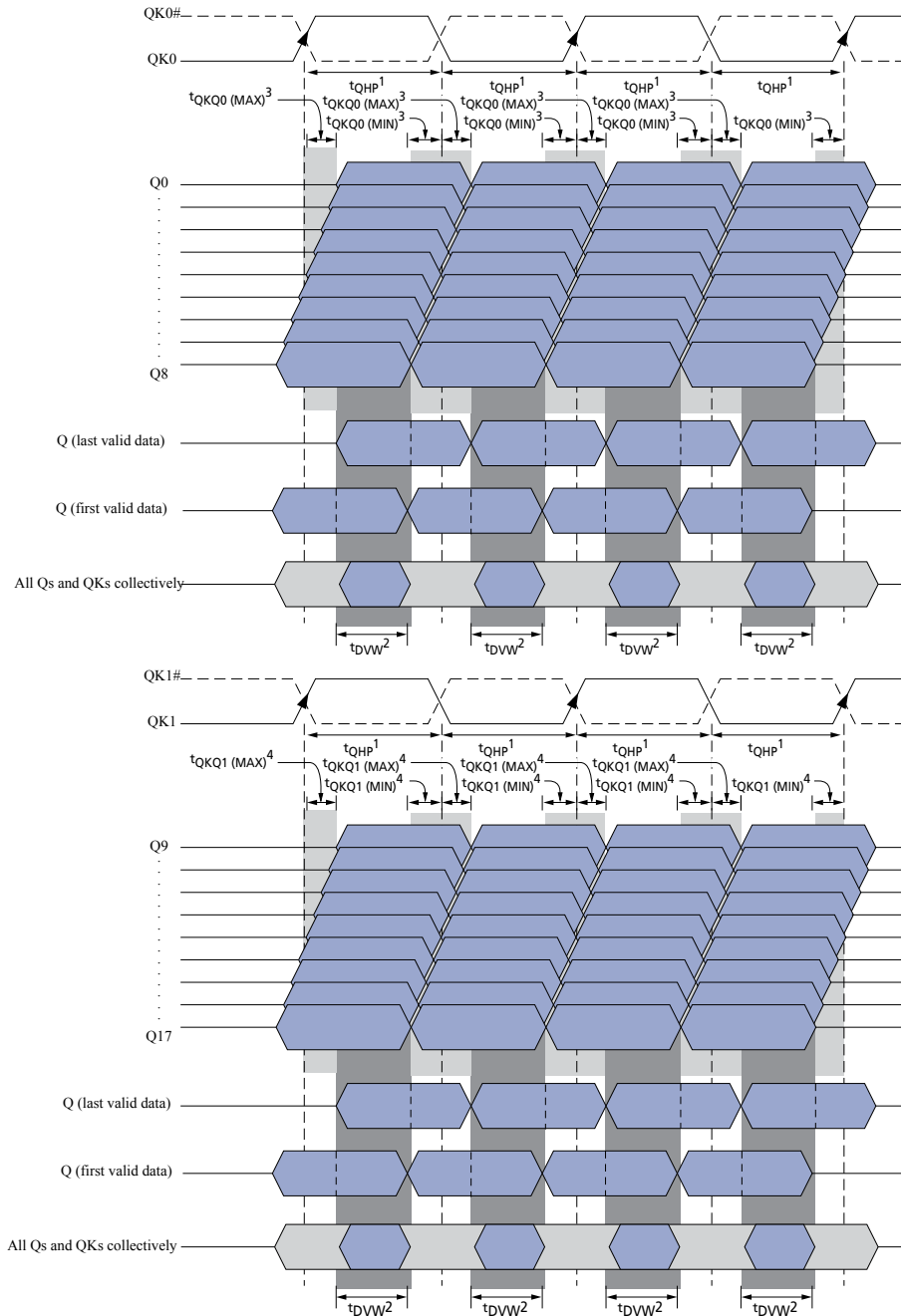

- Notes:
1. t_{QHP} is defined as the lesser of t_{QKH} or t_{QKL} .
 2. t_{QKQ0} is referenced to DQ0–DQ8.
 3. t_{DWW} can be expressed as $t_{QHP} - (t_{QKQx} [MAX] + |t_{QKQx} [MIN]|)$.
 4. t_{QKQ1} is referenced to DQ9–DQ17.
 5. t_{QKQ} takes into account the skew between any QKx and any DQ.

Figure 28: Read Data Valid Window for x36 Device

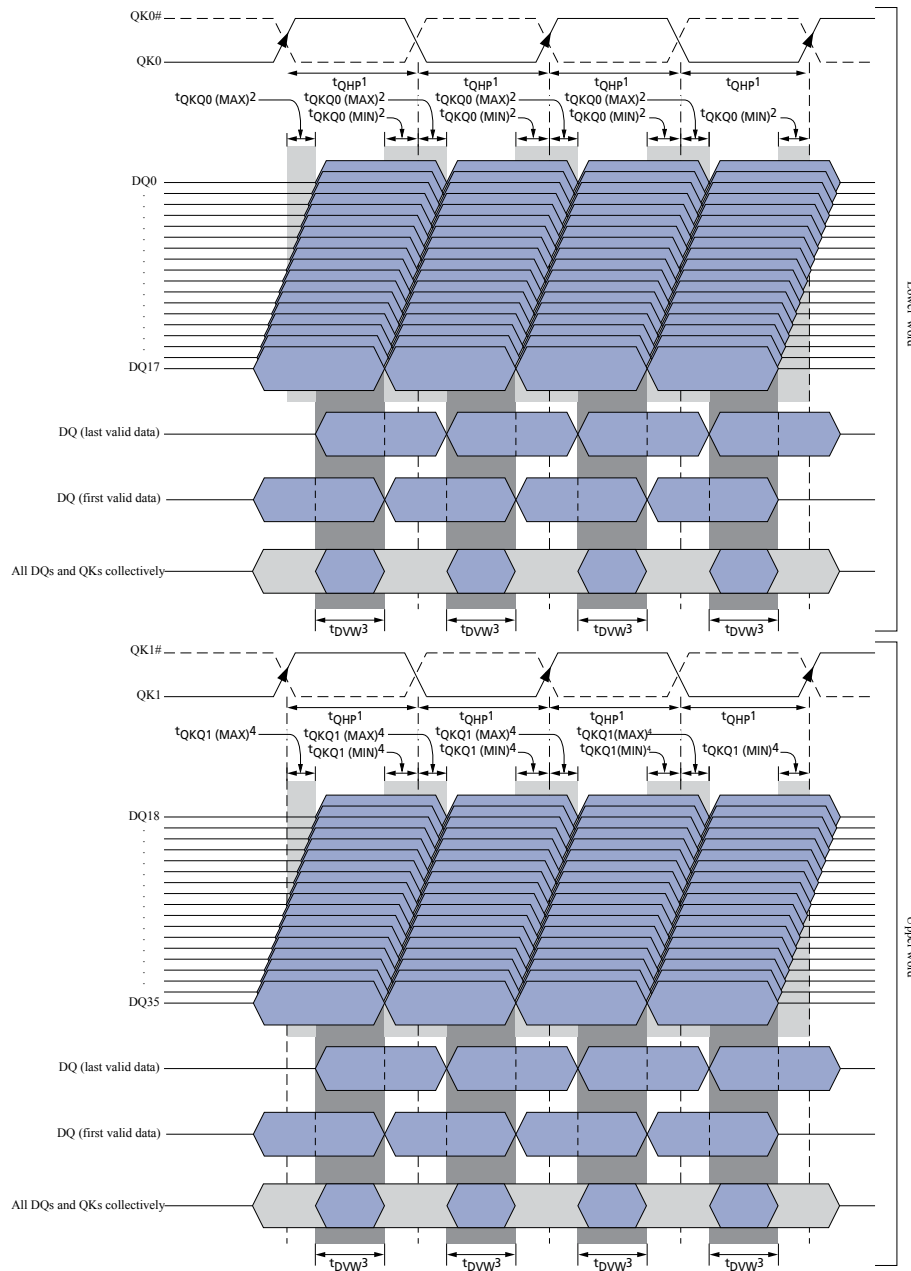

- Notes:
1. t_{QHP} is defined as the lesser of t_{QKH} or t_{QKL} .
 2. t_{QKQ0} is referenced to DQ0–DQ17.
 3. t_{DWW} can be expressed as $t_{QHP} - (t_{QKQx} [MAX] + |t_{QKQx} [MIN]|)$.
 4. t_{QKQ1} is referenced to DQ18–DQ35.
 5. t_{QKQ} takes into account the skew between any QKx and any DQ.

WRITE Operations

Figure 29: WRITE Burst

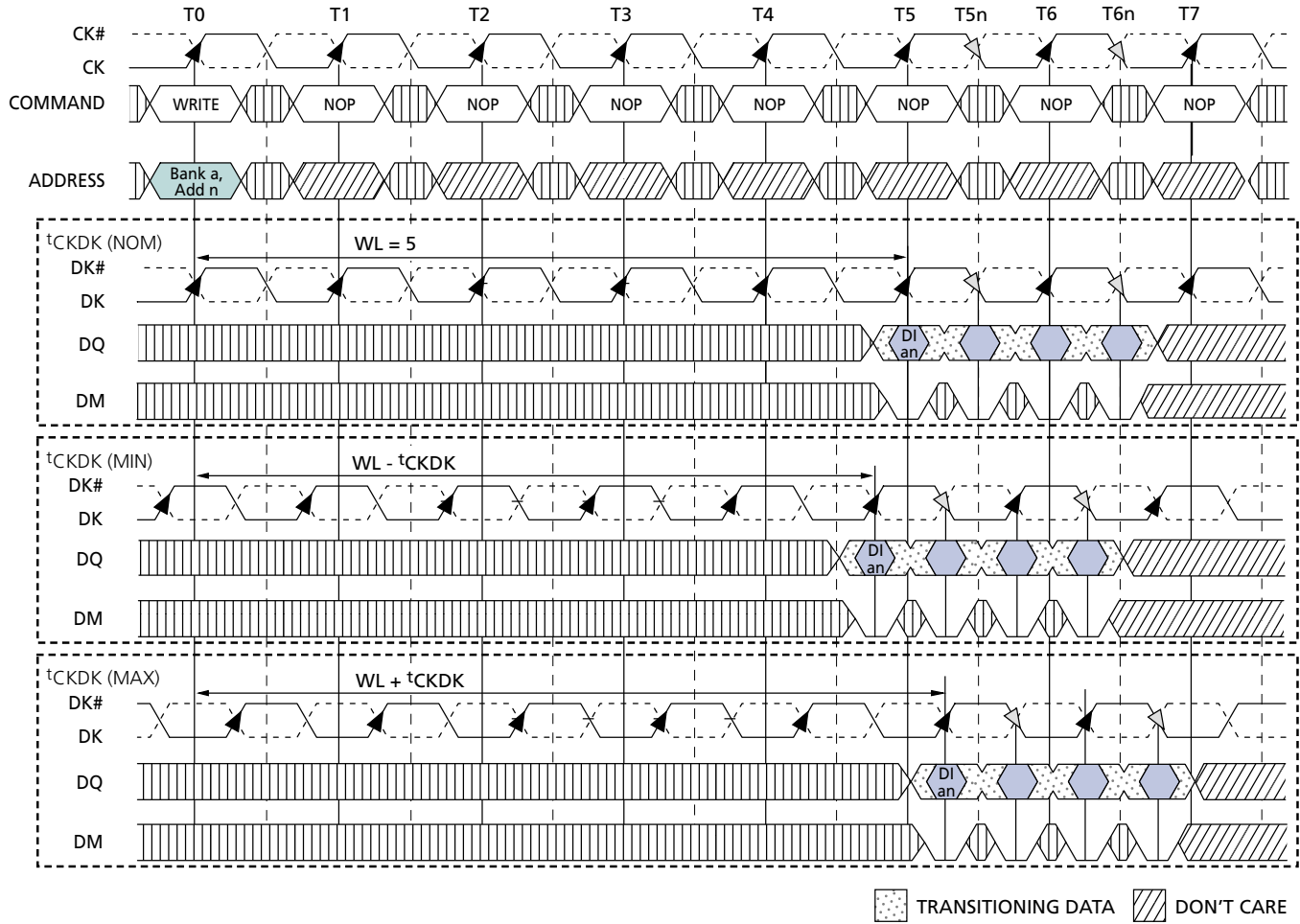

- Notes: 1. DI_{an} = data-in for address n; subsequent elements of burst are applied following DI_{an}.
2. BL = 4.

Figure 30: Consecutive WRITE-to-WRITE

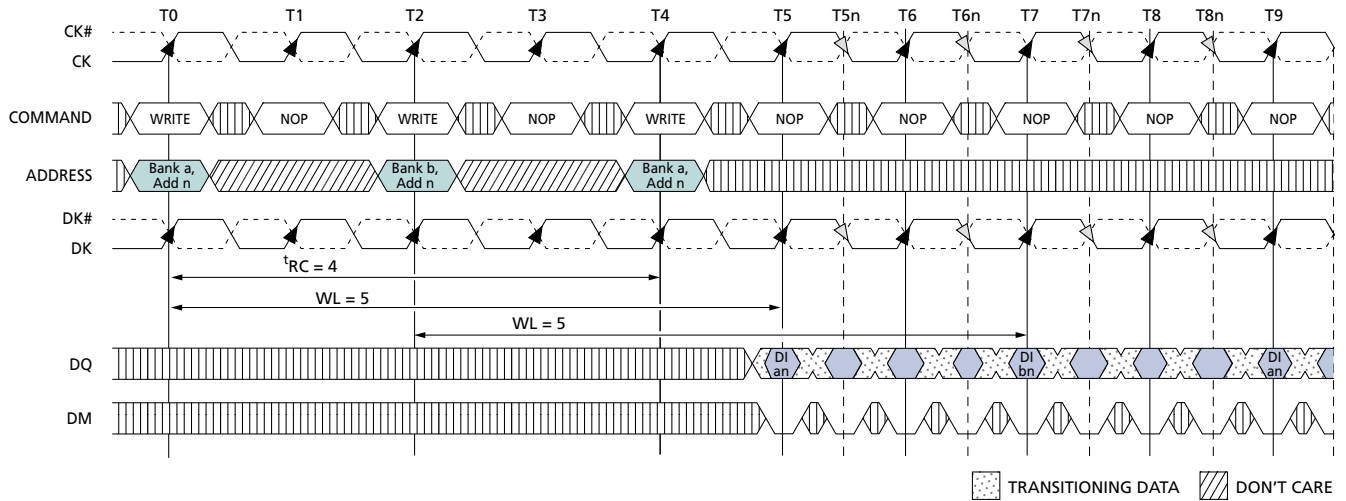

- Notes:
1. DI *an* (or *bn*) = data-in for bank a (or bank b) and address *n*.
 2. Three subsequent elements of the burst are applied following DI for each bank.
 3. BL = 4.
 4. Each WRITE command may be to any bank; if the second WRITE is to the same bank, t_{RC} must be met.
 5. Nominal conditions are assumed for specifications not defined.

Figure 31: WRITE-to-READ

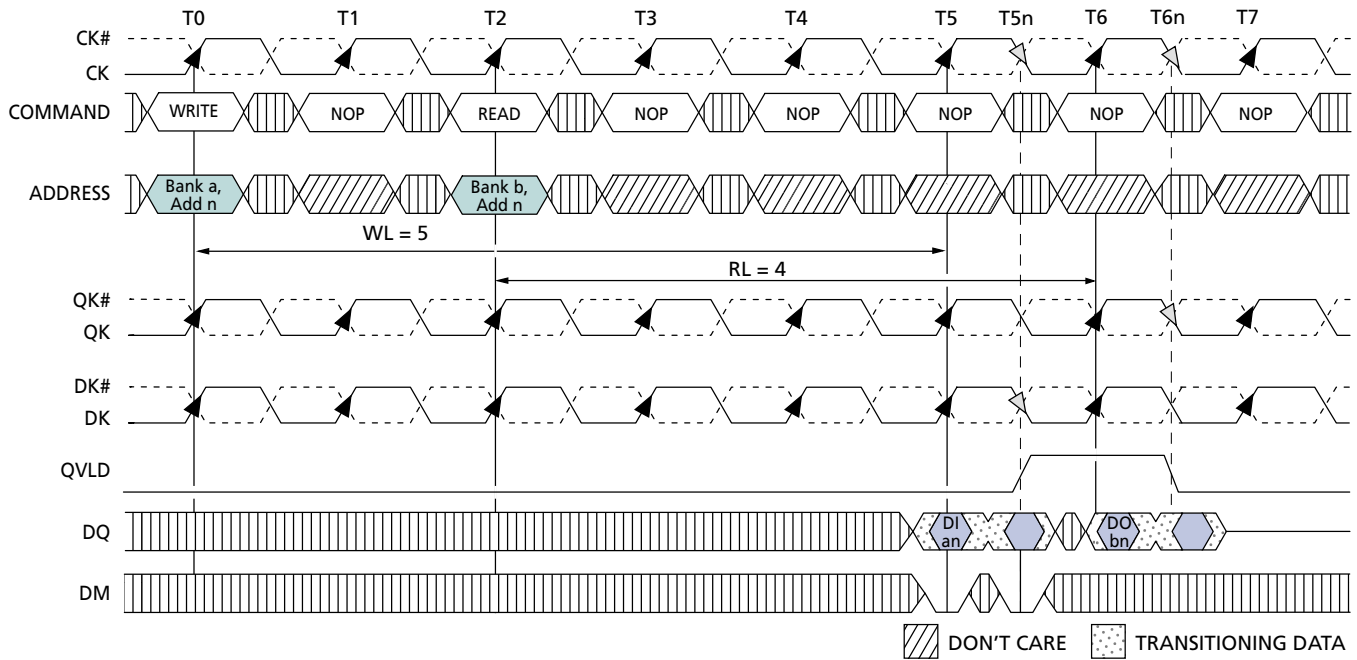

- Notes:
1. DI_{an} = data-in for bank a and address n .
 2. DO_{bn} = data-out from bank b and address n .
 3. Two subsequent elements of each burst follow DI_{an} and DO_{bn} .
 4. $BL = 2$.
 5. Nominal conditions are assumed for specifications not defined.

Figure 32: WRITE-to-READ – Separated by Two NOP Commands

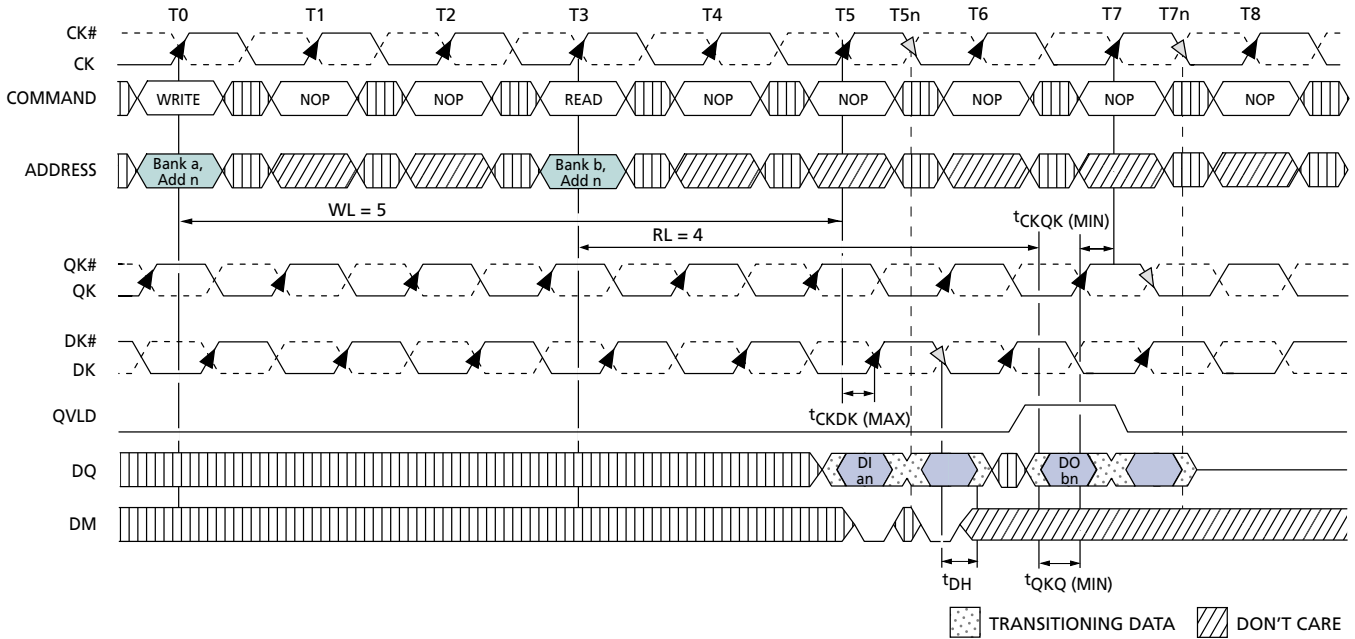

- Notes:
1. DI_{an} = data-in for bank a and address n .
 2. DO_{bn} = data-out from bank b and address n .
 3. One subsequent element of each burst follow DI_{an} and DO_{bn} .
 4. $BL = 2$.
 5. Only one NOP separating the WRITE and READ would have led to contention on the data bus because of the input and output data timing conditions being used.
 6. Nominal conditions are assumed for specifications not defined.

Figure 33: WRITE – DM Operation

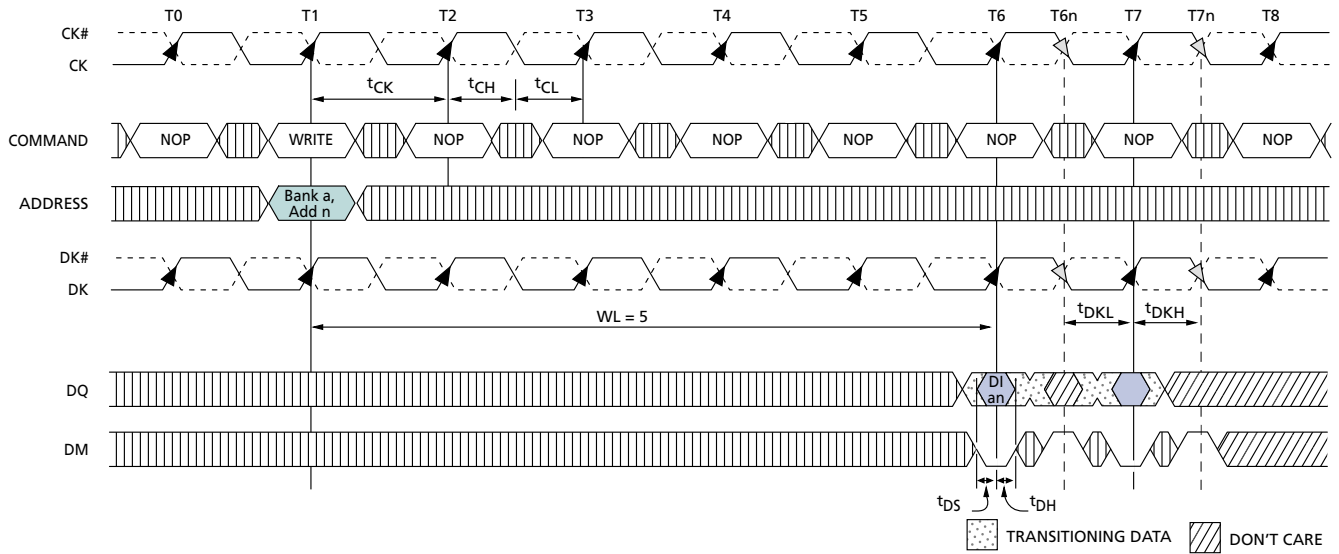

- Notes:
1. $DI\ n =$ data-in from address n .
 2. Subsequent elements of burst are provided on following clock edges.
 3. $BL = 4$.
 4. Nominal conditions are assumed for specifications not defined.

AUTO REFRESH Operation

Figure 34: AUTO REFRESH Cycle

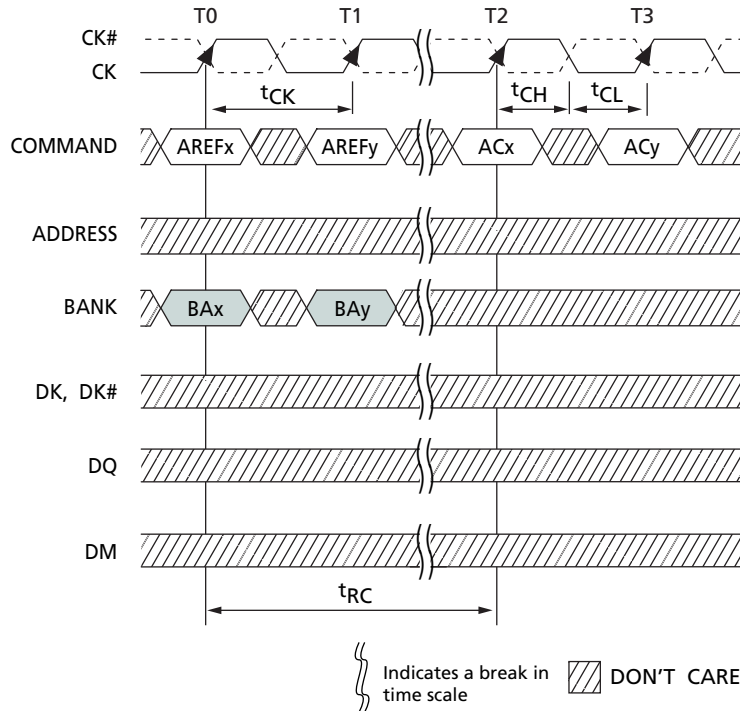

- Notes:
1. AREF_x = AUTO REFRESH command to bank *x*.
 2. AC_x = any command to bank *x*; AC_y = any command to bank *y*.
 3. BA_x = bank address to bank *x*; BA_y = bank address to bank *y*.

On-Die Termination

Figure 35: READ Burst with ODT

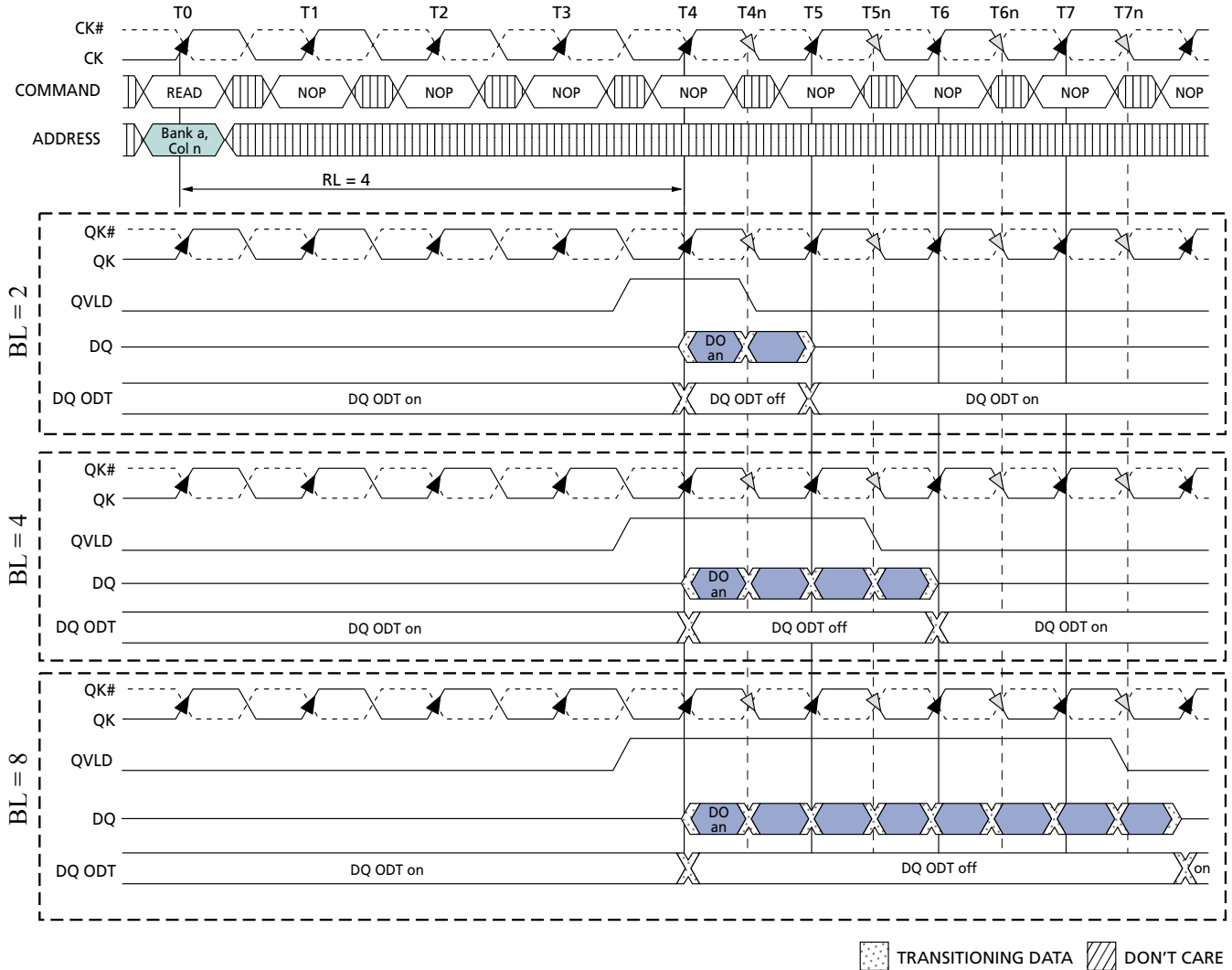

- Notes:
1. DO n = data out from bank a and address n .
 2. DO n is followed by the remaining bits of the burst.
 3. Nominal conditions are assumed for specifications not defined.

Figure 36: READ-NOP-READ with ODT

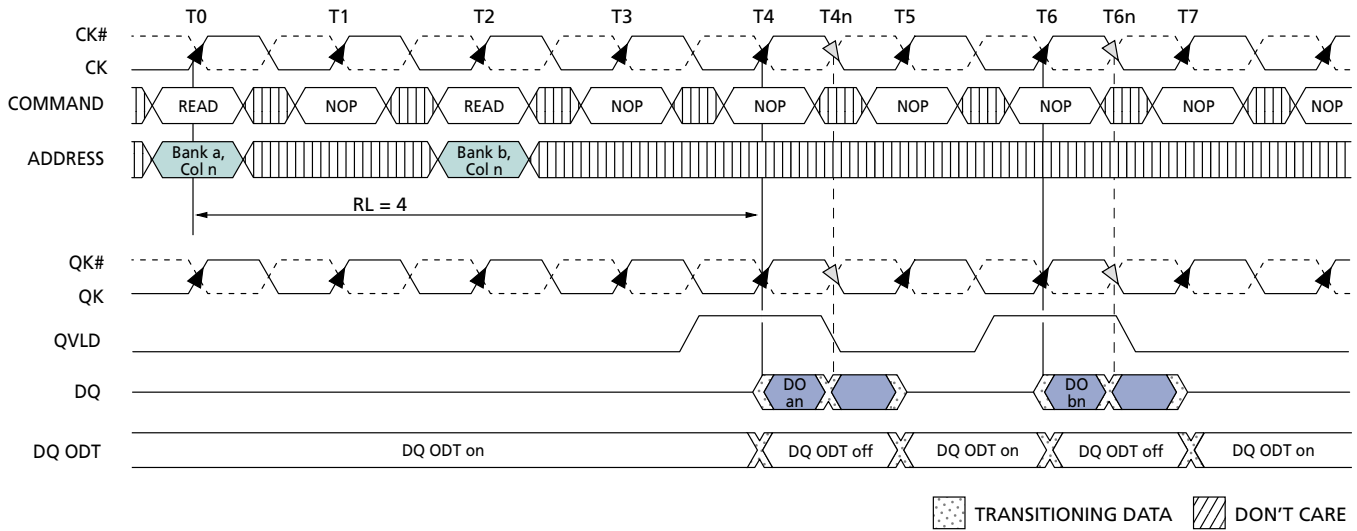

- Notes:
1. DO *an* (or *bn*) = data-out from bank *a* (or bank *b*) and address *n*.
 2. BL = 2.
 3. One subsequent element of the burst appears after DO *an* and DO *bn*.
 4. Nominal conditions are assumed for specifications not defined.

Figure 37: READ-to-WRITE with ODT

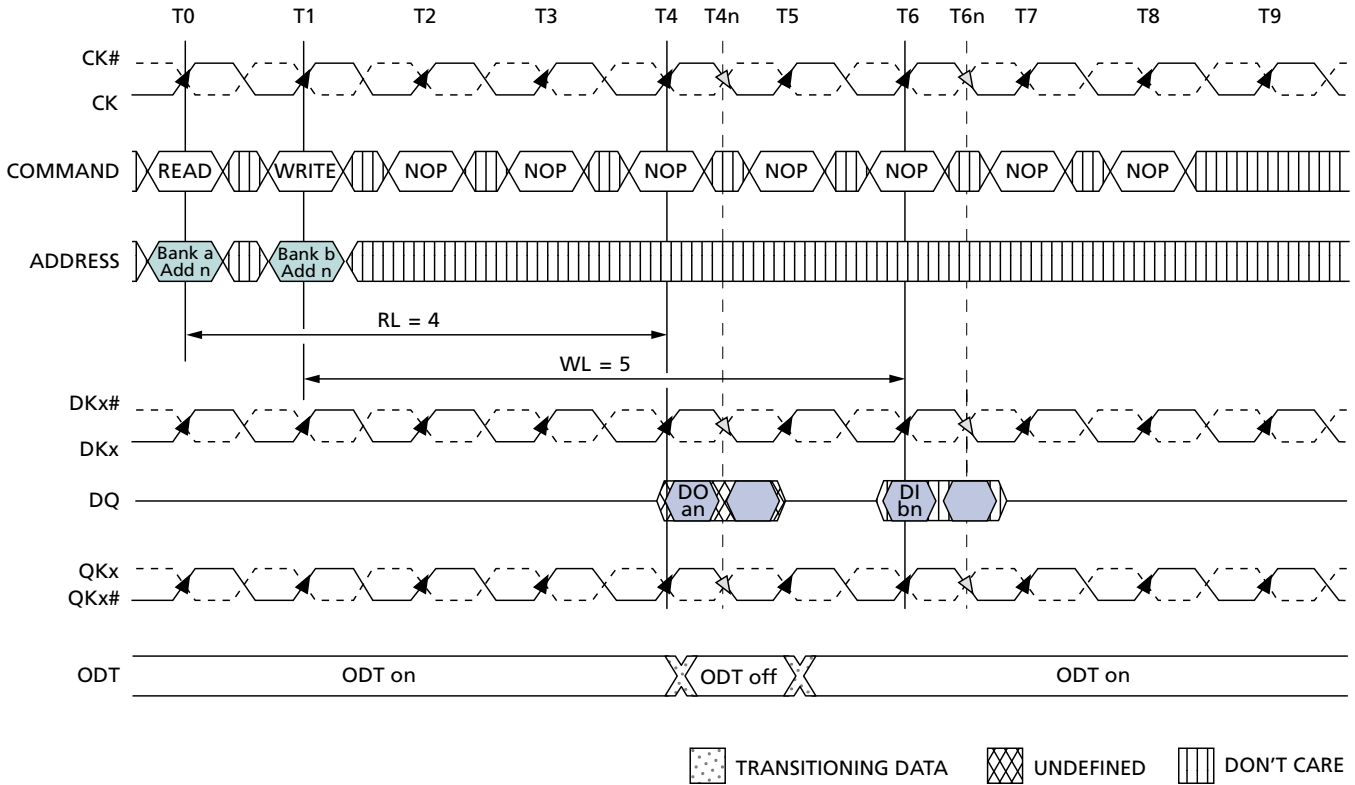

- Notes:
1. DO an = data-out from bank a and address n ; DI bn = data-in for bank b and address n .
 2. BL = 2.
 3. One subsequent element of each burst appears after each DO an and DI bn .
 4. Nominal conditions are assumed for specifications not defined.

Multiplexed Address Mode

Figure 38: Command Description in Multiplexed Address Mode

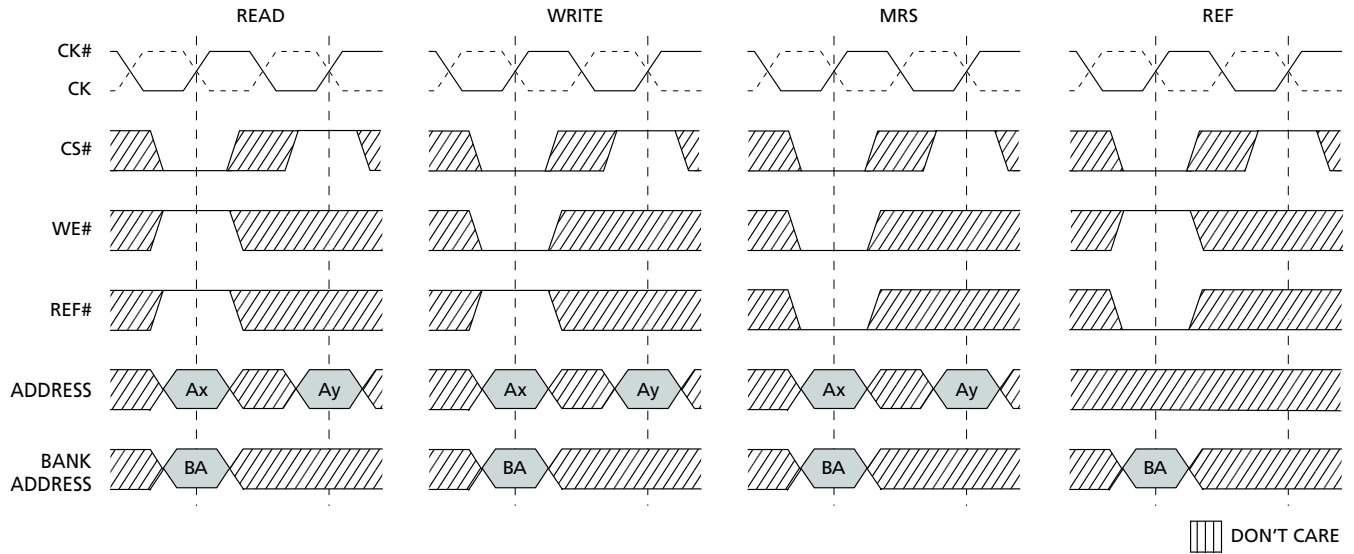

Note: 1. The minimum setup and hold times of the two address parts are defined t_{AS} and t_{AH} .

Figure 39: Power-Up/Initialization Sequence in Multiplexed Address Mode

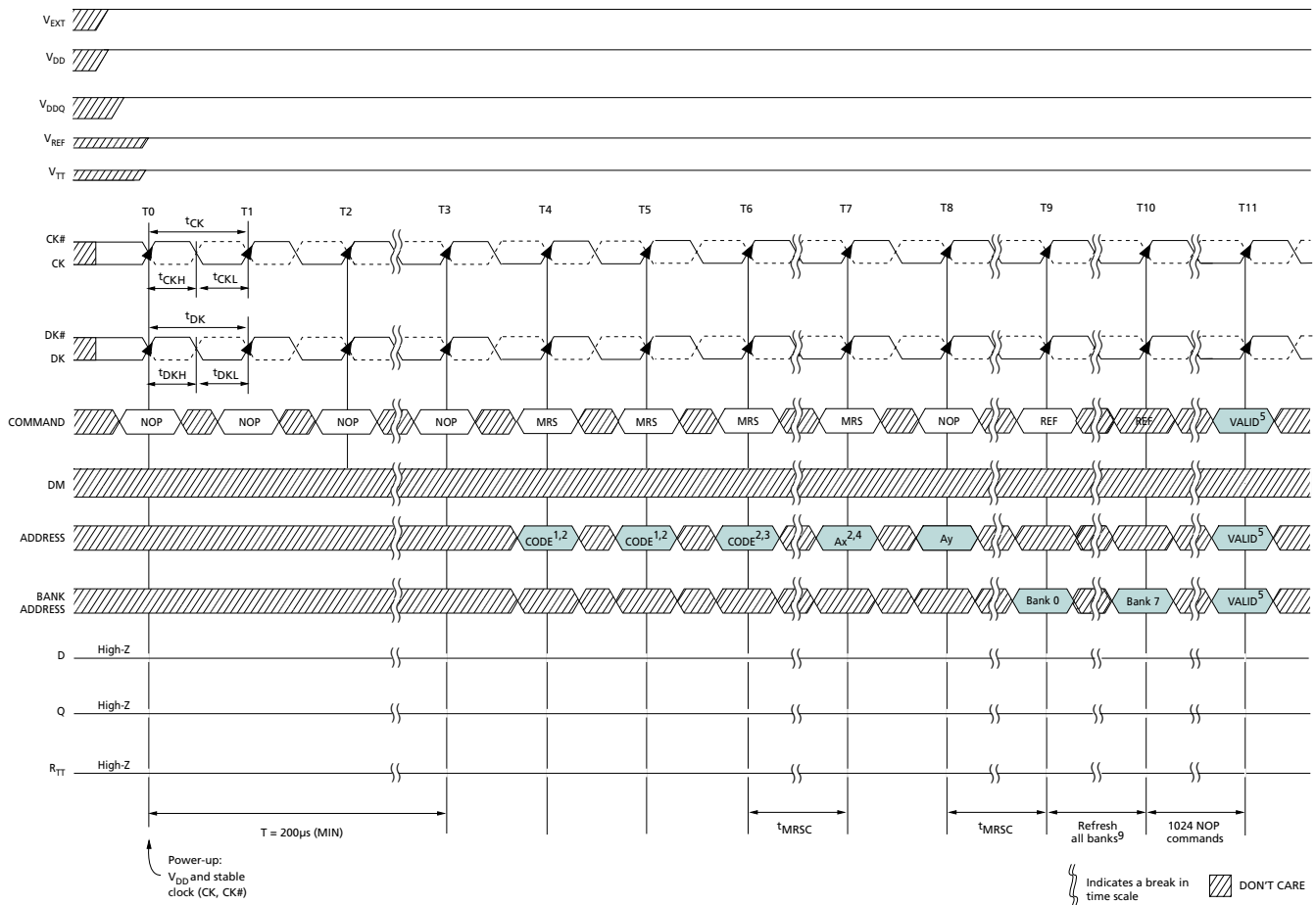

- Notes:
1. Recommended that all address pins held LOW during dummy MRS commands.
 2. A10–A18 must be LOW.
 3. Set address A5 HIGH. This enables the part to enter multiplexed address mode when in non-multiplexed mode operation. Multiplexed address mode can also be entered at some later time by issuing an MRS command with A5 HIGH. Once address bit A5 is set HIGH, t_{MRSC} must be satisfied before the two-cycle multiplexed mode MRS command is issued.
 4. Address A5 must be set HIGH. This and the following step set the desired mode register once the device is in multiplexed address mode.
 5. Any command or address.
 6. The above sequence must be followed in order to power up the device in the multiplexed address mode.
 7. DLL must be reset if t_{CK} or V_{DD} are changed.
 8. CK and CK# must separated at all times to prevent bogus commands from being issued.
 9. The sequence of the eight AUTO REFRESH commands (with respect to the 1024 NOP commands) does not matter. As is required for any operation, t_{RC} must be met between an AUTO REFRESH command and a subsequent VALID command to the same bank.

Figure 40: Mode Register Definition in Multiplexed Address Mode

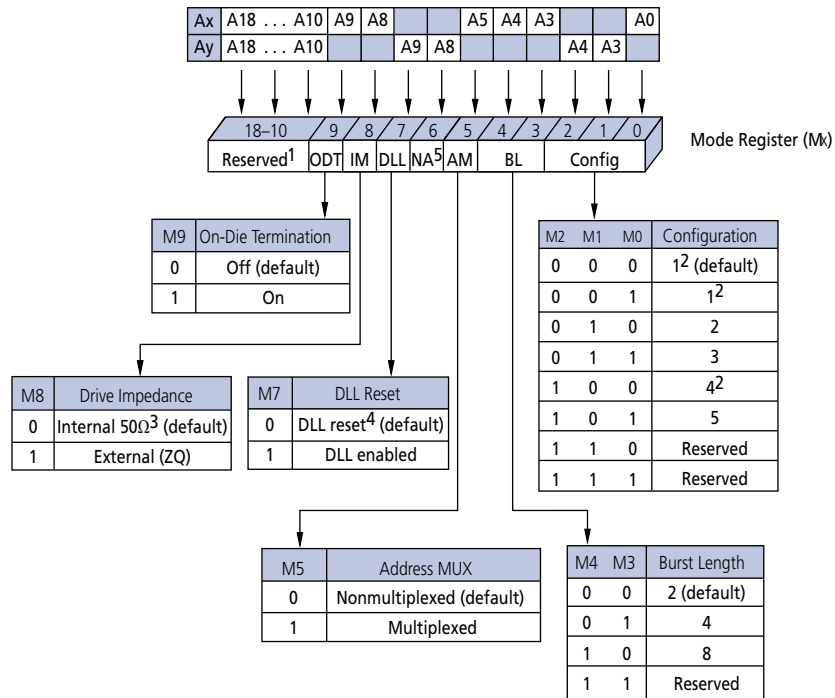

- Notes:
1. Bits A10–A18 must be set to zero.
 2. BL = 8 is not available.
 3. ±30% temperature variation.
 4. DLL RESET turns the DLL off.
 5. Ay8 not used in MRS.
 6. BA0–BA2 are “Don’t Care.”
 7. Addresses A0, A3, A4, A5, A8, and A9 must be set as shown in order to activate the mode register in the multiplexed address mode.



Table 24: Address Mapping in Multiplexed Address Mode

Data Width	Burst Length	Ball	Address										
			A0	A3	A4	A5	A8	A9	A10	A13	A14	A17	A18
x36	2	Ax	A0	A3	A4	A5	A8	A9	A10	A13	A14	A17	A18
		Ay	X	A1	A2	X	A6	A7	X	A11	A12	A16	A15
	4	Ax	A0	A3	A4	A5	A8	A9	A10	A13	A14	A17	X
		Ay	X	A1	A2	X	A6	A7	X	A11	A12	A16	A15
	8	Ax	A0	A3	A4	A5	A8	A9	A10	A13	A14	X	X
		Ay	X	A1	A2	X	A6	A7	X	A11	A12	A16	A15
x18	2	Ax	A0	A3	A4	A5	A8	A9	A10	A13	A14	A17	A18
		Ay	X	A1	A2	X	A6	A7	A19	A11	A12	A16	A15
	4	Ax	A0	A3	A4	A5	A8	A9	A10	A13	A14	A17	A18
		Ay	X	A1	A2	X	A6	A7	X	A11	A12	A16	A15
	8	Ax	A0	A3	A4	A5	A8	A9	A10	A13	A14	A17	X
		Ay	X	A1	A2	X	A6	A7	X	A11	A12	A16	A15
x9	2	Ax	A0	A3	A4	A5	A8	A9	A10	A13	A14	A17	A18
		Ay	A20	A1	A2	X	A6	A7	A19	A11	A12	A16	A15
	4	Ax	A0	A3	A4	A5	A8	A9	A10	A13	A14	A17	A18
		Ay	X	A1	A2	X	A6	A7	A19	A11	A12	A16	A15
	8	Ax	A0	A3	A4	A5	A8	A9	A10	A13	A14	A17	A18
		Ay	X	A1	A2	X	A6	A7	X	A11	A12	A16	A15

Note: 1. X = "Don't Care."

Configuration Tables

In multiplexed address mode, the READ and WRITE latencies are increased by one clock cycle. However, the device cycle time remains the same as when in nonmultiplexed address mode.

Table 25: Cycle Time and READ/WRITE Latency Configuration in Multiplexed Mode

Note 1 applies to entire table

Parameter	Configuration					Units
	1 ³	2	3	4 ^{2, 3}	5	
t _{RC}	4	6	8	3	5	t _{CK}
t _{RL}	5	7	9	4	6	t _{CK}
t _{WL}	6	8	10	5	7	t _{CK}
Valid frequency range	266–175	400–175	533–175	200–175	333–175	MHz

- Notes:
1. t_{RC} < 20ns in any configuration is only available with -25E and -18 speed grades.
 2. BL = 8 is not available.
 3. The minimum t_{RC} is typically 3 cycles, except in the case of a WRITE followed by a READ to the same bank. In this instance the minimum t_{RC} is 4 cycles.

REFRESH Command in Multiplexed Address Mode

Similar to other commands when in multiplexed address mode, AREF is executed on the rising clock edge following the one on which the command is issued. However, because only the bank address is required for AREF, the next command can be applied on the following clock. The operation of the AREF command and any other command is represented in the following figure.

Figure 41: Burst REFRESH Operation with Multiplexed Addressing

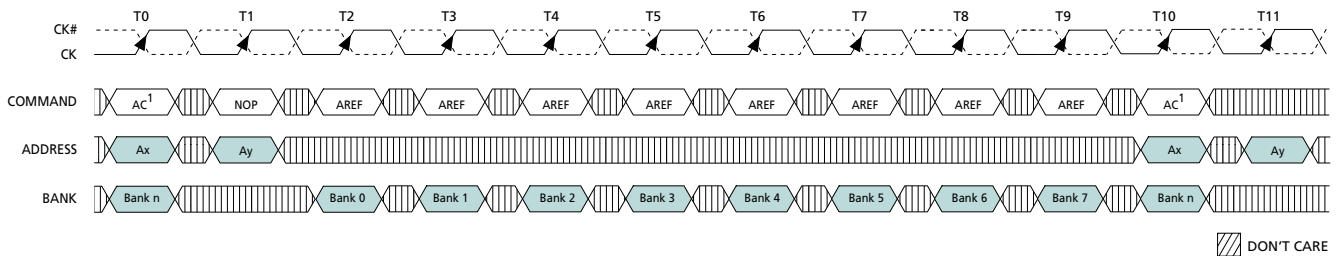

- Notes:
1. Any command.
 2. Bank *n* is chosen so that t_{RC} is met.

Figure 42: Consecutive WRITE Bursts with Multiplexed Addressing

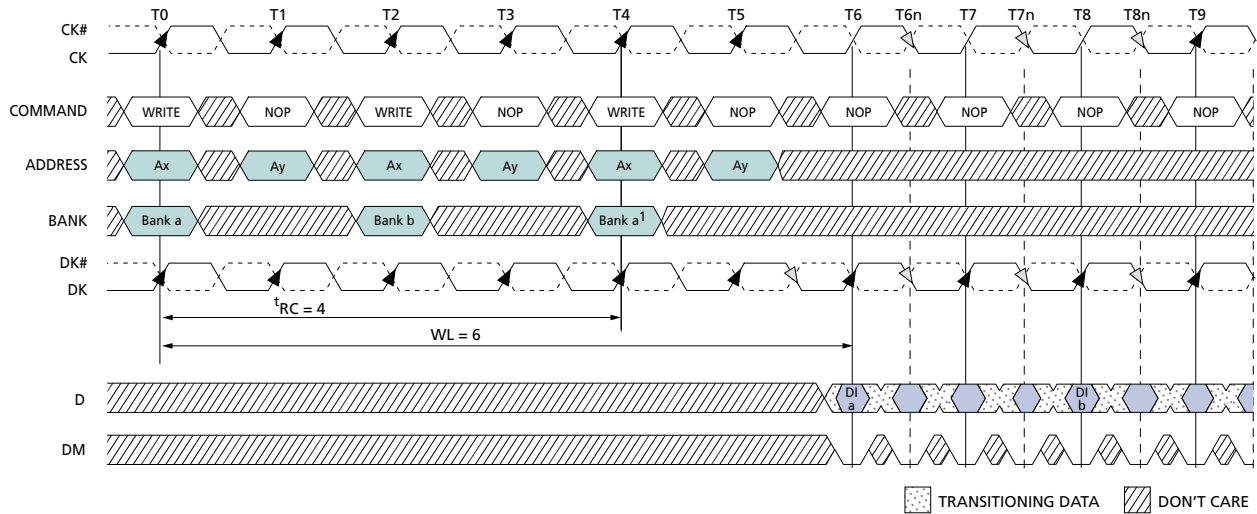

- Notes:
1. Data from the second WRITE command to bank a will appear on subsequent clock cycles that are not shown.
 2. DI a = data-in for bank a; DI b = data-in for bank b.
 3. Three subsequent elements of the burst are applied following DI for each bank.
 4. Each WRITE command may be to any bank; if the second WRITE is to the same bank, t_{RC} must be met.

Figure 43: WRITE-to-READ with Multiplexed Addressing

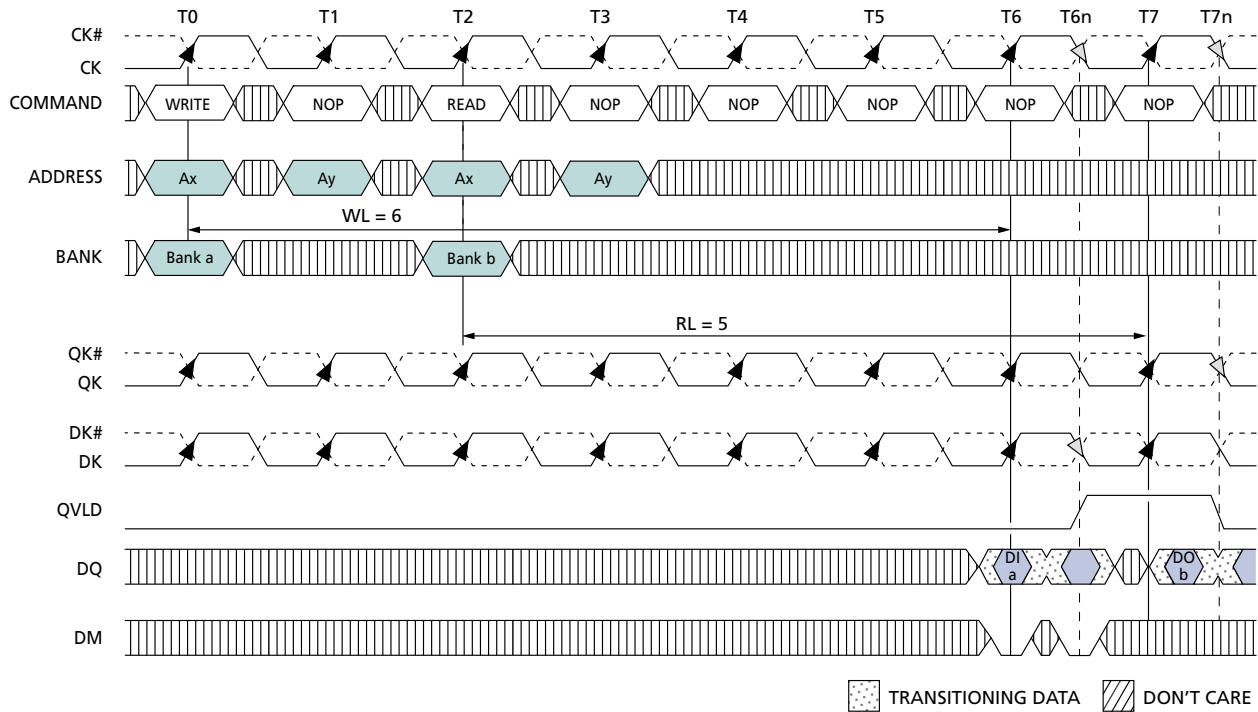

- Notes:
1. DI *a* = data-in for bank *a*.
 2. DO *b* = data-out from bank *b*.
 3. One subsequent element of each burst follows DI *a* and DO *b*.
 4. BL = 2.
 5. Nominal conditions are assumed for specifications not defined.
 6. Bank address can be to any bank, but the subsequent READ can only be to the same bank if t_{RC} has been met.

Figure 44: Consecutive READ Bursts with Multiplexed Addressing

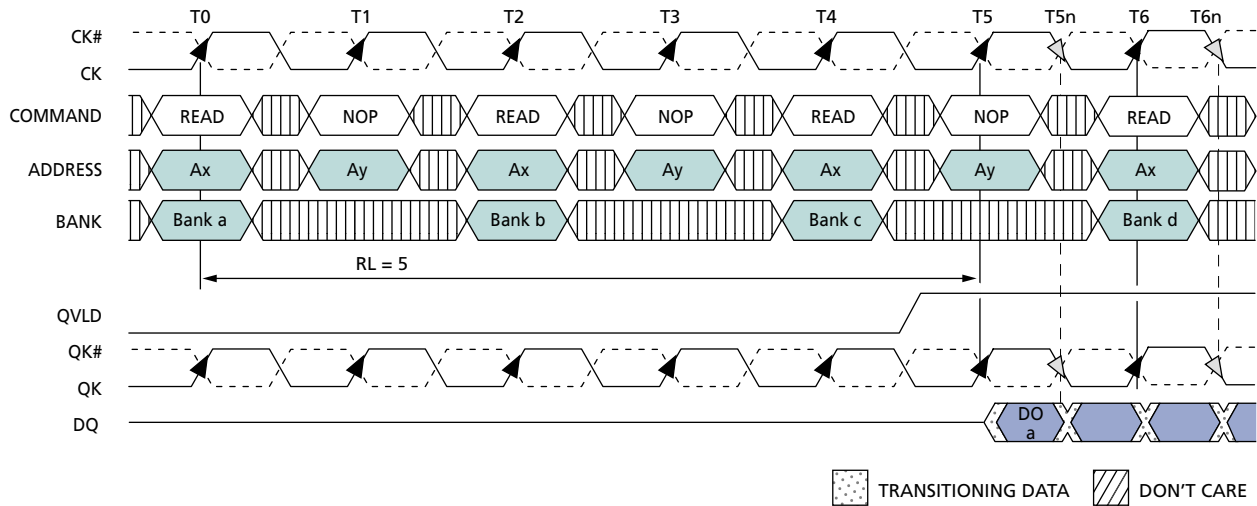

- Notes:
1. DO a = data-out from bank a.
 2. Nominal conditions are assumed for specifications not defined.
 3. BL = 4.
 4. Three subsequent elements of the burst appear following DO a.
 5. Example applies only when READ commands are issued to same device.
 6. Bank address can be to any bank, but the subsequent READ can only be to the same bank if t_{RC} has been met.
 7. Data from the READ commands to banks b through bank d will appear on subsequent clock cycles (not shown).

Figure 45: READ-to-WRITE with Multiplexed Addressing

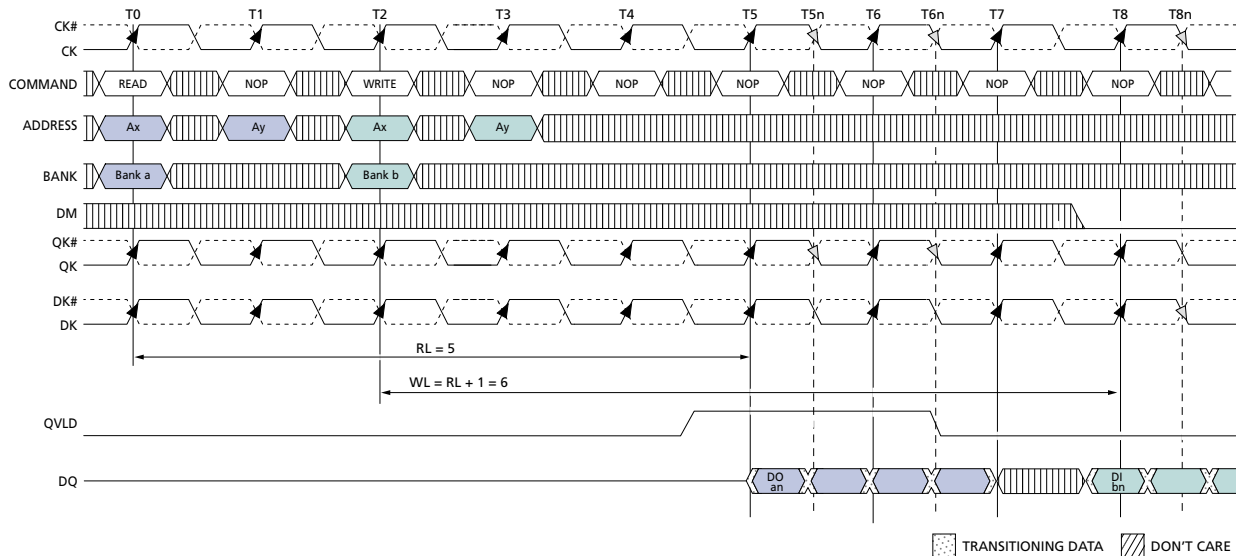

- Notes:
1. DO *an* = data-out from bank *a*.
 2. DI *bn* = data-in for bank *b*.
 3. Nominal conditions are assumed for specifications not defined.
 4. BL = 4.
 5. Three subsequent elements of the burst are applied following DO *an*.
 6. Three subsequent elements of the burst which appear following DI *bn* are not all shown.
 7. Bank address can be to any bank, but the WRITE command can only be to the same bank if t_{RC} has been met.

IEEE 1149.1 Serial Boundary Scan (JTAG)

RLDRAM incorporates a serial boundary-scan test access port (TAP) for testing connectivity once it has been mounted on a printed circuit board (PCB). As the complexity of PCB high-density surface mounting techniques increase, the boundary-scan architecture is a valuable resource for interconnectivity debug. This port operates in accordance with IEEE Standard 1149.1-2001 (JTAG) with the exception of the ZQ pin. To ensure proper boundary-scan testing of the ZQ pin, MRS bit M8 needs to be set to 0 until the JTAG testing of the pin is complete.

Note: Upon power up, the default state of MRS bit M8 is LOW.

If the device boundary scan register is to be used upon power-up and prior to device initialization, it is imperative that the CK and CK# pins meet $V_{ID(DC)}$ or CS# be held HIGH from power up until testing. Not doing so could result in inadvertent MRS commands being loaded and subsequently causing unexpected results from address pins that are dependent upon the state of the mode register. If these measures cannot be taken, the part must be initialized prior to boundary scan testing. If a full initialization is not practical or feasible prior to boundary scan testing, a single MRS command with desired settings may be issued instead. After the single MRS command is issued, the M^{RSC} parameter must be satisfied prior to boundary scan testing.

The input signals of the test access port (TDI, TMS, and TCK) use V_{DD} as a supply, while the output signal of the TAP (TDO) uses V_{DDQ} .

The JTAG test access port utilizes the device TAP controller, from which the instruction register, boundary scan register, bypass register, and ID register can be selected.

Disabling the JTAG Feature

It is possible to operate the device without using the JTAG feature. To disable the TAP controller, TCK must be tied LOW (V_{SS}) to prevent clocking of the device. TDI and TMS are internally pulled up and may be unconnected. They may alternately be connected to V_{DD} through a pull-up resistor. TDO should be left unconnected. Upon power-up, the device will come up in a reset state, which will not interfere with the operation of the device.

Test Access Port (TAP)

Test Clock (TCK)

The test clock is used only with the TAP controller. All inputs are captured on the rising edge of TCK. All outputs are driven from the falling edge of TCK.

Test Mode Select (TMS)

The TMS input is used to give commands to the TAP controller and is sampled on the rising edge of TCK.

All of the states in the TAP Controller State Diagram are entered through the serial input of the TMS pin. A 0 in the diagram represents a LOW on the TMS pin during the rising edge of TCK while a 1 represents a HIGH on TMS.

Test Data-In (TDI)

The TDI ball is used to serially input test instructions and data into the registers and can be connected to the input of any of the registers. The register between TDI and TDO is chosen by the instruction that is loaded into the TAP instruction register. For information on loading the instruction register, see TAP Controller State Diagram. TDI is connected to the most significant bit (MSB) of any register (see TAP Controller Block Diagram).

Test Data-Out (TDO)

The TDO output ball is used to serially clock test instructions and data out from the registers. The TDO output driver is only active during the Shift-IR and Shift-DR TAP controller states. In all other states, the TDO pin is in a High-Z state. The output changes on the falling edge of TCK. TDO is connected to the least significant bit (LSB) of any register (see the TAP Controller Block Diagram).

TAP Controller

The TAP controller is a finite state machine that uses the state of the TMS pin at the rising edge of TCK to navigate through its various modes of operation. See the TAP Controller State Diagram.

Test-Logic-Reset

The test-logic-reset controller state is entered when TMS is held HIGH for at least five consecutive rising edges of TCK. As long as TMS remains HIGH, the TAP controller will remain in the test-logic-reset state. The test logic is inactive during this state.

Run-Test/Idle

The run-test/idle is a controller state in-between scan operations. This state can be maintained by holding TMS LOW. From here either the data register scan, or subsequently, the instruction register scan, can be selected.

Select-DR-Scan

Select-DR-scan is a temporary controller state. All test data registers retain their previous state while here.

Capture-DR

The capture-DR state is where the data is parallel-loaded into the test data registers. If the boundary scan register is the currently selected register, then the data currently on the pins is latched into the test data registers.

Shift-DR

Data is shifted serially through the data register while in this state. As new data is input through the TDI pin, data is shifted out of the TDO pin.

Exit1-DR, Pause-DR, and Exit2-DR

The purpose of exit1-DR is used to provide a path to return back to the run-test/idle state (through the update-DR state). The pause-DR state is entered when the shifting of data through the test registers needs to be suspended. When shifting is to reconvene, the controller enters the exit2-DR state and then can re-enter the shift-DR state.

Update-DR

When the EXTEST instruction is selected, there are latched parallel outputs of the boundary-scan shift register that only change state during the update-DR controller state.

Instruction Register States

The instruction register states of the TAP controller are similar to the data register states. The desired instruction is serially shifted into the instruction register during the shift-IR state and is loaded during the update-IR state.

Figure 46: TAP Controller State Diagram

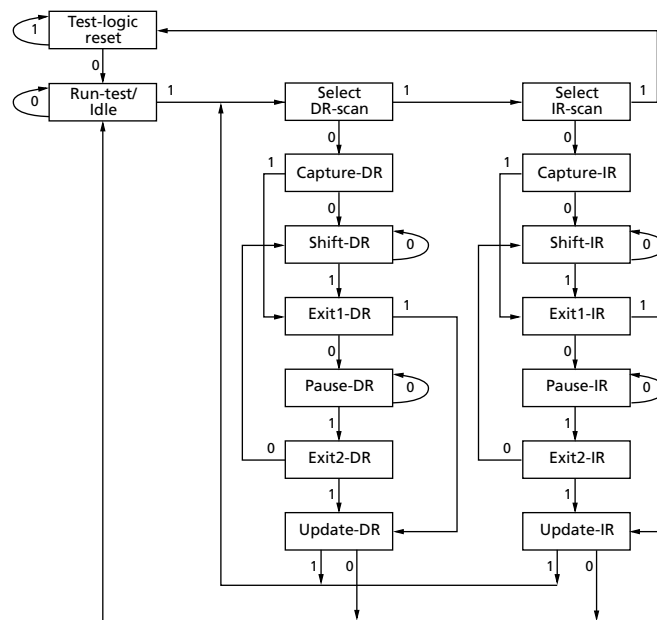
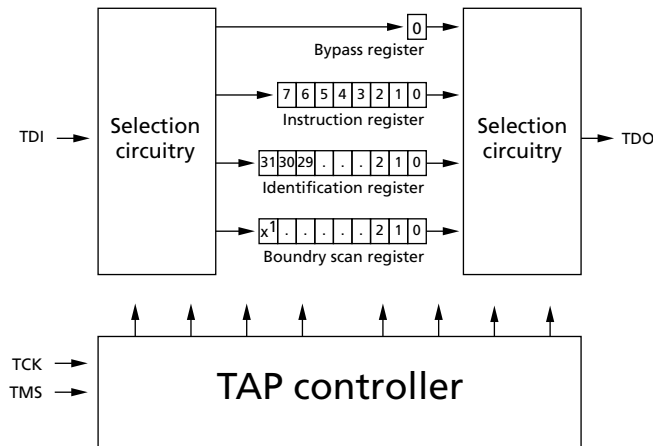

Figure 47: TAP Controller Block Diagram



Note: 1. x = 112 for all configurations.

TAP Reset

A reset is performed by forcing TMS HIGH (V_{DDQ}) for five rising edges of TCK. The reset does not affect the operation of the device and may be performed while it is operating. At power-up, the TAP is reset internally to ensure that TDO comes up in a High-Z state.

TAP Registers

Registers are connected between the TDI and TDO balls and allow data to be scanned into and out of the device test circuitry. Only one register can be selected at a time through the instruction register. Data is serially loaded into the TDI ball on the rising edge of TCK. Data is output on the TDO ball on the falling edge of TCK.

Instruction Register

Eight-bit instructions can be serially loaded into the instruction register. This register is loaded during the update-IR state of the TAP controller. Upon power-up, the instruction register is loaded with the IDCODE instruction. It is also loaded with the IDCODE instruction if the controller is placed in a reset state as described in the previous section.

When the TAP controller is in the capture-IR state, the two least significant bits are loaded with a binary 01 pattern to allow for fault isolation of the board-level serial test data path.

Bypass Register

To save time when serially shifting data through registers, it is sometimes advantageous to skip certain chips. The bypass register is a single-bit register that can be placed between the TDI and TDO balls. This allows data to be shifted through the device with minimal delay. The bypass register is set LOW (V_{SS}) when the BYPASS instruction is executed.

Boundary Scan Register

The boundary scan register is connected to all the input and bidirectional balls on the device. Several balls are also included in the scan register to reserved balls. The device has a 113-bit register.

The boundary scan register is loaded with the contents of the RAM I/O ring when the TAP controller is in the capture-DR state and is then placed between the TDI and TDO balls when the controller is moved to the shift-DR state.

The Boundary Scan (Exit) Order table shows the order in which the bits are connected. Each bit corresponds to one of the balls on the device package. The most significant bit of the register is connected to TDI, and the least significant bit is connected to TDO.

Identification (ID) Register

The ID register is loaded with a vendor-specific, 32-bit code during the capture-DR state when the IDCODE command is loaded in the instruction register. The IDCODE is hardwired into the device and can be shifted out when the TAP controller is in the shift-DR state. The ID register has a vendor code and other information described in the Identification Register Definitions table.

TAP Instruction Set

Many different TAP instructions (2^8) are possible with the 8-bit instruction register. All combinations used are listed in the table below, followed by detailed descriptions. Remaining instructions are reserved and should not be used. The TAP controller used is fully compliant to the 1149.1 convention.

Instructions are loaded into the TAP controller during the shift-IR state when the instruction register is placed between TDI and TDO. During this state, instructions are shifted through the instruction register through the TDI and TDO balls. To execute the instruction once it is shifted in, the TAP controller needs to be moved into the update-IR state.

Table 26: Instruction Codes

Instruction	Code	Description
EXTEST	0000 0000	Captures I/O ring contents; Places the boundary scan register between TDI and TDO; This operation does not affect device operations
IDCODE	0010 0001	Loads the ID register with the vendor ID code and places the register between TDI and TDO; This operation does not affect device operations
SAMPLE/PRELOAD	0000 0101	Captures I/O ring contents; Places the boundary scan register between TDI and TDO
CLAMP	0000 0111	Selects the bypass register to be connected between TDI and TDO; Data driven by output balls are determined from values held in the boundary scan register
High-Z	0000 0011	Selects the bypass register to be connected between TDI and TDO; All outputs are forced into High-Z
BYPASS	1111 1111	Places the bypass register between TDI and TDO; This operation does not affect device operations

EXTEST

The EXTEST instruction allows circuitry external to the component package to be tested. Boundary-scan register cells at output balls are used to apply a test vector, while those at input balls capture test results. Typically, the first test vector to be applied using the EXTEST instruction will be shifted into the boundary scan register using the PRELOAD instruction. Thus, during the update-IR state of EXTEST, the output driver is turned on, and the PRELOAD data is driven onto the output balls.

IDCODE

The IDCODE instruction causes a vendor-specific, 32-bit code to be loaded into the instruction register. It also places the instruction register between the TDI and TDO balls and allows the IDCODE to be shifted out of the device when the TAP controller enters the shift-DR state. The IDCODE instruction is loaded into the instruction register upon power-up or whenever the TAP controller is given a test logic reset state.

SAMPLE/PRELOAD

When the SAMPLE/PRELOAD instruction is loaded into the instruction register and the TAP controller is in the capture-DR state, a snapshot of data on the inputs and bidirectional balls is captured in the boundary scan register.

The user must be aware that the TAP controller clock can only operate at a frequency up to 50 MHz, while the RLDRAM clock operates significantly faster. Because there is a large difference between the clock frequencies, it is possible that during the capture-DR state, an input or output will undergo a transition. The TAP may then try to capture a signal while in transition (metastable state). This will not harm the device, but there is no guarantee as to the value that will be captured. Repeatable results may not be possible.

To ensure that the boundary scan register will capture the correct value of a signal, the signal must be stabilized long enough to meet the TAP controller's capture setup plus hold time (t_{CS} plus t_{CH}). The RLDRAM clock input might not be captured correctly if there is no way in a design to stop (or slow) the clock during a SAMPLE/PRELOAD instruction. If this is an issue, it is still possible to capture all other signals and simply ignore the value of the CK and CK# captured in the boundary scan register.

Once the data is captured, it is possible to shift out the data by putting the TAP into the shift-DR state. This places the boundary scan register between the TDI and TDO balls.

CLAMP

When the CLAMP instruction is loaded into the instruction register, the data driven by the output balls are determined from the values held in the boundary scan register.

High-Z

The High-Z instruction causes the boundary scan register to be connected between the TDI and TDO. This places all outputs into a High-Z state.

BYPASS

When the BYPASS instruction is loaded in the instruction register and the TAP is placed in a shift-DR state, the bypass register is placed between TDI and TDO. The advantage of the BYPASS instruction is that it shortens the boundary scan path when multiple devices are connected together on a board.

Reserved for Future Use

The remaining instructions are not implemented but are reserved for future use. Do not use these instructions.

Figure 48: JTAG Operation – Loading Instruction Code and Shifting Out Data

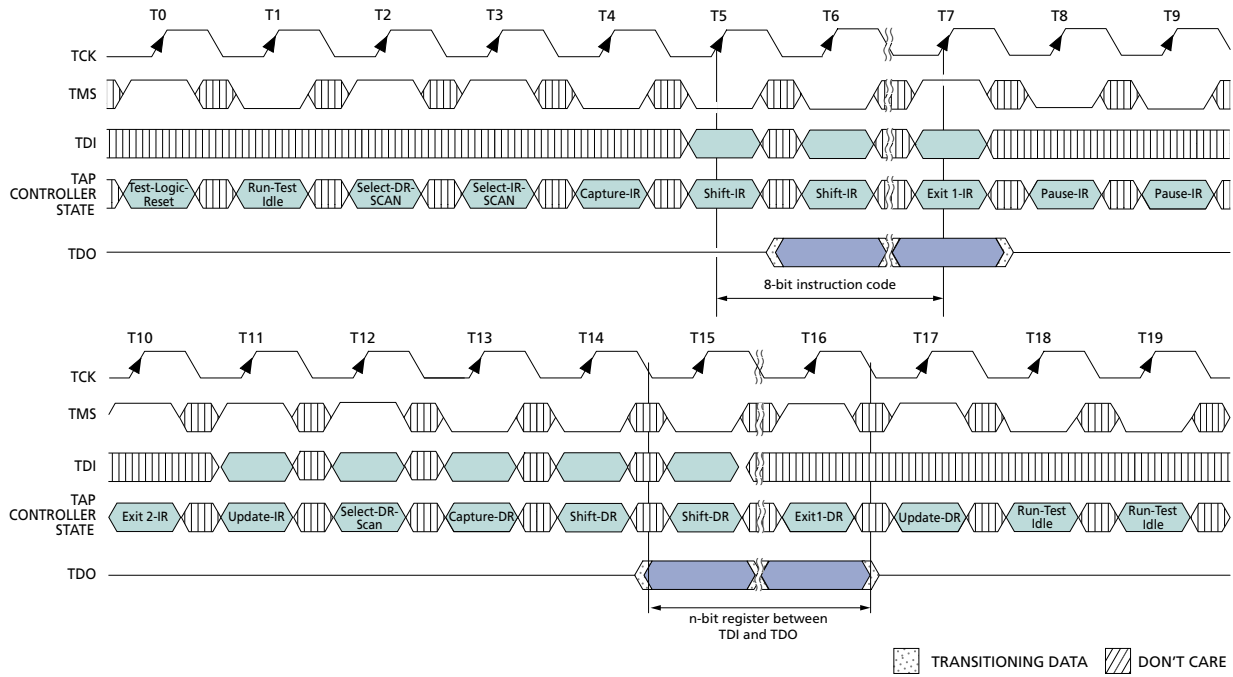

Figure 49: TAP Timing

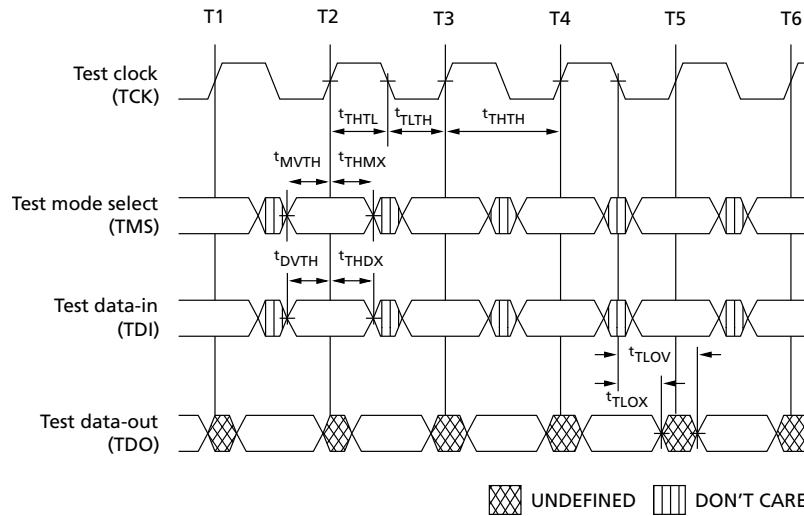

Table 27: TAP Input AC Logic Levels
 $0^{\circ}\text{C} \leq T_C \leq +95^{\circ}\text{C}; +1.7\text{V} \leq V_{DD} \leq +1.9\text{V}$, unless otherwise noted

Description	Symbol	Min	Max	Units
Input high (logic 1) voltage	V_{IH}	$V_{REF} + 0.3$	–	V
Input low (logic 0) voltage	V_{IL}	–	$V_{REF} - 0.3$	V

Note: 1. All voltages referenced to Vss (GND).

Table 28: TAP AC Electrical Characteristics
 $0^{\circ}\text{C} \leq T_C \leq +95^{\circ}\text{C}; +1.7\text{V} \leq V_{DD} \leq +1.9\text{V}$

Description	Symbol	Min	Max	Units
Clock				
Clock cycle time	t_{THTH}	20		ns
Clock frequency	f_{TF}		50	MHz
Clock HIGH time	t_{THTL}	10		ns
Clock LOW time	t_{TLTH}	10		ns
TDI/TDO times				
TCK LOW to TDO unknown	t_{TLOX}	0		ns
TCK LOW to TDO valid	t_{TLOV}		10	ns
TDI valid to TCK HIGH	t_{DVTH}	5		ns
TCK HIGH to TDI invalid	t_{THDX}	5		ns
Setup times				
TMS setup	t_{MVTH}	5		ns
Capture setup	t_{CS}	5		ns
Hold times				
TMS hold	t_{THMX}	5		ns
Capture hold	t_{CH}	5		ns

 Note: 1. t_{CS} and t_{CH} refer to the setup and hold time requirements of latching data from the boundary scan register.

Table 29: TAP DC Electrical Characteristics and Operating Conditions
 $0^{\circ}\text{C} \leq T_C \leq +95^{\circ}\text{C}; +1.7\text{V} \leq V_{DD} \leq +1.9\text{V}$, unless otherwise noted

Description	Condition	Symbol	Min	Max	Units	Notes
Input high (logic 1) voltage	–	V_{IH}	$V_{REF} + 0.15$	$V_{DD} + 0.3$	V	1, 2
Input low (logic 0) voltage	–	V_{IL}	$V_{SSQ} - 0.3$	$V_{REF} - 0.15$	V	1, 2
Input leakage current	$0\text{V} \leq V_{IN} \leq V_{DD}$	I_{LI}	–5.0	5.0	μA	
Output leakage current	Output disabled, $0\text{V} \leq V_{IN} \leq V_{DDQ}$	I_{LO}	–5.0	5.0	μA	
Output low voltage	$I_{OLc} = 100\mu\text{A}$	V_{OL1}		0.2	V	1
Output low voltage	$I_{OLt} = 2\text{mA}$	V_{OL2}		0.4	V	1
Output high voltage	$ I_{OHc} = 100\mu\text{A}$	V_{OH1}	$V_{DDQ} - 0.2$		V	1
Output high voltage	$ I_{OHt} = 2\text{mA}$	V_{OH2}	$V_{DDQ} - 0.4$		V	1

- Notes: 1. All voltages referenced to Vss (GND).
 2. Overshoot = $V_{IH(AC)} \leq V_{DD} + 0.7\text{V}$ for $t \leq t_{CK/2}$; undershoot = $V_{IL(AC)} \geq -0.5\text{V}$ for $t \leq t_{CK/2}$; during normal operation, V_{DDQ} must not exceed V_{DD} .

Table 30: Identification Register Definitions

Instruction Field	All Devices	Description
Revision number (31:28)	abcd	ab = 00 for Die Rev. A, 01 for Die Rev. B; cd = 00 for x9, 01 for x18, 10 for x36
Device ID (27:12)	00jkidef10100111	def = 000 for 288Mb, 001 for 576Mb; i = 0 for common I/O, 1 for separate I/O; jk = 01 for RLD RAM 2, 00 for RLD RAM
Micron JEDEC ID code (11:1)	00000101100	Allows unique identification of RLD RAM vendor
ID register presence indicator (0)	1	Indicates the presence of an ID register

Table 31: Scan Register Sizes

Register Name	Bit Size
Instruction	8
Bypass	1
ID	32
Boundary scan	113

Table 32: Boundary Scan (Exit) Order

Bit#	Ball	Bit#	Ball	Bit#	Ball
1	K1	39	R11	77	C11
2	K2	40	R11	78	C11
3	L2	41	P11	79	C10

Table 32: Boundary Scan (Exit) Order (Continued)

Bit#	Ball	Bit#	Ball	Bit#	Ball
4	L1	42	P11	80	C10
5	M1	43	P10	81	B11
6	M3	44	P10	82	B11
7	M2	45	N11	83	B10
8	N1	46	N11	84	B10
9	P1	47	N10	85	B3
10	N3	48	N10	86	B3
11	N3	49	P12	87	B2
12	N2	50	N12	88	B2
13	N2	51	M11	89	C3
14	P3	52	M10	90	C3
15	P3	53	M12	91	C2
16	P2	54	L12	92	C2
17	P2	55	L11	93	D3
18	R2	56	K11	94	D3
19	R3	57	K12	95	D2
20	T2	58	J12	96	D2
21	T2	59	J11	97	E2
22	T3	60	H11	98	E2
23	T3	61	H12	99	E3
24	U2	62	G12	100	E3
25	U2	63	G10	101	F2
26	U3	64	G11	102	F2
27	U3	65	E12	103	F3
28	V2	66	F12	104	F3
29	U10	67	F10	105	E1
30	U10	68	F10	106	F1
31	U11	69	F11	107	G2
32	U11	70	F11	108	G3
33	T10	71	E10	109	G1
34	T10	72	E10	110	H1
35	T11	73	E11	111	H2
36	T11	74	E11	112	J2
37	R10	75	D11	113	J1
38	R10	76	D10	–	–

Note: 1. Any unused balls in the order will read as a logic 0.



8000 S. Federal Way, P.O. Box 6, Boise, ID 83707-0006, Tel: 208-368-4000
www.micron.com/products/support Sales inquiries: 800-932-4992
Micron and the Micron logo are trademarks of Micron Technology, Inc.
All other trademarks are the property of their respective owners.

This data sheet contains minimum and maximum limits specified over the power supply and temperature range set forth herein.
Although considered final, these specifications are subject to change, as further product development and data characterization some-
times occur.

Looking for pricing, stock, or lifecycle information?

Click below to explore more details on WIN SOURCE:

- [View MT49H8M36BM-25 IT:B TR on WIN SOURCE](#)
- [Micron Technology Inc. Information](#)

Optimize Your Supply Chain with WIN SOURCE Solutions

- ✓ Global Sourcing Solution
- ✓ Obsolete Management
- ✓ Cost Control Management
- ✓ Shortage Management
- ✓ Alternative Solution
- ✓ Excess Inventory Management