



**THE DATASHEET OF  
MSP430P337AIPJM**



# MSP430C33x, MSP430P337A MIXED SIGNAL MICROCONTROLLERS

SLAS227A – OCTOBER 1999 – REVISED JUNE 2000

- Low Supply Voltage Range 2.5 V – 5.5 V
- Low Operation Current, 400  $\mu$ A at 1 MHz, 3 V
- Ultralow-Power Consumption:
  - Standby Mode: 2  $\mu$ A
  - RAM Retention Off Mode: 0.1  $\mu$ A
- Five Power-Saving Modes
- Wake-Up From Standby Mode in 6  $\mu$ s
- 16-Bit RISC Architecture, 300 ns Instruction Cycle Time
- Single Common 32 kHz Crystal, Internal System Clock up to 3.8 MHz
- Integrated LCD Driver for up to 120 Segments
- Integrated Hardware Multiplier Performs Signed, Unsigned on Multiply, and MAC Operations for Operands up to 16  $\times$  16 Bits
- Serial Communication Interface (USART), Select Asynchronous UART or Synchronous SPI by Software
- Slope A/D Converter Using External Components
- 16-Bit Timer With Five Capture/Compare Registers
- Serial Onboard Programming
- Programmable Code Protection by Security Fuse
- Family Members Include:
  - MSP430C336 – 24 KB ROM, 1 KB RAM
  - MSP430C337 – 32 KB ROM, 1 KB RAM
  - MSP430P337A – 32 KB OTP, 1 KB RAM
- EPROM Version Available for Prototyping:
  - PMS430E337A
- Available in the Following Packages:
  - 100 Pin Quad Flat-Pack (QFP)
  - 100 Pin Ceramic Quad Flat-Pack (CFP) (EPROM Version)

## description

The Texas Instruments MSP430 is an ultralow-power mixed signal microcontroller family consisting of several devices featuring different sets of modules targeted to various applications. The controller is designed to be battery-operated for an extended application lifetime. With the 16-bit RISC architecture, 16 integrated registers on the CPU, and a constant generator, the MSP430 achieves maximum code efficiency. The digital-controlled oscillator, together with the frequency lock loop (FLL), provides a wake-up from a low-power mode to an active mode in less than 6  $\mu$ s. The MSP430x33x series microcontrollers have built-in hardware multiplication and communication capability using asynchronous (UART) and synchronous protocols.

Typical applications of the MSP430 family include electronic gas, water, and electric meters and other sensor systems that capture analog signals, convert them to digital values, process, displays, or transmits data to a host system.

AVAILABLE OPTIONS

T <sub>A</sub>	PACKAGED DEVICES	
	PLASTIC QFP (PJM)	CERAMIC QFP (HFD)
–40°C to 85°C	MSP430C336IPJM MSP430C337IPJM MSP430P337AIPJM	—
25°C	—	PMS430E337AHFD



Please be aware that an important notice concerning availability, standard warranty, and use in critical applications of Texas Instruments semiconductor products and disclaimers thereto appears at the end of this data sheet.

PRODUCTION DATA information is current as of publication date. Products conform to specifications per the terms of Texas Instruments standard warranty. Production processing does not necessarily include testing of all parameters.

 **TEXAS  
INSTRUMENTS**

POST OFFICE BOX 655303 • DALLAS, TEXAS 75265

Copyright © 2000, Texas Instruments Incorporated

# MSP430C33x, MSP430P337A MIXED SIGNAL MICROCONTROLLERS

SLAS227A – OCTOBER 1999 – REVISED JUNE 2000

## PJM or HFD PACKAGE (TOP VIEW)

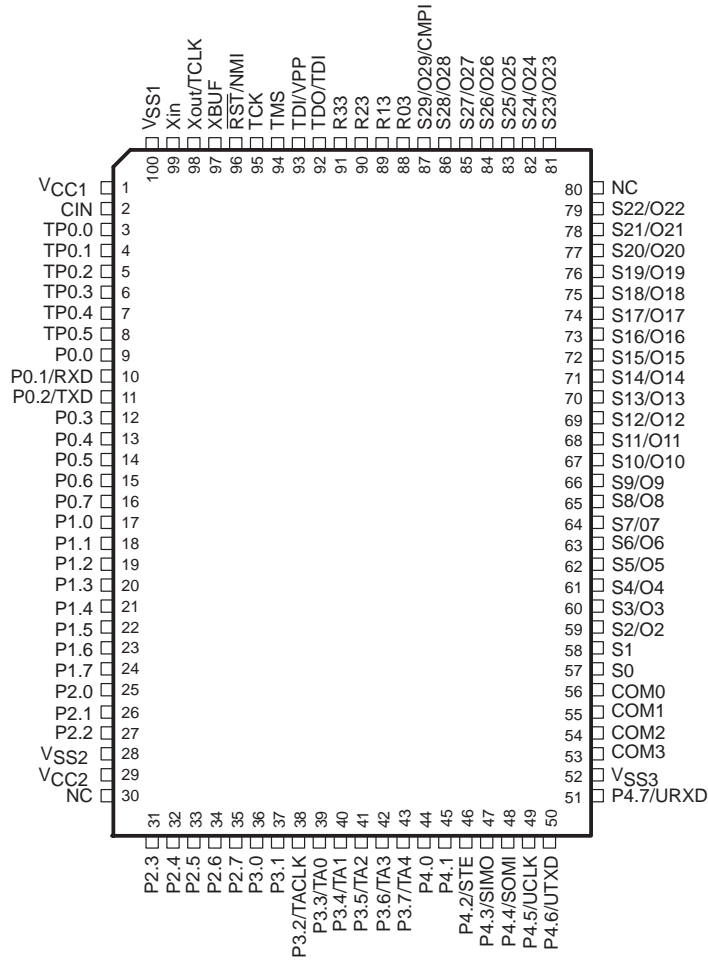

NC – No internal connection



POST OFFICE BOX 655303 • DALLAS, TEXAS 75265

## functional block diagram

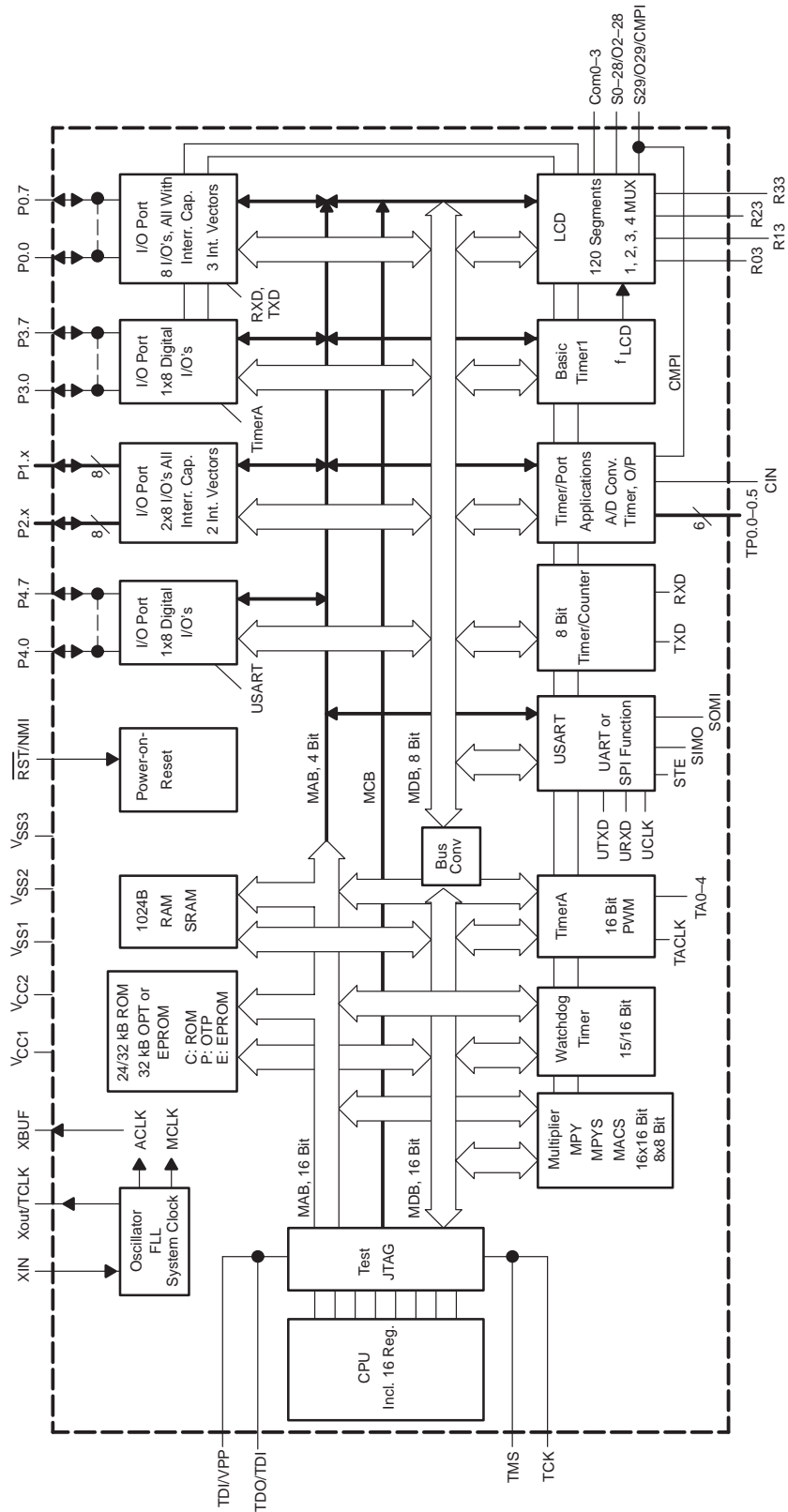

# MSP430C33x, MSP430P337A MIXED SIGNAL MICROCONTROLLERS

SLAS227A – OCTOBER 1999 – REVISED JUNE 2000

## Terminal Functions

TERMINAL NAME	NO.	I/O	DESCRIPTION
CIN	2	I	Input port. CIN is used as an enable for counter TPCNT1 – (Timer/Port).
COM0-3	56-53	O	Common outputs. COM0-3 are used for LCD backplanes – LCD
P0.0	9	I/O	General-purpose digital I/O
P0.1/RXD	10	I/O	General-purpose digital I/O, receive digital Input port – 8-Bit Timer/Counter
P0.2/TXD	11	I/O	General-purpose digital I/O, transmit data output port – 8-Bit Timer/Counter
P0.3-P0.7	12-16	I/O	Five general-purpose digital I/Os, bit 3-7
P1.0-P1.7	17-24	I/O	Eight general-purpose digital I/Os, bit 0-7
P2.0-P2.7	25-27, 31-35	I/O	Eight general-purpose digital I/Os, bit 0-7
P3.0, P3.1	36,37	I/O	Two general-purpose digital I/Os, bit 0 and bit 1
P3.2/TACLK	38	I/O	General-purpose digital I/O, clock input – Timer_A
P3.3/TA0	39	I/O	General-purpose digital I/O, capture I/O, or PWM output port – Timer_A CCR0
P3.4/TA1	40	I/O	General-purpose digital I/O, capture I/O, or PWM output port – Timer_A CCR1
P3.5/TA2	41	I/O	General-purpose digital I/O, capture I/O, or PWM output port – Timer_A CCR2
P3.6/TA3	42	I/O	General-purpose digital I/O, capture I/O, or PWM output port – Timer_A CCR3
P3.7/TA4	43	I/O	General-purpose digital I/O, capture I/O, or PWM output port – Timer_A CCR4
P4.0	44	I/O	General-purpose digital I/O, bit 0
P4.1	45	I/O	General-purpose digital I/O, bit 1
P4.2/STE	46	I/O	General-purpose digital I/O, slave transmit enable – USART/SPI mode
P4.3/SIMO	47	I/O	General-purpose digital I/O, slave in/master out – USART/SPI mode
P4.4/SOMI	48	I/O	General-purpose digital I/O, master in/slave out – USART/SPI mode
P4.5/UCLK	49	I/O	General-purpose digital I/O, external clock input – USART
P4.6/UTXD	50	I/O	General-purpose digital I/O, transmit data out – USART/UART mode
P4.7/URXD	51	I/O	General-purpose digital I/O, receive data in – USART/UART mode
R03	88	I	Input port of fourth positive (lowest) analog LCD level (V5) – LCD
R13	89	I	Input port of third most positive analog LCD level (V3 of V4) – LCD
R23	90	I	Input port of second most positive analog LCD level (V2) – LCD
R33	91	O	Output of most positive analog LCD level (V1) – LCD
RST/NMI	96	I	Reset input or non-maskable interrupt input port
S0	57	O	Segment line S0 – LCD
S1	58	O	Segment line S1 – LCD
S2/O2-S5/O5	59-62	O	Segment lines S2 to S5 or digital output ports, O2-O5, group 1 – LCD
S6/O6-S9/O9	63-66	O	Segment lines S6 to S9 or digital output ports O6-O9, group 2 – LCD
S10/O10-S13/O13	67-70	O	Segment lines S10 to S13 or digital output ports O10-O13, group 3 – LCD
S14/O14-S17/O17	71-74	O	Segment lines S14 to S17 or digital output ports O14-O17, group 4 – LCD
S18/O18-S21/O21	75-78	O	Segment lines S18 to S21 or digital output ports O18-O21, group 5 – LCD
S22/O22-S25/O25	79, 81-83	O	Segment line S22 to S25 or digital output ports O22-O25, group 6 – LCD
S26/O26-S29/O29/CMPI	84-87	O	Segment line S26 to S29 or digital output ports O26-O29, group 7 – LCD. Segment line S29 can be used as comparator input port CMPI – Timer/Port
TCK	95	I	Test clock. TCK is the clock input port for device programming and test.
TDI/VPP	93	I	Test data input. TDI/VPP is used as a data input port or input for programming voltage.



**Terminal Functions (Continued)**

TERMINAL NAME	NO.	I/O	DESCRIPTION
TMS	94	I	Test mode select. TMS is used as an input port for device programming and test.
TDO/TDI	92	I/O	Test data output port. TDO/TDI data output or programming data input terminal
TP0.0	3	O	General-purpose 3-state digital output port, bit 0 – Timer/Port
TP0.1	4	O	General-purpose 3-state digital output port, bit 1 – Timer/Port
TP0.2	5	O	General-purpose 3-state digital output port, bit 2 – Timer/Port
TP0.3	6	O	General-purpose 3-state digital output port, bit 3 – Timer/Port
TP0.4	7	O	General-purpose 3-state digital output port, bit 4 – Timer/Port
TP0.5	8	I/O	General-purpose 3-state digital input/output port, bit 5 – Timer/Port
V <sub>CC1</sub>	1		Positive supply voltage
V <sub>CC2</sub>	29		Positive supply voltage
V <sub>SS1</sub>	100		Ground reference
V <sub>SS2</sub>	28		Ground reference
V <sub>SS3</sub>	52		Ground reference
XBUF	97	O	System clock (MCLK) or crystal clock (ACLK) output
Xin	99	I	Input port for crystal oscillator
Xout/TCLK	98	I/O	Output terminal of crystal oscillator or test clock input

**detailed description**

**processing unit**

The processing unit is based on a consistent and orthogonal designed CPU and instruction set. This design structure results in a RISC-like architecture, highly transparent to the application development, which is distinguished by ease of programming. All operations other than program-flow instructions consequently are performed as register operations in conjunction with seven addressing modes for source and four modes for destination operand.

**CPU registers**

The CPU has sixteen registers that provide reduced instruction execution time. This reduces the register-to-register operation execution time to one cycle of the processor frequency.

Four of the registers are reserved for special use as a program counter, a stack pointer, a status register, and a constant generator. The remaining registers are available as general-purpose registers.

Peripherals are connected to the CPU using a data address and control bus and can be handled easily with all instructions for memory manipulation.

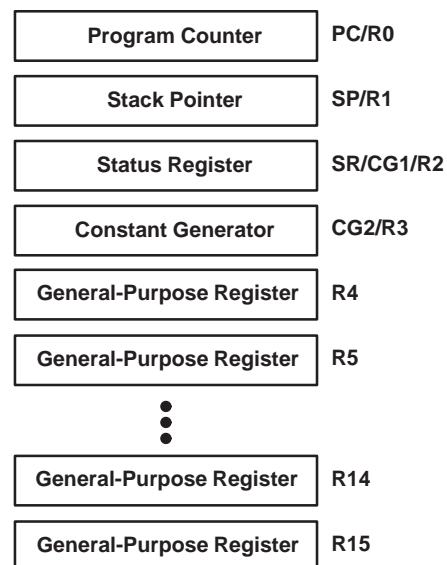

# MSP430C33x, MSP430P337A MIXED SIGNAL MICROCONTROLLERS

SLAS227A – OCTOBER 1999 – REVISED JUNE 2000

## detailed description (continued)

### instruction set

The instruction set for this register-register architecture provides a powerful and easy-to-use assembly language. The instruction set consists of 51 instructions with three formats and seven addressing modes. Table 1 provides a summation and example of the three types of instruction formats; the address modes are listed in Table 2.

**Table 1. Instruction Word Formats**

Dual operands, source-destination	e.g. ADD R4,R5	R4 + R5 → R5
Single operands, destination only	e.g. CALL R8	PC → (TOS), R8 → PC
Relative jump, un-/conditional	e.g. JNE	Jump-on equal bit = 0

Instructions that can operate on both word and byte data are differentiated by the suffix .B when a byte operation is required.

Examples:	Instructions for word operation:	Instructions for byte operation:
	MOV EDE,TONI	MOV.B EDE,TONI
	ADD #235h,&MEM	ADD.B #35h,&MEM
	PUSH R5	PUSH.B R5
	SWPB R5	—

**Table 2. Address Mode Descriptions**

ADDRESS MODE	S	D	SYNTAX	EXAMPLE	OPERATION
Register	√	√	MOV Rs,Rd	MOV R10,R11	R10 → R11
Indexed	√	√	MOV X(Rn),Y(Rm)	MOV 2(R5),6(R6)	M(2+R5) → M(6+R6)
Symbolic (PC relative)	√	√	MOV EDE,TONI		M(EDE) → M(TONI)
Absolute	√	√	MOV &MEM,&TCDAT		M(MEM) → M(TCDAT)
Indirect	√		MOV @Rn,Y(Rm)	MOV @R10,Tab(R6)	M(R10) → M(Tab+R6)
Indirect autoincrement	√		MOV @Rn+,Rm	MOV @R10+,R11	M(R10) → R11 R10 + 2 → R10
Immediate	√		MOV #X,TONI	MOV #45,TONI	#45 → M(TONI)

NOTE 1: S = source, D = destination.

Computed branches (BR) and subroutine calls (CALL) instructions use the same address modes as the other instructions. These addressing modes provide *indirect* addressing, ideally suited for computed branches and calls. The full use of this programming capability permits a program structure different from conventional 8- and 16-bit controllers. For example, numerous routines can easily be designed to deal with pointers and stacks instead of using flag type programs for flow control.



## operation modes and interrupts

The MSP430 operating modes support various advanced requirements for ultralow-power and ultralow-energy consumption. This is achieved by the intelligent management of the operations during the different module operation modes and CPU states. The requirements are fully supported during interrupt event handling. An interrupt event awakens the system from each of the various operating modes and returns with the RETI instruction to the mode that was selected before the interrupt event. The clocks used are ACLK and MCLK. ACLK is the crystal frequency and MCLK, a multiple of ACLK, is used as the system clock.

The following five operating modes are supported:

- Active mode (AM). The CPU is enabled with different combinations of active peripheral modules.
- Low-power mode 0 (LPM0). The CPU is disabled, peripheral operation continues, ACLK and MCLK signals are active, and loop control for MCLK is active.
- Low-power mode 1 (LPM1). The CPU is disabled, peripheral operation continues, ACLK and MCLK signals are active, and loop control for MCLK is inactive.
- Low-power mode 2 (LPM2). The CPU is disabled, peripheral operation continues, ACLK signal is active, and MCLK and loop control for MCLK are inactive.
- Low-power mode 3 (LPM3). The CPU is disabled, peripheral operation continues, ACLK signal is active, MCLK and loop control for MCLK are inactive, and the dc generator for the digital controlled oscillator (DCO) (→MCLK generator) is switched off.
- Low-power mode 4 (LPM4). The CPU is disabled, peripheral operation continues, ACLK signal is inactive (crystal oscillator stopped), MCLK and loop control for MCLK are inactive, and the dc generator for the DCO is switched off.

The special function registers (SFR) include module-enable bits that stop or enable the operation of the specific peripheral module. All registers of the peripherals may be accessed if the operational function is stopped or enabled, however, some peripheral current-saving functions are accessed through the state of local register bits. An example is the enable/disable of the analog voltage generator in the LCD peripheral, which is turned on or off using one register bit.

The most general bits that influence current consumption and support fast turnon from low power operating modes are located in the status register (SR). Four of these bits control the CPU and the system clock generator: SCG1, SCG0, OscOff, and CPUOff.

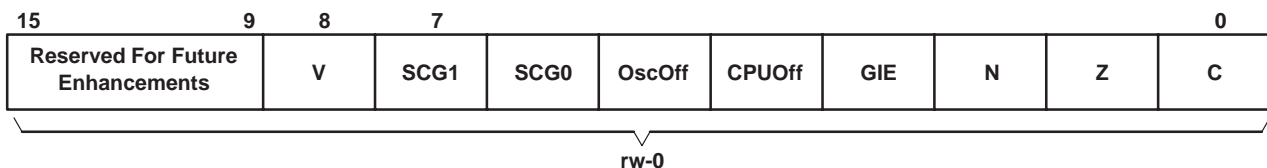

## interrupts

Software determines the activation of interrupts through the monitoring of hardware set interrupt flag status bits, the control of specific interrupt enable bits in SRs, the establishment of interrupt vectors, and the programming of interrupt handlers. The interrupt vectors and the power-up starting address are located in ROM address locations 0FFFFh through 0FFE0h. Each vector contains the 16-bit address of the appropriate interrupt handler instruction sequence. Table 3 provides a summation of interrupt functions and addresses.

# MSP430C33x, MSP430P337A MIXED SIGNAL MICROCONTROLLERS

SLAS227A – OCTOBER 1999 – REVISED JUNE 2000

## operation modes and interrupts (continued)

**Table 3. Interrupt Functions and Addresses**

INTERRUPT SOURCE	INTERRUPT FLAG	SYSTEM INTERRUPT	WORD ADDRESS	PRIORITY
Power up, external reset, watchdog	WDTIFG	Reset	0FFFEh	15, highest
NMI, Oscillator fault	NMIIFG (see Notes 2 and 4) OFIFG (see Notes 2 and 5)	Non-maskable (Non)-maskable	0FFFCh	14
Dedicated I/O P0.0	P0IFG.0	Maskable	0FFFAh	13
Dedicated I/O P0.1 or 8-Bit Timer/Counter	P0IFG.1	Maskable	0FFF8h	12
		Maskable	0FFF6h	11
Watchdog Timer	WDTIFG	Maskable	0FFF4h	10
Timer_A	CCIFG0 (see Note 3)	Maskable	0FFF2h	9
Timer_A	TAIFG (see Note 3)	Maskable	0FFF0h	8
UART receive	URXIFG	Maskable	0FFEEh	7
UART transmit	UTXIFG	Maskable	0FFEC	6
			0FFEAh	5
Timer/Port	RC1FG, RC2FG, EN1FG (see Note 3)	Maskable	0FFE8h	4
I/O port P2	P2IFG.07 (see Note 2)	Maskable	0FFE6h	3
I/O port P1	P1IFG.07 (see Note 2)	Maskable	0FFE4h	2
Basic Timer1	BTIFG	Maskable	0FFE2h	1
I/O port P0.2 – P0.7	P0IFG.27 (see Note 2)	Maskable	0FFE0h	0, lowest

- NOTES: 2. Multiple source flags  
 3. Interrupt flags are located in the individual module registers.  
 4. Non-maskable : neither the individual or the general interrupt enable bit will disable an interrupt event.  
 5. (Non)-maskable: the individual interrupt enable bit can disable an interrupt event, but the general interrupt enable bit cannot.

### special function registers

Most interrupt and module enable bits are collected into the lowest address space. Special function register bits that are not allocated to a functional purpose are not physically present in the device. Simple software access is provided with this arrangement.

#### interrupt enable 1 and 2

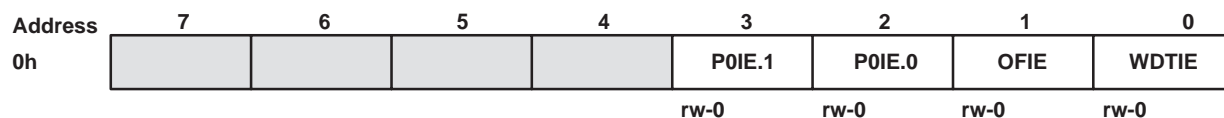

- WDTIE: Watchdog Timer interrupt enable signal  
 OFIE: Oscillator fault interrupt enable signal  
 POIE.0: Dedicated I/O P0.0 interrupt enable signal  
 POIE.1: P0.1 or 8-Bit Timer/Counter, RXD interrupt enable signal



- URXIE: USART receive interrupt enable signal  
 UTXIE: USART transmit interrupt enable signal  
 TPIE: Timer/Port interrupt enable signal  
 BTIE: Basic Timer1 interrupt enable signal



operation modes and interrupts (continued)

interrupt flag registers 1 and 2

Address	7	6	5	4	3	2	1	0
02h				NMIIFG	P0IFG.1	P0IFG.0	OFIFG	WDTIFG
				rw-0	rw-0	rw-0	rw-1	rw-0

- WDTIFG: Set on overflow or security key violation  
or  
Reset on VCC1 power-on or reset condition at  $\overline{\text{RST}}$ /NMI-pin
- OFIFG: Flag set on oscillator fault
- P0IFG.0: Dedicated I/O P0.0
- P0IFG.1: P0.1 or 8-Bit Timer/Counter, RXD
- NMIIFG: Signal at  $\overline{\text{RST}}$ /NMI-pin

Address	7	6	5	4	3	2	1	0
03h	BTIFG						UTXIFG	URXIFG
	rw						rw-1	rw-0

- URXIFG: USART receive flag
- UTXIFG: USART transmit flag
- BTIFG: Basic Timer1 flag

module enable registers 1 and 2

Address	7	6	5	4	3	2	1	0
04h								

Address	7	6	5	4	3	2	1	0
05h							UTXE	URXE/USPIE
							rw-0	rw-0

- Bit 0: USART mode: USART receive enable, URXE  
SPI mode: SPI enable, USPIE
- Bit 1: USART mode: USART transmit enable, UTXE  
SPI mode: not applicable

- Legend
- rw: Bit can be read and written
  - rw-0: Bit can be read and written. It is reset by PUC.  
SFR bit not present in device



# MSP430C33x, MSP430P337A MIXED SIGNAL MICROCONTROLLERS

SLAS227A – OCTOBER 1999 – REVISED JUNE 2000

## ROM memory organization

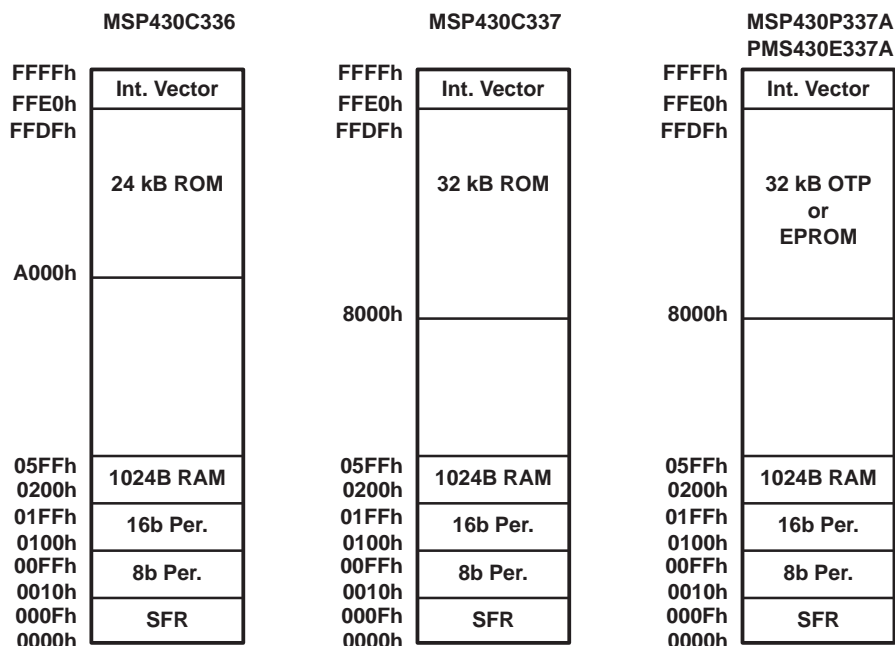

## peripherals

Peripherals that are connected to the CPU through a data, address, and controls bus can be handled easily with instructions for memory manipulation.

## oscillator and system clock

Two clocks are used in the system: the system (master) clock (MCLK) and the auxiliary clock (ACLK). The MCLK is a multiple of the ACLK. The ACLK runs with the crystal oscillator frequency. The special design of the oscillator supports the feature of low current consumption and the use of a 32 768 Hz crystal. The crystal is connected across two terminals without any other external components required.

The oscillator starts after applying VCC, due to a reset of the control bit (OscOff) in the status register (SR). It can be stopped by setting the OscOff bit to a 1. The enabled clock signals ACLK, ACLK/2, ACLK/4, or MCLK are accessible for use by external devices at output terminal XBUF.

The controller system clocks have to deal with different requirements according to the application and system condition. Requirements include:

- High frequency in order to react quickly to system hardware requests or events
- Low frequency in order to minimize current consumption, EMI, etc.
- Stable frequency for timer applications e.g., real-time clock (RTC)
- Enable start-stop operation with minimum delay to operation function

These requirements cannot all be met with fast frequency high-Q crystals or with RC-type low-Q oscillators. This compromise and selected for the MSP430, uses a low-crystal frequency, which is multiplied to achieve the desired nominal operating range:

$$f_{(\text{system})} = (N + 1) \times f_{(\text{crystal})}$$

### oscillator and system clock (continued)

The crystal frequency multiplication is achieved with a frequency locked loop (FLL) technique. The factor N is set to 31 after a power-up clear condition. The FLL technique, in combination with a digital controlled oscillator (DCO), provides immediate start-up capability together with long term crystal stability. The frequency variation of the DCO with the FLL inactive is typically 330 ppm, which means that with a cycle time of 1  $\mu$ s the maximum possible variation is 0.33 ns. For more precise timing, the FLL can be used, which forces longer cycle times if the previous cycle time was shorter than the selected one. This switching of cycle times makes it possible to meet the chosen system frequency over a long period of time.

The start-up operation of the system clock depends on the previous machine state. During a PUC, the DCO is reset to its lowest possible frequency. The control logic starts operation immediately after recognition of PUC.

### multiplication

The multiplication operation is supported by a dedicated peripheral module. The module performs 16x16, 16x8, 8x16, and 8x8 bit operations. The module is capable of supporting signed and unsigned multiplication as well as signed and unsigned multiply and accumulate operations. The result of an operation can be accessed immediately after the operands have been loaded into the peripheral registers. No additional clock cycles are required.

### digital I/O

Five eight-bit I/O ports (P0 thru P4) are implemented. Port P0 has six control registers, P1 and P2 have seven control registers, and P3 and P4 modules have four control registers to give maximum flexibility of digital input/output to the application:

- Individual I/O bits are independently programmable.
- Any combination of input, output, and interrupt conditions is possible.
- Interrupt processing of external events is fully implemented for all eight bits of the P0, P1, and P2 ports.
- Read/write access is available to all registers by all instructions.

The seven registers are:

- Input register                      contains information at the pins
- Output register                    contains output information
- Direction register                controls direction
- Interrupt edge select            contains input signal change necessary for interrupt
- Interrupt flags                    indicates if interrupt(s) are pending
- Interrupt enable                 contains interrupt enable pins
- Function select                  determines if pin(s) used by module or port

These registers contain eight bits each with the exception of the interrupt flag register and the interrupt enable register which are 6 bits each. The two least significant bit (LSBs) of the interrupt flag and enable registers are located in the special function register (SFR). Five interrupt vectors are implemented, one for Port P0.0, one for Port P0.1, one commonly used for any interrupt event on Port P0.2 to Port P0.7, one commonly used for any interrupt event on Port P1.0 to Port P1.7, and one commonly used for any interrupt event on Port P2.0 to Port P2.7.

# MSP430C33x, MSP430P337A MIXED SIGNAL MICROCONTROLLERS

SLAS227A – OCTOBER 1999 – REVISED JUNE 2000

---

## LCD drive

The liquid crystal displays (LCDs) for static, 2-, 3-, and 4-MUX operation can be driven directly. The operation of the controller LCD logic is defined by software through memory-bit manipulation. The LCD memory is part of the LCD module, not part of data memory. Eight mode and control bits define the operation and current consumption of the LCD drive. The information for the individual digits can be easily obtained using table programming techniques combined with the proper addressing mode. The segment information is stored into LCD memory using instructions for memory manipulation.

The drive capability is defined by the external resistor divider that supports analog levels for 2-, 3-, and 4-MUX operation. Groups of the LCD segment lines can be selected for digital output signals. The MSP430x33x configuration has four common lines, 30 segment lines, and four terminals for adjusting the analog levels.

## Basic Timer1

The Basic Timer1 (BT1) divides the frequency of MCLK or ACLK, as selected with the SSEL bit, to provide low-frequency control signals. This is done within the system by one central divider, the Basic Timer1, to support low current applications. The BTCTL control register contains the flags which control or select the different operational functions. When the supply voltage is applied or when a reset of the device ( $\overline{\text{RST}}/\text{NMI}$  pin), a watchdog overflow, or a watchdog security key violation occurs, all bits in the register hold undefined or unchanged status. The user software usually configures the operational conditions on the BT during initialization.

The Basic Timer1 has two eight bit timers which can be cascaded to a sixteen bit timer. Both timers can be read and written by software. Two bits in the SFR address range handle the system control interaction according to the function implemented in the Basic Timer1. These two bits are the Basic Timer1 interrupt flag (BTIFG) and the Basic Timer1 interrupt enable (BTIE) bit.

## Watchdog Timer

The primary function of the Watchdog Timer (WDT) module is to perform a controlled system restart after a software upset has occurred. If the selected time interval expires, a system reset is generated. If this watchdog function is not needed in an application, the module can work as an interval timer, which generates an interrupt after the selected time interval.

The Watchdog Timer counter (WDCNT) is a 15/16-bit upcounter which is not directly accessible by software. The WDCNT is controlled using the Watchdog Timer control register (WDTCTL), which is an 8-bit read/write register. Writing to WDTCTL, in both operating modes (watchdog or timer) is only possible by using the correct password in the high-byte. The low-byte stores data written to the WDTCTL. The high-byte password is 05Ah. If any value other than 05Ah is written to the high-byte of the WDTCTL, a system reset PUC is generated. When the password is read its value is 069h. This minimizes accidental write operations to the WDTCTL register. In addition to the Watchdog Timer control bits, there are two bits included in the WDTCTL that configure the NMI pin.

## USART

The universal synchronous/asynchronous interface is a dedicated peripheral module which provides serial communications. The USART supports synchronous SPI (3 or 4 pin) and asynchronous UART communications protocols, using double buffered transmit and receive channels. Data streams of 7 or 8 bits in length can be transferred at a rate determined by the program, or by a rate defined by an external clock. Low-power applications are optimized by UART mode options which allow for the receipt of only the first byte of a complete frame. The applications software then decides if the succeeding data is to be processed. This option reduces power consumption.

Two dedicated interrupt vectors are assigned to the USART module, one for the receive and one for the transmit channel.



POST OFFICE BOX 655303 • DALLAS, TEXAS 75265

## Timer/Port

The Timer/Port module has two 8-Bit Timer/Counters, an input that triggers one counter, and six digital outputs with 3-state capability. Both counters have an independent clock selector for selecting an external signal or one of the internal clocks (ACLK or MCLK). One of the counters has an extended control capability to halt, count continuously, or gate the counter by selecting one of two external signals. This gate signal sets the interrupt flag if an external signal is selected and the gate stops the counter.

Both timers can be read to and written from by software. The two 8-Bit Timer/Counters can be cascaded to form a 16-bit counter. A common interrupt vector is implemented. The interrupt flag can be set by three events in the 8-Bit Timer/Counter mode (gate signal or overflow from the counters) or by two events in the 16-bit counter mode (gate signal or overflow from the MSB of the cascaded counter).

## slope A/D conversion

Slope A/D conversion is accomplished with the Timer/Port module using external resistor(s) for reference ( $R_{ref}$ ), using external resistor(s) to the measured ( $R_{meas}$ ), and an external capacitor. The external components are driven by software in such a way that the internal counter measures the time that is needed to charge or discharge the capacitor. The reference resistor's ( $R_{ref}$ ) charge or discharge time is represented by  $N_{ref}$  counts. The unknown resistors ( $R_{meas}$ ) charge or discharge time is represented by  $N_{meas}$  counts. The unknown resistor's value  $R_{meas}$  is the value of  $R_{ref}$  multiplied by the relative number of counts ( $N_{meas}/N_{ref}$ ). This value determines resistive sensor values that correspond to the physical data, for example temperature, when an NTC or PTC resistor is used.

## Timer\_A

The Timer\_A module (see Figure 1) offers one sixteen bit counter and five capture/compare registers. The timer clock source can be selected to come from an external source TACLK (SSEL=0), the ACLK (SSEL=1), or MCLK (SSEL=2 or SSEL=3). The clock source can be divided by one, two, four, or eight. The timer can be fully controlled (in word mode) since it can be halted, read, and written. It can be stopped or run continuously. It can count up or count up/down using one compare block to determine the period. The five capture/compare blocks are configured by the application software to run in either capture or compare mode.

The capture mode is primarily used to measure external or internal events with any combination of positive, negative, or both edges of the clock. The clock can also be stopped in capture mode by software. One external event (CCISx=0) per capture block can be selected. If CCISx=1, the ACLK is the capture signal; and if CCISx=2 or CCISx=3, software capture is chosen.

The compare mode is primarily used to generate timing for the software or application hardware or to generate pulse-width modulated output signals for various purposes like D/A conversion functions or motor control. An individual output module, which can run independently of the compare function or is triggered in several ways, is assigned to each of the five capture/compare registers.

Two interrupt vectors are used by the Timer\_A module. One individual vector is assigned to capture/compare block CCR0 and one common interrupt vector is assigned to the timer and the other four capture/compare blocks. The five interrupt events using the common vector are identified by an individual interrupt vector word. The interrupt vector word is used to add an offset to the program counter to continue the interrupt handler software at the correct location. This simplifies the interrupt handler and gives each interrupt event the same interrupt handler overhead of 5 cycles.

# MSP430C33x, MSP430P337A MIXED SIGNAL MICROCONTROLLERS

SLAS227A – OCTOBER 1999 – REVISED JUNE 2000

## Timer\_A (continued)

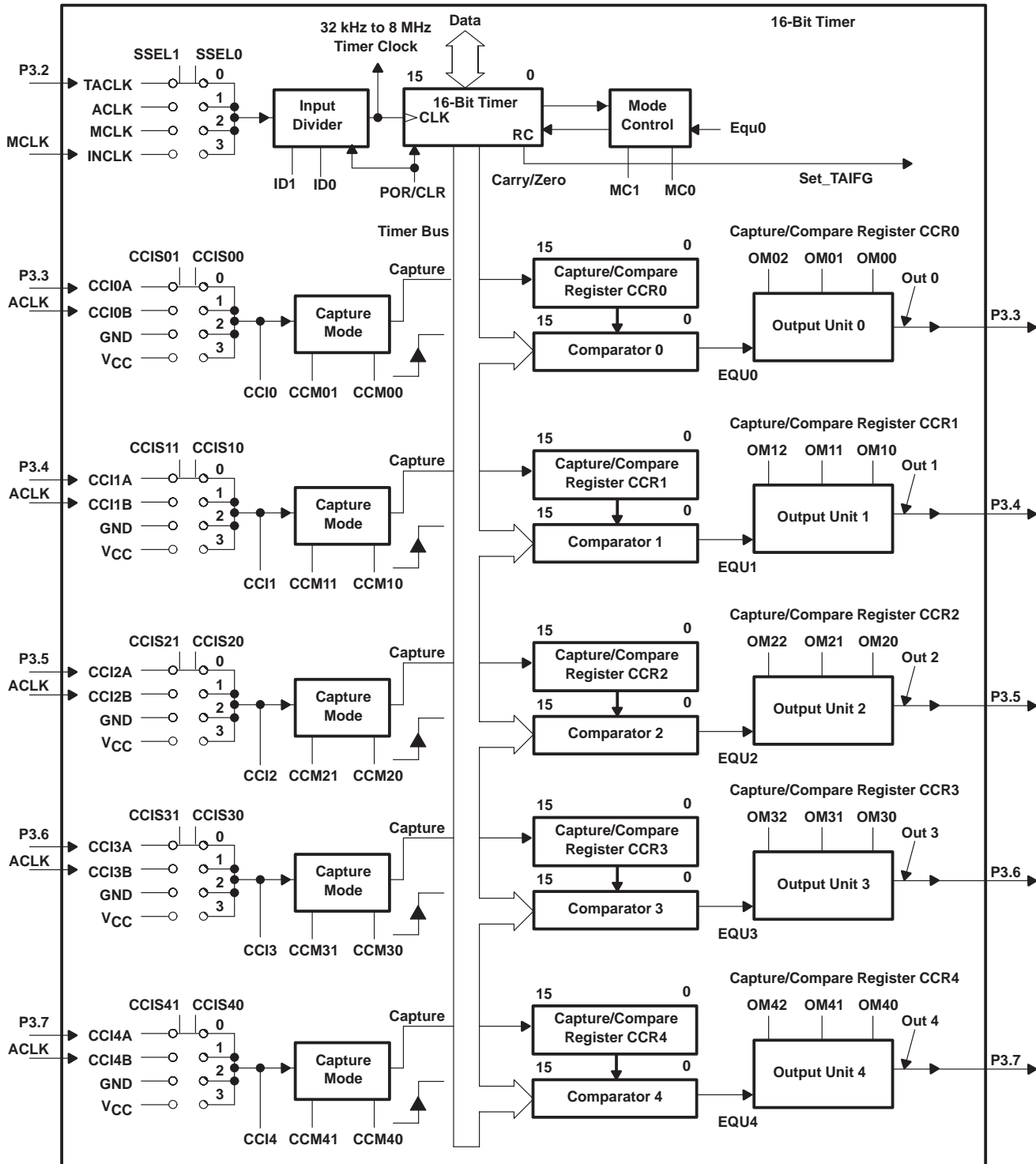

Figure 1. Timer\_A, MSP430x337 Configuration



## 8-Bit Timer/Counter

The 8-bit interval timer supports three major functions for applications:

- Serial communication or data exchange
- Plus counting or plus accumulation
- Timer

The 8-Bit Timer/Counter peripheral includes the following major blocks: an 8-bit up-counter with preload register, an 8-bit control register, an input clock selector, an edge detection (e.g. start bit detection for asynchronous protocols), and an input and output data latch, triggered by the carry-out-signal from the 8-Bit Timer/Counter.

The 8-Bit Timer/Counter counts up with an input clock, which is selected by two control bits from the control register. The four possible clock sources are MCLK, ACLK, the external signal from terminal P0.1, and the signal from the logical AND of MCLK and terminal P0.1.

Two counter inputs (load, enable) control the counter operation. The load input controls load operations. A write-access to the counter results in loading the content of the preload register into the counter. The software writes or reads the preload register with all instructions. The preload register acts as a buffer and can be written immediately after the load of the counter is completed. The enable input enables the count operation. When the enable signal is set to high, the counter will count-up each time a positive clock edge is applied to the clock input of the counter.

# MSP430C33x, MSP430P337A MIXED SIGNAL MICROCONTROLLERS

SLAS227A – OCTOBER 1999 – REVISED JUNE 2000

## peripheral file map

PERIPHERALS WITH BYTE ACCESS						
UART	Transmit buffer, UTXBUF	077h	Port P3	Port P3 selection, P3SEL	01Bh	
	Receive buffer, URXBUF	076h		Port P3 direction, P3DIR	01Ah	
	Baud rate, UBR1	075h		Port P3 output, P3OUT	019h	
	Baud rate, UBR0	074h		Port P3 input, P3IN	018h	
	Modulation control, UMCTL	073h		Port P0	Port P0 interrupt enable, P0IE	015h
	Receive control, URCTL	072h			Port P0 interrupt edge select, P0IES	014h
	Transmit control, UTCTL	071h			Port P0 interrupt flag, P0IFG	013h
	UART control, UCTL	070h			Port P0 direction, P0DIR	012h
EPROM	EPROM control, EPCTL	054h	Port P0 output, P0OUT	011h		
Crystal Buffer	Crystal buffer control, CBCTL	053h	Port P0 input, P0IN	010h		
System clock	SCG frequency control, SCFQCTL	052h	Special Function	SFR interrupt flag2, IFG2	003h	
	SCG frequency integrator, SCFI1	051h		SFR interrupt flag1, IFG1	002h	
	SCG frequency integrator, SCFI0	050h		SFR interrupt enable2, IE2	001h	
SFR interrupt enable1, IE1	000h					
Timer/Port	Timer/Port enable, TPE	04Fh	PERIPHERALS WITH WORD ACCESS			
	Timer/Port data, TPD	04Eh	Multiply	Sum extend, SumExt	013Eh	
	Timer/Port counter2, TPCNT2	04Dh		Result high word, ResHi	013Ch	
	Timer/Port counter1, TPCNT1	04Ch		Result low word, ResLo	013Ah	
	Timer/Port control, TPCTL	04Bh		Second operand, OP2	0138h	
Basic Timer1	Basic timer counter2, BTCNT2	047h		Multiply+accumulate/operand1, MACS	0136h	
	Basic timer counter1, BTCNT1	046h		Multiply+accumulate/operand1, MAC	0134h	
	Basic timer control, BTCTL	040h		Multiply signed/operand1, MPYS	0132h	
8-bit T/C	8-Bit Timer/Counter data, TCDAT	044h	Multiply unsigned/operand1, MPY	0130h		
	8-Bit Timer/Counter preload, TCPLD	043h	Watchdog	Watchdog Timer control, WDTCTL	0120h	
	8-Bit Timer/Counter control, TCCTL	042h		Timer_A	Timer_A interrupt vector, TAIV	012Eh
LCD	LCD memory 15, LCDM15	03Fh	Timer_A control, TACTL		0160h	
	:		Cap/Com control, CCTL0		0162h	
	LCD memory 1, LCDM1	031h	Cap/Com control, CCTL1		0164h	
	LCD control & mode, LCDCTL	030h	Cap/Com control, CCTL2		0166h	
Port P2	Port P2 selection, P2SEL	02Eh	Cap/Com control, CCTL3		0168h	
	Port P2 interrupt enable, P2IE	02Dh	Cap/Com control, CCTL4		016Ah	
	Port P2 interrupt edge select, P2IES	02Ch	Reserved		016Ch	
	Port P2 interrupt flag, P2IFG	02Bh	Reserved		016Eh	
	Port P2 direction, P2DIR	02Ah	Timer_A register, TAR		0170h	
	Port P2 output, P2OUT	029h	Cap/Com register, CCR0	0172h		
	Port P2 input, P2IN	028h	Cap/Com register, CCR1	0174h		
Port P1	Port P1 selection, P1SEL	026h	Cap/Com register, CCR2	0176h		
	Port P1 interrupt enable, P1IE	025h	Cap/Com register, CCR3	0178h		
	Port P1 interrupt edge select, P1IES	024h	Cap/Com register, CCR4	017Ah		
	Port P1 interrupt flag, P1IFG	023h	Reserved	017Ch		
	Port P1 direction, P1DIR	022h	Reserved	017Eh		
	Port P1 output, P1OUT	021h				
	Port P1 input, P1IN	020h				
Port P4	Port P4 selection, P4SEL	01Fh				
	Port P4 direction, P4DIR	01Eh				
	Port P4 output, P4OUT	01Dh				
	Port P4 input, P4IN	01Ch				



**absolute maximum ratings†**

Supply voltage range, between: $V_{CC}$ terminals .....	-0.3 V to 0.3 V
$V_{SS}$ terminals .....	-0.3 V to 0.3 V
Input voltage range to any $V_{SS}$ terminal: $V_{CC1}$ .....	-0.3 V to 6 V
$V_{CC2}$ .....	-0.3 V to 6 V
Input voltage range to any terminal (referenced to $V_{SS}$ ) .....	-0.3 V to $V_{CC} + 0.3$ V
Diode current at any device terminal .....	$\pm 2$ mA
Storage temperature range, $T_{stg}$ : Unprogrammed device .....	-55°C to 150°C
Programmed device .....	-40°C to 85°C

† Stresses beyond those listed under “absolute maximum ratings” may cause permanent damage to the device. These are stress ratings only, and functional operation of the device at these or any other conditions beyond those indicated under “recommended operating conditions” is not implied. Exposure to absolute-maximum-rated conditions for extended periods may affect device reliability.

NOTE: All voltages referenced to  $V_{SS}$ .

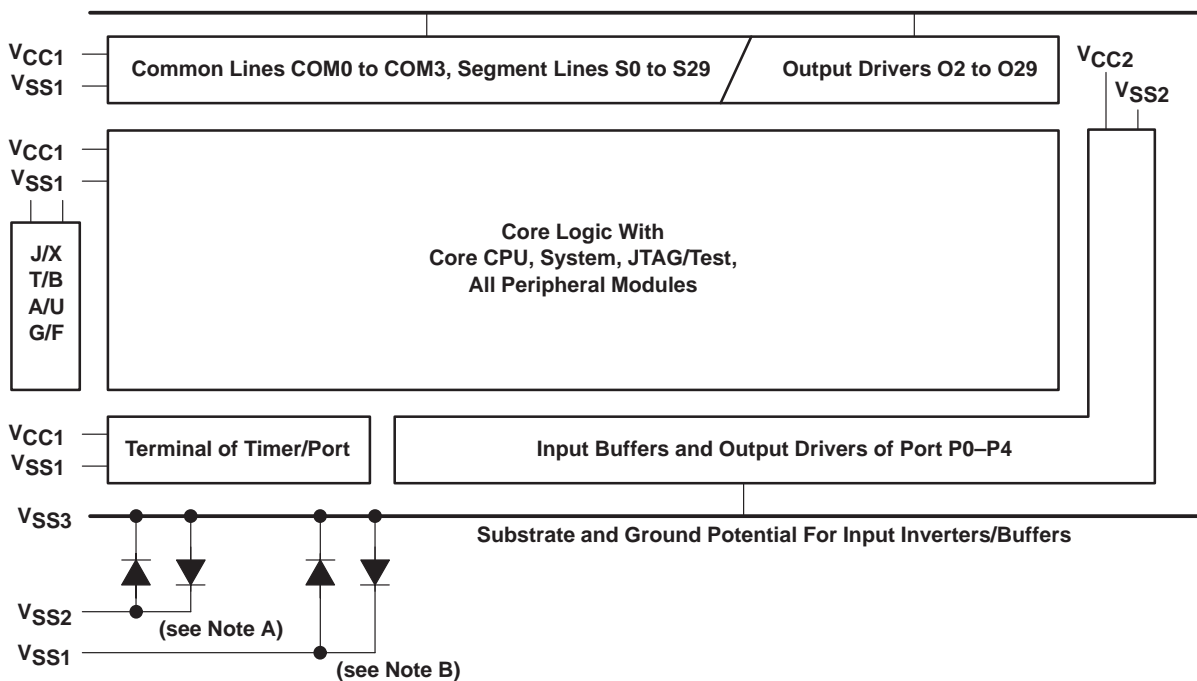

- NOTES: A. Ground potential for all port output drivers and input terminals, excluding first inverter/buffer  
 B. Ground potential for entire device core logic and peripheral modules

**Figure 2. Supply Voltage Interconnection**

# MSP430C33x, MSP430P337A MIXED SIGNAL MICROCONTROLLERS

SLAS227A – OCTOBER 1999 – REVISED JUNE 2000

## recommended operating conditions

		MIN	NOM	MAX	UNIT
Supply voltage, $V_{CC}$ , (MSP430C33x)		2.5		5.5	V
Supply voltage, $V_{CC}$ , (MSP430E/P33xA)		2.5		5.5	V
Supply voltage, during programming, $V_{CC}(V_{CC1} = V_{CC2})$ OTP/EPROM	MSP430P337A, PMS430E337A	4.5	5	5.5	V
Supply voltage, $V_{SS}$			0		V
Operating free-air temperature range $T_A$	MSP430C33x, MSP430P33xA	-40		85	°C
	PMS430E33xA		25		
XTAL frequency $f_{XTAL}$ (signal ACLK)			32768		HZ
Processor frequency (signal MCLK), $f_{system}$	$V_{CC} = 3$ V		DC	1.65	MHz
	$V_{CC} = 5$ V		DC	3.8	MHz
Low-level input voltage, $V_{IL}$ † (excluding $X_{in}$ , $X_{out}$ )	$V_{CC} = 3$ V/5 V		$V_{SS}$	$V_{SS}+0.8$	V
High-level input voltage, $V_{IH}$ † (excluding $X_{in}$ , $X_{out}$ )		$0.7 \times V_{CC}$	$V_{CC}$		
Low-level input voltage, $V_{IL}(X_{in}, X_{out})$		$V_{SS}$	$0.2 \times V_{CC1}$	V	
High-level input voltage, $V_{IH}(X_{in}, X_{out})$		$0.8 \times V_{CC1}$	$V_{CC1}$		

† A serial resistor of 1 kΩ to the RST/NMI pin is recommended to enhance latch-up immunity.

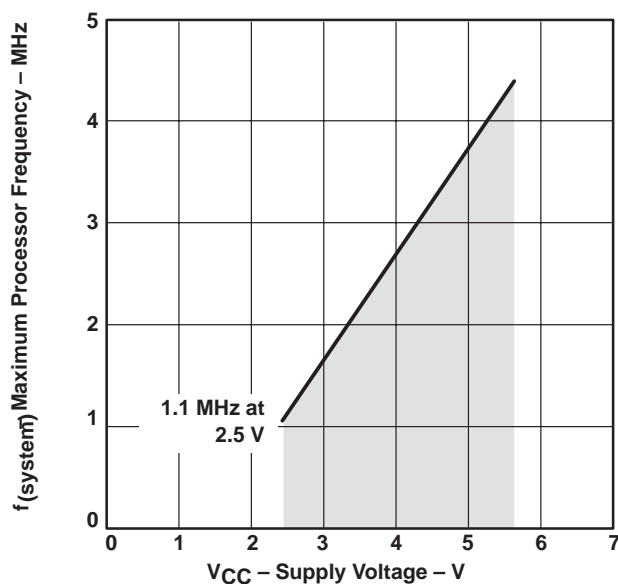

Figure 3. Processor Frequency vs Supply Voltage

electrical characteristics over recommended operating free-air temperature range (unless otherwise noted)

supply current (into  $V_{CC}$ ) excluding external current ( $f_{\text{system}} = 1 \text{ MHz}$ ) (see Note 6)

PARAMETER		TEST CONDITIONS	MIN	NOM	MAX	UNIT	
$I_{(AM)}$	Active mode	C336/7 $T_A = -40^\circ\text{C} + 85^\circ\text{C}, V_{CC} = 3 \text{ V}$	400	500	$\mu\text{A}$		
			800	900			
		P337A $T_A = -40^\circ\text{C} + 85^\circ\text{C}, V_{CC} = 3 \text{ V}$	570	700			
			1170	1250			
$I_{(CPUOff)}$	Low power mode, (LPM0,1)	C336/7 $T_A = -40^\circ\text{C} + 85^\circ\text{C}, V_{CC} = 3 \text{ V}$	50	70	$\mu\text{A}$		
			100	130			
		P337A $T_A = -40^\circ\text{C} + 85^\circ\text{C}, V_{CC} = 3 \text{ V}$	50	70			
			100	130			
$I_{(LPM2)}$	Low power mode, (LPM2)	$T_A = -40^\circ\text{C} + 85^\circ\text{C}, V_{CC} = 3 \text{ V}$	7	12	$\mu\text{A}$		
		$T_A = -40^\circ\text{C} + 85^\circ\text{C}, V_{CC} = 5 \text{ V}$	18	25			
$I_{(LPM3)}$	Low power mode, (LPM3)	$T_A = -40^\circ\text{C}$	$V_{CC} = 3 \text{ V}$	2.0	3.5	$\mu\text{A}$	
				$T_A = 25^\circ\text{C}$	2.0		3.5
				$T_A = 85^\circ\text{C}$	1.6		3.5
		$T_A = -40^\circ\text{C}$	$V_{CC} = 5 \text{ V}$	5.2	10		
				$T_A = 25^\circ\text{C}$	4.2		10
				$T_A = 85^\circ\text{C}$	4.0		10
$I_{(LPM4)}$	Low power mode, (LPM4)	$T_A = -40^\circ\text{C}$	$V_{CC} = 3 \text{ V}/5 \text{ V}$	0.1	0.8	$\mu\text{A}$	
				$T_A = 25^\circ\text{C}$	0.1		0.8
				$T_A = 85^\circ\text{C}$	0.4		1.5

NOTE 6: All inputs are tied to 0 V or  $V_{CC2}$ . Outputs do not source or sink any current. The current consumption in LPM2 and LPM3 are measured with active Basic Timer1 module (ACLK selected), LCD Module ( $f_{LCD} = 1024 \text{ Hz}$ , 4MUX) and USART module (UART, ACLK, 2400 Baud selected)

Current consumption of active mode versus system frequency,

$$I_{AM} = I_{AM[1\text{MHz}]} \times f_{\text{system}}[\text{MHz}]$$

Current consumption of active mode versus supply voltage,

$$I_{AM} = I_{AM[3\text{V}]} + 200 \mu\text{A/V} \times (V_{CC} - 3)$$

**schmitt-trigger inputs Port 0 to P4: P0.x to P4.x, Timer/Port: CIN, TP0.5**

PARAMETER	TEST CONDITIONS	MIN	NOM	MAX	UNIT
$V_{IT+}$ Positive-going input threshold voltage	$V_{CC} = 3 \text{ V}$	1.2		2.1	V
	$V_{CC} = 5 \text{ V}$	2.3		3.4	
$V_{IT-}$ Negative-going input threshold voltage	$V_{CC} = 3 \text{ V}$	0.7		1.5	V
	$V_{CC} = 5 \text{ V}$	1.4		2.3	
$V_{\text{hys}}$ Input hysteresis ( $V_{IT+} - V_{IT-}$ )	$V_{CC} = 3 \text{ V}$	0.3		1	V
	$V_{CC} = 5 \text{ V}$	0.6		1.4	

# MSP430C33x, MSP430P337A MIXED SIGNAL MICROCONTROLLERS

SLAS227A – OCTOBER 1999 – REVISED JUNE 2000

**electrical characteristics over recommended operating free-air temperature range (unless otherwise noted) (continued)**

**outputs Port 0 to P4: P0.x to P4.x, Timer/Port: TP0.0 to TP0.5, LCD: S2/O2 to S29/O29, XBUF: XBUF, JTAG:TDO**

PARAMETER		TEST CONDITIONS		MIN	NOM	MAX	UNIT
V <sub>OH</sub>	High-level output voltage	I <sub>OH</sub> = -1.2 mA, See Note 7	V <sub>CC</sub> = 3 V	V <sub>CC</sub> -0.4		V <sub>CC</sub>	V
		I <sub>OH</sub> = -3.5 mA, See Note 8		V <sub>CC</sub> -1.0		V <sub>CC</sub>	
		I <sub>OH</sub> = -1.5 mA, See Note 7	V <sub>CC</sub> = 5 V	V <sub>CC</sub> -0.4		V <sub>CC</sub>	
		I <sub>OH</sub> = -4.5 mA, See Note 8		V <sub>CC</sub> -1.0		V <sub>CC</sub>	
V <sub>OL</sub>	Low-level output voltage	I <sub>OL</sub> = 1.2 mA, See Note 7	V <sub>CC</sub> = 3 V	V <sub>SS</sub>		V <sub>SS</sub> +0.4	V
		I <sub>OL</sub> = 3.5 mA, See Note 8		V <sub>SS</sub>		V <sub>SS</sub> +1	
		I <sub>OL</sub> = 1.5 mA, See Note 7	V <sub>CC</sub> = 5 V	V <sub>SS</sub>		V <sub>SS</sub> +0.4	
		I <sub>OL</sub> = 4.5 mA, See Note 8		V <sub>SS</sub>		V <sub>SS</sub> +1	

NOTES: 7. The maximum total current for all outputs combined should not exceed ±9.6 mA to hold the maximum voltage drop specified.

8. The maximum total current for all outputs combined should not exceed ±28 mA to hold the maximum voltage drop specified.

## leakage current (see Note 9)

PARAMETER		TEST CONDITIONS		MIN	NOM	MAX	UNIT
I <sub>lkg</sub> (TP)	High-impedance leakage current, Timer/Port	Timer/Port: V <sub>TP0.x</sub> , V <sub>CC</sub> = 3 V/5 V,	C <sub>IN</sub> = V <sub>SS</sub> , V <sub>CC</sub> , (see Note 10)			± 50	nA
I <sub>lkg</sub> (S27)	High-impedance leakage current, S27	V <sub>S27</sub> = V <sub>SS</sub> to V <sub>CC</sub> ,	V <sub>CC</sub> = 3 V/5 V			± 50	nA
I <sub>lkg</sub> (P0x)	Leakage current, port 0	Port P0: P0.x, 0 ≤ x ≤ 7, (see Note 11)	V <sub>CC</sub> = 3 V/5 V,			± 50	nA

NOTES: 9. The leakage current is measured with V<sub>SS</sub> or V<sub>CC</sub> applied to the corresponding pins(s) – unless otherwise noted.

10. All Timer/Port pins (TP0.0 to TP0.5) are Hi-Z. Pins C<sub>IN</sub> and TP0.0 to TP0.5 are connected together during leakage current measurement. In the leakage measurement mode, the input C<sub>IN</sub> is included. The input voltage is V<sub>SS</sub> or V<sub>CC</sub>.

11. The leakages of the digital port terminals are measured individually. The port terminal must be selected for input and there must be no optional pullup or pulldown resistor.

## optional resistors (see Note 12)

PARAMETER		TEST CONDITIONS	MIN	NOM	MAX	UNIT
R <sub>(opt1)</sub>	Resistors, individually programmable with ROM code, all port pins, values applicable for pulldown and pullup	V <sub>CC</sub> = 3 V/5 V	1.4	4.1	6.8	kΩ
R <sub>(opt2)</sub>		V <sub>CC</sub> = 3 V/5 V	2.1	6.2	11	kΩ
R <sub>(opt3)</sub>		V <sub>CC</sub> = 3 V/5 V	4.2	12	20	kΩ
R <sub>(opt4)</sub>		V <sub>CC</sub> = 3 V/5 V	6.6	19	32	kΩ
R <sub>(opt5)</sub>		V <sub>CC</sub> = 3 V/5 V	12	37	62	kΩ
R <sub>(opt6)</sub>		V <sub>CC</sub> = 3 V/5 V	26	75	124	kΩ
R <sub>(opt7)</sub>		V <sub>CC</sub> = 3 V/5 V	39	112	185	kΩ
R <sub>(opt8)</sub>		V <sub>CC</sub> = 3 V/5 V	65	187	309	kΩ
R <sub>(opt9)</sub>		V <sub>CC</sub> = 3 V/5 V	91	261	431	kΩ
R <sub>(opt10)</sub>		V <sub>CC</sub> = 3 V/5 V	117	337	557	kΩ

NOTE 12: Optional resistors R<sub>(optx)</sub> for pulldown or pullup are not programmed in standard OTP/EPROM devices P/E 337.



electrical characteristics over recommended operating free-air temperature range (unless otherwise noted) (continued)

inputs and outputs

	PARAMETER	TEST CONDITIONS	VCC	MIN	NOM	MAX	UNIT
t <sub>(int)</sub>	External interrupt timing	Port P0, P1 to P2: External trigger signal for the interrupt flag (see Notes 13 and 14)	3 V/5 V	1.5			cycle
t <sub>(cap)</sub>	Timer_A, capture timing	TA0-TA4 External capture signal (see Note 15)	3 V/5 V	250			ns
f <sub>(IN)</sub>	Input frequency	P0.1, CIN, TP 0.5, UCLK, SIMO, SOMI, TACLK, TA0-TA4	3 V/5 V	DC		f <sub>(system)</sub>	MHz
t <sub>(H)</sub> or t <sub>(L)</sub>			3 V	300		f <sub>(system)</sub>	ns
t <sub>(H)</sub> or t <sub>(L)</sub>			5 V	300		f <sub>(system)</sub>	ns
f <sub>(XBUF)</sub>	Output frequency	XBUF, C <sub>L</sub> = 20 pF	3 V/5 V			f <sub>(system)</sub>	MHz
f <sub>(TAX)</sub>		TA0-4, C <sub>L</sub> = 20 pF	3 V/5 V	DC		f <sub>(system)/2</sub>	
f <sub>(UCLK)</sub>		UCLK, C <sub>L</sub> = 20 pF	3 V/5 V	DC		f <sub>(system)</sub>	
t <sub>(Xdc)</sub>	Duty cycle of output	XBUF, C <sub>L</sub> = 20 pF f <sub>(MCLK)</sub> = 1.1 MHz f <sub>(XBUF)</sub> = f <sub>(ACLK)</sub> f <sub>(XBUF)</sub> = f <sub>(ACLK/n)</sub>	3 V/5 V 3 V/5 V 3 V/5 V	40% 35%		60% 65%	
Δt <sub>(TA)</sub>		TA0..4, C <sub>L</sub> = 20 pF t <sub>(TAH)</sub> = t <sub>(TAL)</sub>	3 V/5 V		0	±100	ns
Δt <sub>(UC)</sub>		UCLK, C <sub>(L)</sub> = 15pF t <sub>(UCH)</sub> = t <sub>(UCL)</sub>	3 V/5 V		0	±100	ns
t <sub>(τ)</sub>	USART: Deglitch time	See Note16	3 V 5 V	0.6 0.3		2.6 1.4	μs

- NOTES: 13. The external signal sets the interrupt flag every time t<sub>(int)</sub> is met. It may be set even with trigger signals shorter than t<sub>(int)</sub>. The conditions to set the flag must be met independently from this timing constraint. T<sub>(int)</sub> is defined in MCLK cycles.
14. The external interrupt signal cannot exceed the maximum input frequency (f<sub>(in)</sub>)
15. The external capture signal triggers the capture event every time t<sub>(cap)</sub> is met. It may be triggered even with capture signals shorter than t<sub>(cap)</sub>. The conditions to set the flag must be met independently from this timing constraint.
16. The signal applied to the USART receive signal/terminal (URXD) should meet the timing requirements of t<sub>(τ)</sub> to ensure that the URXS flip-flop is set. The URXS flip-flop is set with negative pulses meeting the minimum timing condition of t<sub>(τ)</sub>. The operating conditions to set the flag must be met independently from this timing constraint. The deglitch circuitry is active only on negative transitions on the URXD line.

LCD

PARAMETER	TEST CONDITIONS	MIN	NOM	MAX	UNIT
V <sub>(33)</sub>	Voltage at R33 Voltage at R23 Voltage at R13 Voltage at R03 V <sub>CC</sub> = 3 V/5 V	2.5		V <sub>CC</sub> +0.2	V
V <sub>(23)</sub>		$(V_{33}-V_{03}) \times 2/3 + V_{03}$			
V <sub>(13)</sub>		$(V_{33}-V_{03}) \times 1/3 + V_{03}$			
V <sub>(03)</sub>		V <sub>(33)</sub> - 2.5		V <sub>CC</sub> +0.2	
V <sub>O</sub> (HLCD)	Output 1 I <sub>(HLCD)</sub> <= 10 nA	V <sub>(R33)</sub> - 0.125		V <sub>CC</sub>	V
V <sub>O</sub> (LLCD)	Output 0 I <sub>(LLCD)</sub> <= 10 nA	V <sub>SS</sub>		V <sub>SS</sub> + 0.125	V
I <sub>(R03)</sub>	Input leakage R03 = V <sub>SS</sub> R13 = V <sub>CC</sub> /3 R23 = 2 × V <sub>CC</sub> /3 V <sub>CC</sub> = 3 V/5 V			±20	nA
I <sub>(R13)</sub>				±20	
I <sub>(R23)</sub>				±20	
V <sub>(Sxx0)</sub>	Segment line voltage I <sub>(Sxx)</sub> = - 3 μA, V <sub>CC</sub> = 3 V/5 V	V <sub>(03)</sub>		V <sub>(03)</sub> - 0.1	V
V <sub>(Sxx1)</sub>		V <sub>(13)</sub>		V <sub>(13)</sub> - 0.1	
V <sub>(Sxx2)</sub>		V <sub>(23)</sub>		V <sub>(23)</sub> - 0.1	
V <sub>(Sxx3)</sub>		V <sub>(33)</sub>		V <sub>(33)</sub> + 0.1	

# MSP430C33x, MSP430P337A MIXED SIGNAL MICROCONTROLLERS

SLAS227A – OCTOBER 1999 – REVISED JUNE 2000

electrical characteristics over recommended operating free-air temperature range (unless otherwise noted) (continued)

## PUC/POR

PARAMETER		TEST CONDITIONS		MIN	NOM	MAX	UNIT
$t_{(POR)}$ delay	POR	$V_{CC} = 3\text{ V}/5\text{ V}$		150	250		$\mu\text{s}$
$V_{(POR)}$			$T_A = -40^\circ\text{C}$	1.5	2.4		V
			$T_A = 25^\circ\text{C}$	1.2	2.1		V
			$T_A = 85^\circ\text{C}$	0.9	1.8		V
$V_{(min)}$			0	0.4		V	
$t_{(reset)}$	PUC/POR	Reset is accepted internally		2			$\mu\text{s}$

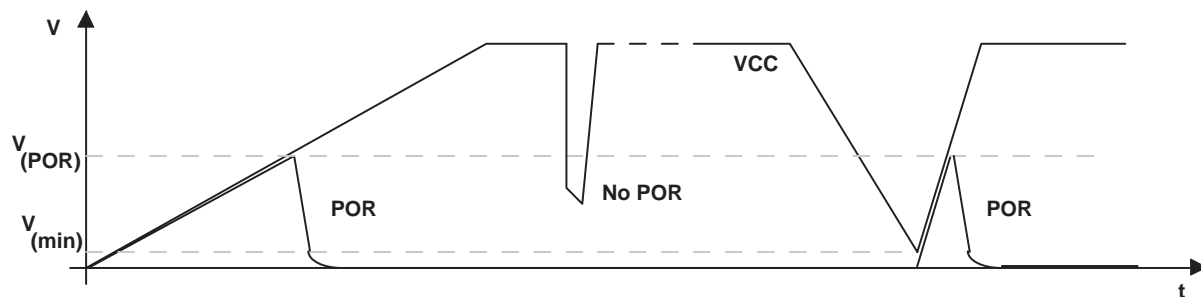

Figure 4. Power-On Reset (POR) vs Supply Voltage

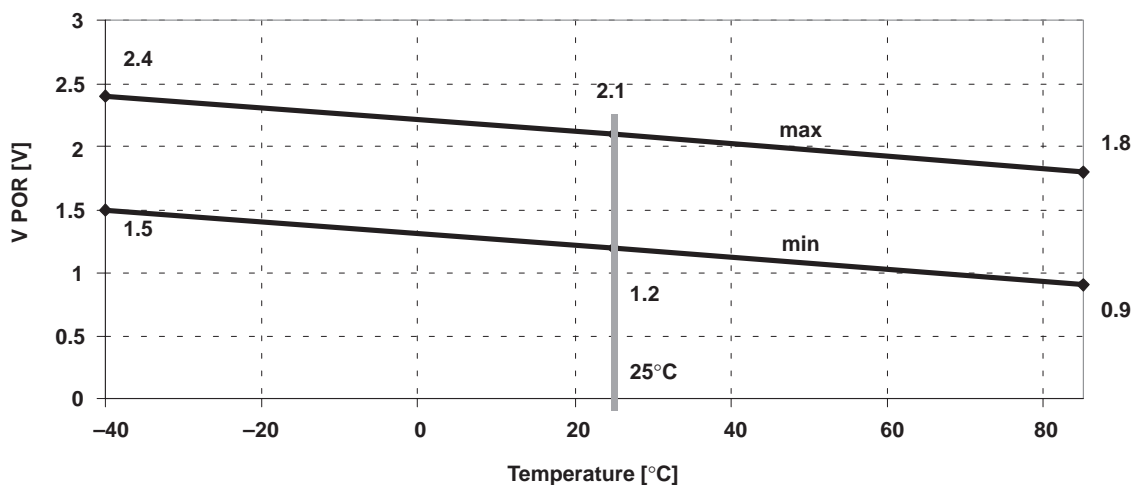

Figure 5.  $V_{(POR)}$  vs Temperature

## crystal oscillator: $X_{in}$ , $X_{out}$

PARAMETER		TEST CONDITIONS	MIN	NOM	MAX	UNIT
$C_{(Xin)}$	Integrated capacitance at input	$V_{CC} = 3\text{ V}/5\text{ V}$		12		pF
$C_{(Xout)}$	Integrated capacitance at output			12		pF



electrical characteristics over recommended operating free-air temperature range (unless otherwise noted) (continued)

DCO

PARAMETER		TEST CONDITIONS	MIN	NOM	MAX	UNIT
$f_{(NOM)}$	DCO	$N_{(DCO)} = 1$ A0h $FN_4=FN_3=FN_2 = 0$		1		MHz
$f_{(NOM)}$	$f_{(DCO3)}$	$N_{(DCO)} = 00$ 0110 0000 $FN_4=FN_3=FN_2 = 0$	$V_{CC} = 3$ V	0.15	0.6	MHz
			$V_{CC} = 5$ V	0.18	0.62	
$f_{(NOM)}$	$f_{(DCO26)}$	$N_{(DCO)} = 11$ 0100 0000 $FN_4=FN_3=FN_2 = 0$	$V_{CC} = 3$ V	1.25	4.7	MHz
			$V_{CC} = 5$ V	1.45	5.5	
$2xf_{(NOM)}$	$f_{(DCO3)}$	$N_{(DCO)} = 00$ 0110 0000 $FN_4=FN_3=0, FN_2 = 1$	$V_{CC} = 3$ V	0.36	1.05	MHz
			$V_{CC} = 5$ V	0.39	1.2	
$2xf_{(NOM)}$	$f_{(DCO26)}$	$N_{(DCO)} = 11$ 0100 0000 $FN_4=FN_3=0, FN_2 = 1$	$V_{CC} = 3$ V	2.5	8.1	MHz
			$V_{CC} = 5$ V	3	9.9	
$3xf_{(NOM)}$	$f_{(DCO3)}$	$N_{(DCO)} = 00$ 0110 0000 $FN_4=0, FN_3=1, FN_2=X$	$V_{CC} = 3$ V	0.5	1.5	MHz
			$V_{CC} = 5$ V	0.6	1.8	
$3xf_{(NOM)}$	$f_{(DCO26)}$	$N_{(DCO)} = 11$ 0100 0000 $FN_4=0, FN_3=1, FN_2=X$	$V_{CC} = 3$ V	3.7	11	MHz
			$V_{CC} = 5$ V	4.5	13.8	
$4xf_{(NOM)}$	$f_{(DCO3)}$	$N_{(DCO)} = 00$ 0110 0000 $FN_4=1, FN_3 = FN_2=X$	$V_{CC} = 3$ V	0.7	1.85	MHz
			$V_{CC} = 5$ V	0.8	2.4	
$4xf_{(NOM)}$	$f_{(DCO26)}$	$N_{(DCO)} = 11$ 0100 0000 $FN_4=1, FN_3 = FN_2=X$	$V_{CC} = 3$ V	4.8	13.3	MHz
			$V_{CC} = 5$ V	6	17.7	
$N_{(DCO)}$		$f_{(MCLK)} = f_{(NOM)}$ $FN_4=FN_3=FN_2 = 0$	$V_{CC} = 3$ V/5 V	A0h	1A0h	340h
S		$f_{(NDCO)}+1 = S \times f_{(NDCO)}$	$V_{CC} = 3$ V/5 V	1.07	1.13	

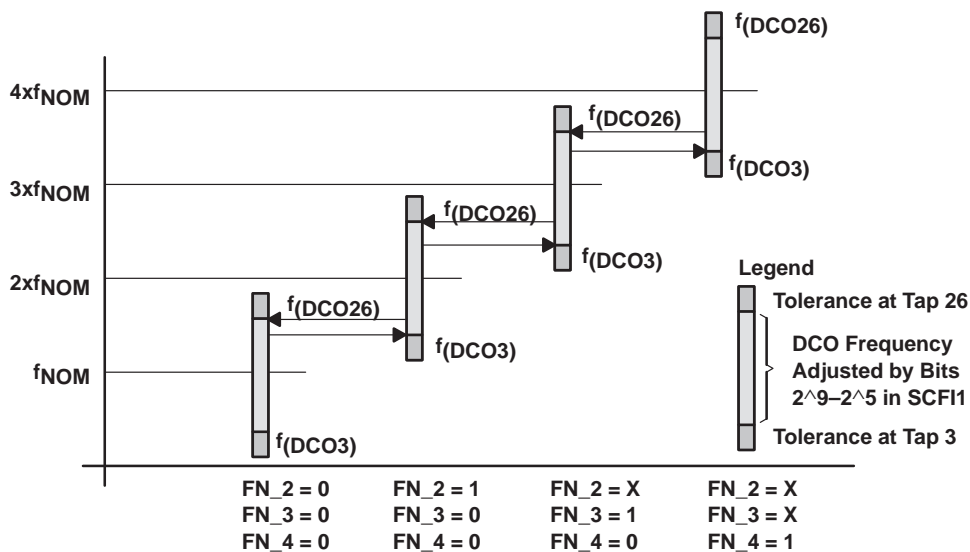

# MSP430C33x, MSP430P337A MIXED SIGNAL MICROCONTROLLERS

SLAS227A – OCTOBER 1999 – REVISED JUNE 2000

## electrical characteristics over recommended and operating free-air temperature range (unless otherwise noted) (continued)

### RAM

PARAMETER	TEST CONDITIONS	MIN	NOM	MAX	UNIT
V(RAMh)	CPU halted (see Note 17)	1.8			V

NOTE 17: This parameter defines the minimum supply voltage when the data in the program memory RAM remains unchanged. No program execution should happen during this supply voltage condition.

### Timer/Port comparator

PARAMETER	TEST CONDITIONS	MIN	NOM	MAX	UNIT
I <sub>(com)</sub>	Comparator (Timer/Port) CPON = 1	V <sub>CC</sub> = 3 V	175	350	μA
		V <sub>CC</sub> = 5 V		600	
V <sub>ref</sub> (COM)	Internal reference voltage at (-) terminal CPON = 1	V <sub>CC</sub> = 3 V/5 V	0.230 × V <sub>CC1</sub>	0.260 × V <sub>CC1</sub>	V
V <sub>hys</sub> (COM)	Input hysteresis (comparator) CPON = 1	V <sub>CC</sub> = 3 V	5	37	mV
		V <sub>CC</sub> = 5 V	10	42	mV

### JTAG, program memory

PARAMETER	TEST CONDITIONS	MIN	NOM	MAX	UNIT		
f(TCK)	JTAG/test TCK frequency	V <sub>CC</sub> = 3 V	DC	5	MHz		
		V <sub>CC</sub> = 5 V	DC	10			
R(test)	Pullup resistors on TMS, TCK, TDI (see Note 18)	V <sub>CC</sub> = 3 V/5 V	25	60	90	kΩ	
V(FB)	JTAG/fuse (see Note 19)	Fuse blow voltage, C versions (see Note 20)	V <sub>CC</sub> = 3 V/5 V	5.5	6		
I(FB)		Fuse blow voltage, E/P versions (see Note 20)	V <sub>CC</sub> = 3 V/5 V	11	12		
t(FB)	Supply current on TDI/VPP to blow fuse			100		mA	
t(FB)	Time to blow the fuse			1		ms	
V(PP)	EPROM(E) and OTP(P) versions only	Programming voltage, applied to TDI/VPP		12.0	12.5	13.0	V
I(PP)		Current from programming voltage source			70		mA
t(pps)		Programming time, single pulse		5			ms
t(ppf)		Programming time, fast algorithm			100		μs
P <sub>n</sub>		Number of pulses for successful programming		4	100		Pulse
		Data retention T <sub>J</sub> < 55°C		10			Year
t(erase)		EPROM(E) version only	Erase time wave length 2537 Å at 15 Ws/cm <sup>2</sup> (UV lamp of 12 mW/cm <sup>2</sup> )		30		
	Write/erase cycles		1000				

NOTES: 18. The TMS and TCK pullup resistors are implemented in all ROM(C), OTP(P) and EPROM(E) versions. The pullup resistor on TDI is implemented in C versions only.

19. Once the fuse is blown no further access to the MSP430 JTAG/test feature is possible.

20. The voltage supply to blow the fuse is applied to TDI/VPP pin during the fuse blowing procedure.



typical input/output schematics

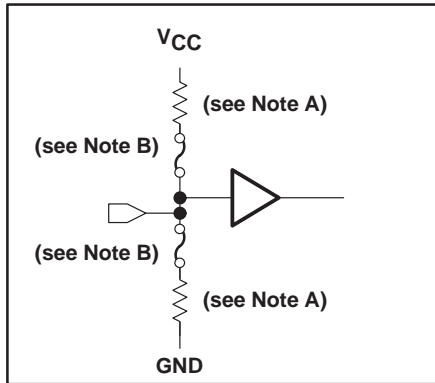

CMOS INPUT

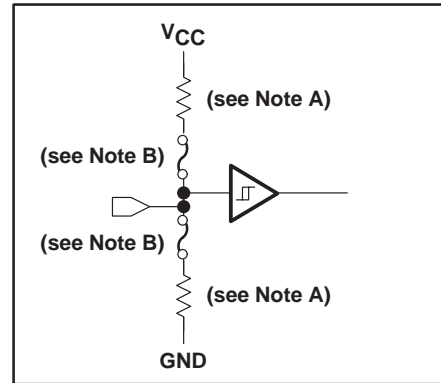

CMOS SCHMITT-TRIGGER INPUT

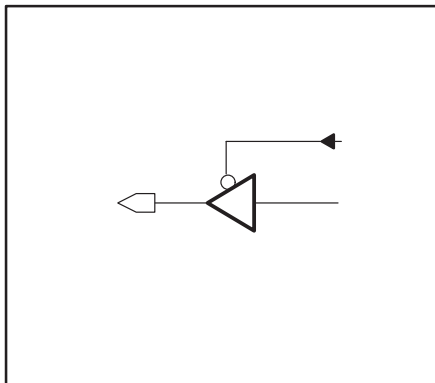

CMOS 3-STATE OUTPUT

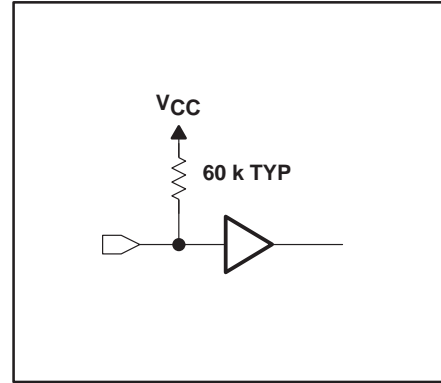

MSP430C336/337: TMS, TCK, TDI  
MSP430P/E337A: TMS, TCK

- NOTES: A. Optional selection of pullup or pulldown resistors available on ROM (masked) versions.  
B. Fuses for the optional pullup and pulldown resistors can only be programmed at the factory.

# MSP430C33x, MSP430P337A MIXED SIGNAL MICROCONTROLLERS

SLAS227A – OCTOBER 1999 – REVISED JUNE 2000

## typical input/output schematics (continued)

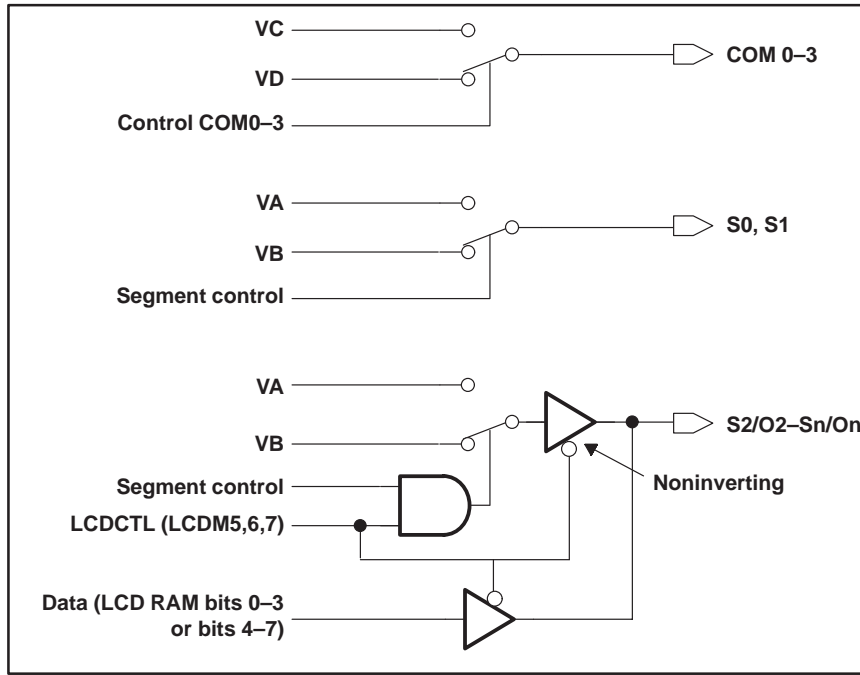

LCD OUTPUT (COM0-4, Sn, Sn/On)

NOTE A: The signals VA, VB, VC, and VD come from the LCD module analog voltage generator.

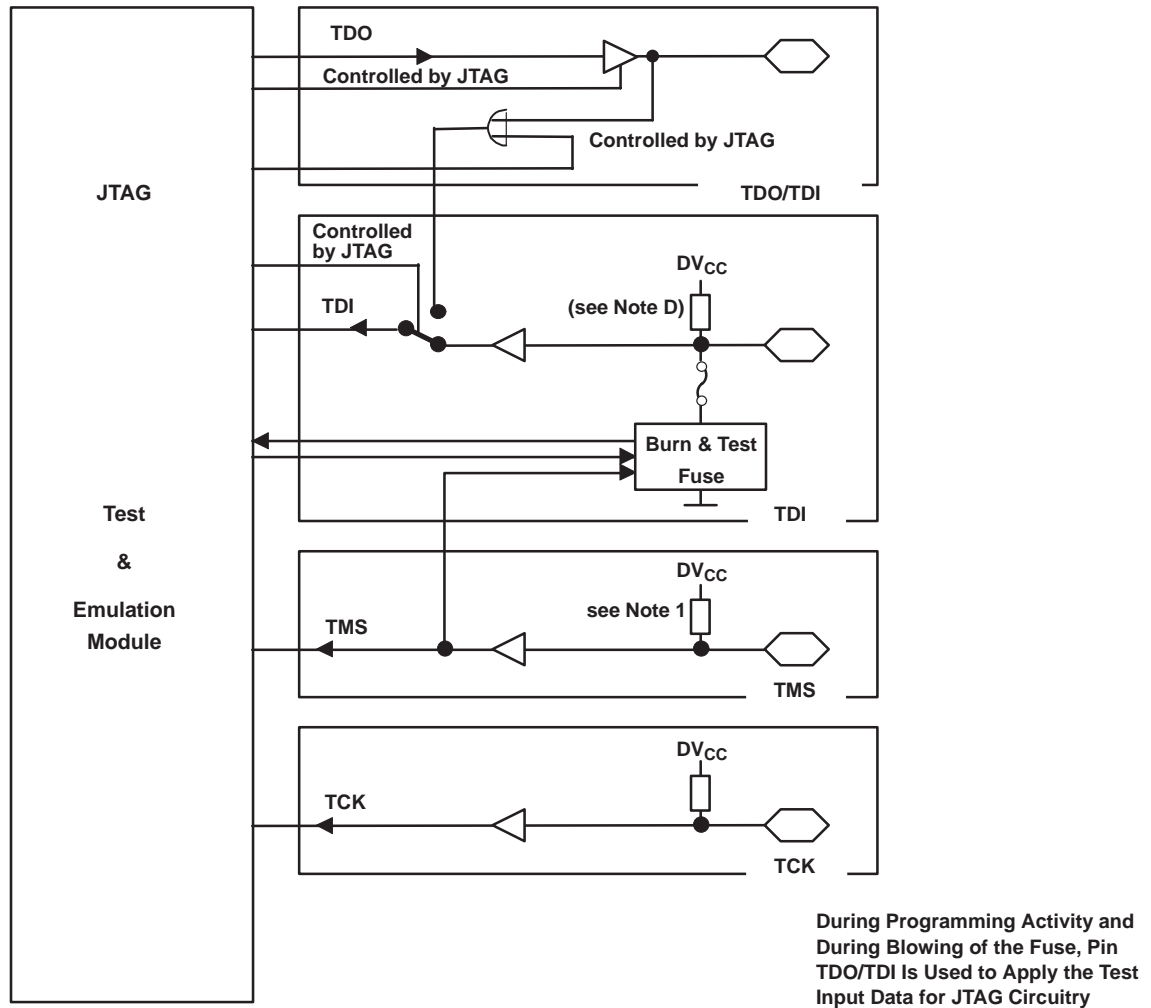

- NOTES: A. During programming activity and when blowing the JTAG enable fuse, the TDI/VPP terminal is used to apply the correct voltage source. The TDO/TDI terminal is used to apply the test input data for JTAG circuitry.
- B. The TDI/VPP terminal of the 'P337A and 'E337A does not have an internal pullup resistor. An external pulldown resistor is recommended to avoid a floating node, which could increase the current consumption of the device. *Remove the external pulldown resistors when switching from P/E337A to C337 devices. Otherwise system power consumption will increase.*
- C. The TDO/TDI terminal is in a high-impedance state after POR. The 'P337A and 'E337A need a pullup or a pulldown resistor to avoid floating a node, which could increase the current consumption of the device.
- D. The pullup resistor is only implemented in C-version

Figure 6. MSP430P/E337A: TDI/VPP, TDO/TDI

# MSP430C33x, MSP430P337A MIXED SIGNAL MICROCONTROLLERS

SLAS227A – OCTOBER 1999 – REVISED JUNE 2000

## typical input/output schematics (continued)

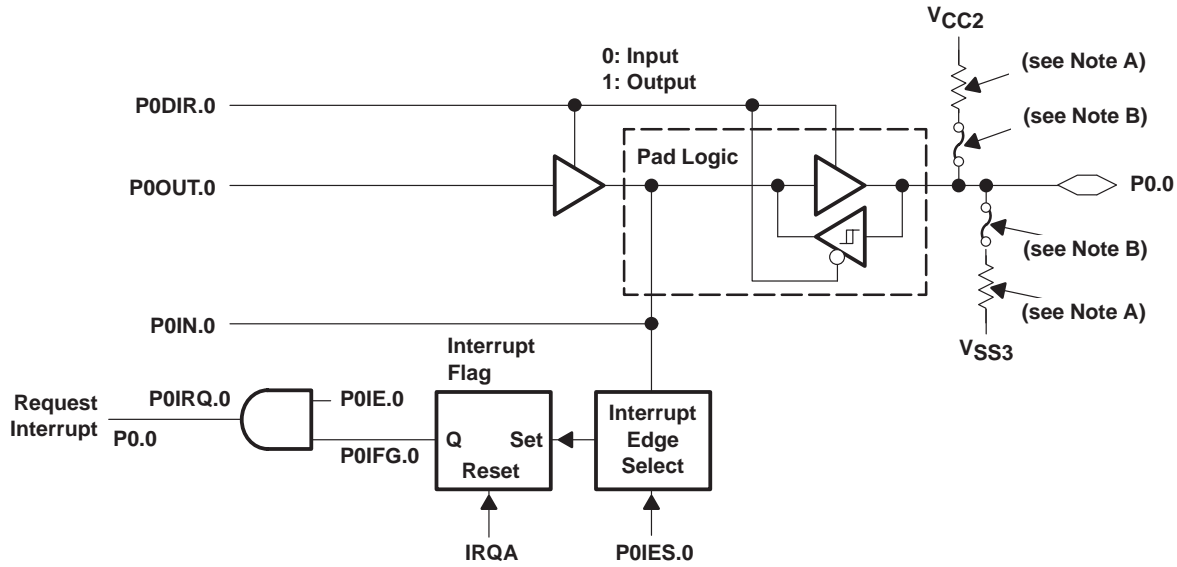

NOTES: A. Optional selection of pullup or pulldown resistors available on ROM (masked) versions.  
B. Fuses for the optional pullup and pulldown resistors can only be programmed at the factory.

Figure 7. Port P0, P0.0, Input/Output With Schmitt-Trigger

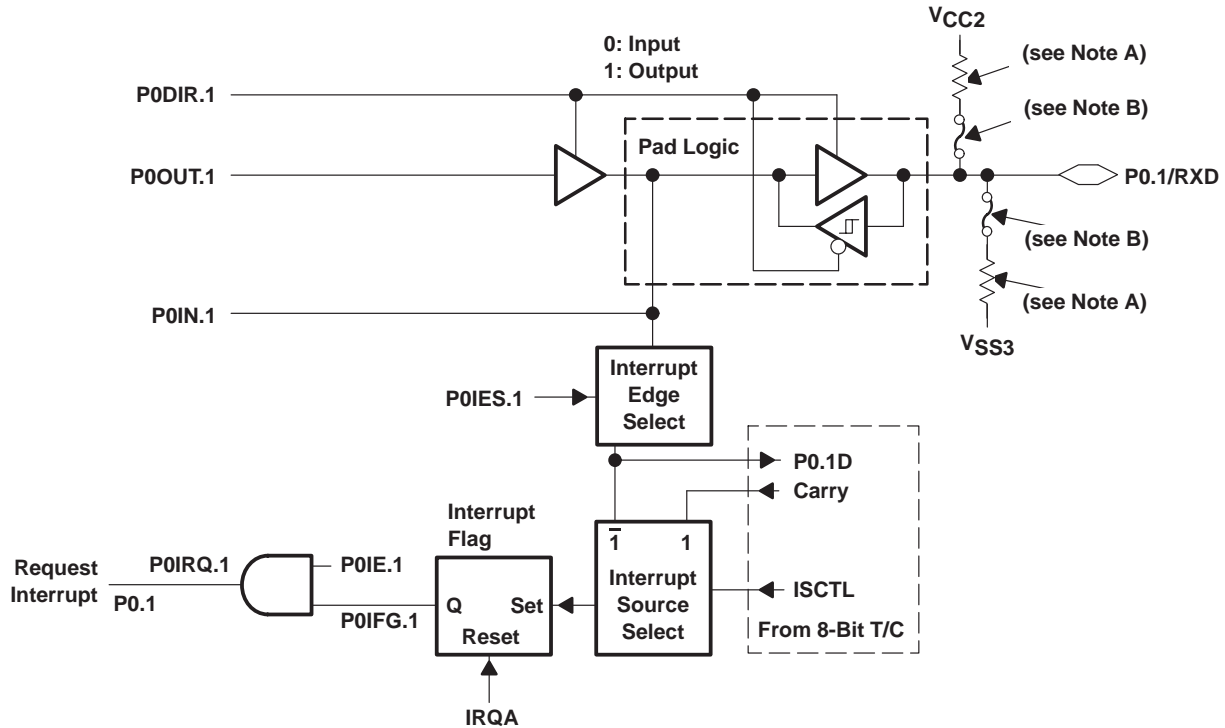

NOTES: A. Optional selection of pullup or pulldown resistors available on ROM (masked) versions.  
B. Fuses for the optional pullup and pulldown resistors can only be programmed at the factory.

Figure 8. Port P0, P0.1, Input/Output With Schmitt-Trigger

typical input/output schematics (continued)

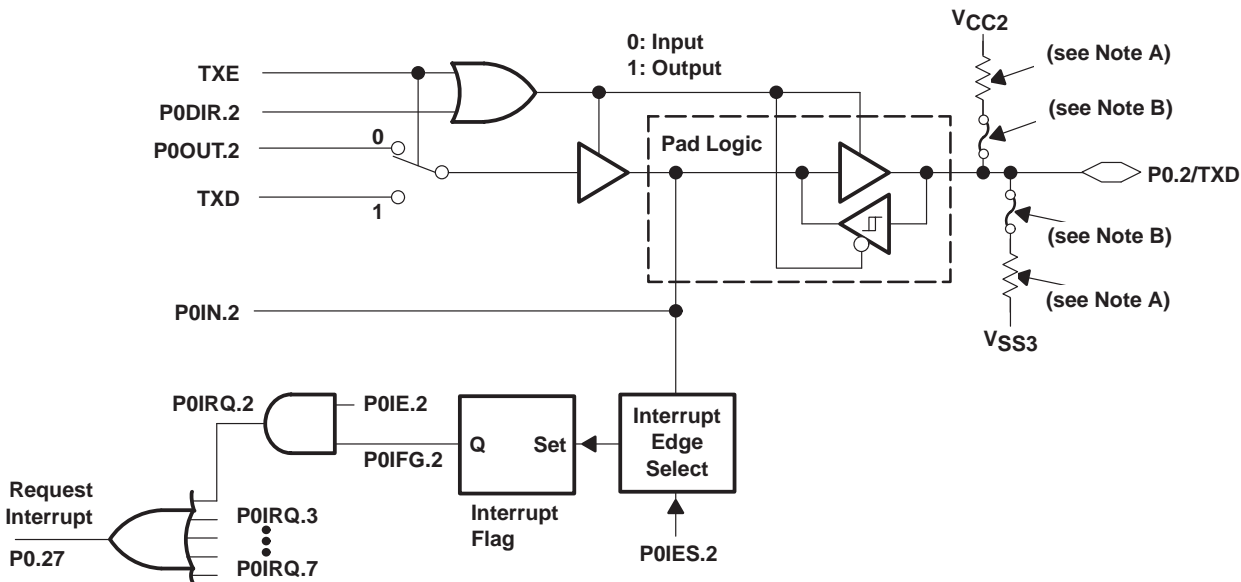

NOTES: A. Optional selection of pullup or pulldown resistors available on ROM (masked) versions.  
B. Fuses for the optional pullup and pulldown resistors can only be programmed at the factory.

Figure 9. Port P0, P0.2, Input/Output With Schmitt-Trigger

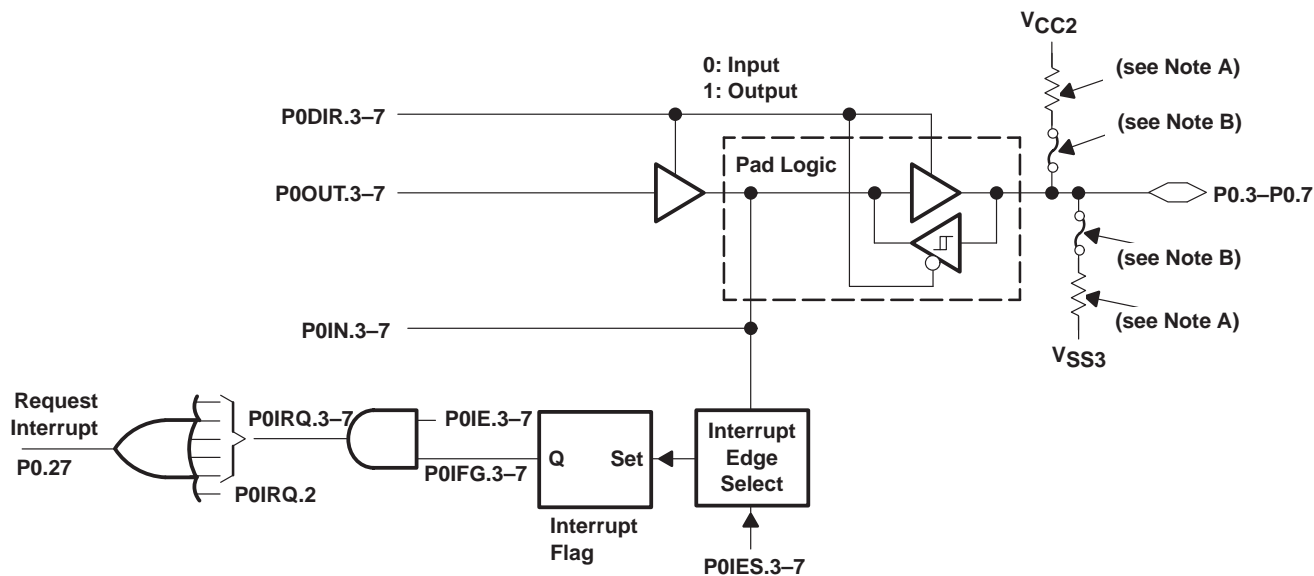

NOTES: A. Optional selection of pullup or pulldown resistors available on ROM (masked) versions.  
B. Fuses for the optional pullup and pulldown resistors can only be programmed at the factory.

Figure 10. Port P0, P0.3 to P0.7, Input/Output With Schmitt-Trigger

# MSP430C33x, MSP430P337A MIXED SIGNAL MICROCONTROLLERS

SLAS227A – OCTOBER 1999 – REVISED JUNE 2000

## typical input/output schematics (continued)

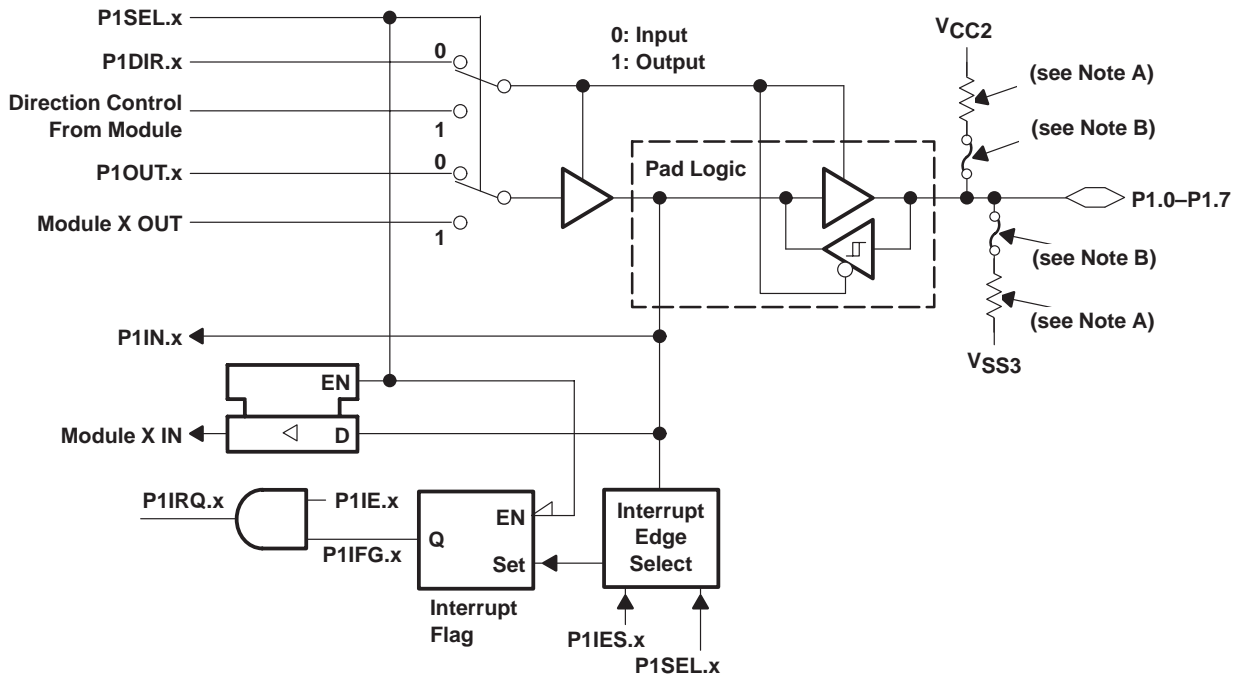

NOTES: A. Optional selection of pullup or pulldown resistors available on ROM (masked) versions.  
B. Fuses for the optional pullup and pulldown resistors can only be programmed at the factory.

PnSel.x	PnDIR.x	Dir. Control From Module	PnOUT.x	Module X OUT	PnIN.x	Module X IN	PnIE.x	PnIFG.x	PnIES.x
P1Sel.0	P1DIR.0	VSS1	P1OUT.0	VSS1	P1IN.0	Unused	P1IE.0	P1IFG.0	P1IES.0
P1Sel.1	P1DIR.1	VSS1	P1OUT.1	VSS1	P1IN.1	Unused	P1IE.1	P1IFG.1	P1IES.1
P1Sel.2	P1DIR.2	VSS1	P1OUT.2	VSS1	P1IN.2	Unused	P1IE.2	P1IFG.2	P1IES.2
P1Sel.3	P1DIR.3	VSS1	P1OUT.3	VSS1	P1IN.3	Unused	P1IE.3	P1IFG.3	P1IES.3
P1Sel.4	P1DIR.4	VSS1	P1OUT.4	VSS1	P1IN.4	Unused	P1IE.4	P1IFG.4	P1IES.4
P1Sel.5	P1DIR.5	VSS1	P1OUT.5	VSS1	P1IN.5	Unused	P1IE.5	P1IFG.5	P1IES.5
P1Sel.6	P1DIR.6	VSS1	P1OUT.6	VSS1	P1IN.6	Unused	P1IE.6	P1IFG.6	P1IES.6
P1Sel.7	P1DIR.7	VSS1	P1OUT.7	VSS1	P1IN.7	Unused	P1IE.7	P1IFG.7	P1IES.7

Figure 11. Port P1, P1.0 to P1.7, Input/Output With Schmitt-Trigger

typical input/output schematics (continued)

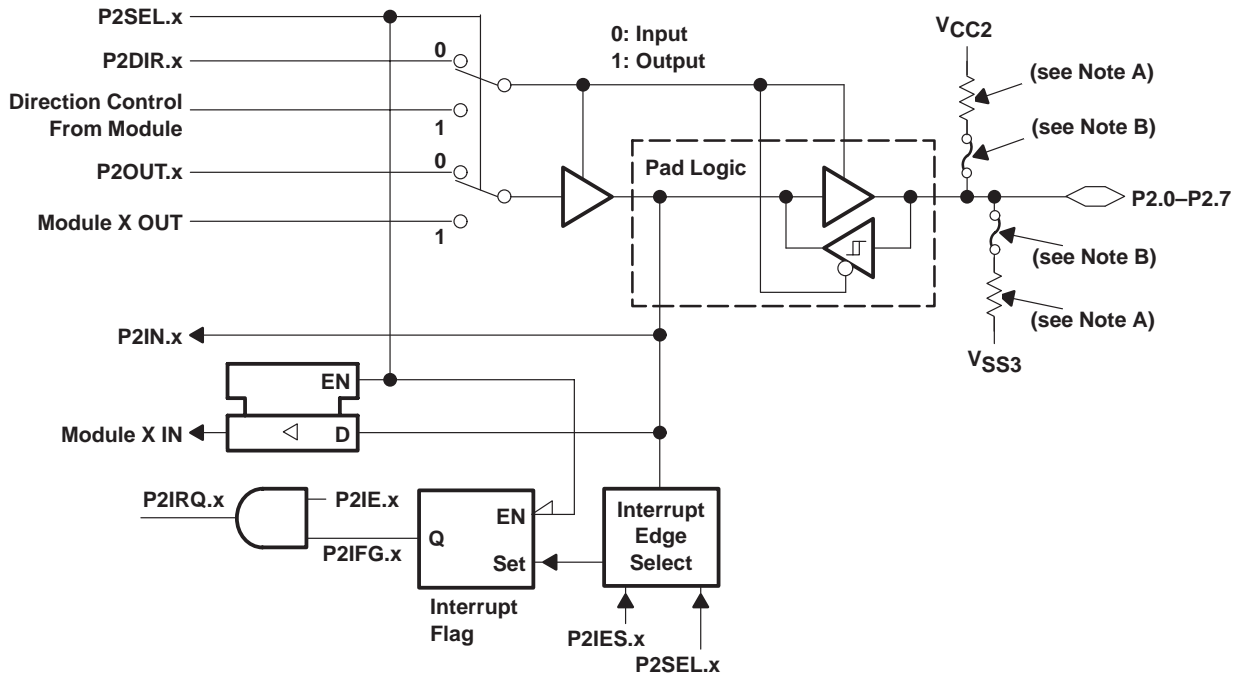

NOTES: A. Optional selection of pullup or pulldown resistors available on ROM (masked) versions.  
B. Fuses for the optional pullup and pulldown resistors can only be programmed at the factory.

PnSel.x	PnDIR.x	Dir. Control From Module	PnOUT.x	Module X OUT	PnIN.x	Module X IN	PnIE.x	PnIFG.x	PnIES.x
P2Sel.0	P2DIR.0	VSS1	P2OUT.0	VSS1	P2IN.0	Unused	P2IE.0	P2IFG.0	P2IES.0
P2Sel.1	P2DIR.1	VSS1	P2OUT.1	VSS1	P2IN.1	Unused	P2IE.1	P2IFG.1	P2IES.1
P2Sel.2	P2DIR.2	VSS1	P2OUT.2	VSS1	P2IN.2	Unused	P2IE.2	P2IFG.2	P2IES.2
P2Sel.3	P2DIR.3	VSS1	P2OUT.3	VSS1	P2IN.3	Unused	P2IE.3	P2IFG.3	P2IES.3
P2Sel.4	P2DIR.4	VSS1	P2OUT.4	VSS1	P2IN.4	Unused	P2IE.4	P2IFG.4	P2IES.4
P2Sel.5	P2DIR.5	VSS1	P2OUT.5	VSS1	P2IN.5	Unused	P2IE.5	P2IFG.5	P2IES.5
P2Sel.6	P2DIR.6	VSS1	P2OUT.6	VSS1	P2IN.6	Unused	P2IE.6	P2IFG.6	P2IES.6
P2Sel.7	P2DIR.7	VSS1	P2OUT.7	VSS1	P2IN.7	Unused	P2IE.7	P2IFG.7	P2IES.7

Figure 12. Port P2, P2.0 to P2.7, Input/Output With Schmitt-Trigger

# MSP430C33x, MSP430P337A MIXED SIGNAL MICROCONTROLLERS

SLAS227A – OCTOBER 1999 – REVISED JUNE 2000

## typical input/output schematics (continued)

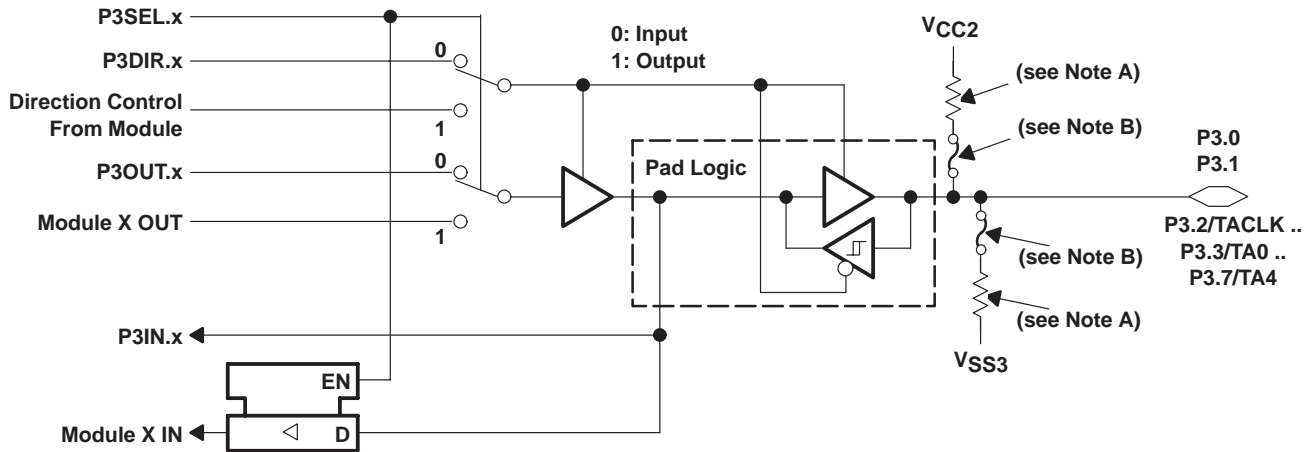

NOTES: A. Optional selection of pullup or pulldown resistors available on ROM (masked) versions.  
 B. Fuses for the optional pullup and pulldown resistors can only be programmed at the factory.

PnSel.x	PnDIR.x	Dir. Control From Module	PnOUT.x	Module X OUT	PnIN.x	Module X IN
P3Sel.0	P3DIR.0	P3DIR.0	P3OUT.0	VSS1	P3IN.0	Unused
P3Sel.1	P3DIR.1	P3DIR.1	P3OUT.1	VSS1	P3IN.1	Unused
P3Sel.2	P3DIR.2	P3DIR.2	P3OUT.2	VSS1	P3IN.2	TACLK†
P3Sel.3	P3DIR.3	P3DIR.3	P3OUT.3	Out0sig†	P3IN.3	CC10A‡
P3Sel.4	P3DIR.4	P3DIR.4	P3OUT.4	Out1sig†	P3IN.4	CC11A‡
P3Sel.5	P3DIR.5	P3DIR.5	P3OUT.5	Out2sig†	P3IN.5	CC12A‡
P3Sel.6	P3DIR.6	P3DIR.6	P3OUT.6	Out3sig†	P3IN.6	CC13A‡
P3Sel.7	P3DIR.7	P3DIR.7	P3OUT.7	Out4sig†	P3IN.7	CC14A‡

NOTE: All CCIB-signals in Timer\_A are connected to ACLK

† Signal from Timer\_A

‡ Signal to Timer\_A

**Figure 13. Port P3, P3.0 to P3.7, Input/Output With Schmitt-Trigger**

typical input/output schematics (continued)

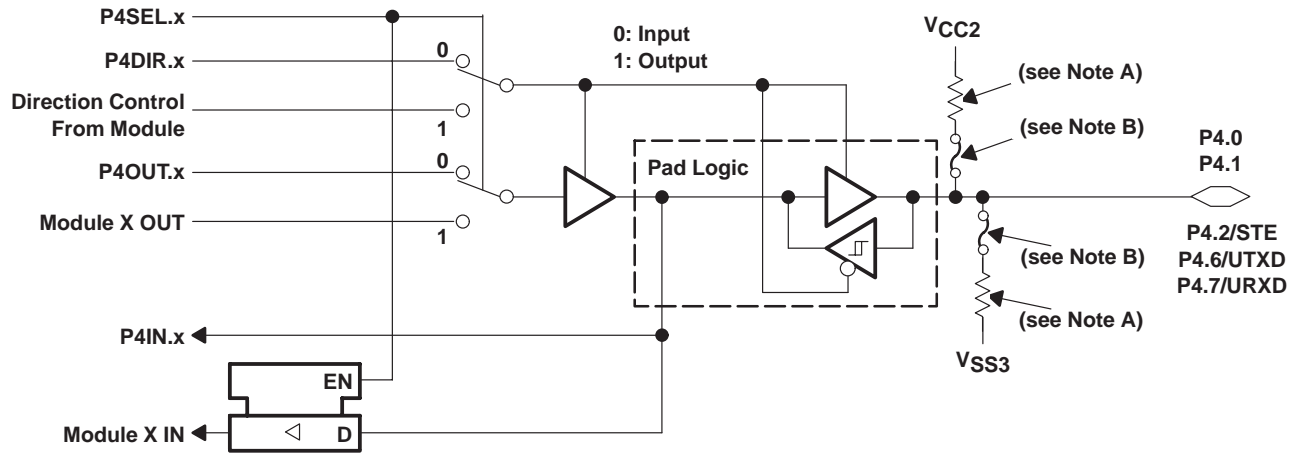

x: Bit Identifier, 0, 1, 2, 6 and 7 For Port P4

NOTES: A. Optional selection of pullup or pulldown resistors available on ROM (masked) versions.  
B. Fuses for the optional pullup and pulldown resistors can only be programmed at the factory.

PnSel.x	PnDIR.x	Dir. Control From Module	PnOUT.x	Module X OUT	PnIN.x	Module X IN
P4Sel.0	P4DIR.0	VSS1	P4OUT.0	VSS1	P4IN.0	Unused
P4Sel.1	P4DIR.1	VSS1	P4OUT.1	VSS1	P4IN.1	Unused
P4Sel.2	P4DIR.2	VSS1	P4OUT.2	VSS1	P4IN.2	STE
P4Sel.6	P4DIR.6	VCC1	P4OUT.6	UTXD†	P4IN.6	Unused
P4Sel.7	P4DIR.7	VSS1	P4OUT.7	VSS1	P4IN.7	URXD‡

† Output from USART module

‡ Input to USART module

Figure 14. Port P4, P4.0, P4.1, P4.2, P4.6 and P4.7, Input/Output With Schmitt-Trigger

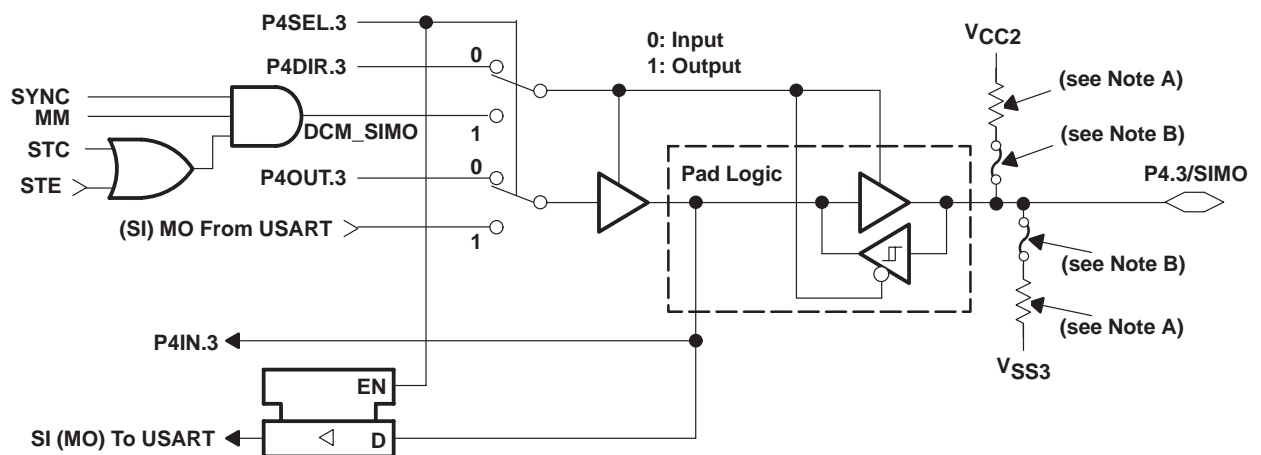

NOTES: A. Optional selection of pullup or pulldown resistors available on ROM (masked) versions.  
B. Fuses for the optional pullup and pulldown resistors can only be programmed at the factory.

Figure 15. Port P4, P4.3, Input/Output With Schmitt-Trigger

## typical input/output schematics (continued)

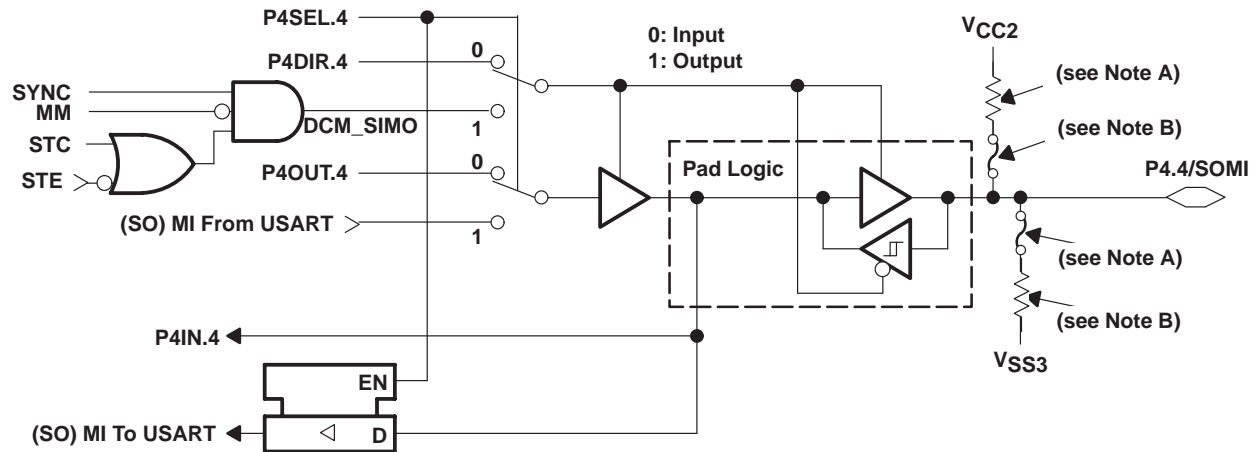

- A. Optional selection of pullup or pulldown resistors available on ROM (masked) versions.
- B. Fuses for the optional pullup and pulldown resistors can only be programmed at the factory.

**Figure 16. Port P4, P4.4, Input/Output With Schmitt-Trigger**

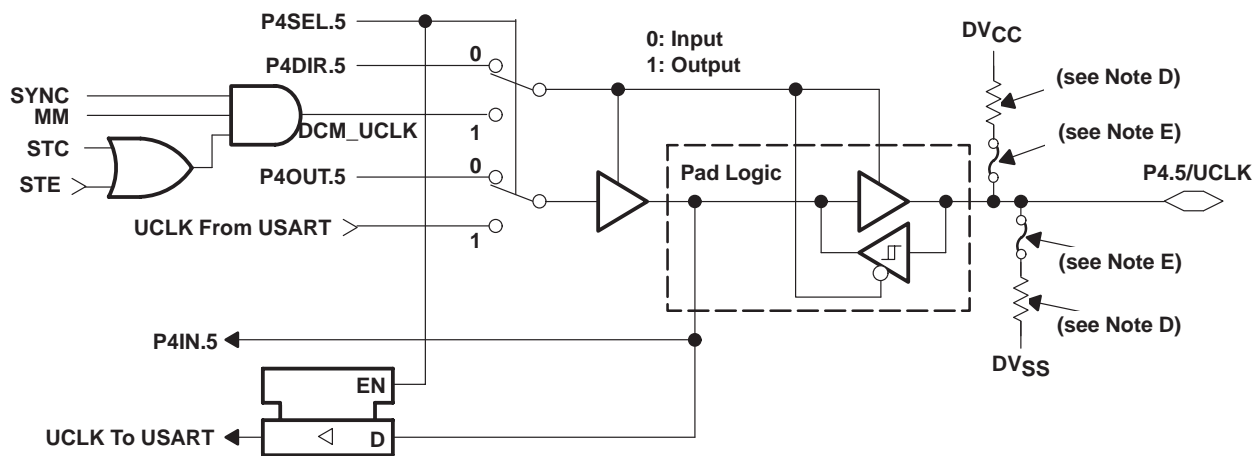

**Figure 17. Port P4, P4.5, Input/Output With Schmitt-Trigger**

- NOTES:
- A. UART mode: The clock can only be input if UART mode and UART function is selected, the direction of P4.5/UCLK is always input.
  - B. SPI, slave mode: The clock to UCLK is used to shift data in and out.
  - C. SPI, master mode: The clock shift data in and out is supplied on pin P4.5/UCLK for connected devices (in slave mode)
  - D. Optional selection of pullup or pulldown resistors available on ROM (masked) versions.
  - E. Fuses for the optional pullup and pulldown resistors can only be programmed at the factory.

typical input/output schematics (continued)

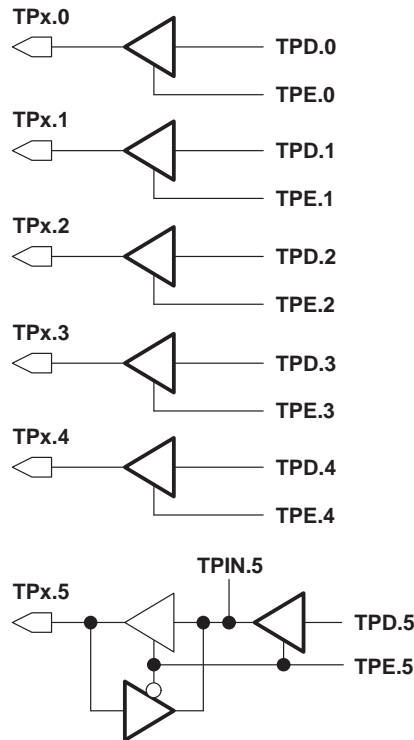

Figure 18. Timer/Port TP0.0 to TP0.5

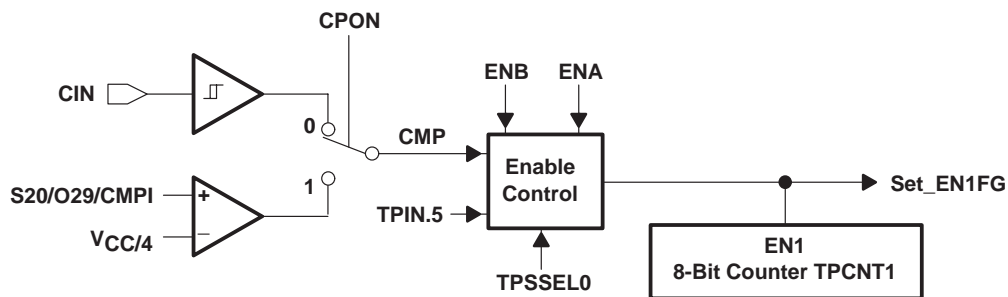

Figure 19. S29/O29/CMPI Pin Schematic

typical input/output schematics (continued)

JTAG fuse check mode

MSP430 devices that have the fuse on the TDI/VPP terminal have a fuse check mode that tests the continuity of the fuse the first time the JTAG port is accessed after a power-on reset (POR). When activated, a fuse check current,  $I_{TF}$ , of 1 mA at 3 V, 2.5 mA at 5 V can flow from the TDI/VPP pin to ground if the fuse is not burned. Care must be taken to avoid accidentally activating the fuse check mode and increasing overall system power consumption.

Activation of the fuse check mode occurs with the first negative edge on the TMS pin after power up or if the TMS is being held low during power up. The second positive edge on the TMS pin deactivates the fuse check mode. After deactivation, the fuse check mode remains inactive until another POR occurs. After each POR the fuse check mode has the potential to be activated.

Fuse check current may or may not flow continuously while the fuse check mode is active, depending on which type of device is in use and the state of the TMS pin.

For the mask ROM or C versions, the fuse check current will only flow when the fuse check mode is active and the TMS pin is in a low state (see Figure 20). Therefore, the additional current flow can be prevented by holding the TMS pin high (default condition).

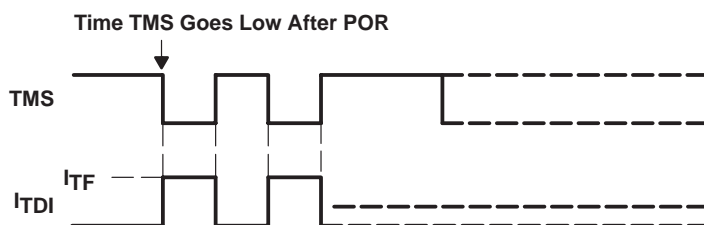

Figure 20. Fuse Check Mode Current, MSP430C33x

For the OTP or P versions, the fuse check current will flow continuously when fuse check mode is active, regardless of the state of the TMS pin, until the fuse check mode is deactivated with the second positive edge at the TMS pin (see Figure 21).

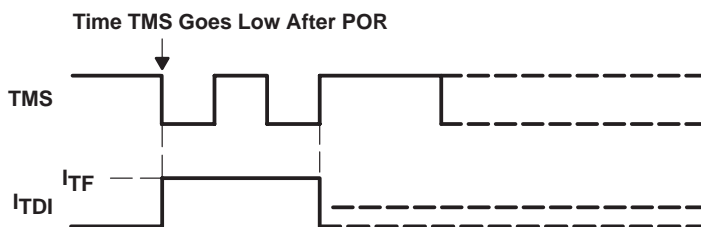

Figure 21. Fuse Check Mode Current, MSP430P337A

Care must be taken to avoid accidentally activating the fuse check mode, including guarding against EMI/ESD spikes that could cause signal edges on the TMS pin.

Configuration of TMS, TCK, TDI/VPP and TDO/TDI pins in applications.

	C3xx	P/E3xx
TDI	Open	68k, pulldown
TDO	Open	68k, pulldown
TMS	Open	Open
TCK	Open	Open

MECHANICAL DATA

PJM (R-PQFP-G100)

PLASTIC QUAD FLATPACK

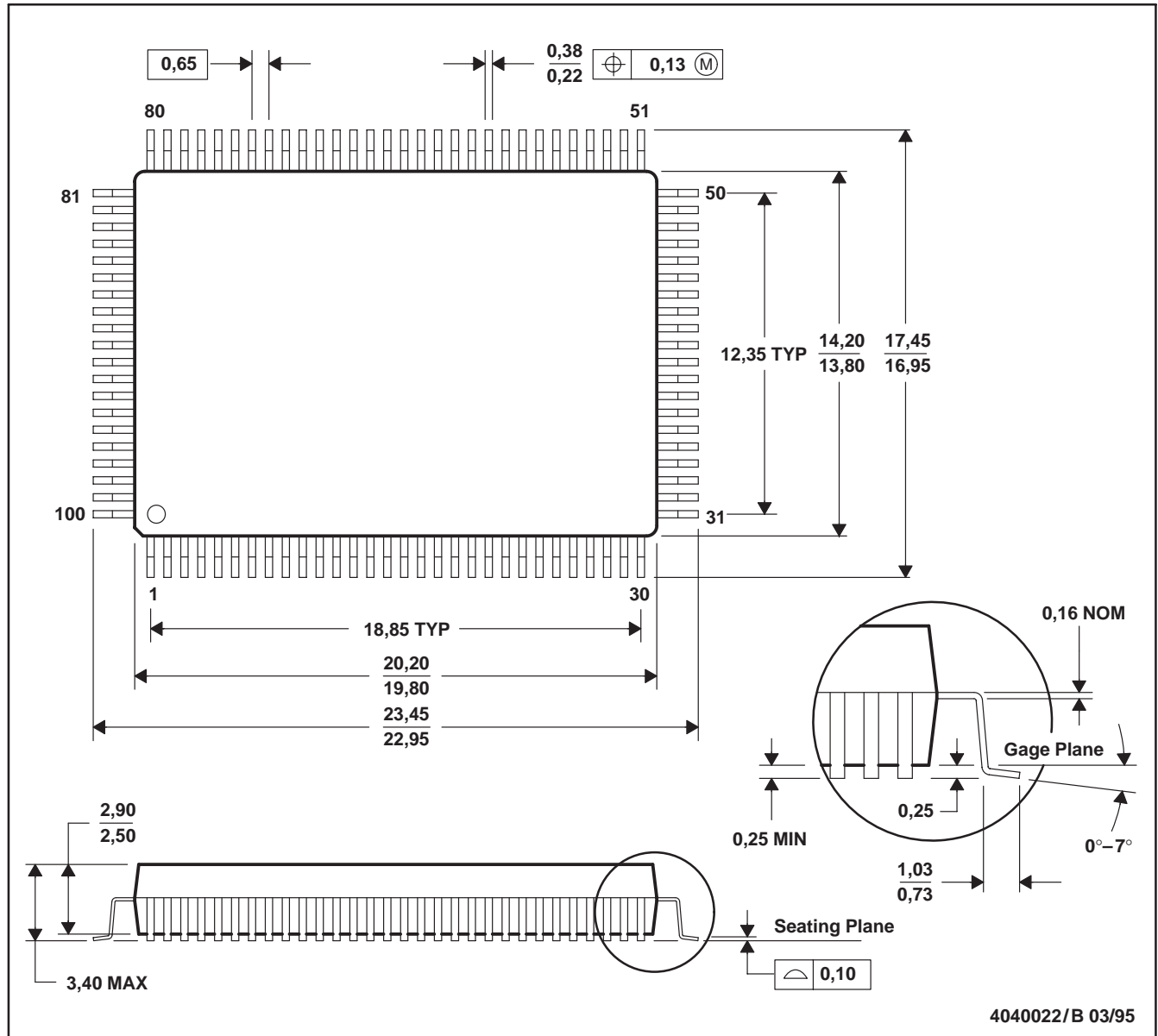

- NOTES: A. All linear dimensions are in millimeters.  
B. This drawing is subject to change without notice.  
C. Falls within JEDEC MS-022

# MSP430C33x, MSP430P337A MIXED SIGNAL MICROCONTROLLERS

SLAS227A – OCTOBER 1999 – REVISED JUNE 2000

## MECHANICAL DATA

HFD (S-GQFP-G100)

CERAMIC QUAD FLATPACK

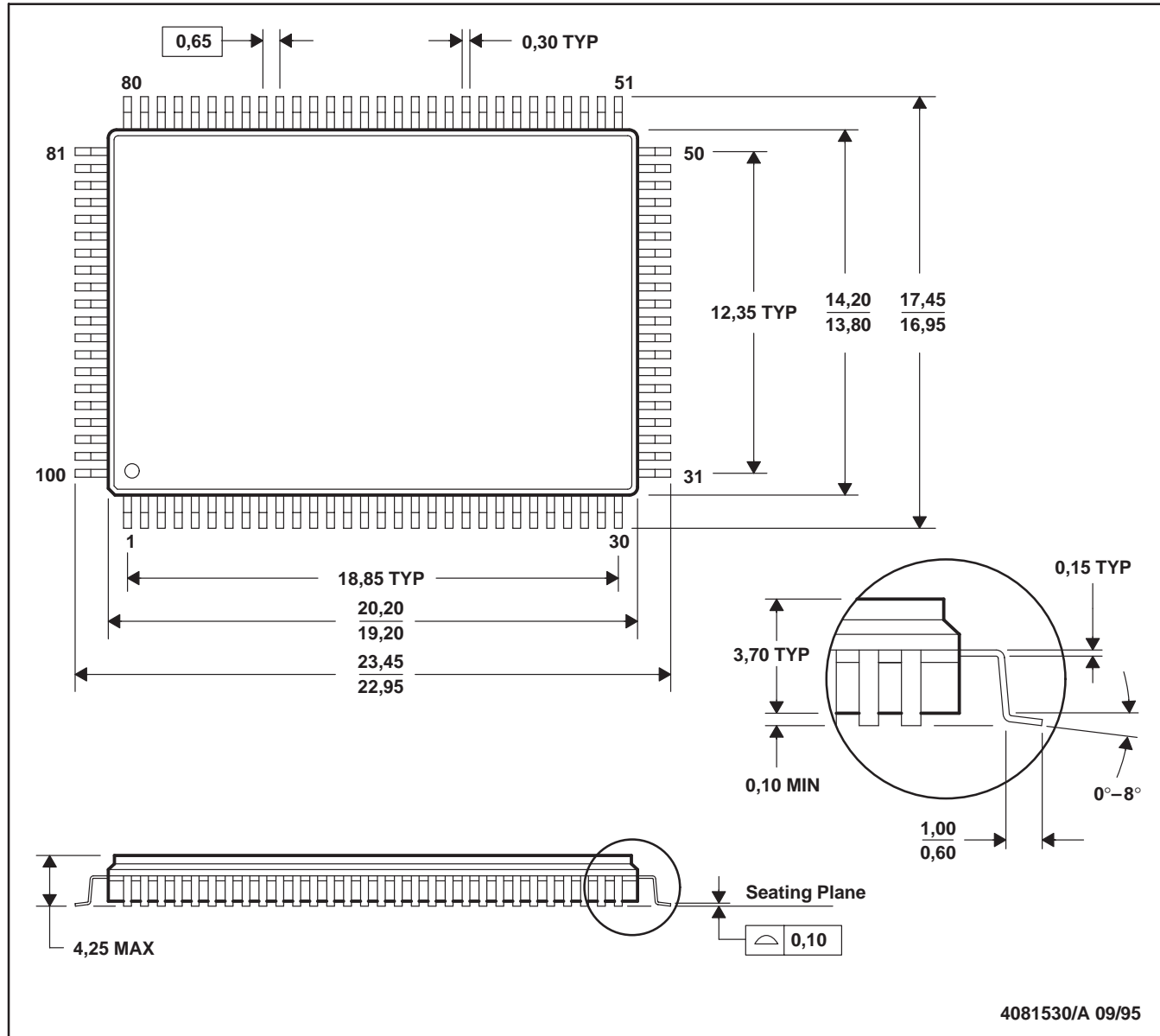

NOTES: A. All linear dimensions are in millimeters.  
B. This drawing is subject to change without notice.

**PACKAGING INFORMATION**

Orderable Device	Status <sup>(1)</sup>	Package Type	Package Drawing	Pins	Package Qty	Eco Plan <sup>(2)</sup>	Lead/Ball Finish	MSL Peak Temp <sup>(3)</sup>
MSP430P337AIPJM	ACTIVE	QFP	PJM	100	66	Green (RoHS & no Sb/Br)	CU NIPDAU	Level-3-260C-168 HR
MSP430P337AIPJMR	ACTIVE	QFP	PJM	100	400	Green (RoHS & no Sb/Br)	CU NIPDAU	Level-3-260C-168 HR
PMS430E337AHFD	ACTIVE	CFP	HFD	100	1	TBD	Call TI	Level-1-220C-UNLIM
PMS430E337HFD	OBSOLETE	CFP	HFD	100		TBD	Call TI	Call TI

<sup>(1)</sup> The marketing status values are defined as follows:

**ACTIVE:** Product device recommended for new designs.

**LIFEBUY:** TI has announced that the device will be discontinued, and a lifetime-buy period is in effect.

**NRND:** Not recommended for new designs. Device is in production to support existing customers, but TI does not recommend using this part in a new design.

**PREVIEW:** Device has been announced but is not in production. Samples may or may not be available.

**OBSOLETE:** TI has discontinued the production of the device.

<sup>(2)</sup> Eco Plan - The planned eco-friendly classification: Pb-Free (RoHS), Pb-Free (RoHS Exempt), or Green (RoHS & no Sb/Br) - please check <http://www.ti.com/productcontent> for the latest availability information and additional product content details.

**TBD:** The Pb-Free/Green conversion plan has not been defined.

**Pb-Free (RoHS):** TI's terms "Lead-Free" or "Pb-Free" mean semiconductor products that are compatible with the current RoHS requirements for all 6 substances, including the requirement that lead not exceed 0.1% by weight in homogeneous materials. Where designed to be soldered at high temperatures, TI Pb-Free products are suitable for use in specified lead-free processes.

**Pb-Free (RoHS Exempt):** This component has a RoHS exemption for either 1) lead-based flip-chip solder bumps used between the die and package, or 2) lead-based die adhesive used between the die and leadframe. The component is otherwise considered Pb-Free (RoHS compatible) as defined above.

**Green (RoHS & no Sb/Br):** TI defines "Green" to mean Pb-Free (RoHS compatible), and free of Bromine (Br) and Antimony (Sb) based flame retardants (Br or Sb do not exceed 0.1% by weight in homogeneous material)

<sup>(3)</sup> MSL, Peak Temp. -- The Moisture Sensitivity Level rating according to the JEDEC industry standard classifications, and peak solder temperature.

**Important Information and Disclaimer:**The information provided on this page represents TI's knowledge and belief as of the date that it is provided. TI bases its knowledge and belief on information provided by third parties, and makes no representation or warranty as to the accuracy of such information. Efforts are underway to better integrate information from third parties. TI has taken and continues to take reasonable steps to provide representative and accurate information but may not have conducted destructive testing or chemical analysis on incoming materials and chemicals. TI and TI suppliers consider certain information to be proprietary, and thus CAS numbers and other limited information may not be available for release.

In no event shall TI's liability arising out of such information exceed the total purchase price of the TI part(s) at issue in this document sold by TI to Customer on an annual basis.

PJM (R-PQFP-G100)

PLASTIC QUAD FLATPACK

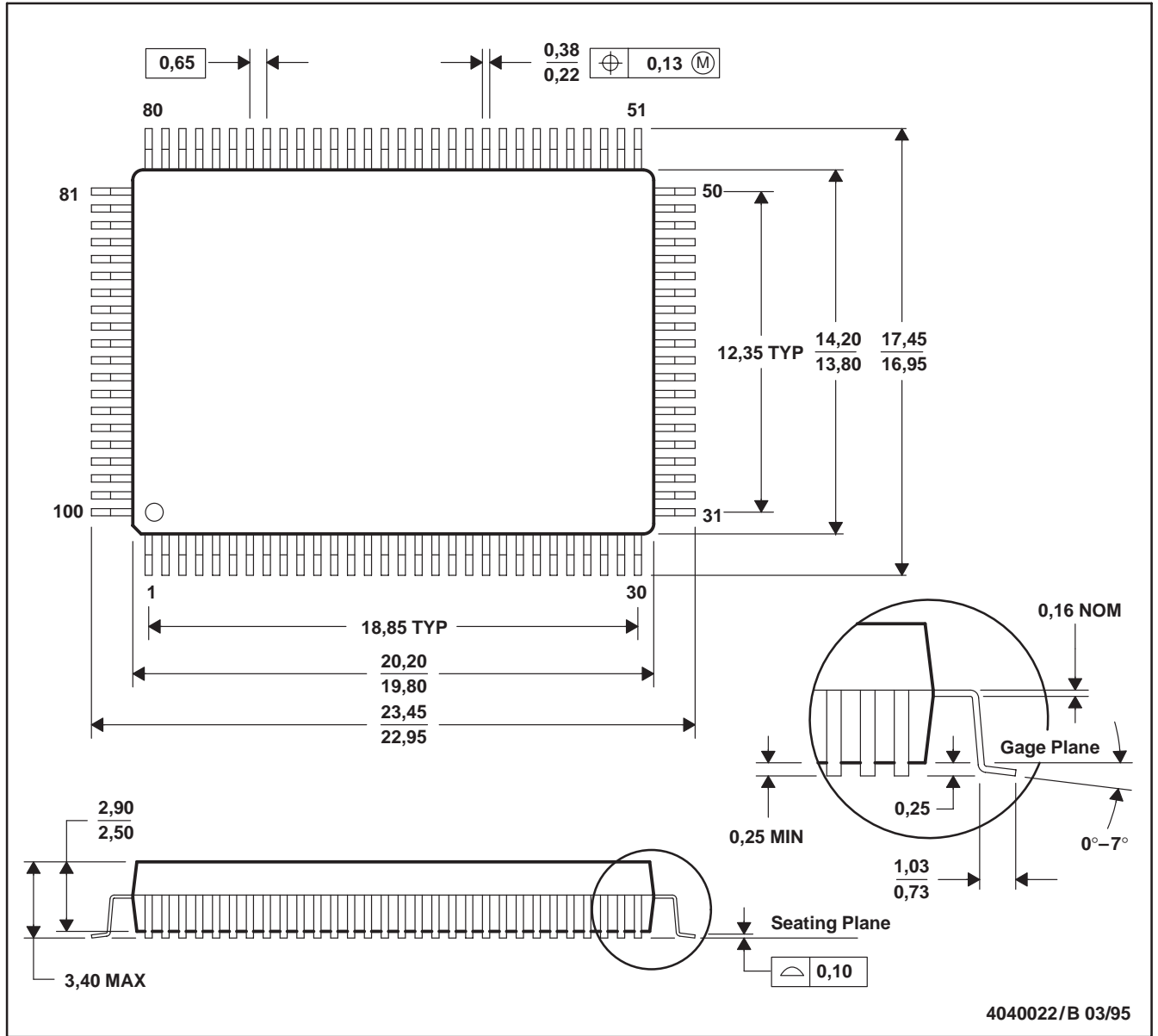

- NOTES: A. All linear dimensions are in millimeters.  
 B. This drawing is subject to change without notice.  
 C. Falls within JEDEC MS-022

## IMPORTANT NOTICE

Texas Instruments Incorporated and its subsidiaries (TI) reserve the right to make corrections, modifications, enhancements, improvements, and other changes to its products and services at any time and to discontinue any product or service without notice. Customers should obtain the latest relevant information before placing orders and should verify that such information is current and complete. All products are sold subject to TI's terms and conditions of sale supplied at the time of order acknowledgment.

TI warrants performance of its hardware products to the specifications applicable at the time of sale in accordance with TI's standard warranty. Testing and other quality control techniques are used to the extent TI deems necessary to support this warranty. Except where mandated by government requirements, testing of all parameters of each product is not necessarily performed.

TI assumes no liability for applications assistance or customer product design. Customers are responsible for their products and applications using TI components. To minimize the risks associated with customer products and applications, customers should provide adequate design and operating safeguards.

TI does not warrant or represent that any license, either express or implied, is granted under any TI patent right, copyright, mask work right, or other TI intellectual property right relating to any combination, machine, or process in which TI products or services are used. Information published by TI regarding third-party products or services does not constitute a license from TI to use such products or services or a warranty or endorsement thereof. Use of such information may require a license from a third party under the patents or other intellectual property of the third party, or a license from TI under the patents or other intellectual property of TI.

Reproduction of TI information in TI data books or data sheets is permissible only if reproduction is without alteration and is accompanied by all associated warranties, conditions, limitations, and notices. Reproduction of this information with alteration is an unfair and deceptive business practice. TI is not responsible or liable for such altered documentation. Information of third parties may be subject to additional restrictions.

Resale of TI products or services with statements different from or beyond the parameters stated by TI for that product or service voids all express and any implied warranties for the associated TI product or service and is an unfair and deceptive business practice. TI is not responsible or liable for any such statements.

TI products are not authorized for use in safety-critical applications (such as life support) where a failure of the TI product would reasonably be expected to cause severe personal injury or death, unless officers of the parties have executed an agreement specifically governing such use. Buyers represent that they have all necessary expertise in the safety and regulatory ramifications of their applications, and acknowledge and agree that they are solely responsible for all legal, regulatory and safety-related requirements concerning their products and any use of TI products in such safety-critical applications, notwithstanding any applications-related information or support that may be provided by TI. Further, Buyers must fully indemnify TI and its representatives against any damages arising out of the use of TI products in such safety-critical applications.

TI products are neither designed nor intended for use in military/aerospace applications or environments unless the TI products are specifically designated by TI as military-grade or "enhanced plastic." Only products designated by TI as military-grade meet military specifications. Buyers acknowledge and agree that any such use of TI products which TI has not designated as military-grade is solely at the Buyer's risk, and that they are solely responsible for compliance with all legal and regulatory requirements in connection with such use.

TI products are neither designed nor intended for use in automotive applications or environments unless the specific TI products are designated by TI as compliant with ISO/TS 16949 requirements. Buyers acknowledge and agree that, if they use any non-designated products in automotive applications, TI will not be responsible for any failure to meet such requirements.

Following are URLs where you can obtain information on other Texas Instruments products and application solutions:

### Products

Amplifiers	<a href="http://amplifier.ti.com">amplifier.ti.com</a>
Data Converters	<a href="http://dataconverter.ti.com">dataconverter.ti.com</a>
DSP	<a href="http://dsp.ti.com">dsp.ti.com</a>
Clocks and Timers	<a href="http://www.ti.com/clocks">www.ti.com/clocks</a>
Interface	<a href="http://interface.ti.com">interface.ti.com</a>
Logic	<a href="http://logic.ti.com">logic.ti.com</a>
Power Mgmt	<a href="http://power.ti.com">power.ti.com</a>
Microcontrollers	<a href="http://microcontroller.ti.com">microcontroller.ti.com</a>
RFID	<a href="http://www.ti-rfid.com">www.ti-rfid.com</a>
RF/IF and ZigBee® Solutions	<a href="http://www.ti.com/lprf">www.ti.com/lprf</a>

### Applications

Audio	<a href="http://www.ti.com/audio">www.ti.com/audio</a>
Automotive	<a href="http://www.ti.com/automotive">www.ti.com/automotive</a>
Broadband	<a href="http://www.ti.com/broadband">www.ti.com/broadband</a>
Digital Control	<a href="http://www.ti.com/digitalcontrol">www.ti.com/digitalcontrol</a>
Medical	<a href="http://www.ti.com/medical">www.ti.com/medical</a>
Military	<a href="http://www.ti.com/military">www.ti.com/military</a>
Optical Networking	<a href="http://www.ti.com/opticalnetwork">www.ti.com/opticalnetwork</a>
Security	<a href="http://www.ti.com/security">www.ti.com/security</a>
Telephony	<a href="http://www.ti.com/telephony">www.ti.com/telephony</a>
Video & Imaging	<a href="http://www.ti.com/video">www.ti.com/video</a>
Wireless	<a href="http://www.ti.com/wireless">www.ti.com/wireless</a>

Mailing Address: Texas Instruments, Post Office Box 655303, Dallas, Texas 75265  
Copyright © 2008, Texas Instruments Incorporated

## Looking for pricing, stock, or lifecycle information?

Click below to explore more details on WIN SOURCE:

 [View MSP430P337AIPJM on WIN SOURCE](#)

 [Texas Instruments](#) Information

## Optimize Your Supply Chain with WIN SOURCE Solutions

-  Global Sourcing Solution
-  Obsolete Management
-  Cost Control Management
-  Shortage Management
-  Alternative Solution
-  Excess Inventory Management