



# THE DATASHEET OF MSP430P315IDL



# MSP430x31x MIXED SIGNAL MICROCONTROLLERS

SLAS165D – FEBRUARY 1998 – REVISED APRIL 2000

- Low Supply Voltage Range 2.5 V – 5.5 V
- Ultra Low-Power Consumption
- Low Operation Current, 400  $\mu$ A at 1 MHz, 3 V
- Five Power Saving Modes: (Standby Mode: 1.3  $\mu$ A, RAM Retention/Off Mode: 0.1  $\mu$ A)
- Wakeup From Standby Mode in 6  $\mu$ s Maximum
- 16-Bit RISC Architecture, 300 ns Instruction Cycle Time
- Single Common 32 kHz Crystal, Internal System Clock up to 3.3 MHz
- Integrated LCD Driver for up to 64 or 92 Segments
- Slope A/D Converter With External Components
- Serial Onboard Programming
- Program Code Protection by Security Fuse
- Family Members Include:  
MSP430C311S: 2k Byte ROM, 128 Byte RAM  
MSP430C312: 4k Byte ROM, 256 Byte RAM  
MSP430C313: 8k Byte ROM, 256 Byte RAM  
MSP430C314: 12k Byte ROM, 512 Byte RAM  
MSP430C315: 16k Byte ROM, 512 Byte RAM  
MSP430P313: 8k Byte OTP, 256 Byte RAM†  
MSP430P315: 16k Byte OTP, 512 Byte RAM  
MSP430P315S: 16k Byte OTP, 512 Byte RAM
- EPROM Version Available for Prototyping :  
PMS430E313FZ†, PMS430E315FZ
- Available in:  
56-Pin Plastic Small-Outline Package (SSOP),  
48-Pin SSOP (MSP430C311S, MSP430P315S),  
68-Pin J-Leaded Ceramic Chip Carrier (JLCC) Package (EPROM Only)

DL PACKAGE  
(56-PIN TOP VIEW)

TDO/TDI	1	56	NC
TDI/VPP	2	55	COM3
TMS	3	54	COM2
TCK	4	53	COM1
RST/NMI	5	52	COM0
XBUF	6	51	S27/O27/CMPI
V <sub>ss</sub>	7	50	S26/O26
V <sub>CC</sub>	8	49	S23/O23
R23	9	48	S22/O22
R13	10	47	S18/O18
Xin	11	46	S17/O17
Xout/TCLK	12	45	S16/O16
P0.0	13	44	S15/O15
P0.1/RXD	14	43	S14/O14
P0.2/TXD	15	42	S13/O13
P0.3	16	41	S12/O12
P0.4	17	40	S11/O11
P0.5	18	39	S10/O10
P0.6	19	38	S9/O9
P0.7	20	37	S8/O8
TP0.0	21	36	S7/O7
TP0.1	22	35	S6/O6
TP0.2	23	34	S5/O5
TP0.3	24	33	S4/O4
TP0.4	25	32	S3/O3
TP0.5	26	31	S2/O2
CIN	27	30	S1
NC	28	29	S0

DL PACKAGE  
(48-PIN TOP VIEW)

TDI/VPP	1	48	TDO/TDI
TMS	2	47	COM3
TCK	3	46	COM2
RST/NMI	4	45	COM1
XBUF	5	44	COM0
V <sub>ss</sub>	6	43	S27/O27/CMPI
V <sub>CC</sub>	7	42	NC
R23	8	41	V <sub>ss</sub>
R13	9	40	NC
Xin	10	39	S16/O16
Xout/TCLK	11	38	S15/O15
P0.1/RXD	12	37	S14/O14
P0.2/TXD	13	36	S13/O13
P0.3	14	35	S12/O12
P0.4	15	34	S11/O11
P0.5	16	33	S10/O10
P0.6	17	32	S9/O9
NC	18	31	S8/O8
TP0.0	19	30	S7/O7
TP0.1	20	29	S6/O6
TP0.2	21	28	S5/O5
TP0.3	22	27	S4/O4
TP0.5	23	26	S3/O3
CIN	24	25	S2/O2

NC – No internal connection

## description

The MSP430 is an ultralow-power mixed signal microcontroller family consisting of several devices that feature different sets of modules targeted to various applications. The microcontroller is designed to be battery operated for an extended application lifetime. With 16-bit RISC architecture, 16-bit integrated registers on the CPU, and a constant generator, the MSP430 achieves maximum code efficiency. The digitally-controlled oscillator, together with the frequency-locked-loop (FLL), provides a wakeup from a low-power mode to active mode in less than 6  $\mu$ s.



Please be aware that an important notice concerning availability, standard warranty, and use in critical applications of Texas Instruments semiconductor products and disclaimers thereto appears at the end of this data sheet.

† MSP430P313/E313 not recommended for new designs – replaced by MSP430P315/E315.

PRODUCTION DATA information is current as of publication date. Products conform to specifications per the terms of Texas Instruments standard warranty. Production processing does not necessarily include testing of all parameters.

**TEXAS  
INSTRUMENTS**

POST OFFICE BOX 655303 • DALLAS, TEXAS 75265  
POST OFFICE BOX 1443 • HOUSTON, TEXAS 77251-1443

Copyright © 2000, Texas Instruments Incorporated

# MSP430x31x MIXED SIGNAL MICROCONTROLLERS

SLAS165D – FEBRUARY 1998 – REVISED APRIL 2000

## description (continued)

Typical applications include sensor systems that capture analog signals, converting them to digital values, and then processes the data and displays them or transmits them to a host system. The timer/port module provides single-slope A/D conversion capability for resistive sensors.

### AVAILABLE OPTIONS

T <sub>A</sub>	PACKAGED DEVICES		
	SSOP 48-Pin (DL)	SSOP 56-Pin (DL)	JLCC 68-Pin (FZ)
-40°C to 85°C	MSP430C311SIDL MSP430P315SIDL	MSP430C312IDL MSP430C313IDL MSP430C314IDL MSP430C315IDL MSP430P313IDL† MSP430P315IDL	
25°C	—	—	PMS430E313FZ† PMS430E315FZ

† MSP430P313/E313 not recommended for new designs – replaced by MSP430P315/E315.

## functional block diagram

### MSP430C312,313,314,315 and MSP430P313†,315 and PMS430E313,315

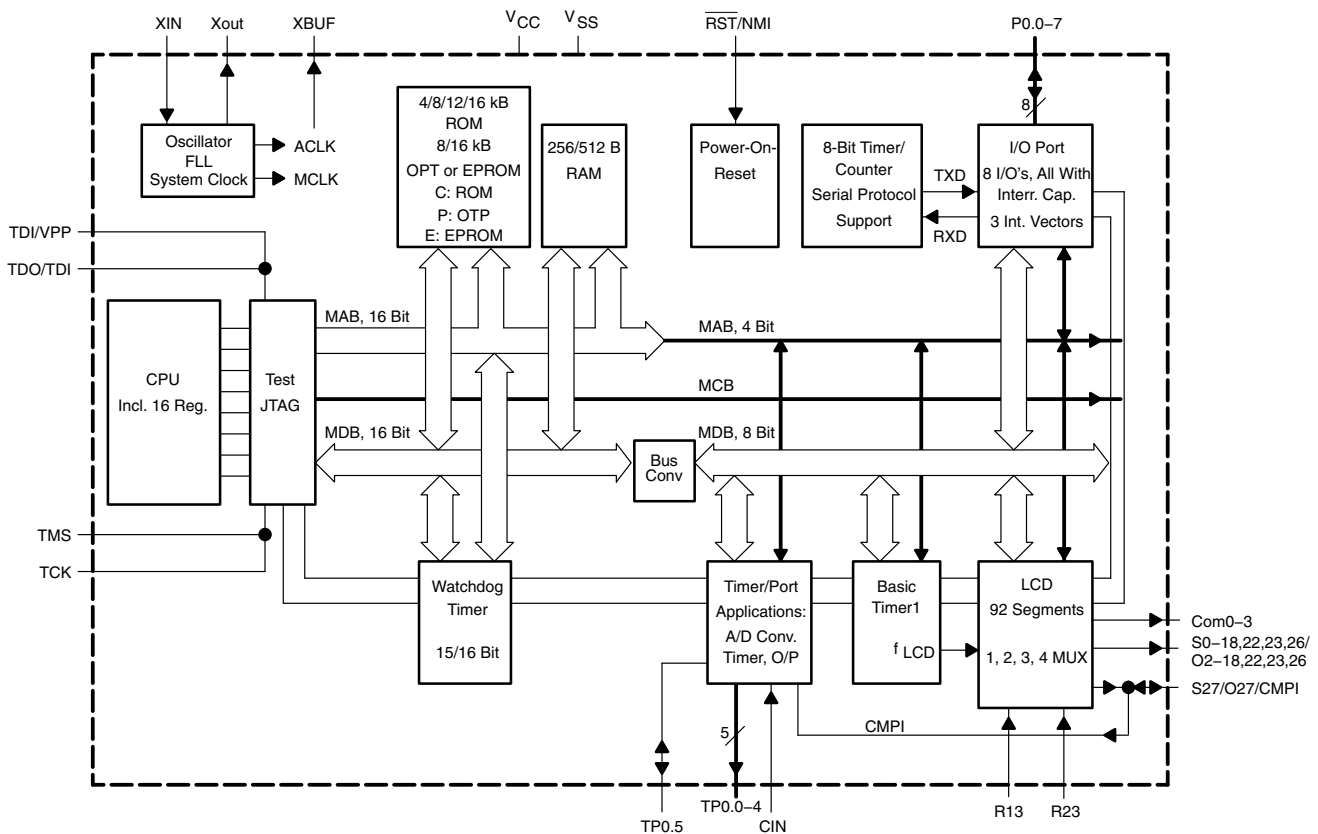

POST OFFICE BOX 655303 • DALLAS, TEXAS 75265  
POST OFFICE BOX 1443 • HOUSTON, TEXAS 77251-1443

### Terminal Functions

#### MSP430C312, MSP430C313†, MSP430C314, MSP430C315, MSP430P313†, MSP430P315

##### 56-pin SSOP package

TERMINAL NAME	NO.	I/O	DESCRIPTION
CIN	27	I	Counter enable. CIN input enables counter (TPCNT1) (timer/port).
COM0–COM3	52–55	O	Common output pins. COM0–COM3 are used for LCD back planes.
P0.0	13	I/O	General-purpose digital I/O pin
P0.1/RXD	14	I/O	General-purpose digital I/O pin, receive data input port – 8-bit (timer/counter)
P0.2/TXD	15	I/O	General-purpose digital I/O pin, transmit data output port – 8-bit (timer/counter)
P0.3–P0.7	16–20	I/O	Five general-purpose digital I/O pins, bit 3–7
R23	9	I	Input of second positive analog LCD level (V2) (LCD)
R13	10	I	Input of third positive analog LCD level (V3 of V4) (LCD)
RST/NMI	5	I	Reset input or nonmaskable interrupt input
S0	29	O	Segment line S0 (LCD)
S1	30	O	Segment line S1 (LCD)
S2/O2–S5/O5	31–34	O	Segment lines (S2 to S5) or digital output port O2 to O5, group 1 (LCD)
S6/O6–S9/O9	35–38	O	Segment lines (S6 to S9) or digital output port O6 to O9, group 2 (LCD)
S10/O10–S13/O13	39–42	O	Segment lines (S10 to S13) or digital output port O10 to O13, group 3 (LCD)
S14/O14–S17/O17	43–46	O	Segment lines (S14 to S17) or digital output port O14 to O17, group 4 (LCD)
S18/O18	47	O	Segment line (S18) or digital output port O18, group 5 (LCD)
S22/O22–S23/O23	48,49	O	Segment lines (S22 to S23) or digital output port O22 to O23, group 6 (LCD)
S26/O26	50	O	Segment line (S26) or digital output port O26, group 7 (LCD)
S27/O27/CMPI	51	I/O	Segment line (S27) or digital output port O27 group 7, can be used as a comparator input port CMPI (timer/port)
TCK	4	I	Test clock. TCK is a clock input terminal for device programming and test.
TDI/VPP	2	I	Test data input port. TDI/VPP is used as a data input terminal or an input for programming voltage.
TDO/TDI	1	I/O	Test data output port. TDO/TDI is used as a data output terminal or as a data input during programming.
TMS	3	I	Test mode select. TMS is an input terminal for device programming and test.
TP0.0	21	O/Z	General-purpose 3-state digital output port, bit 0 (timer/port)
TP0.1	22	O/Z	General-purpose 3-state digital output port, bit 1 (timer/port)
TP0.2	23	O/Z	General-purpose 3-state digital output port, bit 2 (timer/port)
TP0.3	24	O/Z	General-purpose 3-state digital output port, bit 3 (timer/port)
TP0.4	25	O/Z	General-purpose 3-state digital output port, bit 4 (timer/port)
TP0.5	26	I/O/Z	General-purpose 3-state digital I/O pin, bit 5 (timer/port)
V <sub>CC</sub>	8		Supply voltage
V <sub>SS</sub>	7		Ground reference
XBUF	6	O	Clock signal output of system clock (MCLK) or crystal clock (ACLK)
Xin	11	I	Input terminal of crystal oscillator
Xout/TCLK	12	I/O	Output terminal of crystal oscillator or test clock input

† MSP430P313/E313 not recommended for new designs – replaced by MSP430P315/E315.

# MSP430x31x MIXED SIGNAL MICROCONTROLLERS

SLAS165D – FEBRUARY 1998 – REVISED APRIL 2000

## functional block diagram

### MSP430C311S and MSP430P315S

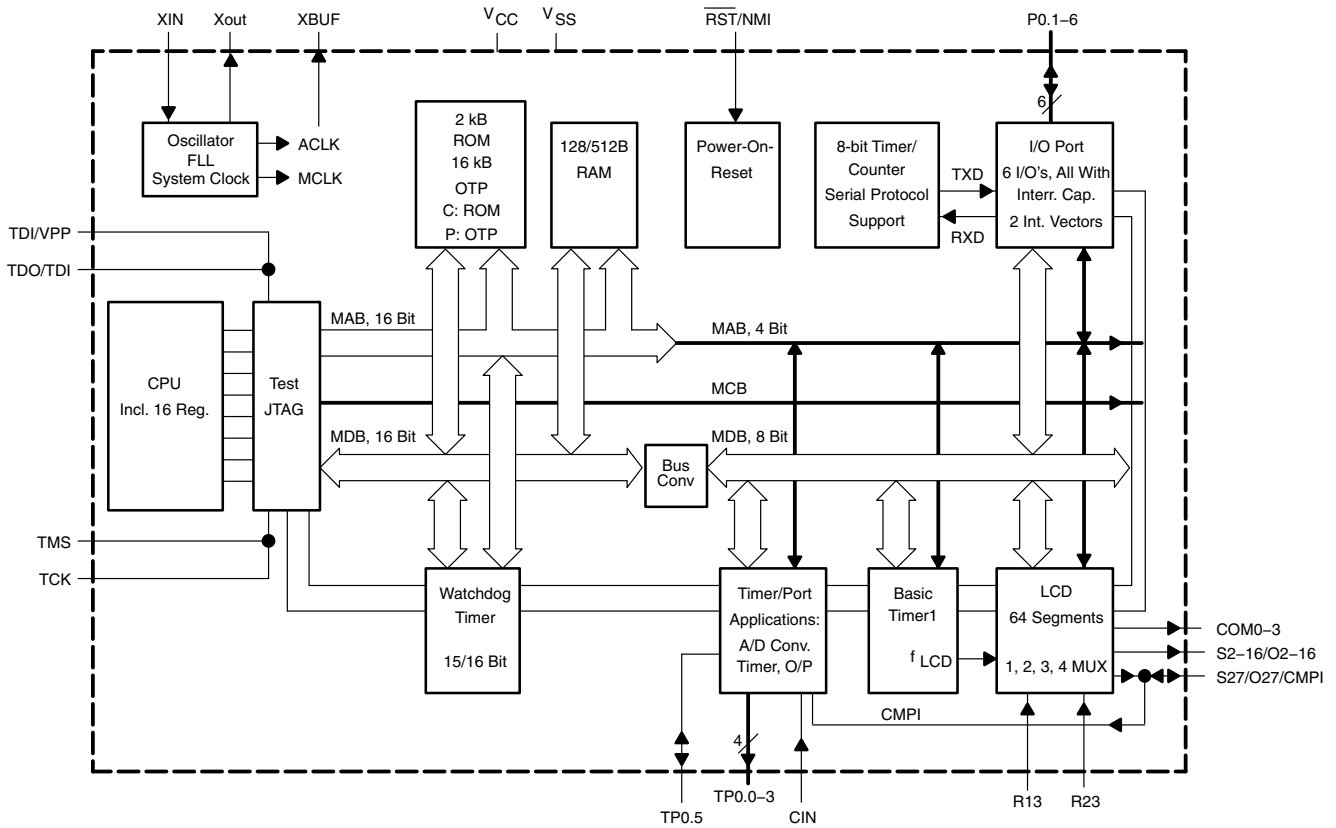

POST OFFICE BOX 655303 • DALLAS, TEXAS 75265  
POST OFFICE BOX 1443 • HOUSTON, TEXAS 77251-1443

### Terminal Functions

#### MSP430C311S, MSP430P315S

##### 48-pin SSOP package

TERMINAL NAME	NO.	I/O	DESCRIPTION
CIN	24	I	Counter enable. CIN input enables counter (TPCNT1) (timer/port).
COM0–COM3	44–47	O	Common output pins, COM0–COM3 are used for LCD back planes.
P0.1/RXD	12	I/O	General-purpose digital I/O pin, receive data input port – 8-Bit (timer/counter)
P0.2/TXD	13	I/O	General-purpose digital I/O pin, transmit data output port – 8-Bit (timer/counter)
P0.3	14	I/O	General-purpose digital I/O pins, bit 3
P0.4	15	I/O	General-purpose digital I/O pins, bit 4
P0.5	16	I/O	General-purpose digital I/O pins, bit 5
P0.6	17	I/O	General-purpose digital I/O pins, bit 6
R23	8	I	Input of second positive analog LCD level (V2) (LCD)
R13	9	I	Input of third positive analog LCD level (V3 of V4) (LCD)
$\overline{\text{RST}}/\text{NMI}$	4	I	Reset input or nonmaskable interrupt input
S2/O2–S5/O5	25–28	O	Segment lines (S2 to S5) or digital output port O2 to O5, group 1 (LCD)
S6/O6–S9/O9	29–32	O	Segment lines (S6 to S9) or digital output port O6 to O9, group 2 (LCD)
S10/O10–S13/O13	33–36	O	Segment lines (S10 to S13) or digital output port O10 to O13, group 3 (LCD)
S14/O14–S16/O16	37–39	O	Segment lines (S14 to S17) or digital output port O14 to O17, group 4 (LCD)
S27/O27/CMPI	43	I/O	Segment line (S27) or digital output port O27 group 7, can be used as a comparator input port CMPI (timer/port)
TCK	3	I	Test clock. TCK is a clock input terminal for device programming and test.
TDI/VPP	1	I	Test data input port. TDI/VPP is used as a data input terminal or an input for programming voltage.
TDO/TDI	48	I/O	Test data output port. TDO/TDI is used as a data output terminal or as a data input during programming.
TMS	2	I	Test mode select. TMS is an input terminal for device programming and test.
TP0.0	19	O/Z	General-purpose 3-state digital output port, bit 0 (timer/port)
TP0.1	20	O/Z	General-purpose 3-state digital output port, bit 1 (timer/port)
TP0.2	21	O/Z	General-purpose 3-state digital output port, bit 2 (timer/port)
TP0.3	22	O/Z	General-purpose 3-state digital output port, bit 3 (timer/port)
TP0.5	23	I/O/Z	General-purpose 3-state digital I/O pin, bit 5 (timer/port)
V <sub>CC</sub>	7		Supply voltage
V <sub>SS</sub>	6, 41		Ground references
XBUF	5	O	Clock signal output of system clock (MCLK) or crystal clock (ACLK)
Xin	10	I	Input terminal of crystal oscillator
Xout/TCLK	11	I/O	Output terminal of crystal oscillator or test clock input

# MSP430x31x MIXED SIGNAL MICROCONTROLLERS

SLAS165D – FEBRUARY 1998 – REVISED APRIL 2000

## short-form description

### processing unit

The processing unit is based on a consistent and orthogonal designed CPU and instruction set. This design structure results in a RISC-like architecture, highly transparent to the application development and distinguishable by the ease of programming. All operations other than program-flow instructions are consequently performed as register operations in conjunction with seven addressing modes for source and four modes for destination operand.

### CPU

Sixteen registers located inside the CPU provide reduced instruction execution time. This reduces a register-register operation execution time to one cycle of the processor frequency.

Four registers are reserved for special use as a program counter, a stack pointer, a status register, and a constant generator. The remaining ones are available as general-purpose registers.

Peripherals connected to the CPU using a data address and control bus can be handled easily with all instructions for memory manipulation.

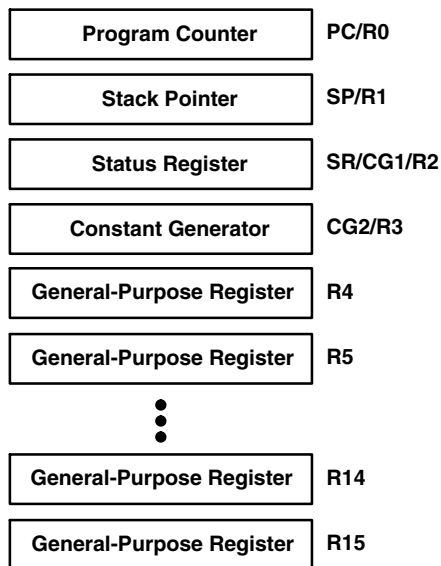

### instruction set

The instruction set for this register-register architecture provides a powerful and easy-to-use assembly language. The instruction set consists of 51 instructions with three formats and seven addressing modes. Table 1 provides a summation and example of the three types of instruction formats; the addressing modes are listed in Table 2.

**Table 1. Instruction Word Formats**

Dual operands, source-destination	e.g. ADD R4, R5	R4 + R5 → R5
Single operands, destination only	e.g. CALL R8	PC → (TOS), R8 → PC
Relative jump, un-/conditional	e.g. JNE	Jump-on equal bit = 0

Each instruction that operates on word and byte data is identified by the suffix B.

Examples:	Instructions for word operation	Instructions for byte operation
	MOV EDE,TONI	MOV.B EDE,TONI
	ADD #235h,&MEM	ADD.B #35h,&MEM
	PUSH R5	PUSH.B R5
	SWPB R5	—



**Table 2. Address Mode Descriptions**

ADDRESS MODE	s	d	SYNTAX	EXAMPLE	OPERATION
Register	√	√	MOV Rs, Rd	MOV R10, R11	R10 → R11
Indexed	√	√	MOV X(Rn), Y(Rm)	MOV 2(R5), 6(R6)	M(2 + R5) → M(6 + R6)
Symbolic (PC relative)	√	√	MOV EDE, TONI		M(EDE) → M(TONI)
Absolute	√	√	MOV &MEM, &TCDAT		M(MEM) → M(TCDAT)
Indirect	√		MOV @Rn, Y(Rm)	MOV @R10, Tab(R6)	M(R10) → M(Tab + R6)
Indirect autoincrement	√		MOV @Rn+, RM	MOV @R10+, R11	M(R10) → R11, R10 + 2 → R10
Immediate	√		MOV #X, TONI	MOV #45, TONI	#45 → M(TONI)

NOTE: s = source    d = destination

Computed branches (BR) and subroutine call (CALL) instructions use the same addressing modes as the other instructions. These addressing modes provide *indirect* addressing, ideally suited for computed branches and calls. The full use of this programming capability permits a program structure different from conventional 8- and 16-bit controllers. For example, numerous routines can easily be designed to deal with pointers and stacks instead of using flag type programs for flow control.

### operation modes and interrupts

The MSP430 operating modes support various advanced requirements for ultra low-power and ultra-low energy consumption. This is achieved by the management of the operations during the different module operation modes and CPU states. The requirements are fully supported during interrupt event handling. An interrupt event awakens the system from each of the various operating modes and returns with the RETI instruction to the mode that was selected before the interrupt event. The clocks used are ACLK and MCLK. ACLK is the crystal frequency and MCLK, a multiple of ACLK, is used as the system clock.

The software can configure five operating modes:

- Active mode (AM). The CPU is enabled with different combinations of active peripheral modules.
- Low-power mode 0 (LPM0). The CPU is disabled, peripheral operation continues, ACLK and MCLK signals are active, and loop control for MCLK is active.
- Low-power mode 1 (LPM1). The CPU is disabled, peripheral operation continues, ACLK and MCLK signals are active, and loop control for MCLK is inactive.
- Low-power mode 2 (LPM2). The CPU is disabled, peripheral operation continues, ACLK signal is active, and MCLK and loop control for MCLK are inactive.
- Low-power mode 3 (LPM3). The CPU is disabled, peripheral operation continues, ACLK signal is active, MCLK and loop control for MCLK are inactive, and the dc generator for the digital controlled oscillator (DCO) (→MCLK generator) is switched off.
- Low-power mode 4 (LPM4). The CPU is disabled, peripheral operation continues, ACLK signal is inactive (crystal oscillator stopped), MCLK and loop control for MCLK are inactive, and the dc generator for the DCO is switched off.

The special function registers (SFR) include module-enable bits that stop or enable the operation of the specific peripheral module. All registers of the peripherals may be accessed if the operational function is stopped or enabled. However, some peripheral current-saving functions are accessed through the state of local register bits. An example is the enable/disable of the analog voltage generator in the LCD peripheral, which is turned on or off using one register bit.

# MSP430x31x MIXED SIGNAL MICROCONTROLLERS

SLAS165D – FEBRUARY 1998 – REVISED APRIL 2000

## operation modes and interrupts (continued)

The most general bits that influence current consumption and support fast turn-on from low power operating modes are located in the status register (SR). Four of these bits control the CPU and the system clock generator: SCG1, SCG0, OscOff, and CPUOff.

15	9	8	7						0
Reserved For Future Enhancements	V	SCG1	SCG0	OscOff	CPUOff	GIE	N	Z	C
rw-0	rw-0	rw-0	rw-0	rw-0	rw-0	rw-0	rw-0	rw-0	rw-0

## interrupt vector addresses

The interrupt vectors and the power-up starting address are located in the ROM with an address range of 0FFFFh-0FFE0h. The vector contains the 16-bit address of the appropriate interrupt handler instruction sequence.

INTERRUPT SOURCE	INTERRUPT FLAG	SYSTEM INTERRUPT	WORD ADDRESS	PRIORITY
Power-up, external reset, watchdog	WDTIFG (see Note 1)	Reset	0FFFEh	15, highest
NMI, oscillator fault	NMIIFG (see Notes 1 and 3) OFIFG (see Notes 1 and 4)	Nonmaskable, (Non)maskable	0FFFCh	14
Dedicated I/O P0.0	P0.0IFG	Maskable	0FFFAh	13
Dedicated I/O P0.1	P0.1IFG	Maskable	0FFF8h	12
8-Bit Timer/Counter			0FFF6h	11
Watchdog Timer	WDTIFG	Maskable	0FFF4h	10
			0FFF2h	9
			0FFF0h	8
			0FFEEh	7
			0FFEC	6
Timer/Port	RC1FG, RC2FG, EN1FG (see Note 2)	Maskable	0FFEAh	5
			0FFE8h	4
			0FFE6h	3
			0FFE4h	2
Basic Timer1	BTIFG	Maskable	0FFE2h	1
I/O Port 0.2–7	P0.27IFG (see Note 1)	Maskable	0FFE0h	0, lowest

- NOTES: 1. Multiple source flags  
 2. Timer/port interrupt flags are located in the timer/port registers  
 3. Non maskable: neither the individual nor the general interrupt enable bit will disable an interrupt event.  
 4. (Non) maskable: the individual interrupt enable bit can disable an interrupt event, but the general interrupt enable bit cannot.



### special function registers

Most interrupt and module enable bits are collected into the lowest address space. Special function register bits that are not allocated to a functional purpose are not physically present in the device. Simple software access is provided with this arrangement.

#### interrupt enable 1 and 2

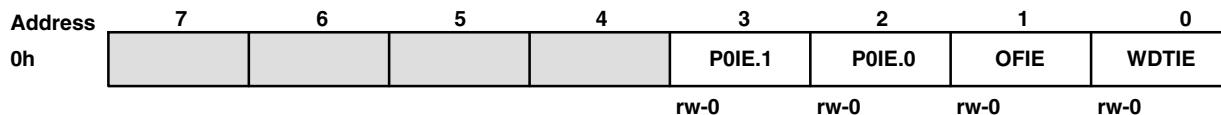

WDTIE: Watchdog Timer enable signal  
 OFIE: Oscillator fault enable signal  
 P0IE.0: Dedicated I/O P0.0  
 P0IE.1: P0.1 or 8-Bit Timer/Counter, RXD

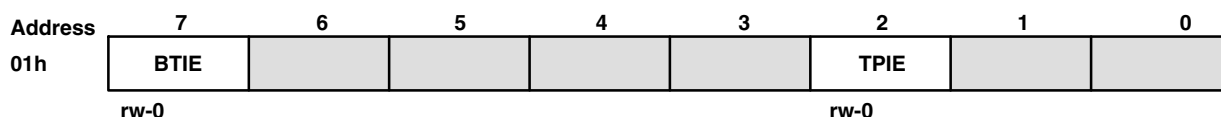

TPIE: Timer/Port enable signal  
 BTIE: Basic Timer1 enable signal

#### interrupt flag register 1 and 2

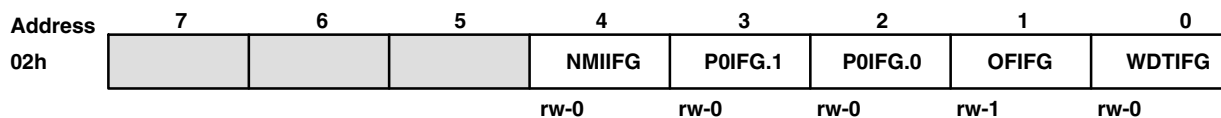

WDTIFG: Set on overflow or security key violation  
 OR  
 Reset on V<sub>CC</sub> power-on or reset condition at RST/NMI-pin  
 OFIFG: Flag set on oscillator fault  
 P0.0IFG: Dedicated I/O P0.0  
 P0.1IFG: P0.1 or 8-Bit Timer/Counter, RXD  
 NMIIFG: Signal at RST/NMI-pin



BTIFG: Basic Timer1 flag

#### module enable register 1 and 2

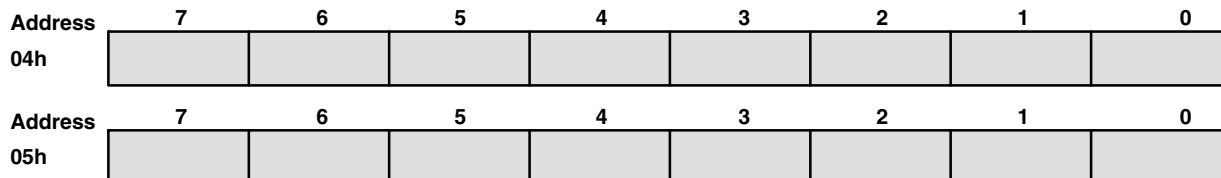

**Legend**    rw:            Bit can be read and written.  
               rw-0:         Bit can be read and written. It is reset by PUC  
                      SFR bit is not present in device.

# MSP430x31x MIXED SIGNAL MICROCONTROLLERS

SLAS165D – FEBRUARY 1998 – REVISED APRIL 2000

## memory organization

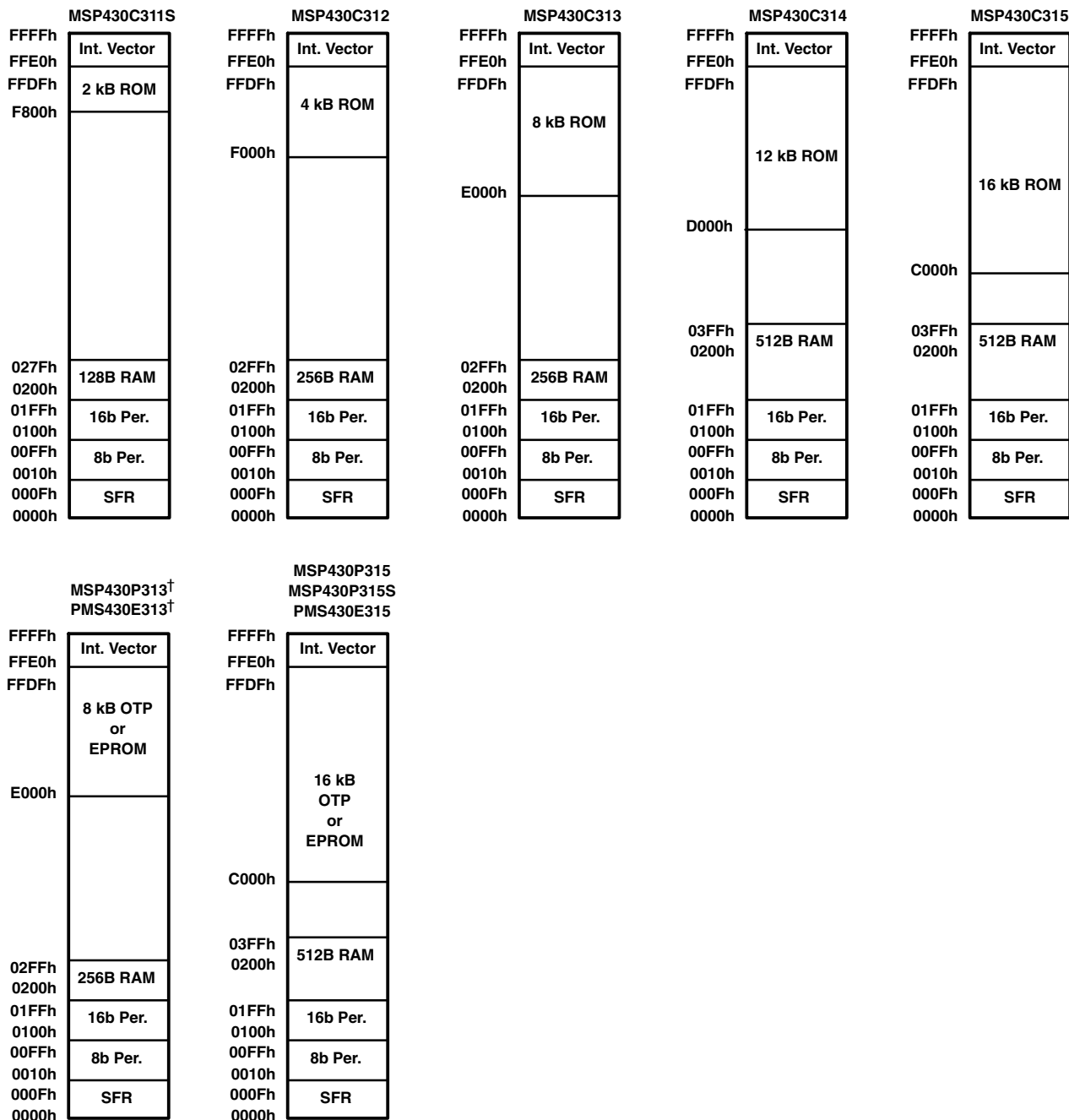

† MSP430P313/E313 not recommended for new designs – replaced by MSP430P315/E315.



## peripherals

Peripherals connected to the CPU through a data, address, and control busses can be handled easily with instructions for memory manipulation.

## oscillator and system clock

Two clocks are used in the system: the system (master) clock (MCLK) and the auxiliary clock (ACLK). The MCLK is a multiple of the ACLK. The ACLK runs with the crystal oscillator frequency. The special design of the oscillator supports the feature of low current consumption and the use of a 32 768 Hz crystal. The crystal is connected across two terminals without requiring any other external components.

The oscillator starts after applying VCC, due to a reset of the control bit (OscOff) in the status register (SR). It can be stopped by setting the OscOff bit to a 1. The enabled clock signals ACLK, ACLK/2, ACLK/4, or MCLK are accessible for use by external devices at output terminal XBUF.

The controller system clock has to operate with different requirements according to the application and system conditions. Requirements include:

- High frequency in order to react quickly to system hardware requests or events
- Low frequency in order to minimize current consumption, EMI, etc.
- Stable frequency for timer applications e.g. real-time clock (RTC)
- Enable start-stop operation with a minimum delay

These requirements cannot all be met with fast frequency high-Q crystals or with RC-type low-Q oscillators. The compromise selected for the MSP430 uses a low-crystal frequency, which is multiplied to achieve the desired nominal operating range:

$$f_{(\text{system})} = (N+1) \times f_{(\text{crystal})}$$

The crystal frequency multiplication is achieved with a frequency locked loop (FLL) technique. The factor N is set to 31 after a power-up clear condition. The FLL technique, in combination with a digital controlled oscillator (DCO), provides immediate start-up capability together with long-term crystal stability. The frequency variation of the DCO with the FLL inactive is typically 330 ppm, which means that with a cycle time of 1  $\mu$ s, the maximum possible variation is 0.33 ns. For more precise timing, the FLL can be used. This forces longer cycle times if the previous cycle time was shorter than the selected one. This switching of cycle times makes it possible to meet the chosen system frequency over a long period of time.

The start-up operation of the system clock depends on the previous machine state. During a power-up clear (PUC), the DCO is reset to its lowest possible frequency. The control logic starts operation immediately after removal of the PUC condition. Correct operation of the FLL control logic requires the presence of a stable crystal oscillator.



# MSP430x31x MIXED SIGNAL MICROCONTROLLERS

SLAS165D – FEBRUARY 1998 – REVISED APRIL 2000

---

## peripherals (continued)

### digital I/O

There is one eight-bit I/O port, Port0, that is implemented (MSP430C311S and MSP430P315S have six bits available on external pins). Six control registers give maximum digital input/output flexibility to the application:

- All individual I/O bits are programmable independently.
- Any combination of input, output, and interrupt conditions is possible.
- Interrupt processing of external events is fully implemented for all eight bits of port P0.
- Provides read/write access to all registers with all instructions

The six registers are:

- |                         |        |  |
|-------------------------|--------|--|
| • Input register        | 8 bits | contains information at the pins                     |
| • Output register       | 8 bits | contains output information                          |
| • Direction register    | 8 bits | controls direction                                   |
| • Interrupt flags       | 6 bits | indicates if interrupt(s) are pending                |
| • Interrupt edge select | 8 bits | contains input signal change necessary for interrupt |
| • Interrupt enable      | 6 bits | contains interrupt enable bits                       |

All these registers contain eight bits except for the interrupt flag register and the interrupt enable register. The two least significant bits (LSBs) of the interrupt flag and interrupt enable registers are located in the special functions register (SFR). Three interrupt vectors are implemented, one for Port0.0, one for Port0.1, and one commonly used for any interrupt event on Port0.2 to Port0.7. The Port0.1 and Port0.2 pin function is shared with the 8-bit timer/counter.

### LCD drive

Liquid crystal displays (LCDs) for static, 2-, 3-, and 4-MUX operations can be driven directly. The controller LCD logic operation is defined by software using memory-bit manipulation. LCD memory is part of the LCD module and not part of the data memory. Eight mode and control bits define the operation and current consumption of the LCD drive. The information for the individual digits can be easily obtained using table programming techniques combined with the correct addressing mode. The segment information is stored in LCD memory using instructions for memory manipulation.

The drive capability is mainly defined by the external resistor divider that supports the analog levels for 2-, 3-, and 4-MUX operation. Groups of the LCD segment lines can be selected for digital output signals. The MSP430x31x has four common signals and 23 segment lines. The MSP430C311S and MSP430P315S have four common lines and 16 segment lines.

### Timer/Port

The Timer/Port module has two 8-bit counters, an input that triggers one counter, and six digital outputs in the MSP430x31x (MSP430C311S, MSP430C315S have five digital outputs available on external pins) with high-impedance state capability. Both counters have an independent clock-selector for selecting an external signal or one of the internal clocks (ACLK or MCLK). One counter has an extended control capability to halt, count continuously, or gate the counter by selecting one of two external signals. This gate signal sets the interrupt flag, if an external signal is selected, and the gate stops the counter.

Both timers can be read from and written to by software. The two 8-bit counters can be cascaded to a 16-bit counter. A common interrupt vector is implemented. The interrupt flag can be set from three events in the 8-bit counter mode (gate signal, overflow from the counters) or from two events in the 16-bit counter mode (gate signal, overflow from the MSB of the cascaded counter).



POST OFFICE BOX 655303 • DALLAS, TEXAS 75265  
POST OFFICE BOX 1443 • HOUSTON, TEXAS 77251-1443

## peripherals (continued)

### slope A/D conversion

Slope A/D conversion is accomplished with the timer/port module using external resistor(s) for reference ( $R_{ref}$ ), external resistor(s) to the measured ( $R_{meas}$ ), and an external capacitor. The external components are driven by software in such a way that the internal counter measures the time that is needed to charge or discharge the capacitor. The reference resistor's ( $R_{ref}$ ) charge or discharge time is represented by  $N_{ref}$  counts. The unknown resistors ( $R_{meas}$ ) charge or discharge time is represented by  $N_{meas}$  counts. The unknown resistor's value ( $R_{meas}$ ) is the value of  $R_{ref}$  multiplied by the relative number of counts ( $N_{meas}/N_{ref}$ ). This value determines resistive sensor values that correspond to the physical data, for example temperature, when an NTC or PTC resistor is used.

### Basic Timer1

The Basic Timer1 (BT1) divides the frequency of MCLK or ACLK, as selected with the SSEL bit, to provide low frequency control signals. This is done within the system by one central divider, the basic timer1, to support low current applications. The BTCTL control register contains the flags which controls or selects the different operational functions. When the supply voltage is applied or when a reset of the device ( $\overline{RST}/NMI$  pin), a watchdog overflow, or a watchdog security key violation occurs, all bits in the register hold undefined or unchanged status. The user software usually configures the operational conditions on the BT1 during initialization.

The Basic Timer1 has two 8 bit timers which can be cascaded to a 16 bit timer. Both timers can be read and written by software. Two bits in the SFR address range handle the system control interaction according to the function implemented in the Basic Timer1. These two bits are the Basic Timer1 interrupt flag (BTIFG) and the basic timer interrupt enable (BTIE) bit.

### Watchdog Timer

The primary function of the Watchdog Timer (WDT) module is to perform a controlled system restart after a software problem has occurred. If the selected time interval expires, a system reset is generated. If this watchdog function is not needed in an application, the module can work as an interval timer, which generates an interrupt after the selected time interval.

The Watchdog Timer counter (WDTCNT) is a 15/16-bit up-counter which is not directly accessible by software. The WDTCNT is controlled using the Watchdog Timer control register (WDTCTL), which is a 16-bit read/write register. Writing to WDTCTL, in both operating modes (watchdog or timer) is only possible by using the correct password in the high-byte. The low-byte stores data written to the WDTCTL. The high-byte password is 05Ah. If any value other than 05Ah is written to the high-byte of the WDTCTL, a system reset PUC is generated. When the password is read its value is 069h. This minimizes accidental write operations to the WDTCTL register. In addition to the Watchdog Timer control bits, there are two bits included in the WDTCTL which configure the NMI pin.

### 8-Bit Timer/Counter

The 8-bit interval timer supports three major functions for the application:

- Serial communication or data exchange
- Pulse counting or pulse accumulation
- Timer

The 8-bit Timer/Counter peripheral includes the following major blocks: an 8-bit up-counter with preload-register, an 8-bit control register, an input clock selector, an edge detection (e.g. start bit detection for asynchronous protocols), and an input and output data latch, triggered by the carry-out-signal from the 8-bit counter.

The 8-bit counter counts up with an input clock, which is selected by two control bits from the control register. The four possible clock sources are MCLK, ACLK, the external signal from terminal P0.1, and the signal from the logical AND of MCLK and terminal P0.1.



# MSP430x31x MIXED SIGNAL MICROCONTROLLERS

SLAS165D – FEBRUARY 1998 – REVISED APRIL 2000

## 8-Bit Timer/Counter (continued)

Two counter inputs (load, enable) control the counter operation. The load input controls load operations. A write-access to the counter results in loading the content of the preload-register into the counter. The software writes or reads the preload-register with all instructions. The preload-register acts as a buffer and can be written immediately after the load of the counter is completed. The enable input enables the count operation. When the enable signal is set to high, the counter will count up each time a positive clock edge is applied to the clock input of the counter.

Serial protocols, like UART protocol, need start-bit edge-detection to determine, at the receiver, the start of a data transmission. When this function is activated, the counter starts counting after start-bit condition is detected. The first signal level is sampled into the RXD input data-latch after completing the first timing interval, which is programmed into the counter. Two latches used for input and output data (RXD\_FF and TXD\_FF) are clocked by the counter after the programmed timing interval has elapsed.

## UART

The serial communication is realized by using software and the 8-bit timer/counter hardware. The hardware supports the output of the serial data stream, bit-by-bit, with the timing determined by the counter. The software/hardware interface connects the mixed signal controller to external devices, systems, or networks.

## peripheral file map

PERIPHERALS WITH WORD ACCESS				
Watchdog	Watchdog Timer control	WDTCTL	0120h	
PERIPHERALS WITH BYTE ACCESS				
EPROM	EPROM control	EPCTL	054h	
Crystal buffer	Crystal buffer control	CBCTL	053h	
System clock	SCG frequency control	SCFQCTL	052h	
	SCG frequency integrator	SCFI1	051h	
	SCG frequency integrator	SCFI0	050h	
Timer /Port	Timer/Port enable	TPE	04Fh	
	Timer/Port data	TPD	04Eh	
	Timer/Port counter2	TPCNT2	04Dh	
	Timer/Port counter1	TPCNT1	04Ch	
	Timer/Port control	TPCTL	04Bh	
8-Bit Timer/Counter	8-Bit Timer/Counter data	TCDAT	044h	
	8-Bit Timer/Counter preload	TCPLD	043h	
	8-Bit Timer/Counter control	TCCTL	042h	
Basic Timer1	Basic Timer/Counter2	BTCNT2	047h	
	Basic Timer/Counter1	BTCNT1	046h	
	Basic Timer control	BTCTL	040h	
LCD	LCD memory 15	LCDM15	03Fh	
	:			
	LCD memory1	LCDM1	031h	
LCD	LCD control & mode	LCDCTL	030h	
	Port P0	Port P0 interrupt enable	P0IE	015h
		Port P0 interrupt edge select	P0IES	014h
Port P0 interrupt flag		P0IFG	013h	
Port P0 direction		P0DIR	012h	
Port P0 output		P0OUT	011h	
Port P0 input		P0IN	010h	
Special function		SFR interrupt flag2	IFG2	003h
	SFR interrupt flag1	IFG1	002h	
	SFR interrupt enable2	IE2	001h	
	SFR interrupt enable1	IE1	000h	



**absolute maximum ratings†**

Voltage applied at $V_{CC}$ to $V_{SS}$ .....	–0.3 V to 6 V
Voltage applied to any pin (referenced to $V_{SS}$ ) .....	–0.3 V to $V_{CC} + 0.3$ V
Diode current at any device terminal .....	±2 mA
Storage temperature, $T_{stg}$ (unprogrammed device) .....	–55°C to 150°C
Storage temperature, $T_{stg}$ (programmed device) .....	–40°C to 85°C

† Stresses beyond those listed under “absolute maximum ratings” may cause permanent damage to the device. These are stress ratings only, and functional operation of the device at these or any other conditions beyond those indicated under “recommended operating conditions” is not implied. Exposure to absolute-maximum-rated conditions for extended periods may affect device reliability.

NOTE: All voltages referenced to  $V_{SS}$ .

**recommended operating conditions**

		MIN	NOM	MAX	UNIT
Supply voltage, $V_{CC}$	MSP430Cxxx	2.5		5.5	V
	MSP430P313‡, PMS430E313‡	2.7		5.5	
	MSP430P315, PMS430E315	2.7		5.5	
Supply voltage during programming, $V_{CC}$	MSP430P313	2.7		5.5	V
	MSP430P315	4.5		5.5	V
Supply voltage, $V_{SS}$			0		V
Operating free-air temperature range, $T_A$	MSP430C31x	–40		85	°C
	MSP430P31x				
	PMS430E31x		25		
XTAL frequency, $f_{(XTAL)}$			32 768		Hz
Processor frequency $f_{(system)}$ (signal MCLK) $f_{system}$	$V_{CC} = 3$ V	DC		2.2	MHz
	$V_{CC} = 5$ V	DC		3.3	
Low-level input voltage, $V_{IL}$ (excluding $X_{in}$ , $X_{out}$ )	$V_{CC} = 3$ V/5 V		$V_{SS}$	$V_{SS} + 0.8$	V
High-level input voltage, $V_{IH}$ (excluding $X_{in}$ , $X_{out}$ )			$0.7 \times V_{CC}$	$V_{CC}$	
Low-level input voltage, $V_{IL}(X_{in}, X_{out})$			$V_{SS}$	$0.2 \times V_{CC}$	V
High-level input voltage, $V_{IH}(X_{in}, X_{out})$			$0.8 \times V_{CC}$	$V_{CC}$	

‡ MSP430P313/E313 not recommended for new designs – replaced by MSP430P315/E315.

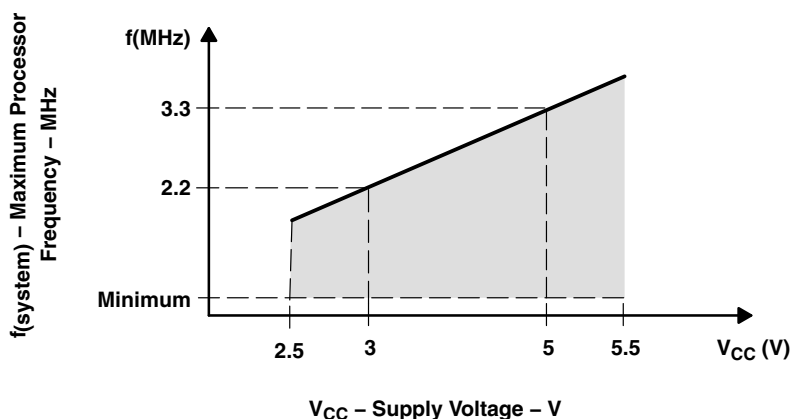

NOTE: Minimum processor frequency is defined by system clock.

**Figure 1. Processor Frequency vs Supply Voltage, C Versions**



# MSP430x31x MIXED SIGNAL MICROCONTROLLERS

SLAS165D – FEBRUARY 1998 – REVISED APRIL 2000

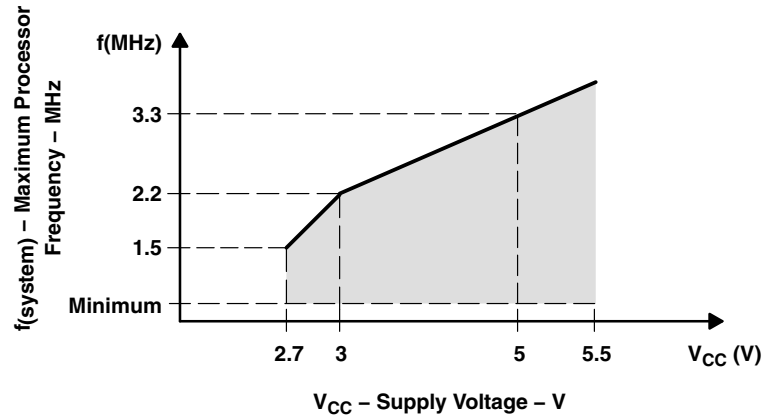

NOTE: Minimum processor frequency is defined by system clock.

Figure 2. Processor Frequency vs Supply Voltage, P/E Versions

electrical characteristics over recommended operating free-air temperature range (unless otherwise noted)

supply current (into  $V_{CC}$ ) excluding external current ( $f_{\text{system}} = 1 \text{ MHz}$ )

PARAMETER		TEST CONDITIONS		MIN	NOM	MAX	UNIT	
$I_{(AM)}$	Active mode	C31x	$T_A = -40^\circ\text{C} + 85^\circ\text{C}$	$V_{CC} = 3 \text{ V}$	400	500	$\mu\text{A}$	
				$V_{CC} = 5 \text{ V}$	730	850		
	P313†	$T_A = -40^\circ\text{C} + 85^\circ\text{C}$	$V_{CC} = 3 \text{ V}$	2100	2700			
			$V_{CC} = 5 \text{ V}$	7000	8600			
	P315(S)	$T_A = -40^\circ\text{C} + 85^\circ\text{C}$	$V_{CC} = 3 \text{ V}$	490	550			
			$V_{CC} = 5 \text{ V}$	960	1050			
$I_{(CPUoff)}$	Low-power mode, (LPM0,1)	C31x	$T_A = -40^\circ\text{C} + 85^\circ\text{C}$	$V_{CC} = 3 \text{ V}$	50	70	$\mu\text{A}$	
				$V_{CC} = 5 \text{ V}$	100	130		
	P313†	$T_A = -40^\circ\text{C} + 85^\circ\text{C}$	$V_{CC} = 3 \text{ V}$	70	85			
			$V_{CC} = 5 \text{ V}$	150	170			
	P315(S)	$T_A = -40^\circ\text{C} + 85^\circ\text{C}$	$V_{CC} = 3 \text{ V}$	50	70			
			$V_{CC} = 5 \text{ V}$	100	130			
$I_{(LPM2)}$	Low-power mode, (LPM2)		$T_A = -40^\circ\text{C} + 85^\circ\text{C}$	$V_{CC} = 3 \text{ V}$	6	12	$\mu\text{A}$	
				$V_{CC} = 5 \text{ V}$	13	25		
$I_{(LPM3)}$	Low-power mode, (LPM3)	$T_A = -40^\circ\text{C}$	$V_{CC} = 3 \text{ V}$		1.5	2.4	$\mu\text{A}$	
				$T_A = 25^\circ\text{C}$		1.3		2
				$T_A = 85^\circ\text{C}$		1.6		2.8
		$T_A = -40^\circ\text{C}$	$V_{CC} = 5 \text{ V}$		5.2	7		
				$T_A = 25^\circ\text{C}$		4.2		6
				$T_A = 85^\circ\text{C}$		4.8		5.4
$I_{(LPM4)}$	Low-power mode, (LPM4)	$T_A = -40^\circ\text{C}$	$V_{CC} = 3 \text{ V}/5 \text{ V}$		0.1	0.8	$\mu\text{A}$	
		$T_A = 25^\circ\text{C}$			0.1	0.8		
		$T_A = 85^\circ\text{C}$			0.4	1.3		

† MSP430P313/E313 not recommended for new designs – replaced by MSP430P315/E315.

NOTE: All inputs are tied to 0 V or  $V_{CC}$ . Outputs do not source or sink any current. The current consumption in LPM2 and LPM3 are measured with active basic timer (ACLK selected) and LCD module. ( $f_{LCD} = 1024 \text{ Hz}$ , 4 mux)



POST OFFICE BOX 655303 • DALLAS, TEXAS 75265  
POST OFFICE BOX 1443 • HOUSTON, TEXAS 77251-1443

**electrical characteristics over recommended operating free-air temperature range (unless otherwise noted) (continued)**

**current consumption of active mode versus system frequency, C versions only**

$$I_{AM} = I_{AM}[1 \text{ MHz}] \times f_{\text{system}} [\text{MHz}]$$

**current consumption of active mode versus supply voltage, C versions only**

$$I_{AM} = I_{AM}[3 \text{ V}] + 200 \mu\text{A/V} \times (V_{CC} - 3 \text{ V})$$

**schmitt-trigger inputs port 0, Timer/Port, CIN, TP0.5**

PARAMETER		TEST CONDITIONS	MIN	NOM	MAX	UNIT
V <sub>IT+</sub>	Positive-going input threshold voltage	V <sub>CC</sub> = 3 V	1.2		2.1	V
		V <sub>CC</sub> = 5 V	2.3		3.4	
V <sub>IT-</sub>	Negative-going input threshold voltage	V <sub>CC</sub> = 3 V	0.5		1.35	V
		V <sub>CC</sub> = 5 V	1.4		2.3	
V <sub>hys</sub>	Input hysteresis (V <sub>IT+</sub> - V <sub>IT-</sub> )	V <sub>CC</sub> = 3 V	0.3		1	V
		V <sub>CC</sub> = 5 V	0.6		1.4	

**standard inputs TCK, TMS, TDI, RST/NMI**

PARAMETER		TEST CONDITIONS	MIN	NOM	MAX	UNIT
V <sub>IL</sub>	Low-level input voltage	V <sub>CC</sub> = 3 V/5 V	V <sub>SS</sub>		V <sub>SS</sub> +0.8	V
V <sub>IH</sub>	High-level input voltage		0.7V <sub>CC</sub>		V <sub>CC</sub>	

**outputs port 0, P0.x, Timer/Port, TP0.0 – 5, LCD: S2/O2 to S26/O26 XBUF:XBUF, JTAG:TDO**

PARAMETER		TEST CONDITIONS	MIN	NOM	MAX	UNIT
V <sub>OH</sub>	High-level output voltage	I <sub>OH</sub> = -1.2 mA, V <sub>CC</sub> = 3 V, See Note 5	V <sub>CC</sub> -0.4		V <sub>CC</sub>	V
		I <sub>OH</sub> = -3.5 mA, V <sub>CC</sub> = 3 V, See Note 6	V <sub>CC</sub> -1		V <sub>CC</sub>	
		I <sub>OH</sub> = -1.5 mA, V <sub>CC</sub> = 5 V, See Note 5	V <sub>CC</sub> -0.4		V <sub>CC</sub>	
		I <sub>OH</sub> = -4.5 mA, V <sub>CC</sub> = 5 V, See Note 6	V <sub>CC</sub> -1		V <sub>CC</sub>	
V <sub>OL</sub>	Low-level output voltage	I <sub>OL</sub> = 1.2 mA, V <sub>CC</sub> = 3 V, See Note 5	V <sub>SS</sub>		V <sub>SS</sub> +0.4	V
		I <sub>OL</sub> = 3.5 mA, V <sub>CC</sub> = 3 V, See Note 6	V <sub>SS</sub>		V <sub>SS</sub> +1	
		I <sub>OL</sub> = 1.5 mA, V <sub>CC</sub> = 5 V, See Note 5	V <sub>SS</sub>		V <sub>SS</sub> +0.4	
		I <sub>OL</sub> = 4.5 mA, V <sub>CC</sub> = 5 V, See Note 6	V <sub>SS</sub>		V <sub>SS</sub> +1	

- NOTES: 5. The maximum total current, I<sub>OH</sub>max and I<sub>OL</sub>max, for all outputs combined, should not exceed ±9.6 mA to hold the maximum voltage drop specified.  
6. The maximum total current, I<sub>OH</sub>max and I<sub>OL</sub>max, for all outputs combined, should not exceed ±20 mA to hold the maximum voltage drop specified.

**leakage current (see Note 7)**

PARAMETER		TEST CONDITIONS	MIN	NOM	MAX	UNIT
I <sub>lkg</sub> (TP)	High-impedance leakage current, timer/port	Timer/port: V <sub>TP0.x</sub> , V <sub>CC</sub> = 3 V/5 V, CIN = V <sub>SS</sub> , V <sub>CC</sub> , (see Note 8)			±50	nA
I <sub>lkg</sub> (S27)	High-impedance leakage current, S27	V <sub>S27</sub> = V <sub>SS</sub> to V <sub>CC</sub> , V <sub>CC</sub> = 3 V/5 V			±50	nA
I <sub>lkg</sub> (P0x)	Leakage current, port 0	Port P0: P0.x, 0 ≤ x ≤ 7, V <sub>CC</sub> = 3 V/5 V, (see Note 9)			±50	nA

- NOTES: 7. The leakage current is measured with V<sub>SS</sub> or V<sub>CC</sub> applied to the corresponding pin(s), unless otherwise noted.  
8. All timer/port pins TP0.0 to TP0.5 are Hi-Z. Pins CIN and TP.0 to TP0.5 are connected together during leakage current measurement. In the leakage measurement the input CIN is included. The input voltage is V<sub>SS</sub> or V<sub>CC</sub>.  
9. The port pin must be selected for input and there must be no optional pullup or pulldown resistor.



# MSP430x31x MIXED SIGNAL MICROCONTROLLERS

SLAS165D – FEBRUARY 1998 – REVISED APRIL 2000

## electrical characteristics over recommended operating free-air temperature range (unless otherwise noted) (continued)

### optional resistors, individually programmable with ROM code, P0.x, (see Note 10)

PARAMETER		TEST CONDITIONS	MIN	NOM	MAX	UNIT
R <sub>(opt1)</sub>	Resistors, individually programmable with ROM code, all port pins, values applicable for pulldown and pullup	V <sub>CC</sub> = 3 V/5 V	2.1	4.1	6.2	kΩ
R <sub>(opt2)</sub>		V <sub>CC</sub> = 3 V/5 V	3.1	6.2	9.3	kΩ
R <sub>(opt3)</sub>		V <sub>CC</sub> = 3 V/5 V	6	12	18	kΩ
R <sub>(opt4)</sub>		V <sub>CC</sub> = 3 V/5 V	10	19	29	kΩ
R <sub>(opt5)</sub>		V <sub>CC</sub> = 3 V/5 V	19	37	56	kΩ
R <sub>(opt6)</sub>		V <sub>CC</sub> = 3 V/5 V	38	75	113	kΩ
R <sub>(opt7)</sub>		V <sub>CC</sub> = 3 V/5 V	56	112	168	kΩ
R <sub>(opt8)</sub>		V <sub>CC</sub> = 3 V/5 V	94	187	281	kΩ
R <sub>(opt9)</sub>		V <sub>CC</sub> = 3 V/5 V	131	261	392	kΩ
R <sub>(opt10)</sub>		V <sub>CC</sub> = 3 V/5 V	167	337	506	kΩ

NOTE 10: Optional resistors R<sub>optx</sub> for pull-down or pull-up are not programmed in standard OTP/EEPROM devices P/E313 (MSP430P313/E313) not recommended for new designs – replaced by MSP430P315/E315) and P/E315(s)

### inputs P0.x, CIN, TP.5; output XBUF

	PARAMETER	TEST CONDITIONS	VCC	MIN	NOM	MAX	UNIT
t <sub>(int)</sub>	External interrupt timing	Port P0 External trigger signal for the interrupt flag, (see Notes 11 and 12)	3 V/5 V	1.5			cycle
f <sub>(IN)</sub>	Input frequency	P0.x, CIN, TP.5	3 V/5 V	DC		f <sub>(system)</sub>	MHz
t <sub>(H)</sub> or t <sub>(L)</sub>	High level or low level time		3 V	225			ns
t <sub>(H)</sub> or t <sub>(L)</sub>			5 V	150			ns
f <sub>(XBUF)</sub>	Clock output frequency	XBUF, C <sub>L</sub> = 20 pF	3 V/5 V			f <sub>(system)</sub>	MHz
t <sub>(Xdc)</sub>	Duty cycle of clock output frequency	XBUF, C <sub>L</sub> = 20 pF, f <sub>(MCLK)</sub> = 1.1 MHz	3V/5V	40%			
		f <sub>(XBUF)</sub> = f <sub>(ACLK)</sub>	3V/5V	35%		60%	
		f <sub>(XBUF)</sub> = f <sub>(ACLK/n)</sub>	3V/5V		50%		65%

NOTES: 11. The external signal sets the interrupt flag every time t<sub>int</sub> is met. It may be set even with trigger signals shorter than t<sub>int</sub>. The conditions to set the flag must be met independently from this timing constraint. T<sub>int</sub> is defined in MCLK cycles.

12. The external interrupt signal cannot exceed the maximum input frequency (f<sub>(in)</sub>).

### crystal oscillator, Xin, Xout

	PARAMETER	TEST CONDITIONS	MIN	NOM	MAX	UNIT
C <sub>(Xin)</sub>	Integrated capacitance at input	V <sub>CC</sub> = 3 V/5 V		12		pF
C <sub>(Xout)</sub>	Integrated capacitance at output	V <sub>CC</sub> = 3 V/5 V		12		pF



electrical characteristics over recommended and operating free-air temperature range (unless otherwise noted) (continued)

PARAMETER		TEST CONDITIONS	MIN	NOM	MAX	UNIT
$f_{(NOM)}$	DCO	$N_{DCO} = 1A0h$ FN_4=FN_3=FN_2=0		1		MHz
$f_{(NOM)}$	$f_{DCO3}$	$N_{DCO} = 00\ 0110\ 0000$ FN_4=FN_3=FN_2=0	$V_{CC} = 3\ V$	0.15	0.6	MHz
			$V_{CC} = 5\ V$	0.18	0.62	
	$f_{DCO26}$	$N_{DCO} = 11\ 0100\ 0000$ FN_4=FN_3=FN_2=0	$V_{CC} = 3\ V$	1.25	4.7	
			$V_{CC} = 5\ V$	1.45	5.5	
$2xf_{(NOM)}$	$f_{DCO3}$	$N_{DCO} = 00\ 0110\ 0000$ FN_4=FN_3=0, FN_2=1	$V_{CC} = 3\ V$	0.36	1.05	MHz
			$V_{CC} = 5\ V$	0.39	1.2	
	$f_{DC26}$	$N_{DCO} = 11\ 0100\ 0000$ FN_4=FN_3=0, FN_2=1	$V_{CC} = 3\ V$	2.5	8.1	
			$V_{CC} = 5\ V$	3	9.9	
$3xf_{(NOM)}$	$f_{DCO3}$	$N_{DCO} = 00\ 0110\ 0000$ FN_4=0, FN_3=1, FN_2=X	$V_{CC} = 3\ V$	0.5	1.5	MHz
			$V_{CC} = 5\ V$	0.6	1.8	
	$f_{DCO26}$	$N_{DCO} = 11\ 0100\ 0000$ FN_4=0, FN_3=1, FN_2=X	$V_{CC} = 3\ V$	3.7	11	
			$V_{CC} = 5\ V$	4.5	13.8	
$4xf_{(NOM)}$	$f_{DCO3}$	$N_{DCO} = 00\ 0110\ 0000$ FN_4=1, FN_3=FN_2=X	$V_{CC} = 3\ V$	0.7	1.85	MHz
			$V_{CC} = 5\ V$	0.8	2.4	
	$f_{DCO26}$	$N_{DCO} = 11\ 0100\ 0000$ FN_4=1, FN_3=FN_2=X	$V_{CC} = 3\ V$	4.8	13.3	
			$V_{CC} = 5\ V$	6	17.7	
$N_{DCO}$		$f_{MCLK} = f_{NOM}$ FN_4=FN_3=FN_2=0	$V_{CC} = 3\ V/5\ V$	A0h	1A0h	340h
S		$f_{NDCO+1} = S \times f_{NDCO}$	$V_{CC} = 3\ V/5\ V$	1.07	1.13	

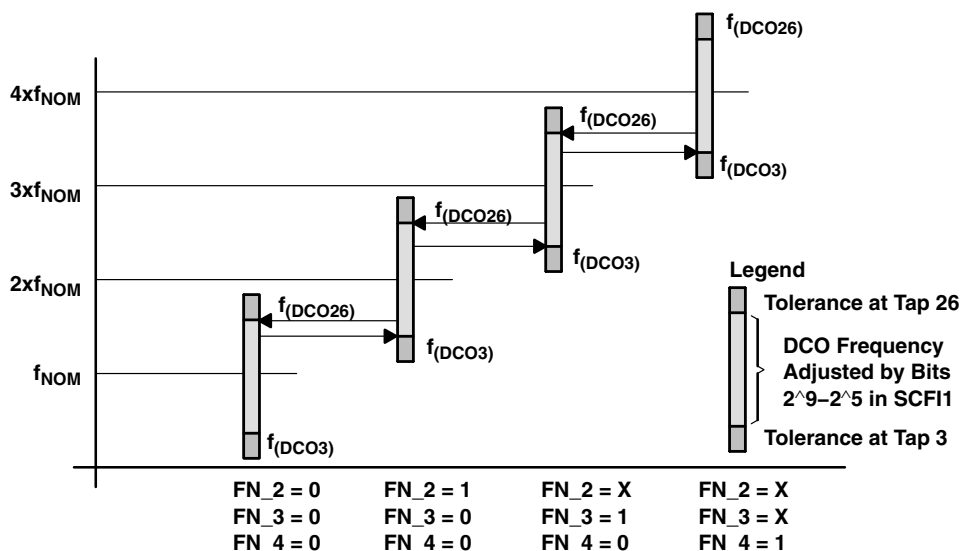

Figure 3

# MSP430x31x MIXED SIGNAL MICROCONTROLLERS

SLAS165D – FEBRUARY 1998 – REVISED APRIL 2000

electrical characteristics over recommended operating free-air temperature range (unless otherwise noted)

## LCD

PARAMETER		TEST CONDITIONS		MIN	NOM	MAX	UNIT	
V <sub>23</sub>	Analog voltage	Voltage at R23	V <sub>CC</sub> = 3 V/5 V		$(V_{CC}-V_{SS}) \times \frac{2}{3+V_{SS}}$		V	
V <sub>13</sub>		Voltage at R13	V <sub>CC</sub> = 3 V/5 V		$(V_{CC}-V_{SS}) \times \frac{1}{3+V_{SS}}$		V	
V <sub>O(HLCD)</sub>	Output 1 (HLCD)	I <sub>(HLCD)</sub> <= 10 nA	V <sub>CC</sub> = 3 V/5 V	V <sub>CC</sub> -0.125		V <sub>CC</sub>	V	
V <sub>O(LLCD)</sub>	Output 0 (LLCD)	I <sub>(LLCD)</sub> <= 10 nA		V <sub>SS</sub>		V <sub>SS</sub> +0.125		
I <sub>I(R13)</sub>	Input leakage (see Note 13)	R13 = V <sub>CC</sub> /3					±20	nA
I <sub>I(R23)</sub>		R23 = 2 V <sub>CC</sub> /3						
r <sub>o(R13) to S<sub>(XX)</sub></sub>	Output (SXX)	I <sub>(SXX)</sub> = -3 μA, V <sub>CC</sub> = 3 V/5 V				33	kΩ	
r <sub>o(R23) to S<sub>(XX)</sub></sub>								

NOTE 13: I<sub>I(Rxx)</sub> is measured with no load on the segment or common LCD I/O pins.

## comparator (Timer/Port)

PARAMETER		TEST CONDITIONS		MIN	NOM	MAX	UNIT
I <sub>(com)</sub>	Comparator (timer/port)	CPON = 1	V <sub>CC</sub> = 3 V		250	350	μA
			V <sub>CC</sub> = 5 V		450	600	
V <sub>ref(com)</sub>	Internal reference voltage at (-) terminal	CPON = 1	V <sub>CC</sub> = 3 V/5 V	0.230×V <sub>CC</sub>	0.25×V <sub>CC</sub>	0.260×V <sub>CC</sub>	V
V <sub>hys(com)</sub>	Input hysteresis (comparator)	CPON = 1	V <sub>CC</sub> = 3 V		5	37	mV
			V <sub>CC</sub> = 5 V		10	42	

## RAM

PARAMETER		TEST CONDITIONS		MIN	NOM	MAX	UNIT
V <sub>RAMh</sub>	CPU halted (see Note 14)			1.8			V

NOTE 14: This parameter defines the minimum supply voltage when the data in the program memory RAM remains unchanged. No program execution should happen during this supply voltage condition.

## PUC/POR

PARAMETER		TEST CONDITIONS		MIN	NOM	MAX	UNIT
t <sub>(POR_delay)</sub>	POR	V <sub>CC</sub> = 3 V/5 V		150	250		μs
V <sub>(POR)</sub>			T <sub>A</sub> = -40°C	1.5	2.4	V	
			T <sub>A</sub> = 25°C	1.2	2.1	V	
			T <sub>A</sub> = 85°C	0.9	1.8	V	
V <sub>(min)</sub>				0	0.4	V	
t <sub>(reset)</sub>	PUC/POR	Reset is accepted internally		2		μs	



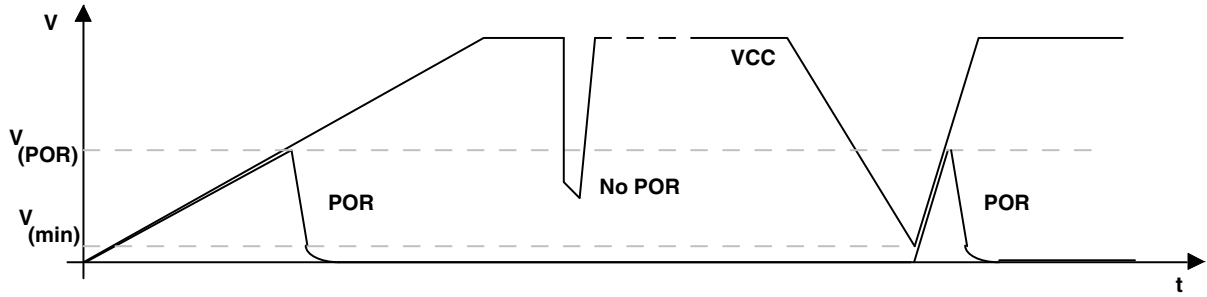

Figure 4. Power-On Reset (POR) vs Supply Voltage

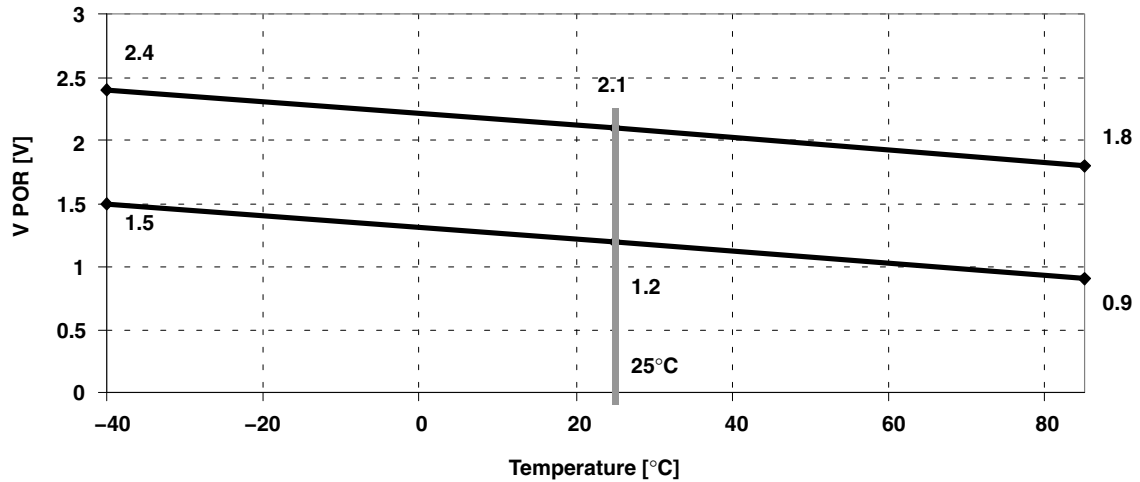

Figure 5.  $V_{(POR)}$  vs Temperature

wakeup from LPM3

PARAMETER		TEST CONDITIONS		MIN	NOM	MAX	UNIT
$t_{(LPM3)}$	Delay time	f = 1 MHz	$V_{CC} = 3 V$			6	$\mu s$
			$V_{CC} = 5 V$				
		f = 2 MHz	$V_{CC} = 3 V$				
			$V_{CC} = 5 V$				
		f = 3 MHz	$V_{CC} = 5 V$				

# MSP430x31x MIXED SIGNAL MICROCONTROLLERS

SLAS165D – FEBRUARY 1998 – REVISED APRIL 2000

**electrical characteristics over recommended operating free-air temperature range (unless otherwise noted)**

## JTAG, program memory

PARAMETER		TEST CONDITIONS	MIN	NOM	MAX	UNIT		
f <sub>(TCK)</sub>	JTAG/Test	TCK frequency	V <sub>CC</sub> = 3 V	DC	5	MHz		
			V <sub>CC</sub> = 5 V	DC	10			
R <sub>(TEST)</sub>		Pullup resistors on TMS, TCK, TDI (see Note 15)	V <sub>CC</sub> = 3 V/ 5 V	25	60	90	kΩ	
V <sub>(FB)</sub>	JTAG/Fuse (see Note 16)	Fuse blow voltage, C versions (see Note 15)	V <sub>CC</sub> = 3 V/ 5 V	5.5		6	V	
		Fuse blow voltage, E/P versions (see Note 17)	V <sub>CC</sub> = 3 V/ 5 V	11		12		
I <sub>(FB)</sub>		Supply current on TDI/VPP to blow fuse				100	mA	
t <sub>(FB)</sub>		Time to blow the fuse				1	ms	
V <sub>(PP)</sub>	P313, E313	Programming voltage, applied to TDI/VPP		11	11.5	13	V	
	P315(S), E315	Programming voltage, applied to TDI/VPP		12	12.5	13	V	
I <sub>(PP)</sub>		Current from programming voltage source				70	mA	
t <sub>(pps)</sub>	EPROM (E) and OTP(P) – versions only (see Note 18)	Programming time, single pulse		5			ms	
t <sub>(ppf)</sub>		Programming time, fast algorithm			100		μs	
P <sub>n</sub>		Pulses for successful programming		4		100		Pulses
t <sub>(erase)</sub>	EPROM (E)	Erase time wave length 2537 Å at 15 Ws/cm <sup>2</sup> (UV lamp of 12 mW/ cm <sup>2</sup> )		30			min	
		Write/erase cycles		1000				cycles
		Data retention T <sub>J</sub> < 55°C		10				years

- NOTES: 15. The TMS and TCK pullup resistors are implemented in all ROM(C) and EPROM(E) versions.  
 16. Once the JTAG fuse is blown no further access to the MSP430 JTAG/test feature is possible.  
 17. The voltage supply to blow the JTAG fuse is applied to TDI/VPP pin when fuse blowing is desired.  
 18. Refer to the Recommended Operating Conditions for the correct V<sub>CC</sub> during programing.



**TYPICAL CHARACTERISTICS**

**JTAG fuse check mode**

MSP430 devices that have the fuse on the TDI/VPP terminal have a fuse check mode that tests the continuity of the fuse the first time the JTAG port is accessed after a power-on reset (POR). When activated, a fuse check current,  $I_{TF}$ , of 1 mA at 3 V, 2.5 mA at 5 V can flow from the TDI/VPP pin to ground if the fuse is not burned. Care must be taken to avoid accidentally activating the fuse check mode and increasing overall system power consumption.

Activation of the fuse check mode occurs with the first negative edge on the TMS pin, after power up, or if the TMS is being held low after power-up. The second positive edge on the TMS pin deactivates the fuse check mode. After deactivation, the fuse check mode remains inactive until another POR occurs. After each POR the fuse check mode has the potential to be activated.

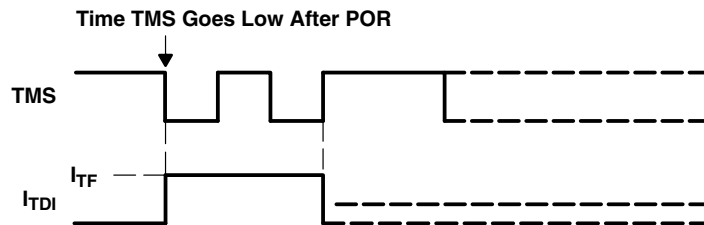

**Figure 6. Fuse Check Mode Current, MSP430P/E313,P/E315,C31x**

Care must be taken to avoid accidentally activating the fuse check mode, including guarding against EMI/ESD spikes that could cause signal edges on the TMS pin.

Configuration of TMS, TCK, TDI/VPP and TDO/TDI pins in applications.

	<b>C3xx</b>	<b>P/E3xx</b>
TDI	Open	68k, pulldown
TDO	Open	68k, pulldown
TMS	Open	Open
TCK	Open	Open

# MSP430x31x MIXED SIGNAL MICROCONTROLLERS

SLAS165D – FEBRUARY 1998 – REVISED APRIL 2000

## TYPICAL CHARACTERISTICS

DIGITAL CONTROLLED OSCILLATOR FREQUENCY  
vs  
OPERATING FREE-AIR TEMPERATURE

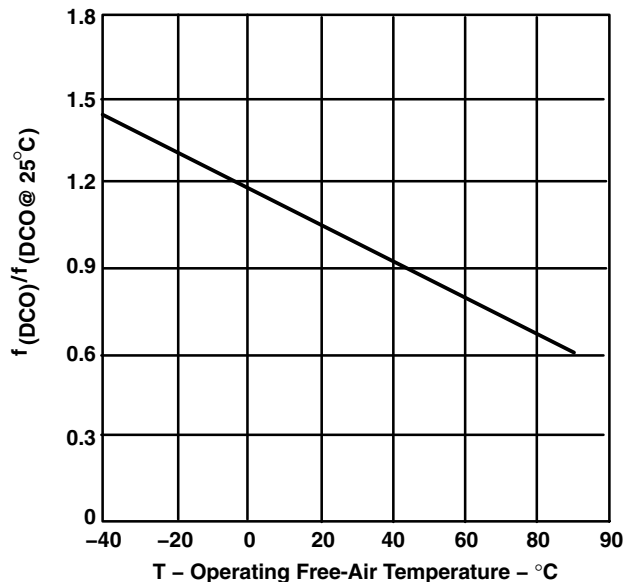

Figure 7

DIGITAL CONTROLLED OSCILLATOR FREQUENCY  
vs  
SUPPLY VOLTAGE

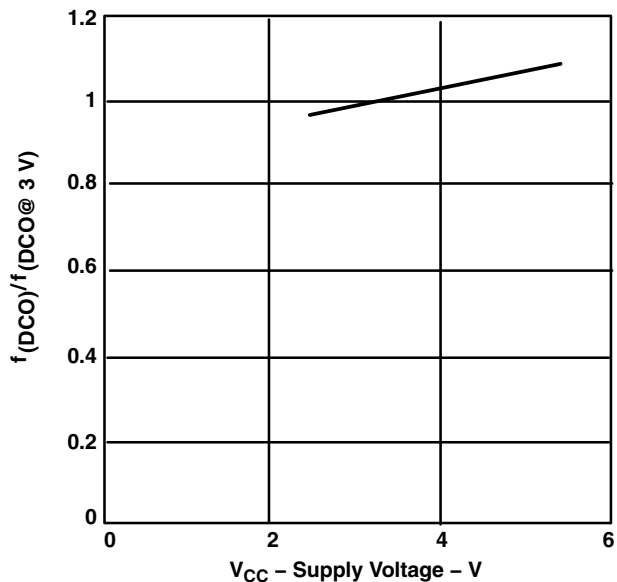
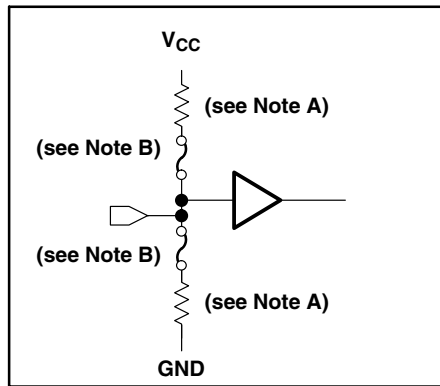

Figure 8

TYPICAL CHARACTERISTICS

typical input/output schematics



CMOS INPUT ( $\overline{\text{RST}}/\text{NMI}$ )

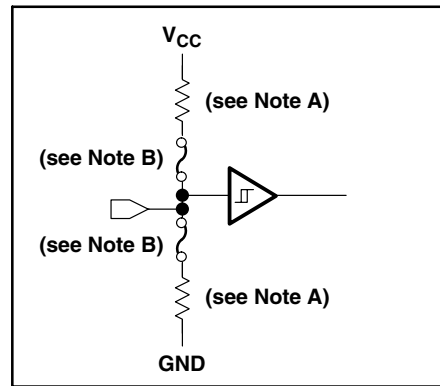

CMOS SCHMITT-TRIGGER INPUT (CIN)

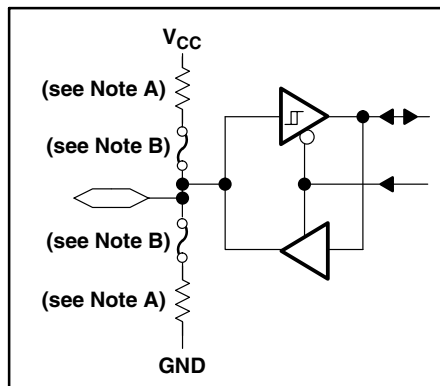

I/O WITH SCHMITT-TRIGGER INPUT (P0.x, TP0.5)

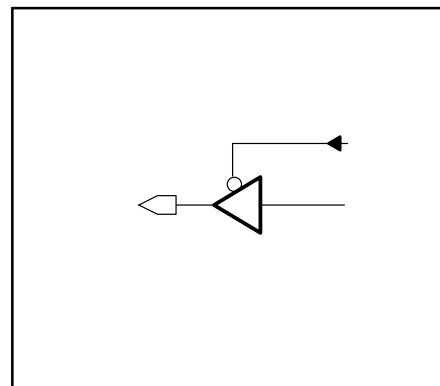

CMOS 3-STATE OUTPUT (TP0.0-4, XBUF)

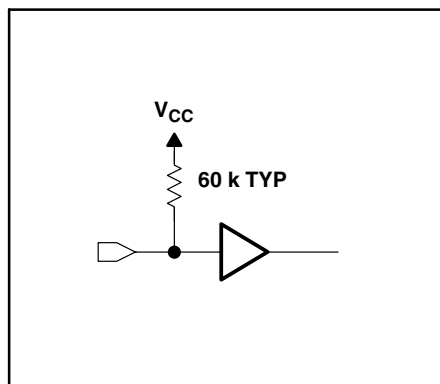

MSP430C31x: TMS, TCK  
MSP430P/E31x: TMS, TCK

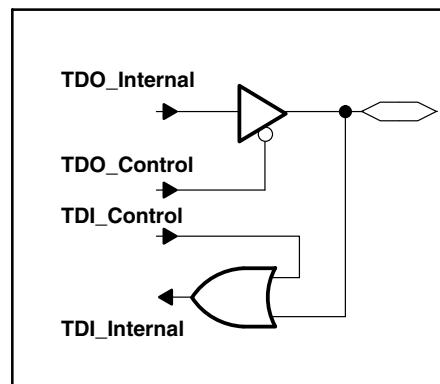

MSP430C31x: TDO/TDI  
MSP430P/E31x: TDO/TDI

NOTES: A. Optional selection of pull-up or pull-down resistors with ROM (masked) versions.  
B. Fuses for the optional pull-up and pull-down resistors can only be programmed at the factory.

**TYPICAL CHARACTERISTICS**

**typical input/output schematics**

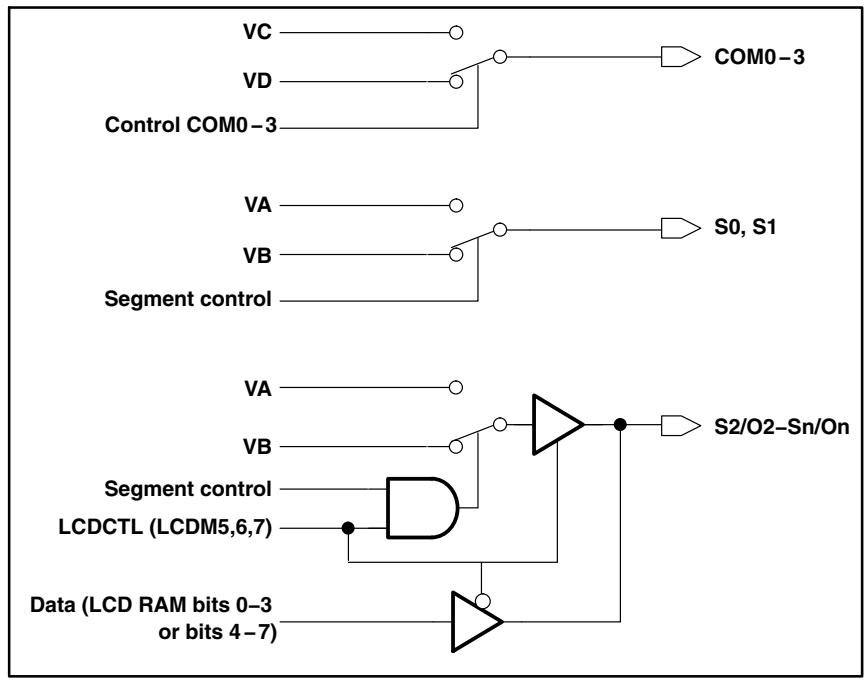

**LCD OUTPUT (COM0-4, Sn, Sn/On)**

NOTE: The signals VA, VB, VC, and VD come from the LCD module analog voltage generator.

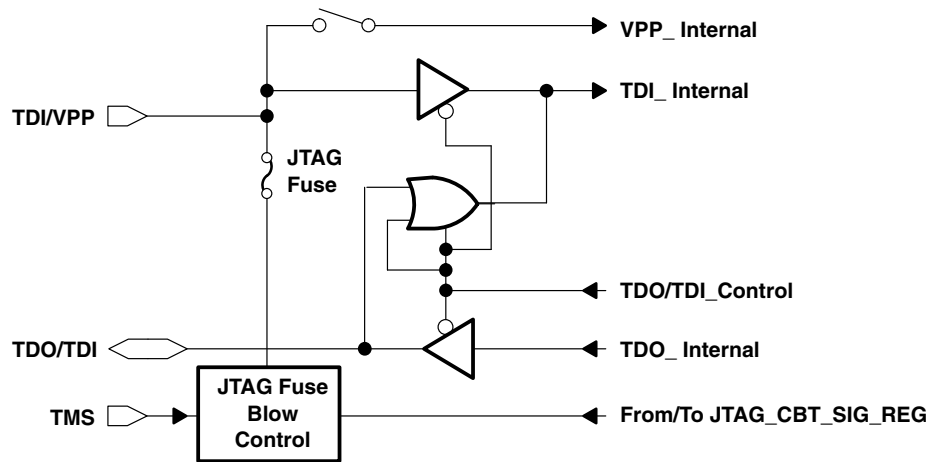

- NOTES:
- A. During programming activity and when blowing the JTAG enable fuse, the TDI/VPP terminal is used to apply the correct voltage source. The TDO/TDI terminal is used to apply the test input data for JTAG circuitry.
  - B. The TDI/VPP terminal of the 'P31x and 'E31x does not have an internal pullup resistor. An external pullup resistor is recommended to avoid a floating node, which could increase the current consumption of the device.
  - C. The TDO/TDI terminal is in a high-impedance state after POR. The 'P31x and 'E31x need a pullup or a pulldown resistor to avoid floating a node, which could increase the current consumption of the device.

**Figure 9. MSP430P313/E313/P315(S)/E315: TDI/VPP, TDO/TDI**

PMS430E313†, PMS430E315 (FZ package)

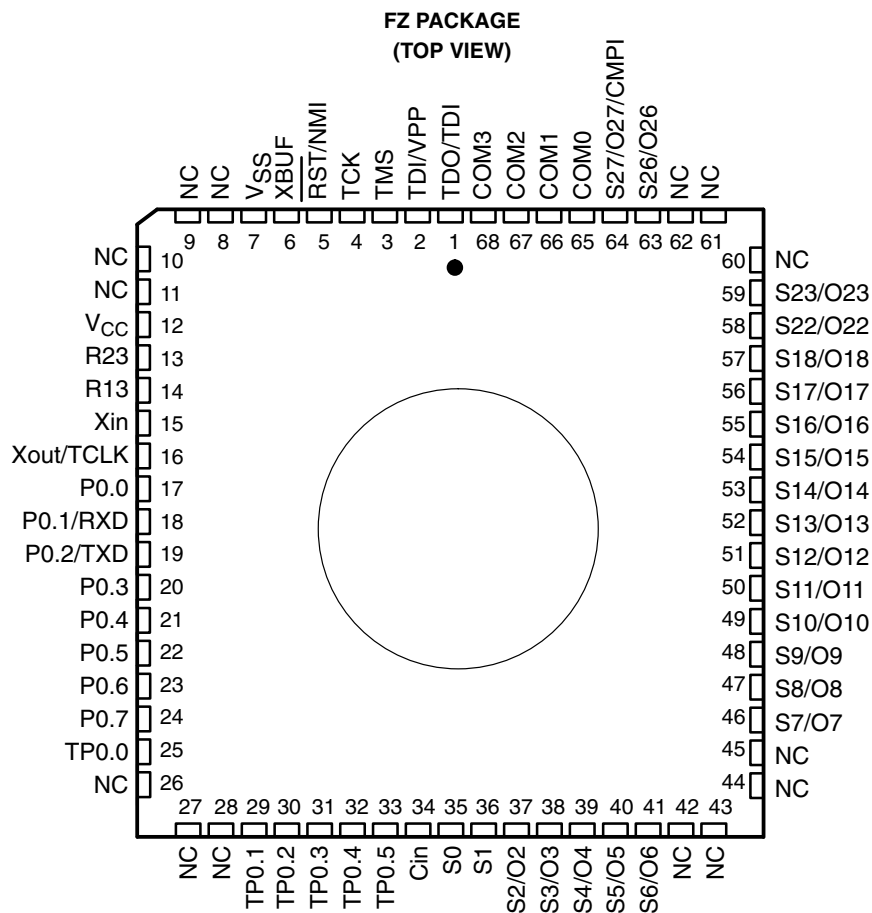

† MSP430P313/E313 not recommended for new designs – replaced by MSP430P315/E315.

# MSP430x31x MIXED SIGNAL MICROCONTROLLERS

SLAS165D – FEBRUARY 1998 – REVISED APRIL 2000

## MECHANICAL DATA

FZ (S-CQCC-J\*\*)

28 LEAD SHOWN

J-LEADED CERAMIC CHIP CARRIER

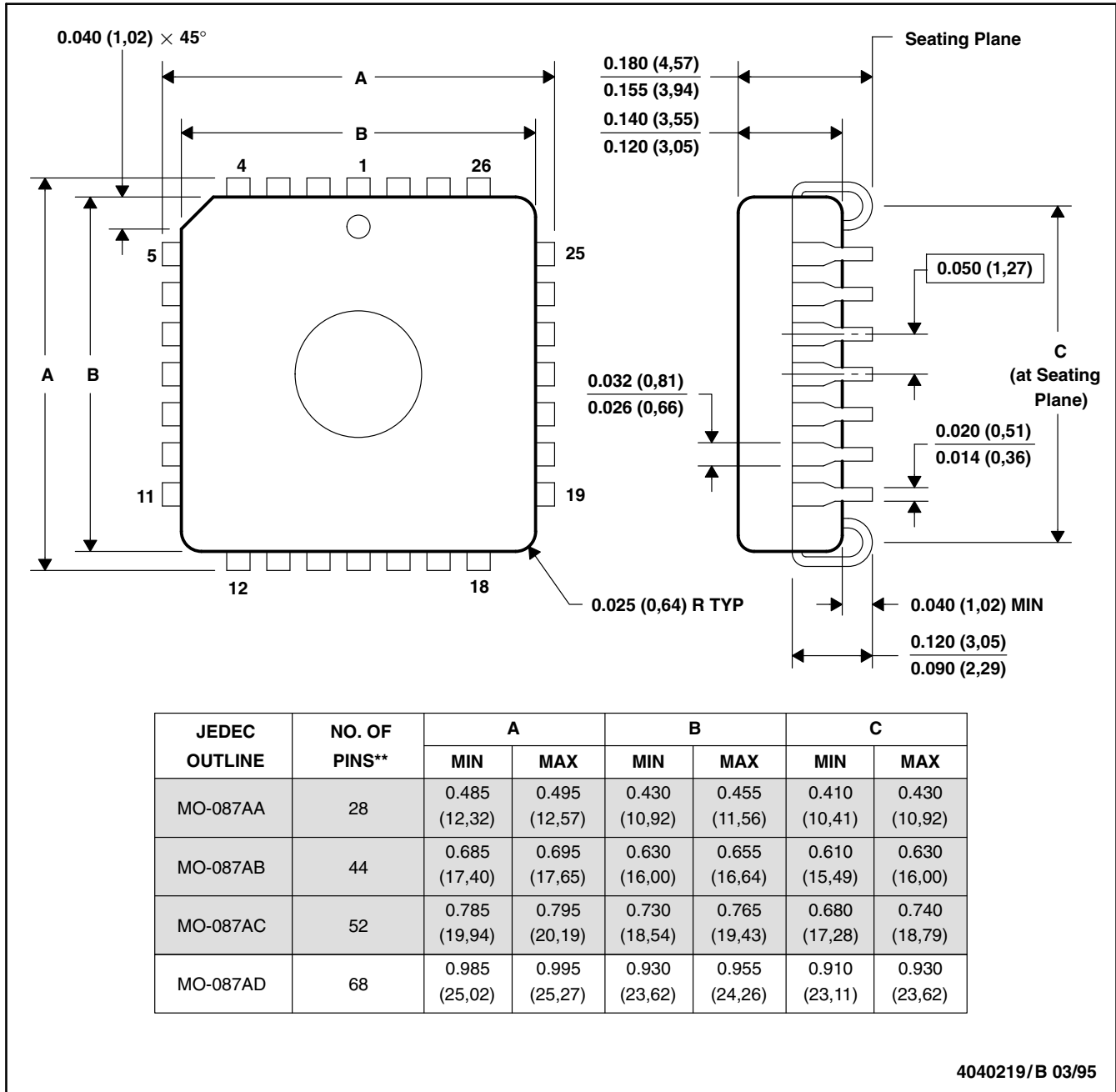

- NOTES: A. All linear dimensions are in inches (millimeters).  
 B. This drawing is subject to change without notice.  
 C. This package can be hermetically sealed with a ceramic lid using glass frit.



POST OFFICE BOX 655303 • DALLAS, TEXAS 75265  
 POST OFFICE BOX 1443 • HOUSTON, TEXAS 77251-1443

## PACKAGING INFORMATION

Orderable Device	Status (1)	Package Type	Package Drawing	Pins	Package Qty	Eco Plan (2)	Lead/Ball Finish (6)	MSL Peak Temp (3)	Op Temp (°C)	Device Marking (4/5)	Samples
MSP430P313IDL	OBSOLETE	SSOP	DL	56		TBD	Call TI	Call TI		M430P313	
MSP430P315IDL	OBSOLETE	SSOP	DL	56		TBD	Call TI	Call TI	-40 to 85	M430P315	
MSP430P315IDLR	OBSOLETE	SSOP	DL	56		TBD	Call TI	Call TI		M430P315	
MSP430P315SIDL	OBSOLETE	SSOP	DL	48		TBD	Call TI	Call TI	-40 to 85	M430P315S	
MSP430P315SIDLR	OBSOLETE	SSOP	DL	48		TBD	Call TI	Call TI		M430P315S	
PMS430E315FZ	OBSOLETE	JLCC	FZ	68		TBD	Call TI	Call TI		PMS430E315FZ	

(1) The marketing status values are defined as follows:

**ACTIVE:** Product device recommended for new designs.

**LIFEBUY:** TI has announced that the device will be discontinued, and a lifetime-buy period is in effect.

**NRND:** Not recommended for new designs. Device is in production to support existing customers, but TI does not recommend using this part in a new design.

**PREVIEW:** Device has been announced but is not in production. Samples may or may not be available.

**OBSOLETE:** TI has discontinued the production of the device.

(2) Eco Plan - The planned eco-friendly classification: Pb-Free (RoHS), Pb-Free (RoHS Exempt), or Green (RoHS & no Sb/Br) - please check <http://www.ti.com/productcontent> for the latest availability information and additional product content details.

**TBD:** The Pb-Free/Green conversion plan has not been defined.

**Pb-Free (RoHS):** TI's terms "Lead-Free" or "Pb-Free" mean semiconductor products that are compatible with the current RoHS requirements for all 6 substances, including the requirement that lead not exceed 0.1% by weight in homogeneous materials. Where designed to be soldered at high temperatures, TI Pb-Free products are suitable for use in specified lead-free processes.

**Pb-Free (RoHS Exempt):** This component has a RoHS exemption for either 1) lead-based flip-chip solder bumps used between the die and package, or 2) lead-based die adhesive used between the die and leadframe. The component is otherwise considered Pb-Free (RoHS compatible) as defined above.

**Green (RoHS & no Sb/Br):** TI defines "Green" to mean Pb-Free (RoHS compatible), and free of Bromine (Br) and Antimony (Sb) based flame retardants (Br or Sb do not exceed 0.1% by weight in homogeneous material)

(3) MSL, Peak Temp. - The Moisture Sensitivity Level rating according to the JEDEC industry standard classifications, and peak solder temperature.

(4) There may be additional marking, which relates to the logo, the lot trace code information, or the environmental category on the device.

(5) Multiple Device Markings will be inside parentheses. Only one Device Marking contained in parentheses and separated by a "~" will appear on a device. If a line is indented then it is a continuation of the previous line and the two combined represent the entire Device Marking for that device.

(6) Lead/Ball Finish - Orderable Devices may have multiple material finish options. Finish options are separated by a vertical ruled line. Lead/Ball Finish values may wrap to two lines if the finish value exceeds the maximum column width.

**Important Information and Disclaimer:** The information provided on this page represents TI's knowledge and belief as of the date that it is provided. TI bases its knowledge and belief on information provided by third parties, and makes no representation or warranty as to the accuracy of such information. Efforts are underway to better integrate information from third parties. TI has taken and continues to take reasonable steps to provide representative and accurate information but may not have conducted destructive testing or chemical analysis on incoming materials and chemicals. TI and TI suppliers consider certain information to be proprietary, and thus CAS numbers and other limited information may not be available for release.

In no event shall TI's liability arising out of such information exceed the total purchase price of the TI part(s) at issue in this document sold by TI to Customer on an annual basis.

# MECHANICAL DATA

DL (R-PDSO-G48)

PLASTIC SMALL-OUTLINE PACKAGE

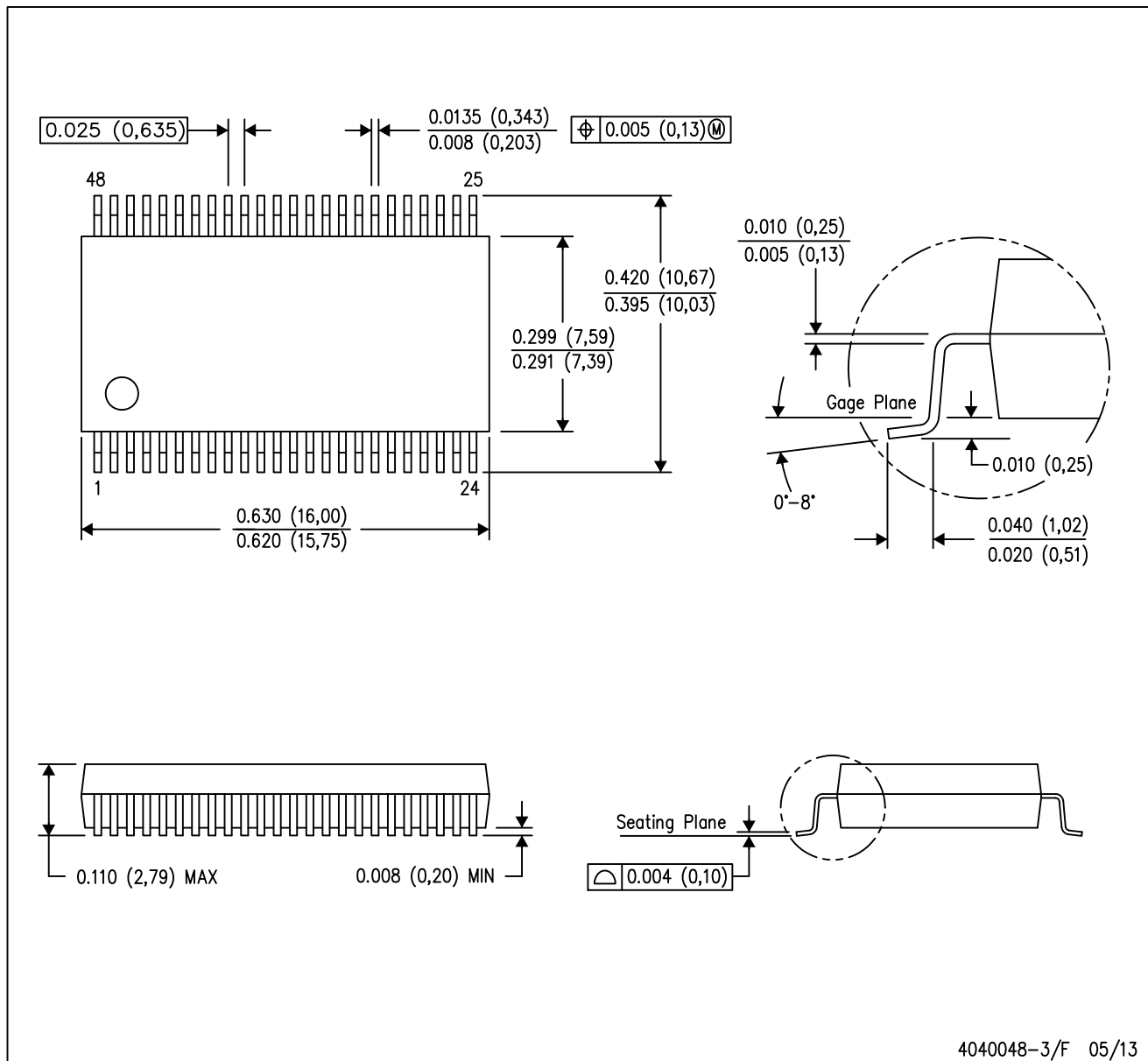

- NOTES:
- All linear dimensions are in inches (millimeters).
  - This drawing is subject to change without notice.
  - Body dimensions do not include mold flash or protrusion not to exceed 0.006 (0,15).
  - Falls within JEDEC MO-118

PowerPAD is a trademark of Texas Instruments.

# MECHANICAL DATA

DL (R-PDSO-G56)

PLASTIC SMALL-OUTLINE PACKAGE

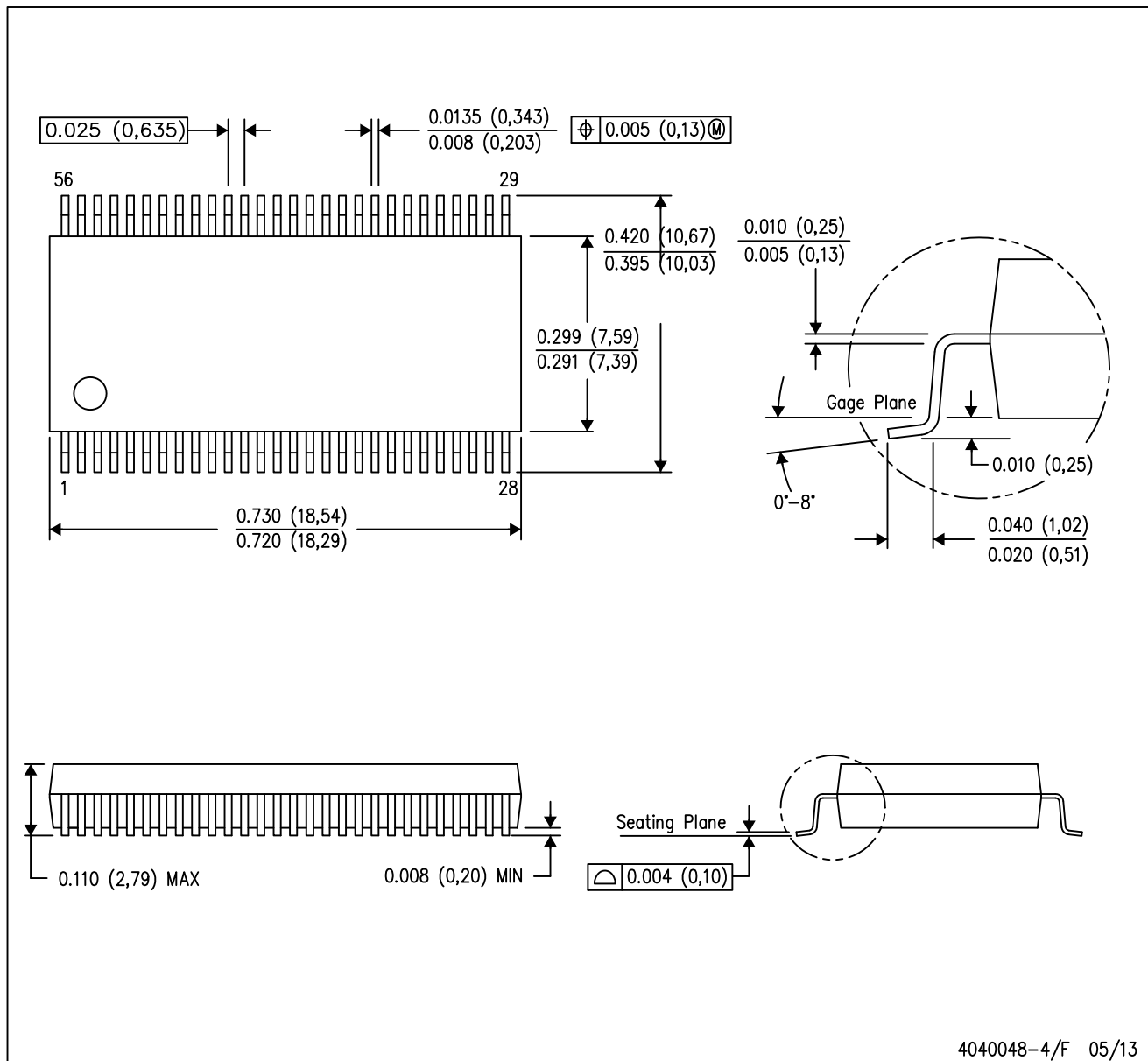

- NOTES:
- A. All linear dimensions are in inches (millimeters).
  - B. This drawing is subject to change without notice.
  - C. Body dimensions do not include mold flash or protrusion not to exceed 0.006 (0,15).
  - D. Falls within JEDEC MO-118

PowerPAD is a trademark of Texas Instruments.

## IMPORTANT NOTICE

Texas Instruments Incorporated and its subsidiaries (TI) reserve the right to make corrections, enhancements, improvements and other changes to its semiconductor products and services per JESD46, latest issue, and to discontinue any product or service per JESD48, latest issue. Buyers should obtain the latest relevant information before placing orders and should verify that such information is current and complete. All semiconductor products (also referred to herein as "components") are sold subject to TI's terms and conditions of sale supplied at the time of order acknowledgment.

TI warrants performance of its components to the specifications applicable at the time of sale, in accordance with the warranty in TI's terms and conditions of sale of semiconductor products. Testing and other quality control techniques are used to the extent TI deems necessary to support this warranty. Except where mandated by applicable law, testing of all parameters of each component is not necessarily performed.

TI assumes no liability for applications assistance or the design of Buyers' products. Buyers are responsible for their products and applications using TI components. To minimize the risks associated with Buyers' products and applications, Buyers should provide adequate design and operating safeguards.

TI does not warrant or represent that any license, either express or implied, is granted under any patent right, copyright, mask work right, or other intellectual property right relating to any combination, machine, or process in which TI components or services are used. Information published by TI regarding third-party products or services does not constitute a license to use such products or services or a warranty or endorsement thereof. Use of such information may require a license from a third party under the patents or other intellectual property of the third party, or a license from TI under the patents or other intellectual property of TI.

Reproduction of significant portions of TI information in TI data books or data sheets is permissible only if reproduction is without alteration and is accompanied by all associated warranties, conditions, limitations, and notices. TI is not responsible or liable for such altered documentation. Information of third parties may be subject to additional restrictions.

Resale of TI components or services with statements different from or beyond the parameters stated by TI for that component or service voids all express and any implied warranties for the associated TI component or service and is an unfair and deceptive business practice. TI is not responsible or liable for any such statements.

Buyer acknowledges and agrees that it is solely responsible for compliance with all legal, regulatory and safety-related requirements concerning its products, and any use of TI components in its applications, notwithstanding any applications-related information or support that may be provided by TI. Buyer represents and agrees that it has all the necessary expertise to create and implement safeguards which anticipate dangerous consequences of failures, monitor failures and their consequences, lessen the likelihood of failures that might cause harm and take appropriate remedial actions. Buyer will fully indemnify TI and its representatives against any damages arising out of the use of any TI components in safety-critical applications.

In some cases, TI components may be promoted specifically to facilitate safety-related applications. With such components, TI's goal is to help enable customers to design and create their own end-product solutions that meet applicable functional safety standards and requirements. Nonetheless, such components are subject to these terms.

No TI components are authorized for use in FDA Class III (or similar life-critical medical equipment) unless authorized officers of the parties have executed a special agreement specifically governing such use.

Only those TI components which TI has specifically designated as military grade or "enhanced plastic" are designed and intended for use in military/aerospace applications or environments. Buyer acknowledges and agrees that any military or aerospace use of TI components which have **not** been so designated is solely at the Buyer's risk, and that Buyer is solely responsible for compliance with all legal and regulatory requirements in connection with such use.

TI has specifically designated certain components as meeting ISO/TS16949 requirements, mainly for automotive use. In any case of use of non-designated products, TI will not be responsible for any failure to meet ISO/TS16949.

### Products

Audio	<a href="http://www.ti.com/audio">www.ti.com/audio</a>
Amplifiers	<a href="http://amplifier.ti.com">amplifier.ti.com</a>
Data Converters	<a href="http://dataconverter.ti.com">dataconverter.ti.com</a>
DLP® Products	<a href="http://www.dlp.com">www.dlp.com</a>
DSP	<a href="http://dsp.ti.com">dsp.ti.com</a>
Clocks and Timers	<a href="http://www.ti.com/clocks">www.ti.com/clocks</a>
Interface	<a href="http://interface.ti.com">interface.ti.com</a>
Logic	<a href="http://logic.ti.com">logic.ti.com</a>
Power Mgmt	<a href="http://power.ti.com">power.ti.com</a>
Microcontrollers	<a href="http://microcontroller.ti.com">microcontroller.ti.com</a>
RFID	<a href="http://www.ti-rfid.com">www.ti-rfid.com</a>
OMAP Applications Processors	<a href="http://www.ti.com/omap">www.ti.com/omap</a>
Wireless Connectivity	<a href="http://www.ti.com/wirelessconnectivity">www.ti.com/wirelessconnectivity</a>

### Applications

Automotive and Transportation	<a href="http://www.ti.com/automotive">www.ti.com/automotive</a>
Communications and Telecom	<a href="http://www.ti.com/communications">www.ti.com/communications</a>
Computers and Peripherals	<a href="http://www.ti.com/computers">www.ti.com/computers</a>
Consumer Electronics	<a href="http://www.ti.com/consumer-apps">www.ti.com/consumer-apps</a>
Energy and Lighting	<a href="http://www.ti.com/energy">www.ti.com/energy</a>
Industrial	<a href="http://www.ti.com/industrial">www.ti.com/industrial</a>
Medical	<a href="http://www.ti.com/medical">www.ti.com/medical</a>
Security	<a href="http://www.ti.com/security">www.ti.com/security</a>
Space, Avionics and Defense	<a href="http://www.ti.com/space-avionics-defense">www.ti.com/space-avionics-defense</a>
Video and Imaging	<a href="http://www.ti.com/video">www.ti.com/video</a>

### TI E2E Community

[e2e.ti.com](http://e2e.ti.com)

## Looking for pricing, stock, or lifecycle information?

Click below to explore more details on WIN SOURCE:

 [View MSP430P315IDL on WIN SOURCE](#)

 [Texas Instruments](#) Information

## Optimize Your Supply Chain with WIN SOURCE Solutions

-  Global Sourcing Solution
-  Obsolete Management
-  Cost Control Management
-  Shortage Management
-  Alternative Solution
-  Excess Inventory Management