



THE DATASHEET OF MSP430F5529IPNR



MSP430F552x, MSP430F551x Mixed-Signal Microcontrollers

1 Features

- Low supply voltage range: 3.6 V down to 1.8 V
- Ultra-low power consumption
 - Active mode (AM):
 - All system clocks active:
 - 290 μ A/MHz at 8 MHz, 3.0 V, flash program execution (typical)
 - 150 μ A/MHz at 8 MHz, 3.0 V, RAM program execution (typical)
 - Standby mode (LPM3):
 - Real-time clock (RTC) with crystal, watchdog, and supply supervisor operational, full RAM retention, fast wakeup:
 - 1.9 μ A at 2.2 V, 2.1 μ A at 3.0 V (typical)
 - Low-power oscillator (VLO), general-purpose counter, watchdog, and supply supervisor operational, full RAM retention, fast wakeup:
 - 1.4 μ A at 3.0 V (typical)
 - Off mode (LPM4):
 - Full RAM retention, supply supervisor operational, fast wakeup:
 - 1.1 μ A at 3.0 V (typical)
 - Shutdown mode (LPM4.5):
 - 0.18 μ A at 3.0 V (typical)
- Wake up from standby mode in 3.5 μ s (typical)
- 16-bit RISC architecture, extended memory, up to 25-MHz system clock
- Flexible power-management system
 - Fully integrated LDO with programmable regulated core supply voltage
 - Supply voltage supervision, monitoring, and brownout
- Unified clock system
 - FLL control loop for frequency stabilization
 - Low-power low-frequency internal clock source (VLO)
 - Low-frequency trimmed internal reference source (REFO)
 - 32-kHz watch crystals (XT1)
 - High-frequency crystals up to 32 MHz (XT2)
- 16-bit timer TA0, Timer_A with five capture/compare registers
- 16-bit timer TA1, Timer_A with three capture/compare registers
- 16-bit timer TA2, Timer_A with three capture/compare registers
- 16-bit timer TB0, Timer_B with seven capture/compare shadow registers
- Two universal serial communication interfaces (USCIs)
 - USCI_A0 and USCI_A1 each support:
 - Enhanced UART supports automatic baud-rate detection
 - IrDA encoder and decoder
 - Synchronous SPI
 - USCI_B0 and USCI_B1 each support:
 - I²C
 - Synchronous SPI
- Full-speed universal serial bus (USB)
 - Integrated USB-PHY
 - Integrated 3.3-V and 1.8-V USB power system
 - Integrated USB-PLL
 - Eight input and eight output endpoints
- 12-bit analog-to-digital converter (ADC) (MSP430F552x only) with internal reference, sample-and-hold, and autoscan features
- Comparator
- Hardware multiplier supports 32-bit operations
- Serial onboard programming, no external programming voltage needed
- 3-channel internal DMA
- Basic timer with RTC feature
- Development tools and software (also see [Tools and Software](#))
 - LaunchPad™ development kit ([MSP-EXP430F5529LP](#))
 - MSP430F5529 experimenter's board ([MSP-EXP430F5529](#))
 - 80-pin target development board ([MSP-TS430PN80USB](#))
 - 64-pin target development board ([MSP-TS430RGC64USB](#))
 - USB developers package ([MSP430USBDEVPACK](#))
 - [MSP430Ware™](#) code examples
- [Device Comparison](#) summarizes the available family members

2 Applications

- Analog and digital sensor systems
- Data loggers
- Connection to USB hosts



3 Description

The Texas Instruments MSP430F55xx microcontrollers (MCUs) are part of the MSP430™ system control & communication family of ultra-low-power microcontrollers consists of several devices featuring peripheral sets targeted for a variety of applications. The architecture, combined with extensive low-power modes, is optimized to achieve extended battery life in portable measurement applications. The microcontroller features a powerful 16-bit RISC CPU, 16-bit registers, and constant generators that contribute to maximum code efficiency. The digitally controlled oscillator (DCO) allows the devices to wake up from low-power modes to active mode in 3.5 μs (typical).

The MSP430F5529, MSP430F5527, MSP430F5525, and MSP430F5521 microcontrollers have integrated USB and PHY supporting USB 2.0, four 16-bit timers, a high-performance 12-bit analog-to-digital converter (ADC), two USCIs, a hardware multiplier, DMA, an RTC module with alarm capabilities, and 63 I/O pins. The MSP430F5528, MSP430F5526, MSP430F5524, and MSP430F5522 microcontrollers include all of these peripherals but have 47 I/O pins.

The MSP430F5519, MSP430F5517, and MSP430F5515 microcontrollers have integrated USB and PHY supporting USB 2.0, four 16-bit timers, two USCIs, a hardware multiplier, DMA, an RTC module with alarm capabilities, and 63 I/O pins. The MSP430F5514 and MSP430FF5513 microcontrollers include all of these peripherals but have 47 I/O pins.

Typical applications include analog and digital sensor systems, data loggers, and others that require connectivity to various USB hosts.

The MSP430F55xx MCUs are supported by an extensive hardware and software ecosystem with reference designs and code examples to get your design started quickly. Development kits include the [MSP430F5529 USB LaunchPad™ development kit](#) and the [MSP430F5529 experimenter's board](#) as well as the [MSP-TS430PN80USB](#) 80-pin target development board and the [MSP-TS430RGC64USB](#) 64-pin target development board. TI also provides free [MSP430Ware™ software](#), which is available as a component of [Code Composer Studio™ IDE](#) desktop and cloud versions within [TI Resource Explorer](#). The MSP430 MCUs are also supported by extensive online collateral, training, and online support through the [TI E2E™ support forum](#).

For complete module descriptions, see the [MSP430F5xx and MSP430F6xx Family User's Guide](#).

Device Information

PART NUMBER ⁽¹⁾	PACKAGE	BODY SIZE ⁽²⁾
MSP430F5529IPN	LQFP (80)	12 mm × 12 mm
MSP430F5528IRGC	VQFN (64)	9 mm × 9 mm
MSP430F5528IYFF	DSBGA (64)	See Section 11
MSP430F5528IZXH	nFBGA (80)	5 mm × 5 mm
MSP430F5528IZQE ⁽³⁾	MicroStar Junior™ BGA (80)	5 mm × 5 mm

- (1) For the most current part, package, and ordering information for all available devices, see the *Package Option Addendum* in [Section 11](#), or see the TI website at www.ti.com.
- (2) The sizes shown here are approximations. For the package dimensions with tolerances, see the *Mechanical Data* in [Section 11](#).
- (3) All orderable part numbers in the ZQE (MicroStar Junior BGA) package have been changed to a status of Last Time Buy. Visit the [Product life cycle](#) page for details on this status.

4 Functional Block Diagrams

Figure 4-1 shows the functional block diagram for the MSP430F5529, MSP430F5527, MSP430F5525, and MSP430F5521 devices in the PN package.

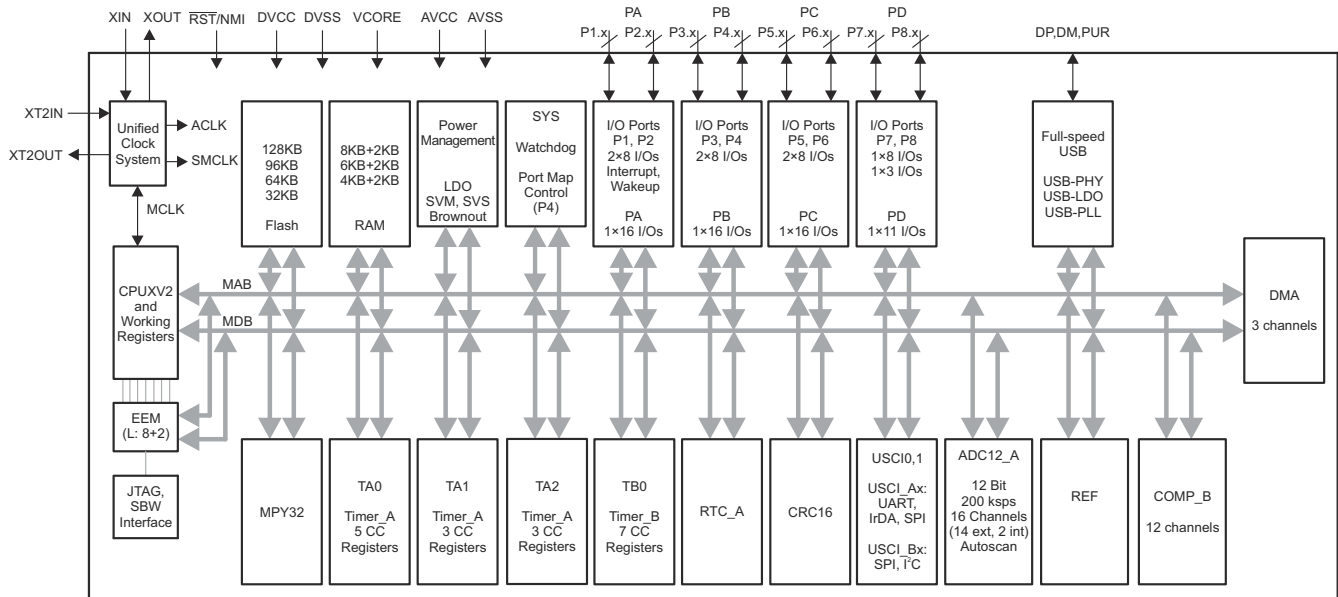

Figure 4-1. Functional Block Diagram – MSP430F5529IPN, MSP430F5527IPN, MSP430F5525IPN, MSP430F5521IPN

Figure 4-2 shows the functional block diagram for the MSP430F5528, MSP430F5526, MSP430F5524, and MSP430F5522 devices in the RGC, ZXH, and ZQE packages and for the MSP430F5528 device in the YFF package.

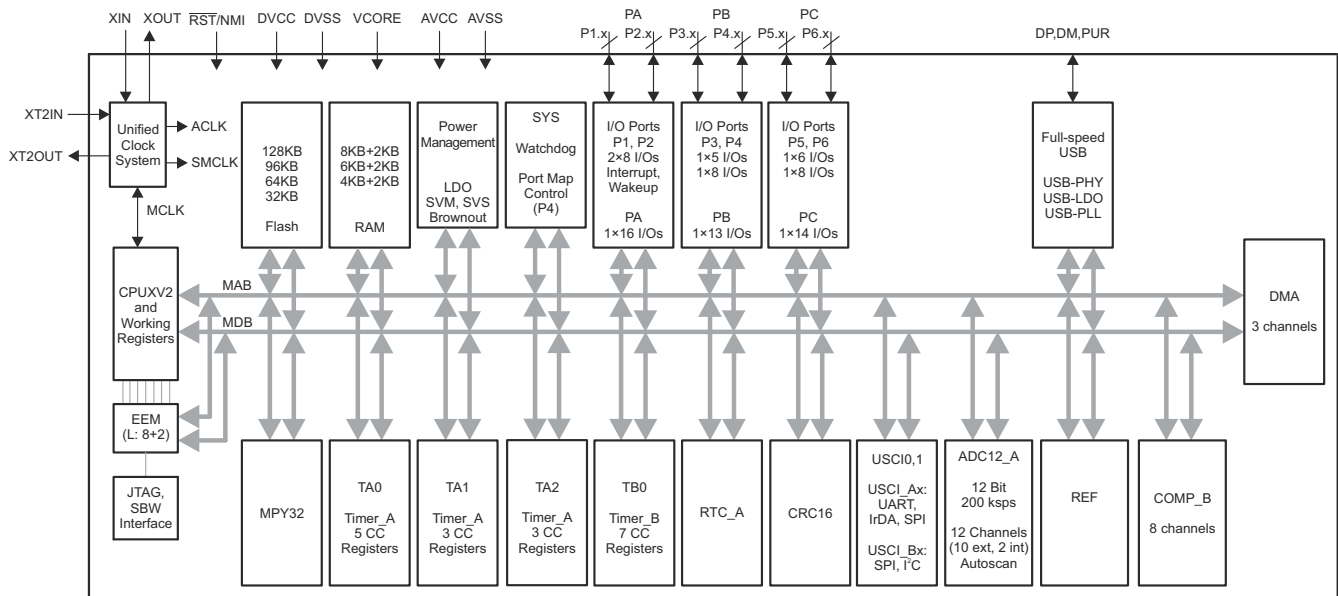

Figure 4-2. Functional Block Diagram – MSP430F5528IRGC, MSP430F5526IRGC, MSP430F5524IRGC, MSP430F5522IRGC, MSP430F5528IZXH, MSP430F5526IZXH, MSP430F5524IZXH, MSP430F5522IZXH, MSP430F5528IZQE, MSP430F5526IZQE, MSP430F5524IZQE, MSP430F5522IZQE, MSP430F5528IYFF

Figure 4-3 shows the functional block diagram for the MSP430F5519, MSP430F5517, and MSP430F5515 devices in the PN package.

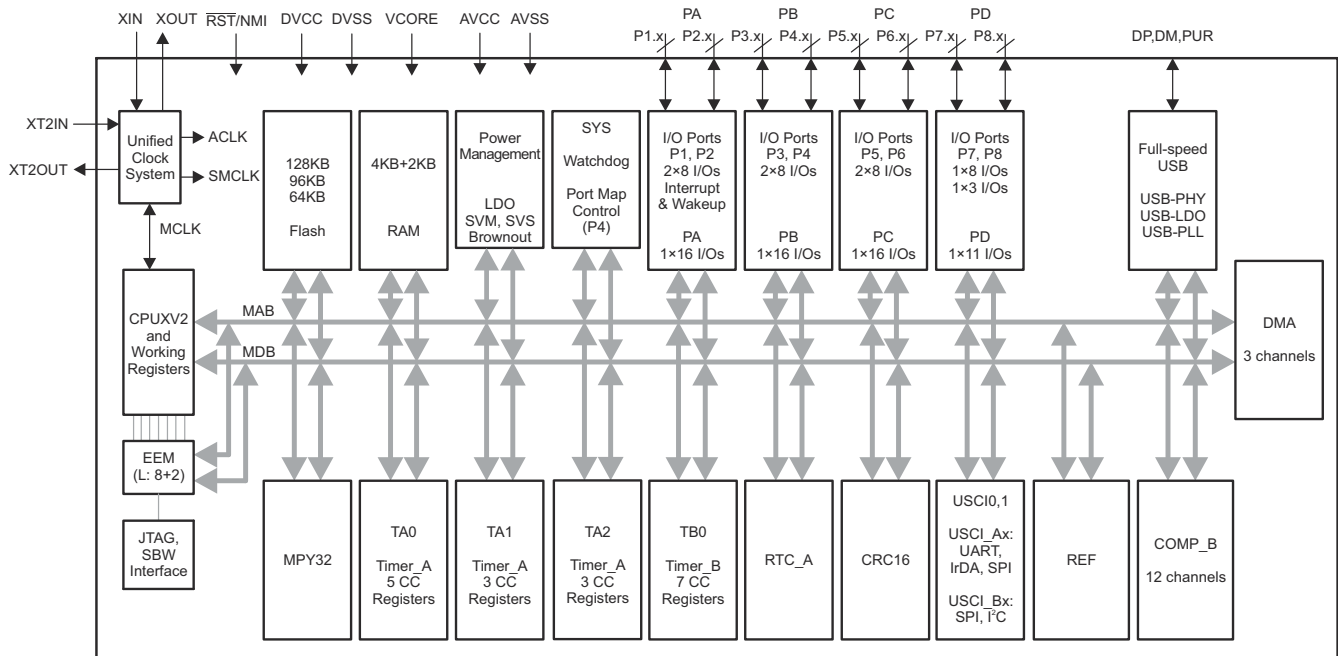

Figure 4-3. Functional Block Diagram – MSP430F5519IPN, MSP430F5517IPN, MSP430F5515IPN

Figure 4-4 shows the functional block diagram for the MSP430F5514 and MSP430F5513 devices in the RGC, ZXH, and ZQE packages.

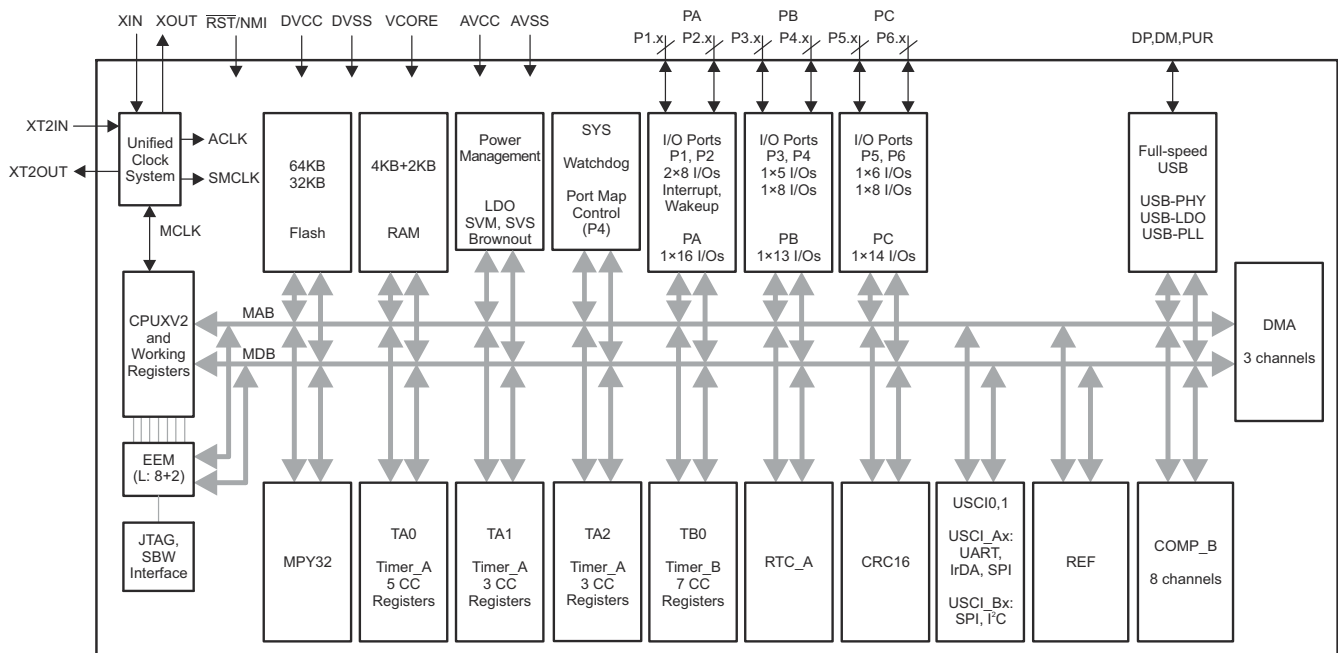

Figure 4-4. Functional Block Diagram – MSP430F5514IRGC, MSP430F5513IRGC, MSP430F5514IZXH, MSP430F5513IZXH, MSP430F5514IZQE, MSP430F5513IZQE

Table of Contents

1 Features	1	8.25 PMM, SVM Low Side.....	36
2 Applications	1	8.26 Wake-up Times From Low-Power Modes and Reset.....	37
3 Description	2	8.27 Timer_A.....	37
4 Functional Block Diagrams	3	8.28 Timer_B.....	37
5 Revision History	6	8.29 USCI (UART Mode) Clock Frequency.....	38
6 Device Comparison	9	8.30 USCI (UART Mode).....	38
6.1 Related Products.....	9	8.31 USCI (SPI Master Mode) Clock Frequency.....	39
7 Terminal Configuration and Functions	10	8.32 USCI (SPI Master Mode).....	39
7.1 Pin Diagrams.....	10	8.33 USCI (SPI Slave Mode).....	41
7.2 Signal Descriptions.....	16	8.34 USCI (I ² C Mode).....	43
8 Specifications	22	8.35 12-Bit ADC, Power Supply and Input Range Conditions.....	44
8.1 Absolute Maximum Ratings.....	22	8.36 12-Bit ADC, Timing Parameters.....	44
8.2 ESD Ratings.....	22	8.37 12-Bit ADC, Linearity Parameters Using an External Reference Voltage or AVCC as Reference Voltage.....	45
8.3 Recommended Operating Conditions.....	23	8.38 12-Bit ADC, Linearity Parameters Using the Internal Reference Voltage.....	45
8.4 Active Mode Supply Current Into V _{CC} Excluding External Current.....	24	8.39 12-Bit ADC, Temperature Sensor and Built-In V _{MID}	46
8.5 Low-Power Mode Supply Currents (Into V _{CC}) Excluding External Current.....	25	8.40 REF, External Reference.....	47
8.6 Thermal Resistance Characteristics.....	26	8.41 REF, Built-In Reference.....	47
8.7 Schmitt-Trigger Inputs – General-Purpose I/O (P1.0 to P1.7, P2.0 to P2.7, P3.0 to P3.7, P4.0 to P4.7, P5.0 to P5.7, P6.0 to P6.7, P7.0 to P7.7, P8.0 to P8.2, PJ.0 to PJ.3, $\overline{\text{RST}}/\text{NMI}$).....	26	8.42 Comparator_B.....	49
8.8 Inputs – Ports P1 and P2 (P1.0 to P1.7, P2.0 to P2.7).....	26	8.43 Ports PU.0 and PU.1.....	49
8.9 Leakage Current – General-Purpose I/O (P1.0 to P1.7, P2.0 to P2.7, P3.0 to P3.7, P4.0 to P4.7) (P5.0 to P5.7, P6.0 to P6.7, P7.0 to P7.7, P8.0 to P8.2, PJ.0 to PJ.3, $\overline{\text{RST}}/\text{NMI}$).....	27	8.44 USB Output Ports DP and DM.....	51
8.10 Outputs – General-Purpose I/O (Full Drive Strength) (P1.0 to P1.7, P2.0 to P2.7, P3.0 to P3.7, P4.0 to P4.7, P5.0 to P5.7, P6.0 to P6.7, P7.0 to P7.7, P8.0 to P8.2, PJ.0 to PJ.3).....	27	8.45 USB Input Ports DP and DM.....	51
8.11 Outputs – General-Purpose I/O (Reduced Drive Strength) (P1.0 to P1.7, P2.0 to P2.7, P3.0 to P3.7, P4.0 to P4.7, P5.0 to P5.7, P6.0 to P6.7, P7.0 to P7.7, P8.0 to P8.2, PJ.0 to PJ.3).....	27	8.46 USB-PWR (USB Power System).....	51
8.12 Output Frequency – General-Purpose I/O (P1.0 to P1.7, P2.0 to P2.7, P3.0 to P3.7, P4.0 to P4.7, P5.0 to P5.7, P6.0 to P6.7, P7.0 to P7.7, P8.0 to P8.2, PJ.0 to PJ.3).....	28	8.47 USB-PLL (USB Phase-Locked Loop).....	52
8.13 Typical Characteristics – Outputs, Reduced Drive Strength (PxDS.y = 0).....	29	8.48 Flash Memory.....	52
8.14 Typical Characteristics – Outputs, Full Drive Strength (PxDS.y = 1).....	30	8.49 JTAG and Spy-Bi-Wire Interface.....	52
8.15 Crystal Oscillator, XT1, Low-Frequency Mode.....	31	9 Detailed Description	53
8.16 Crystal Oscillator, XT2.....	32	9.1 CPU.....	53
8.17 Internal Very-Low-Power Low-Frequency Oscillator (VLO).....	33	9.2 Operating Modes.....	54
8.18 Internal Reference, Low-Frequency Oscillator (REFO).....	33	9.3 Interrupt Vector Addresses.....	55
8.19 DCO Frequency.....	34	9.4 Memory Organization.....	56
8.20 PMM, Brownout Reset (BOR).....	35	9.5 Bootloader (BSL).....	57
8.21 PMM, Core Voltage.....	35	9.6 JTAG Operation.....	58
8.22 PMM, SVS High Side.....	35	9.7 Flash Memory.....	59
8.23 PMM, SVM High Side.....	36	9.8 RAM.....	59
8.24 PMM, SVS Low Side.....	36	9.9 Peripherals.....	59
		9.10 Input/Output Diagrams.....	83
		9.11 Device Descriptors (TLV).....	107
		10 Device and Documentation Support	113
		10.1 Getting Started and Next Steps.....	113
		10.2 Device Nomenclature.....	113
		10.3 Tools and Software.....	115
		10.4 Documentation Support.....	117
		10.5 Related Links.....	119
		10.6 Support Resources.....	120
		10.7 Trademarks.....	120
		10.8 Electrostatic Discharge Caution.....	120
		10.9 Export Control Notice.....	120
		10.10 Glossary.....	120
		11 Mechanical, Packaging, and Orderable Information	121

5 Revision History

NOTE: Page numbers for previous revisions may differ from page numbers in the current version.

Changes from revision O to revision P

Changes from May 1, 2019 to September 11, 2020	Page
• Updated the numbering for sections, tables, figures, and cross-references throughout the document.....	1
• Added nFBGA package (ZXH) information throughout document.....	2
• Added note about status change for all orderable part numbers in the ZQE package in Device Information ...	2
• Added note (1) in Section 8.6, Thermal Resistance Characteristics	26
• Changed the MAX value of the I _{ERASE} and I _{MERASE} , I _{BANK} parameters in Section 8.48, Flash Memory	52

Changes from revision N to revision O

Changes from September 21, 2018 to April 30, 2019	Page
• Updated Section 1, Features	1
• Updated Section 3, Description	2
• Removed the YFF package option for the MSP430F5526 and MSP430F5524 in Section 4, Functional Block Diagrams	3
• Removed the YFF package option for the MSP430F5526 and MSP430F5524 in Section 6, Device Comparison	9
• Removed the YFF package option for the MSP430F5526 and MSP430F5524 in Figure 7-6, 64-Pin YFF Package – MSP430F5528IYFF	10

Changes from revision M to revision N

Changes from November 3, 2015 to September 20, 2018	Page
• Changed entry for Body Size of DSBGA package in <i>Device Information</i> table	2
• Added Section 6.1, Related Products	9
• Removed D and E dimension lines from the YFF pinout (for package dimensions, see the <i>Mechanical Data</i> in Section 11)	10
• Added typical conditions statements at the beginning of Section 8, Specifications	22
• Changed the MIN value of the V _(DVCC_BOR_hys) parameter from 60 mV to 50 mV in Section 8.20, PMM, Brownout Reset (BOR)	35
• Updated notes (1) and (2) and added note (3) in Section 8.26, Wake-up Times From Low-Power Modes and Reset	37
• Removed ADC12DIV from the formula for the TYP value in the second row of the t _{CONVERT} parameter in Section 8.36, 12-Bit ADC, Timing Parameters , because ADC12CLK is after division.....	44
• Added second row for t _{EN_CMP} with Test Conditions of "CBPWRMD = 10" and MAX value of 100 μs in Section 8.42, Comparator_B	49
• Renamed FCTL4.MGR0 and MGR1 bits in the f _{MCLK,MGR} parameter in Section 8.48, Flash Memory , to be consistent with header files	52
• Throughout document, changed all instances of "bootstrap loader" to "bootloader".....	57
• Added YFF pin numbers to Table 9-11, TA0 Signal Connections	65
• Added YFF pin numbers to Table 9-12, TA1 Signal Connections	66
• Added YFF pin numbers to Table 9-13, TA2 Signal Connections	67
• Replaced former section <i>Development Tools Support</i> with Section 10.3, Tools and Software	115
• Changed format and added content to Section 10.4, Documentation Support	117

Changes from revision L to revision M

Changes from June 17, 2013 to November 2, 2015

Page

• Added <i>Device Information</i> table.....	2
• Added Section 4 and moved all functional block diagrams to it.....	3
• Added Section 6 and moved Table 6-1 table to it.....	9
• Added Section 8.2 , <i>ESD Ratings</i>	22
• Moved Section 8.6 , <i>Thermal Resistance Characteristics</i>	26
• Changed the TYP value of $C_{L,eff}$ with Test Conditions of "XTS = 0, XCAPx = 0" from 2 pF to 1 pF.....	31
• Corrected MRG0 and MRG1 bit names in $f_{MCLK,MRG}$ parameter description.....	52
• Corrected spelling of NMIIFG in Table 9-9 , <i>System Module Interrupt Vector Registers</i>	62
• Corrected register names (added "USB" prefix as necessary) in Table 9-45 , <i>USB Control Registers</i>	70
• Changed P5.3 schematic (added P5SEL.2 and XT2BYPASS inputs, AND gate, and OR gate after P5SEL.3)..	92
• Changed P5SEL.3 column from X to 0 for "P5.3 (I/O)" rows.....	92
• Changed P5.5 schematic (change input from P5SEL.5 to P5SEL.4 and added P5SEL.5 input and the following OR gate).....	94
• Changed P5SEL.5 column from X to 0 for "P5.5 (I/O)" rows.....	94
• Added Section 11 , <i>Mechanical, Packaging, and Orderable Information</i>	121

The following table lists the changes to this data sheet from the initial release through revision L.

REVISION	DESCRIPTION
SLAS590L June 2013	Production release of F5226 and F5224 in YFF package. Section 7.2 , Added note regarding pullup resistor on $\overline{RST}/NMI/SBWTIO$ pin. Figure 7-6 , Added ball-side view and changed top-side view.
SLAS590K February 2013	Section 8.48 , Changed I_{ERASE} and I_{MERASE} values.
SLAS590J December 2012	Section 8.3 , Added TYP test conditions Section 8.19 , Added note (1) Section 8.48 , Restored Flash erase currents to previous values (changed from TBD).
SLAS590I August 2012	Changed MSP430F5528IYFF to Production Data. Section 7.2 , Changed PUR pin description. Section 9.5.1 , Added note regarding PUR pin. Table 9-9 , Changed SYSRSTIV interrupt event with value 1Ch to Reserved. Section 8.3 , Added note regarding interaction between minimum VCC and SVSH. Section 8.39 , Changed $t_{SENSOR(sample) MIN}$ to 100 μs , and changed note (2).
SLAS590H February 2012	Corrected lost and corrupted symbols throughout. Affected symbols include: $\Delta \theta \rightarrow \geq \neq$ Changed ACLK signal description in Section 7.2 . Changed note on Section 8.37 . Changed notes regarding UCA0CLK and UCB0CLK function on Table 9-47 and Table 9-48 .

REVISION	DESCRIPTION
SLAS590G November 2011	<p>Changed limits for wake-up time, LPM3/4 current, reference current, ADC12 maximum frequency, ADC linearity — see the following tables:</p> <p>Section 8.5 Section 8.35 Section 8.36 Section 8.37 Section 8.38 Section 8.40 Section 8.41</p> <p>Changed notes regarding crystal capacitance in Section 8.15</p>
SLAS590F November 2011	Corrected terminal assignments for YFF package in Section 7.1 and Section 7.2
SLAS590E April 2011	<p>Updated YFF and ZQE pinout drawings.</p> <p>Changed T_{stg} maximum to 150°C in Section 8.1.</p> <p>Changed $f_{XT2,HF,SW}$ MIN to 0.7 MHz in Section 8.16.</p>
SLAS590D April 2010	Production data release
SLAS590C January 2010	Changes throughout for updated preview
SLAS590B July 2009	Changes throughout for updated preview
SLAS590A May 2009	Changes throughout for XMS430F5529 sampling
SLAS590 September 2008	Limited product preview release

6 Device Comparison

Table 6-1 summarizes the available family members.

Table 6-1. Device Comparison

DEVICE ^{(1) (2)}	FLASH (KB)	SRAM (KB) ⁽⁵⁾	Timer_A ⁽³⁾	Timer_B ⁽⁴⁾	USCI_A: UART, IrDA, SPI	USCI_B: SPI, I ² C	ADC12_A (channels)	COMP_B (channels)	I/Os	PACKAGE
MSP430F5529	128	8 + 2	5, 3, 3	7	2	2	14 ext, 2 int	12	63	80 PN
MSP430F5528	128	8 + 2	5, 3, 3	7	2	2	10 ext, 2 int	8	47	64 RGC, 64 YFF, 80 ZXH, 80 ZQE
MSP430F5527	96	6 + 2	5, 3, 3	7	2	2	14 ext, 2 int	12	63	80 PN
MSP430F5526	96	6 + 2	5, 3, 3	7	2	2	10 ext, 2 int	8	47	64 RGC, 80 ZXH, 80 ZQE
MSP430F5525	64	4 + 2	5, 3, 3	7	2	2	14 ext, 2 int	12	63	80 PN
MSP430F5524	64	4 + 2	5, 3, 3	7	2	2	10 ext, 2 int	8	47	64 RGC, 80 ZXH, 80 ZQE
MSP430F5522	32	8 + 2	5, 3, 3	7	2	2	10 ext, 2 int	8	47	64 RGC, 80 ZXH, 80 ZQE
MSP430F5521	32	6 + 2	5, 3, 3	7	2	2	14 ext, 2 int	12	63	80 PN
MSP430F5519	128	8 + 2	5, 3, 3	7	2	2	–	12	63	80 PN
MSP430F5517	96	6 + 2	5, 3, 3	7	2	2	–	12	63	80 PN
MSP430F5515	64	4 + 2	5, 3, 3	7	2	2	–	12	63	80 PN
MSP430F5514	64	4 + 2	5, 3, 3	7	2	2	–	8	47	64 RGC, 80 ZXH, 80 ZQE
MSP430F5513	32	4 + 2	5, 3, 3	7	2	2	–	8	47	64 RGC, 80 ZXH, 80 ZQE

- (1) For the most current part, package, and ordering information for all available devices, see the *Package Option Addendum* in [Section 11](#), or see the TI website at www.ti.com.
- (2) Package drawings, thermal data, and symbolization are available at www.ti.com/packaging.
- (3) Each number in the sequence represents an instantiation of Timer_A with its associated number of capture/compare registers and PWM output generators available. For example, a number sequence of 3, 5 would represent two instantiations of Timer_A, the first instantiation having 3 and the second instantiation having 5 capture/compare registers and PWM output generators, respectively.
- (4) Each number in the sequence represents an instantiation of Timer_B with its associated number of capture/compare registers and PWM output generators available. For example, a number sequence of 3, 5 would represent two instantiations of Timer_B, the first instantiation having 3 and the second instantiation having 5 capture/compare registers and PWM output generators, respectively.
- (5) The additional 2KB of USB SRAM that is listed can be used as general-purpose SRAM when USB is not in use.

6.1 Related Products

For information about other devices in this family of products or related products, see the following links.

[TI 16-bit and 32-bit microcontrollers](#)

High-performance, low-power solutions to enable the autonomous future

[Products for MSP430 ultra-low-power sensing & measurement MCUs](#)

One platform. One ecosystem. Endless possibilities.

[Companion products for MSP430F5529](#)

Review products that are frequently purchased or used with this product.

[Reference designs for MSP430F5529](#)

Find reference designs leveraging the best in TI technology to solve your system-level challenges.

Figure 7-2 shows the pinout for the MSP430F5528, MSP430F5526, MSP430F5524, and MSP430F5522 devices in the 64-pin RGC package.

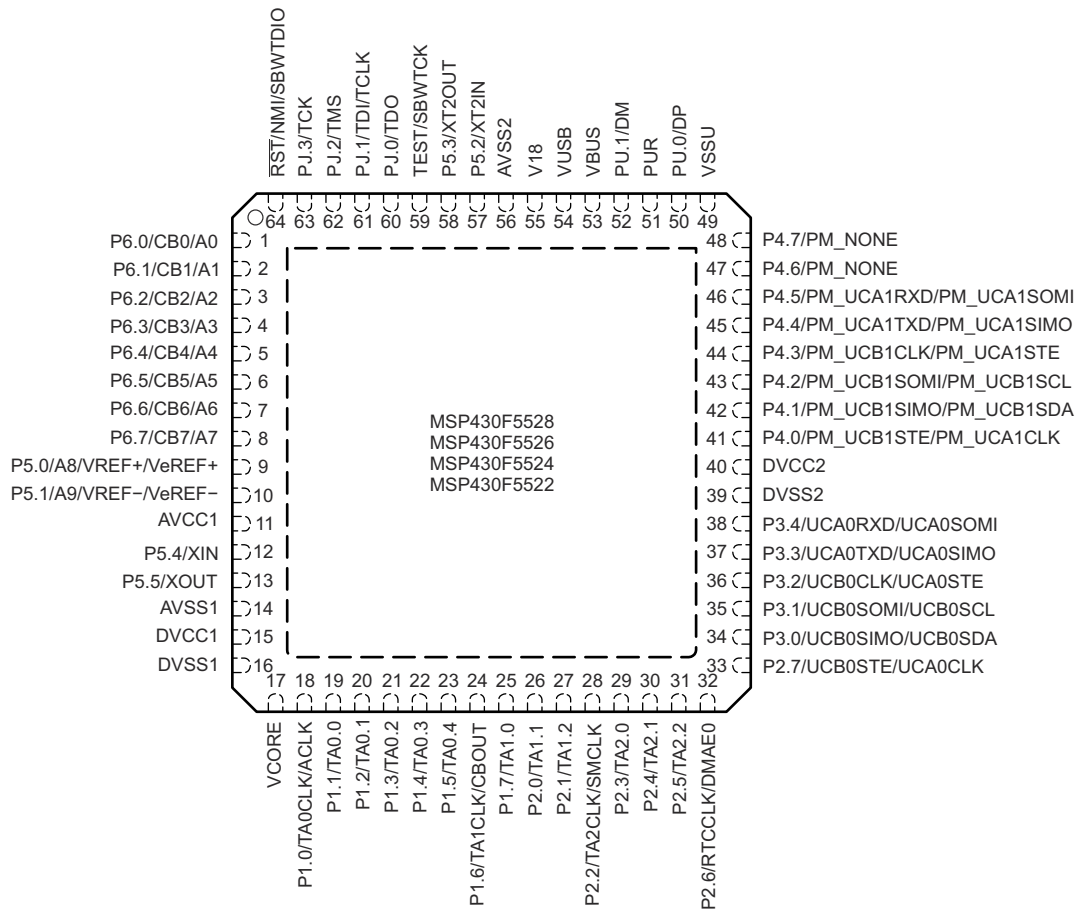

TI recommends connecting the exposed thermal pad to V_{SS}.

Figure 7-2. 64-Pin RGC Package (Top View) – MSP430F5528IRGC, MSP430F5526IRGC, MSP430F5524IRGC, MSP430F5522IRGC

Figure 7-3 shows the pinout for the MSP430F5519, MSP430F5517, and MSP430F5515 devices in the 80-pin PN package.

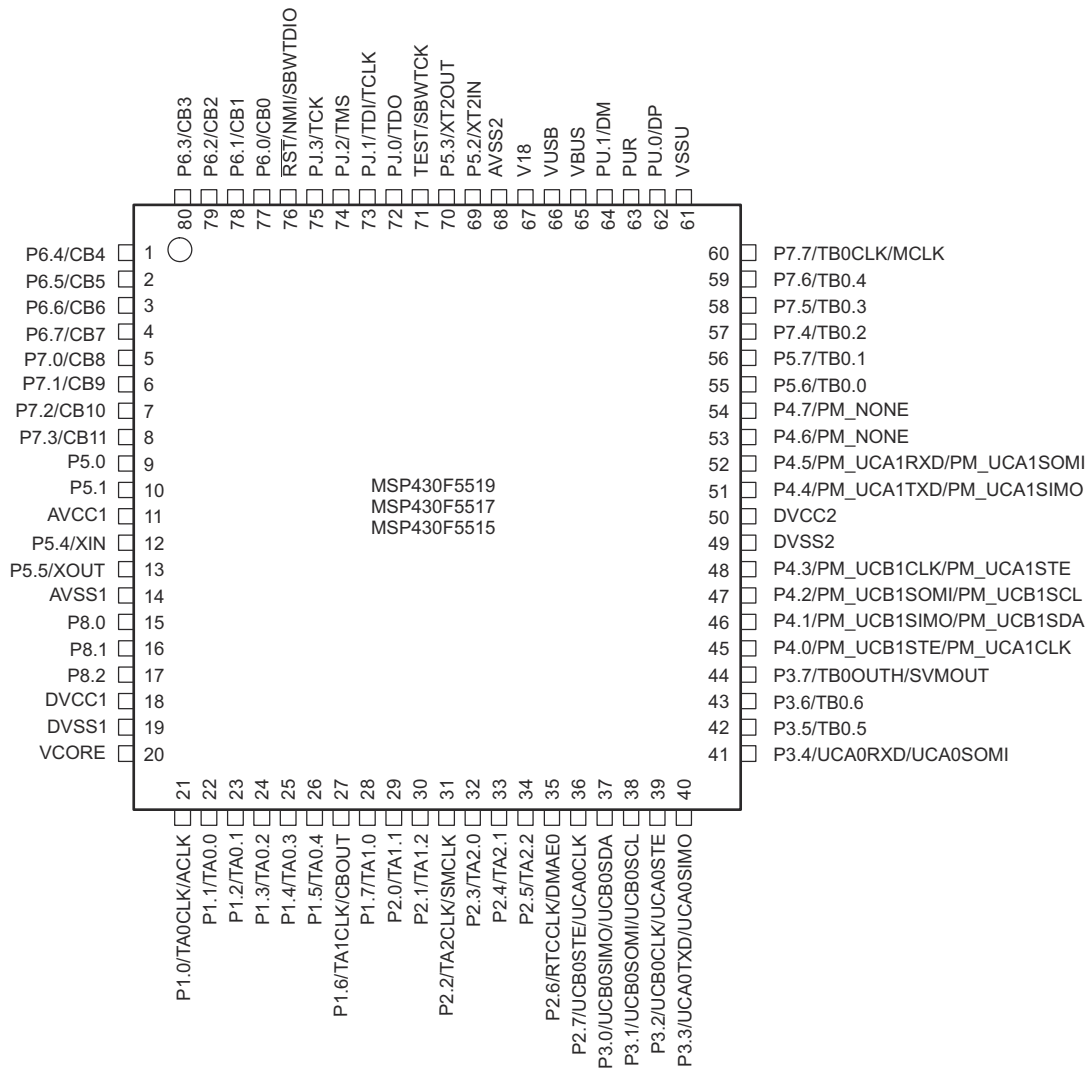
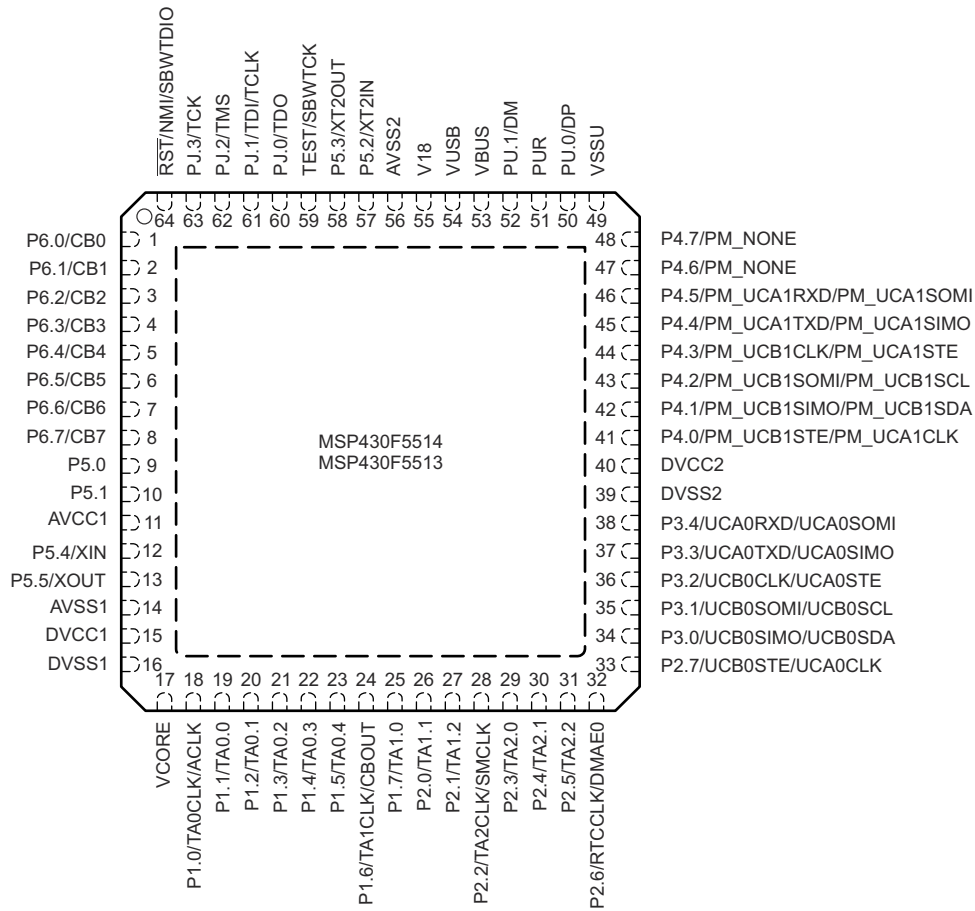

Figure 7-3. 80-Pin PN Package (Top View) – MSP430F5519IPN, MSP430F5517IPN, MSP430F5515IPN

Figure 7-4 shows the pinout for the MSP430F5514 and MSP430F5513 devices in the 64-pin RGC package.



TI recommends connecting the exposed thermal pad to V_{SS}.

Figure 7-4. 64-Pin RGC Package (Top View) – MSP430F5514IRGC, MSP430F5513IRGC

Figure 7-5 shows the pinout for the MSP430F5528, MSP430F5526, MSP430F5524, MSP430F5522, MSP430F5514, and MSP430F5513 devices in the 80-pin ZXH or ZQE package.

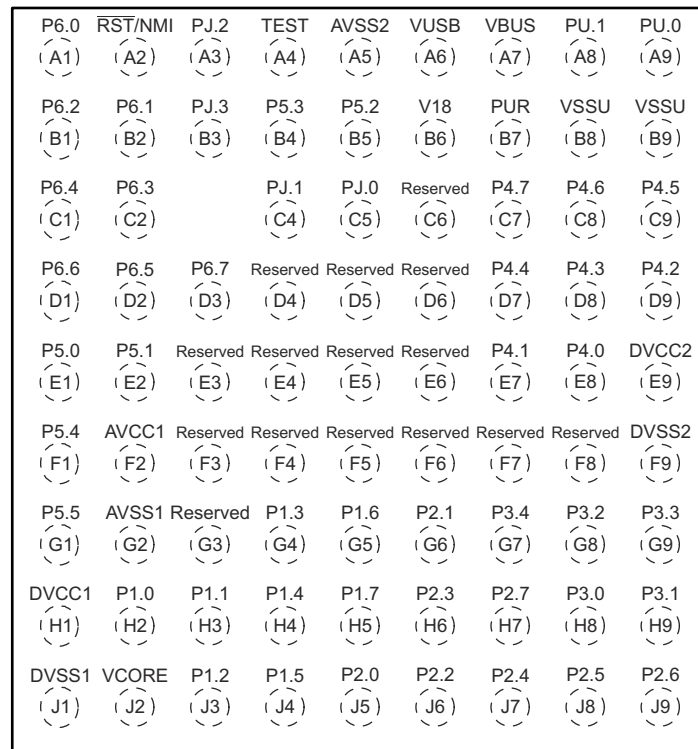

**Figure 7-5. 80-Pin ZXH or ZQE Package (Top View) –
MSP430F5528IZXH, MSP430F5526IZXH, MSP430F5524IZXH, MSP430F5522IZXH, MSP430F5514IZXH,
MSP430F5513IZXH,
MSP430F5528IZQE, MSP430F5526IZQE, MSP430F5524IZQE, MSP430F5522IZQE, MSP430F5514IZQE,
MSP430F5513IZQE**

Figure 7-6 shows the pinout for the MSP430F5528 device in the 64-pin YFF package. For package dimensions, see the *Mechanical Data* in Section 11.

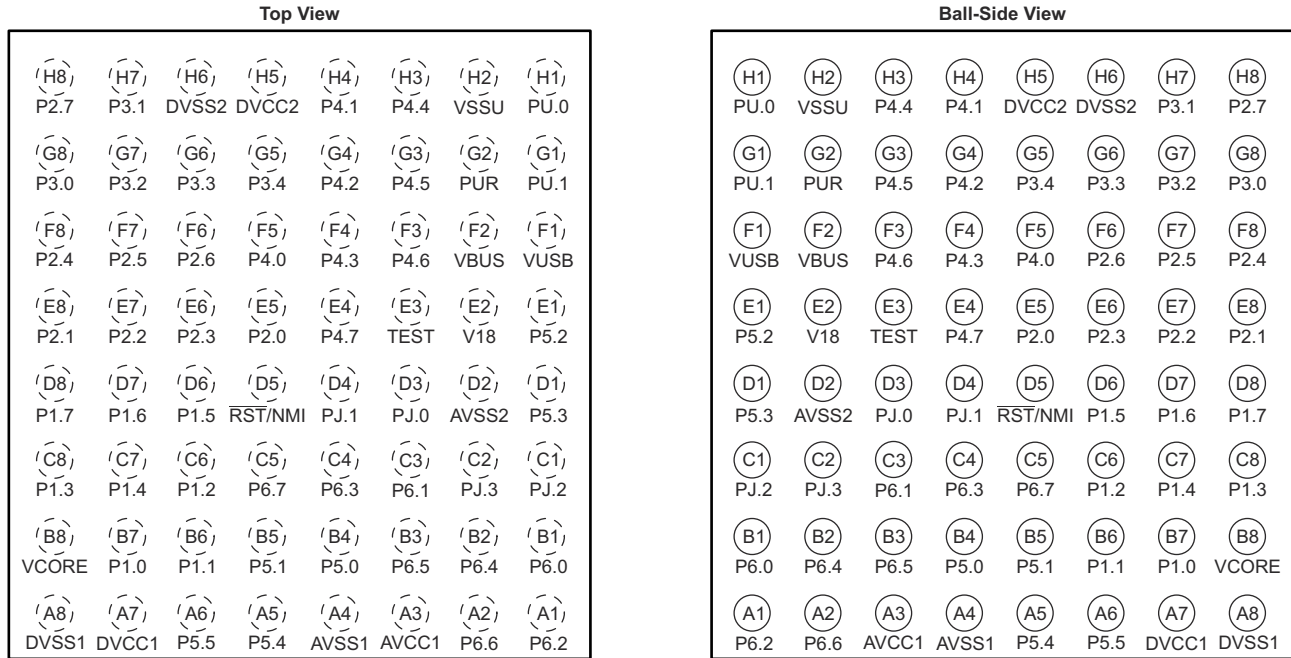

Figure 7-6. 64-Pin YFF Package – MSP430F5528IYFF

7.2 Signal Descriptions

Table 7-1 describes the signals for all device and package options.

Table 7-1. Terminal Functions

TERMINAL					I/O ⁽¹⁾	DESCRIPTION
NAME	NO.					
	PN	RGC	YFF	ZXH, ZQE		
P6.4/CB4/A4	1	5	B2	C1	I/O	General-purpose digital I/O Comparator_B input CB4 Analog input A4 for ADC (not available on F551x devices)
P6.5/CB5/A5	2	6	B3	D2	I/O	General-purpose digital I/O Comparator_B input CB5 Analog input A5 for ADC (not available on F551x devices)
P6.6/CB6/A6	3	7	A2	D1	I/O	General-purpose digital I/O Comparator_B input CB6 Analog input A6 for ADC (not available on F551x devices)
P6.7/CB7/A7	4	8	C5	D3	I/O	General-purpose digital I/O Comparator_B input CB7 Analog input A7 for ADC (not available on F551x devices)
P7.0/CB8/A12	5	N/A	N/A	N/A	I/O	General-purpose digital I/O (not available on F5528, F5526, F5524, F5522, F5514, F5513 devices) Comparator_B input CB8 (not available on F5528, F5526, F5524, F5522, F5514, F5513 devices) Analog input A12 for ADC (not available on F551x devices)
P7.1/CB9/A13	6	N/A	N/A	N/A	I/O	General-purpose digital I/O (not available on F5528, F5526, F5524, F5522, F5514, F5513 devices) Comparator_B input CB9 (not available on F5528, F5526, F5524, F5522, F5514, F5513 devices) Analog input A13 for ADC (not available on F551x devices)
P7.2/CB10/A14	7	N/A	N/A	N/A	I/O	General-purpose digital I/O (not available on F5528, F5526, F5524, F5522, F5514, F5513 devices) Comparator_B input CB10 (not available on F5528, F5526, F5524, F5522, F5514, F5513 devices) Analog input A14 for ADC (not available on F551x devices)
P7.3/CB11/A15	8	N/A	N/A	N/A	I/O	General-purpose digital I/O (not available on F5528, F5526, F5524, F5522, F5514, F5513 devices) Comparator_B input CB11 (not available on F5528, F5526, F5524, F5522, F5514, F5513 devices) Analog input A15 for ADC (not available on F551x devices)
P5.0/A8/VREF+/VeREF+	9	9	B4	E1	I/O	General-purpose digital I/O Output of reference voltage to the ADC (not available on F551x devices) Input for an external reference voltage to the ADC (not available on F551x devices) Analog input A8 for ADC (not available on F551x devices)
P5.1/A9/VREF-/VeREF-	10	10	B5	E2	I/O	General-purpose digital I/O Negative terminal for the ADC reference voltage for both sources, the internal reference voltage, or an external applied reference voltage (not available on F551x devices) Analog input A9 for ADC (not available on F551x devices)
AVCC1	11	11	A3	F2		Analog power supply

Table 7-1. Terminal Functions (continued)

TERMINAL					I/O ⁽¹⁾	DESCRIPTION
NAME	NO.					
	PN	RGC	YFF	ZXH, ZQE		
P5.4/XIN	12	12	A5	F1	I/O	General-purpose digital I/O Input terminal for crystal oscillator XT1
P5.5/XOUT	13	13	A6	G1	I/O	General-purpose digital I/O Output terminal of crystal oscillator XT1
AVSS1	14	14	A4	G2		Analog ground supply
P8.0	15	N/A	N/A	N/A	I/O	General-purpose digital I/O
P8.1	16	N/A	N/A	N/A	I/O	General-purpose digital I/O
P8.2	17	N/A	N/A	N/A	I/O	General-purpose digital I/O
DVCC1	18	15	A7	H1		Digital power supply
DVSS1	19	16	A8	J1		Digital ground supply
VCORE ⁽³⁾	20	17	B8	J2		Regulated core power supply output (internal use only, no external current loading)
P1.0/TA0CLK/ACLK	21	18	B7	H2	I/O	General-purpose digital I/O with port interrupt TA0 clock signal TA0CLK input ACLK output (divided by 1, 2, 4, 8, 16, or 32)
P1.1/TA0.0	22	19	B6	H3	I/O	General-purpose digital I/O with port interrupt TA0 CCR0 capture: CCI0A input, compare: Out0 output BSL transmit output
P1.2/TA0.1	23	20	C6	J3	I/O	General-purpose digital I/O with port interrupt TA0 CCR1 capture: CCI1A input, compare: Out1 output BSL receive input
P1.3/TA0.2	24	21	C8	G4	I/O	General-purpose digital I/O with port interrupt TA0 CCR2 capture: CCI2A input, compare: Out2 output
P1.4/TA0.3	25	22	C7	H4	I/O	General-purpose digital I/O with port interrupt TA0 CCR3 capture: CCI3A input compare: Out3 output
P1.5/TA0.4	26	23	D6	J4	I/O	General-purpose digital I/O with port interrupt TA0 CCR4 capture: CCI4A input, compare: Out4 output
P1.6/TA1CLK/CBOUT	27	24	D7	G5	I/O	General-purpose digital I/O with port interrupt TA1 clock signal TA1CLK input Comparator_B output
P1.7/TA1.0	28	25	D8	H5	I/O	General-purpose digital I/O with port interrupt TA1 CCR0 capture: CCI0A input, compare: Out0 output
P2.0/TA1.1	29	26	E5	J5	I/O	General-purpose digital I/O with port interrupt TA1 CCR1 capture: CCI1A input, compare: Out1 output
P2.1/TA1.2	30	27	E8	G6	I/O	General-purpose digital I/O with port interrupt TA1 CCR2 capture: CCI2A input, compare: Out2 output
P2.2/TA2CLK/SMCLK	31	28	E7	J6	I/O	General-purpose digital I/O with port interrupt TA2 clock signal TA2CLK input SMCLK output
P2.3/TA2.0	32	29	E6	H6	I/O	General-purpose digital I/O with port interrupt TA2 CCR0 capture: CCI0A input, compare: Out0 output
P2.4/TA2.1	33	30	F8	J7	I/O	General-purpose digital I/O with port interrupt TA2 CCR1 capture: CCI1A input, compare: Out1 output

Table 7-1. Terminal Functions (continued)

TERMINAL					I/O ⁽¹⁾	DESCRIPTION
NAME	NO.					
	PN	RGC	YFF	ZXH, ZQE		
P2.5/TA2.2	34	31	F7	J8	I/O	General-purpose digital I/O with port interrupt TA2 CCR2 capture: CCI2A input, compare: Out2 output
P2.6/RTCCLK/DMAE0	35	32	F6	J9	I/O	General-purpose digital I/O with port interrupt RTC clock output for calibration DMA external trigger input
P2.7/UCB0STE/UCA0CLK	36	33	H8	H7	I/O	General-purpose digital I/O with port interrupt Slave transmit enable – USCI_B0 SPI mode Clock signal input – USCI_A0 SPI slave mode Clock signal output – USCI_A0 SPI master mode
P3.0/UCB0SIMO/ UCB0SDA	37	34	G8	H8	I/O	General-purpose digital I/O Slave in, master out – USCI_B0 SPI mode I ² C data – USCI_B0 I ² C mode
P3.1/UCB0SOMI/ UCB0SCL	38	35	H7	H9	I/O	General-purpose digital I/O Slave out, master in – USCI_B0 SPI mode I ² C clock – USCI_B0 I ² C mode
P3.2/UCB0CLK/UCA0STE	39	36	G7	G8	I/O	General-purpose digital I/O Clock signal input – USCI_B0 SPI slave mode Clock signal output – USCI_B0 SPI master mode Slave transmit enable – USCI_A0 SPI mode
P3.3/UCA0TXD/ UCA0SIMO	40	37	G6	G9	I/O	General-purpose digital I/O Transmit data – USCI_A0 UART mode Slave in, master out – USCI_A0 SPI mode
P3.4/UCA0RXD/ UCA0SOMI	41	38	G5	G7	I/O	General-purpose digital I/O Receive data – USCI_A0 UART mode Slave out, master in – USCI_A0 SPI mode
P3.5/TB0.5	42	N/A	N/A	N/A	I/O	General-purpose digital I/O (not available on F5528, F5526, F5524, F5522, F5514, F5513 devices) TB0 CCR5 capture: CCI5A input, compare: Out5 output
P3.6/TB0.6	43	N/A	N/A	N/A	I/O	General-purpose digital I/O (not available on F5528, F5526, F5524, F5522, F5514, F5513 devices) TB0 CCR6 capture: CCI6A input, compare: Out6 output
P3.7/TB0OUTH/SVMOUT	44	N/A	N/A	N/A	I/O	General-purpose digital I/O (not available on F5528, F5526, F5524, F5522, F5514, F5513 devices) Switch all PWM outputs high impedance input – TB0 (not available on F5528, F5526, F5524, F5522, F5514, F5513 devices) SVM output (not available on F5528, F5526, F5524, F5522, F5514, F5513 devices)
P4.0/PM_UCB1STE/ PM_UCA1CLK	45	41	F5	E8	I/O	General-purpose digital I/O with reconfigurable port mapping secondary function Default mapping: Slave transmit enable – USCI_B1 SPI mode Default mapping: Clock signal input – USCI_A1 SPI slave mode Default mapping: Clock signal output – USCI_A1 SPI master mode
P4.1/PM_UCB1SIMO/ PM_UCB1SDA	46	42	H4	E7	I/O	General-purpose digital I/O with reconfigurable port mapping secondary function Default mapping: Slave in, master out – USCI_B1 SPI mode Default mapping: I ² C data – USCI_B1 I ² C mode

Table 7-1. Terminal Functions (continued)

TERMINAL					I/O ⁽¹⁾	DESCRIPTION
NAME	NO.					
	PN	RGC	YFF	ZXH, ZQE		
P4.2/PM_UCB1SOMI/ PM_UCB1SCL	47	43	G4	D9	I/O	General-purpose digital I/O with reconfigurable port mapping secondary function Default mapping: Slave out, master in – USCI_B1 SPI mode Default mapping: I ² C clock – USCI_B1 I ² C mode
P4.3/PM_UCB1CLK/ PM_UCA1STE	48	44	F4	D8	I/O	General-purpose digital I/O with reconfigurable port mapping secondary function Default mapping: Clock signal input – USCI_B1 SPI slave mode Default mapping: Clock signal output – USCI_B1 SPI master mode Default mapping: Slave transmit enable – USCI_A1 SPI mode
DVSS2	49	39	H6	F9		Digital ground supply
DVCC2	50	40	H5	E9		Digital power supply
P4.4/PM_UCA1TXD/ PM_UCA1SIMO	51	45	H3	D7	I/O	General-purpose digital I/O with reconfigurable port mapping secondary function Default mapping: Transmit data – USCI_A1 UART mode Default mapping: Slave in, master out – USCI_A1 SPI mode
P4.5/PM_UCA1RXD/ PM_UCA1SOMI	52	46	G3	C9	I/O	General-purpose digital I/O with reconfigurable port mapping secondary function Default mapping: Receive data – USCI_A1 UART mode Default mapping: Slave out, master in – USCI_A1 SPI mode
P4.6/PM_NONE	53	47	F3	C8	I/O	General-purpose digital I/O with reconfigurable port mapping secondary function Default mapping: no secondary function.
P4.7/PM_NONE	54	48	E4	C7	I/O	General-purpose digital I/O with reconfigurable port mapping secondary function Default mapping: no secondary function.
P5.6/TB0.0	55	N/A	N/A	N/A	I/O	General-purpose digital I/O (not available on F5528, F5526, F5524, F5522, F5514, F5513 devices) TB0 CCR0 capture: CCI0A input, compare: Out0 output (not available on F5528, F5526, F5524, F5522, F5514, F5513 devices)
P5.7/TB0.1	56	N/A	N/A	N/A	I/O	General-purpose digital I/O (not available on F5528, F5526, F5524, F5522, F5514, F5513 devices) TB0 CCR1 capture: CCI1A input, compare: Out1 output (not available on F5528, F5526, F5524, F5522, F5514, F5513 devices)
P7.4/TB0.2	57	N/A	N/A	N/A	I/O	General-purpose digital I/O (not available on F5528, F5526, F5524, F5522, F5514, F5513 devices) TB0 CCR2 capture: CCI2A input, compare: Out2 output (not available on F5528, F5526, F5524, F5522, F5514, F5513 devices)
P7.5/TB0.3	58	N/A	N/A	N/A	I/O	General-purpose digital I/O (not available on F5528, F5526, F5524, F5522, F5514, F5513 devices) TB0 CCR3 capture: CCI3A input, compare: Out3 output (not available on F5528, F5526, F5524, F5522, F5514, F5513 devices)
P7.6/TB0.4	59	N/A	N/A	N/A	I/O	General-purpose digital I/O (not available on F5528, F5526, F5524, F5522, F5514, F5513 devices) TB0 CCR4 capture: CCI4A input, compare: Out4 output (not available on F5528, F5526, F5524, F5522, F5514, F5513 devices)
P7.7/TB0CLK/MCLK	60	N/A	N/A	N/A	I/O	General-purpose digital I/O (not available on F5528, F5526, F5524, F5522, F5514, F5513 devices)

Table 7-1. Terminal Functions (continued)

TERMINAL					I/O ⁽¹⁾	DESCRIPTION
NAME	NO.					
	PN	RGC	YFF	ZXH, ZQE		
						TB0 clock signal TBCLK input (not available on F5528, F5526, F5524, F5522, F5514, F5513 devices) MCLK output (not available on F5528, F5526, F5524, F5522, F5514, F5513 devices)
VSSU	61	49	H2	B8, B9		USB PHY ground supply
PU.0/DP	62	50	H1	A9	I/O	General-purpose digital I/O. Controlled by USB control register USB data terminal DP
PUR	63	51	G2	B7	I/O	USB pullup resistor pin (open drain). The voltage level at the PUR pin is used to invoke the default USB BSL. Recommended 1-MΩ resistor to ground. See Section 9.5.1 for more information.
PU.1/DM	64	52	G1	A8	I/O	General-purpose digital I/O. Controlled by USB control register USB data terminal DM
VBUS	65	53	F2	A7		USB LDO input (connect to USB power source)
VUSB	66	54	F1	A6		USB LDO output
V18	67	55	E2	B6		USB regulated power (internal use only, no external current loading)
AVSS2	68	56	D2	A5		Analog ground supply
P5.2/XT2IN	69	57	E1	B5	I/O	General-purpose digital I/O Input terminal for crystal oscillator XT2
P5.3/XT2OUT	70	58	D1	B4	I/O	General-purpose digital I/O Output terminal of crystal oscillator XT2
TEST/SBWTCK ⁽⁴⁾	71	59	E3	A4	I	Test mode pin – selects 4-wire JTAG operation Spy-Bi-Wire input clock when Spy-Bi-Wire operation activated
PJ.0/TDO ⁽⁵⁾	72	60	D3	C5	I/O	General-purpose digital I/O JTAG test data output port
PJ.1/TDI/TCLK ⁽⁵⁾	73	61	D4	C4	I/O	General-purpose digital I/O JTAG test data input Test clock input
PJ.2/TMS ⁽⁵⁾	74	62	C1	A3	I/O	General-purpose digital I/O JTAG test mode select
PJ.3/TCK ⁽⁵⁾	75	63	C2	B3	I/O	General-purpose digital I/O JTAG test clock
RST/NMI/SBWDIO ⁽⁴⁾	76	64	D5	A2	I/O	Reset input, active low ⁽⁶⁾ Nonmaskable interrupt input Spy-Bi-Wire data input/output when Spy-Bi-Wire operation activated
P6.0/CB0/A0	77	1	B1	A1	I/O	General-purpose digital I/O Comparator_B input CB0 Analog input A0 for ADC (not available on F551x devices)
P6.1/CB1/A1	78	2	C3	B2	I/O	General-purpose digital I/O Comparator_B input CB1 Analog input A1 for ADC (not available on F551x devices)
P6.2/CB2/A2	79	3	A1	B1	I/O	General-purpose digital I/O Comparator_B input CB2 Analog input A2 for ADC (not available on F551x devices)
P6.3/CB3/A3	80	4	C4	C2	I/O	General-purpose digital I/O Comparator_B input CB3

Table 7-1. Terminal Functions (continued)

TERMINAL					I/O ⁽¹⁾	DESCRIPTION
NAME	NO.					
	PN	RGC	YFF	ZXH, ZQE		
						Analog input A3 for ADC (not available on F551x devices)
Reserved	N/A	N/A	N/A	(2)		Reserved. Connect to ground.
QFN Pad	N/A	Pad	N/A	N/A		QFN package pad. TI recommends connecting to V _{SS} .

(1) I = input, O = output, N/A = not available

(2) C6, D4, D5, D6, E3, E4, E5, E6, F3, F4, F5, F6, F7, F8, G3 are reserved and should be connected to ground.

(3) V_{CORE} is for internal use only. No external current loading is possible. Connect V_{CORE} to the recommended capacitor value, C_{V_{CORE}} (see [Section 8.3](#)).

(4) See [Section 9.5](#) and [Section 9.6](#) for use with BSL and JTAG functions.

(5) See [Section 9.6](#) for use with JTAG function.

(6) When this pin is configured as reset, the internal pullup resistor is enabled by default.

8 Specifications

All graphs in this section are for typical conditions, unless otherwise noted.

Typical (TYP) values are specified at $V_{CC} = 3.3\text{ V}$ and $T_A = 25^\circ\text{C}$, unless otherwise noted.

8.1 Absolute Maximum Ratings

over operating free-air temperature range (unless otherwise noted)⁽¹⁾

	MIN	MAX	UNIT
Voltage applied at V_{CC} to V_{SS}	-0.3	4.1	V
Voltage applied to any pin (excluding V _{CORE} , V _{BUS} , V18) ⁽²⁾	-0.3	$V_{CC} + 0.3$	V
Diode current at any device pin		±2	mA
Maximum operating junction temperature, T_J		95	°C
Storage temperature, T_{stg} ⁽³⁾	-55	150	°C

- (1) Stresses beyond those listed under *Absolute Maximum Ratings* may cause permanent damage to the device. These are stress ratings only, and functional operation of the device at these or any other conditions beyond those indicated under *Recommended Operating Conditions* is not implied. Exposure to absolute-maximum-rated conditions for extended periods may affect device reliability.
- (2) All voltages referenced to V_{SS} . V_{CORE} is for internal device use only. No external DC loading or voltage should be applied.
- (3) Higher temperature may be applied during board soldering according to the current JEDEC J-STD-020 specification with peak reflow temperatures not higher than classified on the device label on the shipping boxes or reels.

8.2 ESD Ratings

		VALUE	UNIT
$V_{(ESD)}$ Electrostatic discharge	Human-body model (HBM), per ANSI/ESDA/JEDEC JS-001 ⁽¹⁾	±1000	V
	Charged-device model (CDM), per JEDEC specification JESD22-C101 ⁽²⁾	±250	

- (1) JEDEC document JEP155 states that 500-V HBM allows safe manufacturing with a standard ESD control process. Pins listed as ±1000 V may actually have higher performance.
- (2) JEDEC document JEP157 states that 250-V CDM allows safe manufacturing with a standard ESD control process. Pins listed as ±250 V may actually have higher performance.

8.3 Recommended Operating Conditions

		MIN	NOM	MAX	UNIT
V _{CC}	Supply voltage during program execution and flash programming (AV _{CC} = DV _{CC1} = DV _{CC2} = DV _{CC}) ⁽¹⁾ ⁽²⁾	PMMCOREV _x = 0	1.8	3.6	V
		PMMCOREV _x = 0, 1	2.0	3.6	
		PMMCOREV _x = 0, 1, 2	2.2	3.6	
		PMMCOREV _x = 0, 1, 2, 3	2.4	3.6	
V _{CC, USB}	Supply voltage during USB operation, USB PLL disabled, USB_EN = 1, UPLLEN = 0	PMMCOREV _x = 0	1.8	3.6	V
		PMMCOREV _x = 0, 1	2.0	3.6	
		PMMCOREV _x = 0, 1, 2	2.2	3.6	
		PMMCOREV _x = 0, 1, 2, 3	2.4	3.6	
	Supply voltage during USB operation, USB PLL enabled ⁽³⁾ , USB_EN = 1, UPLLEN = 1	PMMCOREV _x = 2	2.2	3.6	
		PMMCOREV _x = 2, 3	2.4	3.6	
V _{SS}	Supply voltage (AV _{SS} = DV _{SS1} = DV _{SS2} = DV _{SS})		0		V
T _A	Operating free-air temperature	I version	-40	85	°C
T _J	Operating junction temperature	I version	-40	85	°C
C _{VCORE}	Recommended capacitor at V _{CORE} ⁽⁴⁾		470		nF
C _{DVCC} / C _{VCORE}	Capacitor ratio of DV _{CC} to V _{CORE}		10		ratio
f _{SYSTEM}	Processor frequency (maximum MCLK frequency) ⁽⁵⁾ (see Figure 8-1)	PMMCOREV _x = 0, 1.8 V ≤ V _{CC} ≤ 3.6 V (default condition)	0	8.0	MHz
		PMMCOREV _x = 1, 2.0 V ≤ V _{CC} ≤ 3.6 V	0	12.0	
		PMMCOREV _x = 2, 2.2 V ≤ V _{CC} ≤ 3.6 V	0	20.0	
		PMMCOREV _x = 3, 2.4 V ≤ V _{CC} ≤ 3.6 V	0	25.0	
f _{SYSTEM_USB}	Minimum processor frequency for USB operation		1.5		MHz
USB_wait	Wait state cycles during USB operation		16		cycles

- (1) TI recommends powering AV_{CC} and DV_{CC} from the same source. A maximum difference of 0.3 V between AV_{CC} and DV_{CC} can be tolerated during power up and operation.
- (2) The minimum supply voltage is defined by the supervisor SVS levels when it is enabled. See the [Section 8.22](#) threshold parameters for the exact values and further details.
- (3) USB operation with USB PLL enabled requires PMMCOREV_x ≥ 2 for proper operation.
- (4) A capacitor tolerance of ±20% or better is required.
- (5) Modules may have a different maximum input clock specification. See the specification of the respective module in this data sheet.

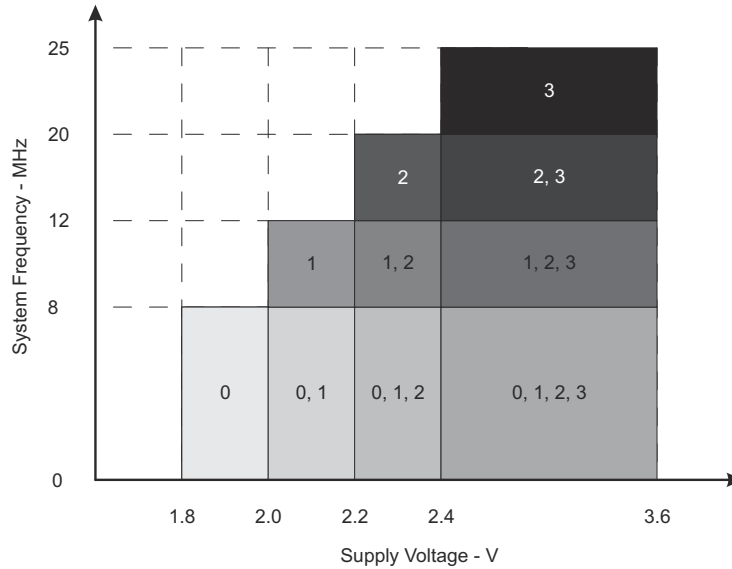

NOTE: The numbers within the fields denote the supported PMMCOEVx settings.

Figure 8-1. Maximum System Frequency

8.4 Active Mode Supply Current Into V_{CC} Excluding External Current

over recommended operating free-air temperature (unless otherwise noted)^{(1) (2) (3)}

PARAMETER	EXECUTION MEMORY	V_{CC}	PMMCOEVx	FREQUENCY ($f_{DCO} = f_{MCLK} = f_{SMCLK}$)								UNIT		
				1 MHz		8 MHz		12 MHz		20 MHz			25 MHz	
				TYP	MAX	TYP	MAX	TYP	MAX	TYP	MAX		TYP	MAX
$I_{AM, Flash}$	Flash	3.0 V	0	0.36	0.47	2.32	2.60							mA
			1	0.40		2.65		4.0	4.4					
			2	0.44		2.90		4.3		7.1	7.7			
			3	0.46		3.10		4.6		7.6		10.1	11.0	
$I_{AM, RAM}$	RAM	3.0 V	0	0.20	0.24	1.20	1.30							mA
			1	0.22		1.35		2.0	2.2					
			2	0.24		1.50		2.2		3.7	4.2			
			3	0.26		1.60		2.4		3.9		5.3	6.2	

- (1) All inputs are tied to 0 V or to V_{CC} . Outputs do not source or sink any current.
- (2) The currents are characterized with a Micro Crystal MS1V-T1K crystal with a load capacitance of 12.5 pF. The internal and external load capacitance are chosen to closely match the required 12.5 pF.
- (3) Characterized with program executing typical data processing. USB disabled ($V_{USBEN} = 0$, $SLDOEN = 0$).
 $f_{ACLK} = 32786$ Hz, $f_{DCO} = f_{MCLK} = f_{SMCLK}$ at specified frequency.
 $XTS = CPUOFF = SCG0 = SCG1 = OSCOFF = SMCLKOFF = 0$.

8.5 Low-Power Mode Supply Currents (Into V_{CC}) Excluding External Current

over recommended ranges of supply voltage and operating free-air temperature (unless otherwise noted)^{(1) (2)}

PARAMETER	V_{CC}	PMMCOREVx	-40°C		25°C		60°C		85°C		UNIT
			TYP	MAX	TYP	MAX	TYP	MAX	TYP	MAX	
$I_{LPM0,1MHz}$ Low-power mode 0 ^{(3) (4)}	2.2 V	0	73		77	85	80		85	97	μA
	3.0 V	3	79		83	92	88		95	105	
I_{LPM2} Low-power mode 2 ^{(5) (4)}	2.2 V	0	6.5		6.5	12	10		11	17	μA
	3.0 V	3	7.0		7.0	13	11		12	18	
$I_{LPM3,XT1LF}$ Low-power mode 3, crystal mode ^{(6) (4)}	2.2 V	0	1.60		1.90		2.6		5.6		μA
		1	1.65		2.00		2.7		5.9		
		2	1.75		2.15		2.9		6.1		
	3.0 V	0	1.8		2.1	2.9	2.8		5.8	8.3	
		1	1.9		2.3		2.9		6.1		
		2	2.0		2.4		3.0		6.3		
$I_{LPM3,VLO}$ Low-power mode 3, VLO mode ^{(7) (4)}	3.0 V	0	1.1		1.4	2.7	1.9		4.9	7.4	μA
		1	1.1		1.4		2.0		5.2		
		2	1.2		1.5		2.1		5.3		
		3	1.3		1.6	3.0	2.2		5.4	8.5	
I_{LPM4} Low-power mode 4 ^{(8) (4)}	3.0 V	0	0.9		1.1	1.5	1.8		4.8	7.3	μA
		1	1.1		1.2		2.0		5.1		
		2	1.2		1.2		2.1		5.2		
		3	1.3		1.3	1.6	2.2		5.3	8.1	
$I_{LPM4.5}$ Low-power mode 4.5 ⁽⁹⁾	3.0 V	—	0.15		0.18	0.35	0.26		0.5	1.0	μA

- (1) All inputs are tied to 0 V or to V_{CC} . Outputs do not source or sink any current.
- (2) The currents are characterized with a Micro Crystal MS1V-T1K crystal with a load capacitance of 12.5 pF. The internal and external load capacitance are chosen to closely match the required 12.5 pF.
- (3) Current for watchdog timer clocked by SMCLK included. ACLK = low frequency crystal operation (XTS = 0, XT1DRIVE_x = 0). CPUOFF = 1, SCG0 = 0, SCG1 = 0, OSCOFF = 0 (LPM0); f_{ACLK} = 32768 Hz, f_{MCLK} = 0 MHz, f_{SMCLK} = f_{DCO} = 1 MHz
USB disabled (VUSBEN = 0, SLDOEN = 0).
- (4) Current for brownout, high-side supervisor (SVSH) normal mode included. Low-side supervisor and monitor disabled (SVSL, SVM_L). High-side monitor disabled (SVM_H). RAM retention enabled.
- (5) Current for watchdog timer and RTC clocked by ACLK included. ACLK = low frequency crystal operation (XTS = 0, XT1DRIVE_x = 0). CPUOFF = 1, SCG0 = 0, SCG1 = 1, OSCOFF = 0 (LPM2); f_{ACLK} = 32768 Hz, f_{MCLK} = 0 MHz, f_{SMCLK} = f_{DCO} = 0 MHz; DCO setting = 1 MHz operation, DCO bias generator enabled.
USB disabled (VUSBEN = 0, SLDOEN = 0)
- (6) Current for watchdog timer and RTC clocked by ACLK included. ACLK = low frequency crystal operation (XTS = 0, XT1DRIVE_x = 0). CPUOFF = 1, SCG0 = 1, SCG1 = 1, OSCOFF = 0 (LPM3); f_{ACLK} = 32768 Hz, f_{MCLK} = f_{SMCLK} = f_{DCO} = 0 MHz
USB disabled (VUSBEN = 0, SLDOEN = 0)
- (7) Current for watchdog timer and RTC clocked by ACLK included. ACLK = VLO.
CPUOFF = 1, SCG0 = 1, SCG1 = 1, OSCOFF = 0 (LPM3); f_{ACLK} = f_{VLO} , f_{MCLK} = f_{SMCLK} = f_{DCO} = 0 MHz
USB disabled (VUSBEN = 0, SLDOEN = 0)
- (8) CPUOFF = 1, SCG0 = 1, SCG1 = 1, OSCOFF = 1 (LPM4); f_{DCO} = f_{ACLK} = f_{MCLK} = f_{SMCLK} = 0 MHz
USB disabled (VUSBEN = 0, SLDOEN = 0)
- (9) Internal regulator disabled. No data retention.
CPUOFF = 1, SCG0 = 1, SCG1 = 1, OSCOFF = 1, PMMREGOFF = 1 (LPM4.5); f_{DCO} = f_{ACLK} = f_{MCLK} = f_{SMCLK} = 0 MHz

8.6 Thermal Resistance Characteristics

THERMAL METRIC ⁽¹⁾			VALUE	UNIT	
R θ_{JA}	Junction-to-ambient thermal resistance, still air	Low-K board (JESD51-3)	LQFP (PN)	70	°C/W
			VQFN (RGC)	55	
			BGA (ZQE)	84	
		High-K board (JESD51-7)	LQFP (PN)	45	
			VQFN (RGC)	25	
			BGA (ZQE)	46	
R θ_{JC}	Junction-to-case thermal resistance	LQFP (PN)	12	°C/W	
		VQFN (RGC)	12		
		BGA (ZQE)	30		
R θ_{JB}	Junction-to-board thermal resistance	LQFP (PN)	22	°C/W	
		VQFN (RGC)	6		
		BGA (ZQE)	20		

(1) For more information about traditional and new thermal metrics, see the [Semiconductor and IC Package Thermal Metrics](#) application report.

8.7 Schmitt-Trigger Inputs – General-Purpose I/O (P1.0 to P1.7, P2.0 to P2.7, P3.0 to P3.7, P4.0 to P4.7, P5.0 to P5.7, P6.0 to P6.7, P7.0 to P7.7, P8.0 to P8.2, PJ.0 to PJ.3, \overline{RST}/NMI)

over recommended ranges of supply voltage and operating free-air temperature (unless otherwise noted)

PARAMETER ⁽¹⁾	TEST CONDITIONS	V _{CC}	MIN	TYP	MAX	UNIT
V _{IT+}	Positive-going input threshold voltage	1.8 V	0.80		1.40	V
		3 V	1.50		2.10	
V _{IT-}	Negative-going input threshold voltage	1.8 V	0.45		1.00	V
		3 V	0.75		1.65	
V _{hys}	Input voltage hysteresis (V _{IT+} – V _{IT-})	1.8 V	0.3		0.85	V
		3 V	0.4		1.0	
R _{Pull}	Pullup and pulldown resistor ⁽²⁾	For pullup: V _{IN} = V _{SS} For pulldown: V _{IN} = V _{CC}	20	35	50	k Ω
C _I	Input capacitance	V _{IN} = V _{SS} or V _{CC}		5		pF

(1) Same parametrics apply to clock input pin when the crystal bypass mode is used on XT1 (XIN) or XT2 (XT2IN).

(2) Also applies to \overline{RST} pin when pullup or pulldown resistor is enabled.

8.8 Inputs – Ports P1 and P2 (P1.0 to P1.7, P2.0 to P2.7)

over recommended ranges of supply voltage and operating free-air temperature (unless otherwise noted)

PARAMETER ⁽¹⁾	TEST CONDITIONS	V _{CC}	MIN	MAX	UNIT
t _(int)	External interrupt timing ⁽²⁾	External trigger pulse duration to set interrupt flag	2.2 V, 3 V	20	ns

(1) Some devices may contain additional ports with interrupts. See the block diagram and terminal function descriptions.

(2) An external signal sets the interrupt flag every time the minimum interrupt pulse duration t_(int) is met. It may be set by trigger signals shorter than t_(int).

8.9 Leakage Current – General-Purpose I/O

(P1.0 to P1.7, P2.0 to P2.7, P3.0 to P3.7, P4.0 to P4.7)

(P5.0 to P5.7, P6.0 to P6.7, P7.0 to P7.7, P8.0 to P8.2, PJ.0 to PJ.3, $\overline{\text{RST/NMI}}$)

over recommended ranges of supply voltage and operating free-air temperature (unless otherwise noted)

PARAMETER		TEST CONDITIONS	V _{CC}	MIN	MAX	UNIT
I _{kg(Px.y)}	High-impedance leakage current	See (1) (2)	1.8 V, 3 V	-50	50	nA

(1) The leakage current is measured with V_{SS} or V_{CC} applied to the corresponding pin(s), unless otherwise noted.

(2) The leakage of the digital port pins is measured individually. The port pin is selected for input and the pullup or pulldown resistor is disabled.

8.10 Outputs – General-Purpose I/O (Full Drive Strength)

(P1.0 to P1.7, P2.0 to P2.7, P3.0 to P3.7, P4.0 to P4.7,

P5.0 to P5.7, P6.0 to P6.7, P7.0 to P7.7, P8.0 to P8.2, PJ.0 to PJ.3)

over recommended ranges of supply voltage and operating free-air temperature (unless otherwise noted)

PARAMETER		TEST CONDITIONS	V _{CC}	MIN	MAX	UNIT
V _{OH}	High-level output voltage (see Figure 8-8 and Figure 8-9)	I _(OHmax) = -3 mA ⁽¹⁾	1.8 V	V _{CC} - 0.25	V _{CC}	V
		I _(OHmax) = -10 mA ⁽²⁾		V _{CC} - 0.60	V _{CC}	
		I _(OHmax) = -5 mA ⁽¹⁾	3 V	V _{CC} - 0.25	V _{CC}	
		I _(OHmax) = -15 mA ⁽²⁾		V _{CC} - 0.60	V _{CC}	
V _{OL}	Low-level output voltage (see Figure 8-6 and Figure 8-7)	I _(OLmax) = 3 mA ⁽¹⁾	1.8 V	V _{SS}	V _{SS} + 0.25	V
		I _(OLmax) = 10 mA ⁽²⁾		V _{SS}	V _{SS} + 0.60	
		I _(OLmax) = 5 mA ⁽¹⁾	3 V	V _{SS}	V _{SS} + 0.25	
		I _(OLmax) = 15 mA ⁽²⁾		V _{SS}	V _{SS} + 0.60	

(1) The maximum total current, I_(OHmax) and I_(OLmax), for all outputs combined should not exceed ±48 mA to hold the maximum voltage drop specified.

(2) The maximum total current, I_(OHmax) and I_(OLmax), for all outputs combined should not exceed ±100 mA to hold the maximum voltage drop specified.

8.11 Outputs – General-Purpose I/O (Reduced Drive Strength)

(P1.0 to P1.7, P2.0 to P2.7, P3.0 to P3.7, P4.0 to P4.7,

P5.0 to P5.7, P6.0 to P6.7, P7.0 to P7.7, P8.0 to P8.2, PJ.0 to PJ.3)

over recommended ranges of supply voltage and operating free-air temperature (unless otherwise noted)⁽³⁾

PARAMETER		TEST CONDITIONS	V _{CC}	MIN	MAX	UNIT
V _{OH}	High-level output voltage (see Figure 8-4 and Figure 8-5)	I _(OHmax) = -1 mA ⁽¹⁾	1.8 V	V _{CC} - 0.25	V _{CC}	V
		I _(OHmax) = -3 mA ⁽²⁾		V _{CC} - 0.60	V _{CC}	
		I _(OHmax) = -2 mA ⁽¹⁾	3.0 V	V _{CC} - 0.25	V _{CC}	
		I _(OHmax) = -6 mA ⁽²⁾		V _{CC} - 0.60	V _{CC}	
V _{OL}	Low-level output voltage (see Figure 8-2 and Figure 8-3)	I _(OLmax) = 1 mA ⁽¹⁾	1.8 V	V _{SS}	V _{SS} + 0.25	V
		I _(OLmax) = 3 mA ⁽²⁾		V _{SS}	V _{SS} + 0.60	
		I _(OLmax) = 2 mA ⁽¹⁾	3.0 V	V _{SS}	V _{SS} + 0.25	
		I _(OLmax) = 6 mA ⁽²⁾		V _{SS}	V _{SS} + 0.60	

(1) The maximum total current, I_(OHmax) and I_(OLmax), for all outputs combined, should not exceed ±48 mA to hold the maximum voltage drop specified.

(2) The maximum total current, I_(OHmax) and I_(OLmax), for all outputs combined, should not exceed ±100 mA to hold the maximum voltage drop specified.

(3) Selecting reduced drive strength may reduce EMI.

8.12 Output Frequency – General-Purpose I/O (P1.0 to P1.7, P2.0 to P2.7, P3.0 to P3.7, P4.0 to P4.7, P5.0 to P5.7, P6.0 to P6.7, P7.0 to P7.7, P8.0 to P8.2, PJ.0 to PJ.3)

over recommended ranges of supply voltage and operating free-air temperature (unless otherwise noted)

PARAMETER		TEST CONDITIONS	MIN	MAX	UNIT
f _{Px.y}	Port output frequency (with load)	See (1) (2)	V _{CC} = 1.8 V, PMMCOREV _x = 0	16	MHz
			V _{CC} = 3 V, PMMCOREV _x = 3	25	
f _{Port_CLK}	Clock output frequency	ACLK, SMCLK, MCLK, C _L = 20 pF ⁽²⁾	V _{CC} = 1.8 V, PMMCOREV _x = 0	16	MHz
			V _{CC} = 3 V, PMMCOREV _x = 3	25	

- (1) A resistive divider with 2 × R1 between V_{CC} and V_{SS} is used as load. The output is connected to the center tap of the divider. For full drive strength, R1 = 550 Ω. For reduced drive strength, R1 = 1.6 kΩ. C_L = 20 pF is connected to the output to V_{SS}.
- (2) The output voltage reaches at least 10% and 90% V_{CC} at the specified toggle frequency.

8.13 Typical Characteristics – Outputs, Reduced Drive Strength (PxDS.y = 0)

over recommended ranges of supply voltage and operating free-air temperature (unless otherwise noted)

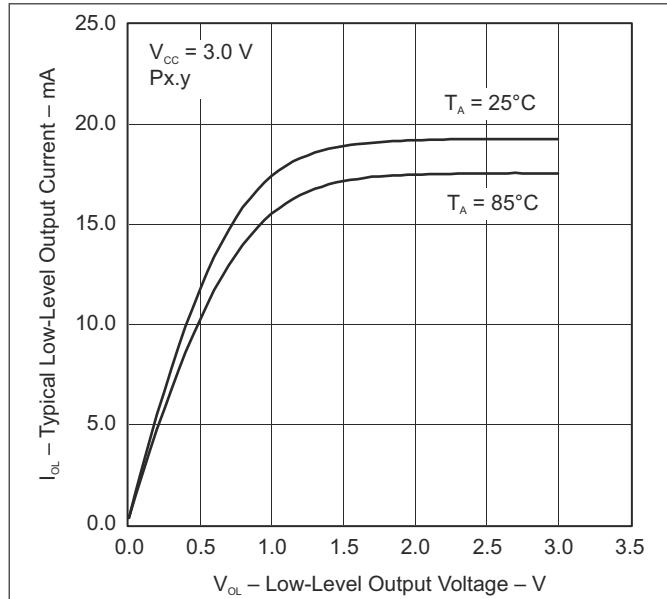

Figure 8-2. Typical Low-Level Output Current vs Low-Level Output Voltage

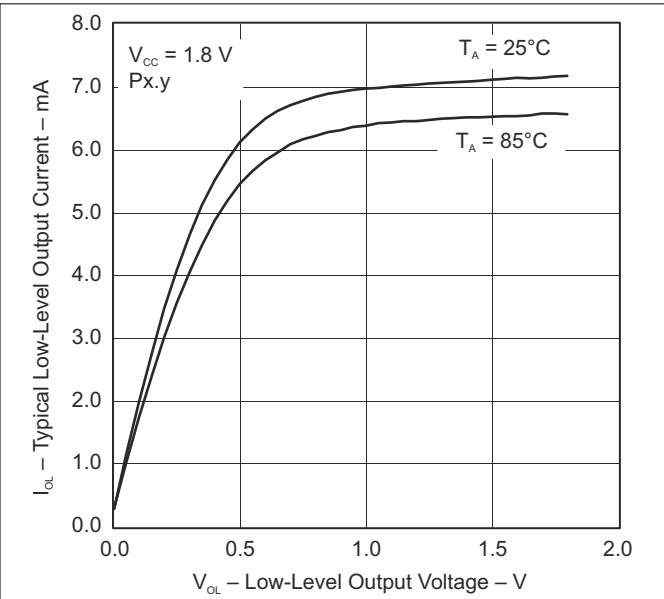

Figure 8-3. Typical Low-Level Output Current vs Low-Level Output Voltage

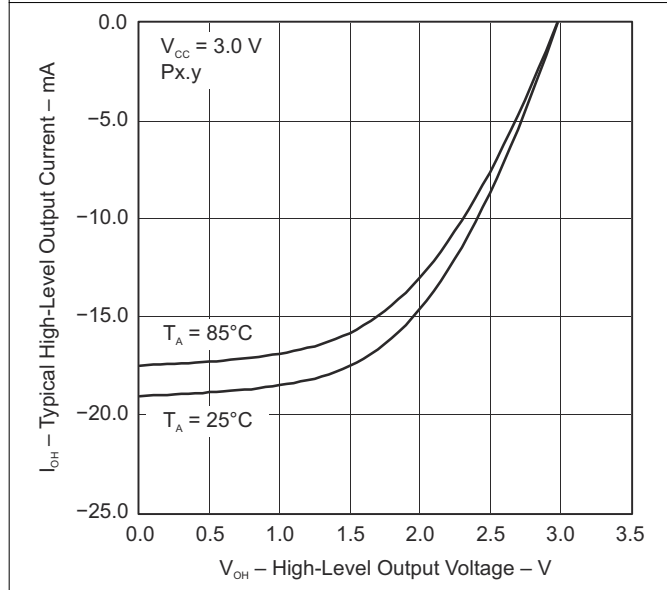

Figure 8-4. Typical High-Level Output Current vs High-Level Output Voltage

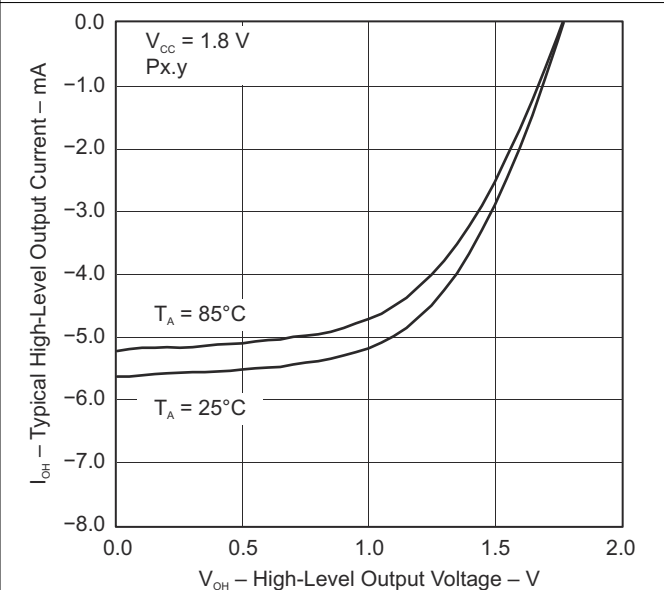

Figure 8-5. Typical High-Level Output Current vs High-Level Output Voltage

8.14 Typical Characteristics – Outputs, Full Drive Strength (PxDS.y = 1)

over recommended ranges of supply voltage and operating free-air temperature (unless otherwise noted)

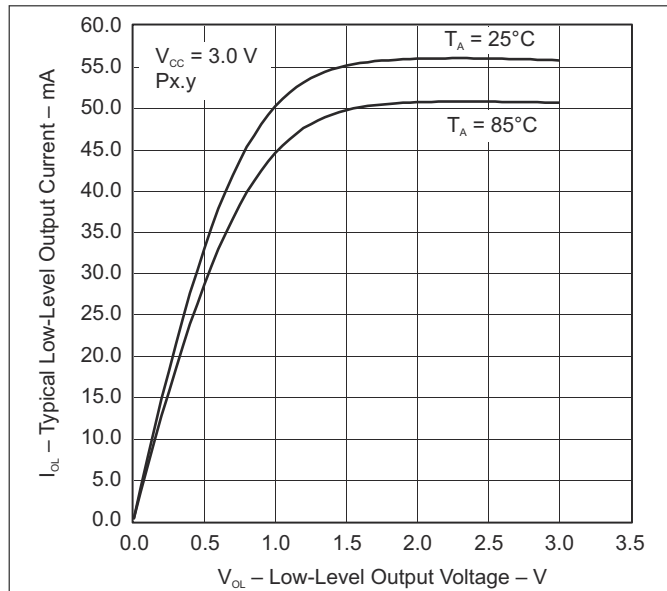

Figure 8-6. Typical Low-Level Output Current vs Low-Level Output Voltage

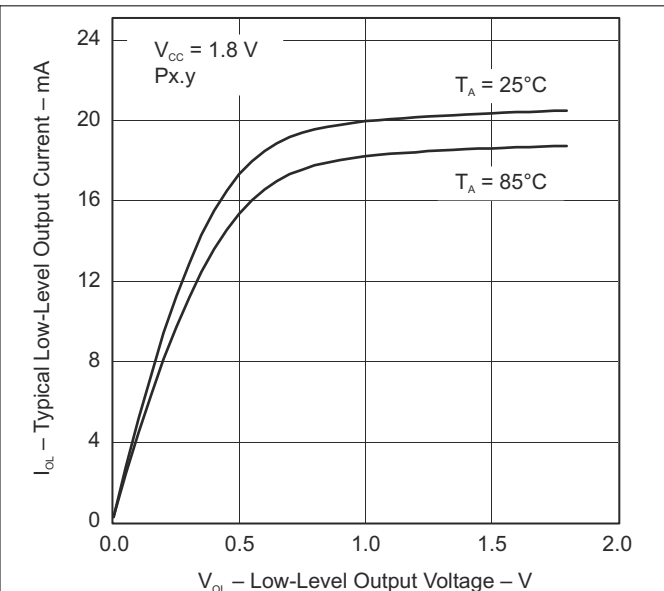

Figure 8-7. Typical Low-Level Output Current vs Low-Level Output Voltage

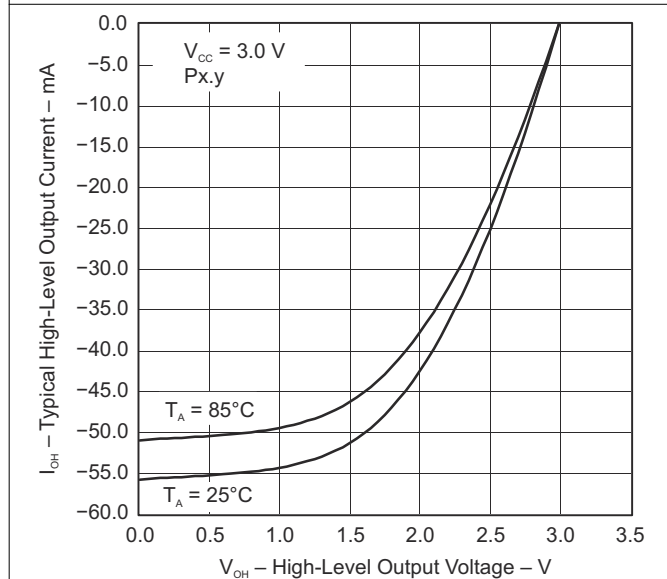

Figure 8-8. Typical High-Level Output Current vs High-Level Output Voltage

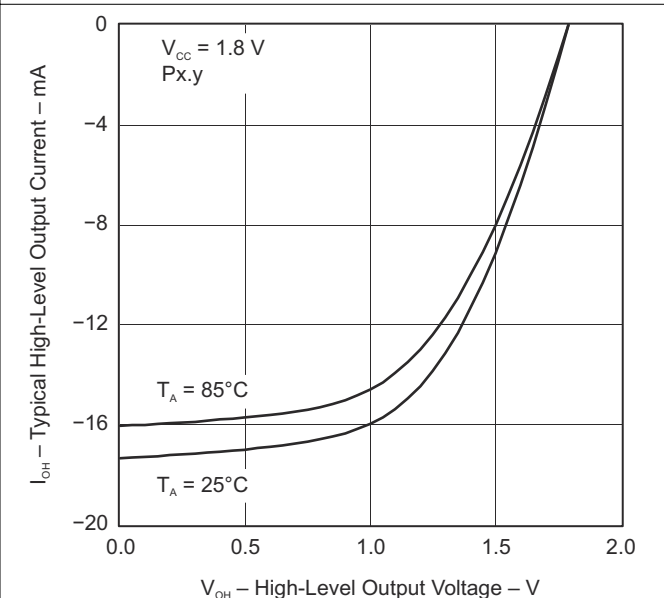

Figure 8-9. Typical High-Level Output Current vs High-Level Output Voltage

8.15 Crystal Oscillator, XT1, Low-Frequency Mode

over recommended ranges of supply voltage and operating free-air temperature (unless otherwise noted)

PARAMETER ⁽¹⁾		TEST CONDITIONS	V _{CC}	MIN	TYP	MAX	UNIT
$\Delta I_{DVCC,LF}$	Differential XT1 oscillator crystal current consumption from lowest drive setting, LF mode	$f_{OSC} = 32768 \text{ Hz}$, XTS = 0, XT1BYPASS = 0, XT1DRIVE _x = 1, T _A = 25°C	3.0 V	0.075		μA	
		$f_{OSC} = 32768 \text{ Hz}$, XTS = 0, XT1BYPASS = 0, XT1DRIVE _x = 2, T _A = 25°C		0.170			
		$f_{OSC} = 32768 \text{ Hz}$, XTS = 0, XT1BYPASS = 0, XT1DRIVE _x = 3, T _A = 25°C		0.290			
$f_{XT1,LF0}$	XT1 oscillator crystal frequency, LF mode	XTS = 0, XT1BYPASS = 0		32768		Hz	
$f_{XT1,LF,SW}$	XT1 oscillator logic-level square-wave input frequency, LF mode	XTS = 0, XT1BYPASS = 1 ^{(2) (3)}		10	32.768	50	kHz
OA_{LF}	Oscillation allowance for LF crystals ⁽⁴⁾	XTS = 0, XT1BYPASS = 0, XT1DRIVE _x = 0, $f_{XT1,LF} = 32768 \text{ Hz}$, C _{L,eff} = 6 pF		210		kΩ	
		XTS = 0, XT1BYPASS = 0, XT1DRIVE _x = 1, $f_{XT1,LF} = 32768 \text{ Hz}$, C _{L,eff} = 12 pF		300			
$C_{L,eff}$	Integrated effective load capacitance, LF mode ⁽⁵⁾	XTS = 0, XCAP _x = 0 ⁽⁶⁾		1		pF	
		XTS = 0, XCAP _x = 1		5.5			
		XTS = 0, XCAP _x = 2		8.5			
		XTS = 0, XCAP _x = 3		12.0			
	Duty cycle, LF mode	XTS = 0, Measured at ACLK, $f_{XT1,LF} = 32768 \text{ Hz}$		30%		70%	
$f_{Fault,LF}$	Oscillator fault frequency, LF mode ⁽⁷⁾	XTS = 0 ⁽⁸⁾		10		10000	Hz
$t_{START,LF}$	Start-up time, LF mode	$f_{OSC} = 32768 \text{ Hz}$, XTS = 0, XT1BYPASS = 0, XT1DRIVE _x = 0, T _A = 25°C, C _{L,eff} = 6 pF	3.0 V	1000		ms	
		$f_{OSC} = 32768 \text{ Hz}$, XTS = 0, XT1BYPASS = 0, XT1DRIVE _x = 3, T _A = 25°C, C _{L,eff} = 12 pF		500			

- (1) To improve EMI on the XT1 oscillator, the following guidelines should be observed.
 - Keep the trace between the device and the crystal as short as possible.
 - Design a good ground plane around the oscillator pins.
 - Prevent crosstalk from other clock or data lines into oscillator pins XIN and XOUT.
 - Avoid running PCB traces underneath or adjacent to the XIN and XOUT pins.
 - Use assembly materials and processes that avoid any parasitic load on the oscillator XIN and XOUT pins.
 - If conformal coating is used, ensure that it does not induce capacitive or resistive leakage between the oscillator pins.
- (2) When XT1BYPASS is set, XT1 circuits are automatically powered down. Input signal is a digital square wave with parametrics defined in the Schmitt-trigger Inputs section of this data sheet.
- (3) Maximum frequency of operation of the entire device cannot be exceeded.
- (4) Oscillation allowance is based on a safety factor of 5 for recommended crystals. The oscillation allowance is a function of the XT1DRIVE_x settings and the effective load. In general, comparable oscillator allowance can be achieved based on the following guidelines, but should be evaluated based on the actual crystal selected for the application:
 - For XT1DRIVE_x = 0, C_{L,eff} ≤ 6 pF.
 - For XT1DRIVE_x = 1, 6 pF ≤ C_{L,eff} ≤ 9 pF.
 - For XT1DRIVE_x = 2, 6 pF ≤ C_{L,eff} ≤ 10 pF.
 - For XT1DRIVE_x = 3, C_{L,eff} ≥ 6 pF.
- (5) Includes parasitic bond and package capacitance (approximately 2 pF per pin). Because the PCB adds additional capacitance, verify the correct load by measuring the ACLK frequency. For a correct setup, the effective load capacitance should always match the specification of the used crystal.
- (6) Requires external capacitors at both terminals. Values are specified by crystal manufacturers.
- (7) Frequencies below the MIN specification set the fault flag. Frequencies above the MAX specification do not set the fault flag. Frequencies between the MIN and MAX specifications might set the flag.
- (8) Measured with logic-level input frequency but also applies to operation with crystals.

8.16 Crystal Oscillator, XT2

over recommended ranges of supply voltage and operating free-air temperature (unless otherwise noted)^{(1) (2)}

PARAMETER		TEST CONDITIONS	V _{CC}	MIN	TYP	MAX	UNIT
I _{DVCC,XT2}	XT2 oscillator crystal current consumption	f _{OSC} = 4 MHz, XT2OFF = 0, XT2BYPASS = 0, XT2DRIVE _x = 0, T _A = 25°C	3.0 V		200		μA
		f _{OSC} = 12 MHz, XT2OFF = 0, XT2BYPASS = 0, XT2DRIVE _x = 1, T _A = 25°C			260		
		f _{OSC} = 20 MHz, XT2OFF = 0, XT2BYPASS = 0, XT2DRIVE _x = 2, T _A = 25°C			325		
		f _{OSC} = 32 MHz, XT2OFF = 0, XT2BYPASS = 0, XT2DRIVE _x = 3, T _A = 25°C			450		
f _{XT2,HF0}	XT2 oscillator crystal frequency, mode 0	XT2DRIVE _x = 0, XT2BYPASS = 0 ⁽³⁾		4		8	MHz
f _{XT2,HF1}	XT2 oscillator crystal frequency, mode 1	XT2DRIVE _x = 1, XT2BYPASS = 0 ⁽³⁾		8		16	MHz
f _{XT2,HF2}	XT2 oscillator crystal frequency, mode 2	XT2DRIVE _x = 2, XT2BYPASS = 0 ⁽³⁾		16		24	MHz
f _{XT2,HF3}	XT2 oscillator crystal frequency, mode 3	XT2DRIVE _x = 3, XT2BYPASS = 0 ⁽³⁾		24		32	MHz
f _{XT2,HF,SW}	XT2 oscillator logic-level square-wave input frequency, bypass mode	XT2BYPASS = 1 ^{(4) (3)}		0.7		32	MHz
O _{A,HF}	Oscillation allowance for HF crystals ⁽⁵⁾	XT2DRIVE _x = 0, XT2BYPASS = 0, f _{XT2,HF0} = 6 MHz, C _{L,eff} = 15 pF			450		Ω
		XT2DRIVE _x = 1, XT2BYPASS = 0, f _{XT2,HF1} = 12 MHz, C _{L,eff} = 15 pF			320		
		XT2DRIVE _x = 2, XT2BYPASS = 0, f _{XT2,HF2} = 20 MHz, C _{L,eff} = 15 pF			200		
		XT2DRIVE _x = 3, XT2BYPASS = 0, f _{XT2,HF3} = 32 MHz, C _{L,eff} = 15 pF			200		
t _{START,HF}	Start-up time	f _{OSC} = 6 MHz, XT2BYPASS = 0, XT2DRIVE _x = 0, T _A = 25°C, C _{L,eff} = 15 pF	3.0 V		0.5		ms
		f _{OSC} = 20 MHz, XT2BYPASS = 0, XT2DRIVE _x = 2, T _A = 25°C, C _{L,eff} = 15 pF			0.3		
C _{L,eff}	Integrated effective load capacitance, HF mode ^{(6) (1)}				1		pF
	Duty cycle	Measured at ACLK, f _{XT2,HF2} = 20 MHz		40%	50%	60%	
f _{Fault,HF}	Oscillator fault frequency ⁽⁷⁾	XT2BYPASS = 1 ⁽⁸⁾		30		300	kHz

- (1) Requires external capacitors at both terminals. Values are specified by crystal manufacturers. In general, an effective load capacitance of up to 18 pF can be supported.
- (2) To improve EMI on the XT2 oscillator the following guidelines should be observed.
 - Keep the traces between the device and the crystal as short as possible.
 - Design a good ground plane around the oscillator pins.
 - Prevent crosstalk from other clock or data lines into oscillator pins XT2IN and XT2OUT.
 - Avoid running PCB traces underneath or adjacent to the XT2IN and XT2OUT pins.
 - Use assembly materials and processes that avoid any parasitic load on the oscillator XT2IN and XT2OUT pins.
 - If conformal coating is used, ensure that it does not induce capacitive or resistive leakage between the oscillator pins.
- (3) This represents the maximum frequency that can be input to the device externally. Maximum frequency achievable on the device operation is based on the frequencies present on ACLK, MCLK, and SMCLK cannot be exceed for a given range of operation.
- (4) When XT2BYPASS is set, the XT2 circuit is automatically powered down. Input signal is a digital square wave with parametrics defined in the Schmitt-trigger Inputs section of this data sheet.
- (5) Oscillation allowance is based on a safety factor of 5 for recommended crystals.
- (6) Includes parasitic bond and package capacitance (approximately 2 pF per pin). Because the PCB adds additional capacitance, verify the correct load by measuring the ACLK frequency. For a correct setup, the effective load capacitance should always match the specification of the used crystal.

- (7) Frequencies below the MIN specification set the fault flag. Frequencies above the MAX specification do not set the fault flag. Frequencies between the MIN and MAX specifications might set the flag.
- (8) Measured with logic-level input frequency but also applies to operation with crystals.

8.17 Internal Very-Low-Power Low-Frequency Oscillator (VLO)

over recommended ranges of supply voltage and operating free-air temperature (unless otherwise noted)

PARAMETER		TEST CONDITIONS	V _{CC}	MIN	TYP	MAX	UNIT
f _{VLO}	VLO frequency	Measured at ACLK	1.8 V to 3.6 V	6	9.4	14	kHz
df _{VLO} /dT	VLO frequency temperature drift	Measured at ACLK ⁽¹⁾	1.8 V to 3.6 V		0.5		%/°C
df _{VLO} /dV _{CC}	VLO frequency supply voltage drift	Measured at ACLK ⁽²⁾	1.8 V to 3.6 V		4		%/V
	Duty cycle	Measured at ACLK	1.8 V to 3.6 V	40%	50%	60%	

(1) Calculated using the box method: $(\text{MAX}(-40^{\circ}\text{C to } 85^{\circ}\text{C}) - \text{MIN}(-40^{\circ}\text{C to } 85^{\circ}\text{C})) / \text{MIN}(-40^{\circ}\text{C to } 85^{\circ}\text{C}) / (85^{\circ}\text{C} - (-40^{\circ}\text{C}))$

(2) Calculated using the box method: $(\text{MAX}(1.8\text{ V to } 3.6\text{ V}) - \text{MIN}(1.8\text{ V to } 3.6\text{ V})) / \text{MIN}(1.8\text{ V to } 3.6\text{ V}) / (3.6\text{ V} - 1.8\text{ V})$

8.18 Internal Reference, Low-Frequency Oscillator (REFO)

over recommended ranges of supply voltage and operating free-air temperature (unless otherwise noted)

PARAMETER		TEST CONDITIONS	V _{CC}	MIN	TYP	MAX	UNIT
I _{REFO}	REFO oscillator current consumption	T _A = 25°C	1.8 V to 3.6 V		3		μA
f _{REFO}	REFO frequency calibrated	Measured at ACLK	1.8 V to 3.6 V		32768		Hz
	REFO absolute tolerance calibrated	Full temperature range	1.8 V to 3.6 V	-3.5%		3.5%	
		T _A = 25°C	3 V	-1.5%		1.5%	
df _{REFO} /dT	REFO frequency temperature drift	Measured at ACLK ⁽¹⁾	1.8 V to 3.6 V		0.01		%/°C
df _{REFO} /dV _{CC}	REFO frequency supply voltage drift	Measured at ACLK ⁽²⁾	1.8 V to 3.6 V		1.0		%/V
	Duty cycle	Measured at ACLK	1.8 V to 3.6 V	40%	50%	60%	
t _{START}	REFO start-up time	40%/60% duty cycle	1.8 V to 3.6 V		25		μs

(1) Calculated using the box method: $(\text{MAX}(-40^{\circ}\text{C to } 85^{\circ}\text{C}) - \text{MIN}(-40^{\circ}\text{C to } 85^{\circ}\text{C})) / \text{MIN}(-40^{\circ}\text{C to } 85^{\circ}\text{C}) / (85^{\circ}\text{C} - (-40^{\circ}\text{C}))$

(2) Calculated using the box method: $(\text{MAX}(1.8\text{ V to } 3.6\text{ V}) - \text{MIN}(1.8\text{ V to } 3.6\text{ V})) / \text{MIN}(1.8\text{ V to } 3.6\text{ V}) / (3.6\text{ V} - 1.8\text{ V})$

8.19 DCO Frequency

over recommended ranges of supply voltage and operating free-air temperature (unless otherwise noted)

PARAMETER		TEST CONDITIONS	MIN	TYP	MAX	UNIT
$f_{DCO(0,0)}$	DCO frequency (0, 0) ⁽¹⁾	DCORSELx = 0, DCOx = 0, MODx = 0	0.07		0.20	MHz
$f_{DCO(0,31)}$	DCO frequency (0, 31) ⁽¹⁾	DCORSELx = 0, DCOx = 31, MODx = 0	0.70		1.70	MHz
$f_{DCO(1,0)}$	DCO frequency (1, 0) ⁽¹⁾	DCORSELx = 1, DCOx = 0, MODx = 0	0.15		0.36	MHz
$f_{DCO(1,31)}$	DCO frequency (1, 31) ⁽¹⁾	DCORSELx = 1, DCOx = 31, MODx = 0	1.47		3.45	MHz
$f_{DCO(2,0)}$	DCO frequency (2, 0) ⁽¹⁾	DCORSELx = 2, DCOx = 0, MODx = 0	0.32		0.75	MHz
$f_{DCO(2,31)}$	DCO frequency (2, 31) ⁽¹⁾	DCORSELx = 2, DCOx = 31, MODx = 0	3.17		7.38	MHz
$f_{DCO(3,0)}$	DCO frequency (3, 0) ⁽¹⁾	DCORSELx = 3, DCOx = 0, MODx = 0	0.64		1.51	MHz
$f_{DCO(3,31)}$	DCO frequency (3, 31) ⁽¹⁾	DCORSELx = 3, DCOx = 31, MODx = 0	6.07		14.0	MHz
$f_{DCO(4,0)}$	DCO frequency (4, 0) ⁽¹⁾	DCORSELx = 4, DCOx = 0, MODx = 0	1.3		3.2	MHz
$f_{DCO(4,31)}$	DCO frequency (4, 31) ⁽¹⁾	DCORSELx = 4, DCOx = 31, MODx = 0	12.3		28.2	MHz
$f_{DCO(5,0)}$	DCO frequency (5, 0) ⁽¹⁾	DCORSELx = 5, DCOx = 0, MODx = 0	2.5		6.0	MHz
$f_{DCO(5,31)}$	DCO frequency (5, 31) ⁽¹⁾	DCORSELx = 5, DCOx = 31, MODx = 0	23.7		54.1	MHz
$f_{DCO(6,0)}$	DCO frequency (6, 0) ⁽¹⁾	DCORSELx = 6, DCOx = 0, MODx = 0	4.6		10.7	MHz
$f_{DCO(6,31)}$	DCO frequency (6, 31) ⁽¹⁾	DCORSELx = 6, DCOx = 31, MODx = 0	39.0		88.0	MHz
$f_{DCO(7,0)}$	DCO frequency (7, 0) ⁽¹⁾	DCORSELx = 7, DCOx = 0, MODx = 0	8.5		19.6	MHz
$f_{DCO(7,31)}$	DCO frequency (7, 31) ⁽¹⁾	DCORSELx = 7, DCOx = 31, MODx = 0	60		135	MHz
$S_{DCORSEL}$	Frequency step between range DCORSEL and DCORSEL + 1	$S_{RSEL} = f_{DCO(DCORSEL+1,DCO)} / f_{DCO(DCORSEL,DCO)}$	1.2		2.3	ratio
S_{DCO}	Frequency step between tap DCO and DCO + 1	$S_{DCO} = f_{DCO(DCORSEL,DCO+1)} / f_{DCO(DCORSEL,DCO)}$	1.02		1.12	ratio
	Duty cycle	Measured at SMCLK	40%	50%	60%	
df_{DCO}/dT	DCO frequency temperature drift ⁽²⁾	$f_{DCO} = 1$ MHz		0.1		%/°C
df_{DCO}/dV_{CC}	DCO frequency voltage drift ⁽³⁾	$f_{DCO} = 1$ MHz		1.9		%/V

- (1) When selecting the proper DCO frequency range (DCORSELx), the target DCO frequency, f_{DCO} , should be set to reside within the range of $f_{DCO(n,0),MAX} \leq f_{DCO} \leq f_{DCO(n,31),MIN}$, where $f_{DCO(n,0),MAX}$ represents the maximum frequency specified for the DCO frequency, range n, tap 0 (DCOx = 0) and $f_{DCO(n,31),MIN}$ represents the minimum frequency specified for the DCO frequency, range n, tap 31 (DCOx = 31). This ensures that the target DCO frequency resides within the range selected. It should also be noted that if the actual f_{DCO} frequency for the selected range causes the FLL or the application to select tap 0 or 31, the DCO fault flag is set to report that the selected range is at its minimum or maximum tap setting.
- (2) Calculated using the box method: $(MAX(-40^{\circ}C \text{ to } 85^{\circ}C) - MIN(-40^{\circ}C \text{ to } 85^{\circ}C)) / (MIN(-40^{\circ}C \text{ to } 85^{\circ}C) / (85^{\circ}C - (-40^{\circ}C)))$
- (3) Calculated using the box method: $(MAX(1.8 \text{ V to } 3.6 \text{ V}) - MIN(1.8 \text{ V to } 3.6 \text{ V})) / (MIN(1.8 \text{ V to } 3.6 \text{ V}) / (3.6 \text{ V} - 1.8 \text{ V}))$

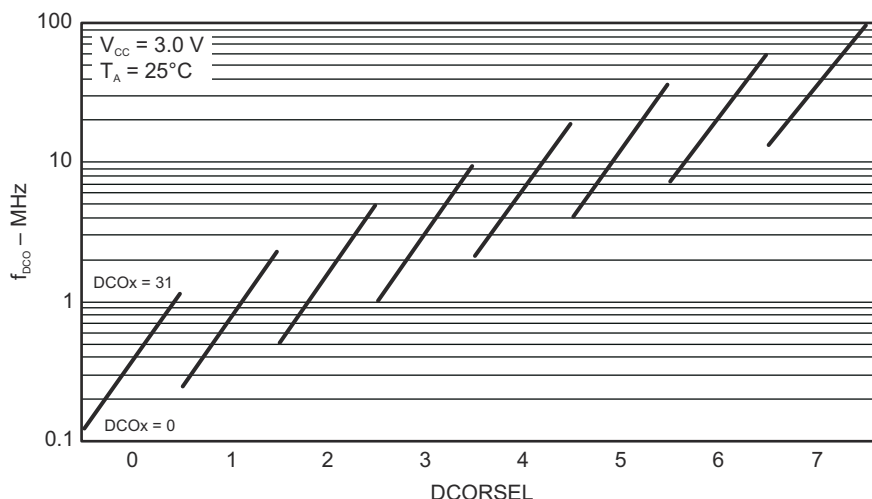

Figure 8-10. Typical DCO Frequency

8.20 PMM, Brownout Reset (BOR)

over recommended ranges of supply voltage and operating free-air temperature (unless otherwise noted)

PARAMETER		TEST CONDITIONS	MIN	TYP	MAX	UNIT
$V_{(DVCC_BOR_IT-)}$	BOR _H on voltage, DV _{CC} falling level	$ dDV_{CC}/dt < 3 \text{ V/s}$			1.45	V
$V_{(DVCC_BOR_IT+)}$	BOR _H off voltage, DV _{CC} rising level	$ dDV_{CC}/dt < 3 \text{ V/s}$	0.80	1.30	1.50	V
$V_{(DVCC_BOR_hys)}$	BOR _H hysteresis		50		250	mV
t_{RESET}	Pulse duration required at RST/NMI pin to accept a reset		2			μs

8.21 PMM, Core Voltage

over recommended ranges of supply voltage and operating free-air temperature (unless otherwise noted)

PARAMETER		TEST CONDITIONS	MIN	TYP	MAX	UNIT
$V_{\text{CORE3(AM)}}$	Core voltage, active mode, PMMCOREV = 3	$2.4 \text{ V} \leq DV_{CC} \leq 3.6 \text{ V}$		1.90		V
$V_{\text{CORE2(AM)}}$	Core voltage, active mode, PMMCOREV = 2	$2.2 \text{ V} \leq DV_{CC} \leq 3.6 \text{ V}$		1.80		V
$V_{\text{CORE1(AM)}}$	Core voltage, active mode, PMMCOREV = 1	$2.0 \text{ V} \leq DV_{CC} \leq 3.6 \text{ V}$		1.60		V
$V_{\text{CORE0(AM)}}$	Core voltage, active mode, PMMCOREV = 0	$1.8 \text{ V} \leq DV_{CC} \leq 3.6 \text{ V}$		1.40		V
$V_{\text{CORE3(LPM)}}$	Core voltage, low-current mode, PMMCOREV = 3	$2.4 \text{ V} \leq DV_{CC} \leq 3.6 \text{ V}$		1.94		V
$V_{\text{CORE2(LPM)}}$	Core voltage, low-current mode, PMMCOREV = 2	$2.2 \text{ V} \leq DV_{CC} \leq 3.6 \text{ V}$		1.84		V
$V_{\text{CORE1(LPM)}}$	Core voltage, low-current mode, PMMCOREV = 1	$2.0 \text{ V} \leq DV_{CC} \leq 3.6 \text{ V}$		1.64		V
$V_{\text{CORE0(LPM)}}$	Core voltage, low-current mode, PMMCOREV = 0	$1.8 \text{ V} \leq DV_{CC} \leq 3.6 \text{ V}$		1.44		V

8.22 PMM, SVS High Side

over recommended ranges of supply voltage and operating free-air temperature (unless otherwise noted)

PARAMETER		TEST CONDITIONS	MIN	TYP	MAX	UNIT
$I_{(SVSH)}$	SVS current consumption	SVSHE = 0, DV _{CC} = 3.6 V		0		nA
		SVSHE = 1, DV _{CC} = 3.6 V, SVSHFP = 0		200		
		SVSHE = 1, DV _{CC} = 3.6 V, SVSHFP = 1		1.5		μA
$V_{(SVSH_IT-)}$	SVS _H on voltage level ⁽¹⁾	SVSHE = 1, SVSHRVL = 0	1.57	1.68	1.78	V
		SVSHE = 1, SVSHRVL = 1	1.79	1.88	1.98	
		SVSHE = 1, SVSHRVL = 2	1.98	2.08	2.21	
		SVSHE = 1, SVSHRVL = 3	2.10	2.18	2.31	
$V_{(SVSH_IT+)}$	SVS _H off voltage level ⁽¹⁾	SVSHE = 1, SVSMHRRRL = 0	1.62	1.74	1.85	V
		SVSHE = 1, SVSMHRRRL = 1	1.88	1.94	2.07	
		SVSHE = 1, SVSMHRRRL = 2	2.07	2.14	2.28	
		SVSHE = 1, SVSMHRRRL = 3	2.20	2.30	2.42	
		SVSHE = 1, SVSMHRRRL = 4	2.32	2.40	2.55	
		SVSHE = 1, SVSMHRRRL = 5	2.52	2.70	2.88	
		SVSHE = 1, SVSMHRRRL = 6	2.90	3.10	3.23	
		SVSHE = 1, SVSMHRRRL = 7	2.90	3.10	3.23	
$t_{\text{pd(SVSH)}}$	SVS _H propagation delay	SVSHE = 1, dV _{DVCC} /dt = 10 mV/μs, SVSHFP = 1		2.5		μs
		SVSHE = 1, dV _{DVCC} /dt = 1 mV/μs, SVSHFP = 0		20		
$t_{(SVSH)}$	SVS _H on or off delay time	SVSHE = 0 → 1, SVSHFP = 1		12.5		μs
		SVSHE = 0 → 1, SVSHFP = 0		100		
dV_{DVCC}/dt	DVCC rise time		0		1000	V/s

(1) The SVS_H settings available depend on the VCORE (PMMCOREVx) setting. See the *Power Management Module and Supply Voltage Supervisor* chapter in the *MSP430F5xx and MSP430F6xx Family User's Guide* on recommended settings and use.

8.23 PMM, SVM High Side

over recommended ranges of supply voltage and operating free-air temperature (unless otherwise noted)

PARAMETER		TEST CONDITIONS	MIN	TYP	MAX	UNIT
$I_{(SVMH)}$	SVM _H current consumption	SVMHE = 0, DV _{CC} = 3.6 V		0		nA
		SVMHE = 1, DV _{CC} = 3.6 V, SVMHFP = 0		200		
		SVMHE = 1, DV _{CC} = 3.6 V, SVMHFP = 1		1.5		μA
$V_{(SVMH)}$	SVM _H on or off voltage level ⁽¹⁾	SVMHE = 1, SVSMHRRRL = 0	1.62	1.74	1.85	V
		SVMHE = 1, SVSMHRRRL = 1	1.88	1.94	2.07	
		SVMHE = 1, SVSMHRRRL = 2	2.07	2.14	2.28	
		SVMHE = 1, SVSMHRRRL = 3	2.20	2.30	2.42	
		SVMHE = 1, SVSMHRRRL = 4	2.32	2.40	2.55	
		SVMHE = 1, SVSMHRRRL = 5	2.52	2.70	2.88	
		SVMHE = 1, SVSMHRRRL = 6	2.90	3.10	3.23	
		SVMHE = 1, SVSMHRRRL = 7	2.90	3.10	3.23	
$t_{pd(SVMH)}$	SVM _H propagation delay	SVMHE = 1, dV _{DVCC} /dt = 10 mV/μs, SVMHFP = 1		2.5		μs
		SVMHE = 1, dV _{DVCC} /dt = 1 mV/μs, SVMHFP = 0		20		
$t_{(SVMH)}$	SVM _H on or off delay time	SVMHE = 0 → 1, SVMHFP = 1		12.5		μs
		SVMHE = 0 → 1, SVMHFP = 0		100		

(1) The SVM_H settings available depend on the VCORE (PMMCOREVx) setting. See the *Power Management Module and Supply Voltage Supervisor* chapter in the *MSP430F5xx and MSP430F6xx Family User's Guide* on recommended settings and use.

8.24 PMM, SVS Low Side

over recommended ranges of supply voltage and operating free-air temperature (unless otherwise noted)

PARAMETER		TEST CONDITIONS	MIN	TYP	MAX	UNIT
$I_{(SVSL)}$	SVS _L current consumption	SVSLE = 0, PMMCOREV = 2		0		nA
		SVSLE = 1, PMMCOREV = 2, SVSLFP = 0		200		
		SVSLE = 1, PMMCOREV = 2, SVSLFP = 1		1.5		μA
$t_{pd(SVSL)}$	SVS _L propagation delay	SVSLE = 1, dV _{CORE} /dt = 10 mV/μs, SVSLFP = 1		2.5		μs
		SVSLE = 1, dV _{CORE} /dt = 1 mV/μs, SVSLFP = 0		20		
$t_{(SVSL)}$	SVS _L on or off delay time	SVSLE = 0 → 1, dV _{CORE} /dt = 10 mV/μs, SVSLFP = 1		12.5		μs
		SVSLE = 0 → 1, dV _{CORE} /dt = 1 mV/μs, SVSLFP = 0		100		

8.25 PMM, SVM Low Side

over recommended ranges of supply voltage and operating free-air temperature (unless otherwise noted)

PARAMETER		TEST CONDITIONS	MIN	TYP	MAX	UNIT
$I_{(SVML)}$	SVM _L current consumption	SVMLE = 0, PMMCOREV = 2		0		nA
		SVMLE = 1, PMMCOREV = 2, SVMLFP = 0		200		
		SVMLE = 1, PMMCOREV = 2, SVMLFP = 1		1.5		μA
$t_{pd(SVML)}$	SVM _L propagation delay	SVMLE = 1, dV _{CORE} /dt = 10 mV/μs, SVMLFP = 1		2.5		μs
		SVMLE = 1, dV _{CORE} /dt = 1 mV/μs, SVMLFP = 0		20		
$t_{(SVML)}$	SVM _L on or off delay time	SVMLE = 0 → 1, dV _{CORE} /dt = 10 mV/μs, SVMLFP = 1		12.5		μs
		SVMLE = 0 → 1, dV _{CORE} /dt = 1 mV/μs, SVMLFP = 0		100		

8.26 Wake-up Times From Low-Power Modes and Reset

over recommended ranges of supply voltage and operating free-air temperature (unless otherwise noted)

PARAMETER		TEST CONDITIONS	MIN	TYP	MAX	UNIT
$t_{\text{WAKE-UP-FAST}}$	Wake-up time from LPM2, LPM3, or LPM4 to active mode ⁽¹⁾	PMMCOREV = SVSMLRRL = n (where n = 0, 1, 2, or 3), SVSLFP = 1	$f_{\text{MCLK}} \geq 4.0 \text{ MHz}$	3.5	7.5	μs
			$1.0 \text{ MHz} < f_{\text{MCLK}} < 4.0 \text{ MHz}$	4.5	9	
$t_{\text{WAKE-UP-SLOW}}$	Wake-up time from LPM2, LPM3 or LPM4 to active mode ^{(2) (3)}	PMMCOREV = SVSMLRRL = n (where n = 0, 1, 2, or 3), SVSLFP = 0		150	165	μs
$t_{\text{WAKE-UP-LPM5}}$	Wake-up time from LPM4.5 to active mode ⁽⁴⁾			2	3	ms
$t_{\text{WAKE-UP-RESET}}$	Wake-up time from $\overline{\text{RST}}$ or BOR event to active mode ⁽⁴⁾			2	3	ms

- (1) This value represents the time from the wake-up event to the first active edge of MCLK. The wake-up time depends on the performance mode of the low-side supervisor (SVS_L) and low-side monitor (SVM_L). $t_{\text{WAKE-UP-FAST}}$ is possible with SVS_L and SVM_L in full performance mode or disabled. For specific register settings, see the *Low-Side SVS and SVM Control and Performance Mode Selection* section in the *Power Management Module and Supply Voltage Supervisor* chapter of the [MSP430F5xx and MSP430F6xx Family User's Guide](#).
- (2) This value represents the time from the wake-up event to the first active edge of MCLK. The wake-up time depends on the performance mode of the low-side supervisor (SVS_L) and low-side monitor (SVM_L). $t_{\text{WAKE-UP-SLOW}}$ is set with SVS_L and SVM_L in normal mode (low current mode). For specific register settings, see the *Low-Side SVS and SVM Control and Performance Mode Selection* section in the *Power Management Module and Supply Voltage Supervisor* chapter of the [MSP430F5xx and MSP430F6xx Family User's Guide](#).
- (3) The wake-up times from LPM0 and LPM1 to AM are not specified. They are proportional to MCLK cycle time but are not affected by the performance mode settings as for LPM2, LPM3, and LPM4.
- (4) This value represents the time from the wake-up event to the reset vector execution.

8.27 Timer_A

over recommended ranges of supply voltage and operating free-air temperature (unless otherwise noted)

PARAMETER		TEST CONDITIONS	V _{CC}	MIN	MAX	UNIT
f_{TA}	Timer_A input clock frequency	Internal: SMCLK or ACLK, External: TACLK, Duty cycle = 50% ±10%	1.8 V, 3 V		25	MHz
$t_{\text{TA,cap}}$	Timer_A capture timing	All capture inputs, minimum pulse duration required for capture	1.8 V, 3 V	20		ns

8.28 Timer_B

over recommended ranges of supply voltage and operating free-air temperature (unless otherwise noted)

PARAMETER		TEST CONDITIONS	V _{CC}	MIN	MAX	UNIT
f_{TB}	Timer_B input clock frequency	Internal: SMCLK or ACLK, External: TBCLK, Duty cycle = 50% ±10%	1.8 V, 3 V		25	MHz
$t_{\text{TB,cap}}$	Timer_B capture timing	All capture inputs, minimum pulse duration required for capture	1.8 V, 3 V	20		ns

8.29 USCI (UART Mode) Clock Frequency

over recommended ranges of supply voltage and operating free-air temperature (unless otherwise noted)

PARAMETER		CONDITIONS	MIN	MAX	UNIT
f_{USCI}	USCI input clock frequency	Internal: SMCLK or ACLK, External: UCLK, Duty cycle = 50% \pm 10%		f_{SYSTEM}	MHz
f_{BITCLK}	BITCLK clock frequency (equals baud rate in MBaud)			1	MHz

8.30 USCI (UART Mode)

over recommended ranges of supply voltage and operating free-air temperature (unless otherwise noted)

PARAMETER		V_{CC}	MIN	MAX	UNIT
t_t	UART receive deglitch time ⁽¹⁾	2.2 V	50	600	ns
		3 V	50	600	

- (1) Pulses on the UART receive input (UCxRX) shorter than the UART receive deglitch time are suppressed. To ensure that pulses are correctly recognized, their duration should exceed the maximum specification of the deglitch time.

8.31 USCI (SPI Master Mode) Clock Frequency

over recommended ranges of supply voltage and operating free-air temperature (unless otherwise noted)

PARAMETER		TEST CONDITIONS	MIN	MAX	UNIT
f _{USCI}	USCI input clock frequency	Internal: SMCLK or ACLK, Duty cycle = 50% ±10%		f _{SYSTEM}	MHz

8.32 USCI (SPI Master Mode)

over recommended ranges of supply voltage and operating free-air temperature (unless otherwise noted)⁽¹⁾
(see [Figure 8-11](#) and [Figure 8-12](#))

PARAMETER		TEST CONDITIONS	V _{CC}	MIN	MAX	UNIT
f _{USCI}	USCI input clock frequency	SMCLK or ACLK, Duty cycle = 50% ±10%			f _{SYSTEM}	MHz
t _{SU,MI}	SOMI input data setup time	PMMCOREV = 0	1.8 V	55	ns	
			3.0 V	38		
		PMMCOREV = 3	2.4 V	30		
			3.0 V	25		
t _{HD,MI}	SOMI input data hold time	PMMCOREV = 0	1.8 V	0	ns	
			3.0 V	0		
		PMMCOREV = 3	2.4 V	0		
			3.0 V	0		
t _{VALID,MO}	SIMO output data valid time ⁽²⁾	UCLK edge to SIMO valid, C _L = 20 pF, PMMCOREV = 0	1.8 V		20	ns
			3.0 V		18	
		UCLK edge to SIMO valid, C _L = 20 pF, PMMCOREV = 3	2.4 V		16	
			3.0 V		15	
t _{HD,MO}	SIMO output data hold time ⁽³⁾	C _L = 20 pF, PMMCOREV = 0	1.8 V	-10	ns	
			3.0 V	-8		
		C _L = 20 pF, PMMCOREV = 3	2.4 V	-10		
			3.0 V	-8		

- (1) $f_{UCxCLK} = 1/2t_{LO/HI}$ with $t_{LO/HI} \geq \max(t_{VALID,MO}(USCI) + t_{SU,SI}(Slave), t_{SU,MI}(USCI) + t_{VALID,SO}(Slave))$
For the slave parameters $t_{SU,SI}(Slave)$ and $t_{VALID,SO}(Slave)$, see the SPI parameters of the attached slave.
- (2) Specifies the time to drive the next valid data to the SIMO output after the output changing UCLK clock edge. See the timing diagrams in [Figure 8-11](#) and [Figure 8-12](#).
- (3) Specifies how long data on the SIMO output is valid after the output changing UCLK clock edge. Negative values indicate that the data on the SIMO output can become invalid before the output changing clock edge observed on UCLK. See the timing diagrams in [Figure 8-11](#) and [Figure 8-12](#).

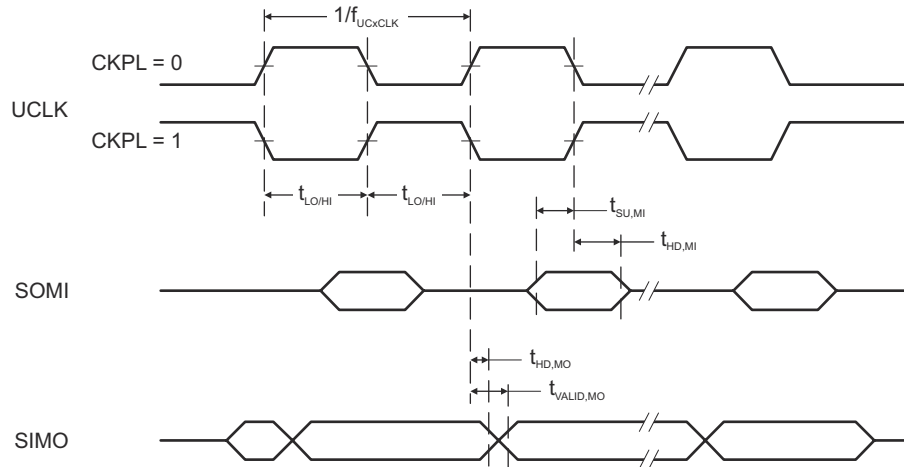

Figure 8-11. SPI Master Mode, CKPH = 0

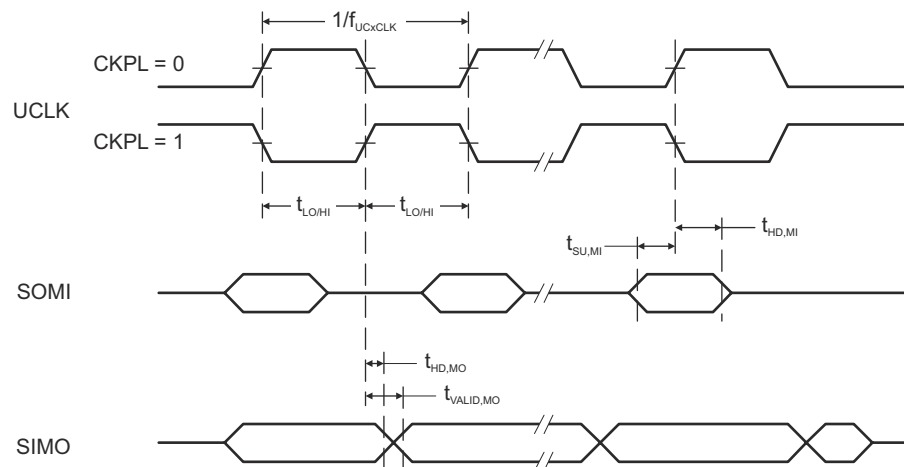

Figure 8-12. SPI Master Mode, CKPH = 1

8.33 USCI (SPI Slave Mode)

over recommended ranges of supply voltage and operating free-air temperature (unless otherwise noted)⁽¹⁾
(see [Figure 8-13](#) and [Figure 8-14](#))

PARAMETER	TEST CONDITIONS	V _{CC}	MIN	MAX	UNIT
t _{STE,LEAD} STE lead time, STE low to clock	PMMCOREV = 0	1.8 V	11		ns
		3.0 V	8		
	PMMCOREV = 3	2.4 V	7		
		3.0 V	6		
t _{STE,LAG} STE lag time, Last clock to STE high	PMMCOREV = 0	1.8 V	3		ns
		3.0 V	3		
	PMMCOREV = 3	2.4 V	3		
		3.0 V	3		
t _{STE,ACC} STE access time, STE low to SOMI data out	PMMCOREV = 0	1.8 V		66	ns
		3.0 V		50	
	PMMCOREV = 3	2.4 V		36	
		3.0 V		30	
t _{STE,DIS} STE disable time, STE high to SOMI high impedance	PMMCOREV = 0	1.8 V		30	ns
		3.0 V		23	
	PMMCOREV = 3	2.4 V		16	
		3.0 V		13	
t _{SU,SI} SIMO input data setup time	PMMCOREV = 0	1.8 V	5		ns
		3.0 V	5		
	PMMCOREV = 3	2.4 V	2		
		3.0 V	2		
t _{HD,SI} SIMO input data hold time	PMMCOREV = 0	1.8 V	5		ns
		3.0 V	5		
	PMMCOREV = 3	2.4 V	5		
		3.0 V	5		
t _{VALID,SO} SOMI output data valid time ⁽²⁾	UCLK edge to SOMI valid, C _L = 20 pF, PMMCOREV = 0	1.8 V		76	ns
		3.0 V		60	
	UCLK edge to SOMI valid, C _L = 20 pF, PMMCOREV = 3	2.4 V		44	
		3.0 V		40	
t _{HD,SO} SOMI output data hold time ⁽³⁾	C _L = 20 pF, PMMCOREV = 0	1.8 V	18		ns
		3.0 V	12		
	C _L = 20 pF, PMMCOREV = 3	2.4 V	10		
		3.0 V	8		

- (1) $f_{UCxCLK} = 1/2t_{LO/HI}$ with $t_{LO/HI} \geq \max(t_{VALID,MO(Master)} + t_{SU,SI(USCI)}, t_{SU,MI(Master)} + t_{VALID,SO(USCI)})$
For the master parameters $t_{SU,MI(Master)}$ and $t_{VALID,MO(Master)}$, see the SPI parameters of the attached master.
- (2) Specifies the time to drive the next valid data to the SOMI output after the output changing UCLK clock edge. See the timing diagrams in [Figure 8-13](#) and [Figure 8-14](#).
- (3) Specifies how long data on the SOMI output is valid after the output changing UCLK clock edge. See the timing diagrams in [Figure 8-13](#) and [Figure 8-14](#).

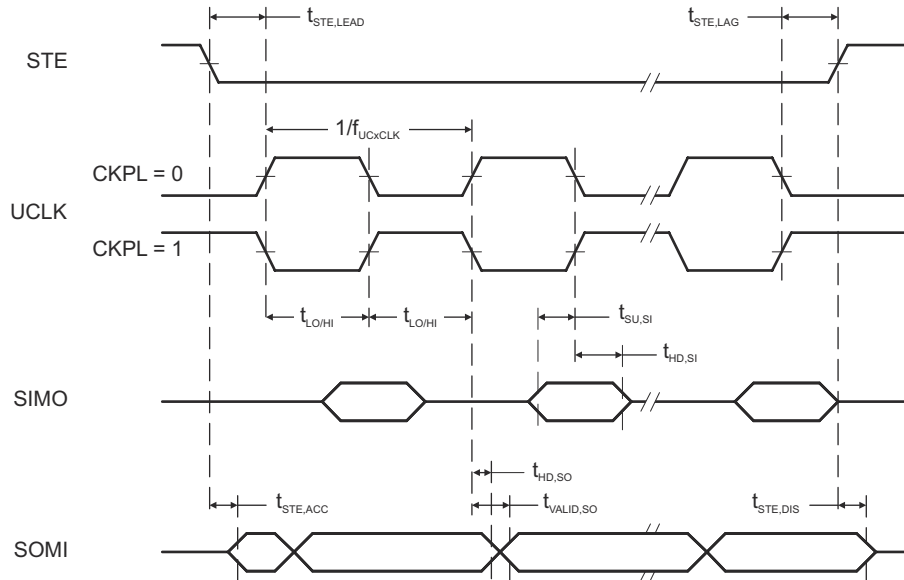

Figure 8-13. SPI Slave Mode, CKPH = 0

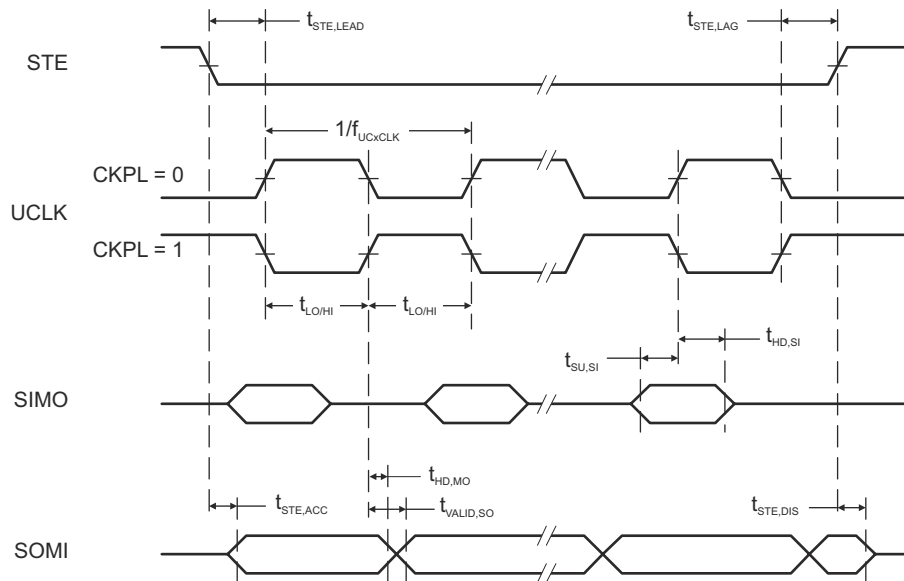

Figure 8-14. SPI Slave Mode, CKPH = 1

8.34 USCI (I²C Mode)

over recommended ranges of supply voltage and operating free-air temperature (unless otherwise noted) (see Figure 8-15)

PARAMETER	TEST CONDITIONS	V _{CC}	MIN	MAX	UNIT
f _{USCI} USCI input clock frequency	Internal: SMCLK or ACLK, External: UCLK, Duty cycle = 50% ±10%		f _{SYSTEM}		MHz
f _{SCL} SCL clock frequency		2.2 V, 3 V	0	400	kHz
t _{HD,STA} Hold time (repeated) START	f _{SCL} ≤ 100 kHz f _{SCL} > 100 kHz	2.2 V, 3 V	4.0 0.6		μs
t _{SU,STA} Setup time for a repeated START	f _{SCL} ≤ 100 kHz f _{SCL} > 100 kHz	2.2 V, 3 V	4.7 0.6		μs
t _{HD,DAT} Data hold time		2.2 V, 3 V	0		ns
t _{SU,DAT} Data setup time		2.2 V, 3 V	250		ns
t _{SU,STO} Setup time for STOP	f _{SCL} ≤ 100 kHz f _{SCL} > 100 kHz	2.2 V, 3 V	4.0 0.6		μs
t _{SP} Pulse duration of spikes suppressed by input filter		2.2 V 3 V	50 50	600 600	ns

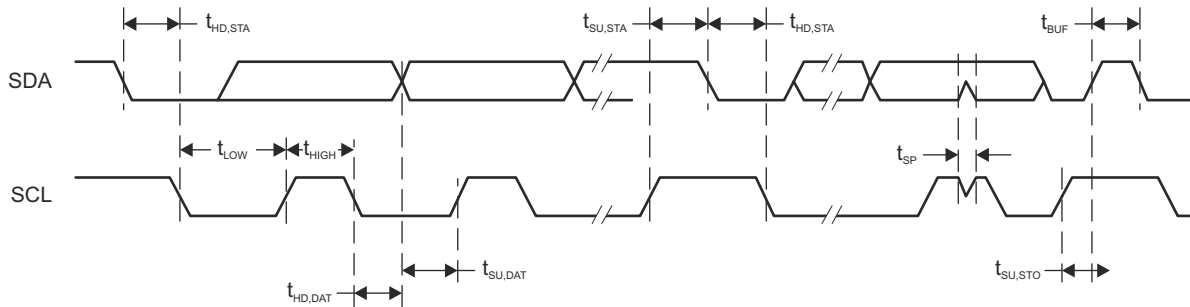

Figure 8-15. I²C Mode Timing

8.35 12-Bit ADC, Power Supply and Input Range Conditions

over recommended ranges of supply voltage and operating free-air temperature (unless otherwise noted)⁽¹⁾

PARAMETER		TEST CONDITIONS	V _{CC}	MIN	TYP	MAX	UNIT
AV _{CC}	Analog supply voltage	AV _{CC} and DV _{CC} are connected together, AV _{SS} and DV _{SS} are connected together, V _(AVSS) = V _(DVSS) = 0 V		2.2		3.6	V
V _(Ax)	Analog input voltage range ⁽²⁾	All ADC12 analog input pins Ax		0		AV _{CC}	V
I _{ADC12_A}	Operating supply current into AV _{CC} terminal ⁽³⁾	f _{ADC12CLK} = 5.0 MHz ⁽⁴⁾	2.2 V		125	155	μA
			3 V		150	220	
C _I	Input capacitance	Only one terminal Ax can be selected at one time	2.2 V		20	25	pF
R _I	Input MUX ON resistance	0 V ≤ V _{Ax} ≤ AV _{CC}		10	200	1900	Ω

- (1) The leakage current is specified by the digital I/O input leakage.
- (2) The analog input voltage range must be within the selected reference voltage range V_{R+} to V_{R-} for valid conversion results. If the reference voltage is supplied by an external source or if the internal reference voltage is used and REFOUT = 1, then decoupling capacitors are required. See Section 8.40 and Section 8.41.
- (3) The internal reference supply current is not included in current consumption parameter I_{ADC12_A}.
- (4) ADC12ON = 1, REFON = 0, SHT0 = 0, SHT1 = 0, ADC12DIV = 0

8.36 12-Bit ADC, Timing Parameters

over recommended ranges of supply voltage and operating free-air temperature (unless otherwise noted)

PARAMETER		TEST CONDITIONS	V _{CC}	MIN	TYP	MAX	UNIT
f _{ADC12CLK}	ADC conversion clock	For specified performance of ADC12 linearity parameters using an external reference voltage or AV _{CC} as reference ⁽¹⁾	2.2 V, 3 V	0.45	4.8	5.0	MHz
		For specified performance of ADC12 linearity parameters using the internal reference ⁽²⁾		0.45	2.4	4.0	
		For specified performance of ADC12 linearity parameters using the internal reference ⁽³⁾		0.45	2.4	2.7	
f _{ADC12OSC}	Internal ADC12 oscillator ⁽⁴⁾	ADC12DIV = 0, f _{ADC12CLK} = f _{ADC12OSC}	2.2 V, 3 V	4.2	4.8	5.4	MHz
t _{CONVERT}	Conversion time	REFON = 0, internal oscillator, ADC12OSC used for ADC conversion clock	2.2 V, 3 V	2.4		3.1	μs
		External f _{ADC12CLK} from ACLK, MCLK, or SMCLK, ADC12SSEL ≠ 0			13 × 1 / f _{ADC12CLK}		
t _{Sample}	Sampling time	R _S = 400 Ω, R _I = 1000 Ω, C _I = 20 pF, t = (R _S + R _I) × C _I ⁽⁵⁾	2.2 V, 3 V	1000			ns

- (1) REFOUT = 0, external reference voltage: SREF2 = 0, SREF1 = 1, SREF0 = 0. AV_{CC} as reference voltage: SREF2 = 0, SREF1 = 0, SREF0 = 0. The specified performance of the ADC12 linearity is ensured when using the ADC12OSC. For other clock sources, the specified performance of the ADC12 linearity is ensured with f_{ADC12CLK} maximum of 5.0 MHz.
- (2) SREF2 = 0, SREF1 = 1, SREF0 = 0, ADC12SR = 0, REFOUT = 1
- (3) SREF2 = 0, SREF1 = 1, SREF0 = 0, ADC12SR = 0, REFOUT = 0. The specified performance of the ADC12 linearity is ensured when using the ADC12OSC divided by 2.
- (4) The ADC12OSC is sourced directly from MODOSC inside the UCS.
- (5) Approximately 10 Tau (t) are needed to get an error of less than ±0.5 LSB:
t_{sample} = ln(2ⁿ⁺¹) × (R_S + R_I) × C_I + 800 ns, where n = ADC resolution = 12, R_S = external source resistance

8.37 12-Bit ADC, Linearity Parameters Using an External Reference Voltage or AVCC as Reference Voltage

over recommended ranges of supply voltage and operating free-air temperature (unless otherwise noted)

PARAMETER		TEST CONDITIONS	V _{CC}	MIN	TYP	MAX	UNIT
E _I	Integral linearity error ⁽¹⁾	1.4 V ≤ dVREF ≤ 1.6 V ⁽²⁾	2.2 V, 3 V			±2.0	LSB
		1.6 V < dVREF ⁽²⁾				±1.7	
E _D	Differential linearity error ⁽¹⁾	See ⁽²⁾	2.2 V, 3 V			±1.0	LSB
E _O	Offset error ⁽³⁾	dVREF ≤ 2.2 V ⁽²⁾	2.2 V, 3 V		±1.0	±2.0	LSB
		dVREF > 2.2 V ⁽²⁾			±1.0	±2.0	
E _G	Gain error ⁽³⁾	See ⁽²⁾	2.2 V, 3 V		±1.0	±2.0	LSB
E _T	Total unadjusted error	dVREF ≤ 2.2 V ⁽²⁾	2.2 V, 3 V		±1.4	±3.5	LSB
		dVREF > 2.2 V ⁽²⁾			±1.4	±3.5	

- (1) Parameters are derived using the histogram method.
- (2) The external reference voltage is selected by: SREF2 = 0 or 1, SREF1 = 1, SREF0 = 0. dVREF = V_{R+} – V_{R-}, V_{R+} < AVCC, V_{R-} > AVSS. Unless otherwise mentioned, dVREF > 1.5 V. Impedance of the external reference voltage R < 100 Ω, and two decoupling capacitors, 10 μF and 100 nF, should be connected to VREF+ and VREF- to decouple the dynamic current. Also see the [MSP430F5xx and MSP430F6xx Family User's Guide](#).
- (3) Parameters are derived using a best fit curve.

8.38 12-Bit ADC, Linearity Parameters Using the Internal Reference Voltage

over recommended ranges of supply voltage and operating free-air temperature (unless otherwise noted)

PARAMETER		TEST CONDITIONS ⁽¹⁾		V _{CC}	MIN	TYP	MAX	UNIT
E _I	Integral linearity error ⁽²⁾	ADC12SR = 0, REFOUT = 1	f _{ADC12CLK} = 4.0 MHz	2.2 V, 3 V			±1.7	LSB
		ADC12SR = 0, REFOUT = 0	f _{ADC12CLK} = 2.7 MHz				±2.5	
E _D	Differential linearity error ⁽²⁾	ADC12SR = 0, REFOUT = 1	f _{ADC12CLK} = 4.0 MHz	2.2 V, 3 V	-1.0		+2.0	LSB
		ADC12SR = 0, REFOUT = 1	f _{ADC12CLK} = 2.7 MHz		-1.0		+1.5	
		ADC12SR = 0, REFOUT = 0	f _{ADC12CLK} = 2.7 MHz		-1.0		+2.5	
E _O	Offset error ⁽³⁾	ADC12SR = 0, REFOUT = 1	f _{ADC12CLK} = 4.0 MHz	2.2 V, 3 V		±1.0	±2.0	LSB
		ADC12SR = 0, REFOUT = 0	f _{ADC12CLK} = 2.7 MHz			±1.0	±2.0	
E _G	Gain error ⁽³⁾	ADC12SR = 0, REFOUT = 1	f _{ADC12CLK} = 4.0 MHz	2.2 V, 3 V		±1.0	±2.0	LSB
		ADC12SR = 0, REFOUT = 0	f _{ADC12CLK} = 2.7 MHz				±1.5% ⁽⁴⁾	VREF
E _T	Total unadjusted error	ADC12SR = 0, REFOUT = 1	f _{ADC12CLK} = 4.0 MHz	2.2 V, 3 V		±1.4	±3.5	LSB
		ADC12SR = 0, REFOUT = 0	f _{ADC12CLK} = 2.7 MHz				±1.5% ⁽⁴⁾	VREF

- (1) The internal reference voltage is selected by: SREF2 = 0 or 1, SREF1 = 1, SREF0 = 1. dVREF = V_{R+} – V_{R-}.
- (2) Parameters are derived using the histogram method.
- (3) Parameters are derived using a best fit curve.
- (4) The gain error and total unadjusted error are dominated by the accuracy of the integrated reference module absolute accuracy. In this mode the reference voltage used by the ADC12_A is not available on a pin.

8.39 12-Bit ADC, Temperature Sensor and Built-In V_{MID}

over recommended ranges of supply voltage and operating free-air temperature (unless otherwise noted) (see Figure 8-16)

PARAMETER ⁽¹⁾		TEST CONDITIONS	V_{CC}	MIN	TYP	MAX	UNIT
V_{SENSOR}	See ⁽²⁾	ADC12ON = 1, INCH = 0Ah, $T_A = 0^\circ\text{C}$	2.2 V	680			mV
			3 V	680			
TC_{SENSOR}		ADC12ON = 1, INCH = 0Ah	2.2 V	2.25			mV/ $^\circ\text{C}$
			3 V	2.25			
$t_{SENSOR(sample)}$	Sample time required if channel 10 is selected ⁽³⁾	ADC12ON = 1, INCH = 0Ah, Error of conversion result ≤ 1 LSB	2.2 V	100			μs
			3 V	100			
V_{MID}	AV _{CC} divider at channel 11, V _{AVCC} factor	ADC12ON = 1, INCH = 0Bh		0.48	0.5	0.52	V_{AVCC}
			2.2 V	1.06	1.1	1.14	
	AV _{CC} divider at channel 11	ADC12ON = 1, INCH = 0Bh	2.2 V	1.06	1.1	1.14	V
			3 V	1.44	1.5	1.56	
$t_{VMID(sample)}$	Sample time required if channel 11 is selected ⁽⁴⁾	ADC12ON = 1, INCH = 0Bh, Error of conversion result ≤ 1 LSB	2.2 V, 3 V	1000			ns

- (1) The temperature sensor is provided by the REF module. See the REF module parametric, I_{REF+} , regarding the current consumption of the temperature sensor.
- (2) The temperature sensor offset can be significant. TI recommends a single-point calibration to minimize the offset error of the built-in temperature sensor. The TLV structure contains calibration values for $30^\circ\text{C} \pm 3^\circ\text{C}$ and $85^\circ\text{C} \pm 3^\circ\text{C}$ for each of the available reference voltage levels. The sensor voltage can be computed as $V_{SENSE} = TC_{SENSOR} \times (\text{Temperature}, ^\circ\text{C}) + V_{SENSOR}$, where TC_{SENSOR} and V_{SENSOR} can be computed from the calibration values for higher accuracy. See also the [MSP430F5xx and MSP430F6xx Family User's Guide](#).
- (3) The typical equivalent impedance of the sensor is 51 k Ω . The sample time required includes the sensor-on time $t_{SENSOR(on)}$.
- (4) The on-time $t_{VMID(on)}$ is included in the sampling time $t_{VMID(sample)}$; no additional on time is needed.

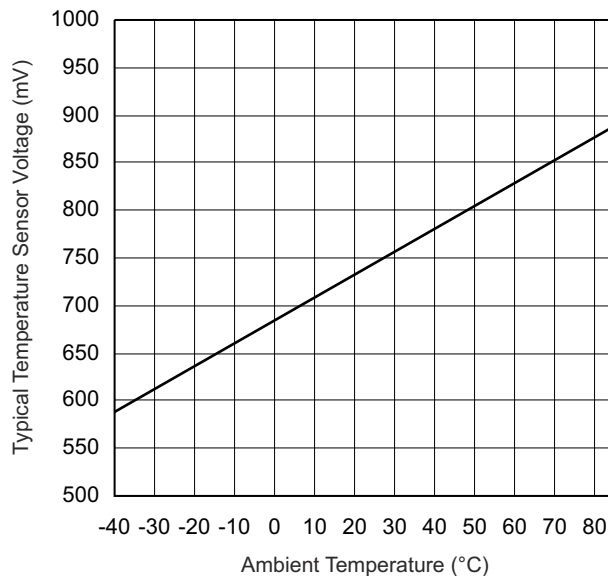

Figure 8-16. Typical Temperature Sensor Voltage

8.40 REF, External Reference

over recommended ranges of supply voltage and operating free-air temperature (unless otherwise noted)⁽¹⁾

PARAMETER		TEST CONDITIONS	V _{CC}	MIN	TYP	MAX	UNIT
V _{eREF+}	Positive external reference voltage input	V _{eREF+} > V _{REF-} and V _{eREF-} ⁽²⁾		1.4		AV _{CC}	V
V _{REF-} , V _{eREF-}	Negative external reference voltage input	V _{eREF+} > V _{REF-} and V _{eREF-} ⁽³⁾		0		1.2	V
(V _{eREF+} – V _{REF-} or V _{eREF-})	Differential external reference voltage input	V _{eREF+} > V _{REF-} and V _{eREF-} ⁽⁴⁾		1.4		AV _{CC}	V
I _{VeREF+} , I _{VREF-} , V _{eREF-}	Static input current	1.4 V ≤ V _{eREF+} ≤ V _{AVCC} , V _{eREF-} = 0 V, f _{ADC12CLK} = 5 MHz, ADC12SHTx = 1h, Conversion rate 200 ksps	2.2 V, 3 V	-26		26	μA
		1.4 V ≤ V _{eREF+} ≤ V _{AVCC} , V _{eREF-} = 0 V, f _{ADC12CLK} = 5 MHz, ADC12SHTx = 8h, Conversion rate 20 ksps		-1		1	μA
C _{VREF+} , C _{VREF-}	Capacitance at V _{VREF+} , V _{VREF-} terminal	⁽⁵⁾		10			μF

- (1) The external reference is used during ADC conversion to charge and discharge the capacitance array. The input capacitance (C_i) is also the dynamic load for an external reference during conversion. The dynamic impedance of the reference supply should follow the recommendations on analog-source impedance to allow the charge to settle for 12-bit accuracy.
- (2) The accuracy limits the minimum positive external reference voltage. Lower reference voltage levels may be applied with reduced accuracy requirements.
- (3) The accuracy limits the maximum negative external reference voltage. Higher reference voltage levels may be applied with reduced accuracy requirements.
- (4) The accuracy limits minimum external differential reference voltage. Lower differential reference voltage levels may be applied with reduced accuracy requirements.
- (5) Two decoupling capacitors, 10 μF and 100 nF, should be connected to VREF to decouple the dynamic current required for an external reference source if it is used for the ADC12_A. See also the [MSP430F5xx and MSP430F6xx Family User's Guide](#).

8.41 REF, Built-In Reference

over recommended ranges of supply voltage and operating free-air temperature (unless otherwise noted)⁽¹⁾

PARAMETER		TEST CONDITIONS	V _{CC}	MIN	TYP	MAX	UNIT
V _{REF+}	Positive built-in reference voltage output	REFVSEL = {2} for 2.5 V, REFON = REFOUT = 1, I _{VREF+} = 0 A	3 V	2.4625	2.50	2.5375	V
		REFVSEL = {1} for 2.0 V, REFON = REFOUT = 1, I _{VREF+} = 0 A		1.9503	1.98	2.0097	
		REFVSEL = {0} for 1.5 V, REFON = REFOUT = 1, I _{VREF+} = 0 A	2.2 V, 3 V	1.4677	1.49	1.5124	
AV _{CC(min)}	AV _{CC} minimum voltage, Positive built-in reference active	REFVSEL = {0} for 1.5 V		2.2			V
		REFVSEL = {1} for 2.0 V		2.3			
		REFVSEL = {2} for 2.5 V		2.8			
I _{REF+}	Operating supply current into AV _{CC} terminal ^{(2) (3)}	ADC12SR = 1 ⁽⁴⁾ , REFON = 1, REFOUT = 0, REFBURST = 0	3 V		70	100	μA
		ADC12SR = 1 ⁽⁴⁾ , REFON = 1, REFOUT = 1, REFBURST = 0			0.45	0.75	mA
		ADC12SR = 0 ⁽⁴⁾ , REFON = 1, REFOUT = 0, REFBURST = 0			210	310	μA
		ADC12SR = 0 ⁽⁴⁾ , REFON = 1, REFOUT = 1, REFBURST = 0			0.95	1.7	mA
I _{L(VREF+)}	Load-current regulation, VREF+ terminal ⁽⁵⁾	REFVSEL = (0, 1, 2), I _{VREF+} = +10 μA, -1000 μA, AV _{CC} = AV _{CC(min)} for each reference level, REFVSEL = (0, 1, 2), REFON = REFOUT = 1				2500	μV/mA

8.41 REF, Built-In Reference (continued)

over recommended ranges of supply voltage and operating free-air temperature (unless otherwise noted)⁽¹⁾

PARAMETER		TEST CONDITIONS	V _{CC}	MIN	TYP	MAX	UNIT
C _{VREF+}	Capacitance at VREF+ terminal	REFON = REFOUT = 1		20		100	pF
TC _{VREF+}	Temperature coefficient of built-in reference ⁽⁶⁾	I _{VREF+} = 0 A, REFVSEL = (0, 1, 2), REFON = 1, REFOUT = 0 or 1			30	50	ppm/ °C
PSRR _{DC}	Power supply rejection ratio (DC)	AV _{CC} = AV _{CC} (min) to AV _{CC} (max), T _A = 25°C, REFVSEL = (0, 1, 2), REFON = 1, REFOUT = 0 or 1			120	300	μV/V
PSRR _{AC}	Power supply rejection ratio (AC)	AV _{CC} = AV _{CC} (min) to AV _{CC} (max), T _A = 25°C, f = 1 kHz, ΔV _{pp} = 100 mV, REFVSEL = (0, 1, 2), REFON = 1, REFOUT = 0 or 1			6.4		mV/V
t _{SETTLE}	Settling time of reference voltage ⁽⁷⁾	AV _{CC} = AV _{CC} (min) to AV _{CC} (max), REFVSEL = (0, 1, 2), REFOUT = 0, REFON = 0 → 1			75		μs
		AV _{CC} = AV _{CC} (min) to AV _{CC} (max), C _{VREF} = C _{VREF} (max), REFVSEL = (0, 1, 2), REFOUT = 1, REFON = 0 → 1			75		

- (1) The reference is supplied to the ADC by the REF module and is buffered locally inside the ADC. The ADC uses two internal buffers, one smaller and one larger for driving the VREF+ terminal. When REFOUT = 1, the reference is available at the VREF+ terminal, as well as, used as the reference for the conversion and uses the larger buffer. When REFOUT = 0, the reference is only used as the reference for the conversion and uses the smaller buffer.
- (2) The internal reference current is supplied by the AVCC terminal. Consumption is independent of the ADC12ON control bit, unless a conversion is active. REFOUT = 0 represents the current contribution of the smaller buffer. REFOUT = 1 represents the current contribution of the larger buffer without external load.
- (3) The temperature sensor is provided by the REF module. Its current is supplied via terminal AVCC and is equivalent to I_{VREF+} with REFON = 1 and REFOUT = 0.
- (4) For devices without the ADC12, the parametrics with ADC12SR = 0 are applicable.
- (5) Contribution only due to the reference and buffer including package. This does not include resistance due to PCB trace.
- (6) Calculated using the box method: (MAX(−40°C to 85°C) – MIN(−40°C to 85°C)) / MIN(−40°C to 85°C)(85°C – (−40°C)).
- (7) The condition is that the error in a conversion started after t_{REFON} is less than ±0.5 LSB. The settling time depends on the external capacitive load when REFOUT = 1.

8.42 Comparator_B

over recommended ranges of supply voltage and operating free-air temperature (unless otherwise noted)

PARAMETER		TEST CONDITIONS	V _{CC}	MIN	TYP	MAX	UNIT
V _{CC}	Supply voltage			1.8		3.6	V
I _{AVCC_COMP}	Comparator operating supply current into AVCC, excludes reference resistor ladder	CBPWRMD = 00	1.8 V			40	μA
			2.2 V		30	50	
			3.0 V		40	65	
		CBPWRMD = 01	2.2 V, 3 V		10	30	
		CBPWRMD = 10	2.2 V, 3 V		0.1	0.5	
I _{AVCC_REF}	Quiescent current of local reference voltage amplifier into AVCC	CBREFACC = 1, CBREFLx = 01				22	μA
V _{IC}	Common mode input range			0		V _{CC} – 1	V
V _{OFFSET}	Input offset voltage	CBPWRMD = 00		–20		20	mV
		CBPWRMD = 01, 10		–10		10	
C _{IN}	Input capacitance				5		pF
R _{SIN}	Series input resistance	On (switch closed)			3	4	kΩ
		Off (switch open)		30			MΩ
t _{PD}	Propagation delay, response time	CBPWRMD = 00, CBF = 0				450	ns
		CBPWRMD = 01, CBF = 0				600	
		CBPWRMD = 10, CBF = 0				50	
t _{PD,filter}	Propagation delay with filter active	CBPWRMD = 00, CBON = 1, CBF = 1, CBFDLy = 00		0.35	0.6	1.0	μs
		CBPWRMD = 00, CBON = 1, CBF = 1, CBFDLy = 01		0.6	1.0	1.8	
		CBPWRMD = 00, CBON = 1, CBF = 1, CBFDLy = 10		1.0	1.8	3.4	
		CBPWRMD = 00, CBON = 1, CBF = 1, CBFDLy = 11		1.8	3.4	6.5	
t _{EN_CMP}	Comparator enable time, settling time	CBON = 0 to CBON = 1, CBPWRMD = 00, 01			1	2	μs
		CBON = 0 to CBON = 1, CBPWRMD = 10				100	
t _{EN_REF}	Resistor reference enable time	CBON = 0 to CBON = 1			1	1.5	μs
V _{CB_REF}	Reference voltage for a given tap	V _{IN} = reference into resistor ladder (n = 0 to 31)		$\frac{V_{IN} \times (n + 0.5)}{32}$	$\frac{V_{IN} \times (n + 1)}{32}$	$\frac{V_{IN} \times (n + 1.5)}{32}$	V

8.43 Ports PU.0 and PU.1

over recommended ranges of supply voltage and operating free-air temperature (unless otherwise noted)

PARAMETER	TEST CONDITIONS	MIN	MAX	UNIT
V _{OH}	High-level output voltage V _{USB} = 3.3 V ±10%, I _{OH} = –25 mA, see Figure 8-18 for typical characteristics	2.4		V
V _{OL}	Low-level output voltage V _{USB} = 3.3 V ±10%, I _{OL} = 25 mA, see Figure 8-17 for typical characteristics		0.4	V
V _{IH}	High-level input voltage V _{USB} = 3.3 V ±10%, see Figure 8-19 for typical characteristics	2.0		V
V _{IL}	Low-level input voltage V _{USB} = 3.3 V ±10%, see Figure 8-19 for typical characteristics		0.8	V

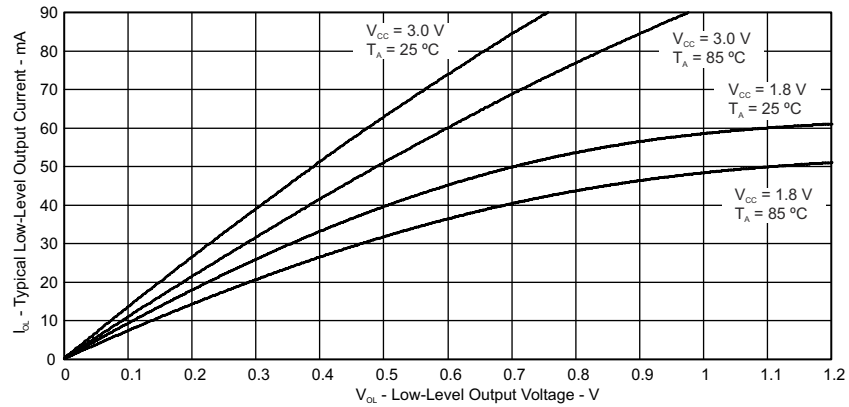

Figure 8-17. Ports PU.0, PU.1 Typical Low-Level Output Characteristics

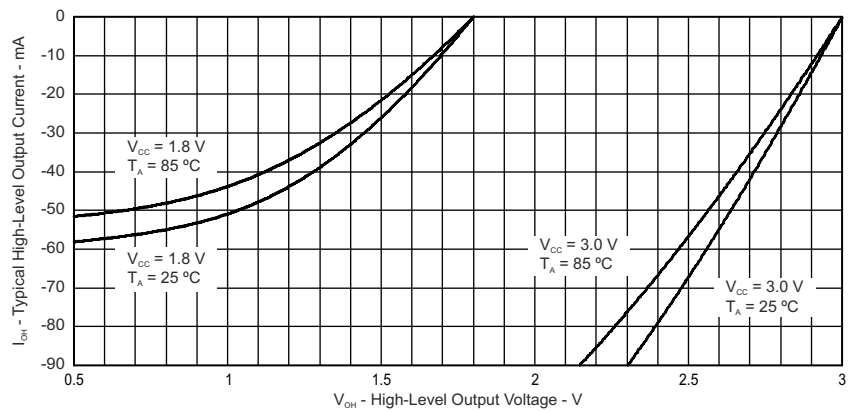

Figure 8-18. Ports PU.0, PU.1 Typical High-Level Output Characteristics

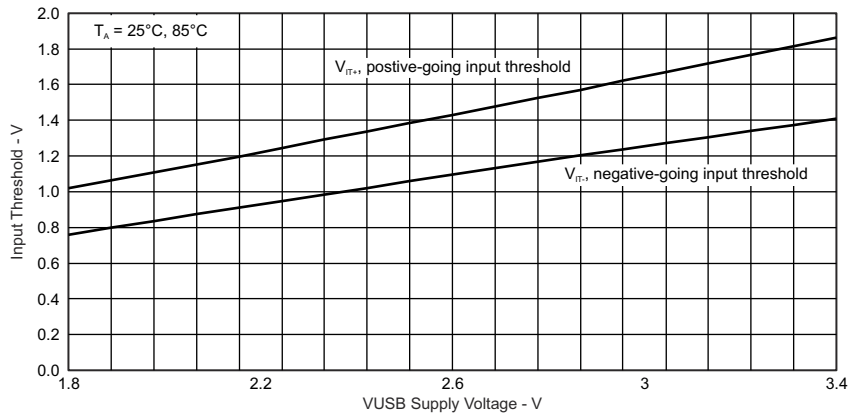

Figure 8-19. Ports PU.0, PU.1 Typical Input Threshold Characteristics

8.44 USB Output Ports DP and DM

over recommended ranges of supply voltage and operating free-air temperature (unless otherwise noted)

PARAMETER	TEST CONDITIONS	MIN	MAX	UNIT
V _{OH} D+, D– single ended	USB 2.0 load conditions	2.8	3.6	V
V _{OL} D+, D– single ended	USB 2.0 load conditions	0	0.3	V
Z _(DRV) D+, D– impedance	Including external series resistor of 27 Ω	28	44	Ω
t _{RISE} Rise time	Full speed, differential, C _L = 50 pF, 10%/90%, R _{pu} on D+	4	20	ns
t _{FALL} Fall time	Full speed, differential, C _L = 50 pF, 10%/90%, R _{pu} on D+	4	20	ns

8.45 USB Input Ports DP and DM

over recommended ranges of supply voltage and operating free-air temperature (unless otherwise noted)

PARAMETER	MIN	MAX	UNIT
V _(CM) Differential input common mode range	0.8	2.5	V
Z _(IN) Input impedance	300		kΩ
V _{CRS} Crossover voltage	1.3	2.0	V
V _{IL} Static SE input logic low level		0.8	V
V _{IH} Static SE input logic high level	2.0		V
V _{DI} Differential input voltage		0.2	V

8.46 USB-PWR (USB Power System)

over recommended ranges of supply voltage and operating free-air temperature (unless otherwise noted)

PARAMETER	TEST CONDITIONS	V _{CC}	MIN	TYP	MAX	UNIT
V _{LAUNCH} V _{BUS} detection threshold					3.75	V
V _{BUS} USB bus voltage	Normal operation		3.76		5.5	V
V _{USB} USB LDO output voltage			3.003	3.3	3.597	V
V ₁₈ Internal USB voltage ⁽¹⁾				1.8		V
I _{USB_EXT} Maximum external current from VUSB terminal ⁽²⁾	USB LDO is on				12	mA
I _{DET} USB LDO current overload detection ⁽³⁾			60		100	mA
I _{SUSPEND} Operating supply current into VBUS terminal ⁽⁴⁾	USB LDO is on, USB PLL disabled				250	μA
I _{USB_LDO} Operating supply current into VBUS terminal, represents the current of the 3.3-V LDO only	USB LDO is on, USB 1.8-V LDO is disabled, V _{BUS} = 5.0 V, USBDETEN = 0 or 1	1.8 V, 3 V		60		μA
I _{VBUS_DETECT} Operating supply current into VBUS terminal, represents the current of the VBUS detection logic	USB LDO is disabled, USB 1.8-V LDO is disabled, V _{BUS} > V _{LAUNCH} , USBDETEN = 1	1.8 V, 3 V		30		μA
C _{BUS} VBUS terminal recommended capacitance				4.7		μF
C _{USB} VUSB terminal recommended capacitance				220		nF
C ₁₈ V18 terminal recommended capacitance				220		nF
t _{ENABLE} Settling time V _{USB} and V ₁₈	Within 2%, recommended capacitances				2	ms
R _{PUR} Pullup resistance of PUR terminal ⁽⁵⁾			70	110	150	Ω

(1) This voltage is for internal uses only. No external DC loading should be applied.

(2) This represents additional current that can be supplied to the application from the VUSB terminal beyond the needs of the USB operation.

(3) A current overload is detected when the total current supplied from the USB LDO, including I_{USB_EXT}, exceeds this value.

(4) Does not include current contribution of R_{pu} and R_{pd} as outlined in the USB specification.

(5) This value, in series with an external resistor between PUR and D+, produces the Rpu as outlined in the USB specification.

8.47 USB-PLL (USB Phase-Locked Loop)

over recommended ranges of supply voltage and operating free-air temperature (unless otherwise noted)

PARAMETER		TEST CONDITIONS	MIN	TYP	MAX	UNIT
I _{PLL}	Operating supply current				7	mA
f _{PLL}	PLL frequency			48		MHz
f _{UPD}	PLL reference frequency		1.5		3	MHz
t _{LOCK}	PLL lock time				2	ms
t _{Jitter}	PLL jitter			1000		ps

8.48 Flash Memory

over recommended ranges of supply voltage and operating free-air temperature (unless otherwise noted)

PARAMETER		T _J	MIN	TYP	MAX	UNIT
DV _{CC(PGM,ERASE)}	Program and erase supply voltage		1.8		3.6	V
I _{PGM}	Average supply current from DVCC during program ⁽¹⁾			3	5	mA
I _{ERASE}	Average supply current from DVCC during erase ⁽¹⁾			6	15	mA
I _{MERASE, IBANK}	Average supply current from DVCC during mass erase or bank erase ⁽¹⁾			6	15	mA
t _{CPT}	Cumulative program time ⁽²⁾				16	ms
	Program and erase endurance		10 ⁴	10 ⁵		cycles
t _{Retention}	Data retention duration	25°C	100			years
t _{Word}	Word or byte program time ⁽³⁾		64		85	μs
t _{Block, 0}	Block program time for first byte or word ⁽³⁾		49		65	μs
t _{Block, 1–(N–1)}	Block program time for each additional byte or word, except for last byte or word ⁽³⁾		37		49	μs
t _{Block, N}	Block program time for last byte or word ⁽³⁾		55		73	μs
t _{Erase}	Erase time for segment, mass erase, and bank erase when available ⁽³⁾		23		32	ms
f _{MCLK, MGR}	MCLK frequency in marginal read mode (FCTL4.MGR0 = 1 or FCTL4.MGR1 = 1)		0		1	MHz

(1) Default clock system frequency of MCLK = 1 MHz, ACLK = 32768 Hz, SMCLK = 1 MHz. No peripherals are enabled or active.

(2) The cumulative program time must not be exceeded when writing to a 128-byte flash block. This parameter applies to all programming methods: individual word- or byte-write and block-write modes.

(3) These values are hardwired into the state machine of the flash controller.

8.49 JTAG and Spy-Bi-Wire Interface

over recommended ranges of supply voltage and operating free-air temperature (unless otherwise noted)

PARAMETER		V _{CC}	MIN	TYP	MAX	UNIT
f _{SBW}	Spy-Bi-Wire input frequency	2.2 V, 3 V	0		20	MHz
t _{SBW,Low}	Spy-Bi-Wire low clock pulse duration	2.2 V, 3 V	0.025		15	μs
t _{SBW,En}	Spy-Bi-Wire enable time (TEST high to acceptance of first clock edge) ⁽¹⁾	2.2 V, 3 V			1	μs
t _{SBW,Rst}	Spy-Bi-Wire return to normal operation time		15		100	μs
f _{TCK}	TCK input frequency, 4-wire JTAG ⁽²⁾	2.2 V	0		5	MHz
		3 V	0		10	
R _{internal}	Internal pulldown resistance on TEST	2.2 V, 3 V	45	60	80	kΩ

(1) Tools that access the Spy-Bi-Wire interface must wait for the t_{SBW,En} time after pulling the TEST/SBWTCK pin high before applying the first SBWTCK clock edge.

(2) f_{TCK} may be restricted to meet the timing requirements of the module selected.

9 Detailed Description

9.1 CPU

The MSP430 CPU has a 16-bit RISC architecture that is highly transparent to the application. All operations, other than program-flow instructions, are performed as register operations in conjunction with seven addressing modes for source operand and four addressing modes for destination operand.

The CPU is integrated with 16 registers that provide reduced instruction execution time. The register-to-register operation execution time is one cycle of the CPU clock.

Four of the registers, R0 to R3, are dedicated as program counter, stack pointer, status register, and constant generator, respectively. The remaining registers are general-purpose registers (see [Figure 9-1](#)).

Peripherals are connected to the CPU using data, address, and control buses. The peripherals can be managed with all instructions.

The instruction set consists of the original 51 instructions with three formats and seven address modes and additional instructions for the expanded address range. Each instruction can operate on word and byte data.

Program Counter	PC/R0
Stack Pointer	SP/R1
Status Register	SR/CG1/R2
Constant Generator	CG2/R3
General-Purpose Register	R4
General-Purpose Register	R5
General-Purpose Register	R6
General-Purpose Register	R7
General-Purpose Register	R8
General-Purpose Register	R9
General-Purpose Register	R10
General-Purpose Register	R11
General-Purpose Register	R12
General-Purpose Register	R13
General-Purpose Register	R14
General-Purpose Register	R15

Figure 9-1. Integrated CPU Registers

9.2 Operating Modes

These microcontrollers have one active mode and six software-selectable low-power modes of operation. An interrupt event can wake up the device from any of the low-power modes, service the request, and restore back to the low-power mode on return from the interrupt program.

Software can configure the following operating modes:

- Active mode (AM)
 - All clocks are active
- Low-power mode 0 (LPM0)
 - CPU is disabled
 - ACLK and SMCLK remain active, MCLK is disabled
 - FLL loop control remains active
- Low-power mode 1 (LPM1)
 - CPU is disabled
 - FLL loop control is disabled
 - ACLK and SMCLK remain active, MCLK is disabled
- Low-power mode 2 (LPM2)
 - CPU is disabled
 - MCLK, FLL loop control, and DCOCLK are disabled
 - DC generator of the DCO remains enabled
 - ACLK remains active
- Low-power mode 3 (LPM3)
 - CPU is disabled
 - MCLK, FLL loop control, and DCOCLK are disabled
 - DC generator of the DCO is disabled
 - ACLK remains active
- Low-power mode 4 (LPM4)
 - CPU is disabled
 - ACLK is disabled
 - MCLK, FLL loop control, and DCOCLK are disabled
 - DC generator of the DCO is disabled
 - Crystal oscillator is stopped
 - Complete data retention
- Low-power mode 4.5 (LPM4.5)
 - Internal regulator disabled
 - No data retention
 - Wake-up signal from $\overline{\text{RST}}/\text{NMI}$, P1, and P2

9.3 Interrupt Vector Addresses

The interrupt vectors and the power-up start address are in the address range 0FFFFh to 0FF80h (see [Table 9-1](#)). The vector contains the 16-bit address of the appropriate interrupt-handler instruction sequence.

Table 9-1. Interrupt Sources, Flags, and Vectors

INTERRUPT SOURCE	INTERRUPT FLAG	SYSTEM INTERRUPT	WORD ADDRESS	PRIORITY
System Reset Power up External reset Watchdog time-out, password violation Flash memory password violation	WDTIFG, KEYV (SYSRSTIV) ^{(1) (2)}	Reset	0FFFEh	63, highest
System NMI PMM Vacant memory access JTAG mailbox	SVMLIFG, SVMHIFG, DLYLIFG, DLYHIFG, VLRLIFG, VLRHIFG, VMAIFG, JMBNIFG, JMBOUTIFG (SYSSNIV) ⁽¹⁾	(Non)maskable	0FFFCh	62
User NMI NMI Oscillator fault Flash memory access violation	NMIIFG, OFIFG, ACCVIFG, BUSIFG (SYSUNIV) ^{(1) (2)}	(Non)maskable	0FFFAh	61
Comp_B	Comparator B interrupt flags (CBIV) ^{(1) (3)}	Maskable	0FFF8h	60
TB0	TB0CCR0 CCIFG0 ⁽³⁾	Maskable	0FFF6h	59
TB0	TB0CCR1 CCIFG1 to TB0CCR6 CCIFG6, TB0IFG (TB0IV) ^{(1) (3)}	Maskable	0FFF4h	58
Watchdog Timer_A interval timer mode	WDTIFG	Maskable	0FFF2h	57
USCI_A0 receive or transmit	UCA0RXIFG, UCA0TXIFG (UCA0IV) ^{(1) (3)}	Maskable	0FFF0h	56
USCI_B0 receive or transmit	UCB0RXIFG, UCB0TXIFG (UCB0IV) ^{(1) (3)}	Maskable	0FFEEh	55
ADC12_A	ADC12IFG0 to ADC12IFG15 (ADC12IV) ^{(1) (3) (4)}	Maskable	0FFECCh	54
TA0	TA0CCR0 CCIFG0 ⁽³⁾	Maskable	0FFEAh	53
TA0	TA0CCR1 CCIFG1 to TA0CCR4 CCIFG4, TA0IFG (TA0IV) ^{(1) (3)}	Maskable	0FFE8h	52
USB_UBM	USB interrupts (USBIV) ^{(1) (3)}	Maskable	0FFE6h	51
DMA	DMA0IFG, DMA1IFG, DMA2IFG (DMAIV) ^{(1) (3)}	Maskable	0FFE4h	50
TA1	TA1CCR0 CCIFG0 ⁽³⁾	Maskable	0FFE2h	49
TA1	TA1CCR1 CCIFG1 to TA1CCR2 CCIFG2, TA1IFG (TA1IV) ^{(1) (3)}	Maskable	0FFE0h	48
I/O port P1	P1IFG.0 to P1IFG.7 (P1IV) ^{(1) (3)}	Maskable	0FFDEh	47
USCI_A1 receive or transmit	UCA1RXIFG, UCA1TXIFG (UCA1IV) ^{(1) (3)}	Maskable	0FFDCh	46
USCI_B1 receive or transmit	UCB1RXIFG, UCB1TXIFG (UCB1IV) ^{(1) (3)}	Maskable	0FFDAh	45
TA2	TA2CCR0 CCIFG0 ⁽³⁾	Maskable	0FFD8h	44
TA2	TA2CCR1 CCIFG1 to TA2CCR2 CCIFG2, TA2IFG (TA2IV) ^{(1) (3)}	Maskable	0FFD6h	43
I/O port P2	P2IFG.0 to P2IFG.7 (P2IV) ^{(1) (3)}	Maskable	0FFD4h	42
RTC_A	RTCRDYIFG, RTCTEVIFG, RTCAIFG, RT0PSIFG, RT1PSIFG (RTCIV) ^{(1) (3)}	Maskable	0FFD2h	41
Reserved	Reserved ⁽⁵⁾		0FFD0h	40
			⋮	⋮
			0FF80h	0, lowest

- (1) Multiple source flags
- (2) A reset is generated if the CPU tries to fetch instructions from within peripheral space or vacant memory space.
(Non)maskable: the individual interrupt enable bit can disable an interrupt event, but the general interrupt enable bit cannot disable it.
- (3) Interrupt flags are in the module.
- (4) Only on devices with ADC, otherwise reserved.

- (5) Reserved interrupt vectors at addresses are not used in this device and can be used for regular program code if necessary. To maintain compatibility with other devices, TI recommends reserving these locations.

9.4 Memory Organization

Table 9-2 summarizes the memory map of the devices.

Table 9-2. Memory Organization ⁽¹⁾

		MSP430F5522 MSP430F5521 MSP430F5513	MSP430F5525 MSP430F5524 MSP430F5515 MSP430F5514	MSP430F5527 MSP430F5526 MSP430F5517	MSP430F5529 MSP430F5528 MSP430F5519
Memory (flash) Main: interrupt vector	Total Size	32KB 00FFFFh to 00FF80h	64KB 00FFFFh to 00FF80h	96KB 00FFFFh to 00FF80h	128KB 00FFFFh to 00FF80h
Main: code memory	Bank D	N/A	N/A	N/A	32KB 0243FFh to 01C400h
	Bank C	N/A	N/A	32KB 01C3FFh to 014400h	32KB 01C3FFh to 014400h
	Bank B	15KB 00FFFFh to 00C400h	32KB 0143FFh to 00C400h	32KB 0143FFh to 00C400h	32KB 0143FFh to 00C400h
	Bank A	17KB 00C3FFh to 008000h	32KB 00C3FFh to 004400h	32KB 00C3FFh to 004400h	32KB 00C3FFh to 004400h
RAM	Sector 3	2KB ⁽²⁾ 0043FFh to 003C00h	N/A	N/A	2KB 0043FFh to 003C00h
	Sector 2	2KB ⁽³⁾ 003BFFh to 003400h	N/A	2KB 003BFFh to 003400h	2KB 003BFFh to 003400h
	Sector 1	2KB 0033FFh to 002C00h	2KB 0033FFh to 002C00h	2KB 0033FFh to 002C00h	2KB 0033FFh to 002C00h
	Sector 0	2KB 002BFFh to 002400h	2KB 002BFFh to 002400h	2KB 002BFFh to 002400h	2KB 002BFFh to 002400h
USB RAM ⁽⁴⁾	Sector 7	2KB 0023FFh to 001C00h	2KB 0023FFh to 001C00h	2KB 0023FFh to 001C00h	2KB 0023FFh to 001C00h
Information memory (flash)	Info A	128 bytes 0019FFh to 001980h	128 bytes 0019FFh to 001980h	128 bytes 0019FFh to 001980h	128 bytes 0019FFh to 001980h
	Info B	128 bytes 00197Fh to 001900h	128 bytes 00197Fh to 001900h	128 bytes 00197Fh to 001900h	128 bytes 00197Fh to 001900h
	Info C	128 bytes 0018FFh to 001880h	128 bytes 0018FFh to 001880h	128 bytes 0018FFh to 001880h	128 bytes 0018FFh to 001880h
	Info D	128 bytes 00187Fh to 001800h	128 bytes 00187Fh to 001800h	128 bytes 00187Fh to 001800h	128 bytes 00187Fh to 001800h
Bootloader (BSL) memory (flash)	BSL 3	512 bytes 0017FFh to 001600h	512 bytes 0017FFh to 001600h	512 bytes 0017FFh to 001600h	512 bytes 0017FFh to 001600h
	BSL 2	512 bytes 0015FFh to 001400h	512 bytes 0015FFh to 001400h	512 bytes 0015FFh to 001400h	512 bytes 0015FFh to 001400h
	BSL 1	512 bytes 0013FFh to 001200h	512 bytes 0013FFh to 001200h	512 bytes 0013FFh to 001200h	512 bytes 0013FFh to 001200h
	BSL 0	512 bytes 0011FFh to 001000h	512 bytes 0011FFh to 001000h	512 bytes 0011FFh to 001000h	512 bytes 0011FFh to 001000h
Peripherals	Size	4KB 000FFFh to 0h	4KB 000FFFh to 0h	4KB 000FFFh to 0h	4KB 000FFFh to 0h

(1) N/A = Not available

(2) MSP430F5522 only

(3) MSP430F5522 and MSP430F5521 only

(4) USB RAM can be used as general purpose RAM when not used for USB operation.

9.5 Bootloader (BSL)

The BSL enables users to program the flash memory or RAM using various serial interfaces. Access to the device memory by the BSL is protected by an user-defined password. For further details on interfacing to development tools and device programmers, see the [MSP430 Hardware Tools User's Guide](#). For complete description of the features of the BSL and its implementation, see [MSP430 Programming With the Bootloader \(BSL\) User's Guide](#).

9.5.1 USB BSL

All devices come preprogrammed with the USB BSL. [Table 9-3](#) lists the required pins for the USB BSL. In addition to these pins, the application must support external components necessary for normal USB operation; for example, the proper crystal on XT2IN and XT2OUT, proper decoupling, and so on.

Table 9-3. USB BSL Pin Requirements and Functions

DEVICE SIGNAL	BSL FUNCTION
PU.0/DP	USB data terminal DP
PU.1/DM	USB data terminal DM
PUR	USB pullup resistor terminal
VBUS	USB bus power supply
VSSU	USB ground supply

Note

The default USB BSL evaluates the logic level of the PUR pin after a BOR reset. If the PUR pin is pulled high externally, then the BSL is invoked. Therefore, unless the application is invoking the BSL, it is important to keep PUR pulled low after a BOR reset, even if BSL or USB is never used. TI recommends applying a 1-M Ω resistor to ground.

9.5.2 UART BSL

A UART BSL is also available that can be programmed by the user into the BSL memory by replacing the preprogrammed, factory supplied, USB BSL. [Table 9-4](#) lists the required pins for the UART BSL.

Table 9-4. UART BSL Pin Requirements and Functions

DEVICE SIGNAL	BSL FUNCTION
RST/NMI/SBWDIO	Entry sequence signal
TEST/SBWTCK	Entry sequence signal
P1.1	Data transmit
P1.2	Data receive
VCC	Power supply
VSS	Ground supply

9.6 JTAG Operation

9.6.1 JTAG Standard Interface

The MSP430 family supports the standard JTAG interface, which requires four signals for sending and receiving data. The JTAG signals are shared with general-purpose I/O. The TEST/SBWTCK pin is used to enable the JTAG signals. In addition to these signals, the RST/NMI/SBWDIO is required to interface with MSP430 development tools and device programmers. [Table 9-5](#) lists the required pins for the JTAG interface. For further details on interfacing to development tools and device programmers, see the [MSP430 Hardware Tools User's Guide](#). For a complete description of the features of the JTAG interface and its implementation, see [MSP430 Programming With the JTAG Interface](#).

Table 9-5. JTAG Pin Requirements and Functions

DEVICE SIGNAL	DIRECTION	FUNCTION
PJ.3/TCK	IN	JTAG clock input
PJ.2/TMS	IN	JTAG state control
PJ.1/TDI/TCLK	IN	JTAG data input, TCLK input
PJ.0/TDO	OUT	JTAG data output
TEST/SBWTCK	IN	Enable JTAG pins
RST/NMI/SBWDIO	IN	External reset
VCC		Power supply
VSS		Ground supply

9.6.2 Spy-Bi-Wire Interface

In addition to the standard JTAG interface, the MSP430 family supports the two wire Spy-Bi-Wire interface. Spy-Bi-Wire can be used to interface with MSP430 development tools and device programmers. [Table 9-6](#) lists the required pins for the Spy-Bi-Wire interface. For further details on interfacing to development tools and device programmers, see the [MSP430 Hardware Tools User's Guide](#). For a complete description of the features of the JTAG interface and its implementation, see [MSP430 Programming With the JTAG Interface](#).

Table 9-6. Spy-Bi-Wire Pin Requirements and Functions

DEVICE SIGNAL	DIRECTION	FUNCTION
TEST/SBWTCK	IN	Spy-Bi-Wire clock input
RST/NMI/SBWDIO	IN, OUT	Spy-Bi-Wire data input/output
VCC		Power supply
VSS		Ground supply

9.7 Flash Memory

The flash memory can be programmed through the JTAG port, Spy-Bi-Wire (SBW), the BSL, or in-system by the CPU. The CPU can perform single-byte, single-word, and long-word writes to the flash memory. Features of the flash memory include:

- Flash memory has n segments of main memory and four segments of information memory (A to D) of 128 bytes each. Each segment in main memory is 512 bytes in size.
- Segments 0 to n may be erased in one step, or each segment may be individually erased.
- Segments A to D can be erased individually. Segments A to D are also called *information memory*.
- Segment A can be locked separately.

9.8 RAM

The RAM is made up of n sectors. Each sector can be completely powered down to save leakage; however, all data is lost. Features of the RAM include:

- RAM has n sectors. The size of a sector can be found in [Section 9.4](#).
- Each sector 0 to n can be completely disabled; however, data retention is lost.
- Each sector 0 to n automatically enters low-power retention mode when possible.
- For devices that contain USB memory, the USB memory can be used as normal RAM if USB is not required.

9.9 Peripherals

Peripherals are connected to the CPU through data, address, and control buses. Peripherals can be controlled using all instructions. For complete module descriptions, see the [MSP430F5xx and MSP430F6xx Family User's Guide](#).

9.9.1 Digital I/O

Up to eight 8-bit I/O ports are implemented: For 80-pin packages, P1, P2, P3, P4, P5, P6, and P7 are complete, and P8 is reduced to 3-bit I/O. For 64-pin packages, P3 and P5 are reduced to 5-bit I/O and 6-bit I/O, respectively, and P7 and P8 are completely removed. Port PJ contains four individual I/O ports, common to all devices.

- All individual I/O bits are independently programmable.
- Any combination of input, output, and interrupt conditions is possible.
- Pullup or pulldown on all ports is programmable.
- Drive strength on all ports is programmable.
- All bits of ports P1 and P2 support edge-selectable interrupt and LPM4.5 wake-up input.
- Read and write access to port-control registers is supported by all instructions.
- Ports can be accessed byte-wise (P1 through P8) or word-wise in pairs (PA through PD).

9.9.2 Port Mapping Controller

The port mapping controller allows the flexible and reconfigurable mapping of digital functions to port P4 (see Table 9-7). Table 9-8 shows the default mappings.

Table 9-7. Port Mapping Mnemonics and Functions

VALUE	PxMAPy MNEMONIC	INPUT PIN FUNCTION	OUTPUT PIN FUNCTION
0	PM_NONE	None	DVSS
1	PM_CBOU0	-	Comparator_B output
	PM_TB0CLK	TB0 clock input	
2	PM_ADC12CLK	-	ADC12CLK
	PM_DMAE0	DMAE0 input	
3	PM_SVMOUT	-	SVM output
	PM_TB0OUTH	TB0 high impedance input TB0OUTH	
4	PM_TB0CCR0A	TB0 CCR0 capture input CCI0A	TB0 CCR0 compare output Out0
5	PM_TB0CCR1A	TB0 CCR1 capture input CCI1A	TB0 CCR1 compare output Out1
6	PM_TB0CCR2A	TB0 CCR2 capture input CCI2A	TB0 CCR2 compare output Out2
7	PM_TB0CCR3A	TB0 CCR3 capture input CCI3A	TB0 CCR3 compare output Out3
8	PM_TB0CCR4A	TB0 CCR4 capture input CCI4A	TB0 CCR4 compare output Out4
9	PM_TB0CCR5A	TB0 CCR5 capture input CCI5A	TB0 CCR5 compare output Out5
10	PM_TB0CCR6A	TB0 CCR6 capture input CCI6A	TB0 CCR6 compare output Out6
11	PM_UCA1RXD	USCI_A1 UART RXD (Direction controlled by USCI – input)	
	PM_UCA1SOMI	USCI_A1 SPI slave out master in (direction controlled by USCI)	
12	PM_UCA1TXD	USCI_A1 UART TXD (Direction controlled by USCI – output)	
	PM_UCA1SIMO	USCI_A1 SPI slave in master out (direction controlled by USCI)	
13	PM_UCA1CLK	USCI_A1 clock input/output (direction controlled by USCI)	
	PM_UCB1STE	USCI_B1 SPI slave transmit enable (direction controlled by USCI)	
14	PM_UCB1SOMI	USCI_B1 SPI slave out master in (direction controlled by USCI)	
	PM_UCB1SCL	USCI_B1 I ² C clock (open drain and direction controlled by USCI)	
15	PM_UCB1SIMO	USCI_B1 SPI slave in master out (direction controlled by USCI)	
	PM_UCB1SDA	USCI_B1 I ² C data (open drain and direction controlled by USCI)	
16	PM_UCB1CLK	USCI_B1 clock input/output (direction controlled by USCI)	
	PM_UCA1STE	USCI_A1 SPI slave transmit enable (direction controlled by USCI)	
17	PM_CBOU1	None	Comparator_B output
18	PM_MCLK	None	MCLK
19–30	Reserved	None	DVSS
31 (0FFh) ⁽¹⁾	PM_ANALOG	Disables the output driver and the input Schmitt-trigger to prevent parasitic cross currents when applying analog signals.	

(1) The value of the PM_ANALOG mnemonic is 0FFh. The port mapping registers are 5 bits wide, and the upper bits are ignored, which results in a read value of 31.

Table 9-8. Default Mapping

PIN	PxMAPy MNEMONIC	INPUT PIN FUNCTION	OUTPUT PIN FUNCTION
P4.0/P4MAP0	PM_UCB1STE/PM_UCA1CLK	USCI_B1 SPI slave transmit enable (direction controlled by USCI) USCI_A1 clock input/output (direction controlled by USCI)	
P4.1/P4MAP1	PM_UCB1SIMO/PM_UCB1SDA	USCI_B1 SPI slave in master out (direction controlled by USCI) USCI_B1 I ² C data (open drain and direction controlled by USCI)	
P4.2/P4MAP2	PM_UCB1SOMI/PM_UCB1SCL	USCI_B1 SPI slave out master in (direction controlled by USCI) USCI_B1 I ² C clock (open drain and direction controlled by USCI)	
P4.3/P4MAP3	PM_UCB1CLK/PM_UCA1STE	USCI_A1 SPI slave transmit enable (direction controlled by USCI) USCI_B1 clock input/output (direction controlled by USCI)	
P4.4/P4MAP4	PM_UCA1TXD/PM_UCA1SIMO	USCI_A1 UART TXD (Direction controlled by USCI – output) USCI_A1 SPI slave in master out (direction controlled by USCI)	
P4.5/P4MAP5	PM_UCA1RXD/PM_UCA1SOMI	USCI_A1 UART RXD (Direction controlled by USCI – input) USCI_A1 SPI slave out master in (direction controlled by USCI)	
P4.6/P4MAP6	PM_NONE	None	DVSS
P4.7/P4MAP7	PM_NONE	None	DVSS

9.9.3 Oscillator and System Clock

The clock system in the MSP430F552x and MSP430F551x family of devices is supported by the Unified Clock System (UCS) module that includes support for a 32-kHz watch crystal oscillator (XT1 in LF mode) (XT1 in HF mode is not supported), an internal very-low-power low-frequency oscillator (VLO), an internal trimmed low-frequency oscillator (REFO), an integrated internal digitally controlled oscillator (DCO), and a high-frequency crystal oscillator (XT2). The UCS module is designed to meet the requirements of both low system cost and low power consumption. The UCS module features digital frequency-locked loop (FLL) hardware that, in conjunction with a digital modulator, stabilizes the DCO frequency to a programmable multiple of the selected FLL reference frequency. The internal DCO provides a fast turnon clock source and stabilizes in 3.5 μ s (typical). The UCS module provides the following clock signals:

- Auxiliary clock (ACLK), sourced from a 32-kHz watch crystal (XT1), a high-frequency crystal (XT2), the internal low-frequency oscillator (VLO), the trimmed low-frequency oscillator (REFO), or the internal digitally controlled oscillator (DCO).
- Main clock (MCLK), the system clock used by the CPU. MCLK can be sourced by same sources made available to ACLK.
- Sub-Main clock (SMCLK), the subsystem clock used by the peripheral modules. SMCLK can be sourced by same sources made available to ACLK.
- ACLK/n, the buffered output of ACLK, ACLK/2, ACLK/4, ACLK/8, ACLK/16, ACLK/32.

9.9.4 Power-Management Module (PMM)

The PMM includes an integrated voltage regulator that supplies the core voltage to the device and contains programmable output levels to provide for power optimization. The PMM also includes supply voltage supervisor (SVS) and supply voltage monitoring (SVM) circuitry, as well as brownout protection. The brownout circuit is implemented to provide the proper internal reset signal to the device during power on and power off. The SVS and SVM circuitry detects if the supply voltage drops below a user-selectable level and supports both supply voltage supervision (SVS) (the device is automatically reset) and supply voltage monitoring (SVM) (the device is not automatically reset). SVS and SVM circuitry is available on the primary supply and core supply.

9.9.5 Hardware Multiplier

The multiplication operation is supported by a dedicated peripheral module. The module performs operations with 32-, 24-, 16-, and 8-bit operands. The module supports signed and unsigned multiplication as well as signed and unsigned multiply-and-accumulate operations.

9.9.6 Real-Time Clock (RTC_A)

The RTC_A module can be used as a general-purpose 32-bit counter (counter mode) or as an integrated real-time clock (RTC) (calendar mode). In counter mode, the RTC_A also includes two independent 8-bit timers that can be cascaded to form a 16-bit timer/counter. Both timers can be read and written by software. Calendar mode integrates an internal calendar that compensates for months with less than 31 days and includes leap year correction. The RTC_A also supports flexible alarm functions and offset-calibration hardware.

9.9.7 Watchdog Timer (WDT_A)

The primary function of the WDT_A module is to perform a controlled system restart after a software problem occurs. If the selected time interval expires, a system reset is generated. If the watchdog function is not needed in an application, the module can be configured as an interval timer and can generate interrupts at selected time intervals.

9.9.8 System Module (SYS)

The SYS module handles many of the system functions within the device. These include power-on reset and power-up clear handling, NMI source selection and management, reset interrupt vector generators, bootstrap loader entry mechanisms, and configuration management (device descriptors). It also includes a data exchange mechanism through JTAG called a JTAG mailbox that can be used in the application. Table 9-9 lists the SYS module interrupt vector registers.

Table 9-9. System Module Interrupt Vector Registers

INTERRUPT VECTOR REGISTER	ADDRESS	INTERRUPT EVENT	VALUE	PRIORITY
SYSRSTIV, System Reset	019Eh	No interrupt pending	00h	
		Brownout (BOR)	02h	Highest
		RST/NMI (POR)	04h	
		PMMSWBOR (BOR)	06h	
		Wakeup from LPMx.5	08h	
		Security violation (BOR)	0Ah	
		SVSL (POR)	0Ch	
		SVSH (POR)	0Eh	
		SVML_OVP (POR)	10h	
		SVMH_OVP (POR)	12h	
		PMMSWPOR (POR)	14h	
		WDT time-out (PUC)	16h	
		WDT password violation (PUC)	18h	
		KEYV flash password violation (PUC)	1Ah	
		Reserved	1Ch	
		Peripheral area fetch (PUC)	1Eh	
		PMM password violation (PUC)	20h	
Reserved	22h to 3Eh	Lowest		
SYSSNIV, System NMI	019Ch	No interrupt pending	00h	
		SVMLIFG	02h	Highest
		SVMHIFG	04h	
		SVSMLDLYIFG	06h	
		SVSMHDLYIFG	08h	
		VMAIFG	0Ah	
		JMBINIFG	0Ch	
		JMBOUTIFG	0Eh	
		SVMLVLRIFG	10h	
		SVMHVLRFIFG	12h	

Table 9-9. System Module Interrupt Vector Registers (continued)

INTERRUPT VECTOR REGISTER	ADDRESS	INTERRUPT EVENT	VALUE	PRIORITY
		Reserved	14h to 1Eh	Lowest
SYSUNIV, User NMI	019Ah	No interrupt pending	00h	
		NMIIFG	02h	Highest
		OFIFG	04h	
		ACCVIFG	06h	
		BUSIFG	08h	
		Reserved	0Ah to 1Eh	Lowest

9.9.9 DMA Controller

The DMA controller allows movement of data from one memory address to another without CPU intervention. For example, the DMA controller can be used to move data from the ADC12_A conversion memory to RAM. Using the DMA controller can increase the throughput of peripheral modules. The DMA controller reduces system power consumption by allowing the CPU to remain in sleep mode, without having to awaken to move data to or from a peripheral.

The USB timestamp generator also uses the DMA trigger assignments described in [Table 9-10](#).

Table 9-10. DMA Trigger Assignments

TRIGGER ⁽¹⁾	CHANNEL		
	0	1	2
0	DMAREQ	DMAREQ	DMAREQ
1	TA0CCR0 CCIFG	TA0CCR0 CCIFG	TA0CCR0 CCIFG
2	TA0CCR2 CCIFG	TA0CCR2 CCIFG	TA0CCR2 CCIFG
3	TA1CCR0 CCIFG	TA1CCR0 CCIFG	TA1CCR0 CCIFG
4	TA1CCR2 CCIFG	TA1CCR2 CCIFG	TA1CCR2 CCIFG
5	TA2CCR0 CCIFG	TA2CCR0 CCIFG	TA2CCR0 CCIFG
6	TA2CCR2 CCIFG	TA2CCR2 CCIFG	TA2CCR2 CCIFG
7	TB0CCR0 CCIFG	TB0CCR0 CCIFG	TB0CCR0 CCIFG
8	TB0CCR2 CCIFG	TB0CCR2 CCIFG	TB0CCR2 CCIFG
9	Reserved	Reserved	Reserved
10	Reserved	Reserved	Reserved
11	Reserved	Reserved	Reserved
12	Reserved	Reserved	Reserved
13	Reserved	Reserved	Reserved
14	Reserved	Reserved	Reserved
15	Reserved	Reserved	Reserved
16	UCA0RXIFG	UCA0RXIFG	UCA0RXIFG
17	UCA0TXIFG	UCA0TXIFG	UCA0TXIFG
18	UCB0RXIFG	UCB0RXIFG	UCB0RXIFG
19	UCB0TXIFG	UCB0TXIFG	UCB0TXIFG
20	UCA1RXIFG	UCA1RXIFG	UCA1RXIFG
21	UCA1TXIFG	UCA1TXIFG	UCA1TXIFG
22	UCB1RXIFG	UCB1RXIFG	UCB1RXIFG
23	UCB1TXIFG	UCB1TXIFG	UCB1TXIFG
24	ADC12IFGx ⁽²⁾	ADC12IFGx ⁽²⁾	ADC12IFGx ⁽²⁾
25	Reserved	Reserved	Reserved
26	Reserved	Reserved	Reserved

Table 9-10. DMA Trigger Assignments (continued)

TRIGGER ⁽¹⁾	CHANNEL		
	0	1	2
27	USB FNRXD	USB FNRXD	USB FNRXD
28	USB ready	USB ready	USB ready
29	MPY ready	MPY ready	MPY ready
30	DMA2IFG	DMA0IFG	DMA1IFG
31	DMAE0	DMAE0	DMAE0

- (1) If a reserved trigger source is selected, no Trigger1 is generated.
 (2) Only on devices with ADC. Reserved on devices without ADC.

9.9.10 Universal Serial Communication Interface (USCI)

The USCI modules are used for serial data communication. The USCI module supports synchronous communication protocols such as SPI (3- or 4-pin) and I²C, and asynchronous communication protocols such as UART, enhanced UART with automatic baud-rate detection, and IrDA. Each USCI module contains two portions, A and B.

The USCI_An module provides support for SPI (3- or 4-pin), UART, enhanced UART, or IrDA.

The USCI_Bn module provides support for SPI (3- or 4-pin) or I²C.

The MSP430F55xx series includes two complete USCI modules (n = 0, 1).

9.9.11 TA0

TA0 is a 16-bit timer and counter (Timer_A type) with five capture/compare registers. TA0 can support multiple capture/compare registers, PWM outputs, and interval timing (see [Table 9-11](#)). TA0 also has extensive interrupt capabilities. Interrupts can be generated from the counter on overflow conditions and from each of the capture/compare registers.

Table 9-11. TA0 Signal Connections

INPUT PIN NUMBER		DEVICE INPUT SIGNAL	MODULE INPUT SIGNAL	MODULE BLOCK	MODULE OUTPUT SIGNAL	DEVICE OUTPUT SIGNAL	OUTPUT PIN NUMBER	
RGC, YFF, ZXH, ZQE	PN						RGC, YFF, ZXH, ZQE	PN
18, B7, H2 - P1.0	21 - P1.0	TA0CLK	TACLK	Timer	NA	NA		
		ACLK (internal)	ACLK					
		SMCLK (internal)	SMCLK					
18, B7, H2 - P1.0	21 - P1.0	TA0CLK	TACLK					
19, B6, H3 - P1.1	22 - P1.1	TA0.0	CCI0A	CCR0	TA0	TA0.0	19, B6, H3 - P1.1	22 - P1.1
		DV _{SS}	CCI0B					
		DV _{SS}	GND					
		DV _{CC}	V _{CC}					
20, C6, J3 - P1.2	23 - P1.2	TA0.1	CCI1A	CCR1	TA1	TA0.1	20, C6, J3 - P1.2	23 - P1.2
		CBOUT (internal)	CCI1B				ADC12 (internal) ⁽¹⁾	ADC12 (internal) ⁽¹⁾
		DV _{SS}	GND				ADC12SHSx = {1}	ADC12SHSx = {1}
		DV _{CC}	V _{CC}					
21, C8, G4 - P1.3	24 - P1.3	TA0.2	CCI2A	CCR2	TA2	TA0.2	21, C8, G4 - P1.3	24 - P1.3
		ACLK (internal)	CCI2B					
		DV _{SS}	GND					
		DV _{CC}	V _{CC}					
22, C7, H4 - P1.4	25 - P1.4	TA0.3	CCI3A	CCR3	TA3	TA0.3	22, C7, H4 - P1.4	25 - P1.4
		DV _{SS}	CCI3B					
		DV _{SS}	GND					
		DV _{CC}	V _{CC}					
23, D6, J4 - P1.5	26 - P1.5	TA0.4	CCI4A	CCR4	TA4	TA0.4	23, D6, J4 - P1.5	26 - P1.5
		DV _{SS}	CCI4B					
		DV _{SS}	GND					
		DV _{CC}	V _{CC}					

(1) Only on devices with ADC.

9.9.12 TA1

TA1 is a 16-bit timer and counter (Timer_A type) with three capture/compare registers. TA1 can support multiple capture/compare registers, PWM outputs, and interval timing (see [Table 9-12](#)). TA1 also has extensive interrupt capabilities. Interrupts can be generated from the counter on overflow conditions and from each of the capture/compare registers.

Table 9-12. TA1 Signal Connections

INPUT PIN NUMBER		DEVICE INPUT SIGNAL	MODULE INPUT SIGNAL	MODULE BLOCK	MODULE OUTPUT SIGNAL	DEVICE OUTPUT SIGNAL	OUTPUT PIN NUMBER	
RGC, YFF, ZXH, ZQE	PN						RGC, YFF, ZXH, ZQE	PN
24, D7, G5 - P1.6	27 - P1.6	TA1CLK	TACLK	Timer	NA	NA		
		ACLK (internal)	ACLK					
		SMCLK (internal)	SMCLK					
24, D7, G5 - P1.6	27 - P1.6	TA1CLK	$\overline{\text{TACLK}}$					
25, D8, H5 - P1.7	28 - P1.7	TA1.0	CCI0A	CCR0	TA0	TA1.0	25, D8, H5 - P1.7	28 - P1.7
		DV _{SS}	CCI0B					
		DV _{SS}	GND					
		DV _{CC}	V _{CC}					
26, E5, J5 - P2.0	29 - P2.0	TA1.1	CCI1A	CCR1	TA1	TA1.1	26, E5, J5 - P2.0	29 - P2.0
		CBOUT (internal)	CCI1B					
		DV _{SS}	GND					
		DV _{CC}	V _{CC}					
27, E8, G6 - P2.1	30 - P2.1	TA1.2	CCI2A	CCR2	TA2	TA1.2	27, E8, G6 - P2.1	30 - P2.1
		ACLK (internal)	CCI2B					
		DV _{SS}	GND					
		DV _{CC}	V _{CC}					

9.9.13 TA2

TA2 is a 16-bit timer and counter (Timer_A type) with three capture/compare registers. TA2 can support multiple capture/compare registers, PWM outputs, and interval timing (see [Table 9-13](#)). TA2 also has extensive interrupt capabilities. Interrupts can be generated from the counter on overflow conditions and from each of the capture/compare registers.

Table 9-13. TA2 Signal Connections

INPUT PIN NUMBER		DEVICE INPUT SIGNAL	MODULE INPUT SIGNAL	MODULE BLOCK	MODULE OUTPUT SIGNAL	DEVICE OUTPUT SIGNAL	OUTPUT PIN NUMBER	
RGC, YFF, ZXH, ZQE	PN						RGC, YFF, ZXH, ZQE	PN
28, E7, J6 - P2.2	31 - P2.2	TA2CLK	TACLK	Timer	NA	NA		
		ACLK (internal)	ACLK					
		SMCLK (internal)	SMCLK					
28, E7, J6 - P2.2	31 - P2.2	TA2CLK	$\overline{\text{TACLK}}$					
29, E6, H6 - P2.3	32 - P2.3	TA2.0	CCI0A	CCR0	TA0	TA2.0	29, E6, H6 - P2.3	32 - P2.3
		DV _{SS}	CCI0B					
		DV _{SS}	GND					
		DV _{CC}	V _{CC}					
30, F8, J7 - P2.4	33 - P2.4	TA2.1	CCI1A	CCR1	TA1	TA2.1	30, F8, J7 - P2.4	33 - P2.4
		CBOUT (internal)	CCI1B					
		DV _{SS}	GND					
		DV _{CC}	V _{CC}					
31, F7, J8 - P2.5	34 - P2.5	TA2.2	CCI2A	CCR2	TA2	TA2.2	31, F7, J8 - P2.5	34 - P2.5
		ACLK (internal)	CCI2B					
		DV _{SS}	GND					
		DV _{CC}	V _{CC}					

9.9.14 TB0

TB0 is a 16-bit timer and counter (Timer_B type) with seven capture/compare registers. TB0 can support multiple capture/compare registers, PWM outputs, and interval timing (see Table 9-14). TB0 also has extensive interrupt capabilities. Interrupts can be generated from the counter on overflow conditions and from each of the capture/compare registers.

Table 9-14. TB0 Signal Connections

INPUT PIN NUMBER		DEVICE INPUT SIGNAL	MODULE INPUT SIGNAL	MODULE BLOCK	MODULE OUTPUT SIGNAL	DEVICE OUTPUT SIGNAL	OUTPUT PIN NUMBER	
RGC, YFF, ZXH, ZQE ⁽¹⁾	PN						RGC, YFF, ZXH, ZQE ⁽¹⁾	PN
	60 - P7.7	TB0CLK	TBCLK	Timer	NA	NA		
		ACLK (internal)	ACLK					
		SMCLK (internal)	SMCLK					
	60 - P7.7	TB0CLK	TBCLK					
	55 - P5.6	TB0.0	CCI0A	CCR0	TB0	TB0.0		55 - P5.6
	55 - P5.6	TB0.0	CCI0B				ADC12 (internal) ⁽²⁾	ADC12 (internal) ⁽²⁾
		DV _{SS}	GND				ADC12SHSx = {2}	ADC12SHSx = {2}
		DV _{CC}	V _{CC}					
	56 - P5.7	TB0.1	CCI1A	CCR1	TB1	TB0.1		56 - P5.7
		CBOUT (internal)	CCI1B				ADC12 (internal)	ADC12 (internal)
		DV _{SS}	GND				ADC12SHSx = {3}	ADC12SHSx = {3}
		DV _{CC}	V _{CC}					
	57 - P7.4	TB0.2	CCI2A	CCR2	TB2	TB0.2		57 - P7.4
	57 - P7.4	TB0.2	CCI2B					
		DV _{SS}	GND					
		DV _{CC}	V _{CC}					
	58 - P7.5	TB0.3	CCI3A	CCR3	TB3	TB0.3		58 - P7.5
	58 - P7.5	TB0.3	CCI3B					
		DV _{SS}	GND					
		DV _{CC}	V _{CC}					
	59 - P7.6	TB0.4	CCI4A	CCR4	TB4	TB0.4		59 - P7.6
	59 - P7.6	TB0.4	CCI4B					
		DV _{SS}	GND					
		DV _{CC}	V _{CC}					
	42 - P3.5	TB0.5	CCI5A	CCR5	TB5	TB0.5		42 - P3.5
	42 - P3.5	TB0.5	CCI5B					
		DV _{SS}	GND					
		DV _{CC}	V _{CC}					
	43 - P3.6	TB0.6	CCI6A	CCR6	TB6	TB0.6		43 - P3.6
		ACLK (internal)	CCI6B					
		DV _{SS}	GND					
		DV _{CC}	V _{CC}					

(1) Timer functions are selectable through the port mapping controller.

(2) Only on devices with ADC

9.9.15 Comparator_B

The primary function of the Comparator_B module is to support precision slope analog-to-digital conversions, battery voltage supervision, and monitoring of external analog signals.

9.9.16 ADC12_A

The ADC12_A module supports fast 12-bit analog-to-digital conversions. The module implements a 12-bit SAR core, sample select control, reference generator, and a 16 word conversion-and-control buffer. The conversion-and-control buffer allows up to 16 independent ADC samples to be converted and stored without any CPU intervention.

9.9.17 CRC16

The CRC16 module produces a signature based on a sequence of entered data values and can be used for data checking purposes. The CRC16 module signature is based on the CRC-CCITT standard.

9.9.18 Voltage Reference (REF) Module

The REF module generates all critical reference voltages that can be used by the various analog peripherals in the device.

9.9.19 Universal Serial Bus (USB)

The USB module is a fully integrated USB interface that is compliant with the USB 2.0 specification. The module supports full-speed operation of control, interrupt, and bulk transfers. The module includes an integrated LDO, PHY, and PLL. The PLL is highly flexible and supports a wide range of input clock frequencies. USB RAM, when not used for USB communication, can be used by the system.

9.9.20 Embedded Emulation Module (EEM)

The EEM supports real-time in-system debugging. The L version of the EEM has the following features:

- Eight hardware triggers or breakpoints on memory access
- Two hardware triggers or breakpoints on CPU register write access
- Up to 10 hardware triggers can be combined to form complex triggers or breakpoints
- Two cycle counters
- Sequencer
- State storage
- Clock control on module level

9.9.21 Peripheral File Map

Table 9-15 lists the base address for the registers of each module. Table 9-16 through Table 9-45 list the available registers in each module.

Table 9-15. Peripherals

MODULE NAME	BASE ADDRESS	OFFSET ADDRESS RANGE
Special Functions (see Table 9-16)	0100h	000h to 01Fh
PMM (see Table 9-17)	0120h	000h to 010h
Flash Control (see Table 9-18)	0140h	000h to 00Fh
CRC16 (see Table 9-19)	0150h	000h to 007h
RAM Control (see Table 9-20)	0158h	000h to 001h
Watchdog (see Table 9-21)	015Ch	000h to 001h
UCS (see Table 9-22)	0160h	000h to 01Fh
SYS (see Table 9-23)	0180h	000h to 01Fh
Shared Reference (see Table 9-24)	01B0h	000h to 001h
Port Mapping Control (see Table 9-25)	01C0h	000h to 002h
Port Mapping Port P4 (see Table 9-25)	01E0h	000h to 007h
Port P1 and P2 (see Table 9-26)	0200h	000h to 01Fh
Port P3 and P4 (see Table 9-27)	0220h	000h to 00Bh
Port P5 and P6 (see Table 9-28)	0240h	000h to 00Bh
Port P7 and P8 (see Table 9-29)	0260h	000h to 00Bh
Port PJ (see Table 9-30)	0320h	000h to 01Fh
TA0 (see Table 9-31)	0340h	000h to 02Eh
TA1 (see Table 9-32)	0380h	000h to 02Eh
TB0 (see Table 9-33)	03C0h	000h to 02Eh
TA2 (see Table 9-34)	0400h	000h to 02Eh
Real-Time Clock (RTC_A) (see Table 9-35)	04A0h	000h to 01Bh
32-Bit Hardware Multiplier (see Table 9-36)	04C0h	000h to 02Fh
DMA General Control (see Table 9-37)	0500h	000h to 00Fh
DMA Channel 0 (see Table 9-37)	0510h	000h to 00Ah
DMA Channel 1 (see Table 9-37)	0520h	000h to 00Ah
DMA Channel 2 (see Table 9-37)	0530h	000h to 00Ah
USCI_A0 (see Table 9-38)	05C0h	000h to 01Fh
USCI_B0 (see Table 9-39)	05E0h	000h to 01Fh
USCI_A1 (see Table 9-40)	0600h	000h to 01Fh
USCI_B1 (see Table 9-41)	0620h	000h to 01Fh
ADC12_A (see Table 9-42)	0700h	000h to 03Eh
Comparator_B (see Table 9-43)	08C0h	000h to 00Fh
USB Configuration (see Table 9-44)	0900h	000h to 014h
USB Control (see Table 9-45)	0920h	000h to 01Fh

Table 9-16. Special Function Registers (Base Address: 0100h)

REGISTER DESCRIPTION	REGISTER	OFFSET
SFR interrupt enable	SFRIE1	00h
SFR interrupt flag	SFRIFG1	02h
SFR reset pin control	SFRRPCR	04h

Table 9-17. PMM Registers (Base Address: 0120h)

REGISTER DESCRIPTION	REGISTER	OFFSET
PMM control 0	PMMCTL0	00h
PMM control 1	PMMCTL1	02h
SVS high-side control	SVSMHCTL	04h
SVS low-side control	SVSMLCTL	06h
PMM interrupt flags	PMMIFG	0Ch
PMM interrupt enable	PMMIE	0Eh
PMM power mode 5 control	PM5CTL0	10h

Table 9-18. Flash Control Registers (Base Address: 0140h)

REGISTER DESCRIPTION	REGISTER	OFFSET
Flash control 1	FCTL1	00h
Flash control 3	FCTL3	04h
Flash control 4	FCTL4	06h

Table 9-19. CRC16 Registers (Base Address: 0150h)

REGISTER DESCRIPTION	REGISTER	OFFSET
CRC data input	CRC16DI	00h
CRC data input reverse byte	CRCDIRB	02h
CRC initialization and result	CRCINIRES	04h
CRC result reverse byte	CRCRESR	06h

Table 9-20. RAM Control Registers (Base Address: 0158h)

REGISTER DESCRIPTION	REGISTER	OFFSET
RAM control 0	RCCTL0	00h

Table 9-21. Watchdog Registers (Base Address: 015Ch)

REGISTER DESCRIPTION	REGISTER	OFFSET
Watchdog timer control	WDTCTL	00h

Table 9-22. UCS Registers (Base Address: 0160h)

REGISTER DESCRIPTION	REGISTER	OFFSET
UCS control 0	UCSCTL0	00h
UCS control 1	UCSCTL1	02h
UCS control 2	UCSCTL2	04h
UCS control 3	UCSCTL3	06h
UCS control 4	UCSCTL4	08h
UCS control 5	UCSCTL5	0Ah
UCS control 6	UCSCTL6	0Ch
UCS control 7	UCSCTL7	0Eh
UCS control 8	UCSCTL8	10h

Table 9-23. SYS Registers (Base Address: 0180h)

REGISTER DESCRIPTION	REGISTER	OFFSET
System control	SYSCTL	00h
Bootloader configuration area	SYSBSLC	02h
JTAG mailbox control	SYSJMBC	06h
JTAG mailbox input 0	SYSJMBI0	08h
JTAG mailbox input 1	SYSJMBI1	0Ah
JTAG mailbox output 0	SYSJMBO0	0Ch
JTAG mailbox output 1	SYSJMBO1	0Eh
Bus error vector generator	SYSBERRIV	18h
User NMI vector generator	SYSUNIV	1Ah
System NMI vector generator	SYSSNIV	1Ch
Reset vector generator	SYSRSTIV	1Eh

Table 9-24. Shared Reference Registers (Base Address: 01B0h)

REGISTER DESCRIPTION	REGISTER	OFFSET
Shared reference control	REFCTL	00h

**Table 9-25. Port Mapping Registers
(Base Address of Port Mapping Control: 01C0h, Port P4: 01E0h)**

REGISTER DESCRIPTION	REGISTER	OFFSET
Port mapping key and ID	P4MAPKEYID	00h
Port mapping control	P4MAPCTL	02h
Port P4.0 mapping	P4MAP0	00h
Port P4.1 mapping	P4MAP1	01h
Port P4.2 mapping	P4MAP2	02h
Port P4.3 mapping	P4MAP3	03h
Port P4.4 mapping	P4MAP4	04h
Port P4.5 mapping	P4MAP5	05h
Port P4.6 mapping	P4MAP6	06h
Port P4.7 mapping	P4MAP7	07h

Table 9-26. Port P1 and P2 Registers (Base Address: 0200h)

REGISTER DESCRIPTION	REGISTER	OFFSET
Port P1 input	P1IN	00h
Port P1 output	P1OUT	02h
Port P1 direction	P1DIR	04h
Port P1 resistor enable	P1REN	06h
Port P1 drive strength	P1DS	08h
Port P1 selection	P1SEL	0Ah
Port P1 interrupt vector word	P1IV	0Eh
Port P1 interrupt edge select	P1IES	18h
Port P1 interrupt enable	P1IE	1Ah
Port P1 interrupt flag	P1IFG	1Ch
Port P2 input	P2IN	01h
Port P2 output	P2OUT	03h
Port P2 direction	P2DIR	05h
Port P2 resistor enable	P2REN	07h
Port P2 drive strength	P2DS	09h
Port P2 selection	P2SEL	0Bh
Port P2 interrupt vector word	P2IV	1Eh
Port P2 interrupt edge select	P2IES	19h
Port P2 interrupt enable	P2IE	1Bh
Port P2 interrupt flag	P2IFG	1Dh

Table 9-27. Port P3 and P4 Registers (Base Address: 0220h)

REGISTER DESCRIPTION	REGISTER	OFFSET
Port P3 input	P3IN	00h
Port P3 output	P3OUT	02h
Port P3 direction	P3DIR	04h
Port P3 resistor enable	P3REN	06h
Port P3 drive strength	P3DS	08h
Port P3 selection	P3SEL	0Ah
Port P4 input	P4IN	01h
Port P4 output	P4OUT	03h
Port P4 direction	P4DIR	05h
Port P4 resistor enable	P4REN	07h
Port P4 drive strength	P4DS	09h
Port P4 selection	P4SEL	0Bh

Table 9-28. Port P5 and P6 Registers (Base Address: 0240h)

REGISTER DESCRIPTION	REGISTER	OFFSET
Port P5 input	P5IN	00h
Port P5 output	P5OUT	02h
Port P5 direction	P5DIR	04h
Port P5 resistor enable	P5REN	06h
Port P5 drive strength	P5DS	08h
Port P5 selection	P5SEL	0Ah
Port P6 input	P6IN	01h
Port P6 output	P6OUT	03h
Port P6 direction	P6DIR	05h
Port P6 resistor enable	P6REN	07h
Port P6 drive strength	P6DS	09h
Port P6 selection	P6SEL	0Bh

Table 9-29. Port P7 and P8 Registers (Base Address: 0260h)

REGISTER DESCRIPTION	REGISTER	OFFSET
Port P7 input	P7IN	00h
Port P7 output	P7OUT	02h
Port P7 direction	P7DIR	04h
Port P7 resistor enable	P7REN	06h
Port P7 drive strength	P7DS	08h
Port P7 selection	P7SEL	0Ah
Port P8 input	P8IN	01h
Port P8 output	P8OUT	03h
Port P8 direction	P8DIR	05h
Port P8 resistor enable	P8REN	07h
Port P8 drive strength	P8DS	09h
Port P8 selection	P8SEL	0Bh

Table 9-30. Port J Registers (Base Address: 0320h)

REGISTER DESCRIPTION	REGISTER	OFFSET
Port PJ input	PJIN	00h
Port PJ output	PJOUT	02h
Port PJ direction	PJDIR	04h
Port PJ resistor enable	PJREN	06h
Port PJ drive strength	PJDS	08h

Table 9-31. TA0 Registers (Base Address: 0340h)

REGISTER DESCRIPTION	REGISTER	OFFSET
TA0 control	TA0CTL	00h
Capture/compare control 0	TA0CCTL0	02h
Capture/compare control 1	TA0CCTL1	04h
Capture/compare control 2	TA0CCTL2	06h
Capture/compare control 3	TA0CCTL3	08h
Capture/compare control 4	TA0CCTL4	0Ah
TA0 counter	TA0R	10h
Capture/compare 0	TA0CCR0	12h
Capture/compare 1	TA0CCR1	14h
Capture/compare 2	TA0CCR2	16h
Capture/compare 3	TA0CCR3	18h
Capture/compare 4	TA0CCR4	1Ah
TA0 expansion 0	TA0EX0	20h
TA0 interrupt vector	TA0IV	2Eh

Table 9-32. TA1 Registers (Base Address: 0380h)

REGISTER DESCRIPTION	REGISTER	OFFSET
TA1 control	TA1CTL	00h
Capture/compare control 0	TA1CCTL0	02h
Capture/compare control 1	TA1CCTL1	04h
Capture/compare control 2	TA1CCTL2	06h
TA1 counter	TA1R	10h
Capture/compare 0	TA1CCR0	12h
Capture/compare 1	TA1CCR1	14h
Capture/compare 2	TA1CCR2	16h
TA1 expansion 0	TA1EX0	20h
TA1 interrupt vector	TA1IV	2Eh

Table 9-33. TB0 Registers (Base Address: 03C0h)

REGISTER DESCRIPTION	REGISTER	OFFSET
TB0 control	TB0CTL	00h
Capture/compare control 0	TB0CCTL0	02h
Capture/compare control 1	TB0CCTL1	04h
Capture/compare control 2	TB0CCTL2	06h
Capture/compare control 3	TB0CCTL3	08h
Capture/compare control 4	TB0CCTL4	0Ah
Capture/compare control 5	TB0CCTL5	0Ch
Capture/compare control 6	TB0CCTL6	0Eh
TB0 counter	TB0R	10h
Capture/compare 0	TB0CCR0	12h
Capture/compare 1	TB0CCR1	14h
Capture/compare 2	TB0CCR2	16h
Capture/compare 3	TB0CCR3	18h
Capture/compare 4	TB0CCR4	1Ah
Capture/compare 5	TB0CCR5	1Ch
Capture/compare 6	TB0CCR6	1Eh
TB0 expansion 0	TB0EX0	20h
TB0 interrupt vector	TB0IV	2Eh

Table 9-34. TA2 Registers (Base Address: 0400h)

REGISTER DESCRIPTION	REGISTER	OFFSET
TA2 control	TA2CTL	00h
Capture/compare control 0	TA2CCTL0	02h
Capture/compare control 1	TA2CCTL1	04h
Capture/compare control 2	TA2CCTL2	06h
TA2 counter	TA2R	10h
Capture/compare 0	TA2CCR0	12h
Capture/compare 1	TA2CCR1	14h
Capture/compare 2	TA2CCR2	16h
TA2 expansion 0	TA2EX0	20h
TA2 interrupt vector	TA2IV	2Eh

Table 9-35. Real-Time Clock Registers (Base Address: 04A0h)

REGISTER DESCRIPTION	REGISTER	OFFSET
RTC control 0	RTCCTL0	00h
RTC control 1	RTCCTL1	01h
RTC control 2	RTCCTL2	02h
RTC control 3	RTCCTL3	03h
RTC prescaler 0 control	RTCPS0CTL	08h
RTC prescaler 1 control	RTCPS1CTL	0Ah
RTC prescaler 0	RTCPS0	0Ch
RTC prescaler 1	RTCPS1	0Dh
RTC interrupt vector word	RTCIV	0Eh
RTC seconds, RTC counter 1	RTCSEC, RTCNT1	10h
RTC minutes, RTC counter 2	RTCMIN, RTCNT2	11h
RTC hours, RTC counter 3	RTCHOUR, RTCNT3	12h
RTC day of week, RTC counter 4	RTCDOW, RTCNT4	13h
RTC days	RTCDAY	14h
RTC month	RTCMON	15h
RTC year low	RTCYEARL	16h
RTC year high	RTCYEARH	17h
RTC alarm minutes	RTCAMIN	18h
RTC alarm hours	RTCAHOUR	19h
RTC alarm day of week	RTCADOW	1Ah
RTC alarm days	RTCADAY	1Bh

Table 9-36. 32-Bit Hardware Multiplier Registers (Base Address: 04C0h)

REGISTER DESCRIPTION	REGISTER	OFFSET
16-bit operand 1 – multiply	MPY	00h
16-bit operand 1 – signed multiply	MPYS	02h
16-bit operand 1 – multiply accumulate	MAC	04h
16-bit operand 1 – signed multiply accumulate	MACS	06h
16-bit operand 2	OP2	08h
16 × 16 result low word	RESLO	0Ah
16 × 16 result high word	RESHI	0Ch
16 × 16 sum extension	SUMEXT	0Eh
32-bit operand 1 – multiply low word	MPY32L	10h
32-bit operand 1 – multiply high word	MPY32H	12h
32-bit operand 1 – signed multiply low word	MPYS32L	14h
32-bit operand 1 – signed multiply high word	MPYS32H	16h
32-bit operand 1 – multiply accumulate low word	MAC32L	18h
32-bit operand 1 – multiply accumulate high word	MAC32H	1Ah
32-bit operand 1 – signed multiply accumulate low word	MACS32L	1Ch
32-bit operand 1 – signed multiply accumulate high word	MACS32H	1Eh
32-bit operand 2 – low word	OP2L	20h
32-bit operand 2 – high word	OP2H	22h
32 × 32 result 0 – least significant word	RES0	24h
32 × 32 result 1	RES1	26h
32 × 32 result 2	RES2	28h
32 × 32 result 3 – most significant word	RES3	2Ah
MPY32 control 0	MPY32CTL0	2Ch

**Table 9-37. DMA Registers (Base Address DMA General Control: 0500h,
DMA Channel 0: 0510h, DMA Channel 1: 0520h, DMA Channel 2: 0530h)**

REGISTER DESCRIPTION	REGISTER	OFFSET
DMA channel 0 control	DMA0CTL	00h
DMA channel 0 source address low	DMA0SAL	02h
DMA channel 0 source address high	DMA0SAH	04h
DMA channel 0 destination address low	DMA0DAL	06h
DMA channel 0 destination address high	DMA0DAH	08h
DMA channel 0 transfer size	DMA0SZ	0Ah
DMA channel 1 control	DMA1CTL	00h
DMA channel 1 source address low	DMA1SAL	02h
DMA channel 1 source address high	DMA1SAH	04h
DMA channel 1 destination address low	DMA1DAL	06h
DMA channel 1 destination address high	DMA1DAH	08h
DMA channel 1 transfer size	DMA1SZ	0Ah
DMA channel 2 control	DMA2CTL	00h
DMA channel 2 source address low	DMA2SAL	02h
DMA channel 2 source address high	DMA2SAH	04h
DMA channel 2 destination address low	DMA2DAL	06h
DMA channel 2 destination address high	DMA2DAH	08h
DMA channel 2 transfer size	DMA2SZ	0Ah
DMA module control 0	DMACTL0	00h
DMA module control 1	DMACTL1	02h
DMA module control 2	DMACTL2	04h
DMA module control 3	DMACTL3	06h
DMA module control 4	DMACTL4	08h
DMA interrupt vector	DMAIV	0Eh

Table 9-38. USCI_A0 Registers (Base Address: 05C0h)

REGISTER DESCRIPTION	REGISTER	OFFSET
USCI control 1	UCA0CTL1	00h
USCI control 0	UCA0CTL0	01h
USCI baud rate 0	UCA0BR0	06h
USCI baud rate 1	UCA0BR1	07h
USCI modulation control	UCA0MCTL	08h
USCI status	UCA0STAT	0Ah
USCI receive buffer	UCA0RXBUF	0Ch
USCI transmit buffer	UCA0TXBUF	0Eh
USCI LIN control	UCA0ABCTL	10h
USCI IrDA transmit control	UCA0IRTCTL	12h
USCI IrDA receive control	UCA0IRRCTL	13h
USCI interrupt enable	UCA0IE	1Ch
USCI interrupt flags	UCA0IFG	1Dh
USCI interrupt vector word	UCA0IV	1Eh

Table 9-39. USCI_B0 Registers (Base Address: 05E0h)

REGISTER DESCRIPTION	REGISTER	OFFSET
USCI synchronous control 1	UCB0CTL1	00h
USCI synchronous control 0	UCB0CTL0	01h
USCI synchronous bit rate 0	UCB0BR0	06h
USCI synchronous bit rate 1	UCB0BR1	07h
USCI synchronous status	UCB0STAT	0Ah
USCI synchronous receive buffer	UCB0RXBUF	0Ch
USCI synchronous transmit buffer	UCB0TXBUF	0Eh
USCI I2C own address	UCB0I2COA	10h
USCI I2C slave address	UCB0I2CSA	12h
USCI interrupt enable	UCB0IE	1Ch
USCI interrupt flags	UCB0IFG	1Dh
USCI interrupt vector word	UCB0IV	1Eh

Table 9-40. USCI_A1 Registers (Base Address: 0600h)

REGISTER DESCRIPTION	REGISTER	OFFSET
USCI control 1	UCA1CTL1	00h
USCI control 0	UCA1CTL0	01h
USCI baud rate 0	UCA1BR0	06h
USCI baud rate 1	UCA1BR1	07h
USCI modulation control	UCA1MCTL	08h
USCI status	UCA1STAT	0Ah
USCI receive buffer	UCA1RXBUF	0Ch
USCI transmit buffer	UCA1TXBUF	0Eh
USCI LIN control	UCA1ABCTL	10h
USCI IrDA transmit control	UCA1IRTCTL	12h
USCI IrDA receive control	UCA1IRRCTL	13h
USCI interrupt enable	UCA1IE	1Ch
USCI interrupt flags	UCA1IFG	1Dh
USCI interrupt vector word	UCA1IV	1Eh

Table 9-41. USCI_B1 Registers (Base Address: 0620h)

REGISTER DESCRIPTION	REGISTER	OFFSET
USCI synchronous control 1	UCB1CTL1	00h
USCI synchronous control 0	UCB1CTL0	01h
USCI synchronous bit rate 0	UCB1BR0	06h
USCI synchronous bit rate 1	UCB1BR1	07h
USCI synchronous status	UCB1STAT	0Ah
USCI synchronous receive buffer	UCB1RXBUF	0Ch
USCI synchronous transmit buffer	UCB1TXBUF	0Eh
USCI I2C own address	UCB1I2COA	10h
USCI I2C slave address	UCB1I2CSA	12h
USCI interrupt enable	UCB1IE	1Ch
USCI interrupt flags	UCB1IFG	1Dh
USCI interrupt vector word	UCB1IV	1Eh

Table 9-42. ADC12_A Registers (Base Address: 0700h)

REGISTER DESCRIPTION	REGISTER	OFFSET
Control 0	ADC12CTL0	00h
Control 1	ADC12CTL1	02h
Control 2	ADC12CTL2	04h
Interrupt flag	ADC12IFG	0Ah
Interrupt enable	ADC12IE	0Ch
Interrupt vector word	ADC12IV	0Eh
ADC memory control 0	ADC12MCTL0	10h
ADC memory control 1	ADC12MCTL1	11h
ADC memory control 2	ADC12MCTL2	12h
ADC memory control 3	ADC12MCTL3	13h
ADC memory control 4	ADC12MCTL4	14h
ADC memory control 5	ADC12MCTL5	15h
ADC memory control 6	ADC12MCTL6	16h
ADC memory control 7	ADC12MCTL7	17h
ADC memory control 8	ADC12MCTL8	18h
ADC memory control 9	ADC12MCTL9	19h
ADC memory control 10	ADC12MCTL10	1Ah
ADC memory control 11	ADC12MCTL11	1Bh
ADC memory control 12	ADC12MCTL12	1Ch
ADC memory control 13	ADC12MCTL13	1Dh
ADC memory control 14	ADC12MCTL14	1Eh
ADC memory control 15	ADC12MCTL15	1Fh
Conversion memory 0	ADC12MEM0	20h
Conversion memory 1	ADC12MEM1	22h
Conversion memory 2	ADC12MEM2	24h
Conversion memory 3	ADC12MEM3	26h
Conversion memory 4	ADC12MEM4	28h
Conversion memory 5	ADC12MEM5	2Ah
Conversion memory 6	ADC12MEM6	2Ch
Conversion memory 7	ADC12MEM7	2Eh
Conversion memory 8	ADC12MEM8	30h
Conversion memory 9	ADC12MEM9	32h
Conversion memory 10	ADC12MEM10	34h
Conversion memory 11	ADC12MEM11	36h
Conversion memory 12	ADC12MEM12	38h
Conversion memory 13	ADC12MEM13	3Ah
Conversion memory 14	ADC12MEM14	3Ch
Conversion memory 15	ADC12MEM15	3Eh

Table 9-43. Comparator_B Registers (Base Address: 08C0h)

REGISTER DESCRIPTION	REGISTER	OFFSET
Comp_B control 0	CBCTL0	00h
Comp_B control 1	CBCTL1	02h
Comp_B control 2	CBCTL2	04h
Comp_B control 3	CBCTL3	06h
Comp_B interrupt	CBINT	0Ch
Comp_B interrupt vector word	CBIV	0Eh

Table 9-44. USB Configuration Registers (Base Address: 0900h)

REGISTER DESCRIPTION	REGISTER	OFFSET
USB key and ID	USBKEYID	00h
USB module configuration	USBCNF	02h
USB PHY control	USBPHYCTL	04h
USB power control	USBPWRCTL	08h
USB PLL control	USBPLLCTL	10h
USB PLL divider	USBPLLDIV	12h
USB PLL interrupts	USBPLLIR	14h

Table 9-45. USB Control Registers (Base Address: 0920h)

REGISTER DESCRIPTION	REGISTER	OFFSET
Input endpoint_0 configuration	USBIEPCNF_0	00h
Input endpoint_0 byte count	USBIEPCNT_0	01h
Output endpoint_0 configuration	USBOEPCNF_0	02h
Output endpoint_0 byte count	USBOEPCNT_0	03h
Input endpoint interrupt enables	USBIEPIE	0Eh
Output endpoint interrupt enables	USBOEPIE	0Fh
Input endpoint interrupt flags	USBIEPIFG	10h
Output endpoint interrupt flags	USBOEPIFG	11h
USB interrupt vector	USBIV	12h
USB maintenance	USBMAINT	16h
Timestamp	USBTSREG	18h
USB frame number	USBFN	1Ah
USB control	USBCTL	1Ch
USB interrupt enables	USBIE	1Dh
USB interrupt flags	USBIFG	1Eh
Function address	USBFUNADR	1Fh

9.10 Input/Output Diagrams

9.10.1 Port P1 (P1.0 to P1.7) Input/Output With Schmitt Trigger

Figure 9-2 shows the port diagram. Table 9-46 summarizes the selection of the pin function.

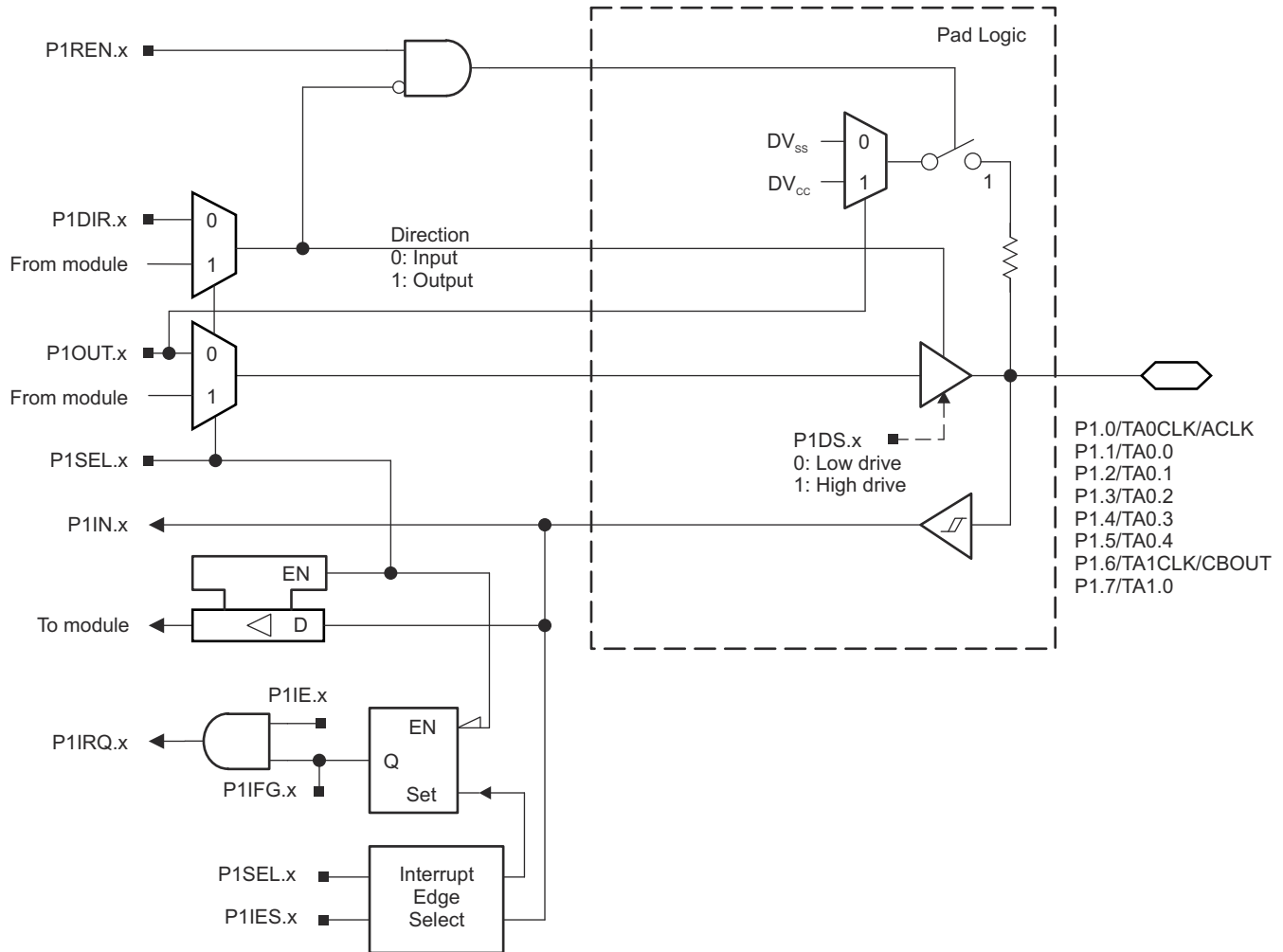

Figure 9-2. Port P1 (P1.0 to P1.7) Diagram

Table 9-46. Port P1 (P1.0 to P1.7) Pin Functions

PIN NAME (P1.x)	x	FUNCTION	CONTROL BITS OR SIGNALS	
			P1DIR.x	P1SEL.x
P1.0/TA0CLK/ACLK	0	P1.0 (I/O)	I: 0; O: 1	0
		TA0CLK	0	1
		ACLK	1	1
P1.1/TA0.0	1	P1.1 (I/O)	I: 0; O: 1	0
		TA0.CCI0A	0	1
		TA0.0	1	1
P1.2/TA0.1	2	P1.2 (I/O)	I: 0; O: 1	0
		TA0.CCI1A	0	1
		TA0.1	1	1
P1.3/TA0.2	3	P1.3 (I/O)	I: 0; O: 1	0
		TA0.CCI2A	0	1
		TA0.2	1	1
P1.4/TA0.3	4	P1.4 (I/O)	I: 0; O: 1	0
		TA0.CCI3A	0	1
		TA0.3	1	1
P1.5/TA0.4	5	P1.5 (I/O)	I: 0; O: 1	0
		TA0.CCI4A	0	1
		TA0.4	1	1
P1.6/TA1CLK/CBOUT	6	P1.6 (I/O)	I: 0; O: 1	0
		TA1CLK	0	1
		CBOUT comparator B	1	1
P1.7/TA1.0	7	P1.7 (I/O)	I: 0; O: 1	0
		TA1.CCI0A	0	1
		TA1.0	1	1

9.10.2 Port P2 (P2.0 to P2.7) Input/Output With Schmitt Trigger

Figure 9-3 shows the port diagram. Table 9-47 summarizes the selection of the pin function.

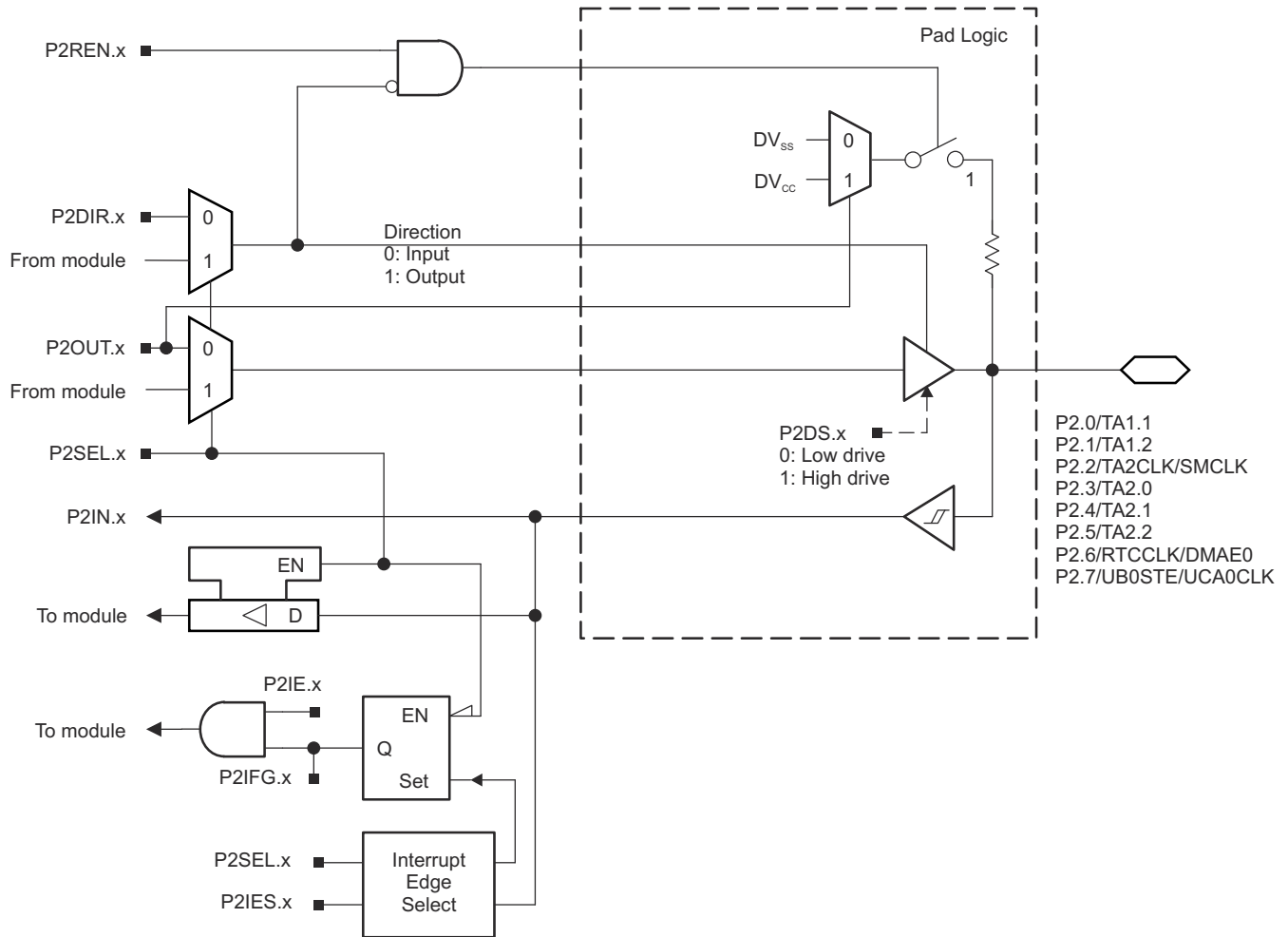

Figure 9-3. Port P2 (P2.0 to P2.7) Diagram

Table 9-47. Port P2 (P2.0 to P2.7) Pin Functions

PIN NAME (P2.x)	x	FUNCTION	CONTROL BITS OR SIGNALS ⁽¹⁾	
			P2DIR.x	P2SEL.x
P2.0/TA1.1	0	P2.0 (I/O)	I: 0; O: 1	0
		TA1.CCI1A	0	1
		TA1.1	1	1
P2.1/TA1.2	1	P2.1 (I/O)	I: 0; O: 1	0
		TA1.CCI2A	0	1
		TA1.2	1	1
P2.2/TA2CLK/SMCLK	2	P2.2 (I/O)	I: 0; O: 1	0
		TA2CLK	0	1
		SMCLK	1	1
P2.3/TA2.0	3	P2.3 (I/O)	I: 0; O: 1	0
		TA2.CCI0A	0	1
		TA2.0	1	1
P2.4/TA2.1	4	P2.4 (I/O)	I: 0; O: 1	0
		TA2.CCI1A	0	1
		TA2.1	1	1
P2.5/TA2.2	5	P2.5 (I/O)	I: 0; O: 1	0
		TA2.CCI2A	0	1
		TA2.2	1	1
P2.6/RTCCLK/DMAE0	6	P2.6 (I/O)	I: 0; O: 1	0
		DMAE0	0	1
		RTCCLK	1	1
P2.7/UCB0STE/UCA0CLK	7	P2.7 (I/O)	I: 0; O: 1	0
		UCB0STE/UCA0CLK ^{(2) (3)}	X	1

(1) X = Don't care

(2) The pin direction is controlled by the USCI module.

(3) UCA0CLK function takes precedence over UCB0STE function. If the pin is required as UCA0CLK input or output, USCI B0 is forced to 3-wire SPI mode if 4-wire SPI mode is selected.

9.10.3 Port P3 (P3.0 to P3.7) Input/Output With Schmitt Trigger

Figure 9-4 shows the port diagram. Table 9-48 summarizes the selection of the pin function.

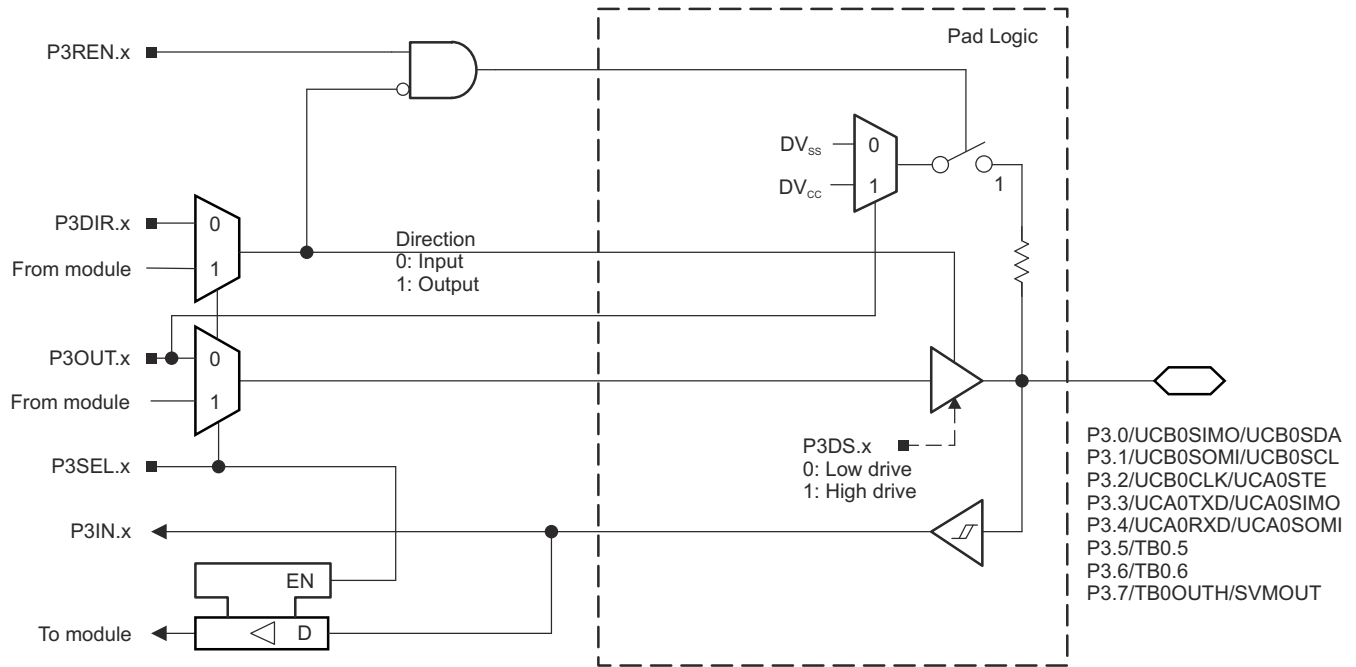

Figure 9-4. Port P3 (P3.0 to P3.7) Diagram

Table 9-48. Port P3 (P3.0 to P3.7) Pin Functions

PIN NAME (P3.x)	x	FUNCTION	CONTROL BITS OR SIGNALS ⁽¹⁾	
			P3DIR.x	P3SEL.x
P3.0/UCB0SIMO/UCB0SDA	0	P3.0 (I/O)	I: 0; O: 1	0
		UCB0SIMO/UCB0SDA ^{(2) (3)}	X	1
P3.1/UCB0SOMI/UCB0SCL	1	P3.1 (I/O)	I: 0; O: 1	0
		UCB0SOMI/UCB0SCL ^{(2) (3)}	X	1
P3.2/UCB0CLK/UCA0STE	2	P3.2 (I/O)	I: 0; O: 1	0
		UCB0CLK/UCA0STE ^{(2) (4)}	X	1
P3.3/UCA0TXD/UCA0SIMO	3	P3.3 (I/O)	I: 0; O: 1	0
		UCA0TXD/UCA0SIMO ⁽²⁾	X	1
P3.4/UCA0RXD/UCA0SOMI	4	P3.4 (I/O)	I: 0; O: 1	0
		UCA0RXD/UCA0SOMI ⁽²⁾	X	1
P3.5/TB0.5 ⁽⁵⁾	5	P3.5 (I/O)	I: 0; O: 1	0
		TB0.CCI5A	0	1
		TB0.5	1	1
P3.6/TB0.6 ⁽⁵⁾	6	P3.6 (I/O)	I: 0; O: 1	0
		TB0.CCI6A	0	1
		TB0.6	1	1
P3.7/TB0OUTH/SVMOUT ⁽⁵⁾	7	P3.7 (I/O)	I: 0; O: 1	0
		TB0OUTH	0	1
		SVMOUT	1	1

(1) X = Don't care

(2) The pin direction is controlled by the USCI module.

(3) If the I²C functionality is selected, the output drives only the logical 0 to V_{SS} level.

(4) UCB0CLK function takes precedence over UCA0STE function. If the pin is required as UCB0CLK input or output, USCI A0 is forced to 3-wire SPI mode if 4-wire SPI mode is selected.

(5) F5529, F5527, F5525, F5521, F5519, F5517, F5515 devices only.

9.10.4 Port P4 (P4.0 to P4.7) Input/Output With Schmitt Trigger

Figure 9-5 shows the port diagram. Table 9-49 summarizes the selection of the pin function.

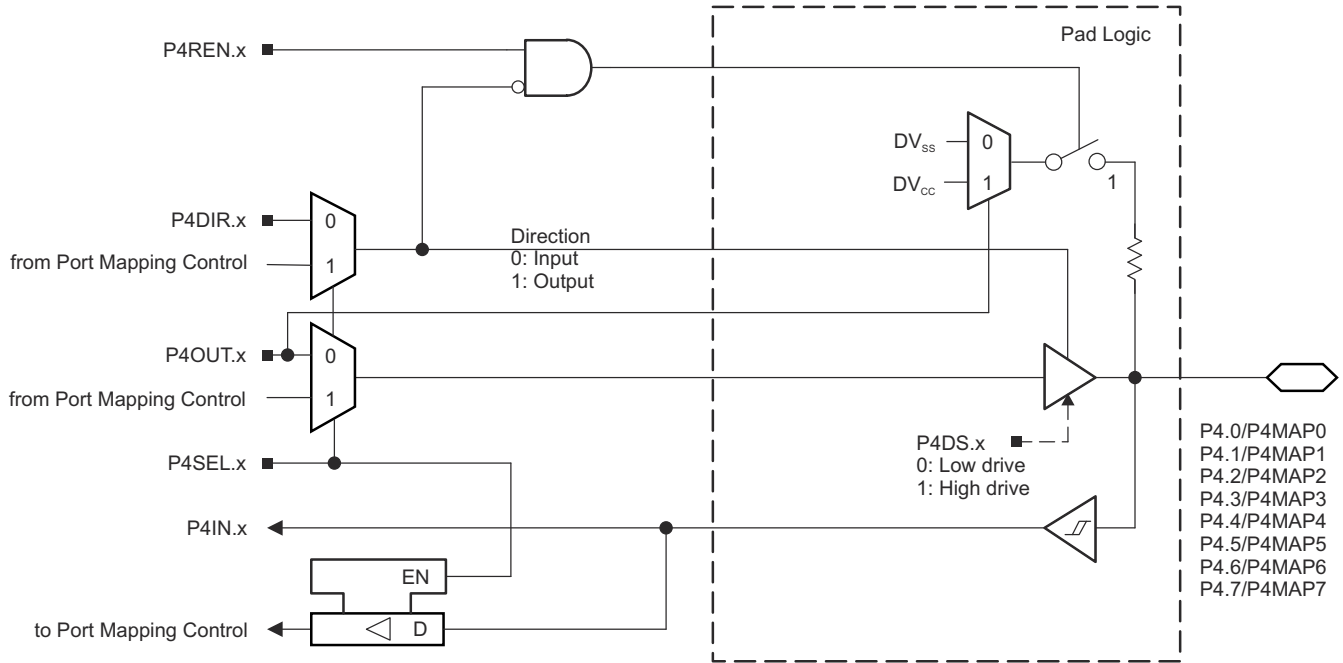

Figure 9-5. Port P4 (P4.0 to P4.7) Diagram

Table 9-49. Port P4 (P4.0 to P4.7) Pin Functions

PIN NAME (P4.x)	x	FUNCTION	CONTROL BITS OR SIGNALS		
			P4DIR.x ⁽¹⁾	P4SEL.x	P4MAPx
P4.0/P4MAP0	0	P4.0 (I/O)	I: 0; O: 1	0	X
		Mapped secondary digital function	X	1	≤ 30
P4.1/P4MAP1	1	P4.1 (I/O)	I: 0; O: 1	0	X
		Mapped secondary digital function	X	1	≤ 30
P4.2/P4MAP2	2	P4.2 (I/O)	I: 0; O: 1	0	X
		Mapped secondary digital function	X	1	≤ 30
P4.3/P4MAP3	3	P4.3 (I/O)	I: 0; O: 1	0	X
		Mapped secondary digital function	X	1	≤ 30
P4.4/P4MAP4	4	P4.4 (I/O)	I: 0; O: 1	0	X
		Mapped secondary digital function	X	1	≤ 30
P4.5/P4MAP5	5	P4.5 (I/O)	I: 0; O: 1	0	X
		Mapped secondary digital function	X	1	≤ 30
P4.6/P4MAP6	6	P4.6 (I/O)	I: 0; O: 1	0	X
		Mapped secondary digital function	X	1	≤ 30
P4.7/P4MAP7	7	P4.7 (I/O)	I: 0; O: 1	0	X
		Mapped secondary digital function	X	1	≤ 30

(1) The direction of some mapped secondary functions are controlled directly by the module. See Table 9-7 for specific direction control information of mapped secondary functions.

Table 9-50. Port P5 (P5.0 and P5.1) Pin Functions

PIN NAME (P5.x)	x	FUNCTION	CONTROL BITS OR SIGNALS ⁽³⁾		
			P5DIR.x	P5SEL.x	REFOUT
P5.0/A8/VREF+/VeREF+ ⁽¹⁾	0	P5.0 (I/O) ⁽⁴⁾	I: 0; O: 1	0	X
		A8/VeREF+ ⁽⁵⁾	X	1	0
		A8/VREF+ ⁽⁶⁾	X	1	1
P5.1/A9/VREF-/VeREF- ⁽²⁾	1	P5.1 (I/O) ⁽⁴⁾	I: 0; O: 1	0	X
		A9/VeREF- ⁽⁷⁾	X	1	0
		A9/VREF- ⁽⁸⁾	X	1	1

(1) VREF+/VeREF+ available on MSP430F552x devices only.

(2) VREF-/VeREF- available on MSP430F552x devices only.

(3) X = Don't care

(4) Default condition

(5) Setting the P5SEL.0 bit disables the output driver and the input Schmitt trigger to prevent parasitic cross currents when applying analog signals. An external voltage can be applied to VeREF+ and used as the reference for the ADC12_A when available. Channel A8, when selected with the INCHx bits, is connected to the VREF+/VeREF+ pin.

(6) Setting the P5SEL.0 bit disables the output driver and the input Schmitt trigger to prevent parasitic cross currents when applying analog signals. The VREF+ reference is available at the pin. Channel A8, when selected with the INCHx bits, is connected to the VREF+/VeREF+ pin.

(7) Setting the P5SEL.1 bit disables the output driver and the input Schmitt trigger to prevent parasitic cross currents when applying analog signals. An external voltage can be applied to VeREF- and used as the reference for the ADC12_A when available. Channel A9, when selected with the INCHx bits, is connected to the VREF-/VeREF- pin.

(8) Setting the P5SEL.1 bit disables the output driver and the input Schmitt trigger to prevent parasitic cross currents when applying analog signals. The VREF- reference is available at the pin. Channel A9, when selected with the INCHx bits, is connected to the VREF-/VeREF- pin.

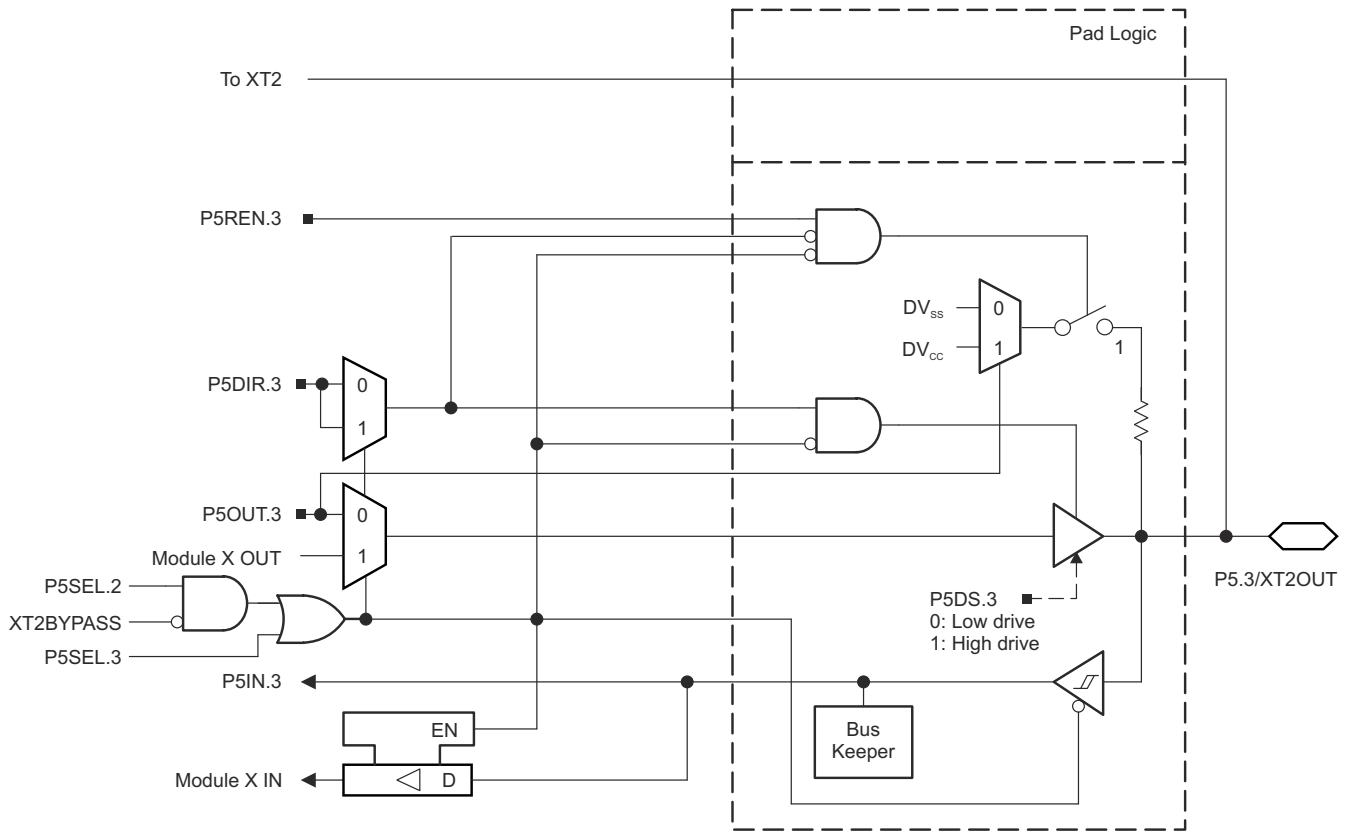

Figure 9-8. Port P5 (P5.3) Diagram

Table 9-51. Port P5 (P5.2 and P5.3) Pin Functions

PIN NAME (P5.x)	x	FUNCTION	CONTROL BITS OR SIGNALS ⁽¹⁾			
			P5DIR.x	P5SEL.2	P5SEL.3	XT2BYPASS
P5.2/XT2IN	2	P5.2 (I/O)	I: 0; O: 1	0	X	X
		XT2IN crystal mode ⁽²⁾	X	1	X	0
		XT2IN bypass mode ⁽²⁾	X	1	X	1
P5.3/XT2OUT	3	P5.3 (I/O)	I: 0; O: 1	0	0	X
		XT2OUT crystal mode ⁽³⁾	X	1	X	0
		P5.3 (I/O) ⁽³⁾	X	1	0	1

- (1) X = Don't care
- (2) Setting P5SEL.2 causes the general-purpose I/O to be disabled. Pending the setting of XT2BYPASS, P5.2 is configured for crystal mode or bypass mode.
- (3) Setting P5SEL.2 causes the general-purpose I/O to be disabled in crystal mode. When using bypass mode, P5.3 can be used as general-purpose I/O.

9.10.9 Port P6 (P6.0 to P6.7) Input/Output With Schmitt Trigger

Figure 9-12 shows the port diagram. Table 9-54 summarizes the selection of the pin function.

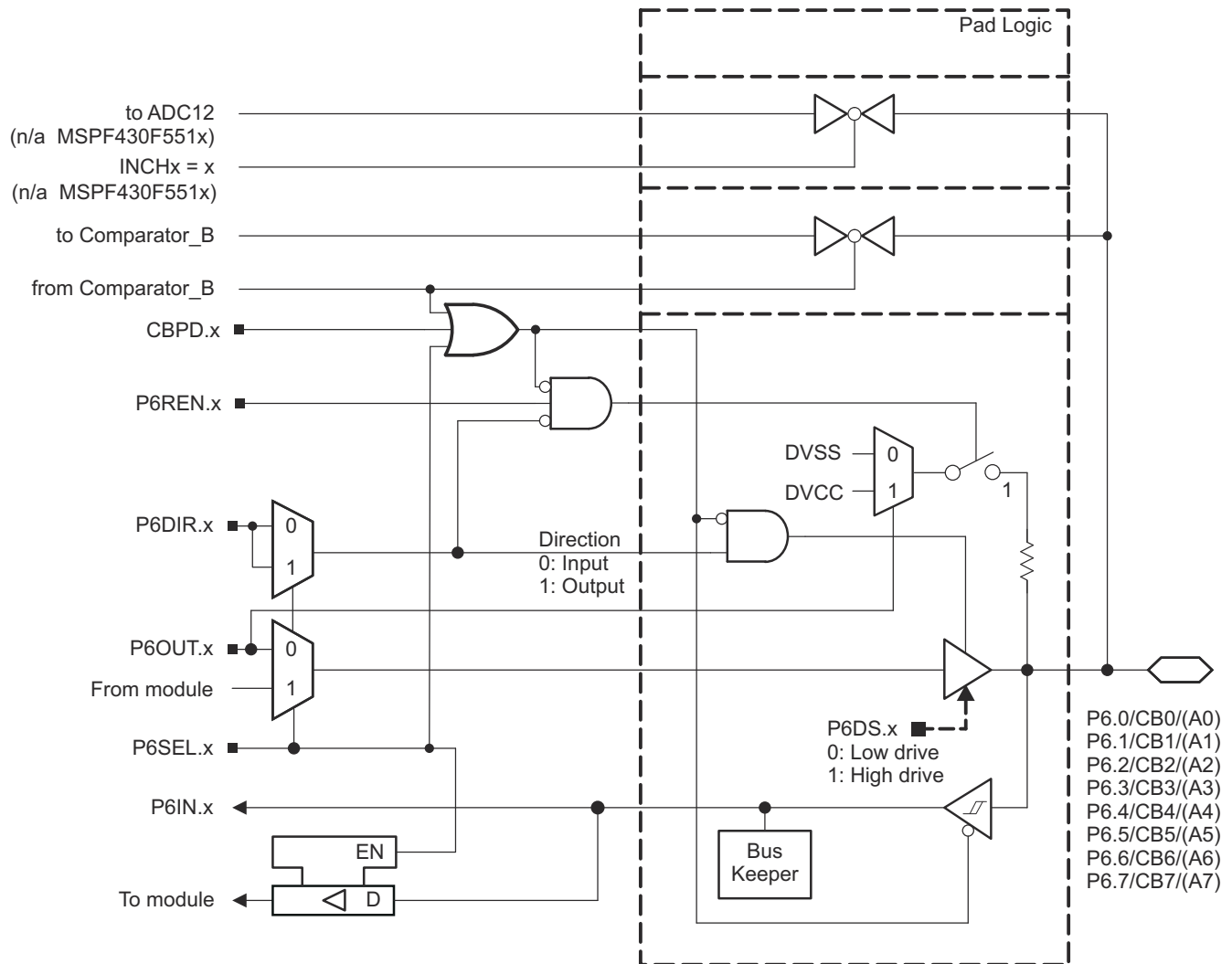

Figure 9-12. Port P6 (P6.0 to P6.7) Diagram

Table 9-54. Port P6 (P6.0 to P6.7) Pin Functions

PIN NAME (P6.x)	x	FUNCTION	CONTROL BITS OR SIGNALS		
			P6DIR.x	P6SEL.x	CBPD
P6.0/CB0/(A0)	0	P6.0 (I/O)	I: 0; O: 1	0	0
		A0 (only MSP430F552x)	X	1	X
		CB0 ⁽¹⁾	X	X	1
P6.1/CB1/(A1)	1	P6.1 (I/O)	I: 0; O: 1	0	0
		A1 (only MSP430F552x)	X	1	X
		CB1 ⁽¹⁾	X	X	1
P6.2/CB2/(A2)	2	P6.2 (I/O)	I: 0; O: 1	0	0
		A2 (only MSP430F552x)	X	1	X
		CB2 ⁽¹⁾	X	X	1
P6.3/CB3/(A3)	3	P6.3 (I/O)	I: 0; O: 1	0	0
		A3 (only MSP430F552x)	X	1	X
		CB3 ⁽¹⁾	X	X	1
P6.4/CB4/(A4)	4	P6.4 (I/O)	I: 0; O: 1	0	0
		A4 (only MSP430F552x)	X	1	X
		CB4 ⁽¹⁾	X	X	1
P6.5/CB5/(A5)	5	P6.5 (I/O)	I: 0; O: 1	0	0
		A5 (only MSP430F552x)	X	1	X
		CB5 ⁽¹⁾	X	X	1
P6.6/CB6/(A6)	6	P6.6 (I/O)	I: 0; O: 1	0	0
		A6 (only MSP430F552x)	X	1	X
		CB6 ⁽¹⁾	X	X	1
P6.7/CB7/(A7)	7	P6.7 (I/O)	I: 0; O: 1	0	0
		A7 (only MSP430F552x)	X	1	X
		CB7 ⁽¹⁾	X	X	1

- (1) Setting the CBPD.x bit disables the output driver and the input Schmitt trigger to prevent parasitic cross currents when applying analog signals. Selecting the CBx input pin to the comparator multiplexer with the CBx bits automatically disables output driver and input buffer for that pin, regardless of the state of the associated CBPD.x bit.

Table 9-55. Port P7 (P7.0 to P7.3) Pin Functions

PIN NAME (P7.x)	x	FUNCTION	CONTROL BITS OR SIGNALS		
			P7DIR.x	P7SEL.x	CBPD
P7.0/CB8/(A12)	0	P7.0 (I/O) ⁽¹⁾	I: 0; O: 1	0	0
		A12 ⁽²⁾	X	1	X
		CB8 ⁽³⁾ ⁽¹⁾	X	X	1
P7.1/CB9/(A13)	1	P7.1 (I/O) ⁽¹⁾	I: 0; O: 1	0	0
		A13 ⁽²⁾	X	1	X
		CB9 ⁽³⁾ ⁽¹⁾	X	X	1
P7.2/CB10/(A14)	2	P7.2 (I/O) ⁽¹⁾	I: 0; O: 1	0	0
		A14 ⁽²⁾	X	1	X
		CB10 ⁽³⁾ ⁽¹⁾	X	X	1
P7.3/CB11/(A15)	3	P7.3 (I/O) ⁽¹⁾	I: 0; O: 1	0	0
		A15 ⁽²⁾	X	1	X
		CB11 ⁽³⁾ ⁽¹⁾	X	X	1

(1) F5529, F5527, F5525, F5521, F5519, F5517, F5515 devices only

(2) F5529, F5527, F5525, F5521 devices only

(3) Setting the CBPD.x bit disables the output driver and the input Schmitt trigger to prevent parasitic cross currents when applying analog signals. Selecting the CBx input pin to the comparator multiplexer with the CBx bits automatically disables output driver and input buffer for that pin, regardless of the state of the associated CBPD.x bit.

9.10.12 Port P8 (P8.0 to P8.2) Input/Output With Schmitt Trigger

Figure 9-15 shows the port diagram. Table 9-57 summarizes the selection of the pin function.

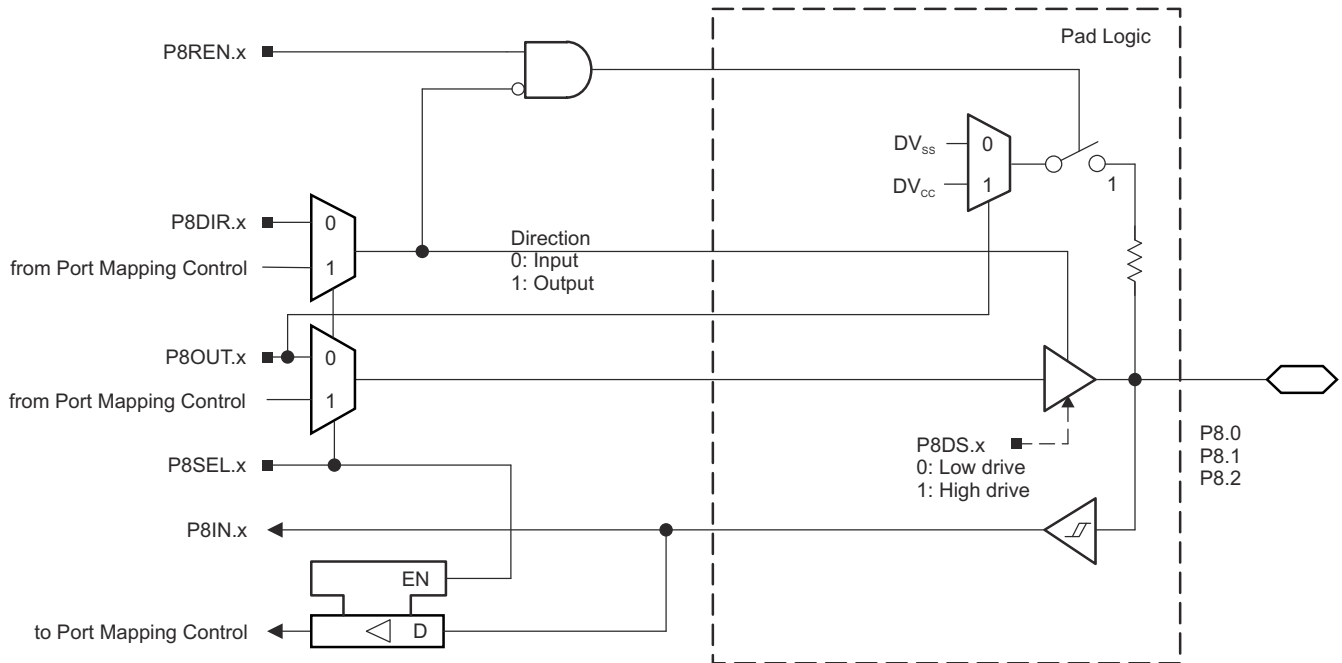

Figure 9-15. Port P8 (P8.0 to P8.2) Diagram

Table 9-57. Port P8 (P8.0 to P8.2) Pin Functions

PIN NAME (P8.x)	x	FUNCTION	CONTROL BITS OR SIGNALS	
			P8DIR.x	P8SEL.x
P8.0 ⁽¹⁾	0	P8.0(I/O)	I: 0; O: 1	0
P8.1 ⁽¹⁾	1	P8.1(I/O)	I: 0; O: 1	0
P8.2 ⁽¹⁾	2	P8.2(I/O)	I: 0; O: 1	0

(1) F5529, F5527, F5525, F5521, F5519, F5517, F5515 devices only

9.10.13 Port PU (PU.0/DP, PU.1/DM, PUR) USB Ports

Figure 9-16 shows the port diagram. Table 9-58 through Table 9-60 summarize the pin function selection.

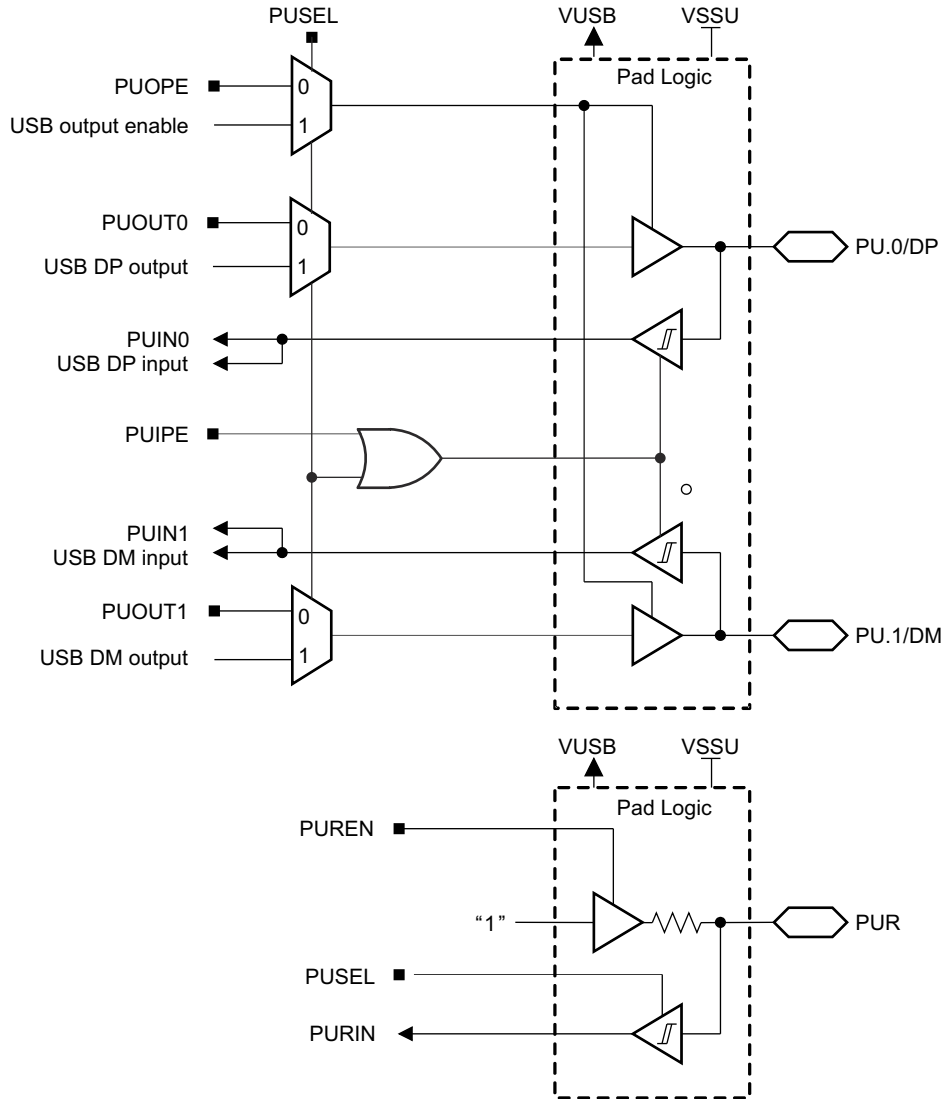

Figure 9-16. Port PU (PU.0/DP, PU.1/DM) Diagram

Table 9-58. Port PU (PU.0/DP, PU.1/DM) Output Functions

CONTROL BITS ⁽¹⁾				PIN NAME	
PUSEL	PUOPE	PUOUT1	PUOUT0	PU.1/DM	PU.0/DP
0	0	X	X	Output disabled	Output disabled
0	1	0	0	Output low	Output low
0	1	0	1	Output low	Output high
0	1	1	0	Output high	Output low
0	1	1	1	Output high	Output high
1	X	X	X	DM ⁽²⁾	DP ⁽²⁾

- (1) PU.1/DM and PU.0/DP inputs and outputs are supplied from VUSB. VUSB can be generated by the device using the integrated 3.3-V LDO when enabled. VUSB can also be supplied externally when the 3.3-V LDO is not being used and is disabled.
- (2) Output state set by the USB module.

Table 9-59. Port PU (PU.0/DP, PU.1/DM) Input Functions

CONTROL BITS ⁽¹⁾		PIN NAME	
PUSEL	PUIPE	PU.1/DM	PU.0/DP
0	0	Input disabled	Input disabled
0	1	Input enabled	Input enabled
1	X	DM input	DP input

- (1) PU.1/DM and PU.0/DP inputs and outputs are supplied from VUSB. VUSB can be generated by the device using the integrated 3.3-V LDO when enabled. VUSB can also be supplied externally when the 3.3-V LDO is not being used and is disabled.

Table 9-60. Port PUR Input Functions

CONTROL BITS		FUNCTION
PUSEL	PUREN	
0	0	Input disabled Pullup disabled
0	1	Input disabled Pullup enabled
1	0	Input enabled Pullup disabled
1	1	Input enabled Pullup enabled

9.10.14 Port PJ (PJ.0) JTAG Pin TDO, Input/Output With Schmitt Trigger or Output

Figure 9-17 shows the port diagram. Table 9-61 summarizes the selection of the pin function.

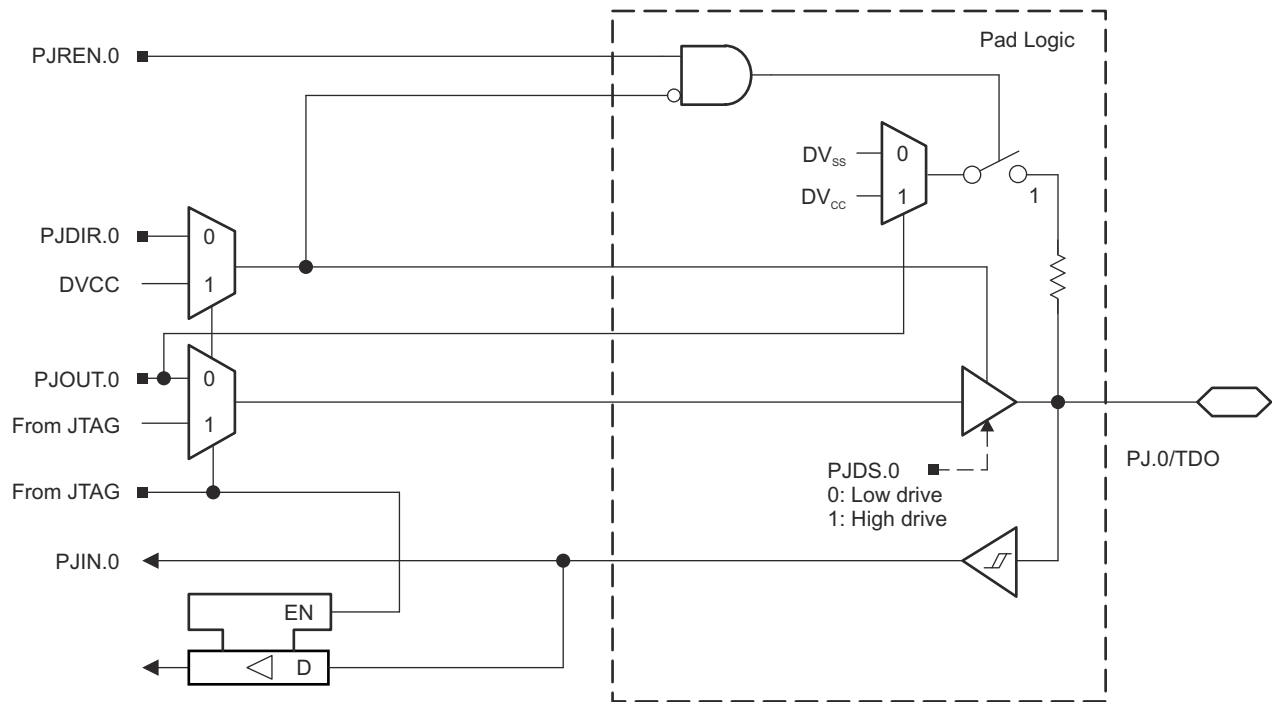

Figure 9-17. Port J (PJ.0) Diagram

9.11 Device Descriptors (TLV)

Table 9-62 and Table 9-63 list the complete contents of the device descriptor tag-length-value (TLV) structure for each device type.

Table 9-62. MSP430F552x Device Descriptor Table

DESCRIPTION ⁽¹⁾		ADDRESS	SIZE (bytes)	VALUE								
				F5529	F5528	F5527	F5526	F5525	F5524	F5522	F5521	
Info Block	Info length	01A00h	1	06h	06h	06h	06h	06h	06h	06h	06h	06h
	CRC length	01A01h	1	06h	06h	06h	06h	06h	06h	06h	06h	06h
	CRC value	01A02h	2	Per unit	Per unit	Per unit	Per unit	Per unit	Per unit	Per unit	Per unit	Per unit
	Device ID	01A04h	1	55h	55h	55h	55h	55h	55h	55h	55h	55h
	Device ID	01A05h	1	29h	28h	27h	26h	25h	24h	22h	21h	
	Hardware revision	01A06h	1	Per unit	Per unit	Per unit	Per unit	Per unit	Per unit	Per unit	Per unit	Per unit
	Firmware revision	01A07h	1	Per unit	Per unit	Per unit	Per unit	Per unit	Per unit	Per unit	Per unit	Per unit
Die Record	Die record tag	01A08h	1	08h	08h	08h	08h	08h	08h	08h	08h	08h
	Die record length	01A09h	1	0Ah	0Ah	0Ah	0Ah	0Ah	0Ah	0Ah	0Ah	0Ah
	Lot/wafer ID	01A0Ah	4	Per unit	Per unit	Per unit	Per unit	Per unit	Per unit	Per unit	Per unit	Per unit
	Die X position	01A0Eh	2	Per unit	Per unit	Per unit	Per unit	Per unit	Per unit	Per unit	Per unit	Per unit
	Die Y position	01A10h	2	Per unit	Per unit	Per unit	Per unit	Per unit	Per unit	Per unit	Per unit	Per unit
	Test results	01A12h	2	Per unit	Per unit	Per unit	Per unit	Per unit	Per unit	Per unit	Per unit	Per unit
ADC12 Calibration	ADC12 calibration tag	01A14h	1	11h	11h	11h	11h	11h	11h	11h	11h	11h
	ADC12 calibration length	01A15h	1	10h	10h	10h	10h	10h	10h	10h	10h	10h
	ADC gain factor	01A16h	2	Per unit	Per unit	Per unit	Per unit	Per unit	Per unit	Per unit	Per unit	Per unit
	ADC offset	01A18h	2	Per unit	Per unit	Per unit	Per unit	Per unit	Per unit	Per unit	Per unit	Per unit
	ADC 1.5-V reference Temperature sensor 30°C	01A1Ah	2	Per unit	Per unit	Per unit	Per unit	Per unit	Per unit	Per unit	Per unit	Per unit
	ADC 1.5-V reference Temperature sensor 85°C	01A1Ch	2	Per unit	Per unit	Per unit	Per unit	Per unit	Per unit	Per unit	Per unit	Per unit
	ADC 2.0-V reference Temperature sensor 30°C	01A1Eh	2	Per unit	Per unit	Per unit	Per unit	Per unit	Per unit	Per unit	Per unit	Per unit
	ADC 2.0-V reference Temperature sensor 85°C	01A20h	2	Per unit	Per unit	Per unit	Per unit	Per unit	Per unit	Per unit	Per unit	Per unit
	ADC 2.5-V reference Temperature sensor 30°C	01A22h	2	Per unit	Per unit	Per unit	Per unit	Per unit	Per unit	Per unit	Per unit	Per unit
	ADC 2.5-V reference Temperature sensor 85°C	01A24h	2	Per unit	Per unit	Per unit	Per unit	Per unit	Per unit	Per unit	Per unit	Per unit
REF Calibration	REF calibration tag	01A26h	1	12h	12h	12h	12h	12h	12h	12h	12h	12h
	REF calibration length	01A27h	1	06h	06h	06h	06h	06h	06h	06h	06h	06h
	REF 1.5-V reference factor	01A28h	2	Per unit	Per unit	Per unit	Per unit	Per unit	Per unit	Per unit	Per unit	Per unit
	REF 2.0-V reference factor	01A2Ah	2	Per unit	Per unit	Per unit	Per unit	Per unit	Per unit	Per unit	Per unit	Per unit
	REF 2.5-V reference factor	01A2Ch	2	Per unit	Per unit	Per unit	Per unit	Per unit	Per unit	Per unit	Per unit	Per unit
Peripheral Descriptor	Peripheral descriptor tag	01A2Eh	1	02h	02h	02h	02h	02h	02h	02h	02h	02h
	Peripheral descriptor length	01A2Fh	1	63h	61h	65h	63h	63h	61h	61h	64h	
	Memory 1		2	08h 8Ah	08h 8Ah	08h 8Ah	08h 8Ah	08h 8Ah	08h 8Ah	08h 8Ah	08h 8Ah	08h 8Ah
	Memory 2		2	0Ch 86h	0Ch 86h	0Ch 86h	0Ch 86h	0Ch 86h	0Ch 86h	0Ch 86h	0Ch 86h	0Ch 86h
	Memory 3		2	0Eh 2Ah	0Eh 2Ah	0Eh 2Ah	0Eh 2Ah	0Eh 2Ah	0Eh 2Ah	0Eh 2Ah	0Eh 2Ah	0Eh 2Ah
	Memory 4		2	12h 2Eh	12h 2Eh	12h 2Dh	12h 2Dh	12h 2Ch	12h 2Ch	12h 2Eh	12h 2Dh	

Table 9-62. MSP430F552x Device Descriptor Table (continued)

DESCRIPTION ⁽¹⁾	ADDRESS	SIZE (bytes)	VALUE								
			F5529	F5528	F5527	F5526	F5525	F5524	F5522	F5521	
Memory 5		2	22h 96h	22h 96h	2Ah 22h	2Ah 22h	22h 94h	22h 94h	40h 92h	2Ah 40h	
Memory 6		1/2	N/A	N/A	95h 92h	95h 92h	N/A	N/A	N/A	92h	
Delimiter		1	00h	00h	00h	00h	00h	00h	00h	00h	
Peripheral count		1	21h	20h	21h	20h	21h	20h	20h	21h	
MSP430CPUXV2		2	00h 23h	00h 23h	00h 23h	00h 23h	00h 23h	00h 23h	00h 23h	00h 23h	
JTAG		2	00h 09h	00h 09h	00h 09h	00h 09h	00h 09h	00h 09h	00h 09h	00h 09h	
SBW		2	00h 0Fh	00h 0Fh	00h 0Fh	00h 0Fh	00h 0Fh	00h 0Fh	00h 0Fh	00h 0Fh	
EEM-L		2	00h 05h	00h 05h	00h 05h	00h 05h	00h 05h	00h 05h	00h 05h	00h 05h	
TI BSL		2	00h FCh	00h FCh	00h FCh	00h FCh	00h FCh	00h FCh	00h FCh	00h FCh	
SFR		2	10h 41h	10h 41h	10h 41h	10h 41h	10h 41h	10h 41h	10h 41h	10h 41h	
PMM		2	02h 30h	02h 30h	02h 30h	02h 30h	02h 30h	02h 30h	02h 30h	02h 30h	
FCTL		2	02h 38h	02h 38h	02h 38h	02h 38h	02h 38h	02h 38h	02h 38h	02h 38h	
CRC16		2	01h 3Ch	01h 3Ch	01h 3Ch	01h 3Ch	01h 3Ch	01h 3Ch	01h 3Ch	01h 3Ch	
CRC16_RB		2	00h 3Dh	00h 3Dh	00h 3Dh	00h 3Dh	00h 3Dh	00h 3Dh	00h 3Dh	00h 3Dh	
RAMCTL		2	00h 44h	00h 44h	00h 44h	00h 44h	00h 44h	00h 44h	00h 44h	00h 44h	
WDT_A		2	00h 40h	00h 40h	00h 40h	00h 40h	00h 40h	00h 40h	00h 40h	00h 40h	
UCS		2	01h 48h	01h 48h	01h 48h	01h 48h	01h 48h	01h 48h	01h 48h	01h 48h	
SYS		2	02h 42h	02h 42h	02h 42h	02h 42h	02h 42h	02h 42h	02h 42h	02h 42h	
REF		2	03h A0h	03h A0h	03h A0h	03h A0h	03h A0h	03h A0h	03h A0h	03h A0h	
Port mapping		2	01h 10h	01h 10h	01h 10h	01h 10h	01h 10h	01h 10h	01h 10h	01h 10h	
Port 1 and 2		2	04h 51h	04h 51h	04h 51h	04h 51h	04h 51h	04h 51h	04h 51h	04h 51h	
Port 3 and 4		2	02h 52h	02h 52h	02h 52h	02h 52h	02h 52h	02h 52h	02h 52h	02h 52h	
Port 5 and 6		2	02h 53h	02h 53h	02h 53h	02h 53h	02h 53h	02h 53h	02h 53h	02h 53h	
Port 7 and 8		2	02h 54h	N/A	02h 54h	N/A	02h 54h	N/A	N/A	02h 54h	
Peripheral Descriptor (continued)	JTAG	2	0Ch 5Fh	0Eh 5Fh	0Ch 5Fh	0Eh 5Fh	0Ch 5Fh	0Eh 5Fh	0Eh 5Fh	0Ch 5Fh	
	TA0	2	02h 62h	02h 62h	02h 62h	02h 62h	02h 62h	02h 62h	02h 62h	02h 62h	
	TA1	2	04h 61h	04h 61h	04h 61h	04h 61h	04h 61h	04h 61h	04h 61h	04h 61h	
	TB0	2	04h 67h	04h 67h	04h 67h	04h 67h	04h 67h	04h 67h	04h 67h	04h 67h	
	TA2	2	04h 61h	04h 61h	04h 61h	04h 61h	04h 61h	04h 61h	04h 61h	04h 61h	
	RTC	2	0Ah 68h	0Ah 68h	0Ah 68h	0Ah 68h	0Ah 68h	0Ah 68h	0Ah 68h	0Ah 68h	

Table 9-62. MSP430F552x Device Descriptor Table (continued)

DESCRIPTION ⁽¹⁾	ADDRESS	SIZE (bytes)	VALUE								
			F5529	F5528	F5527	F5526	F5525	F5524	F5522	F5521	
MPY32		2	02h 85h	02h 85h	02h 85h	02h 85h	02h 85h	02h 85h	02h 85h	02h 85h	02h 85h
DMA-3		2	04h 47h	04h 47h	04h 47h	04h 47h	04h 47h	04h 47h	04h 47h	04h 47h	04h 47h
USCI_A and USCI_B		2	0Ch 90h	0Ch 90h	0Ch 90h	0Ch 90h	0Ch 90h	0Ch 90h	0Ch 90h	0Ch 90h	0Ch 90h
USCI_A and USCI_B		2	04h 90h	04h 90h	04h 90h	04h 90h	04h 90h	04h 90h	04h 90h	04h 90h	04h 90h
ADC12_A		2	10h D1h	10h D1h	10h D1h	10h D1h	10h D1h	10h D1h	10h D1h	10h D1h	10h D1h
COMP_B		2	1Ch A8h	1Ch A8h	1Ch A8h	1Ch A8h	1Ch A8h	1Ch A8h	1Ch A8h	1Ch A8h	1Ch A8h
USB		2	04h 98h	04h 98h	04h 98h	04h 98h	04h 98h	04h 98h	04h 98h	04h 98h	04h 98h
Interrupts	COMP_B	1	A8h	A8h	A8h	A8h	A8h	A8h	A8h	A8h	A8h
	TB0.CCIFG0	1	64h	64h	64h	64h	64h	64h	64h	64h	64h
	TB0.CCIFG1..6	1	65h	65h	65h	65h	65h	65h	65h	65h	65h
	WDTIFG	1	40h	40h	40h	40h	40h	40h	40h	40h	40h
	USCI_A0	1	90h	90h	90h	90h	90h	90h	90h	90h	90h
	USCI_B0	1	91h	91h	91h	91h	91h	91h	91h	91h	91h
	ADC12_A	1	D0h	D0h	D0h	D0h	D0h	D0h	D0h	D0h	D0h
	TA0.CCIFG0	1	60h	60h	60h	60h	60h	60h	60h	60h	60h
	TA0.CCIFG1..4	1	61h	61h	61h	61h	61h	61h	61h	61h	61h
	USB	1	98h	98h	98h	98h	98h	98h	98h	98h	98h
	DMA	1	46h	46h	46h	46h	46h	46h	46h	46h	46h
	TA1.CCIFG0	1	62h	62h	62h	62h	62h	62h	62h	62h	62h
	TA1.CCIFG1..2	1	63h	63h	63h	63h	63h	63h	63h	63h	63h
	P1	1	50h	50h	50h	50h	50h	50h	50h	50h	50h
	USCI_A1	1	92h	92h	92h	92h	92h	92h	92h	92h	92h
	USCI_B1	1	93h	93h	93h	93h	93h	93h	93h	93h	93h
	TA1.CCIFG0	1	66h	66h	66h	66h	66h	66h	66h	66h	66h
	TA1.CCIFG1..2	1	67h	67h	67h	67h	67h	67h	67h	67h	67h
	P2	1	51h	51h	51h	51h	51h	51h	51h	51h	51h
RTC_A	1	68h	68h	68h	68h	68h	68h	68h	68h	68h	
Delimiter		1	00h	00h	00h	00h	00h	00h	00h	00h	00h

(1) N/A = Not applicable, blank = unused and reads FFh.

Table 9-63. MSP430F551x Device Descriptor Table

DESCRIPTION ⁽¹⁾		ADDRESS	SIZE (bytes)	VALUE				
				F5519	F5517	F5515	F5514	F5513
Info Block	Info length	01A00h	1	55h	55h	55h	55h	55h
	CRC length	01A01h	1	19h	17h	15h	14h	13h
	CRC value	01A02h	2	Per unit	Per unit	Per unit	Per unit	Per unit
	Device ID	01A04h	1	22h	21h	55h	55h	20h
	Device ID	01A05h	1	80h	80h	15h	14h	80h
	Hardware revision	01A06h	1	Per unit	Per unit	Per unit	Per unit	Per unit
	Firmware revision	01A07h	1	Per unit	Per unit	Per unit	Per unit	Per unit
Die Record	Die record tag	01A08h	1	08h	08h	08h	08h	08h
	Die record length	01A09h	1	0Ah	0Ah	0Ah	0Ah	0Ah
	Lot/wafer ID	01A0Ah	4	Per unit	Per unit	Per unit	Per unit	Per unit
	Die X position	01A0Eh	2	Per unit	Per unit	Per unit	Per unit	Per unit
	Die Y position	01A10h	2	Per unit	Per unit	Per unit	Per unit	Per unit
	Test results	01A12h	2	Per unit	Per unit	Per unit	Per unit	Per unit
ADC12 Calibration	ADC12 calibration tag	01A14h	1	05h	05h	11h	11h	05h
	ADC12 calibration length	01A15h	1	10h	10h	10h	10h	10h
	ADC gain factor	01A16h	2	blank	blank	blank	blank	blank
	ADC offset	01A18h	2	blank	blank	blank	blank	blank
	ADC 1.5-V reference Temperature sensor 30°C	01A1Ah	2	blank	blank	blank	blank	blank
	ADC 1.5-V reference Temperature sensor 85°C	01A1Ch	2	blank	blank	blank	blank	blank
	ADC 2.0-V reference Temperature sensor 30°C	01A1Eh	2	blank	blank	blank	blank	blank
	ADC 2.0-V reference Temperature sensor 85°C	01A20h	2	blank	blank	blank	blank	blank
	ADC 2.5-V reference Temperature sensor 30°C	01A22h	2	blank	blank	blank	blank	blank
	ADC 2.5-V reference Temperature sensor 85°C	01A24h	2	blank	blank	blank	blank	blank
REF Calibration	REF calibration tag	01A26h	1	12h	12h	12h	12h	12h
	REF calibration length	01A27h	1	06h	06h	06h	06h	06h
	REF 1.5-V reference factor	01A28h	2	Per unit	Per unit	Per unit	Per unit	Per unit
	REF 2.0-V reference factor	01A2Ah	2	Per unit	Per unit	Per unit	Per unit	Per unit
	REF 2.5-V reference factor	01A2Ch	2	Per unit	Per unit	Per unit	Per unit	Per unit
Peripheral Descriptor	Peripheral descriptor tag	01A2Eh	1	02h	02h	02h	02h	02h
	Peripheral descriptor length	01A2Fh	1	61h	63h	61h	5Fh	5Fh
	Memory 1		2	08h 8Ah	08h 8Ah	08h 8Ah	08h 8Ah	08h 8Ah
	Memory 2		2	0Ch 86h	0Ch 86h	0Ch 86h	0Ch 86h	0Ch 86h
	Memory 3		2	0Eh 2Ah	0Eh 2Ah	0Eh 2Ah	0Eh 2Ah	0Eh 2Ah
	Memory 4		2	12h 2Eh	12h 2Dh	12h 2Ch	12h 2Ch	12h 2Ch
	Memory 5		2	22h 96h	2Ah 22h	22h 94h	22h 94h	40h 92h
	Memory 6		1/2	N/A	95h 92h	N/A	N/A	N/A
	Delimiter		1	00h	00h	00h	00h	00h
	Peripheral count		1	20h	20h	20h	1Fh	1Fh
	MSP430CPUXV2		2	00h 23h	00h 23h	00h 23h	00h 23h	00h 23h
	JTAG		2	00h 09h	00h 09h	00h 09h	00h 09h	00h 09h

Table 9-63. MSP430F551x Device Descriptor Table (continued)

DESCRIPTION ⁽¹⁾	ADDRESS	SIZE (bytes)	VALUE				
			F5519	F5517	F5515	F5514	F5513
SBW		2	00h 0Fh	00h 0Fh	00h 0Fh	00h 0Fh	00h 0Fh
EEM-L		2	00h 05h	00h 05h	00h 05h	00h 05h	00h 05h
TI BSL		2	00h FCh	00h FCh	00h FCh	00h FCh	00h FCh
SFR		2	10h 41h	10h 41h	10h 41h	10h 41h	10h 41h
PMM		2	02h 30h	02h 30h	02h 30h	02h 30h	02h 30h
FCTL		2	02h 38h	02h 38h	02h 38h	02h 38h	02h 38h
CRC16		2	01h 3Ch	01h 3Ch	01h 3Ch	01h 3Ch	01h 3Ch
CRC16_RB		2	00h 3Dh	00h 3Dh	00h 3Dh	00h 3Dh	00h 3Dh
RAMCTL		2	00h 44h	00h 44h	00h 44h	00h 44h	00h 44h
WDT_A		2	00h 40h	00h 40h	00h 40h	00h 40h	00h 40h
UCS		2	01h 48h	01h 48h	01h 48h	01h 48h	01h 48h
SYS		2	02h 42h	02h 42h	02h 42h	02h 42h	02h 42h
REF		2	03h A0h	03h A0h	03h A0h	03h A0h	03h A0h
Port mapping		2	01h 10h	01h 10h	01h 10h	01h 10h	01h 10h
Port 1 and 2		2	04h 51h	04h 51h	04h 51h	04h 51h	04h 51h
Port 3 and 4		2	02h 52h	02h 52h	02h 52h	02h 52h	02h 52h
Port 5 and 6		2	02h 53h	02h 53h	02h 53h	02h 53h	02h 53h
Port 7 and 8		2	02h 54h	02h 54h	02h 54h	N/A	N/A
Peripheral Descriptor (continued)	JTAG	2	0Ch 5Fh	0Ch 5Fh	0Ch 5Fh	0Eh 5Fh	0Eh 5Fh
	TA0	2	02h 62h	02h 62h	02h 62h	02h 62h	02h 62h
	TA1	2	04h 61h	04h 61h	04h 61h	04h 61h	04h 61h
	TB0	2	04h 67h	04h 67h	04h 67h	04h 67h	04h 67h
	TA2	2	04h 61h	04h 61h	04h 61h	04h 61h	04h 61h
	RTC	2	0Ah 68h	0Ah 68h	0Ah 68h	0Ah 68h	0Ah 68h
	MPY32	2	02h 85h	02h 85h	02h 85h	02h 85h	02h 85h
	DMA-3	2	04h 47h	04h 47h	04h 47h	04h 47h	04h 47h
	USCI_A and USCI_B	2	0Ch 90h	0Ch 90h	0Ch 90h	0Ch 90h	0Ch 90h
	USCI_A and USCI_B	2	04h 90h	04h 90h	04h 90h	04h 90h	04h 90h
	ADC12_A	2	N/A	N/A	N/A	N/A	N/A

Table 9-63. MSP430F551x Device Descriptor Table (continued)

DESCRIPTION ⁽¹⁾		ADDRESS	SIZE (bytes)	VALUE				
				F5519	F5517	F5515	F5514	F5513
	COMP_B		2	2Ch A8h	2Ch A8h	2Ch A8h	2Ch A8h	2Ch A8h
	USB		2	04h 98h	04h 98h	04h 98h	04h 98h	04h 98h
Interrupts	COMP_B		1	A8h	A8h	A8h	A8h	A8h
	TB0.CCIFG0		1	64h	64h	64h	64h	64h
	TB0.CCIFG1..6		1	65h	65h	65h	65h	65h
	WDTIFG		1	40h	40h	40h	40h	40h
	USCI_A0		1	90h	90h	90h	90h	90h
	USCI_B0		1	91h	91h	91h	91h	91h
	ADC12_A		1	01h	01h	01h	01h	01h
	TA0.CCIFG0		1	60h	60h	60h	60h	60h
	TA0.CCIFG1..4		1	61h	61h	61h	61h	61h
	USB		1	98h	98h	98h	98h	98h
	DMA		1	46h	46h	46h	46h	46h
	TA1.CCIFG0		1	62h	62h	62h	62h	62h
	TA1.CCIFG1..2		1	63h	63h	63h	63h	63h
	P1		1	50h	50h	50h	50h	50h
	USCI_A1		1	92h	92h	92h	92h	92h
	USCI_B1		1	93h	93h	93h	93h	93h
	TA1.CCIFG0		1	66h	66h	66h	66h	66h
	TA1.CCIFG1..2		1	67h	67h	67h	67h	67h
	P2		1	51h	51h	51h	51h	51h
RTC_A		1	68h	68h	68h	68h	68h	
Delimiter		1	00h	00h	00h	00h	00h	

(1) N/A = not applicable, blank = unused and reads FFh.

10 Device and Documentation Support

10.1 Getting Started and Next Steps

For an introduction to the MSP family of devices and the tools and libraries that are available to help with your development, visit the [MSP430™ ultra-low-power sensing & measurement MCUs overview](#).

10.2 Device Nomenclature

To designate the stages in the product development cycle, TI assigns prefixes to the part numbers of all MSP MCU devices. Each MSP MCU commercial family member has one of two prefixes: MSP or XMS. These prefixes represent evolutionary stages of product development from engineering prototypes (XMS) through fully qualified production devices (MSP).

XMS – Experimental device that is not necessarily representative of the final device's electrical specifications

MSP – Fully qualified production device

XMS devices are shipped against the following disclaimer:

"Developmental product is intended for internal evaluation purposes."

MSP devices have been characterized fully, and the quality and reliability of the device have been demonstrated fully. TI's standard warranty applies.

Predictions show that prototype devices (XMS) have a greater failure rate than the standard production devices. TI recommends that these devices not be used in any production system because their expected end-use failure rate still is undefined. Only qualified production devices are to be used.

TI device nomenclature also includes a suffix with the device family name. This suffix indicates the temperature range, package type, and distribution format. [Figure 10-1](#) provides a legend for reading the complete device name.

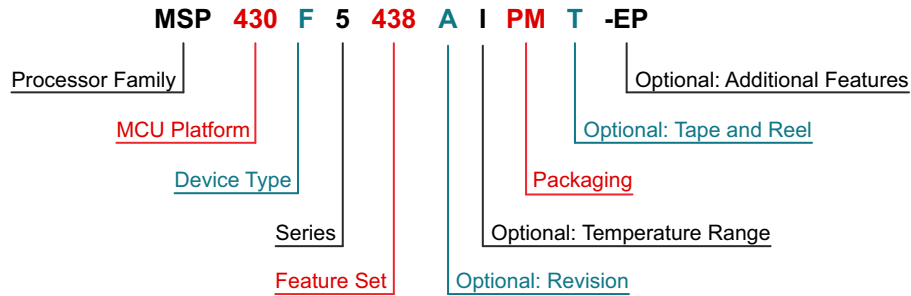

Processor Family	CC = Embedded RF Radio MSP = Mixed-Signal Processor XMS = Experimental Silicon PMS = Prototype Device		
MCU Platform	430 = MSP430 low-power microcontroller platform		
Device Type	<table border="0" style="width: 100%;"> <tr> <td style="vertical-align: top;">Memory Type C = ROM F = Flash FR = FRAM G = Flash L = No nonvolatile memory</td> <td style="vertical-align: top;">Specialized Application AFE = Analog front end BQ = Contactless power CG = ROM medical FE = Flash energy meter FG = Flash medical FW = Flash electronic flow meter</td> </tr> </table>	Memory Type C = ROM F = Flash FR = FRAM G = Flash L = No nonvolatile memory	Specialized Application AFE = Analog front end BQ = Contactless power CG = ROM medical FE = Flash energy meter FG = Flash medical FW = Flash electronic flow meter
Memory Type C = ROM F = Flash FR = FRAM G = Flash L = No nonvolatile memory	Specialized Application AFE = Analog front end BQ = Contactless power CG = ROM medical FE = Flash energy meter FG = Flash medical FW = Flash electronic flow meter		
Series	<table border="0" style="width: 100%;"> <tr> <td style="vertical-align: top;">1 = Up to 8 MHz 2 = Up to 16 MHz 3 = Legacy 4 = Up to 16 MHz with LCD driver</td> <td style="vertical-align: top;">5 = Up to 25 MHz 6 = Up to 25 MHz with LCD driver 0 = Low-voltage series</td> </tr> </table>	1 = Up to 8 MHz 2 = Up to 16 MHz 3 = Legacy 4 = Up to 16 MHz with LCD driver	5 = Up to 25 MHz 6 = Up to 25 MHz with LCD driver 0 = Low-voltage series
1 = Up to 8 MHz 2 = Up to 16 MHz 3 = Legacy 4 = Up to 16 MHz with LCD driver	5 = Up to 25 MHz 6 = Up to 25 MHz with LCD driver 0 = Low-voltage series		
Feature Set	Various levels of integration within a series		
Optional: Revision	Updated version of the base part number		
Optional: Temperature Range	S = 0°C to 50°C C = 0°C to 70°C I = -40°C to 85°C T = -40°C to 105°C		
Packaging	http://www.ti.com/packaging		
Optional: Tape and Reel	T = Small reel R = Large reel No markings = Tube or tray		
Optional: Additional Features	-EP = Enhanced product (-40°C to 105°C) -HT = Extreme temperature parts (-55°C to 150°C) -Q1 = Automotive Q100 qualified		

Figure 10-1. Device Nomenclature

10.3 Tools and Software

All MSP microcontrollers are supported by a wide variety of software and hardware development tools. Tools are available from TI and various third parties. See them all at [MSP430 ultra-low-power mcus – tools & software](#).

Table 10-1 lists the debug features of these MCUs. See the [Code Composer Studio IDE for MSP430 MCUs user's guide](#) for details on the available features.

Table 10-1. Hardware Debug Features

MSP430 ARCHITECTURE	4-WIRE JTAG	2-WIRE JTAG	BREAK-POINTS (N)	RANGE BREAK-POINTS	CLOCK CONTROL	STATE SEQUENCER	TRACE BUFFER	LPMx.5 DEBUGGING SUPPORT
MSP430Xv2	Yes	Yes	8	Yes	Yes	Yes	Yes	No

Design Kits and Evaluation Modules

[MSP430F5529 USB LaunchPad Development Kit](#)

Develop low-power PC-connected applications with integrated full-speed USB 2.0 (HID, MSC, CDC). The MSP-EXP430F5529LP LaunchPad kit is an inexpensive, simple microcontroller development kit for the MSP430F5529 USB microcontroller. It's an easy way to start developing on the MSP430 MCU, with an on-board emulation for programming and debugging, as well as buttons and LEDs for simple user interface.

[MSP430F5529 USB Experimenter's Board](#)

The MSP430F5529 Experimenter Board (MSP-EXP430F5529) is a development platform for the MSP430F5529 device, from the latest generation of MSP430 devices with integrated USB. The board is compatible with many TI low-power RF wireless evaluation modules such as the CC2520EMK. The Experimenter Board helps designers quickly learn and develop using the new F55xx MCUs, which provide the industry's lowest active power consumption, integrated USB, and more memory and leading integration for applications such as energy harvesting, wireless sensing and automatic metering infrastructure (AMI).

[64-pin target development board and MSP-FET programmer bundle for MSP430F5x MCUs](#)

The MSP-FET430U64USB is a powerful flash emulation tool that allows you to quickly begin application development on the MSP430 MCU. It includes USB debugging interface used to program and debug the MSP430 in-system through the JTAG interface or the pin saving Spy Bi-Wire (2-wire JTAG) protocol. The flash memory can be erased and programmed in seconds with only a few keystrokes, and because the MSP430 flash is ultra-low power, no external power supply is required.

[80-pin target development board and MSP-FET programmer bundle for MSP430F5x MCUs](#)

The MSP-FET is a powerful flash emulation tool to quickly begin application development on the MSP430 MCU. It includes USB debugging interface used to program and debug the MSP430 in-system through the JTAG interface or the pin-saving Spy-Bi-Wire (2-wire JTAG) protocol. The flash memory can be erased and programmed in seconds with only a few keystrokes, and because the MSP430 flash is ultra-low power, no external power supply is required. The debugging tool interfaces the MSP430 to the included integrated software environment and includes code to start your design immediately.

Software

[MSP430Ware™ Software](#)

MSP430Ware software is a collection of code examples, data sheets, and other design resources for all MSP430 devices delivered in a convenient package. In addition to providing a complete collection of existing MSP430 design resources, MSP430Ware software also includes a high-level API called MSP Driver Library. This library makes it easy to program MSP430 hardware. MSP430Ware software is available as a component of Code Composer Studio™ IDE or as a stand-alone package.

[MSP430F552x Code Examples](#)

C code examples are available for every MSP device that configures each of the integrated peripherals for various application needs.

[MSP Driver Library](#)

Driver Library's abstracted API keeps you above the bits and bytes of the MSP430 hardware by providing easy-to-use function calls. Thorough documentation is delivered through a helpful API Guide, which includes details on each function call and the recognized parameters. Developers can use Driver Library functions to write complete projects with minimal overhead.

[MSP EnergyTrace™ Technology](#)

EnergyTrace technology for MSP430 microcontrollers is an energy-based code analysis tool that measures and displays the application's energy profile and helps to optimize it for ultra-low-power consumption.

[ULP \(Ultra-Low Power\) Advisor](#)

ULP Advisor™ software is a tool for guiding developers to write more efficient code to fully utilize the unique ultra-low power features of MSP and MSP432 microcontrollers. Aimed at both experienced and new microcontroller developers, ULP Advisor checks your code against a thorough ULP checklist to squeeze every last nano amp out of your application. At build time, ULP Advisor will provide notifications and remarks to highlight areas of your code that can be further optimized for lower power.

[IEC60730 Software Package](#)

The IEC60730 MSP430 software package was developed to be useful in assisting customers in complying with IEC 60730-1:2010 (Automatic Electrical Controls for Household and Similar Use – Part 1: General Requirements) for up to Class B products, which includes home appliances, arc detectors, power converters, power tools, e-bikes, and many others. The IEC60730 MSP430 software package can be embedded in customer applications running on MSP430s to help simplify the customer's certification efforts of functional safety-compliant consumer devices to IEC 60730-1:2010 Class B.

[Fixed Point Math Library for MSP](#)

The MSP IQmath and Qmath Libraries are a collection of highly optimized and high-precision mathematical functions for C programmers to seamlessly port a floating-point algorithm into fixed-point code on MSP430 and MSP432 devices. These routines are typically used in computationally intensive real-time applications where optimal execution speed, high accuracy, and ultra-low energy are critical. By using the IQmath and Qmath libraries, it is possible to achieve execution speeds considerably faster and energy consumption considerably lower than equivalent code written using floating-point math.

[Floating Point Math Library for MSP430](#)

Continuing to innovate in the low power and low cost microcontroller space, TI brings you MSPMATHLIB. Leveraging the intelligent peripherals of our devices, this floating point math library of scalar functions brings you up to 26x better performance. Mathlib is easy to integrate into your designs. This library is free and is integrated in both Code Composer Studio and IAR IDEs. Read the user's guide for an in depth look at the math library and relevant benchmarks.

Development Tools

Code Composer Studio™ Integrated Development Environment for MSP Microcontrollers

Code Composer Studio integrated development environment (IDE) supports all MSP microcontroller devices. Code Composer Studio IDE comprises a suite of embedded software utilities used to develop and debug embedded applications. It includes an optimizing C/C++ compiler, source code editor, project build environment, debugger, profiler, and many other features.

Code Composer Studio IDE combines the advantages of the Eclipse software framework with advanced embedded debug capabilities from TI resulting in a compelling feature-rich development environment for embedded developers. When using CCS with an MSP430 MCU, a unique and powerful set of plugins and embedded software utilities are made available to fully leverage the MSP430 microcontroller.

Command-Line Programmer

MSP Flasher is an open-source shell-based interface for programming MSP microcontrollers through a FET programmer or eZ430 using JTAG or Spy-Bi-Wire (SBW) communication. MSP Flasher can download binary files (.txt or .hex) files directly to the MSP microcontroller without an IDE.

MSP MCU Programmer and Debugger

The MSP-FET is a powerful emulation development tool – often called a debug probe – that allows users to quickly begin application development on MSP low-power microcontrollers (MCU). Creating MCU software usually requires downloading the resulting binary program to the MSP device for validation and debugging. The MSP-FET provides a debug communication pathway between a host computer and the target MSP. Furthermore, the MSP-FET also provides a Backchannel UART connection between the computer's USB interface and the MSP UART. This affords the MSP programmer a convenient method for communicating serially between the MSP and a terminal running on the computer. It also supports loading programs (often called firmware) to the MSP target using the BSL (bootloader) through the UART and I²C communication protocols.

MSP-GANG Production Programmer

The MSP Gang Programmer is a device programmer that can program up to eight identical MSP430 or MSP432 flash or FRAM devices at the same time. The MSP Gang Programmer connects to a host PC using a standard RS-232 or USB connection and provides flexible programming options that allow the user to fully customize the process. The MSP Gang Programmer is provided with an expansion board, called the Gang Splitter, that implements the interconnections between the MSP Gang Programmer and multiple target devices. Eight cables are provided that connect the expansion board to eight target devices (through JTAG or Spy-Bi-Wire connectors). The programming can be done with a PC or as a stand-alone device. A PC-side graphical user interface is also available and is DLL-based.

10.4 Documentation Support

The following documents describe the MSP430F552x and MSP430F551x devices. Copies of these documents are available on the Internet at www.ti.com.

Receiving Notification of Document Updates

To receive notification of documentation updates—including silicon errata—go to the product folder for your device on ti.com (for links to the product folders, see [Section 10.5](#)). In the upper right corner, click the "Alert me" button. This registers you to receive a weekly digest of product information that has changed (if any). For change details, check the revision history of any revised document.

Errata

[MSP430F5529 Device Erratasheet](#)

Describes the known exceptions to the functional specifications.

[MSP430F5528 Device Erratasheet](#)

Describes the known exceptions to the functional specifications.

[MSP430F5527 Device Erratasheet](#)

Describes the known exceptions to the functional specifications.

[MSP430F5526 Device Erratasheet](#)

Describes the known exceptions to the functional specifications.

[MSP430F5525 Device Erratasheet](#)

Describes the known exceptions to the functional specifications.

[MSP430F5524 Device Erratasheet](#)

Describes the known exceptions to the functional specifications.

[MSP430F5522 Device Erratasheet](#)

Describes the known exceptions to the functional specifications.

[MSP430F5521 Device Erratasheet](#)

Describes the known exceptions to the functional specifications.

[MSP430F5519 Device Erratasheet](#)

Describes the known exceptions to the functional specifications.

[MSP430F5517 Device Erratasheet](#)

Describes the known exceptions to the functional specifications.

[MSP430F5515 Device Erratasheet](#)

Describes the known exceptions to the functional specifications.

[MSP430F5514 Device Erratasheet](#)

Describes the known exceptions to the functional specifications.

[MSP430F5513 Device Erratasheet](#)

Describes the known exceptions to the functional specifications.

User's Guides

[MSP430x5xx and MSP430x6xx Family User's Guide](#)

Detailed information on the modules and peripherals available in this device family.

[MSP430 Flash Device Bootloader \(BSL\) User's Guide](#)

The MSP430 bootloader (BSL) lets users communicate with embedded memory in the MSP430 microcontroller during the prototyping phase, final production, and in service. Both the programmable memory (flash memory) and the data memory (RAM) can be modified as required. Do not confuse the bootloader with the bootstrap loader programs found in some digital signal processors (DSPs) that automatically load program code (and data) from external memory to the internal memory of the DSP.

MSP430 Programming With the JTAG Interface

This document describes the functions that are required to erase, program, and verify the memory module of the MSP430 flash-based and FRAM-based microcontroller families using the JTAG communication port. In addition, it describes how to program the JTAG access security fuse that is available on all MSP430 devices. This document describes device access using both the standard 4-wire JTAG interface and the 2-wire JTAG interface, which is also referred to as Spy-Bi-Wire (SBW).

MSP430 Hardware Tools User's Guide

This manual describes the hardware of the TI MSP-FET430 Flash Emulation Tool (FET). The FET is the program development tool for the MSP430 ultra-low-power microcontroller. Both available interface types, the parallel port interface and the USB interface, are described.

Application Reports

MSP430 32-kHz Crystal Oscillators

Selection of the right crystal, correct load circuit, and proper board layout are important for a stable crystal oscillator. This application report summarizes crystal oscillator function and explains the parameters to select the correct crystal for MSP430 ultra-low-power operation. In addition, hints and examples for correct board layout are given. The document also contains detailed information on the possible oscillator tests to ensure stable oscillator operation in mass production.

MSP430 System-Level ESD Considerations

System-level ESD has become increasingly demanding with silicon technology scaling towards lower voltages and the need for designing cost-effective and ultra-low-power components. This application report addresses different ESD topics to help board designers and OEMs understand and design robust system-level designs. A few real-world system-level ESD protection design examples and their results are also discussed.

10.5 Related Links

Table 10-2 lists quick access links. Categories include technical documents, support and community resources, tools and software, and quick access to sample or buy.

Table 10-2. Related Links

PARTS	PRODUCT FOLDER	ORDER NOW	TECHNICAL DOCUMENTS	TOOLS & SOFTWARE	SUPPORT & COMMUNITY
MSP430F5529	Click here	Click here	Click here	Click here	Click here
MSP430F5528	Click here	Click here	Click here	Click here	Click here
MSP430F5527	Click here	Click here	Click here	Click here	Click here
MSP430F5526	Click here	Click here	Click here	Click here	Click here
MSP430F5525	Click here	Click here	Click here	Click here	Click here
MSP430F5524	Click here	Click here	Click here	Click here	Click here
MSP430F5522	Click here	Click here	Click here	Click here	Click here
MSP430F5521	Click here	Click here	Click here	Click here	Click here
MSP430F5519	Click here	Click here	Click here	Click here	Click here
MSP430F5517	Click here	Click here	Click here	Click here	Click here
MSP430F5515	Click here	Click here	Click here	Click here	Click here
MSP430F5514	Click here	Click here	Click here	Click here	Click here
MSP430F5513	Click here	Click here	Click here	Click here	Click here

10.6 Support Resources

TI E2E™ [support forums](#) are an engineer's go-to source for fast, verified answers and design help — straight from the experts. Search existing answers or ask your own question to get the quick design help you need.

Linked content is provided "AS IS" by the respective contributors. They do not constitute TI specifications and do not necessarily reflect TI's views; see TI's [Terms of Use](#).

10.7 Trademarks

LaunchPad™, MSP430Ware™, MSP430™, Code Composer Studio™, TI E2E™, MicroStar Junior™, EnergyTrace™, ULP Advisor™, are trademarks of Texas Instruments.

All other trademarks are the property of their respective owners.

10.8 Electrostatic Discharge Caution



This integrated circuit can be damaged by ESD. Texas Instruments recommends that all integrated circuits be handled with appropriate precautions. Failure to observe proper handling and installation procedures can cause damage.

ESD damage can range from subtle performance degradation to complete device failure. Precision integrated circuits may be more susceptible to damage because very small parametric changes could cause the device not to meet its published specifications.

10.9 Export Control Notice

Recipient agrees to not knowingly export or re-export, directly or indirectly, any product or technical data (as defined by the U.S., EU, and other Export Administration Regulations) including software, or any controlled product restricted by other applicable national regulations, received from disclosing party under nondisclosure obligations (if any), or any direct product of such technology, to any destination to which such export or re-export is restricted or prohibited by U.S. or other applicable laws, without obtaining prior authorization from U.S. Department of Commerce and other competent Government authorities to the extent required by those laws.

10.10 Glossary

TI Glossary This glossary lists and explains terms, acronyms, and definitions.

11 Mechanical, Packaging, and Orderable Information

The following pages include mechanical, packaging, and orderable information. This information is the most current data available for the designated devices. This data is subject to change without notice and revision of this document. For browser-based versions of this data sheet, refer to the left-hand navigation.

PACKAGING INFORMATION

Orderable Device	Status (1)	Package Type	Package Drawing	Pins	Package Qty	Eco Plan (2)	Lead finish/ Ball material (6)	MSL Peak Temp (3)	Op Temp (°C)	Device Marking (4/5)	Samples
MSP430F5513IRGCR	ACTIVE	VQFN	RGC	64	2000	RoHS & Green	NIPDAU NIPDAUAG	Level-3-260C-168 HR	-40 to 85	M430F5513	Samples
MSP430F5514IRGCR	ACTIVE	VQFN	RGC	64	2000	RoHS & Green	NIPDAU NIPDAUAG	Level-3-260C-168 HR	-40 to 85	M430F5514	Samples
MSP430F5514IRGCT	ACTIVE	VQFN	RGC	64	250	RoHS & Green	NIPDAU NIPDAUAG	Level-3-260C-168 HR	-40 to 85	M430F5514	Samples
MSP430F5515IPN	ACTIVE	LQFP	PN	80	119	RoHS & Green	NIPDAU	Level-3-260C-168 HR	-40 to 85	M430F5515	Samples
MSP430F5515IPNR	ACTIVE	LQFP	PN	80	1000	RoHS & Green	NIPDAU	Level-3-260C-168 HR	-40 to 85	M430F5515	Samples
MSP430F5517IPN	ACTIVE	LQFP	PN	80	119	RoHS & Green	NIPDAU	Level-3-260C-168 HR	-40 to 85	M430F5517	Samples
MSP430F5517IPNR	ACTIVE	LQFP	PN	80	1000	RoHS & Green	NIPDAU	Level-3-260C-168 HR	-40 to 85	M430F5517	Samples
MSP430F5519IPN	ACTIVE	LQFP	PN	80	119	RoHS & Green	NIPDAU	Level-3-260C-168 HR	-40 to 85	M430F5519	Samples
MSP430F5519IPNR	ACTIVE	LQFP	PN	80	1000	RoHS & Green	NIPDAU	Level-3-260C-168 HR	-40 to 85	M430F5519	Samples
MSP430F5521IPN	ACTIVE	LQFP	PN	80	119	RoHS & Green	NIPDAU	Level-3-260C-168 HR	-40 to 85	M430F5521	Samples
MSP430F5521IPNR	ACTIVE	LQFP	PN	80	1000	RoHS & Green	NIPDAU	Level-3-260C-168 HR	-40 to 85	M430F5521	Samples
MSP430F5522IRGCR	ACTIVE	VQFN	RGC	64	2000	RoHS & Green	NIPDAU NIPDAUAG	Level-3-260C-168 HR	-40 to 85	M430F5522	Samples
MSP430F5522IRGCT	ACTIVE	VQFN	RGC	64	250	RoHS & Green	NIPDAU NIPDAUAG	Level-3-260C-168 HR	-40 to 85	M430F5522	Samples
MSP430F5522IZXH	ACTIVE	NFBGA	ZXH	80	576	RoHS & Green	SNAGCU	Level-3-260C-168 HR	-40 to 85	F5522	Samples
MSP430F5522IZXHR	ACTIVE	NFBGA	ZXH	80	2500	RoHS & Green	SNAGCU	Level-3-260C-168 HR	-40 to 85	F5522	Samples
MSP430F5524IRGCR	ACTIVE	VQFN	RGC	64	2000	RoHS & Green	NIPDAU NIPDAUAG	Level-3-260C-168 HR	-40 to 85	M430F5524	Samples
MSP430F5524IRGCT	ACTIVE	VQFN	RGC	64	250	RoHS & Green	NIPDAU NIPDAUAG	Level-3-260C-168 HR	-40 to 85	M430F5524	Samples
MSP430F5524IZXH	ACTIVE	NFBGA	ZXH	80	576	RoHS & Green	SNAGCU	Level-3-260C-168 HR	-40 to 85	F5524	Samples
MSP430F5524IZXHR	ACTIVE	NFBGA	ZXH	80	2500	RoHS & Green	SNAGCU	Level-3-260C-168 HR	-40 to 85	F5524	Samples
MSP430F5525IPN	ACTIVE	LQFP	PN	80	119	RoHS & Green	NIPDAU	Level-3-260C-168 HR	-40 to 85	M430F5525	Samples

Orderable Device	Status (1)	Package Type	Package Drawing	Pins	Package Qty	Eco Plan (2)	Lead finish/ Ball material (6)	MSL Peak Temp (3)	Op Temp (°C)	Device Marking (4/5)	Samples
MSP430F5525IPNR	ACTIVE	LQFP	PN	80	1000	RoHS & Green	NIPDAU	Level-3-260C-168 HR	-40 to 85	M430F5525	Samples
MSP430F5526IRGCR	ACTIVE	VQFN	RGC	64	2000	RoHS & Green	NIPDAU NIPDAUAG	Level-3-260C-168 HR	-40 to 85	M430F5526	Samples
MSP430F5526IRGCT	ACTIVE	VQFN	RGC	64	250	RoHS & Green	NIPDAU NIPDAUAG	Level-3-260C-168 HR	-40 to 85	M430F5526	Samples
MSP430F5526IZXH	ACTIVE	NFBGA	ZXH	80	576	RoHS & Green	SNAGCU	Level-3-260C-168 HR	-40 to 85	F5526	Samples
MSP430F5526IZXHR	ACTIVE	NFBGA	ZXH	80	2500	RoHS & Green	SNAGCU	Level-3-260C-168 HR	-40 to 85	F5526	Samples
MSP430F5527IPN	ACTIVE	LQFP	PN	80	119	RoHS & Green	NIPDAU	Level-3-260C-168 HR	-40 to 85	M430F5527	Samples
MSP430F5527IPNR	ACTIVE	LQFP	PN	80	1000	RoHS & Green	NIPDAU	Level-3-260C-168 HR	-40 to 85	M430F5527	Samples
MSP430F5528IRGCR	ACTIVE	VQFN	RGC	64	2000	RoHS & Green	NIPDAU NIPDAUAG	Level-3-260C-168 HR	-40 to 85	M430F5528	Samples
MSP430F5528IRGCT	ACTIVE	VQFN	RGC	64	250	RoHS & Green	NIPDAU NIPDAUAG	Level-3-260C-168 HR	-40 to 85	M430F5528	Samples
MSP430F5528YFFR	ACTIVE	DSBGA	YFF	64	2500	RoHS & Green	SNAGCU	Level-1-260C-UNLIM	-40 to 85	M430F5528	Samples
MSP430F5528IZXH	ACTIVE	NFBGA	ZXH	80	576	RoHS & Green	SNAGCU	Level-3-260C-168 HR	-40 to 85	F5528	Samples
MSP430F5528IZXHR	ACTIVE	NFBGA	ZXH	80	2500	RoHS & Green	SNAGCU	Level-3-260C-168 HR	-40 to 85	F5528	Samples
MSP430F5529IPN	ACTIVE	LQFP	PN	80	119	RoHS & Green	NIPDAU	Level-3-260C-168 HR	-40 to 85	M430F5529	Samples
MSP430F5529IPNR	ACTIVE	LQFP	PN	80	1000	RoHS & Green	NIPDAU	Level-3-260C-168 HR	-40 to 85	M430F5529	Samples

(1) The marketing status values are defined as follows:

ACTIVE: Product device recommended for new designs.

LIFEBUY: TI has announced that the device will be discontinued, and a lifetime-buy period is in effect.

NRND: Not recommended for new designs. Device is in production to support existing customers, but TI does not recommend using this part in a new design.

PREVIEW: Device has been announced but is not in production. Samples may or may not be available.

OBSELETE: TI has discontinued the production of the device.

(2) **RoHS:** TI defines "RoHS" to mean semiconductor products that are compliant with the current EU RoHS requirements for all 10 RoHS substances, including the requirement that RoHS substance do not exceed 0.1% by weight in homogeneous materials. Where designed to be soldered at high temperatures, "RoHS" products are suitable for use in specified lead-free processes. TI may reference these types of products as "Pb-Free".

RoHS Exempt: TI defines "RoHS Exempt" to mean products that contain lead but are compliant with EU RoHS pursuant to a specific EU RoHS exemption.

Green: TI defines "Green" to mean the content of Chlorine (Cl) and Bromine (Br) based flame retardants meet JS709B low halogen requirements of <=1000ppm threshold. Antimony trioxide based flame retardants must also meet the <=1000ppm threshold requirement.

- (3) MSL, Peak Temp. - The Moisture Sensitivity Level rating according to the JEDEC industry standard classifications, and peak solder temperature.
- (4) There may be additional marking, which relates to the logo, the lot trace code information, or the environmental category on the device.
- (5) Multiple Device Markings will be inside parentheses. Only one Device Marking contained in parentheses and separated by a "~" will appear on a device. If a line is indented then it is a continuation of the previous line and the two combined represent the entire Device Marking for that device.
- (6) Lead finish/Ball material - Orderable Devices may have multiple material finish options. Finish options are separated by a vertical ruled line. Lead finish/Ball material values may wrap to two lines if the finish value exceeds the maximum column width.

Important Information and Disclaimer:The information provided on this page represents TI's knowledge and belief as of the date that it is provided. TI bases its knowledge and belief on information provided by third parties, and makes no representation or warranty as to the accuracy of such information. Efforts are underway to better integrate information from third parties. TI has taken and continues to take reasonable steps to provide representative and accurate information but may not have conducted destructive testing or chemical analysis on incoming materials and chemicals. TI and TI suppliers consider certain information to be proprietary, and thus CAS numbers and other limited information may not be available for release.

In no event shall TI's liability arising out of such information exceed the total purchase price of the TI part(s) at issue in this document sold by TI to Customer on an annual basis.

TAPE AND REEL INFORMATION

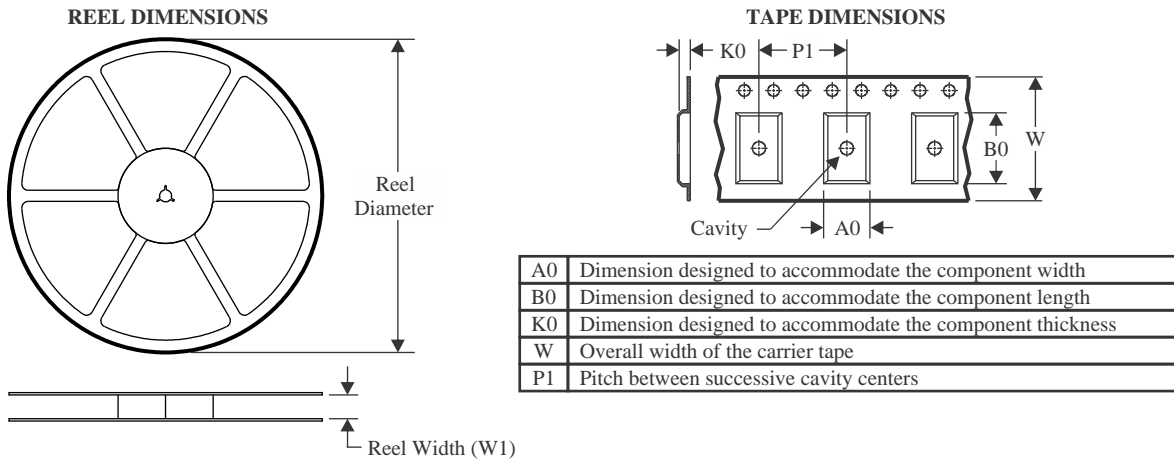

QUADRANT ASSIGNMENTS FOR PIN 1 ORIENTATION IN TAPE

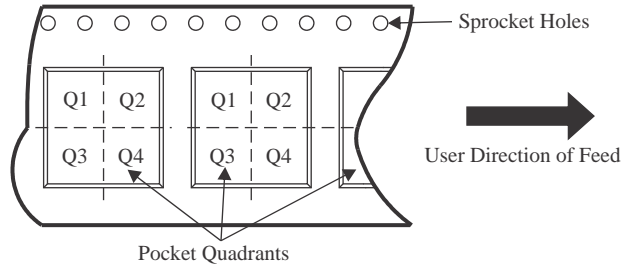

*All dimensions are nominal

Device	Package Type	Package Drawing	Pins	SPQ	Reel Diameter (mm)	Reel Width W1 (mm)	A0 (mm)	B0 (mm)	K0 (mm)	P1 (mm)	W (mm)	Pin1 Quadrant
MSP430F5513IRGCR	VQFN	RGC	64	2000	330.0	16.4	9.3	9.3	1.1	12.0	16.0	Q2
MSP430F5513IRGCR	VQFN	RGC	64	2000	330.0	16.4	9.3	9.3	1.5	12.0	16.0	Q2
MSP430F5514IRGCR	VQFN	RGC	64	2000	330.0	16.4	9.3	9.3	1.5	12.0	16.0	Q2
MSP430F5514IRGCT	VQFN	RGC	64	250	180.0	16.4	9.3	9.3	1.5	12.0	16.0	Q2
MSP430F5514IRGCT	VQFN	RGC	64	250	180.0	16.4	9.3	9.3	1.1	12.0	16.0	Q2
MSP430F5515IPNR	LQFP	PN	80	1000	330.0	24.4	15.0	15.0	2.1	20.0	24.0	Q2
MSP430F5517IPNR	LQFP	PN	80	1000	330.0	24.4	15.0	15.0	2.1	20.0	24.0	Q2
MSP430F5519IPNR	LQFP	PN	80	1000	330.0	24.4	15.0	15.0	2.1	20.0	24.0	Q2
MSP430F5521IPNR	LQFP	PN	80	1000	330.0	24.4	15.0	15.0	2.1	20.0	24.0	Q2
MSP430F5522IRGCR	VQFN	RGC	64	2000	330.0	16.4	9.3	9.3	1.1	12.0	16.0	Q2
MSP430F5522IRGCR	VQFN	RGC	64	2000	330.0	16.4	9.3	9.3	1.5	12.0	16.0	Q2
MSP430F5522IRGCT	VQFN	RGC	64	250	180.0	16.4	9.3	9.3	1.1	12.0	16.0	Q2
MSP430F5522IRGCT	VQFN	RGC	64	250	180.0	16.4	9.3	9.3	1.5	12.0	16.0	Q2
MSP430F5522IZXHR	NFBGA	ZXH	80	2500	330.0	12.4	5.3	5.3	1.5	8.0	12.0	Q1
MSP430F5524IRGCR	VQFN	RGC	64	2000	330.0	16.4	9.3	9.3	1.5	12.0	16.0	Q2
MSP430F5524IRGCR	VQFN	RGC	64	2000	330.0	16.4	9.3	9.3	1.1	12.0	16.0	Q2

Device	Package Type	Package Drawing	Pins	SPQ	Reel Diameter (mm)	Reel Width W1 (mm)	A0 (mm)	B0 (mm)	K0 (mm)	P1 (mm)	W (mm)	Pin1 Quadrant
MSP430F5524IRGCT	VQFN	RGC	64	250	180.0	16.4	9.3	9.3	1.1	12.0	16.0	Q2
MSP430F5524IRGCT	VQFN	RGC	64	250	180.0	16.4	9.3	9.3	1.5	12.0	16.0	Q2
MSP430F5524IZXHR	NFBGA	ZXH	80	2500	330.0	12.4	5.3	5.3	1.5	8.0	12.0	Q1
MSP430F5525IPNR	LQFP	PN	80	1000	330.0	24.4	15.0	15.0	2.1	20.0	24.0	Q2
MSP430F5526IRGCR	VQFN	RGC	64	2000	330.0	16.4	9.3	9.3	1.5	12.0	16.0	Q2
MSP430F5526IRGCT	VQFN	RGC	64	250	180.0	16.4	9.3	9.3	1.1	12.0	16.0	Q2
MSP430F5526IRGCT	VQFN	RGC	64	250	180.0	16.4	9.3	9.3	1.5	12.0	16.0	Q2
MSP430F5527IPNR	LQFP	PN	80	1000	330.0	24.4	15.0	15.0	2.1	20.0	24.0	Q2
MSP430F5528IRGCR	VQFN	RGC	64	2000	330.0	16.4	9.3	9.3	1.5	12.0	16.0	Q2
MSP430F5528IRGCT	VQFN	RGC	64	250	180.0	16.4	9.3	9.3	1.5	12.0	16.0	Q2
MSP430F5528IYFFR	DSBGA	YFF	64	2500	330.0	12.4	3.86	3.86	0.69	8.0	12.0	Q2
MSP430F5529IPNR	LQFP	PN	80	1000	330.0	24.4	15.0	15.0	2.1	20.0	24.0	Q2

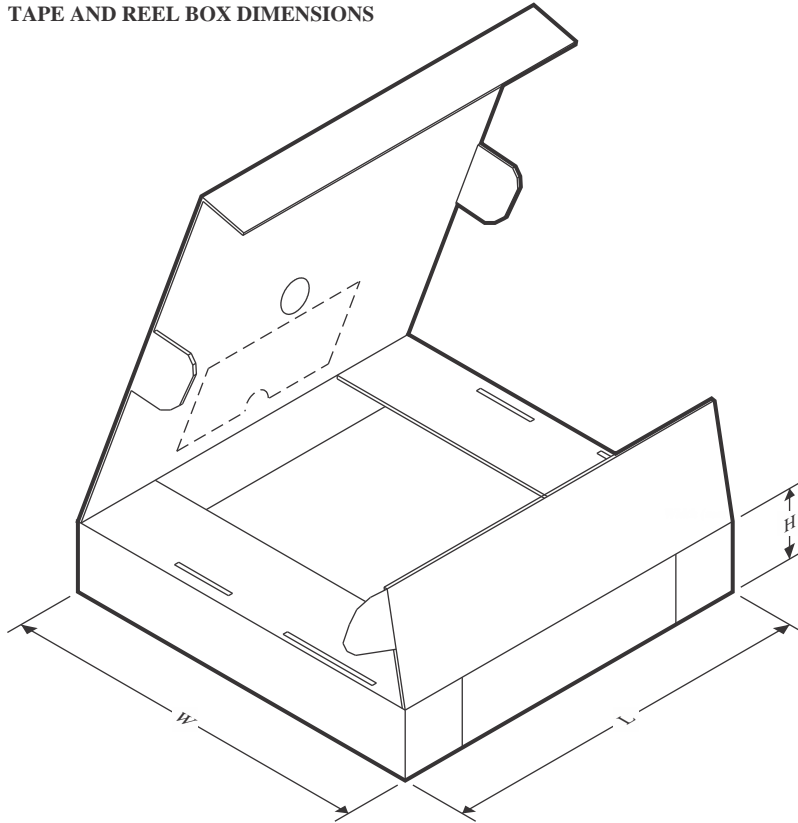
TAPE AND REEL BOX DIMENSIONS

*All dimensions are nominal

Device	Package Type	Package Drawing	Pins	SPQ	Length (mm)	Width (mm)	Height (mm)
MSP430F5513IRGCR	VQFN	RGC	64	2000	367.0	367.0	38.0
MSP430F5513IRGCR	VQFN	RGC	64	2000	356.0	356.0	35.0
MSP430F5514IRGCR	VQFN	RGC	64	2000	367.0	367.0	38.0
MSP430F5514IRGCT	VQFN	RGC	64	250	210.0	185.0	35.0
MSP430F5514IRGCT	VQFN	RGC	64	250	213.0	191.0	35.0
MSP430F5515IPNR	LQFP	PN	80	1000	350.0	350.0	43.0
MSP430F5517IPNR	LQFP	PN	80	1000	350.0	350.0	43.0
MSP430F5519IPNR	LQFP	PN	80	1000	350.0	350.0	43.0
MSP430F5521IPNR	LQFP	PN	80	1000	350.0	350.0	43.0
MSP430F5522IRGCR	VQFN	RGC	64	2000	367.0	367.0	38.0
MSP430F5522IRGCR	VQFN	RGC	64	2000	367.0	367.0	38.0
MSP430F5522IRGCT	VQFN	RGC	64	250	213.0	191.0	35.0
MSP430F5522IRGCT	VQFN	RGC	64	250	210.0	185.0	35.0
MSP430F5522IZXHR	NFBGA	ZXH	80	2500	350.0	350.0	43.0
MSP430F5524IRGCR	VQFN	RGC	64	2000	367.0	367.0	38.0
MSP430F5524IRGCR	VQFN	RGC	64	2000	367.0	367.0	38.0
MSP430F5524IRGCT	VQFN	RGC	64	250	213.0	191.0	35.0
MSP430F5524IRGCT	VQFN	RGC	64	250	210.0	185.0	35.0

Device	Package Type	Package Drawing	Pins	SPQ	Length (mm)	Width (mm)	Height (mm)
MSP430F5524IZXHR	NFBGA	ZXH	80	2500	350.0	350.0	43.0
MSP430F5525IPNR	LQFP	PN	80	1000	350.0	350.0	43.0
MSP430F5526IRGCR	VQFN	RGC	64	2000	356.0	356.0	35.0
MSP430F5526IRGCT	VQFN	RGC	64	250	213.0	191.0	35.0
MSP430F5526IRGCT	VQFN	RGC	64	250	210.0	185.0	35.0
MSP430F5527IPNR	LQFP	PN	80	1000	350.0	350.0	43.0
MSP430F5528IRGCR	VQFN	RGC	64	2000	367.0	367.0	38.0
MSP430F5528IRGCT	VQFN	RGC	64	250	210.0	185.0	35.0
MSP430F5528IYFFR	DSBGA	YFF	64	2500	335.0	335.0	25.0
MSP430F5529IPNR	LQFP	PN	80	1000	350.0	350.0	43.0

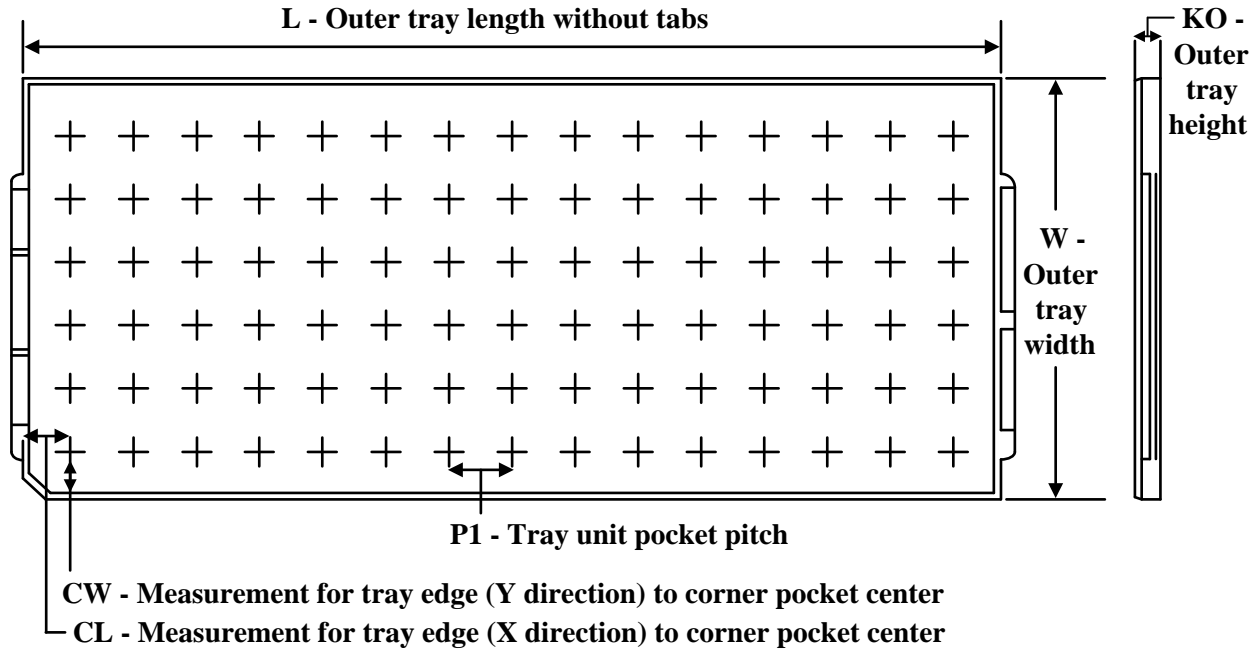
TRAY

Chamfer on Tray corner indicates Pin 1 orientation of packed units.

*All dimensions are nominal

Device	Package Name	Package Type	Pins	SPQ	Unit array matrix	Max temperature (°C)	L (mm)	W (mm)	K0 (µm)	P1 (mm)	CL (mm)	CW (mm)
MSP430F5515IPN	PN	LQFP	80	119	7 x 17	150	315	135.9	7620	17.9	14.3	13.95
MSP430F5517IPN	PN	LQFP	80	119	7 x 17	150	315	135.9	7620	17.9	14.3	13.95
MSP430F5519IPN	PN	LQFP	80	119	7 x 17	150	315	135.9	7620	17.9	14.3	13.95
MSP430F5521IPN	PN	LQFP	80	119	7 x 17	150	315	135.9	7620	17.9	14.3	13.95
MSP430F5522IZXH	ZXH	NFBGA	80	576	16 x 36	150	315	135.9	7620	8.5	8.75	8.7
MSP430F5522IZXHR	ZXH	NFBGA	80	2500	16 x 36	150	315	135.9	7620	8.5	8.75	8.7
MSP430F5524IZXH	ZXH	NFBGA	80	576	16 x 36	150	315	135.9	7620	8.5	8.75	8.7
MSP430F5524IZXHR	ZXH	NFBGA	80	2500	16 x 36	150	315	135.9	7620	8.5	8.75	8.7
MSP430F5525IPN	PN	LQFP	80	119	7 x 17	150	315	135.9	7620	17.9	14.3	13.95
MSP430F5526IZXH	ZXH	NFBGA	80	576	16 x 36	150	315	135.9	7620	8.5	8.75	8.7
MSP430F5526IZXHR	ZXH	NFBGA	80	2500	16 x 36	150	315	135.9	7620	8.5	8.75	8.7
MSP430F5527IPN	PN	LQFP	80	119	7 x 17	150	315	135.9	7620	17.9	14.3	13.95
MSP430F5528IZXH	ZXH	NFBGA	80	576	16 x 36	150	315	135.9	7620	8.5	8.75	8.7
MSP430F5528IZXHR	ZXH	NFBGA	80	576	16 x 36	150	315	135.9	7620	8.5	8.75	8.7

Device	Package Name	Package Type	Pins	SPQ	Unit array matrix	Max temperature (°C)	L (mm)	W (mm)	K0 (µm)	P1 (mm)	CL (mm)	CW (mm)
MSP430F5528IZXHR	ZXH	NFBGA	80	2500	16 x 36	150	315	135.9	7620	8.5	8.75	8.7
MSP430F5529IPN	PN	LQFP	80	119	7 x 17	150	315	135.9	7620	17.9	14.3	13.95

GENERIC PACKAGE VIEW

RGC 64

VQFN - 1 mm max height

9 x 9, 0.5 mm pitch

PLASTIC QUAD FLATPACK - NO LEAD

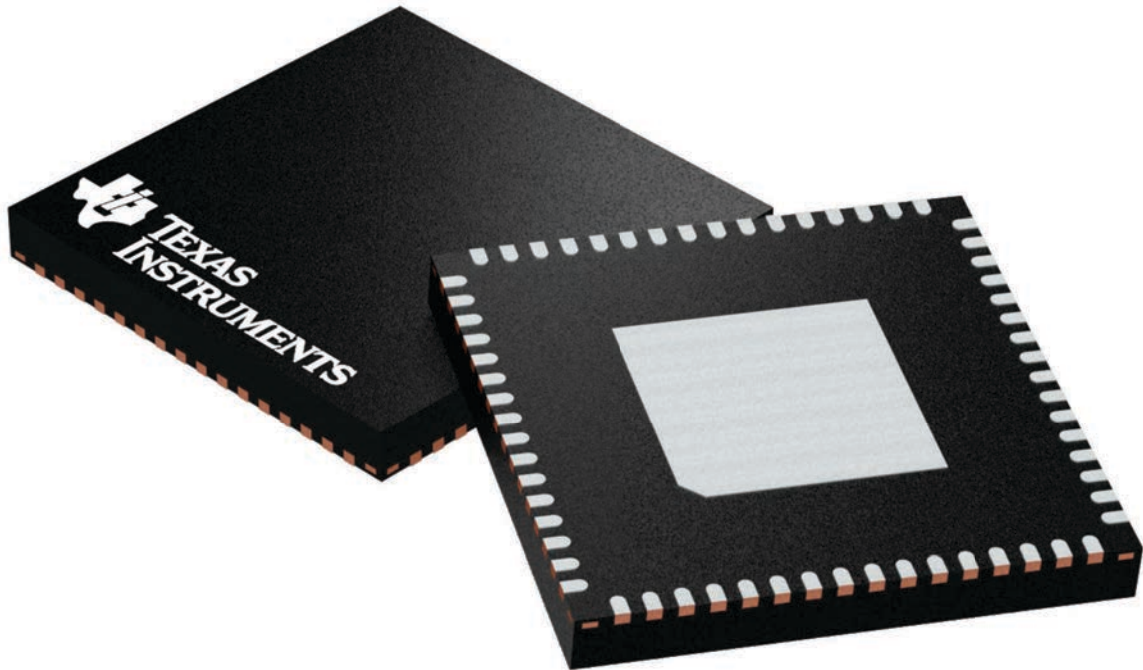

Images above are just a representation of the package family, actual package may vary.
Refer to the product data sheet for package details.

4224597/A

RGC0064B

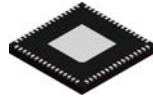

PACKAGE OUTLINE

VQFN - 1 mm max height

PLASTIC QUAD FLATPACK - NO LEAD

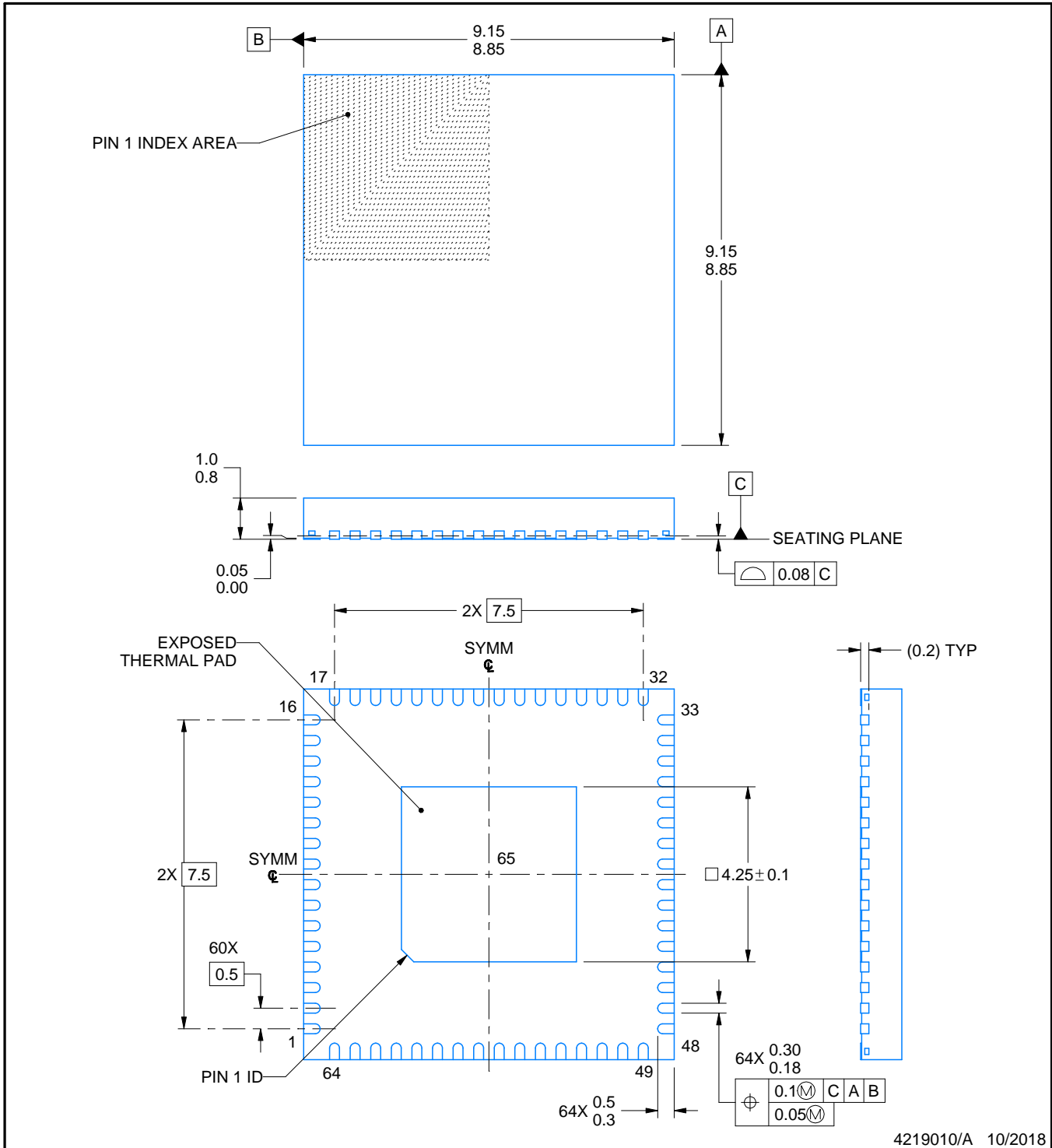

NOTES:

1. All linear dimensions are in millimeters. Any dimensions in parenthesis are for reference only. Dimensioning and tolerancing per ASME Y14.5M.
2. This drawing is subject to change without notice.
3. The package thermal pad must be soldered to the printed circuit board for thermal and mechanical performance.

EXAMPLE BOARD LAYOUT

RGC0064B

VQFN - 1 mm max height

PLASTIC QUAD FLATPACK - NO LEAD

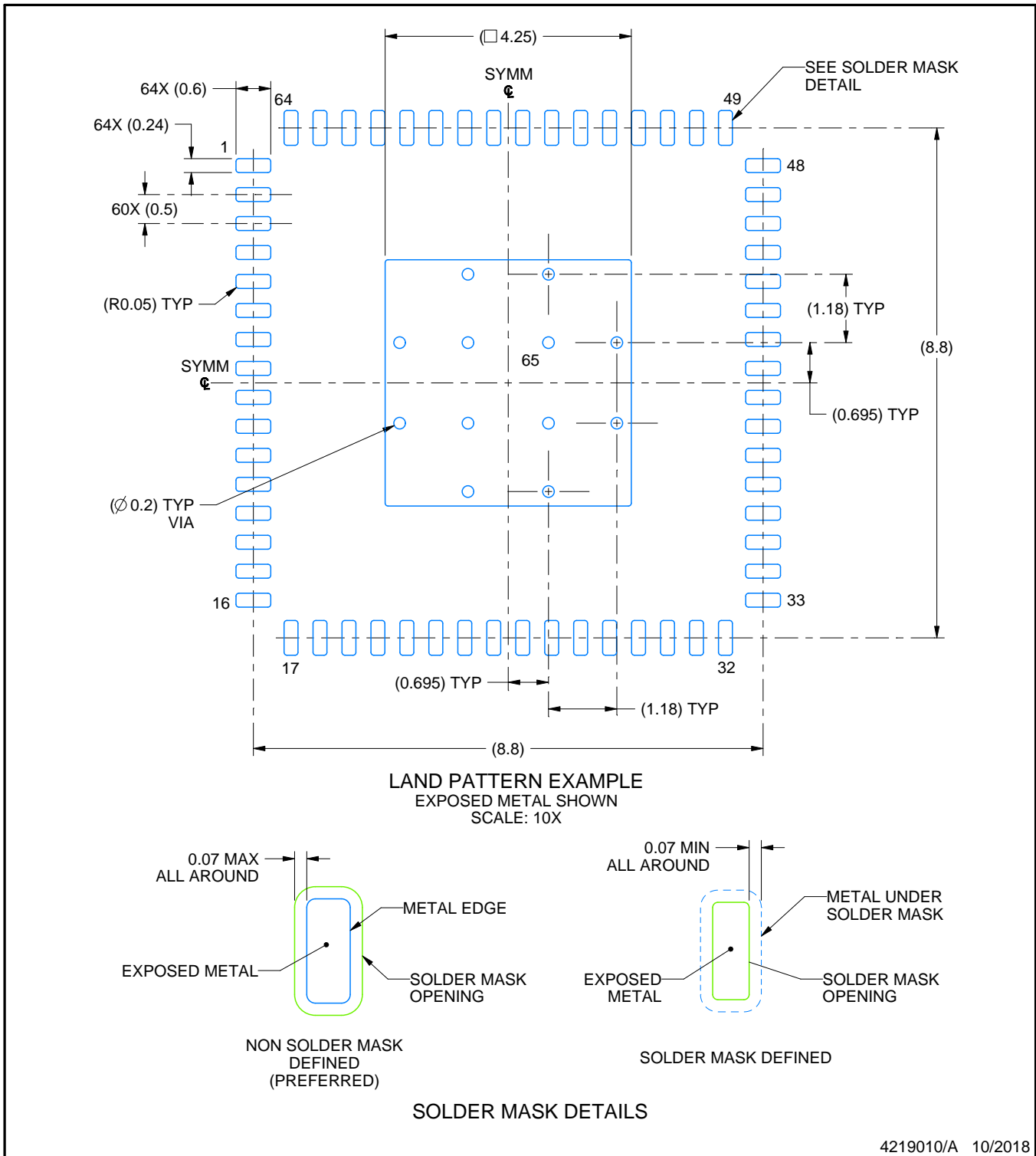

4219010/A 10/2018

NOTES: (continued)

4. This package is designed to be soldered to a thermal pad on the board. For more information, see Texas Instruments literature number SLUA271 (www.ti.com/lit/slue271).
5. Vias are optional depending on application, refer to device data sheet. If any vias are implemented, refer to their locations shown on this view. It is recommended that vias under paste be filled, plugged or tented.

EXAMPLE STENCIL DESIGN

RGC0064B

VQFN - 1 mm max height

PLASTIC QUAD FLATPACK - NO LEAD

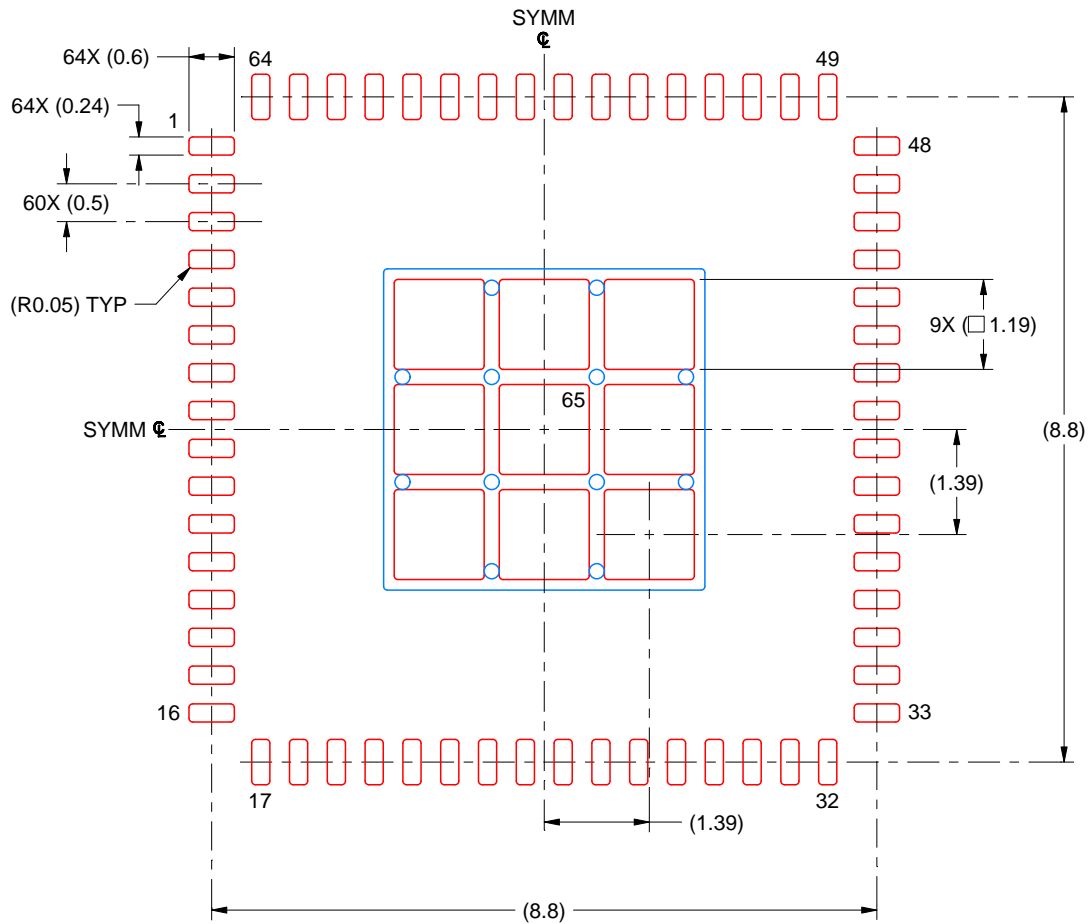

SOLDER PASTE EXAMPLE
BASED ON 0.125 MM THICK STENCIL
SCALE: 10X

EXPOSED PAD 65
71% PRINTED SOLDER COVERAGE BY AREA UNDER PACKAGE

4219010/A 10/2018

NOTES: (continued)

6. Laser cutting apertures with trapezoidal walls and rounded corners may offer better paste release. IPC-7525 may have alternate design recommendations.

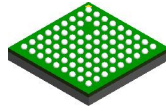

ZXH0080A

PACKAGE OUTLINE

NFBGA - 1 mm max height

BALL GRID ARRAY

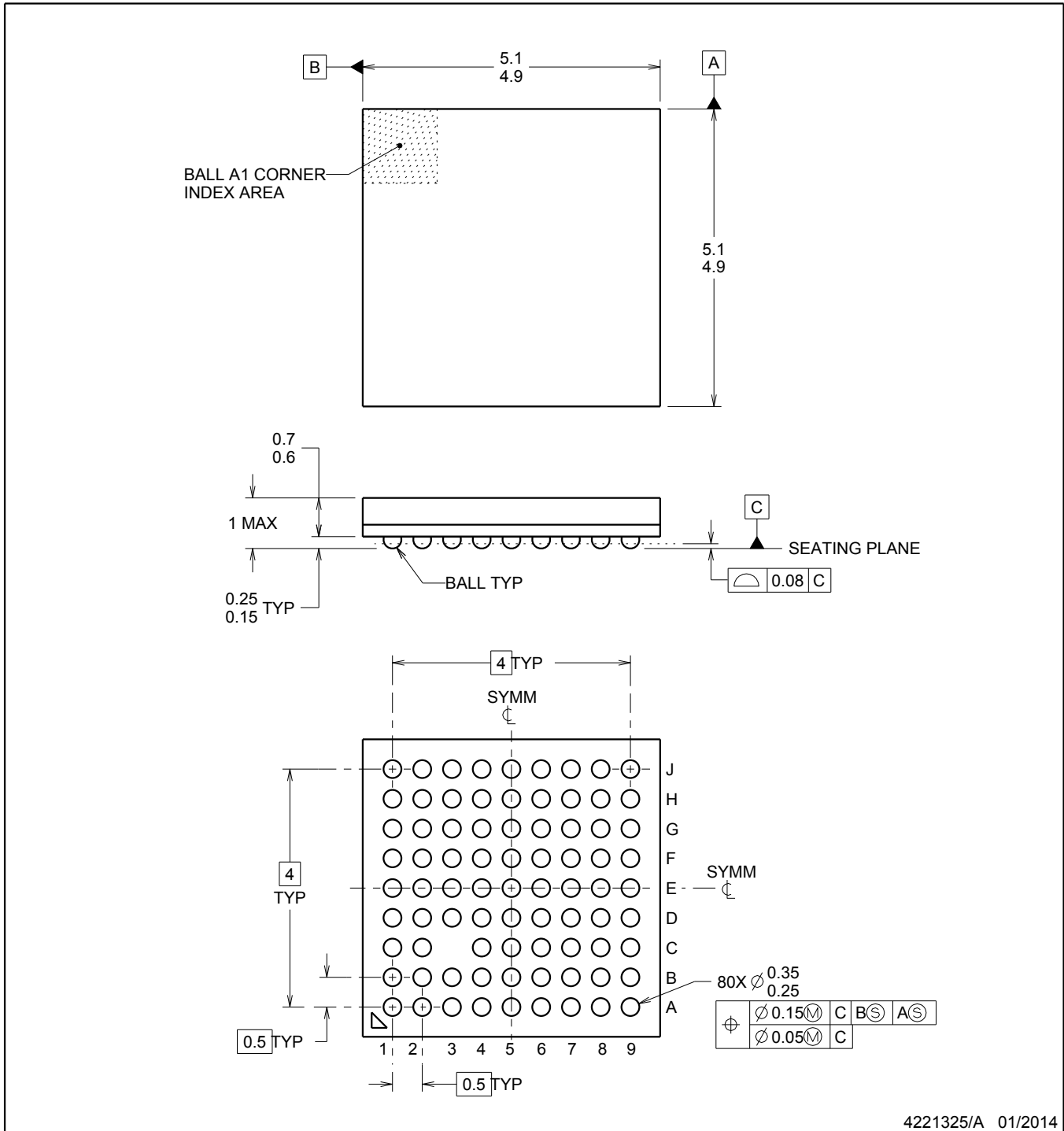

NOTES:

1. All linear dimensions are in millimeters. Any dimensions in parenthesis is for reference only. Dimensioning and tolerancing per ASME Y14.5M.
2. This drawing is subject to change without notice.
3. This is a Pb-free solder ball design.

EXAMPLE BOARD LAYOUT

ZXH0080A

NFBGA - 1 mm max height

BALL GRID ARRAY

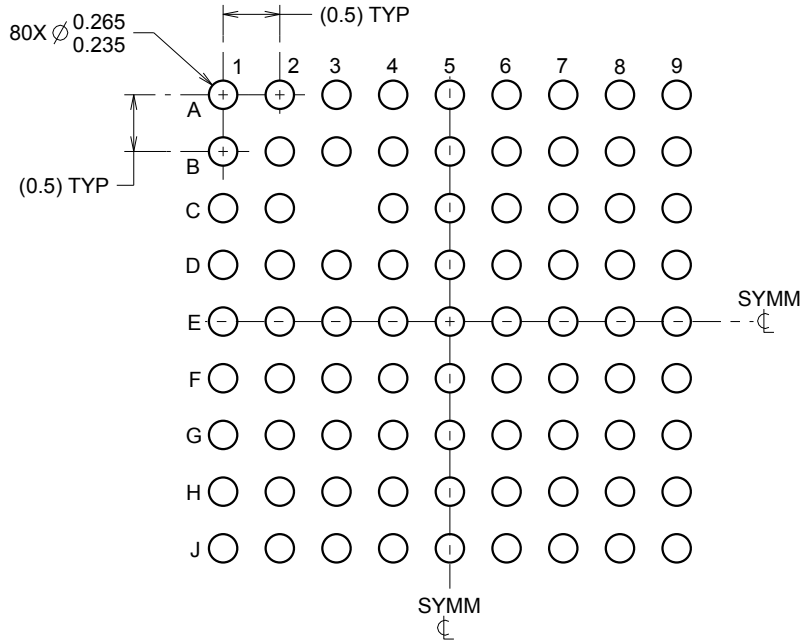

LAND PATTERN EXAMPLE
SCALE:15X

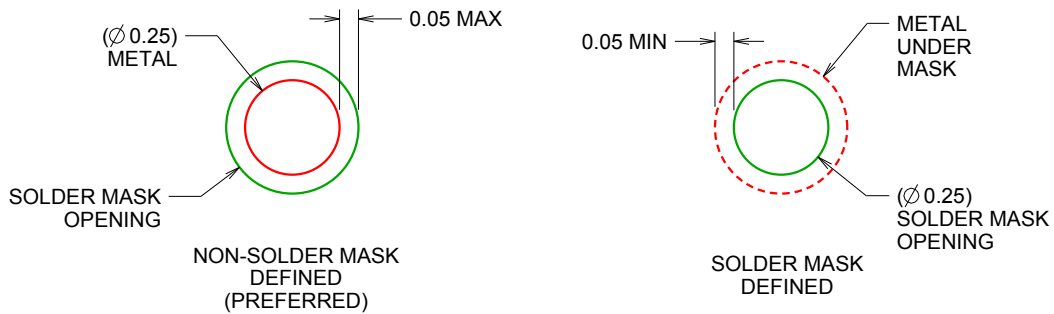

SOLDER MASK DETAILS
NOT TO SCALE

4221325/A 01/2014

NOTES: (continued)

- Final dimensions may vary due to manufacturing tolerance considerations and also routing constraints. See Texas Instruments Literature No. SBVA017 (www.ti.com/lit/sbva017).

EXAMPLE STENCIL DESIGN

ZXH0080A

NFBGA - 1 mm max height

BALL GRID ARRAY

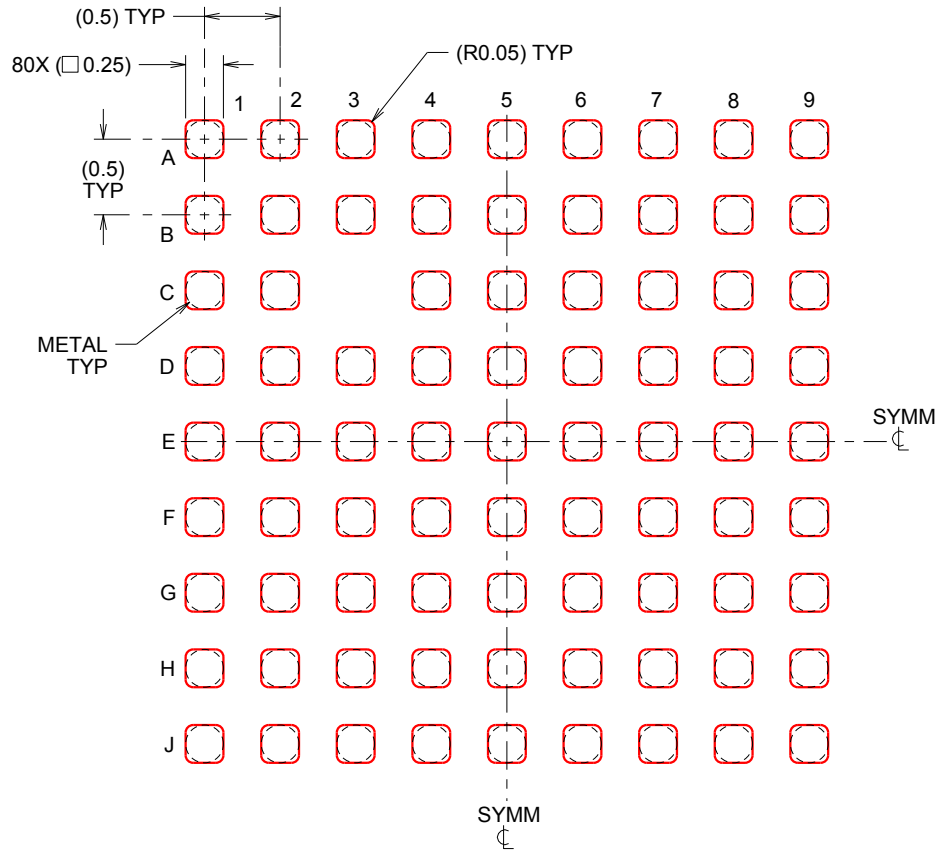

SOLDER PASTE EXAMPLE
BASED ON 0.1 mm THICK STENCIL
SCALE:20X

4221325/A 01/2014

NOTES: (continued)

4. Laser cutting apertures with trapezoidal walls and rounded corners may offer better paste release.

PN0080A

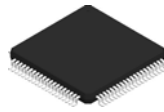

PACKAGE OUTLINE

LQFP - 1.6 mm max height

PLASTIC QUAD FLATPACK

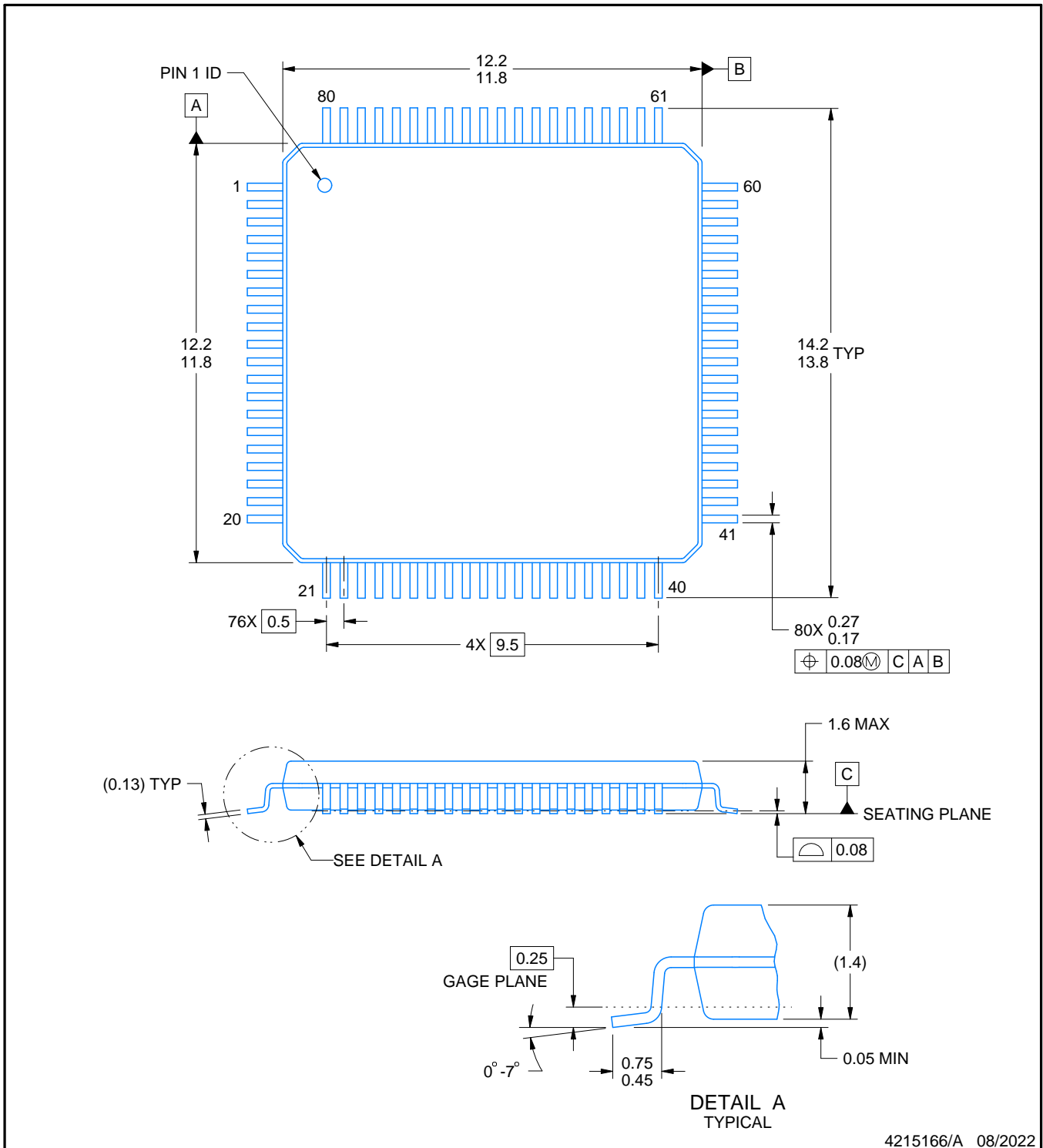

4215166/A 08/2022

NOTES:

1. All linear dimensions are in millimeters. Any dimensions in parenthesis are for reference only. Dimensioning and tolerancing per ASME Y14.5M.
2. This drawing is subject to change without notice.
3. Reference JEDEC registration MS-026.

EXAMPLE BOARD LAYOUT

PN0080A

LQFP - 1.6 mm max height

PLASTIC QUAD FLATPACK

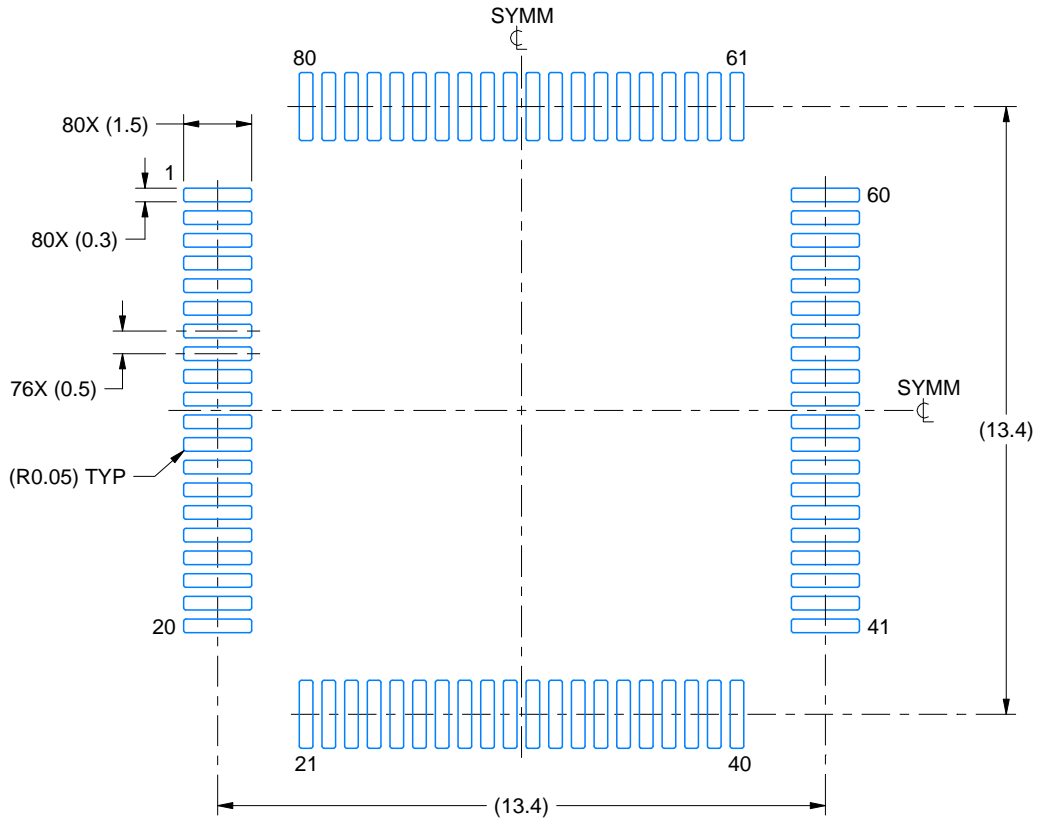

LAND PATTERN EXAMPLE
EXPOSED METAL SHOWN
SCALE:6X



SOLDER MASK DETAILS

4215166/A 08/2022

NOTES: (continued)

4. Publication IPC-7351 may have alternate designs.
5. Solder mask tolerances between and around signal pads can vary based on board fabrication site.
6. For more information, see Texas Instruments literature number SLMA004 (www.ti.com/lit/slma004).

EXAMPLE STENCIL DESIGN

PN0080A

LQFP - 1.6 mm max height

PLASTIC QUAD FLATPACK

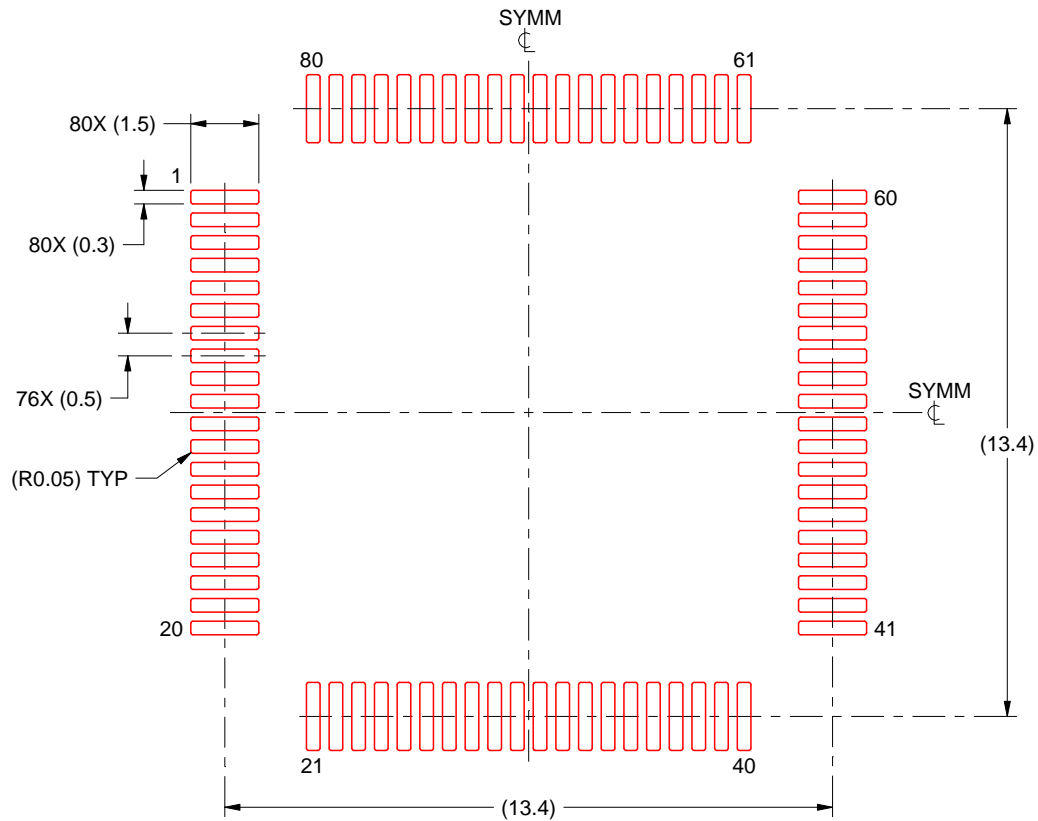

SOLDER PASTE EXAMPLE
BASED ON 0.1 mm THICK STENCIL
SCALE:6X

4215166/A 08/2022

NOTES: (continued)

7. Laser cutting apertures with trapezoidal walls and rounded corners may offer better paste release. IPC-7525 may have alternate design recommendations.
8. Board assembly site may have different recommendations for stencil design.

MECHANICAL DATA

YFF (R-XBGA-N64)

DIE-SIZE BALL GRID ARRAY

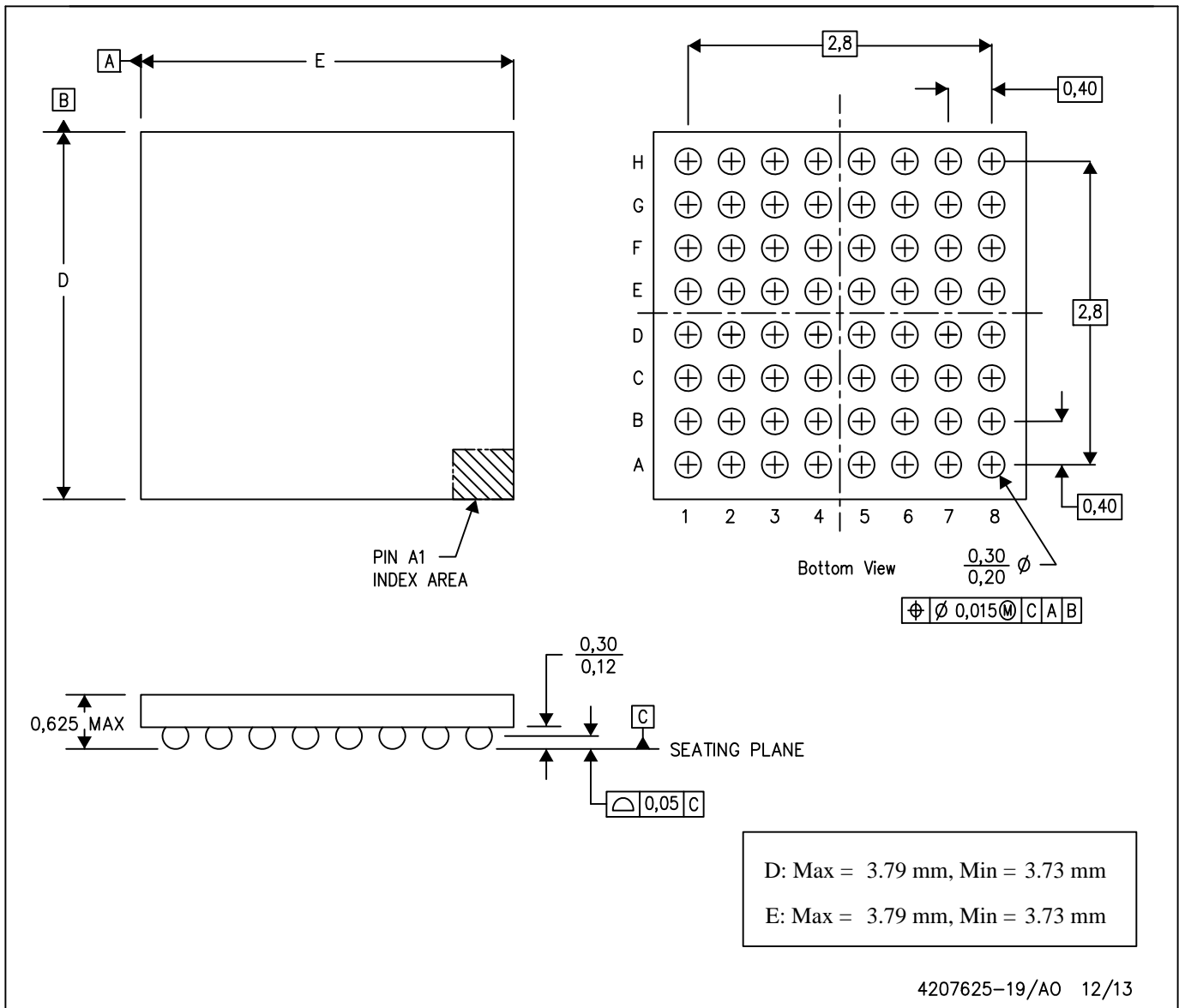

- NOTES: A. All linear dimensions are in millimeters. Dimensioning and tolerancing per ASME Y14.5M-1994.
B. This drawing is subject to change without notice.
C. NanoFree™ package configuration.

NanoFree is a trademark of Texas Instruments.

IMPORTANT NOTICE AND DISCLAIMER

TI PROVIDES TECHNICAL AND RELIABILITY DATA (INCLUDING DATA SHEETS), DESIGN RESOURCES (INCLUDING REFERENCE DESIGNS), APPLICATION OR OTHER DESIGN ADVICE, WEB TOOLS, SAFETY INFORMATION, AND OTHER RESOURCES "AS IS" AND WITH ALL FAULTS, AND DISCLAIMS ALL WARRANTIES, EXPRESS AND IMPLIED, INCLUDING WITHOUT LIMITATION ANY IMPLIED WARRANTIES OF MERCHANTABILITY, FITNESS FOR A PARTICULAR PURPOSE OR NON-INFRINGEMENT OF THIRD PARTY INTELLECTUAL PROPERTY RIGHTS.

These resources are intended for skilled developers designing with TI products. You are solely responsible for (1) selecting the appropriate TI products for your application, (2) designing, validating and testing your application, and (3) ensuring your application meets applicable standards, and any other safety, security, regulatory or other requirements.

These resources are subject to change without notice. TI grants you permission to use these resources only for development of an application that uses the TI products described in the resource. Other reproduction and display of these resources is prohibited. No license is granted to any other TI intellectual property right or to any third party intellectual property right. TI disclaims responsibility for, and you will fully indemnify TI and its representatives against, any claims, damages, costs, losses, and liabilities arising out of your use of these resources.

TI's products are provided subject to [TI's Terms of Sale](#) or other applicable terms available either on [ti.com](https://www.ti.com) or provided in conjunction with such TI products. TI's provision of these resources does not expand or otherwise alter TI's applicable warranties or warranty disclaimers for TI products.

TI objects to and rejects any additional or different terms you may have proposed.

Mailing Address: Texas Instruments, Post Office Box 655303, Dallas, Texas 75265
Copyright © 2024, Texas Instruments Incorporated

Looking for pricing, stock, or lifecycle information?

Click below to explore more details on WIN SOURCE:

⊖ [View MSP430F5529IPNR on WIN SOURCE](#)

⊖ [Texas Instruments](#) Information

Optimize Your Supply Chain with WIN SOURCE Solutions

- ✓ Global Sourcing Solution
- ✓ Obsolete Management
- ✓ Cost Control Management
- ✓ Shortage Management
- ✓ Alternative Solution
- ✓ Excess Inventory Management