



**THE DATASHEET OF  
MSP430F449IPZ**



# MSP430x43x1, MSP430x43x, MSP430x44x1, MSP430x44x MIXED SIGNAL MICROCONTROLLER

SLAS344G – JANUARY 2002 – REVISED OCTOBER 2009

- Low Supply-Voltage Range, 1.8 V to 3.6 V
- Ultralow-Power Consumption:
  - Active Mode: 280  $\mu$ A at 1 MHz, 2.2 V
  - Standby Mode: 1.1  $\mu$ A
  - Off Mode (RAM Retention): 0.1  $\mu$ A
- Five Power Saving Modes
- Wake-Up From Standby Mode in Less Than 6  $\mu$ s
- 16-Bit RISC Architecture, 125-ns Instruction Cycle Time
- 12-Bit A/D Converter With Internal Reference, Sample-and-Hold and Autoscan Feature
- 16-Bit Timer\_B With Three<sup>†</sup> or Seven<sup>‡</sup> Capture/Compare-With-Shadow Registers
- 16-Bit Timer\_A With Three Capture/Compare Registers
- On-Chip Comparator
- Serial Communication Interface (USART), Select Asynchronous UART or Synchronous SPI by Software:
  - Two USARTs (USART0, USART1)<sup>†</sup>
  - One USART (USART0)<sup>‡</sup>
- Brownout Detector
- Supply Voltage Supervisor/Monitor With Programmable Level Detection
- Serial Onboard Programming, No External Programming Voltage Needed  
Programmable Code Protection by Security Fuse
- Integrated LCD Driver for up to 160 Segments
- Bootstrap Loader
- Family Members Include:
  - MSP430F435, MSP430F4351<sup>§</sup>:  
16KB+256B Flash Memory, 512B RAM
  - MSP430F436, MSP430F4361<sup>§</sup>:  
24KB+256B Flash Memory, 1KB RAM
  - MSP430F437, MSP430F4371<sup>§</sup>:  
32KB+256B Flash Memory, 1KB RAM
  - MSP430F447:  
32KB+256B Flash Memory, 1KB RAM
  - MSP430F448, MSP430F4481<sup>§</sup>:  
48KB+256B Flash Memory, 2KB RAM
  - MSP430F449, MSP430F4491<sup>§</sup>:  
60KB+256B Flash Memory, 2KB RAM
- For Complete Module Descriptions, See The *MSP430x4xx Family User's Guide*, Literature Number SLAU056

<sup>†</sup> MSP430F43x, and MSP430F43x1 devices

<sup>‡</sup> MSP430F44x, and MSP430F44x1 devices

<sup>§</sup> The MSP430F43x1 and MSP430F44x1 devices are identical to the MSP430F43x and MSP430F44x devices, respectively – with the exception that the ADC12 module is not implemented.

## description

The Texas Instruments MSP430 family of ultralow power microcontrollers consists of several devices featuring different sets of peripherals targeted for various applications. The architecture, combined with five low-power modes, is optimized to achieve extended battery life in portable measurement applications. The devices feature a powerful 16-bit RISC CPU, 16-bit registers, and constant generators that contribute to maximum code efficiency. The digitally controlled oscillator (DCO) allows wake-up from low-power modes to active mode in less than 6  $\mu$ s.



This integrated circuit can be damaged by ESD. Texas Instruments recommends that all integrated circuits be handled with appropriate precautions. Failure to observe proper handling and installation procedures can cause damage. ESD damage can range from subtle performance degradation to complete device failure. Precision integrated circuits may be more susceptible to damage because very small parametric changes could cause the device not to meet its published specifications. These devices have limited built-in ESD protection.



Please be aware that an important notice concerning availability, standard warranty, and use in critical applications of Texas Instruments semiconductor products and disclaimers thereto appears at the end of this data sheet.

PRODUCTION DATA information is current as of publication date. Products conform to specifications per the terms of Texas Instruments standard warranty. Production processing does not necessarily include testing of all parameters.

**TEXAS  
INSTRUMENTS**

POST OFFICE BOX 655303 • DALLAS, TEXAS 75265

Copyright © 2009, Texas Instruments Incorporated

# MSP430x43x1, MSP430x43x, MSP430x44x1, MSP430x44x MIXED SIGNAL MICROCONTROLLER

SLAS344G – JANUARY 2002 – REVISED OCTOBER 2009

## description (continued)

The MSP430x43x(1) and the MSP430x44x(1) series are microcontroller configurations with two built-in 16-bit timers, a fast 12-bit A/D converter (not implemented on the MSP430F43x1 and MSP430F44x1 devices), one or two universal serial synchronous/asynchronous communication interfaces (USART), 48 I/O pins, and a liquid crystal driver (LCD) with up to 160 segments.

Typical applications include sensor systems that capture analog signals, convert them to digital values, and process and transmit the data to a host system, or process this data and display it on a LCD panel. The timers make the configurations ideal for industrial control applications such as ripple counters, digital motor control, EE-meters, hand-held meters, etc. The hardware multiplier enhances the performance and offers a broad code and hardware-compatible family solution.

AVAILABLE OPTIONS <sup>†</sup>		
T <sub>A</sub>	PACKAGED DEVICES <sup>‡</sup>	
	PLASTIC 80-PIN QFP (PN)	PLASTIC 100-PIN QFP (PZ)
-40°C to 85°C	MSP430F435IPN MSP430F436IPN MSP430F437IPN	MSP430F435IPZ MSP430F436IPZ MSP430F437IPZ
	MSP430F4351IPN MSP430F4361IPN MSP430F4371IPN	MSP430F4351IPZ MSP430F4361IPZ MSP430F4371IPZ
		MSP430F447IPZ MSP430F448IPZ MSP430F449IPZ
		MSP430F4481IPZ MSP430F4491IPZ

<sup>†</sup> For the most current package and ordering information, see the Package Option Addendum at the end of this document, or see the TI web site at [www.ti.com](http://www.ti.com).

<sup>‡</sup> Package drawings, thermal data, and symbolization are available at [www.ti.com/packaging](http://www.ti.com/packaging).

## DEVELOPMENT TOOL SUPPORT

All MSP430 microcontrollers include an Embedded Emulation Module (EEM) allowing advanced debugging and programming through easy to use development tools. Recommended hardware options include the following:

- Debugging and Programming Interface
  - MSP-FET430UIF (USB)
  - MSP-FET430PIF (Parallel Port)
- Debugging and Programming Interface with Target Board
  - MSP-FET430U100 (PZ package)
- Stand-Alone Target Board
  - MSP-TS430PZ100 (PZ package)
- Production Programmer
  - MSP-GANG430



# MSP430x43x1, MSP430x43x, MSP430x44x1, MSP430x44x MIXED SIGNAL MICROCONTROLLER

SLAS344G – JANUARY 2002 – REVISED OCTOBER 2009

## pin designation, MSP430x4351IPN, MSP430x4361IPN, MSP430x4371IPN

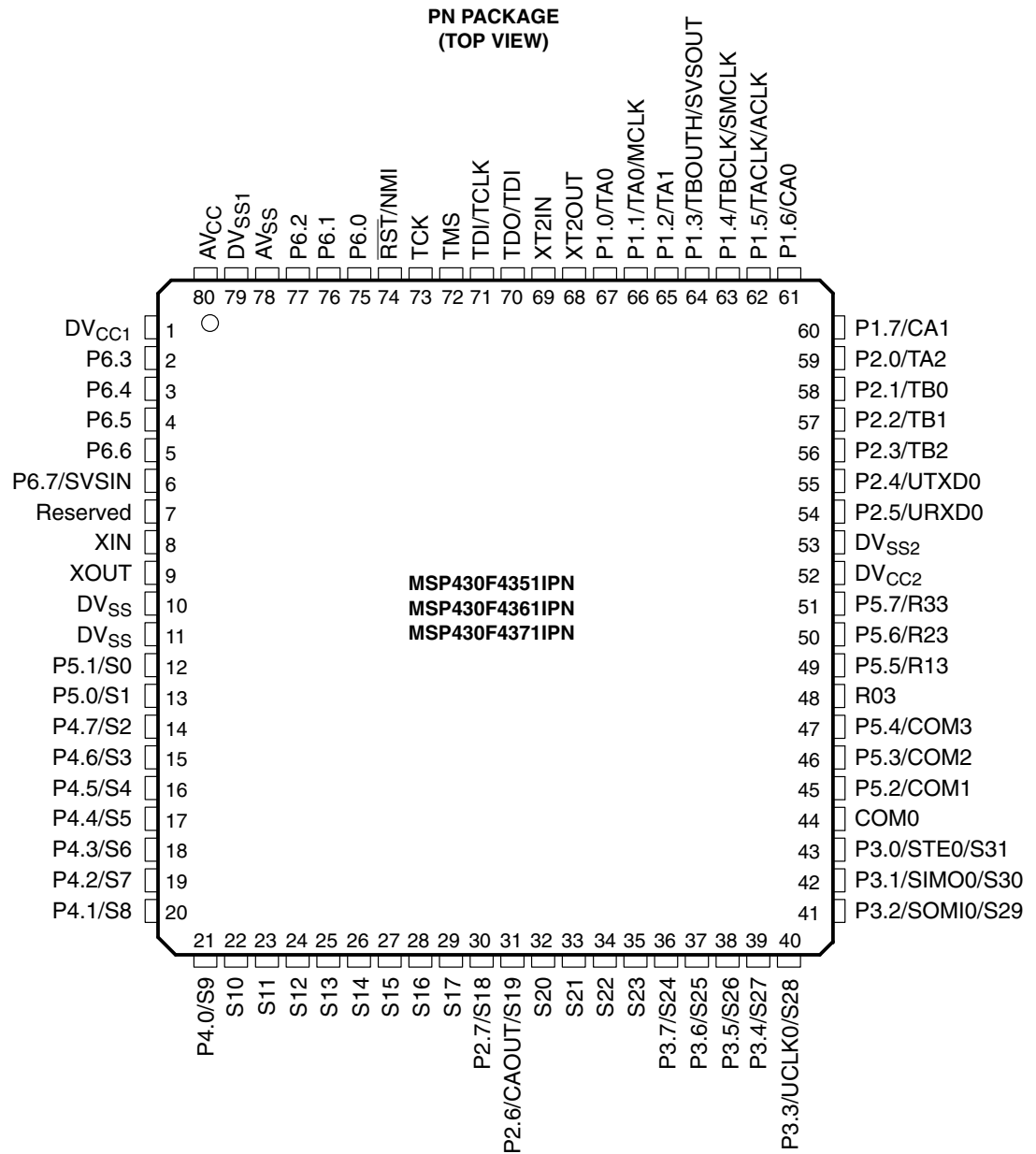

# MSP430x43x1, MSP430x43x, MSP430x44x1, MSP430x44x MIXED SIGNAL MICROCONTROLLER

SLAS344G – JANUARY 2002 – REVISED OCTOBER 2009

## pin designation, MSP430x4351IPZ, MSP430x4361IPZ, MSP430x4371IPZ

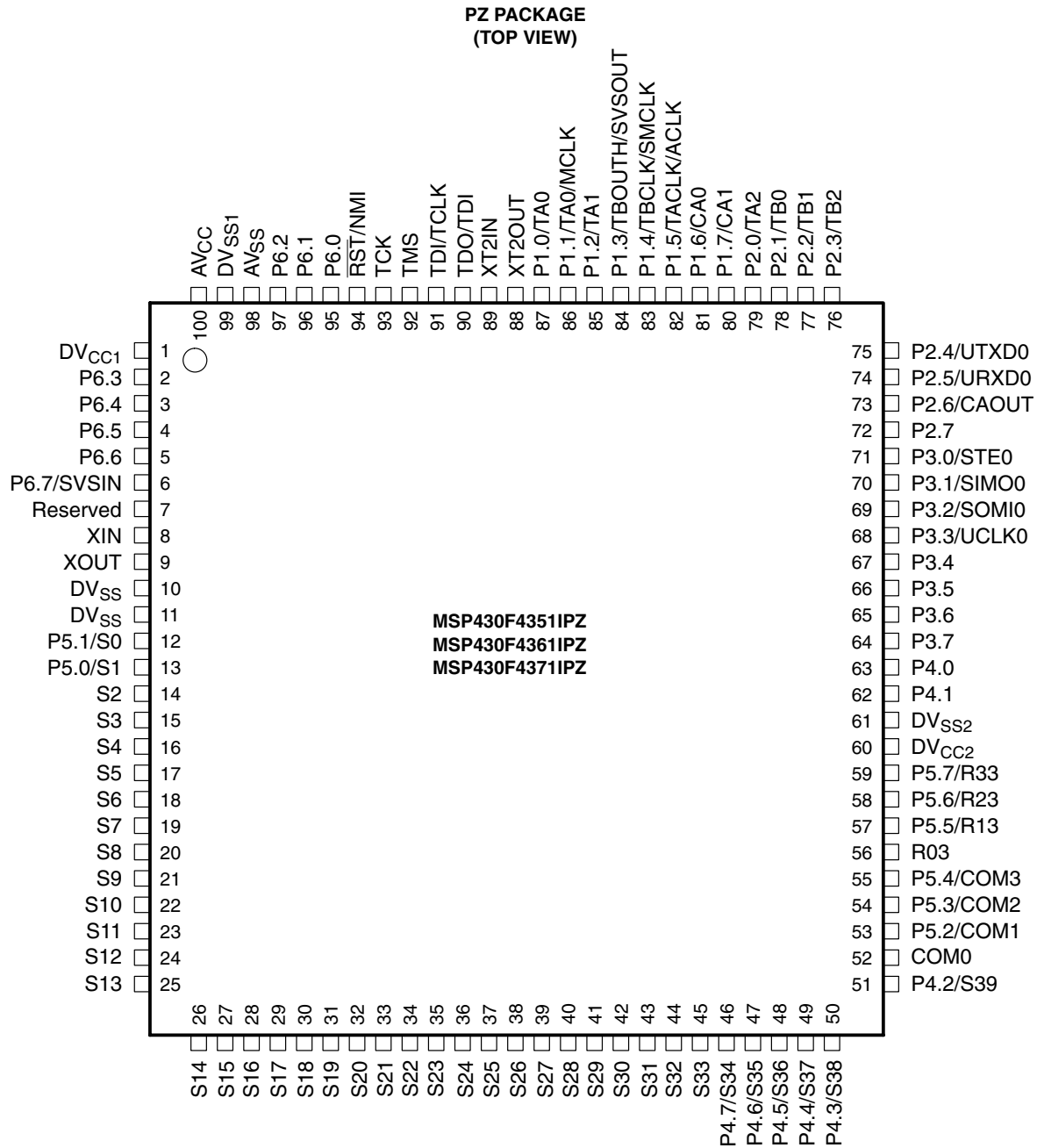

# MSP430x43x1, MSP430x43x, MSP430x44x1, MSP430x44x MIXED SIGNAL MICROCONTROLLER

SLAS344G – JANUARY 2002 – REVISED OCTOBER 2009

## pin designation, MSP430x435IPN, MSP430x436IPN, MSP430x437IPN

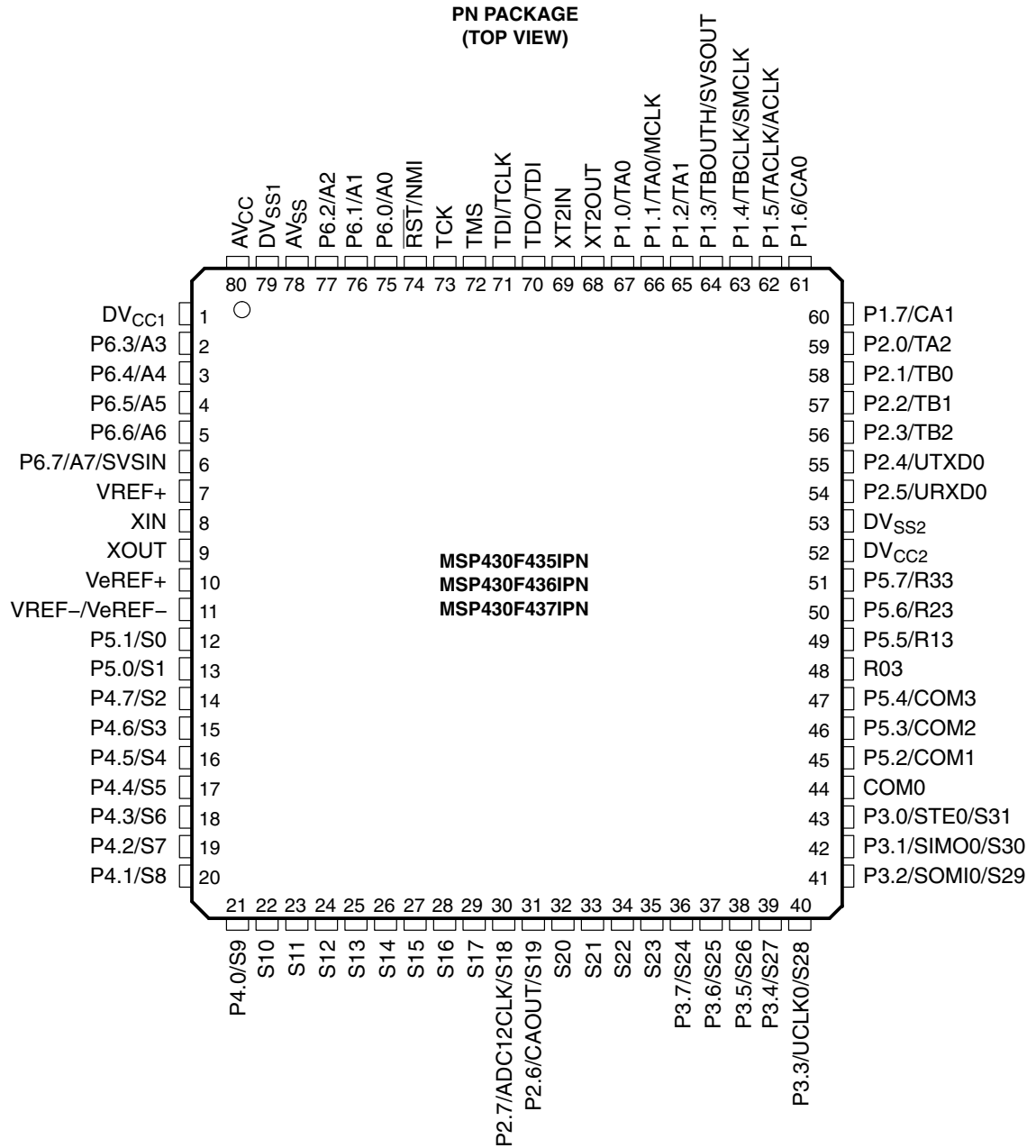

# MSP430x43x1, MSP430x43x, MSP430x44x1, MSP430x44x MIXED SIGNAL MICROCONTROLLER

SLAS344G – JANUARY 2002 – REVISED OCTOBER 2009

## pin designation, MSP430x435IPZ, MSP430x436IPZ, MSP430x437IPZ

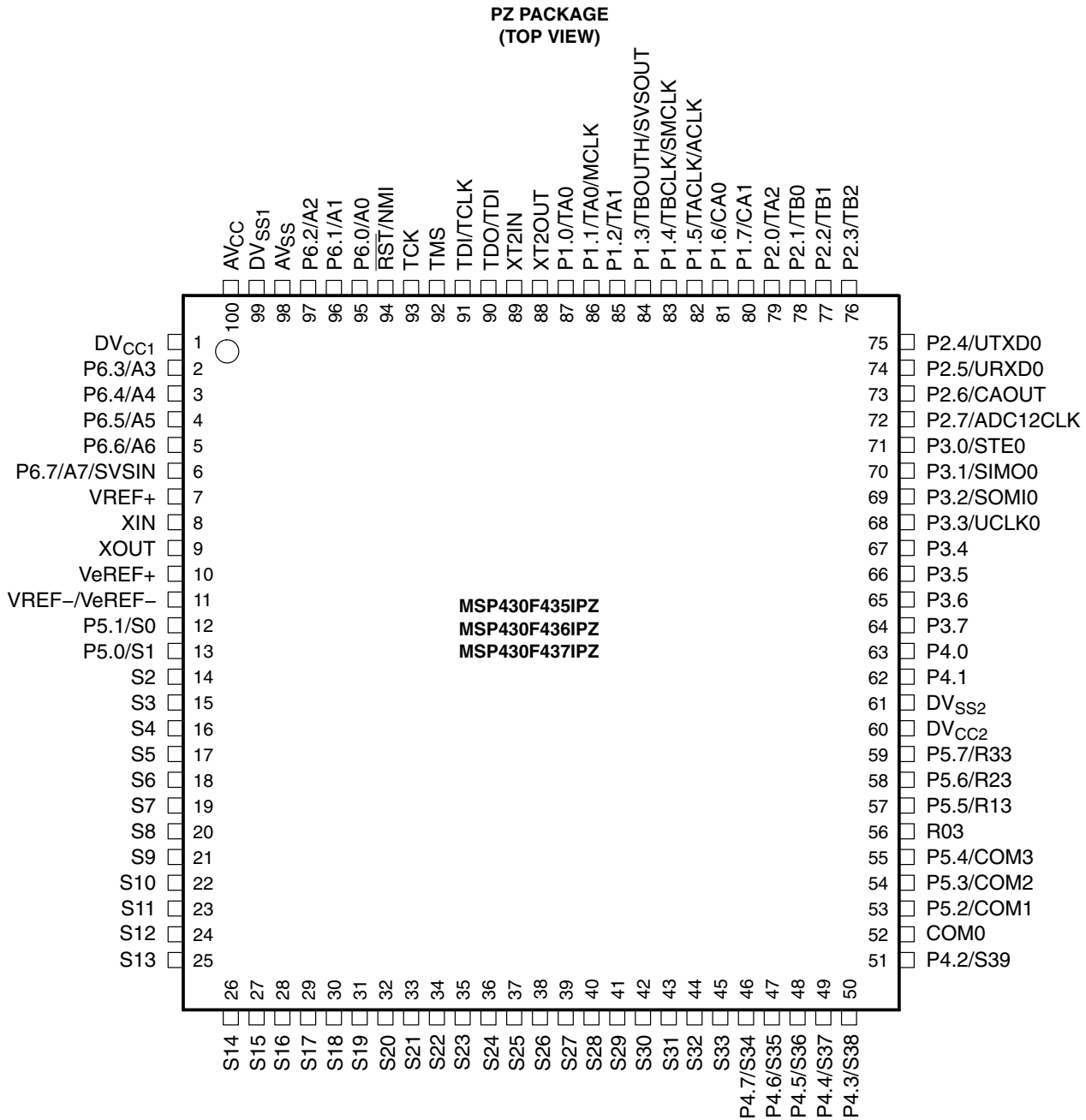

# MSP430x43x1, MSP430x43x, MSP430x44x1, MSP430x44x MIXED SIGNAL MICROCONTROLLER

SLAS344G – JANUARY 2002 – REVISED OCTOBER 2009

## pin designation, MSP430x4481IPZ, MSP430x4491IPZ

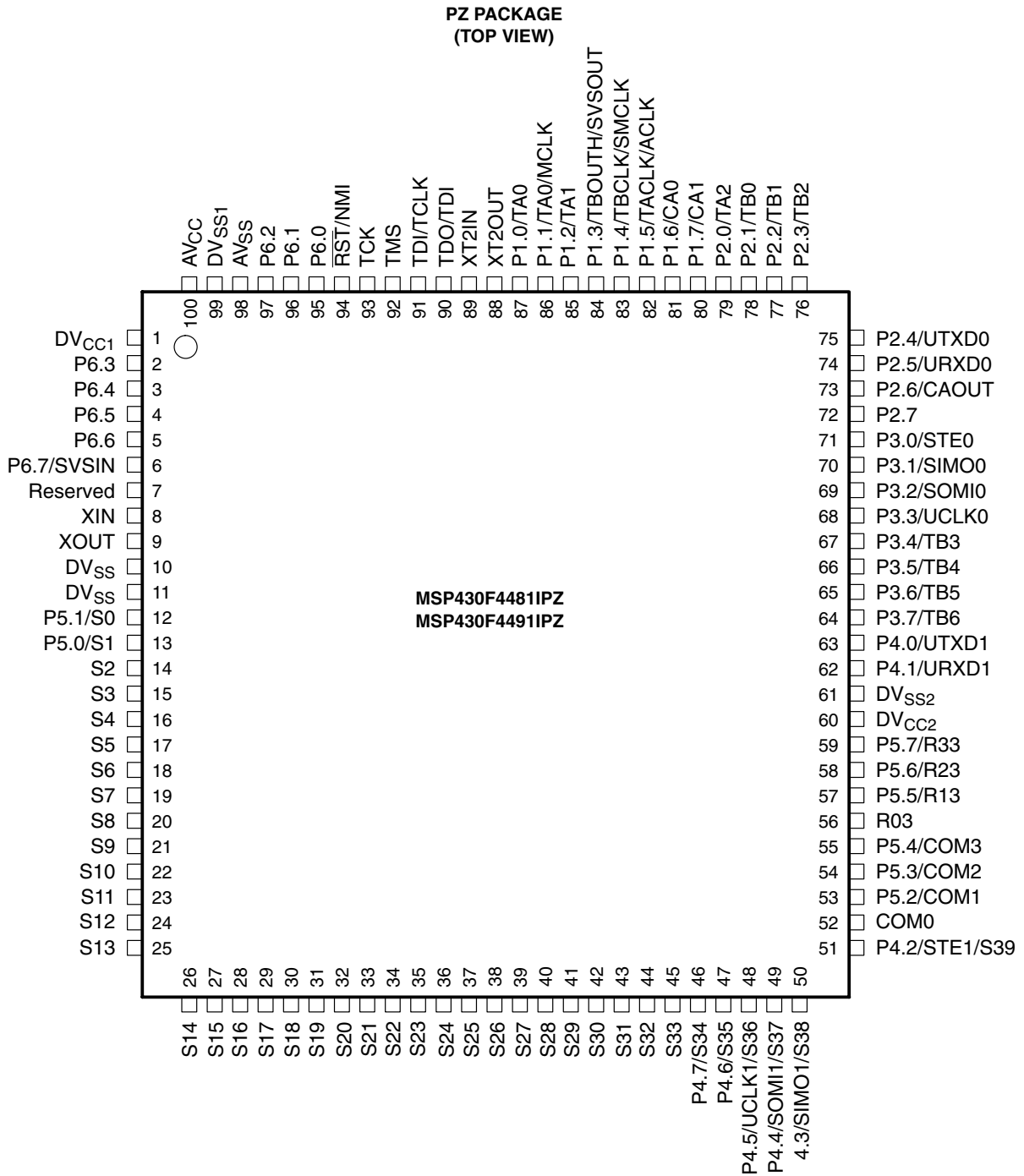

# MSP430x43x1, MSP430x43x, MSP430x44x1, MSP430x44x MIXED SIGNAL MICROCONTROLLER

SLAS344G – JANUARY 2002 – REVISED OCTOBER 2009

## pin designation, MSP430x447IPZ, MSP430x448IPZ, MSP430x449IPZ

PZ PACKAGE  
(TOP VIEW)

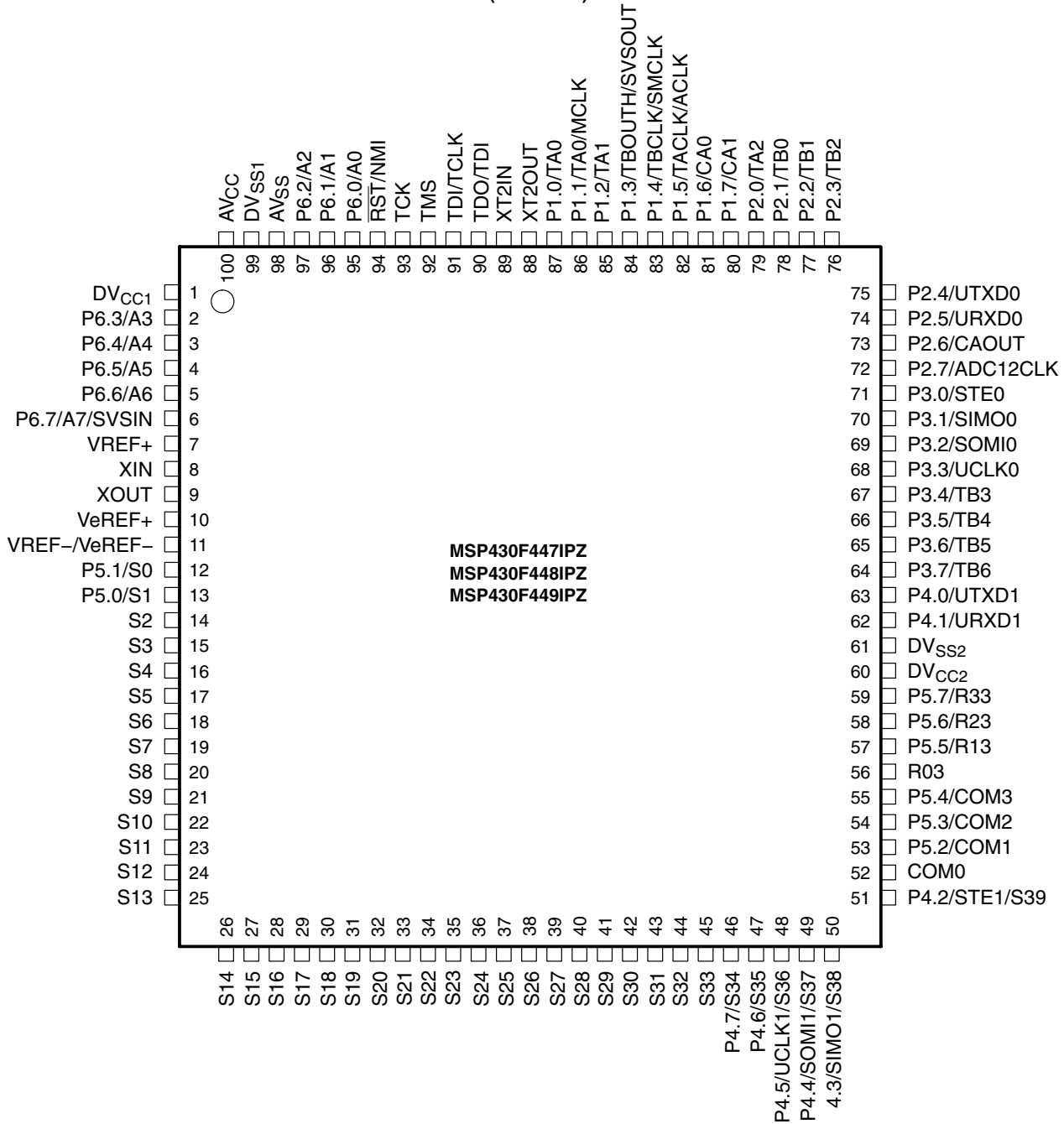

POST OFFICE BOX 655303 • DALLAS, TEXAS 75265

# MSP430x43x1, MSP430x43x, MSP430x44x1, MSP430x44x MIXED SIGNAL MICROCONTROLLER

SLAS344G – JANUARY 2002 – REVISED OCTOBER 2009

## MSP430x43x1 functional block diagram

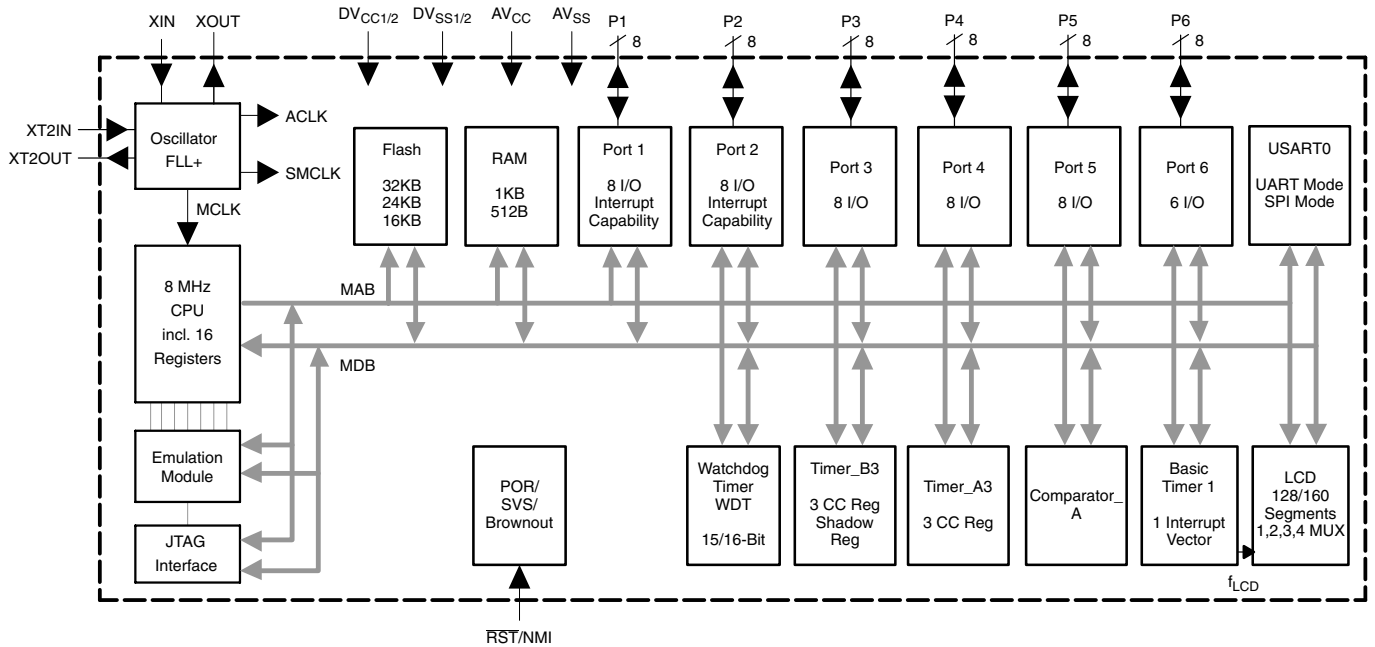

## MSP430x43x functional block diagram

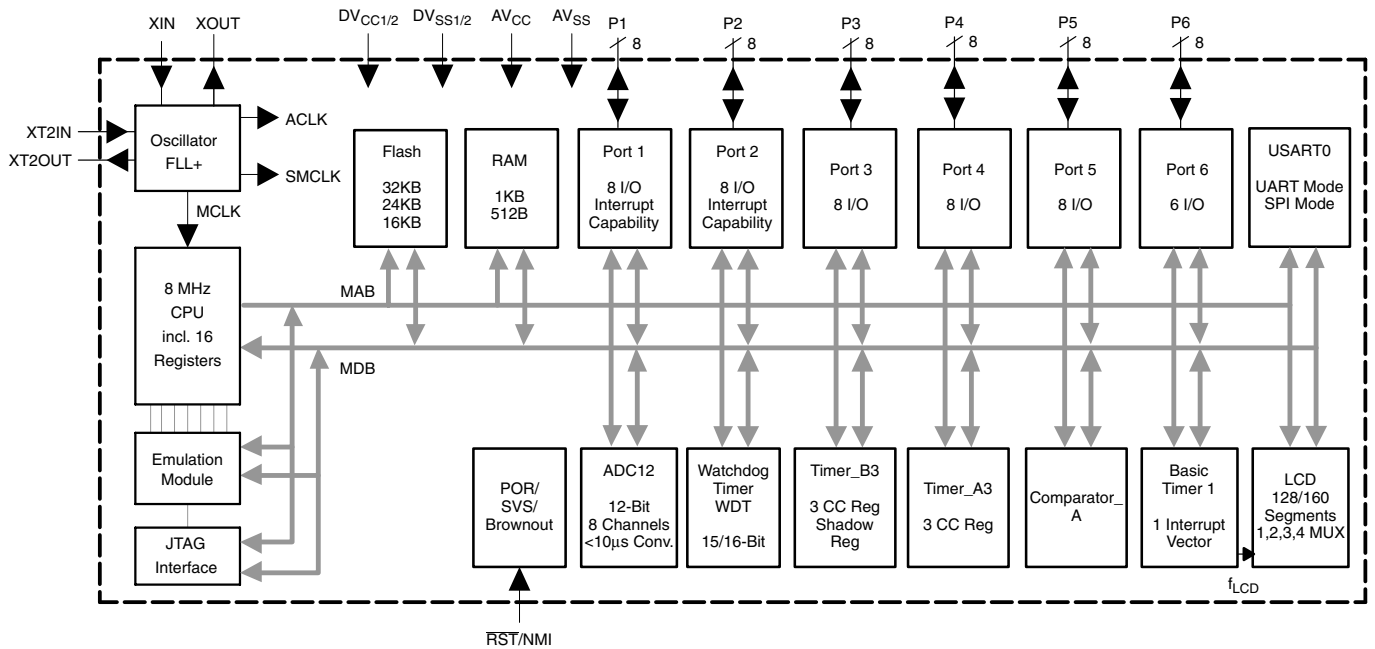

# MSP430x43x1, MSP430x43x, MSP430x44x1, MSP430x44x MIXED SIGNAL MICROCONTROLLER

SLAS344G – JANUARY 2002 – REVISED OCTOBER 2009

## MSP430x44x1 functional block diagram

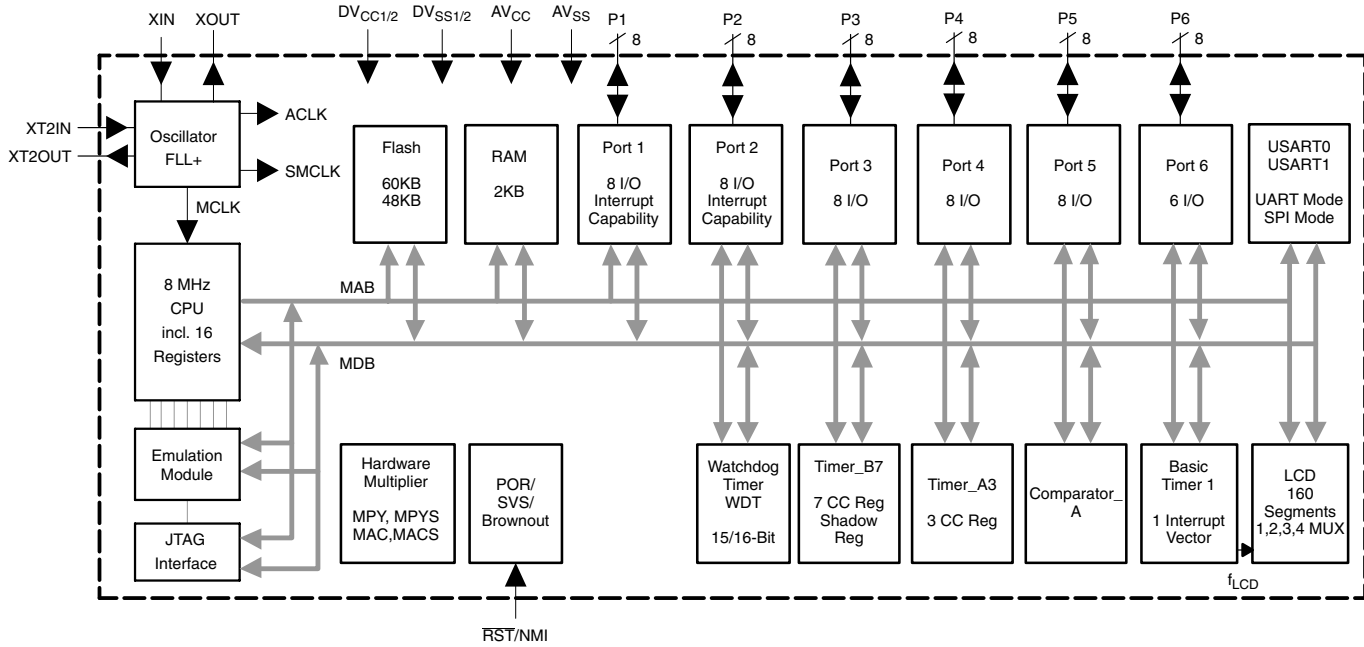

## MSP430x44x functional block diagram

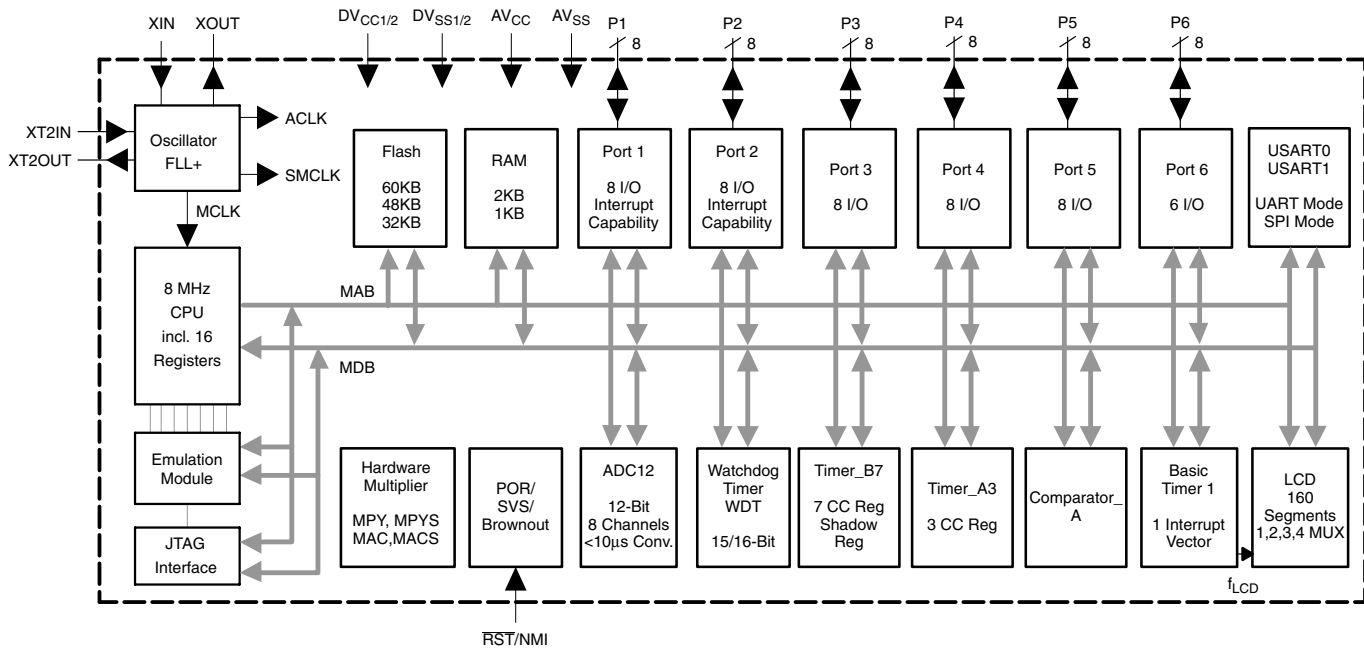

# MSP430x43x1, MSP430x43x, MSP430x44x1, MSP430x44x MIXED SIGNAL MICROCONTROLLER

SLAS344G – JANUARY 2002 – REVISED OCTOBER 2009

## MSP430x43x1 Terminal Functions

TERMINAL					DESCRIPTION	
PN NAME	NO.	I/O	PZ NAME	NO.		I/O
DV <sub>CC1</sub>	1		DV <sub>CC1</sub>	1		Digital supply voltage, positive terminal.
P6.3	2	I/O	P6.3	2	I/O	General-purpose digital I/O
P6.4	3	I/O	P6.4	3	I/O	General-purpose digital I/O
P6.5	4	I/O	P6.5	4	I/O	General-purpose digital I/O
P6.6	5	I/O	P6.6	5	I/O	General-purpose digital I/O
P6.7/SVSIN	6	I/O	P6.7/SVSIN	6	I/O	General-purpose digital I/O / input to brownout, supply voltage supervisor
Reserved	7		Reserved	7		Reserved, do not connect externally
XIN	8	I	XIN	8	I	Input port for crystal oscillator XT1. Standard or watch crystals can be connected.
XOUT	9	O	XOUT	9	O	Output terminal of crystal oscillator XT1
DV <sub>SS</sub>	10	I	DV <sub>SS</sub>	10	I	Connect to DV <sub>SS</sub>
DV <sub>SS</sub>	11	I	DV <sub>SS</sub>	11	I	Connect to DV <sub>SS</sub>
P5.1/S0	12	I/O	P5.1/S0	12	I/O	General-purpose digital I/O / LCD segment output 0
P5.0/S1	13	I/O	P5.0/S1	13	I/O	General-purpose digital I/O / LCD segment output 1
P4.7/S2	14	I/O	S2	14	O	General-purpose digital I/O / LCD segment output 2
P4.6/S3	15	I/O	S3	15	O	General-purpose digital I/O / LCD segment output 3
P4.5/S4	16	I/O	S4	16	O	General-purpose digital I/O / LCD segment output 4
P4.4/S5	17	I/O	S5	17	O	General-purpose digital I/O / LCD segment output 5
P4.3/S6	18	I/O	S6	18	O	General-purpose digital I/O / LCD segment output 6
P4.2/S7	19	I/O	S7	19	O	General-purpose digital I/O / LCD segment output 7
P4.1/S8	20	I/O	S8	20	O	General-purpose digital I/O / LCD segment output 8
P4.0/S9	21	I/O	S9	21	O	General-purpose digital I/O / LCD segment output 9
S10	22	O	S10	22	O	LCD segment output 10
S11	23	O	S11	23	O	LCD segment output 11
S12	24	O	S12	24	O	LCD segment output 12
S13	25	O	S13	25	O	LCD segment output 13
S14	26	O	S14	26	O	LCD segment output 14
S15	27	O	S15	27	O	LCD segment output 15
S16	28	O	S16	28	O	LCD segment output 16
S17	29	O	S17	29	O	LCD segment output 17
P2.7/S18	30	I/O	S18	30	O	General-purpose digital I/O / LCD segment output 18
P2.6/CAOUT/S19	31	I/O	S19	31	O	General-purpose digital I/O / Comparator_A output / LCD segment output 19
S20	32	O	S20	32	O	LCD segment output 20
S21	33	O	S21	33	O	LCD segment output 21
S22	34	O	S22	34	O	LCD segment output 22
S23	35	O	S23	35	O	LCD segment output 23
P3.7/S24	36	I/O	S24	36	O	General-purpose digital I/O / LCD segment output 24
P3.6/S25	37	I/O	S25	37	O	General-purpose digital I/O / LCD segment output 25
P3.5/S26	38	I/O	S26	38	O	General-purpose digital I/O / LCD segment output 26
P3.4/S27	39	I/O	S27	39	O	General-purpose digital I/O / LCD segment output 27



# MSP430x43x1, MSP430x43x, MSP430x44x1, MSP430x44x MIXED SIGNAL MICROCONTROLLER

SLAS344G – JANUARY 2002 – REVISED OCTOBER 2009

## MSP430x43x1 Terminal Functions (Continued)

TERMINAL					DESCRIPTION	
PN NAME	NO.	I/O	PZ NAME	NO.		
P3.3/UCLK0/S28	40	I/O	S28	40	O	General-purpose digital I/O / ext. clock i/p—USART0/UART or SPI mode, clock o/p—USART0/SPI mode / LCD segment output 28
P3.2/SOMI0/S29	41	I/O	S29	41	O	General-purpose digital I/O / slave out/master in of USART0/SPI mode / LCD segment output 29
P3.1/SIMO0/S30	42	I/O	S30	42	O	General-purpose digital I/O / slave out/master out of USART0/SPI mode / LCD segment output 30
P3.0/STE0/S31	43	I/O	S31	43	O	General-purpose digital I/O / slave transmit enable-USART0/SPI mode / LCD segment output 31
			S32	44	O	LCD segment output 32
			S33	45	O	LCD segment output 33
			P4.7/S34	46	I/O	General-purpose digital I/O / LCD segment output 34
			P4.6/S35	47	I/O	General-purpose digital I/O / LCD segment output 35
			P4.5/S36	48	I/O	General-purpose digital I/O / LCD segment output 36
			P4.4/S37	49	I/O	General-purpose digital I/O / LCD segment output 37
			P4.3/S38	50	I/O	General-purpose digital I/O / LCD segment output 38
			P4.2/S39	51	I/O	General-purpose digital I/O / LCD segment output 39
COM0	44	O	COM0	52	O	COM0–3 are used for LCD backplanes.
P5.2/COM1	45	I/O	P5.2/COM1	53	I/O	General-purpose digital I/O / common output, COM0–3 are used for LCD backplanes.
P5.3/COM2	46	I/O	P5.3/COM2	54	I/O	General-purpose digital I/O / common output, COM0–3 are used for LCD backplanes.
P5.4/COM3	47	I/O	P5.4/COM3	55	I/O	General-purpose digital I/O / common output, COM0–3 are used for LCD backplanes.
R03	48	I	R03	56	I	Input port of fourth positive (lowest) analog LCD level (V5)
P5.5/R13	49	I/O	P5.5/R13	57	I/O	General-purpose digital I/O / input port of third most positive analog LCD level (V4 or V3)
P5.6/R23	50	I/O	P5.6/R23	58	I/O	General-purpose digital I/O / input port of second most positive analog LCD level (V2)
P5.7/R33	51	I/O	P5.7/R33	59	I/O	General-purpose digital I/O / output port of most positive analog LCD level (V1)
DV <sub>CC2</sub>	52		DV <sub>CC2</sub>	60		Digital supply voltage, positive terminal.
DV <sub>SS2</sub>	53		DV <sub>SS2</sub>	61		Digital supply voltage, negative terminal.
			P4.1	62	I/O	General-purpose digital I/O
			P4.0	63	I/O	General-purpose digital I/O
			P3.7	64	I/O	General-purpose digital I/O
			P3.6	65	I/O	General-purpose digital I/O
			P3.5	66	I/O	General-purpose digital I/O
			P3.4	67	I/O	General-purpose digital I/O
			P3.3/UCLK0	68	I/O	General-purpose digital I/O / external clock input—USART0/UART or SPI mode, clock output—USART0/SPI mode
			P3.2/SOMI0	69	I/O	General-purpose digital I/O / slave out/master in of USART0/SPI mode
			P3.1/SIMO0	70	I/O	General-purpose digital I/O / slave in/master out of USART0/SPI mode
			P3.0/STE0	71	I/O	General-purpose digital I/O / slave transmit enable USART0/SPI mode
			P2.7	72	I/O	General-purpose digital I/O
			P2.6/CAOUT	73	I/O	General-purpose digital I/O / Comparator_A output
P2.5/URXD0	54	I/O	P2.5/URXD0	74	I/O	General-purpose digital I/O / receive data in—USART0/UART mode



# MSP430x43x1, MSP430x43x, MSP430x44x1, MSP430x44x MIXED SIGNAL MICROCONTROLLER

SLAS344G – JANUARY 2002 – REVISED OCTOBER 2009

## MSP430x43x1 Terminal Functions (Continued)

TERMINAL						DESCRIPTION
PN NAME	NO.	I/O	PZ NAME	NO.	I/O	
P2.4/UTXD0	55	I/O	P2.4/UTXD0	75	I/O	General-purpose digital I/O / transmit data out—USART0/UART mode
P2.3/TB2	56	I/O	P2.3/TB2	76	I/O	General-purpose digital I/O / Timer_B3 CCR2. Capture: CCI2A/CCI2B input, compare: Out2 output
P2.2/TB1	57	I/O	P2.2/TB1	77	I/O	General-purpose digital I/O / Timer_B3 CCR1. Capture: CCI1A/CCI1B input, compare: Out1 output
P2.1/TB0	58	I/O	P2.1/TB0	78	I/O	General-purpose digital I/O / Timer_B3 CCR0. Capture: CCI0A/CCI0B input, compare: Out0 output
P2.0/TA2	59	I/O	P2.0/TA2	79	I/O	General-purpose digital I/O / Timer_A Capture: CCI2A input, compare: Out2 output
P1.7/CA1	60	I/O	P1.7/CA1	80	I/O	General-purpose digital I/O / Comparator_A input
P1.6/CA0	61	I/O	P1.6/CA0	81	I/O	General-purpose digital I/O / Comparator_A input
P1.5/TACLK/ ACLK	62	I/O	P1.5/TACLK/ ACLK	82	I/O	General-purpose digital I/O / Timer_A, clock signal TACLK input / ACLK output (divided by 1, 2, 4, or 8)
P1.4/TBCLK/ SMCLK	63	I/O	P1.4/TBCLK/ SMCLK	83	I/O	General-purpose digital I/O / input clock TBCLK—Timer_B3 / submain system clock SMCLK output
P1.3/TBOUTH/ SVSOUT	64	I/O	P1.3/TBOUTH/ SVSOUT	84	I/O	General-purpose digital I/O / switch all PWM digital output ports to high impedance—Timer_B3 TB0 to TB2 / SVS: output of SVS comparator
P1.2/TA1	65	I/O	P1.2/TA1	85	I/O	General-purpose digital I/O / Timer_A, Capture: CCI1A input, compare: Out1 output
P1.1/TA0/MCLK	66	I/O	P1.1/TA0/MCLK	86	I/O	General-purpose digital I/O / Timer_A. Capture: CCI0B input / MCLK output. Note: TA0 is only an input on this pin / BSL receive
P1.0/TA0	67	I/O	P1.0/TA0	87	I/O	General-purpose digital I/O / Timer_A. Capture: CCI0A input, compare: Out0 output / BSL transmit
XT2OUT	68	O	XT2OUT	88	O	Output terminal of crystal oscillator XT2
XT2IN	69	I	XT2IN	89	I	Input port for crystal oscillator XT2. Only standard crystals can be connected.
TDO/TDI	70	I/O	TDO/TDI	90	I/O	Test data output port. TDO/TDI data output or programming data input terminal
TDI/TCLK	71	I	TDI/TCLK	91	I	Test data input or test clock input. The device protection fuse is connected to TDI/TCLK.
TMS	72	I	TMS	92	I	Test mode select. TMS is used as an input port for device programming and test.
TCK	73	I	TCK	93	I	Test clock. TCK is the clock input port for device programming and test.
RST/NMI	74	I	RST/NMI	94	I	General-purpose digital I/O / reset input or nonmaskable interrupt input port
P6.0	75	I/O	P6.0	95	I/O	General-purpose digital I/O
P6.1	76	I/O	P6.1	96	I/O	General-purpose digital I/O
P6.2	77	I/O	P6.2	97	I/O	General-purpose digital I/O
AV <sub>SS</sub>	78		AV <sub>SS</sub>	98		Analog supply voltage, negative terminal. Supplies SVS, brownout, oscillator, comparator_A, port 1, and LCD resistive divider circuitry.
DV <sub>SS1</sub>	79		DV <sub>SS1</sub>	99		Digital supply voltage, negative terminal.
AV <sub>CC</sub>	80		AV <sub>CC</sub>	100		Analog supply voltage, positive terminal. Supplies SVS, brownout, oscillator, comparator_A, port 1, and LCD resistive divider circuitry; must not power up prior to DV <sub>CC1</sub> /DV <sub>CC2</sub> .

# MSP430x43x1, MSP430x43x, MSP430x44x1, MSP430x44x MIXED SIGNAL MICROCONTROLLER

SLAS344G – JANUARY 2002 – REVISED OCTOBER 2009

## MSP430x43x Terminal Functions

TERMINAL						DESCRIPTION
PN NAME	NO.	I/O	PZ NAME	NO.	I/O	
DV <sub>CC1</sub>	1		DV <sub>CC1</sub>	1		Digital supply voltage, positive terminal.
P6.3/A3	2	I/O	P6.3/A3	2	I/O	General-purpose digital I/O / analog input a3—12-bit ADC
P6.4/A4	3	I/O	P6.4/A4	3	I/O	General-purpose digital I/O / analog input a4—12-bit ADC
P6.5/A5	4	I/O	P6.5/A5	4	I/O	General-purpose digital I/O / analog input a5—12-bit ADC
P6.6/A6	5	I/O	P6.6/A6	5	I/O	General-purpose digital I/O / analog input a6—12-bit ADC
P6.7/A7/SVSIN	6	I/O	P6.7/A7/SVSIN	6	I/O	General-purpose digital I/O / analog input a7—12-bit ADC, analog / input to brownout, supply voltage supervisor
V <sub>REF+</sub>	7	O	V <sub>REF+</sub>	7	O	Output of positive terminal of the reference voltage in the ADC
XIN	8	I	XIN	8	I	Input port for crystal oscillator XT1. Standard or watch crystals can be connected.
XOUT	9	O	XOUT	9	O	Output terminal of crystal oscillator XT1
V <sub>REF+</sub>	10	I	V <sub>REF+</sub>	10	I	Input for an external reference voltage to the ADC
V <sub>REF-</sub> /V <sub>REF-</sub>	11	I	V <sub>REF-</sub> /V <sub>REF-</sub>	11	I	Negative terminal for the ADC's reference voltage for both sources, the internal reference voltage, or an external applied reference voltage.
P5.1/S0	12	I/O	P5.1/S0	12	I/O	General-purpose digital I/O / LCD segment output 0
P5.0/S1	13	I/O	P5.0/S1	13	I/O	General-purpose digital I/O / LCD segment output 1
P4.7/S2	14	I/O	S2	14	O	General-purpose digital I/O / LCD segment output 2
P4.6/S3	15	I/O	S3	15	O	General-purpose digital I/O / LCD segment output 3
P4.5/S4	16	I/O	S4	16	O	General-purpose digital I/O / LCD segment output 4
P4.4/S5	17	I/O	S5	17	O	General-purpose digital I/O / LCD segment output 5
P4.3/S6	18	I/O	S6	18	O	General-purpose digital I/O / LCD segment output 6
P4.2/S7	19	I/O	S7	19	O	General-purpose digital I/O / LCD segment output 7
P4.1/S8	20	I/O	S8	20	O	General-purpose digital I/O / LCD segment output 8
P4.0/S9	21	I/O	S9	21	O	General-purpose digital I/O / LCD segment output 9
S10	22	O	S10	22	O	LCD segment output 10
S11	23	O	S11	23	O	LCD segment output 11
S12	24	O	S12	24	O	LCD segment output 12
S13	25	O	S13	25	O	LCD segment output 13
S14	26	O	S14	26	O	LCD segment output 14
S15	27	O	S15	27	O	LCD segment output 15
S16	28	O	S16	28	O	LCD segment output 16
S17	29	O	S17	29	O	LCD segment output 17
P2.7/ADC12CLK/ S18	30	I/O	S18	30	O	General-purpose digital I/O / conversion clock—12-bit ADC / LCD segment output 18
P2.6/CAOUT/S19	31	I/O	S19	31	O	General-purpose digital I/O / Comparator_A output / LCD segment output 19
S20	32	O	S20	32	O	LCD segment output 20
S21	33	O	S21	33	O	LCD segment output 21
S22	34	O	S22	34	O	LCD segment output 22
S23	35	O	S23	35	O	LCD segment output 23
P3.7/S24	36	I/O	S24	36	O	General-purpose digital I/O / LCD segment output 24
P3.6/S25	37	I/O	S25	37	O	General-purpose digital I/O / LCD segment output 25
P3.5/S26	38	I/O	S26	38	O	General-purpose digital I/O / LCD segment output 26
P3.4/S27	39	I/O	S27	39	O	General-purpose digital I/O / LCD segment output 27



# MSP430x43x1, MSP430x43x, MSP430x44x1, MSP430x44x MIXED SIGNAL MICROCONTROLLER

SLAS344G – JANUARY 2002 – REVISED OCTOBER 2009

## MSP430x43x Terminal Functions (Continued)

TERMINAL					DESCRIPTION	
PN NAME	NO.	I/O	PZ NAME	NO.		I/O
P3.3/UCLK0/S28	40	I/O	S28	40	O	General-purpose digital I/O / ext. clock i/p—USART0/UART or SPI mode, clock o/p—USART0/SPI mode / LCD segment output 28
P3.2/SOMI0/S29	41	I/O	S29	41	O	General-purpose digital I/O / slave out/master in of USART0/SPI mode / LCD segment output 29
P3.1/SIMO0/S30	42	I/O	S30	42	O	General-purpose digital I/O / slave out/master out of USART0/SPI mode / LCD segment output 30
P3.0/STE0/S31	43	I/O	S31	43	O	General-purpose digital I/O / slave transmit enable-USART0/SPI mode / LCD segment output 31
			S32	44	O	LCD segment output 32
			S33	45	O	LCD segment output 33
			P4.7/S34	46	I/O	General-purpose digital I/O / LCD segment output 34
			P4.6/S35	47	I/O	General-purpose digital I/O / LCD segment output 35
			P4.5/S36	48	I/O	General-purpose digital I/O / LCD segment output 36
			P4.4/S37	49	I/O	General-purpose digital I/O / LCD segment output 37
			P4.3/S38	50	I/O	General-purpose digital I/O / LCD segment output 38
			P4.2/S39	51	I/O	General-purpose digital I/O / LCD segment output 39
COM0	44	O	COM0	52	O	COM0–3 are used for LCD backplanes.
P5.2/COM1	45	I/O	P5.2/COM1	53	I/O	General-purpose digital I/O / common output, COM0–3 are used for LCD backplanes.
P5.3/COM2	46	I/O	P5.3/COM2	54	I/O	General-purpose digital I/O / common output, COM0–3 are used for LCD backplanes.
P5.4/COM3	47	I/O	P5.4/COM3	55	I/O	General-purpose digital I/O / common output, COM0–3 are used for LCD backplanes.
R03	48	I	R03	56	I	Input port of fourth positive (lowest) analog LCD level (V5)
P5.5/R13	49	I/O	P5.5/R13	57	I/O	General-purpose digital I/O / input port of third most positive analog LCD level (V4 or V3)
P5.6/R23	50	I/O	P5.6/R23	58	I/O	General-purpose digital I/O / input port of second most positive analog LCD level (V2)
P5.7/R33	51	I/O	P5.7/R33	59	I/O	General-purpose digital I/O / output port of most positive analog LCD level (V1)
DV <sub>CC2</sub>	52		DV <sub>CC2</sub>	60		Digital supply voltage, positive terminal.
DV <sub>SS2</sub>	53		DV <sub>SS2</sub>	61		Digital supply voltage, negative terminal.
			P4.1	62	I/O	General-purpose digital I/O
			P4.0	63	I/O	General-purpose digital I/O
			P3.7	64	I/O	General-purpose digital I/O
			P3.6	65	I/O	General-purpose digital I/O
			P3.5	66	I/O	General-purpose digital I/O
			P3.4	67	I/O	General-purpose digital I/O
			P3.3/UCLK0	68	I/O	General-purpose digital I/O / external clock input—USART0/UART or SPI mode, clock output—USART0/SPI mode
			P3.2/SOMI0	69	I/O	General-purpose digital I/O / slave out/master in of USART0/SPI mode
			P3.1/SIMO0	70	I/O	General-purpose digital I/O / slave in/master out of USART0/SPI mode
			P3.0/STE0	71	I/O	General-purpose digital I/O / slave transmit enable USART0/SPI mode
			P2.7/ADC12CLK	72	I/O	General-purpose digital I/O / conversion clock—12-bit ADC
			P2.6/CAOUT	73	I/O	General-purpose digital I/O / Comparator_A output
P2.5/URXD0	54	I/O	P2.5/URXD0	74	I/O	General-purpose digital I/O / receive data in—USART0/UART mode



# MSP430x43x1, MSP430x43x, MSP430x44x1, MSP430x44x MIXED SIGNAL MICROCONTROLLER

SLAS344G – JANUARY 2002 – REVISED OCTOBER 2009

## MSP430x43x Terminal Functions (Continued)

TERMINAL					DESCRIPTION	
PN NAME	NO.	I/O	PZ NAME	NO.		I/O
P2.4/UTXD0	55	I/O	P2.4/UTXD0	75	I/O	General-purpose digital I/O / transmit data out—USART0/UART mode
P2.3/TB2	56	I/O	P2.3/TB2	76	I/O	General-purpose digital I/O / Timer_B3 CCR2. Capture: CCI2A/CCI2B input, compare: Out2 output
P2.2/TB1	57	I/O	P2.2/TB1	77	I/O	General-purpose digital I/O / Timer_B3 CCR1. Capture: CCI1A/CCI1B input, compare: Out1 output
P2.1/TB0	58	I/O	P2.1/TB0	78	I/O	General-purpose digital I/O / Timer_B3 CCR0. Capture: CCI0A/CCI0B input, compare: Out0 output
P2.0/TA2	59	I/O	P2.0/TA2	79	I/O	General-purpose digital I/O / Timer_A Capture: CCI2A input, compare: Out2 output
P1.7/CA1	60	I/O	P1.7/CA1	80	I/O	General-purpose digital I/O / Comparator_A input
P1.6/CA0	61	I/O	P1.6/CA0	81	I/O	General-purpose digital I/O / Comparator_A input
P1.5/TACLK/ ACLK	62	I/O	P1.5/TACLK/ ACLK	82	I/O	General-purpose digital I/O / Timer_A, clock signal TACLK input / ACLK output (divided by 1, 2, 4, or 8)
P1.4/TBCLK/ SMCLK	63	I/O	P1.4/TBCLK/ SMCLK	83	I/O	General-purpose digital I/O / input clock TBCLK—Timer_B3 / submain system clock SMCLK output
P1.3/TBOUTH/ SVSOUT	64	I/O	P1.3/TBOUTH/ SVSOUT	84	I/O	General-purpose digital I/O / switch all PWM digital output ports to high impedance—Timer_B3 TB0 to TB2 / SVS: output of SVS comparator
P1.2/TA1	65	I/O	P1.2/TA1	85	I/O	General-purpose digital I/O / Timer_A, Capture: CCI1A input, compare: Out1 output
P1.1/TA0/MCLK	66	I/O	P1.1/TA0/MCLK	86	I/O	General-purpose digital I/O / Timer_A. Capture: CCI0B input / MCLK output. Note: TA0 is only an input on this pin / BSL receive
P1.0/TA0	67	I/O	P1.0/TA0	87	I/O	General-purpose digital I/O / Timer_A. Capture: CCI0A input, compare: Out0 output / BSL transmit
XT2OUT	68	O	XT2OUT	88	O	Output terminal of crystal oscillator XT2
XT2IN	69	I	XT2IN	89	I	Input port for crystal oscillator XT2. Only standard crystals can be connected.
TDO/TDI	70	I/O	TDO/TDI	90	I/O	Test data output port. TDO/TDI data output or programming data input terminal
TDI/TCLK	71	I	TDI/TCLK	91	I	Test data input or test clock input. The device protection fuse is connected to TDI/TCLK.
TMS	72	I	TMS	92	I	Test mode select. TMS is used as an input port for device programming and test.
TCK	73	I	TCK	93	I	Test clock. TCK is the clock input port for device programming and test.
RST/NMI	74	I	RST/NMI	94	I	General-purpose digital I/O / reset input or nonmaskable interrupt input port
P6.0/A0	75	I/O	P6.0/A0	95	I/O	General-purpose digital I/O / analog input a0 – 12-bit ADC
P6.1/A1	76	I/O	P6.1/A1	96	I/O	General-purpose digital I/O / analog input a1 – 12-bit ADC
P6.2/A2	77	I/O	P6.2/A2	97	I/O	General-purpose digital I/O / analog input a2 – 12-bit ADC
AV <sub>SS</sub>	78		AV <sub>SS</sub>	98		Analog supply voltage, negative terminal. Supplies SVS, brownout, oscillator, comparator_A, ADC12, port 1, and LCD resistive divider circuitry.
DV <sub>SS1</sub>	79		DV <sub>SS1</sub>	99		Digital supply voltage, negative terminal.
AV <sub>CC</sub>	80		AV <sub>CC</sub>	100		Analog supply voltage, positive terminal. Supplies SVS, brownout, oscillator, comparator_A, ADC12, port 1, and LCD resistive divider circuitry; must not power up prior to DV <sub>CC1</sub> /DV <sub>CC2</sub> .



# MSP430x43x1, MSP430x43x, MSP430x44x1, MSP430x44x MIXED SIGNAL MICROCONTROLLER

SLAS344G – JANUARY 2002 – REVISED OCTOBER 2009

## MSP430x44x1 Terminal Functions

TERMINAL NAME	NO.	I/O	DESCRIPTION
DV <sub>CC1</sub>	1		Digital supply voltage, positive terminal.
P6.3	2	I/O	General-purpose digital I/O
P6.4	3	I/O	General-purpose digital I/O
P6.5	4	I/O	General-purpose digital I/O
P6.6	5	I/O	General-purpose digital I/O
P6.7/SVSIN	6	I/O	General-purpose digital I/O / analog input to brownout, supply voltage supervisor
Reserved	7	O	Reserved, do not connect externally
XIN	8	I	Input port for crystal oscillator XT1. Standard or watch crystals can be connected.
XOUT	9	O	Output terminal of crystal oscillator XT1
DV <sub>SS</sub>	10	I	Connect to DV <sub>SS</sub>
DV <sub>SS</sub>	11	I	Connect to DV <sub>SS</sub>
P5.1/S0	12	I/O	General-purpose digital I/O / LCD segment output 0
P5.0/S1	13	I/O	General-purpose digital I/O / LCD segment output 1
S2	14	O	LCD segment output 2
S3	15	O	LCD segment output 3
S4	16	O	LCD segment output 4
S5	17	O	LCD segment output 5
S6	18	O	LCD segment output 6
S7	19	O	LCD segment output 7
S8	20	O	LCD segment output 8
S9	21	O	LCD segment output 9
S10	22	O	LCD segment output 10
S11	23	O	LCD segment output 11
S12	24	O	LCD segment output 12
S13	25	O	LCD segment output 13
S14	26	O	LCD segment output 14
S15	27	O	LCD segment output 15
S16	28	O	LCD segment output 16
S17	29	O	LCD segment output 17
S18	30	O	LCD segment output 18
S19	31	O	LCD segment output 19
S20	32	O	LCD segment output 20
S21	33	O	LCD segment output 21
S22	34	O	LCD segment output 22
S23	35	O	LCD segment output 23
S24	36	O	LCD segment output 24
S25	37	O	LCD segment output 25
S26	38	O	LCD segment output 26
S27	39	O	LCD segment output 27
S28	40	O	LCD segment output 28



# MSP430x43x1, MSP430x43x, MSP430x44x1, MSP430x44x MIXED SIGNAL MICROCONTROLLER

SLAS344G – JANUARY 2002 – REVISED OCTOBER 2009

## MSP430x44x1 Terminal Functions (Continued)

TERMINAL		I/O	DESCRIPTION
PN NAME	NO.		
S29	41	O	LCD segment output 29
S30	42	O	LCD segment output 30
S31	43	O	LCD segment output 31
S32	44	O	LCD segment output 32
S33	45	O	LCD segment output 33
P4.7/S34	46	I/O	General-purpose digital I/O / LCD segment output 34
P4.6/S35	47	I/O	General-purpose digital I/O / LCD segment output 35
P4.5/UCLK1/S36	48	I/O	General-purpose digital I/O / external clock input—USART1/UART or SPI mode, clock output—USART1/SPI MODE / LCD segment output 36
P4.4/SOMI1/S37	49	I/O	General-purpose digital I/O / slave out/master in of USART1/SPI mode / LCD segment output 37
P4.3/SIMO1/S38	50	I/O	General-purpose digital I/O / slave in/master out of USART1/SPI mode / LCD segment output 38
P4.2/STE1/S39	51	I/O	General-purpose digital I/O / slave transmit enable—USART1/SPI mode / LCD segment output 39
COM0	52	O	COM0–3 are used for LCD backplanes.
P5.2/COM1	53	I/O	General-purpose digital I/O / common output, COM0–3 are used for LCD backplanes.
P5.3/COM2	54	I/O	General-purpose digital I/O / common output, COM0–3 are used for LCD backplanes.
P5.4/COM3	55	I/O	General-purpose digital I/O / common output, COM0–3 are used for LCD backplanes.
R03	56	I	Input port of fourth positive (lowest) analog LCD level (V5)
P5.5/R13	57	I/O	General-purpose digital I/O / Input port of third most positive analog LCD level (V4 or V3)
P5.6/R23	58	I/O	General-purpose digital I/O / Input port of second most positive analog LCD level (V2)
P5.7/R33	59	I/O	General-purpose digital I/O / Output port of most positive analog LCD level (V1)
DV <sub>CC2</sub>	60		Digital supply voltage, positive terminal.
DV <sub>SS2</sub>	61		Digital supply voltage, negative terminal.
P4.1/URXD1	62	I/O	General-purpose digital I/O / receive data in—USART1/UART mode
P4.0/UTXD1	63	I/O	General-purpose digital I/O / transmit data out—USART1/UART mode
P3.7/TB6	64	I/O	General-purpose digital I/O / Timer_B7 CCR6 / Capture: CCI6A/CCI6B input, compare: Out6 output
P3.6/TB5	65	I/O	General-purpose digital I/O / Timer_B7 CCR5 / Capture: CCI5A/CCI5B input, compare: Out5 output
P3.5/TB4	66	I/O	General-purpose digital I/O / Timer_B7 CCR4 / Capture: CCI4A/CCI4B input, compare: Out4 output
P3.4/TB3	67	I/O	General-purpose digital I/O / Timer_B7 CCR3 / Capture: CCI3A/CCI3B input, compare: Out3 output
P3.3/UCLK0	68	I/O	General-purpose digital I/O / external clock input—USART0/UART or SPI mode, clock output—USART0/SPI mode
P3.2/SOMI0	69	I/O	General-purpose digital I/O / slave out/master in of USART0/SPI mode
P3.1/SIMO0	70	I/O	General-purpose digital I/O / slave in/master out of USART0/SPI mode
P3.0/STE0	71	I/O	General-purpose digital I/O / slave transmit enable—USART0/SPI mode
P2.7	72	I/O	General-purpose digital I/O
P2.6/CAOUT	73	I/O	General-purpose digital I/O / Comparator_A output
P2.5/URXD0	74	I/O	General-purpose digital I/O / receive data in—USART0/UART mode
P2.4/UTXD0	75	I/O	General-purpose digital I/O / transmit data out—USART0/UART mode
P2.3/TB2	76	I/O	General-purpose digital I/O / Timer_B7 CCR2. Capture: CCI2A/CCI2B input, compare: Out2 output
P2.2/TB1	77	I/O	General-purpose digital I/O / Timer_B7 CCR1. Capture: CCI1A/CCI1B input, compare: Out1 output
P2.1/TB0	78	I/O	General-purpose digital I/O / Timer_B7 CCR0. Capture: CCI0A/CCI0B input, compare: Out0 output
P2.0/TA2	79	I/O	General-purpose digital I/O / Timer_A Capture: CCI2A input, compare: Out2 output
P1.7/CA1	80	I/O	General-purpose digital I/O / Comparator_A input



# MSP430x43x1, MSP430x43x, MSP430x44x1, MSP430x44x MIXED SIGNAL MICROCONTROLLER

SLAS344G – JANUARY 2002 – REVISED OCTOBER 2009

## MSP430x44x1 Terminal Functions (Continued)

TERMINAL		I/O	DESCRIPTION
PN NAME	NO.		
P1.6/CA0	81	I/O	General-purpose digital I/O / Comparator_A input
P1.5/TACLK/ ACLK	82	I/O	General-purpose digital I/O / Timer_A, clock signal TACLK input / ACLK output (divided by 1, 2, 4, or 8)
P1.4/TBCLK/ SMCLK	83	I/O	General-purpose digital I/O / input clock TBCLK—Timer_B7 / submain system clock SMCLK output
P1.3/TBOUTH/ SVSOUT	84	I/O	General-purpose digital I/O / switch all PWM digital output ports to high impedance—Timer_B7 TB0 to TB6 / SVS: output of SVS comparator
P1.2/TA1	85	I/O	General-purpose digital I/O / Timer_A, Capture: CCI1A input, compare: Out1 output
P1.1/TA0/MCLK	86	I/O	General-purpose digital I/O / Timer_A. Capture: CCI0B input / MCLK output. Note: TA0 is only an input on this pin / BSL receive
P1.0/TA0	87	I/O	General-purpose digital I/O / Timer_A. Capture: CCI0A input, compare: Out0 output / BSL transmit
XT2OUT	88	O	Output terminal of crystal oscillator XT2
XT2IN	89	I	Input port for crystal oscillator XT2. Only standard crystals can be connected.
TDO/TDI	90	I/O	Test data output port. TDO/TDI data output or programming data input terminal
TDI/TCLK	91	I	Test data input or test clock input. The device protection fuse is connected to TDI/TCLK.
TMS	92	I	Test mode select. TMS is used as an input port for device programming and test.
TCK	93	I	Test clock. TCK is the clock input port for device programming and test.
RST/NMI	94	I	Reset input or nonmaskable interrupt input port
P6.0	95	I/O	General-purpose digital I/O
P6.1	96	I/O	General-purpose digital I/O
P6.2	97	I/O	General-purpose digital I/O
AV <sub>SS</sub>	98		Analog supply voltage, negative terminal. Supplies SVS, brownout, oscillator, comparator_A, port 1, and LCD resistive divider circuitry.
DV <sub>SS1</sub>	99		Digital supply voltage, negative terminal.
AV <sub>CC</sub>	100		Analog supply voltage, positive terminal. Supplies SVS, brownout, oscillator, comparator_A, port 1, and LCD resistive divider circuitry; must not power up prior to DV <sub>CC1</sub> /DV <sub>CC2</sub> .



# MSP430x43x1, MSP430x43x, MSP430x44x1, MSP430x44x MIXED SIGNAL MICROCONTROLLER

SLAS344G – JANUARY 2002 – REVISED OCTOBER 2009

## MSP430x44x Terminal Functions

TERMINAL NAME	NO.	I/O	DESCRIPTION
DV <sub>CC1</sub>	1		Digital supply voltage, positive terminal.
P6.3/A3	2	I/O	General-purpose digital I/O / analog input a3—12-bit ADC
P6.4/A4	3	I/O	General-purpose digital I/O / analog input a4—12-bit ADC
P6.5/A5	4	I/O	General-purpose digital I/O / analog input a5—12-bit ADC
P6.6/A6	5	I/O	General-purpose digital I/O / analog input a6—12-bit ADC
P6.7/A7/SVSIN	6	I/O	General-purpose digital I/O / analog input a7—12-bit ADC / analog input to brownout, supply voltage supervisor
V <sub>REF+</sub>	7	O	Output of positive terminal of the reference voltage in the ADC
XIN	8	I	Input port for crystal oscillator XT1. Standard or watch crystals can be connected.
XOUT	9	O	Output terminal of crystal oscillator XT1
V <sub>REF+</sub>	10	I	Input for an external reference voltage to the ADC
V <sub>REF-</sub> /V <sub>REF-</sub>	11	I	Negative terminal for the ADC's reference voltage for both sources, the internal reference voltage, or an external applied reference voltage
P5.1/S0	12	I/O	General-purpose digital I/O / LCD segment output 0
P5.0/S1	13	I/O	General-purpose digital I/O / LCD segment output 1
S2	14	O	LCD segment output 2
S3	15	O	LCD segment output 3
S4	16	O	LCD segment output 4
S5	17	O	LCD segment output 5
S6	18	O	LCD segment output 6
S7	19	O	LCD segment output 7
S8	20	O	LCD segment output 8
S9	21	O	LCD segment output 9
S10	22	O	LCD segment output 10
S11	23	O	LCD segment output 11
S12	24	O	LCD segment output 12
S13	25	O	LCD segment output 13
S14	26	O	LCD segment output 14
S15	27	O	LCD segment output 15
S16	28	O	LCD segment output 16
S17	29	O	LCD segment output 17
S18	30	O	LCD segment output 18
S19	31	O	LCD segment output 19
S20	32	O	LCD segment output 20
S21	33	O	LCD segment output 21
S22	34	O	LCD segment output 22
S23	35	O	LCD segment output 23
S24	36	O	LCD segment output 24
S25	37	O	LCD segment output 25
S26	38	O	LCD segment output 26
S27	39	O	LCD segment output 27
S28	40	O	LCD segment output 28



# MSP430x43x1, MSP430x43x, MSP430x44x1, MSP430x44x MIXED SIGNAL MICROCONTROLLER

SLAS344G – JANUARY 2002 – REVISED OCTOBER 2009

## MSP430x44x Terminal Functions (Continued)

TERMINAL		I/O	DESCRIPTION
PN NAME	NO.		
S29	41	O	LCD segment output 29
S30	42	O	LCD segment output 30
S31	43	O	LCD segment output 31
S32	44	O	LCD segment output 32
S33	45	O	LCD segment output 33
P4.7/S34	46	I/O	General-purpose digital I/O / LCD segment output 34
P4.6/S35	47	I/O	General-purpose digital I/O / LCD segment output 35
P4.5/UCLK1/S36	48	I/O	General-purpose digital I/O / external clock input—USART1/UART or SPI mode, clock output—USART1/SPI MODE / LCD segment output 36
P4.4/SOMI1/S37	49	I/O	General-purpose digital I/O / slave out/master in of USART1/SPI mode / LCD segment output 37
P4.3/SIMO1/S38	50	I/O	General-purpose digital I/O / slave in/master out of USART1/SPI mode / LCD segment output 38
P4.2/STE1/S39	51	I/O	General-purpose digital I/O / slave transmit enable—USART1/SPI mode / LCD segment output 39
COM0	52	O	COM0–3 are used for LCD backplanes.
P5.2/COM1	53	I/O	General-purpose digital I/O / common output, COM0–3 are used for LCD backplanes.
P5.3/COM2	54	I/O	General-purpose digital I/O / common output, COM0–3 are used for LCD backplanes.
P5.4/COM3	55	I/O	General-purpose digital I/O / common output, COM0–3 are used for LCD backplanes.
R03	56	I	Input port of fourth positive (lowest) analog LCD level (V5)
P5.5/R13	57	I/O	General-purpose digital I/O / Input port of third most positive analog LCD level (V4 or V3)
P5.6/R23	58	I/O	General-purpose digital I/O / Input port of second most positive analog LCD level (V2)
P5.7/R33	59	I/O	General-purpose digital I/O / Output port of most positive analog LCD level (V1)
DV <sub>CC2</sub>	60		Digital supply voltage, positive terminal.
DV <sub>SS2</sub>	61		Digital supply voltage, negative terminal.
P4.1/URXD1	62	I/O	General-purpose digital I/O / receive data in—USART1/UART mode
P4.0/UTXD1	63	I/O	General-purpose digital I/O / transmit data out—USART1/UART mode
P3.7/TB6	64	I/O	General-purpose digital I/O / Timer_B7 CCR6 / Capture: CCI6A/CCI6B input, compare: Out6 output
P3.6/TB5	65	I/O	General-purpose digital I/O / Timer_B7 CCR5 / Capture: CCI5A/CCI5B input, compare: Out5 output
P3.5/TB4	66	I/O	General-purpose digital I/O / Timer_B7 CCR4 / Capture: CCI4A/CCI4B input, compare: Out4 output
P3.4/TB3	67	I/O	General-purpose digital I/O / Timer_B7 CCR3 / Capture: CCI3A/CCI3B input, compare: Out3 output
P3.3/UCLK0	68	I/O	General-purpose digital I/O / external clock input—USART0/UART or SPI mode, clock output—USART0/SPI mode
P3.2/SOMI0	69	I/O	General-purpose digital I/O / slave out/master in of USART0/SPI mode
P3.1/SIMO0	70	I/O	General-purpose digital I/O / slave in/master out of USART0/SPI mode
P3.0/STE0	71	I/O	General-purpose digital I/O / slave transmit enable—USART0/SPI mode
P2.7/ADC12CLK	72	I/O	General-purpose digital I/O / conversion clock—12-bit ADC
P2.6/CAOUT	73	I/O	General-purpose digital I/O / Comparator_A output
P2.5/URXD0	74	I/O	General-purpose digital I/O / receive data in—USART0/UART mode
P2.4/UTXD0	75	I/O	General-purpose digital I/O / transmit data out—USART0/UART mode
P2.3/TB2	76	I/O	General-purpose digital I/O / Timer_B7 CCR2. Capture: CCI2A/CCI2B input, compare: Out2 output
P2.2/TB1	77	I/O	General-purpose digital I/O / Timer_B7 CCR1. Capture: CCI1A/CCI1B input, compare: Out1 output
P2.1/TB0	78	I/O	General-purpose digital I/O / Timer_B7 CCR0. Capture: CCI0A/CCI0B input, compare: Out0 output
P2.0/TA2	79	I/O	General-purpose digital I/O / Timer_A Capture: CCI2A input, compare: Out2 output
P1.7/CA1	80	I/O	General-purpose digital I/O / Comparator_A input



# MSP430x43x1, MSP430x43x, MSP430x44x1, MSP430x44x MIXED SIGNAL MICROCONTROLLER

SLAS344G – JANUARY 2002 – REVISED OCTOBER 2009

## MSP430x44x Terminal Functions (Continued)

TERMINAL		I/O	DESCRIPTION
PN NAME	NO.		
P1.6/CA0	81	I/O	General-purpose digital I/O / Comparator_A input
P1.5/TACLK/ ACLK	82	I/O	General-purpose digital I/O / Timer_A, clock signal TACLK input / ACLK output (divided by 1, 2, 4, or 8)
P1.4/TBCLK/ SMCLK	83	I/O	General-purpose digital I/O / input clock TBCLK—Timer_B7 / submain system clock SMCLK output
P1.3/TBOUTH/ SVSOUT	84	I/O	General-purpose digital I/O / switch all PWM digital output ports to high impedance—Timer_B7 TB0 to TB6 / SVS: output of SVS comparator
P1.2/TA1	85	I/O	General-purpose digital I/O / Timer_A, Capture: CCI1A input, compare: Out1 output
P1.1/TA0/MCLK	86	I/O	General-purpose digital I/O / Timer_A, Capture: CCI0B input / MCLK output. Note: TA0 is only an input on this pin / BSL receive
P1.0/TA0	87	I/O	General-purpose digital I/O / Timer_A, Capture: CCI0A input, compare: Out0 output / BSL transmit
XT2OUT	88	O	Output terminal of crystal oscillator XT2
XT2IN	89	I	Input port for crystal oscillator XT2. Only standard crystals can be connected.
TDO/TDI	90	I/O	Test data output port. TDO/TDI data output or programming data input terminal
TDI/TCLK	91	I	Test data input or test clock input. The device protection fuse is connected to TDI/TCLK.
TMS	92	I	Test mode select. TMS is used as an input port for device programming and test.
TCK	93	I	Test clock. TCK is the clock input port for device programming and test.
RST/NMI	94	I	Reset input or nonmaskable interrupt input port
P6.0/A0	95	I/O	General-purpose digital I/O, analog input a0—12-bit ADC
P6.1/A1	96	I/O	General-purpose digital I/O, analog input a1—12-bit ADC
P6.2/A2	97	I/O	General-purpose digital I/O, analog input a2—12-bit ADC
AV <sub>SS</sub>	98		Analog supply voltage, negative terminal. Supplies SVS, brownout, oscillator, comparator_A, ADC12, port 1, and LCD resistive divider circuitry.
DV <sub>SS1</sub>	99		Digital supply voltage, negative terminal.
AV <sub>CC</sub>	100		Analog supply voltage, positive terminal. Supplies SVS, brownout, oscillator, comparator_A, ADC12, port 1, and LCD resistive divider circuitry; must not power up prior to DV <sub>CC1</sub> /DV <sub>CC2</sub> .



## short-form description

### CPU

The MSP430 CPU has a 16-bit RISC architecture that is highly transparent to the application. All operations, other than program-flow instructions, are performed as register operations in conjunction with seven addressing modes for source operand and four addressing modes for destination operand.

The CPU is integrated with 16 registers that provide reduced instruction execution time. The register-to-register operation execution time is one cycle of the CPU clock.

Four of the registers, R0 to R3, are dedicated as program counter, stack pointer, status register, and constant generator respectively. The remaining registers are general-purpose registers.

Peripherals are connected to the CPU using data, address, and control buses, and can be handled with all instructions.

Program Counter	PC/R0
Stack Pointer	SP/R1
Status Register	SR/CG1/R2
Constant Generator	CG2/R3
General-Purpose Register	R4
General-Purpose Register	R5
General-Purpose Register	R6
General-Purpose Register	R7
General-Purpose Register	R8
General-Purpose Register	R9
General-Purpose Register	R10
General-Purpose Register	R11
General-Purpose Register	R12
General-Purpose Register	R13
General-Purpose Register	R14
General-Purpose Register	R15

### instruction set

The instruction set consists of 51 instructions with three formats and seven address modes. Each instruction can operate on word and byte data. Table 1 shows examples of the three types of instruction formats; Table 2 shows the address modes.

**Table 1. Instruction Word Formats**

Dual operands, source-destination	e.g. ADD R4,R5	R4 + R5 ----> R5
Single operands, destination only	e.g. CALL R8	PC -->(TOS), R8--> PC
Relative jump, un/conditional	e.g. JNE	Jump-on-equal bit = 0

**Table 2. Address Mode Descriptions**

ADDRESS MODE	S	D	SYNTAX	EXAMPLE	OPERATION
Register	●	●	MOV Rs,Rd	MOV R10,R11	R10 --> R11
Indexed	●	●	MOV X(Rn),Y(Rm)	MOV 2(R5),6(R6)	M(2+R5)--> M(6+R6)
Symbolic (PC relative)	●	●	MOV EDE,TONI		M(EDE) --> M(TONI)
Absolute	●	●	MOV &MEM,&TCDAT		M(MEM) --> M(TCDAT)
Indirect	●		MOV @Rn,Y(Rm)	MOV @R10,Tab(R6)	M(R10) --> M(Tab+R6)
Indirect autoincrement	●		MOV @Rn+,Rm	MOV @R10+,R11	M(R10) --> R11 R10 + 2--> R10
Immediate	●		MOV #X,TONI	MOV #45,TONI	#45 --> M(TONI)

NOTE: S = source    D = destination

# MSP430x43x1, MSP430x43x, MSP430x44x1, MSP430x44x MIXED SIGNAL MICROCONTROLLER

SLAS344G – JANUARY 2002 – REVISED OCTOBER 2009

---

## operating modes

The MSP430 has one active mode and five software selectable low-power modes of operation. An interrupt event can wake up the device from any of the five low-power modes, service the request and restore back to the low-power mode on return from the interrupt program.

The following six operating modes can be configured by software:

- Active mode (AM)
  - All clocks are active
- Low-power mode 0 (LPM0)
  - CPU is disabled
  - ACLK and SMCLK remain active, MCLK is disabled
  - FLL+ loop control remains active
- Low-power mode 1 (LPM1)
  - CPU is disabled
  - FLL+ loop control is disabled
  - ACLK and SMCLK remain active, MCLK is disabled
- Low-power mode 2 (LPM2)
  - CPU is disabled
  - MCLK, FLL+ loop control, and DCOCLK are disabled
  - DCO's dc generator remains enabled
  - ACLK remains active
- Low-power mode 3 (LPM3)
  - CPU is disabled
  - MCLK, FLL+ loop control, and DCOCLK are disabled
  - DCO's dc generator is disabled
  - ACLK remains active
- Low-power mode 4 (LPM4)
  - CPU is disabled
  - ACLK is disabled
  - MCLK, FLL+ loop control, and DCOCLK are disabled
  - DCO's dc generator is disabled
  - Crystal oscillator is stopped



# MSP430x43x1, MSP430x43x, MSP430x44x1, MSP430x44x MIXED SIGNAL MICROCONTROLLER

SLAS344G – JANUARY 2002 – REVISED OCTOBER 2009

## interrupt vector addresses

The interrupt vectors and the power-up starting address are located in the address range 0FFFFh to 0FFE0h. The vector contains the 16-bit address of the appropriate interrupt-handler instruction sequence.

**Table 3. Interrupt Sources, Flags, and Vectors**

INTERRUPT SOURCE	INTERRUPT FLAG	SYSTEM INTERRUPT	WORD ADDRESS	PRIORITY
Power-Up External Reset Watchdog Flash Memory	WDTIFG KEYV (see Note 1)	Reset	0FFFEh	15, highest
NMI Oscillator Fault Flash Memory Access Violation	NMIIFG (see Notes 1 and 3) OFIFG (see Notes 1 and 3) ACCIFG (see Notes 1 and 3)	(Non)maskable (Non)maskable (Non)maskable	0FFFCh	14
Timer_B7 <sup>†</sup>	TBCCR0 CCIFG (see Note 2)	Maskable	0FFFAh	13
Timer_B7 <sup>†</sup>	TBCCR1 to TBCCR6 CCIFGs TBIFG (see Notes 1 and 2)	Maskable	0FFF8h	12
Comparator_A	CAIFG	Maskable	0FFF6h	11
Watchdog Timer	WDTIFG	Maskable	0FFF4h	10
USART0 Receive	URXIFG0	Maskable	0FFF2h	9
USART0 Transmit	UTXIFG0	Maskable	0FFF0h	8
ADC12 (see Note 4)	ADC12IFG (see Notes 1 and 2)	Maskable	0FFEEh	7
Timer_A3	TACCR0 CCIFG (see Note 2)	Maskable	0FFECh	6
Timer_A3	TACCR1 and TACCR2 CCIFGs, TAIFG (see Notes 1 and 2)	Maskable	0FFEAh	5
I/O Port P1 (Eight Flags)	P1IFG.0 to P1IFG.7 (see Notes 1 and 2)	Maskable	0FFE8h	4
USART1 Receive <sup>‡</sup>	URXIFG1	Maskable	0FFE6h	3
USART1 Transmit <sup>‡</sup>	UTXIFG1	Maskable	0FFE4h	2
I/O Port P2 (Eight Flags)	P2IFG.0 to P2IFG.7 (see Notes 1 and 2)	Maskable	0FFE2h	1
Basic Timer1	BTIFG	Maskable	0FFE0h	0, lowest

<sup>†</sup> '43x(1) uses Timer\_B3 with TBCCR0, 1 and 2 CCIFG flags, and TBIFG. '44x(1) uses Timer\_B7 with TBCCR0 CCIFG, TBCCR1 to TBCCR6 CCIFGs, and TBIFG

<sup>‡</sup> USART1 is implemented in '44x(1) only.

- NOTES:
- Multiple source flags
  - Interrupt flags are located in the module.
  - (Non)maskable: the individual interrupt-enable bit can disable an interrupt event, but the general-interrupt enable can not disable it.
  - ADC12 is not implemented in MSP430x43x1 and MSP430x44x1 devices.

# MSP430x43x1, MSP430x43x, MSP430x44x1, MSP430x44x MIXED SIGNAL MICROCONTROLLER

SLAS344G – JANUARY 2002 – REVISED OCTOBER 2009

## special function registers

Most interrupt and module-enable bits are collected in the lowest address space. Special-function register bits not allocated to a functional purpose are not physically present in the device. This arrangement provides simple software access.

### interrupt enable 1 and 2

Address	7	6	5	4	3	2	1	0
0h	UTXIE0	URXIE0	ACCVIE	NMIIE			OFIE	WDTIE
	rw-0	rw-0	rw-0	rw-0			rw-0	rw-0

WDTIE: Watchdog-timer interrupt enable. Inactive if watchdog mode is selected. Active if watchdog timer is configured in interval timer mode.

OFIE: Oscillator-fault-interrupt enable

NMIIE: Nonmaskable-interrupt enable

ACCVIE: Flash access violation interrupt enable

URXIE0: USART0: UART and SPI receive-interrupt enable

UTXIE0: USART0: UART and SPI transmit-interrupt enable

Address	7	6	5	4	3	2	1	0
01h	BTIE		UTXIE1	URXIE1				
	rw-0		rw-0	rw-0				

URXIE1: USART1: UART and SPI receive-interrupt enable (MSP430F44x(1) devices only)

UTXIE1: USART1: UART and SPI transmit-interrupt enable (MSP430F44x(1) devices only)

BTIE: Basic timer interrupt enable

### interrupt flag register 1 and 2

Address	7	6	5	4	3	2	1	0
02h	UTXIFG0	URXIFG0		NMIIFG			OFIFG	WDTIFG
	rw-1	rw-0		rw-0			rw-1	rw-(0)

WDTIFG: Set on watchdog timer overflow (in watchdog mode) or security key violation. Reset on  $V_{CC}$  power up or a reset condition at the  $\overline{RST}/NMI$  pin in reset mode.

OFIFG: Flag set on oscillator fault

NMIIFG: Set via  $\overline{RST}/NMI$  pin

URXIFG0: USART0: UART and SPI receive flag

UTXIFG0: USART0: UART and SPI transmit flag

Address	7	6	5	4	3	2	1	0
03h	BTIFG		UTXIFG1	URXIFG1				
	rw		rw-1	rw-0				

URXIFG1: USART1: UART and SPI receive flag (MSP430F44x(1) devices only)

UTXIFG1: USART1: UART and SPI transmit flag (MSP430F44x(1) devices only)

BTIFG: Basic timer flag



# MSP430x43x1, MSP430x43x, MSP430x44x1, MSP430x44x MIXED SIGNAL MICROCONTROLLER

SLAS344G – JANUARY 2002 – REVISED OCTOBER 2009

## module enable registers 1 and 2

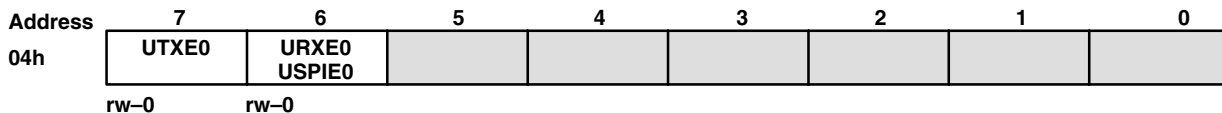

URXE0: USART0: UART mode receive enable  
 UTXE0: USART0: UART mode transmit enable  
 USPIE0: USART0: SPI mode transmit and receive enable

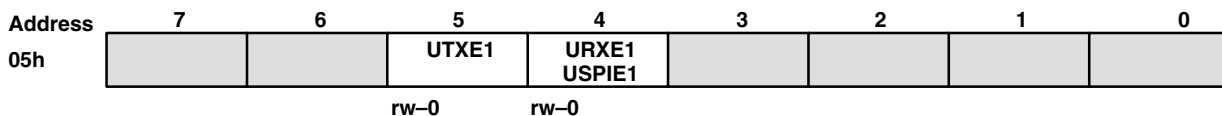

URXE1: USART1: UART mode receive enable (MSP430F44x(1) devices only)  
 UTXE1: USART1: UART mode transmit enable (MSP430F44x(1) devices only)  
 USPIE1: USART1: SPI mode transmit and receive enable (MSP430F44x(1) devices only)

**Legend:** rw: Bit Can Be Read and Written  
 rw-0,1: Bit Can Be Read and Written. It Is Reset or Set by PUC.  
 rw-(0,1): Bit Can Be Read and Written. It Is Reset or Set by POR.  
 SFR Bit Not Present in Device

## memory organization

		MSP430F435 MSP430F4351	MSP430F436 MSP430F4361	MSP430F437 MSP430F4371 MSP430F447	MSP430F448 MSP430F4481	MSP430F449 MSP430F4491
Memory	Size	16KB	24KB	32KB	48KB	60KB
Main: interrupt vector	Flash	0FFFFh – 0FFE0h	0FFFFh – 0FFE0h	0FFFFh – 0FFE0h	0FFFFh – 0FFE0h	0FFFFh – 0FFE0h
Main: code memory	Flash	0FFFFh – 0C000h	0FFFFh – 0A000h	0FFFFh – 08000h	0FFFFh – 04000h	0FFFFh – 01100h
Information memory	Size	256 Byte	256 Byte	256 Byte	256 Byte	256 Byte
	Flash	010FFh – 01000h	010FFh – 01000h	010FFh – 01000h	010FFh – 01000h	010FFh – 01000h
Boot memory	Size	1KB	1KB	1KB	1KB	1KB
	ROM	0FFFh – 0C00h	0FFFh – 0C00h	0FFFh – 0C00h	0FFFh – 0C00h	0FFFh – 0C00h
RAM	Size	512 Byte	1KB	1KB	2KB	2KB
		03FFh – 0200h	05FFh – 0200h	05FFh – 0200h	09FFh – 0200h	09FFh – 0200h
Peripherals	16-bit	01FFh – 0100h	01FFh – 0100h	01FFh – 0100h	01FFh – 0100h	01FFh – 0100h
	8-bit	0FFh – 010h	0FFh – 010h	0FFh – 010h	0FFh – 010h	0FFh – 010h
	8-bit SFR	0Fh – 00h	0Fh – 00h	0Fh – 00h	0Fh – 00h	0Fh – 00h

## bootstrap loader (BSL)

The MSP430 bootstrap loader (BSL) enables users to program the flash memory or RAM using a UART serial interface. Access to the MSP430 memory via the BSL is protected by user-defined password. For complete description of the features of the BSL and its implementation, see the *MSP430 Memory Programming User's Guide*, literature number SLAU265.

BSL Function	PN Package Pins	PZ Package Pins
Data Transmit	67 - P1.0	87 - P1.0
Data Receive	66 - P1.1	86 - P1.1



# MSP430x43x1, MSP430x43x, MSP430x44x1, MSP430x44x MIXED SIGNAL MICROCONTROLLER

SLAS344G – JANUARY 2002 – REVISED OCTOBER 2009

## flash memory

The flash memory can be programmed via the JTAG port, the bootstrap loader, or in-system by the CPU. The CPU can perform single-byte and single-word writes to the flash memory. Features of the flash memory include:

- Flash memory has n segments of main memory and two segments of information memory (A and B) of 128 bytes each. Each segment in main memory is 512 bytes in size.
- Segments 0 to n may be erased in one step, or each segment may be individually erased.
- Segments A and B can be erased individually, or as a group with segments 0 to n. Segments A and B are also called *information memory*.
- New devices may have some bytes programmed in the information memory (needed for test during manufacturing). The user should perform an erase of the information memory prior to the first use.

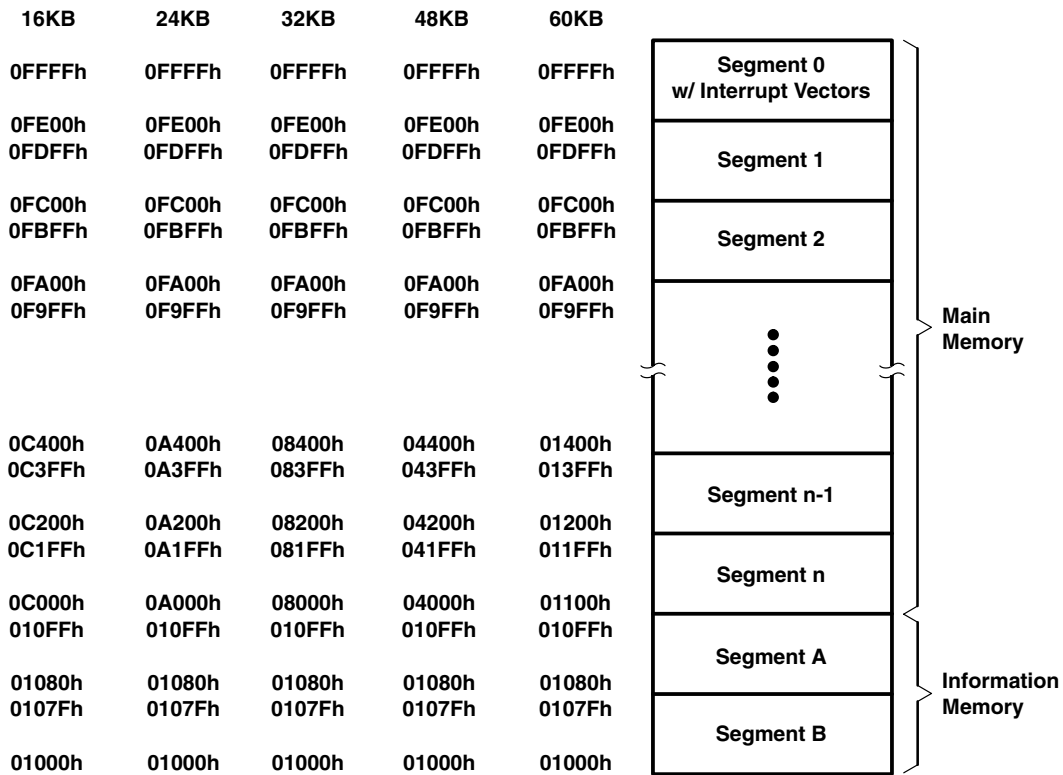

## peripherals

Peripherals are connected to the CPU through data, address, and control buses and can be handled using all instructions. For complete module descriptions, see the *MSP430x4xx Family User's Guide*, literature number SLAU056.

## digital I/O

There are six 8-bit I/O ports implemented—ports P1 through P6:

- All individual I/O bits are independently programmable.
- Any combination of input, output, and interrupt conditions is possible.
- Edge-selectable interrupt input capability for all the eight bits of ports P1 and P2.
- Read/write access to port-control registers is supported by all instructions.

## oscillator and system clock

The clock system in the MSP430x43x(1) and MSP43x44x(1) family of devices is supported by the FLL+ module, which includes support for a 32768-Hz watch crystal oscillator, an internal digitally controlled oscillator (DCO), and a high-frequency crystal oscillator. The FLL+ clock module is designed to meet the requirements of both low system cost and low power consumption. The FLL+ features a digital frequency-locked loop (FLL) hardware that, in conjunction with a digital modulator, stabilizes the DCO frequency to a programmable multiple of the watch crystal frequency. The internal DCO provides a fast turn-on clock source and stabilizes in less than 6  $\mu$ s. The FLL+ module provides the following clock signals:

- Auxiliary clock (ACLK), sourced from a 32768-Hz watch crystal or a high-frequency crystal
- Main clock (MCLK), the system clock used by the CPU
- Sub-Main clock (SMCLK), the sub-system clock used by the peripheral modules
- ACLK/n, the buffered output of ACLK, ACLK/2, ACLK/4, or ACLK/8

## brownout, supply voltage supervisor (SVS)

The brownout circuit is implemented to provide the proper internal reset signal to the device during power on and power off. The supply voltage supervisor (SVS) circuitry detects if the supply voltage drops below a user selectable level and supports both supply voltage supervision (the device is automatically reset) and supply voltage monitoring (SVM, the device is not automatically reset).

The CPU begins code execution after the brownout circuit releases the device reset. However,  $V_{CC}$  may not have ramped to  $V_{CC(\min)}$  at that time. The user must insure the default FLL+ settings are not changed until  $V_{CC}$  reaches  $V_{CC(\min)}$ . If desired, the SVS circuit can be used to determine when  $V_{CC}$  reaches  $V_{CC(\min)}$ .

## hardware multiplier (MSP430x44x(1) only)

The multiplication operation is supported by a dedicated peripheral module. The module performs  $16 \times 16$ ,  $16 \times 8$ ,  $8 \times 16$ , and  $8 \times 8$  bit operations. The module is capable of supporting signed and unsigned multiplication as well as signed and unsigned multiply and accumulate operations. The result of an operation can be accessed immediately after the operands have been loaded into the peripheral registers. No additional clock cycles are required.

## watchdog timer (WDT)

The primary function of the watchdog timer (WDT) module is to perform a controlled system restart after a software problem occurs. If the selected time interval expires, a system reset is generated. If the watchdog function is not needed in an application, the module can be configured as an interval timer and can generate interrupts at selected time intervals.

# MSP430x43x1, MSP430x43x, MSP430x44x1, MSP430x44x MIXED SIGNAL MICROCONTROLLER

SLAS344G – JANUARY 2002 – REVISED OCTOBER 2009

## USART0

The MSP430x43x(1) and the MSP430x44x(1) have one hardware universal synchronous/asynchronous receive transmit (USART0) peripheral module that is used for serial data communication. The USART supports synchronous SPI (3 or 4 pin) and asynchronous UART communication protocols, using double-buffered transmit and receive channels.

## USART1 (MSP430x44x(1) only)

The MSP430x44x(1) has a second hardware universal synchronous/asynchronous receive transmit (USART1) peripheral module that is used for serial data communication. The USART supports synchronous SPI (3 or 4 pin) and asynchronous UART communication protocols, using double-buffered transmit and receive channels. Operation of USART1 is identical to USART0.

## Timer\_A3

Timer\_A3 is a 16-bit timer/counter with three capture/compare registers. Timer\_A3 can support multiple capture/compares, PWM outputs, and interval timing. Timer\_A3 also has extensive interrupt capabilities. Interrupts may be generated from the counter on overflow conditions and from each of the capture/compare registers.

TIMER_A3 SIGNAL CONNECTIONS							
INPUT PIN NUMBER		DEVICE INPUT SIGNAL	MODULE INPUT NAME	MODULE BLOCK	MODULE OUTPUT SIGNAL	OUTPUT PIN NUMBER	
PN	PZ					PN	PZ
62 - P1.5	82 - P1.5	TACLK	TACLK	Timer	NA		
		ACLK	ACLK				
		SMCLK	SMCLK				
62 - P1.5	82 - P1.5	TACLK	INCLK				
67 - P1.0	87 - P1.0	TA0	CCI0A	CCR0	TA0	67 - P1.0	87 - P1.0
66 - P1.1	86 - P1.1	TA0	CCI0B				
		DV <sub>SS</sub>	GND				
		DV <sub>CC</sub>	V <sub>CC</sub>				
65 - P1.2	85 - P1.2	TA1	CCI1A	CCR1	TA1	14 - P1.2	85 - P1.2
		CAOUT (internal)	CCI1B			ADC12 (internal) <sup>‡</sup>	
		DV <sub>SS</sub>	GND				
		DV <sub>CC</sub>	V <sub>CC</sub>				
59 - P2.0	79 - P2.0	TA2	CCI2A	CCR2	TA2	15 - P1.3	79 - P2.0
		ACLK (internal)	CCI2B				
		DV <sub>SS</sub>	GND				
		DV <sub>CC</sub>	V <sub>CC</sub>				

<sup>‡</sup> Not implemented in MSP430x43x1 and MSP430x44x1 devices.

## Timer\_B3 (MSP430x43x(1) only)

Timer\_B3 is a 16-bit timer/counter with three capture/compare registers. Timer\_B3 can support multiple capture/compares, PWM outputs, and interval timing. Timer\_B3 also has extensive interrupt capabilities. Interrupts may be generated from the counter on overflow conditions and from each of the capture/compare registers.



# MSP430x43x1, MSP430x43x, MSP430x44x1, MSP430x44x MIXED SIGNAL MICROCONTROLLER

SLAS344G – JANUARY 2002 – REVISED OCTOBER 2009

## Timer\_B7 (MSP430x44x(1) only)

Timer\_B7 is a 16-bit timer/counter with seven capture/compare registers. Timer\_B7 can support multiple capture/compares, PWM outputs, and interval timing. Timer\_B7 also has extensive interrupt capabilities. Interrupts may be generated from the counter on overflow conditions and from each of the capture/compare registers.

TIMER_B3/B7 SIGNAL CONNECTIONS†							
INPUT PIN NUMBER		DEVICE INPUT SIGNAL	MODULE INPUT NAME	MODULE BLOCK	MODULE OUTPUT SIGNAL	OUTPUT PIN NUMBER	
PN	PZ					PN	PZ
63 - P1.4	83 - P1.4	TBCLK	TBCLK	Timer	NA		
		ACLK	ACLK				
		SMCLK	SMCLK				
63 - P1.4	83 - P1.4	TBCLK	INCLK				
58 - P2.1	78 - P2.1	TB0	CCI0A	CCR0†	TB0	58 - P2.1	78 - P2.1
58 - P2.1	78 - P2.1	TB0	CCI0B				
		DV <sub>SS</sub>	GND				
		DV <sub>CC</sub>	V <sub>CC</sub>				
57 - P2.2	77 - P2.2	TB1	CCI1A	CCR1†	TB1	57 - P2.2	77 - P2.2
57 - P2.2	77 - P2.2	TB1	CCI1B				
		DV <sub>SS</sub>	GND				
		DV <sub>CC</sub>	V <sub>CC</sub>				
56 - P2.3	76 - P2.3	TB2	CCI2A	CCR2†	TB2	56 - P2.3	76 - P2.3
56 - P2.3	76 - P2.3	TB2	CCI2B				
		DV <sub>SS</sub>	GND				
		DV <sub>CC</sub>	V <sub>CC</sub>				
	67 - P3.4	TB3	CCI3A	CCR3	TB3		67 - P3.4
	67 - P3.4	TB3	CCI3B				
		DV <sub>SS</sub>	GND				
		DV <sub>CC</sub>	V <sub>CC</sub>				
	66 - P3.5	TB4	CCI4A	CCR4	TB4		66 - P3.5
	66 - P3.5	TB4	CCI4B				
		DV <sub>SS</sub>	GND				
		DV <sub>CC</sub>	V <sub>CC</sub>				
	65 - P3.6	TB5	CCI5A	CCR5	TB5		65 - P3.6
	65 - P3.6	TB5	CCI5B				
		DV <sub>SS</sub>	GND				
		DV <sub>CC</sub>	V <sub>CC</sub>				
	64 - P3.7	TB6	CCI6A	CCR6	TB6		64 - P3.7
		ACLK (internal)	CCI6B				
		DV <sub>SS</sub>	GND				
		DV <sub>CC</sub>	V <sub>CC</sub>				

† Timer\_B3 implements three capture/compare blocks (CCR0, CCR1 and CCR2 only).

‡ Not implemented in MSP430x43x1 and MSP430x44x1 devices.

# MSP430x43x1, MSP430x43x, MSP430x44x1, MSP430x44x MIXED SIGNAL MICROCONTROLLER

SLAS344G – JANUARY 2002 – REVISED OCTOBER 2009

---

## Comparator\_A

The primary function of the comparator\_A module is to support precision slope analog-to-digital conversions, battery-voltage supervision, and monitoring of external analog signals.

## ADC12 (not implemented in MSP430x43x1 and MSP430x44x1)

The ADC12 module supports fast, 12-bit analog-to-digital conversions. The module implements a 12-bit SAR core, sample select control, reference generator and a 16 word conversion-and-control buffer. The conversion-and-control buffer allows up to 16 independent ADC samples to be converted and stored without any CPU intervention.

## Basic Timer1

The Basic Timer1 has two independent 8-bit timers which can be cascaded to form a 16-bit timer/counter. Both timers can be read and written by software. The Basic Timer1 can be used to generate periodic interrupts and clock for the LCD module.

## LCD driver

The LCD driver generates the segment and common signals required to drive an LCD display. The LCD controller has dedicated data memory to hold segment drive information. Common and segment signals are generated as defined by the mode. Static, 2-MUX, 3-MUX, and 4-MUX LCDs are supported by this peripheral.



# MSP430x43x1, MSP430x43x, MSP430x44x1, MSP430x44x MIXED SIGNAL MICROCONTROLLER

SLAS344G – JANUARY 2002 – REVISED OCTOBER 2009

## peripheral file map

PERIPHERALS WITH WORD ACCESS			
<b>Watchdog</b>	Watchdog timer control	WDTCTL	0120h
<b>Timer_B7/ Timer_B3</b> (see Note 1)	Capture/compare register 6	TBCCR6	019Eh
	Capture/compare register 5	TBCCR5	019Ch
	Capture/compare register 4	TBCCR4	019Ah
	Capture/compare register 3	TBCCR3	0198h
	Capture/compare register 2	TBCCR2	0196h
	Capture/compare register 1	TBCCR1	0194h
	Capture/compare register 0	TBCCR0	0192h
	Timer_B register	TBR	0190h
	Capture/compare control 6	TBCCTL6	018Eh
	Capture/compare control 5	TBCCTL5	018Ch
	Capture/compare control 4	TBCCTL4	018Ah
	Capture/compare control 3	TBCCTL3	0188h
	Capture/compare control 2	TBCCTL2	0186h
	Capture/compare control 1	TBCCTL1	0184h
	Capture/compare control 0	TBCCTL0	0182h
	Timer_B control	TBCTL	0180h
	Timer_B interrupt vector	TBIV	011Eh
	<b>Timer_A3</b>	Reserved	
Reserved			017Ch
Reserved			017Ah
Reserved			0178h
Capture/compare register 2		TACCR2	0176h
Capture/compare register 1		TACCR1	0174h
Capture/compare register 0		TACCR0	0172h
Timer_A register		TAR	0170h
Reserved			016Eh
Reserved			016Ch
Reserved			016Ah
Reserved			0168h
Capture/compare control 2		TACCTL2	0166h
Capture/compare control 1		TACCTL1	0164h
Capture/compare control 0		TACCTL0	0162h
Timer_A control		TACTL	0160h
Timer_A interrupt vector	TAIV	012Eh	
<b>Hardware Multiplier</b> (MSP430x44x(1) only)	Sum extend	SUMEXT	013Eh
	Result high word	RESHI	013Ch
	Result low word	RESLO	013Ah
	Second operand	OP2	0138h
	Multiply signed + accumulate/operand1	MACS	0136h
	Multiply + accumulate/operand1	MAC	0134h
	Multiply signed/operand1	MPYS	0132h
	Multiply unsigned/operand1	MPY	0130h

NOTE 1: Timer\_B7 in the MSP430x44x(1) family has seven CCRs; Timer\_B3 in the MSP430x43x(1) family has three CCRs.



# MSP430x43x1, MSP430x43x, MSP430x44x1, MSP430x44x MIXED SIGNAL MICROCONTROLLER

SLAS344G – JANUARY 2002 – REVISED OCTOBER 2009

## peripheral file map (continued)

PERIPHERALS WITH WORD ACCESS (CONTINUED)			
<b>Flash</b>	Flash control 3	FCTL3	012Ch
	Flash control 2	FCTL2	012Ah
	Flash control 1	FCTL1	0128h
<b>ADC12</b> (not implemented in MSP430F43x1 and MSP430F44x1)	Conversion memory 15	ADC12MEM15	015Eh
	Conversion memory 14	ADC12MEM14	015Ch
	Conversion memory 13	ADC12MEM13	015Ah
	Conversion memory 12	ADC12MEM12	0158h
	Conversion memory 11	ADC12MEM11	0156h
	Conversion memory 10	ADC12MEM10	0154h
	Conversion memory 9	ADC12MEM9	0152h
	Conversion memory 8	ADC12MEM8	0150h
	Conversion memory 7	ADC12MEM7	014Eh
	Conversion memory 6	ADC12MEM6	014Ch
	Conversion memory 5	ADC12MEM5	014Ah
	Conversion memory 4	ADC12MEM4	0148h
	Conversion memory 3	ADC12MEM3	0146h
	Conversion memory 2	ADC12MEM2	0144h
	Conversion memory 1	ADC12MEM1	0142h
	Conversion memory 0	ADC12MEM0	0140h
	Interrupt-vector-word register	ADC12IV	01A8h
	Inerrupt-enable register	ADC12IE	01A6h
	Inerrupt-flag register	ADC12IFG	01A4h
	Control register 1	ADC12CTL1	01A2h
	Control register 0	ADC12CTL0	01A0h
	ADC memory-control register15	ADC12MCTL15	08Fh
	ADC memory-control register14	ADC12MCTL14	08Eh
	ADC memory-control register13	ADC12MCTL13	08Dh
	ADC memory-control register12	ADC12MCTL12	08Ch
	ADC memory-control register11	ADC12MCTL11	08Bh
	ADC memory-control register10	ADC12MCTL10	08Ah
	ADC memory-control register9	ADC12MCTL9	089h
	ADC memory-control register8	ADC12MCTL8	088h
	ADC memory-control register7	ADC12MCTL7	087h
	ADC memory-control register6	ADC12MCTL6	086h
	ADC memory-control register5	ADC12MCTL5	085h
	ADC memory-control register4	ADC12MCTL4	084h
ADC memory-control register3	ADC12MCTL3	083h	
ADC memory-control register2	ADC12MCTL2	082h	
ADC memory-control register1	ADC12MCTL1	081h	
ADC memory-control register0	ADC12MCTL0	080h	



# MSP430x43x1, MSP430x43x, MSP430x44x1, MSP430x44x MIXED SIGNAL MICROCONTROLLER

SLAS344G – JANUARY 2002 – REVISED OCTOBER 2009

## peripheral file map (continued)

PERIPHERALS WITH BYTE ACCESS			
<b>LCD</b>	LCD memory 20	LCDM20	0A4h
	:	:	:
	LCD memory 16	LCDM16	0A0h
	LCD memory 15	LCDM15	09Fh
	:	:	:
	LCD memory 1 LCD control and mode	LCDM1 LCDCTL	091h 090h
<b>USART1</b> (MSP430F44x(1) only)	Transmit buffer	U1TXBUF	07Fh
	Receive buffer	U1RXBUF	07Eh
	Baud rate	U1BR1	07Dh
	Baud rate	U1BR0	07Ch
	Modulation control	U1MCTL	07Bh
	Receive control	U1RCTL	07Ah
	Transmit control	U1TCTL	079h
	USART control	U1CTL	078h
<b>USART0</b>	Transmit buffer	U0TXBUF	077h
	Receive buffer	U0RXBUF	076h
	Baud rate	U0BR1	075h
	Baud rate	U0BR0	074h
	Modulation control	U0MCTL	073h
	Receive control	U0RCTL	072h
	Transmit control	U0TCTL	071h
	USART control	U0CTL	070h
<b>Comparator_A</b>	Comparator_A port disable	CAPD	05Bh
	Comparator_A control2	CACTL2	05Ah
	Comparator_A control1	CACTL1	059h
<b>BrownOUT, SVS</b>	SVS control register (Reset by brownout signal)	SVSCTL	056h
<b>FLL+ Clock</b>	FLL+ Control1	FLL_CTL1	054h
	FLL+ Control0	FLL_CTL0	053h
	System clock frequency control	SCFQCTL	052h
	System clock frequency integrator	SCFI1	051h
	System clock frequency integrator	SCFI0	050h
<b>Basic Timer1</b>	BT counter2	BTCNT2	047h
	BT counter1	BTCNT1	046h
	BT control	BTCTL	040h
<b>Port P6</b>	Port P6 selection	P6SEL	037h
	Port P6 direction	P6DIR	036h
	Port P6 output	P6OUT	035h
	Port P6 input	P6IN	034h
<b>Port P5</b>	Port P5 selection	P5SEL	033h
	Port P5 direction	P5DIR	032h
	Port P5 output	P5OUT	031h
	Port P5 input	P5IN	030h

# MSP430x43x1, MSP430x43x, MSP430x44x1, MSP430x44x MIXED SIGNAL MICROCONTROLLER

SLAS344G – JANUARY 2002 – REVISED OCTOBER 2009

## peripheral file map (continued)

PERIPHERALS WITH BYTE ACCESS (CONTINUED)			
<b>Port P4</b>	Port P4 selection	P4SEL	01Fh
	Port P4 direction	P4DIR	01Eh
	Port P4 output	P4OUT	01Dh
	Port P4 input	P4IN	01Ch
<b>Port P3</b>	Port P3 selection	P3SEL	01Bh
	Port P3 direction	P3DIR	01Ah
	Port P3 output	P3OUT	019h
	Port P3 input	P3IN	018h
<b>Port P2</b>	Port P2 selection	P2SEL	02Eh
	Port P2 interrupt enable	P2IE	02Dh
	Port P2 interrupt-edge select	P2IES	02Ch
	Port P2 interrupt flag	P2IFG	02Bh
	Port P2 direction	P2DIR	02Ah
	Port P2 output	P2OUT	029h
	Port P2 input	P2IN	028h
<b>Port P1</b>	Port P1 selection	P1SEL	026h
	Port P1 interrupt enable	P1IE	025h
	Port P1 interrupt-edge select	P1IES	024h
	Port P1 interrupt flag	P1IFG	023h
	Port P1 direction	P1DIR	022h
	Port P1 output	P1OUT	021h
	Port P1 input	P1IN	020h
<b>Special functions</b>	SFR module enable2	ME2	005h
	SFR module enable1	ME1	004h
	SFR interrupt flag2	IFG2	003h
	SFR interrupt flag1	IFG1	002h
	SFR interrupt enable2	IE2	001h
	SFR interrupt enable1	IE1	000h

## absolute maximum ratings over operating free-air temperature (unless otherwise noted)<sup>†</sup>

Voltage applied at $V_{CC}$ to $V_{SS}$ .....	-0.3 V to 4.1 V
Voltage applied to any pin (see Note) .....	-0.3 V to $V_{CC} + 0.3$ V
Diode current at any device terminal . . . . .	$\pm 2$ mA
Storage temperature, $T_{stg}$ : Unprogrammed device .....	-55°C to 150°C
Programmed device .....	-55°C to 85°C

<sup>†</sup> Stresses beyond those listed under “absolute maximum ratings” may cause permanent damage to the device. These are stress ratings only, and functional operation of the device at these or any other conditions beyond those indicated under “recommended operating conditions” is not implied. Exposure to absolute-maximum-rated conditions for extended periods may affect device reliability.

NOTE: All voltages referenced to  $V_{SS}$ . The JTAG fuse-blow voltage,  $V_{FB}$ , is allowed to exceed the absolute maximum rating. The voltage is applied to the TDI/TCLK pin when blowing the JTAG fuse.



# MSP430x43x1, MSP430x43x, MSP430x44x1, MSP430x44x MIXED SIGNAL MICROCONTROLLER

SLAS344G – JANUARY 2002 – REVISED OCTOBER 2009

## recommended operating conditions

		MIN	NOM	MAX	UNIT	
Supply voltage during program execution $V_{CC}$ ( $AV_{CC} = DV_{CC1} = DV_{CC2} = V_{CC}$ ) (see Note 1)		1.8		3.6	V	
Supply voltage during program execution, SVS enabled, PORON=1 (see Note 1 and Note 2) $V_{CC}$ ( $AV_{CC} = DV_{CC1} = DV_{CC2} = V_{CC}$ )		2		3.6	V	
Supply voltage during flash memory programming $V_{CC}$ ( $AV_{CC} = DV_{CC1} = DV_{CC2} = V_{CC}$ ) (see Note 1)		2.7		3.6	V	
Supply voltage, $V_{SS}$ ( $AV_{SS} = DV_{SS1} = DV_{SS2} = V_{SS}$ )		0		0	V	
Operating free-air temperature range, $T_A$		-40		85	°C	
LFXT1 crystal frequency, $f_{(LFXT1)}$ (see Note 3)	LF selected, XTS_FLL=0	Watch crystal		32.768	kHz	
	XT1 selected, XTS_FLL=1	Ceramic resonator		450	8000	kHz
	XT1 selected, XTS_FLL=1	Crystal		1000	8000	kHz
XT2 crystal frequency, $f_{(XT2)}$	Ceramic resonator		450	8000	kHz	
	Crystal		1000	8000		
Processor frequency (signal MCLK), $f_{(System)}$	$V_{CC} = 1.8$ V		DC	4.15	MHz	
	$V_{CC} = 3.6$ V		DC	8		

- NOTES:
1. It is recommended to power  $AV_{CC}$  and  $DV_{CC}$  from the same source. A maximum difference of 0.3 V between  $AV_{CC}$  and  $DV_{CC}$  can be tolerated during power up and operation.
  2. The minimum operating supply voltage is defined according to the trip point where POR is going active by decreasing the supply voltage. POR is going inactive when the supply voltage is raised above the minimum supply voltage plus the hysteresis of the SVS circuitry.
  3. In LF mode, the LFXT1 oscillator requires a watch crystal. In XT1 mode, LFXT1 accepts a ceramic resonator or a crystal.

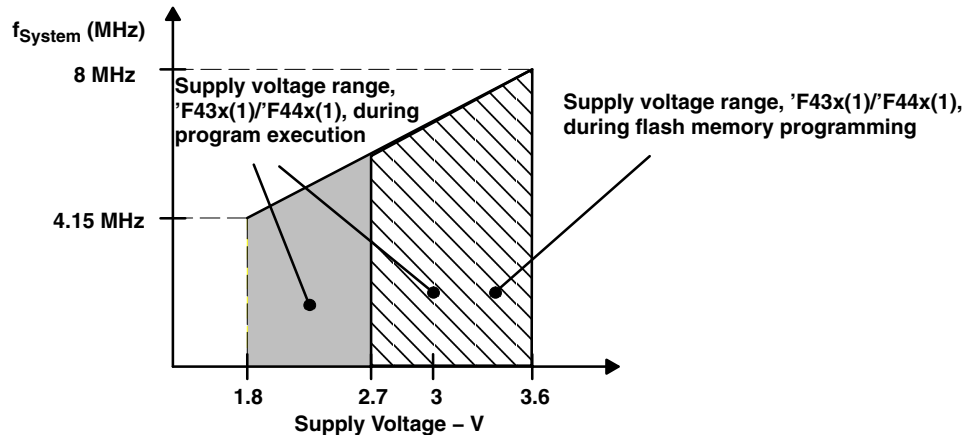

Figure 1. Frequency vs Supply Voltage, MSP430F43x(1) or MSP430F44x(1)

# MSP430x43x1, MSP430x43x, MSP430x44x1, MSP430x44x MIXED SIGNAL MICROCONTROLLER

SLAS344G – JANUARY 2002 – REVISED OCTOBER 2009

## electrical characteristics over recommended operating free-air temperature (unless otherwise noted)

### supply current into $V_{CC}$ + $DV_{CC}$ excluding external current

PARAMETER		TEST CONDITIONS	$V_{CC}$	MIN	TYP	MAX	UNIT	
$I_{(AM)}$	Active mode (see Note 1), $f_{(MCLK)} = f_{(SMCLK)} = 1$ MHz, $f_{(ACLK)} = 32768$ Hz XTS_FLL=0, SELM=(0,1)	$T_A = -40^{\circ}\text{C}$ to $85^{\circ}\text{C}$	2.2 V	280	350		$\mu\text{A}$	
			3 V	420	560			
$I_{(LPM0)}$	Low-power mode, (LPM0) (see Note 1 and Note 4)	$T_A = -40^{\circ}\text{C}$ to $85^{\circ}\text{C}$	2.2 V	32	45		$\mu\text{A}$	
			3 V	55	70			
$I_{(LPM2)}$	Low-power mode, (LPM2), $f_{(MCLK)} = f_{(SMCLK)} = 0$ MHz, $f_{(ACLK)} = 32768$ Hz, SCG0 = 0 (see Note 2 and Note 4)	$T_A = -40^{\circ}\text{C}$ to $85^{\circ}\text{C}$	2.2 V	11	14		$\mu\text{A}$	
			3 V	17	22			
$I_{(LPM3)}$	Low-power mode, (LPM3) $f_{(MCLK)} = f_{(SMCLK)} = 0$ MHz, $f_{(ACLK)} = 32,768$ Hz, SCG0 = 1 (see Note 3 and Note 4)	$T_A = -40^{\circ}\text{C}$	2.2 V	1	1.5		$\mu\text{A}$	
				$T_A = 25^{\circ}\text{C}$	1.1	1.5		
				$T_A = 60^{\circ}\text{C}$	2	3		
				$T_A = 85^{\circ}\text{C}$	3.5	6		
		$T_A = -40^{\circ}\text{C}$	3 V	1.8	2.2		$\mu\text{A}$	
				$T_A = 25^{\circ}\text{C}$	1.6	1.9		
				$T_A = 60^{\circ}\text{C}$	2.5	3.5		
				$T_A = 85^{\circ}\text{C}$	4.2	7.5		
$I_{(LPM4)}$	Low-power mode, (LPM4) $f_{(MCLK)} = 0$ MHz, $f_{(SMCLK)} = 0$ MHz, $f_{(ACLK)} = 0$ Hz, SCG0 = 1 (see Note 2 and Note 4)	$T_A = -40^{\circ}\text{C}$	2.2 V	0.1	0.5		$\mu\text{A}$	
				$T_A = 25^{\circ}\text{C}$	0.1	0.5		
				$T_A = 60^{\circ}\text{C}$	0.7	1.1		
				$T_A = 85^{\circ}\text{C}$	1.7	3		
		$T_A = -40^{\circ}\text{C}$	3 V	0.1	0.5		$\mu\text{A}$	
				$T_A = 25^{\circ}\text{C}$	0.1	0.5		
				$T_A = 60^{\circ}\text{C}$	0.8	1.2		
				$T_A = 85^{\circ}\text{C}$	1.9	3.5		

- NOTES: 1. Timer\_B is clocked by  $f_{(DCOCLK)} = f_{(DCO)} = 1$  MHz. All inputs are tied to 0 V or to  $V_{CC}$ . Outputs do not source or sink any current.  
 2. All inputs are tied to 0 V or to  $V_{CC}$ . Outputs do not source or sink any current.  
 3. All inputs are tied to 0 V or to  $V_{CC}$ . Outputs do not source or sink any current. The current consumption in LPM3 is measured with active Basic Timer1 and LCD (ACLK selected). The current consumption of the Comparator\_A and the SVS module are specified in the respective sections. The LPM3 currents are characterized with a KDS Daishinku DT-38 (6 pF) crystal and OSCCAPx=1h.  
 4. Current consumption for brownout included.

### Current consumption of active mode versus system frequency

$$I_{(AM)} = I_{(AM)} [1 \text{ MHz}] \times f_{(\text{System})} [\text{MHz}]$$

### Current consumption of active mode versus supply voltage

$$I_{(AM)} = I_{(AM)} [3 \text{ V}] + 175 \mu\text{A/V} \times (V_{CC} - 3 \text{ V})$$



# MSP430x43x1, MSP430x43x, MSP430x44x1, MSP430x44x MIXED SIGNAL MICROCONTROLLER

SLAS344G – JANUARY 2002 – REVISED OCTOBER 2009

electrical characteristics over recommended operating free-air temperature (unless otherwise noted) (continued)

## Schmitt-trigger inputs – ports P1, P2, P3, P4, P5, P6

PARAMETER		V <sub>CC</sub>	MIN	TYP	MAX	UNIT
V <sub>IT+</sub>	Positive-going input threshold voltage	2.2 V	1.1		1.5	V
		3 V	1.5		1.9	
V <sub>IT-</sub>	Negative-going input threshold voltage	2.2 V	0.4		0.9	V
		3 V	0.9		1.3	
V <sub>hys</sub>	Input voltage hysteresis (V <sub>IT+</sub> – V <sub>IT-</sub> )	2.2 V	0.3		1.1	V
		3 V	0.5		1	

## standard inputs – $\overline{\text{RST}}/\text{NMI}$ , JTAG (TCK, TMS, TDI/TCLK)

PARAMETER		V <sub>CC</sub>	MIN	TYP	MAX	UNIT
V <sub>IL</sub>	Low-level input voltage	2.2 V / 3 V	V <sub>SS</sub>		V <sub>SS</sub> +0.6	V
V <sub>IH</sub>	High-level input voltage		0.8×V <sub>CC</sub>		V <sub>CC</sub>	V

## inputs P<sub>x.x</sub>, T<sub>Ax</sub>, T<sub>Bx</sub>

PARAMETER		TEST CONDITIONS	V <sub>CC</sub>	MIN	TYP	MAX	UNIT
t <sub>(int)</sub>	External interrupt timing	Port P1, P2: P1.x to P2.x, external trigger signal for the interrupt flag, (see Note 1)	2.2 V/3 V	1.5			cycle
			2.2 V	62			ns
			3 V	50			
t <sub>(cap)</sub>	Timer_A, Timer_B capture timing	TA0, TA1, TA2	2.2 V	62			ns
		TB0, TB1, TB2, TB3, TB4, TB5, TB6 (see Note 2)	3 V	50			
f <sub>(TAext)</sub>	Timer_A, Timer_B clock frequency externally applied to pin	TACLK, TBCLK, INCLK: t <sub>(H)</sub> = t <sub>(L)</sub>	2.2 V			8	MHz
f <sub>(TBext)</sub>			3 V			10	
f <sub>(TAint)</sub>	Timer_A, Timer_B clock frequency	SMCLK or ACLK signal selected	2.2 V			8	MHz
f <sub>(TBint)</sub>			3 V			10	

- NOTES: 1. The external signal sets the interrupt flag every time the minimum t<sub>(int)</sub> cycle and time parameters are met. It may be set even with trigger signals shorter than t<sub>(int)</sub>. Both the cycle and timing specifications must be met to ensure the flag is set. t<sub>(int)</sub> is measured in MCLK cycles.
2. Seven capture/compare registers in 'x44x(1) and three capture/compare registers in 'x43x(1).

## leakage current (see Notes 1 and 2)

PARAMETER		TEST CONDITIONS		V <sub>CC</sub>	MIN	TYP	MAX	UNIT
I <sub>lkg</sub> (P1.x)	Leakage current	Port P1	Port 1: V <sub>(P1.x)</sub>	2.2 V/3 V			±50	nA
I <sub>lkg</sub> (P2.x)		Port P2	Port 2: V <sub>(P2.x)</sub>				±50	
I <sub>lkg</sub> (P3.x)		Port P3	Port 3: V <sub>(P3.x)</sub>				±50	
I <sub>lkg</sub> (P4.x)		Port P4	Port 4: V <sub>(P4.x)</sub>				±50	
I <sub>lkg</sub> (P5.x)		Port P5	Port 5: V <sub>(P5.x)</sub>				±50	
I <sub>lkg</sub> (P6.x)		Port P6	Port 6: V <sub>(P6.x)</sub>				±50	

- NOTES: 1. The leakage current is measured with V<sub>SS</sub> or V<sub>CC</sub> applied to the corresponding pin(s), unless otherwise noted.
2. The port pin must be selected as input and there must be no optional pullup or pulldown resistor.



# MSP430x43x1, MSP430x43x, MSP430x44x1, MSP430x44x MIXED SIGNAL MICROCONTROLLER

SLAS344G – JANUARY 2002 – REVISED OCTOBER 2009

## electrical characteristics over recommended operating free-air temperature (unless otherwise noted) (continued)

### outputs – ports P1, P2, P3, P4, P5, P6

PARAMETER		TEST CONDITIONS	V <sub>CC</sub>	MIN	TYP	MAX	UNIT
V <sub>OH</sub>	High-level output voltage	I <sub>OH(max)</sub> = -1.5 mA (See Note 1)	2.2 V	V <sub>CC</sub> -0.25		V <sub>CC</sub>	V
		I <sub>OH(max)</sub> = -6 mA (See Note 2)	2.2 V	V <sub>CC</sub> -0.6		V <sub>CC</sub>	
		I <sub>OH(max)</sub> = -1.5 mA (See Note 1)	3 V	V <sub>CC</sub> -0.25		V <sub>CC</sub>	
		I <sub>OH(max)</sub> = -6 mA (See Note 2)	3 V	V <sub>CC</sub> -0.6		V <sub>CC</sub>	
V <sub>OL</sub>	Low-level output voltage	I <sub>OL(max)</sub> = 1.5 mA (See Note 1)	2.2 V	V <sub>SS</sub>		V <sub>SS</sub> +0.25	V
		I <sub>OL(max)</sub> = 6 mA (See Note 2)	2.2 V	V <sub>SS</sub>		V <sub>SS</sub> +0.6	
		I <sub>OL(max)</sub> = 1.5 mA (See Note 1)	3 V	V <sub>SS</sub>		V <sub>SS</sub> +0.25	
		I <sub>OL(max)</sub> = 6 mA (See Note 2)	3 V	V <sub>SS</sub>		V <sub>SS</sub> +0.6	

- NOTES: 1. The maximum total current, I<sub>OH(max)</sub> and I<sub>OL(max)</sub>, for all outputs combined, should not exceed ±12 mA to satisfy the maximum specified voltage drop.  
 2. The maximum total current, I<sub>OH(max)</sub> and I<sub>OL(max)</sub>, for all outputs combined, should not exceed ±48 mA to satisfy the maximum specified voltage drop.

### output frequency

PARAMETER		TEST CONDITIONS	MIN	TYP	MAX	UNIT
f <sub>(Px,y)</sub>	(1 ≤ x ≤ 6, 0 ≤ y ≤ 7)	C <sub>L</sub> = 20 pF, I <sub>L</sub> = ±1.5 mA	V <sub>CC</sub> = 2.2 V	DC	5	MHz
			V <sub>CC</sub> = 3 V	DC	7.5	
f <sub>(ACLK)</sub>	P1.1/TA0/MCLK, P1.5/TACLK/ACLK P1.4/TBCLK/SMCLK	C <sub>L</sub> = 20 pF			f <sub>(System)</sub>	MHz
f <sub>(MCLK)</sub>						
f <sub>(SMCLK)</sub>						
t <sub>(Xdc)</sub>	Duty cycle of output frequency	P1.5/TACLK/ACLK, C <sub>L</sub> = 20 pF V <sub>CC</sub> = 2.2 V / 3 V	f <sub>(ACLK)</sub> = f <sub>(LFXT1)</sub> = f <sub>(XT1)</sub>	40%	60%	
			f <sub>(ACLK)</sub> = f <sub>(LFXT1)</sub> = f <sub>(LF)</sub>	30%	70%	
			f <sub>(ACLK)</sub> = f <sub>(LFXT1)</sub>	50%		
		P1.1/TA0/MCLK, C <sub>L</sub> = 20 pF, V <sub>CC</sub> = 2.2 V / 3 V	f <sub>(MCLK)</sub> = f <sub>(XT1)</sub>	40%	60%	
			f <sub>(MCLK)</sub> = f <sub>(DCOCLK)</sub>	50%– 15 ns	50%	50%+ 15 ns
		P1.4/TBCLK/SMCLK, C <sub>L</sub> = 20 pF, V <sub>CC</sub> = 2.2 V / 3 V	f <sub>(SMCLK)</sub> = f <sub>(XT2)</sub>	40%	60%	
f <sub>(SMCLK)</sub> = f <sub>(DCOCLK)</sub>	50%– 15 ns		50%	50%+ 15 ns		



electrical characteristics over recommended operating free-air temperature (unless otherwise noted) (continued)

outputs – Ports P1, P2, P3, P4, P5, and P6 (continued)

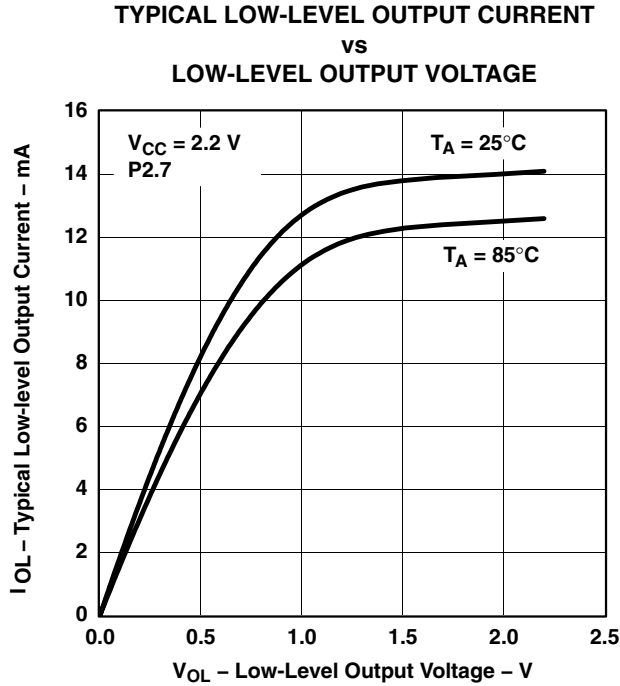

Figure 2

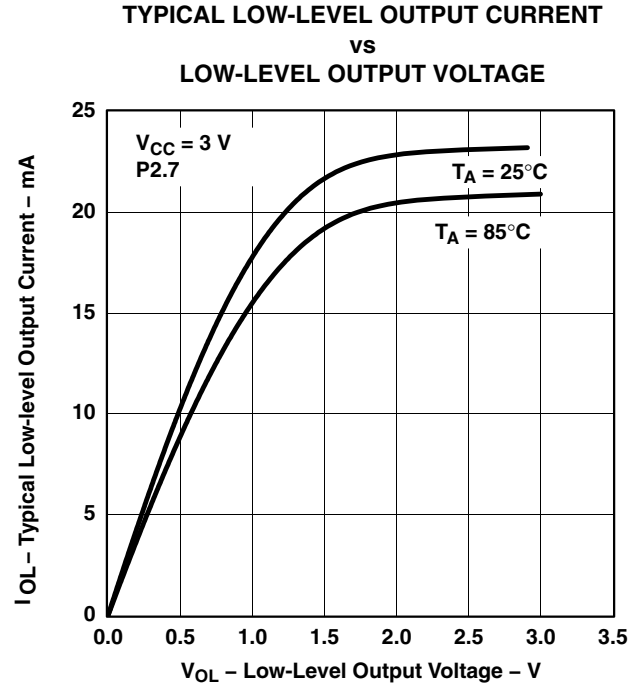

Figure 3

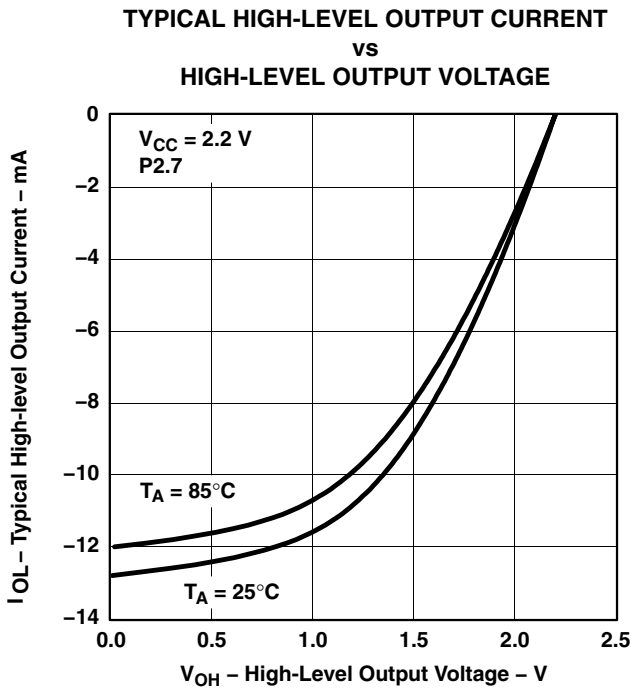

Figure 4

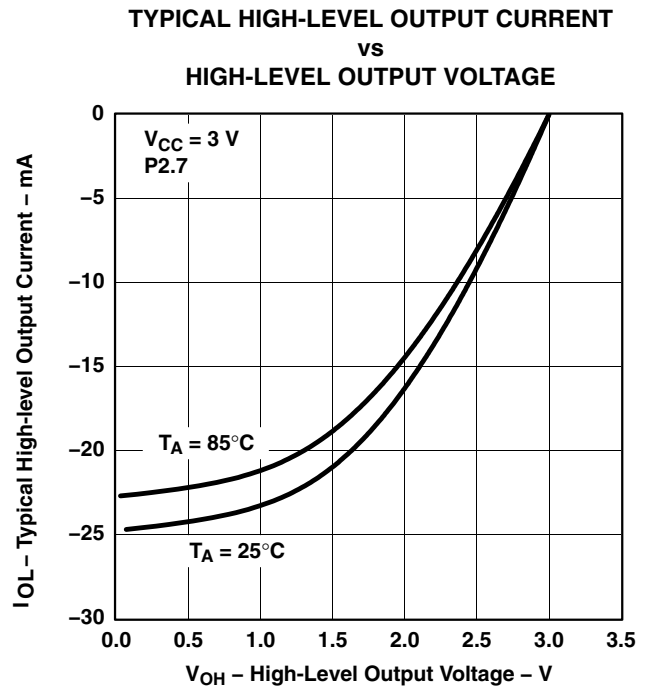

Figure 5

# MSP430x43x1, MSP430x43x, MSP430x44x1, MSP430x44x MIXED SIGNAL MICROCONTROLLER

SLAS344G – JANUARY 2002 – REVISED OCTOBER 2009

## electrical characteristics over recommended operating free-air temperature (unless otherwise noted) (continued)

### wake-up LPM3

PARAMETER		TEST CONDITIONS	V <sub>CC</sub>	MIN	TYP	MAX	UNIT
t <sub>d(LPM3)</sub>	Delay time	f = 1 MHz	2.2 V/3 V			6	μs
		f = 2 MHz				6	
		f = 3 MHz				6	

### RAM

PARAMETER	TEST CONDITIONS	MIN	TYP	MAX	UNIT
VRAMh	CPU halted (see Note 1)	1.6			V

NOTE 1: This parameter defines the minimum supply voltage when the data in program memory RAM remain unchanged. No program execution should take place during this supply voltage condition.

### LCD

PARAMETER		TEST CONDITIONS		MIN	TYP	MAX	UNIT
V <sub>(33)</sub>	Analog voltage	Voltage at P5.7/R33	V <sub>CC</sub> = 3 V	2.5		V <sub>CC</sub> + 0.2	V
V <sub>(23)</sub>		Voltage at P5.6/R23				$[V_{(33)} - V_{(03)}] \times 2/3 + V_{(03)}$	
V <sub>(13)</sub>		Voltage at P5.5/R13				$[V_{(33)} - V_{(03)}] \times 1/3 + V_{(03)}$	
V <sub>(33)</sub> - V <sub>(03)</sub>		Voltage at R33 to R03		2.5		V <sub>CC</sub> + 0.2	
I <sub>(R03)</sub>	Input leakage	R03 = V <sub>SS</sub>	No load at all segment and common lines, V <sub>CC</sub> = 3 V			±20	nA
I <sub>(R13)</sub>		P5.5/R13 = V <sub>CC</sub> /3				±20	
I <sub>(R23)</sub>		P5.6/R23 = 2 × V <sub>CC</sub> /3				±20	
V <sub>(Sxx0)</sub>	Segment line voltage	I <sub>(Sxx)</sub> = -3 μA, V <sub>CC</sub> = 3 V		V <sub>(03)</sub>		V <sub>(03)</sub> - 0.1	V
V <sub>(Sxx1)</sub>				V <sub>(13)</sub>		V <sub>(13)</sub> - 0.1	
V <sub>(Sxx2)</sub>				V <sub>(23)</sub>		V <sub>(23)</sub> - 0.1	
V <sub>(Sxx3)</sub>				V <sub>(33)</sub>		V <sub>(33)</sub> + 0.1	



# MSP430x43x1, MSP430x43x, MSP430x44x1, MSP430x44x MIXED SIGNAL MICROCONTROLLER

SLAS344G – JANUARY 2002 – REVISED OCTOBER 2009

**electrical characteristics over recommended operating free-air temperature (unless otherwise noted) (continued)**

## Comparator\_A (see Note 1)

PARAMETER	TEST CONDITIONS	V <sub>CC</sub>	MIN	TYP	MAX	UNIT
I <sub>(CC)</sub>	CAON=1, CARSEL=0, CAREF=0	2.2 V		25	40	μA
		3 V		45	60	
I <sub>(Refladder/RefDiode)</sub>	CAON=1, CARSEL=0, CAREF=1/2/3, No load at P1.6/CA0 and P1.7/CA1	2.2 V		30	50	μA
		3 V		45	71	
V <sub>(Ref025)</sub>	$\frac{\text{Voltage @ } 0.25 V_{CC} \text{ node}}{V_{CC}}$ PCA0=1, CARSEL=1, CAREF=1, No load at P1.6/CA0 and P1.7/CA1	2.2 V / 3 V	0.23	0.24	0.25	
V <sub>(Ref050)</sub>	$\frac{\text{Voltage @ } 0.5 V_{CC} \text{ node}}{V_{CC}}$ PCA0=1, CARSEL=1, CAREF=2, No load at P1.6/CA0 and P1.7/CA1	2.2V / 3 V	0.47	0.48	0.5	
V <sub>(RefVT)</sub>	See Figure 6 and Figure 7 PCA0=1, CARSEL=1, CAREF=3, No load at P1.6/CA0 and P1.7/CA1; T <sub>A</sub> = 85°C	2.2 V	390	480	540	mV
		3 V	400	490	550	
V <sub>IC</sub>	Common-mode input voltage range CAON=1	2.2 V / 3 V	0		V <sub>CC</sub> -1	V
V <sub>p</sub> -V <sub>s</sub>	Offset voltage See Note 2	2.2 V / 3 V	-30		30	mV
V <sub>hys</sub>	Input hysteresis CAON = 1	2.2 V / 3 V	0	0.7	1.4	mV
t <sub>(response LH)</sub>	T <sub>A</sub> = 25°C, Overdrive 10 mV, without filter: CAF = 0	2.2 V	160	210	300	ns
		3 V	80	150	240	
	T <sub>A</sub> = 25°C Overdrive 10 mV, with filter: CAF = 1	2.2 V	1.4	1.9	3.4	μs
		3 V	0.9	1.5	2.6	
t <sub>(response HL)</sub>	T <sub>A</sub> = 25°C Overdrive 10 mV, without filter: CAF = 0	2.2 V	130	210	300	ns
		3 V	80	150	240	
	T <sub>A</sub> = 25°C, Overdrive 10 mV, with filter: CAF = 1	2.2 V	1.4	1.9	3.4	μs
		3 V	0.9	1.5	2.6	

- NOTES: 1. The leakage current for the Comparator\_A terminals is identical to I<sub>lkg(Px.x)</sub> specification.  
 2. The input offset voltage can be cancelled by using the CAEX bit to invert the Comparator\_A inputs on successive measurements. The two successive measurements are then summed together.



# MSP430x43x1, MSP430x43x, MSP430x44x1, MSP430x44x MIXED SIGNAL MICROCONTROLLER

SLAS344G – JANUARY 2002 – REVISED OCTOBER 2009

electrical characteristics over recommended operating free-air temperature (unless otherwise noted) (continued)

typical characteristics

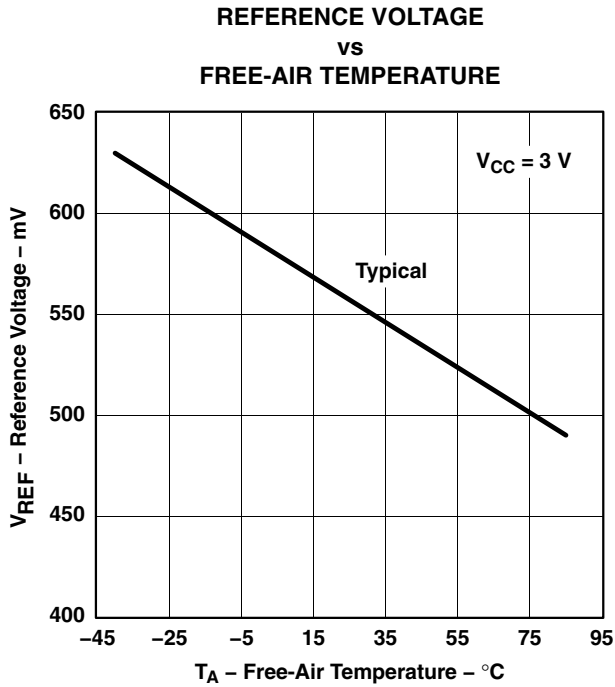

Figure 6. V<sub>(RefVT)</sub> vs Temperature

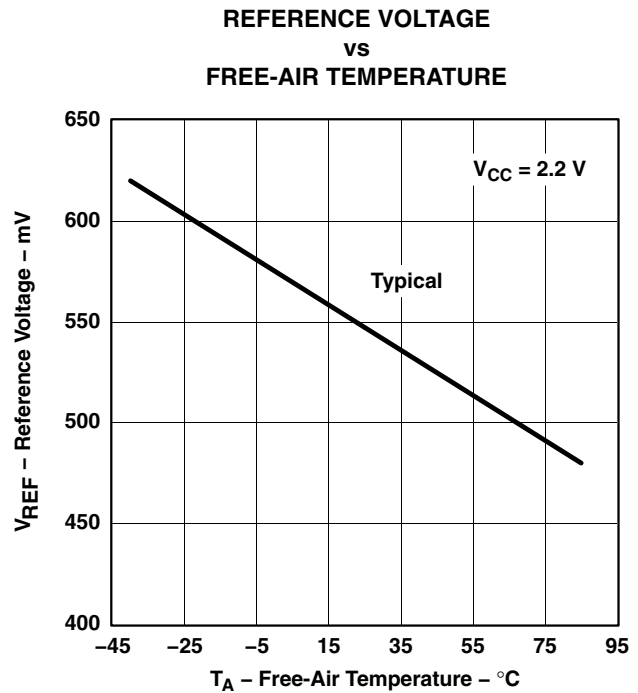

Figure 7. V<sub>(RefVT)</sub> vs Temperature

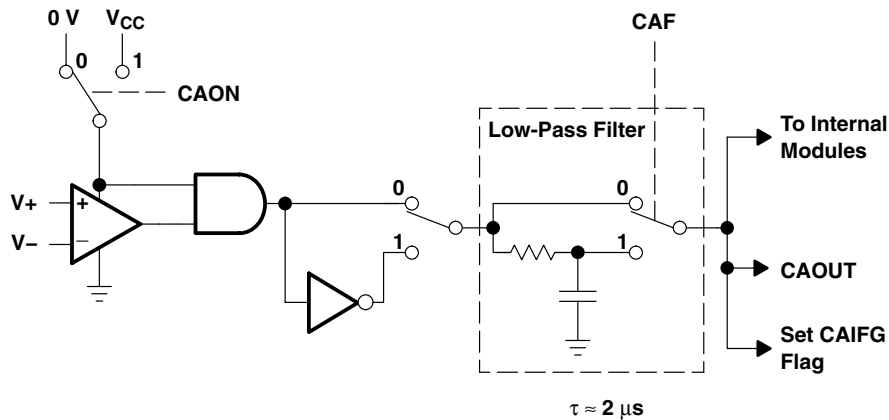

Figure 8. Block Diagram of Comparator\_A Module

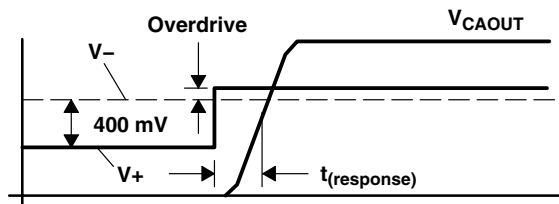

Figure 9. Overdrive Definition

electrical characteristics over recommended operating free-air temperature (unless otherwise noted) (continued)

POR/brownout reset (BOR) (see Note 1)

PARAMETER	TEST CONDITIONS	MIN	TYP	MAX	UNIT
$t_{d(BOR)}$				2000	$\mu\text{s}$
$V_{CC(start)}$	$dV_{CC}/dt \leq 3 \text{ V/s}$ (see Figure 10)		$0.7 \times V_{(B\_IT-)}$		V
$V_{(B\_IT-)}$	$dV_{CC}/dt \leq 3 \text{ V/s}$ (see Figure 10 through Figure 12)			1.71	V
$V_{hys(B\_IT-)}$	$dV_{CC}/dt \leq 3 \text{ V/s}$ (see Figure 10)	70	130	180	mV
$t_{(reset)}$	Pulse length needed at RST/NMI pin to accepted reset internally, $V_{CC} = 2.2 \text{ V}/3 \text{ V}$	2			$\mu\text{s}$

- NOTES: 1. The current consumption of the brownout module is already included in the  $I_{CC}$  current consumption data. The voltage level  $V_{(B\_IT-)} + V_{hys(B\_IT-)}$  is  $\leq 1.8\text{V}$ .
2. During power up, the CPU begins code execution following a period of  $t_{d(BOR)}$  after  $V_{CC} = V_{(B\_IT-)} + V_{hys(B\_IT-)}$ . The default FLL+ settings must not be changed until  $V_{CC} \geq V_{CC(min)}$ , where  $V_{CC(min)}$  is the minimum supply voltage for the desired operating frequency. See the *MSP430x4xx Family User's Guide (SLAU056)* for more information on the brownout/SVS circuit.

typical characteristics

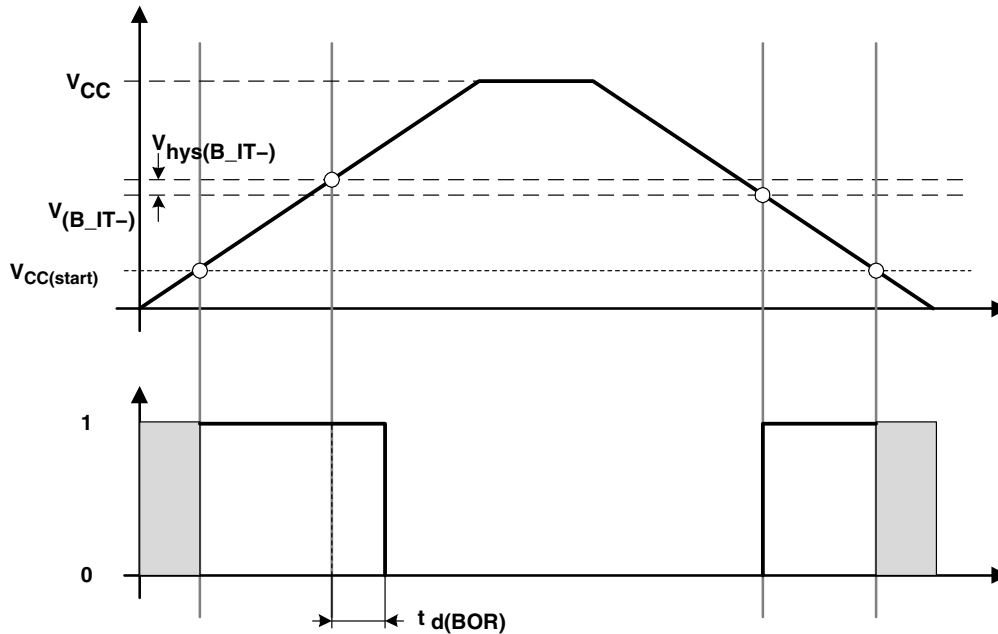

Figure 10. POR/Brownout Reset (BOR) vs Supply Voltage

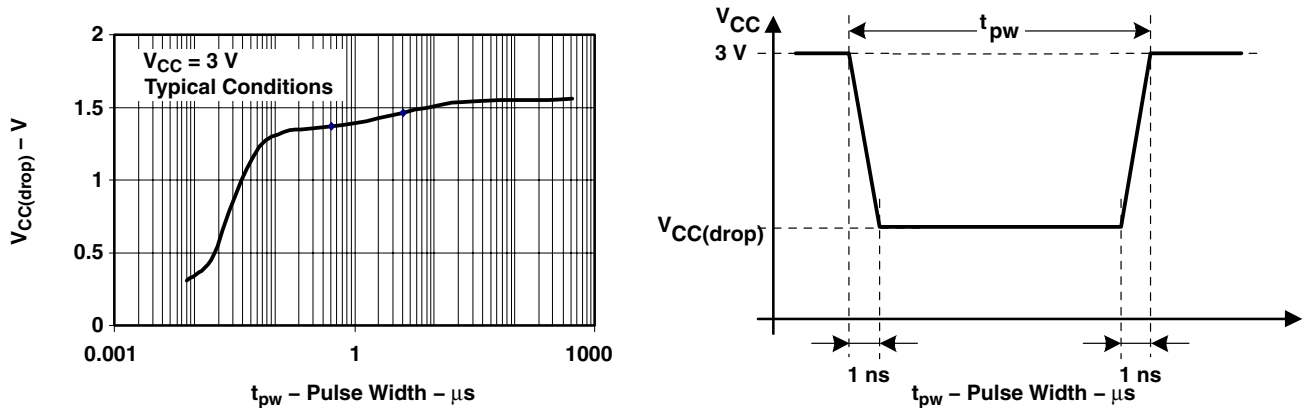

Figure 11.  $V_{CC(drop)}$  Level With a Square Voltage Drop to Generate a POR/Brownout Signal

# MSP430x43x1, MSP430x43x, MSP430x44x1, MSP430x44x MIXED SIGNAL MICROCONTROLLER

SLAS344G – JANUARY 2002 – REVISED OCTOBER 2009

## typical characteristics (Continued)

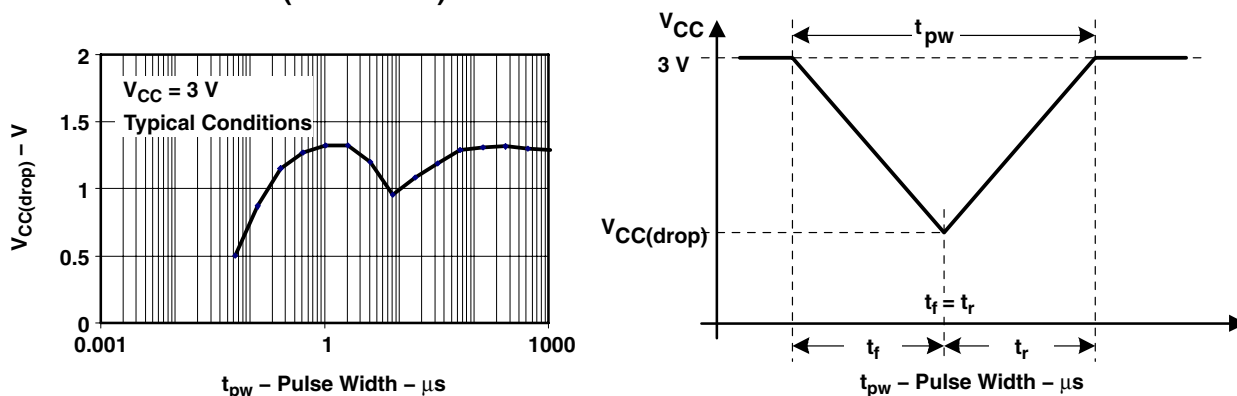

Figure 12.  $V_{CC(drop)}$  Level With a Triangle Voltage Drop to Generate a POR/Brownout Signal

## electrical characteristics over recommended operating free-air temperature (unless otherwise noted) (continued)

### supply voltage supervisor/monitor (SVS)

PARAMETER	TEST CONDITIONS	MIN	NOM	MAX	UNIT	
$t_{(SVSR)}$	$dV_{CC}/dt > 30 \text{ V/ms}$ (see Figure 13)	5		150	$\mu\text{s}$	
	$dV_{CC}/dt \leq 30 \text{ V/ms}$			2000	$\mu\text{s}$	
$t_{d(SVSON)}$	SVSON, switch from VLD=0 to VLD $\neq$ 0, $V_{CC} = 3 \text{ V}$	20		150	$\mu\text{s}$	
$t_{settle}$	VLD $\neq$ 0 <sup>†</sup>			12	$\mu\text{s}$	
$V_{(SVSstart)}$	VLD $\neq$ 0, $V_{CC}/dt \leq 3 \text{ V/s}$ (see Figure 13)		1.55	1.7	V	
$V_{hys(SVS\_IT-)}$	$V_{CC}/dt \leq 3 \text{ V/s}$ (see Figure 13)	VLD = 1	70	120	155	mV
		VLD = 2 to 14	$V_{(SVS\_IT-)} \times 0.004$		$V_{(SVS\_IT-)} \times 0.008$	
$V_{(SVS\_IT-)}$	$V_{CC}/dt \leq 3 \text{ V/s}$ (see Figure 13), external voltage applied on A7	VLD = 15	4.4		10.4	mV
		VLD = 1	1.8	1.9	2.05	V
		VLD = 2	1.94	2.1	2.25	
		VLD = 3	2.05	2.2	2.37	
		VLD = 4	2.14	2.3	2.48	
		VLD = 5	2.24	2.4	2.6	
		VLD = 6	2.33	2.5	2.71	
		VLD = 7	2.46	2.65	2.86	
		VLD = 8	2.58	2.8	3	
		VLD = 9	2.69	2.9	3.13	
		VLD = 10	2.83	3.05	3.29	
		VLD = 11	2.94	3.2	3.42	
		VLD = 12	3.11	3.35	3.61 <sup>†</sup>	
	VLD = 13	3.24	3.5	3.76 <sup>†</sup>		
VLD = 14	3.43	3.7 <sup>†</sup>	3.99 <sup>†</sup>			
$I_{CC(SVS)}$ (see Note 3)	VLD $\neq$ 0, $V_{CC} = 2.2 \text{ V}/3 \text{ V}$		10	15	$\mu\text{A}$	

<sup>†</sup> The recommended operating voltage range is limited to 3.6 V.

<sup>‡</sup>  $t_{settle}$  is the settling time that the comparator o/p needs to have a stable level after VLD is switched VLD  $\neq$  0 to a different VLD value somewhere between 2 and 15. The overdrive is assumed to be  $> 50 \text{ mV}$ .

NOTE 3: The current consumption of the SVS module is not included in the  $I_{CC}$  current consumption data.

typical characteristics

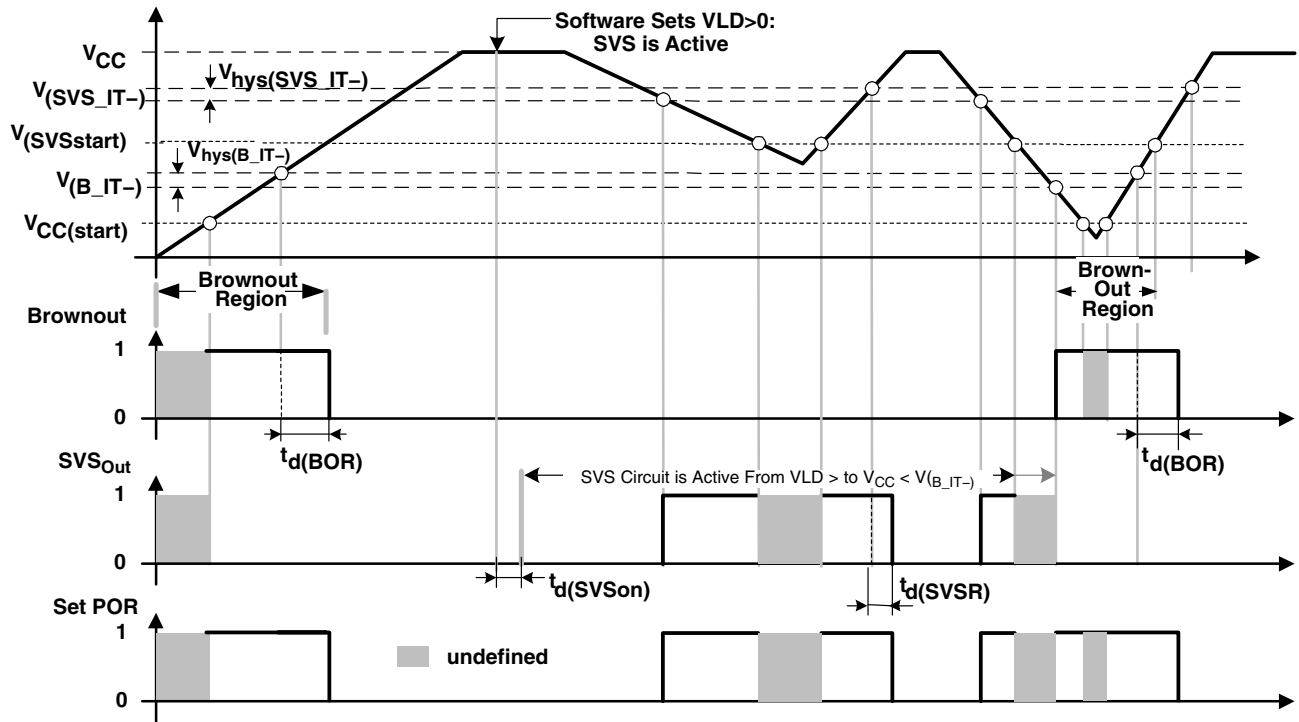

Figure 13. SVS Reset (SVSR) vs Supply Voltage

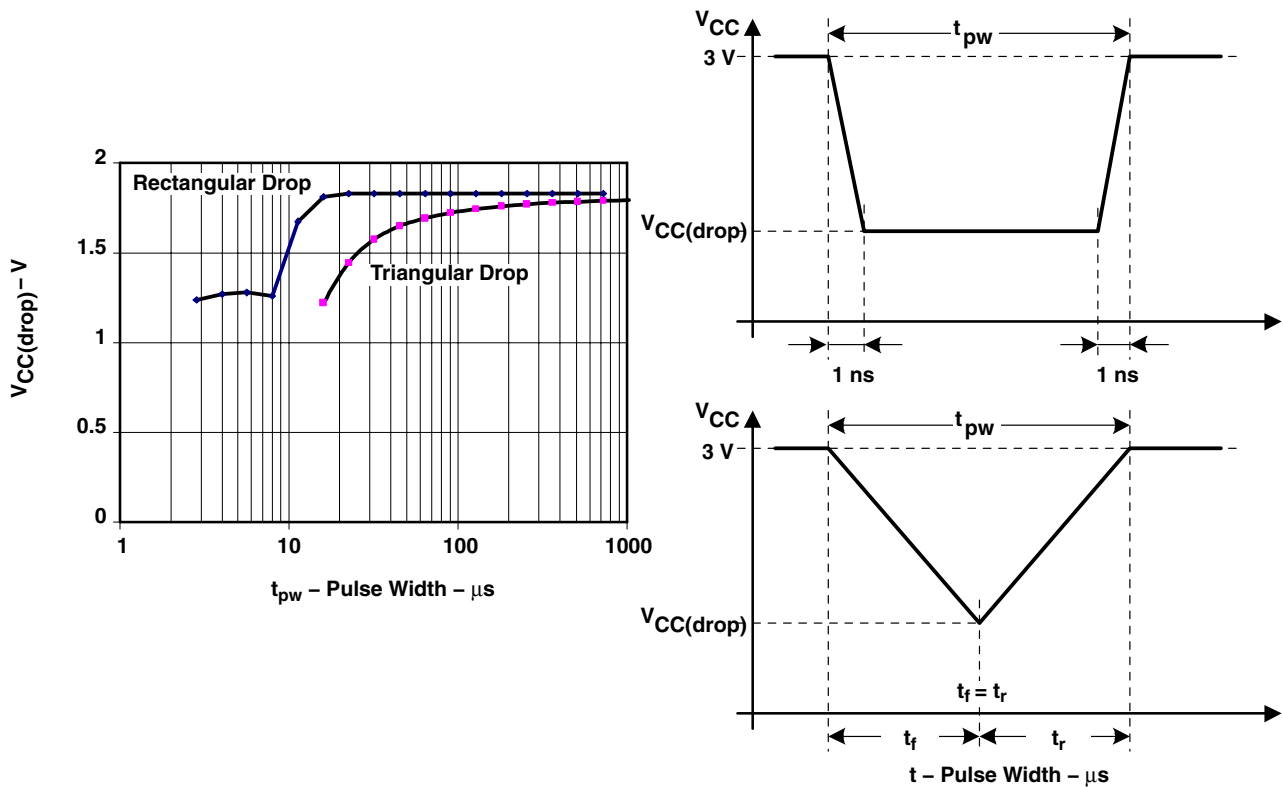

Figure 14.  $V_{CC(drop)}$  With a Square Voltage Drop and a Triangle Voltage Drop to Generate an SVS Signal

# MSP430x43x1, MSP430x43x, MSP430x44x1, MSP430x44x MIXED SIGNAL MICROCONTROLLER

SLAS344G – JANUARY 2002 – REVISED OCTOBER 2009

## electrical characteristics over recommended operating free-air temperature (unless otherwise noted) (continued)

### DCO

PARAMETER	TEST CONDITIONS	MIN	TYP	MAX	UNIT	
$f_{(DCOCLK)}$	$N_{(DCO)}=01Eh$ , $FN_8=FN_4=FN_3=FN_2=0$ , $D = 2$ ; $DCOPLUS= 0$ , $f_{Crystal} = 32.768$ kHz	$V_{CC} = 2.2$ V/3 V			1	MHz
$f_{(DCO=2)}$	$FN_8=FN_4=FN_3=FN_2=0$ ; $DCOPLUS = 1$	$V_{CC} = 2.2$ V			0.3 0.65 1.25	MHz
		$V_{CC} = 3$ V			0.3 0.7 1.3	
$f_{(DCO=27)}$	$FN_8=FN_4=FN_3=FN_2=0$ ; $DCOPLUS = 1$	$V_{CC} = 2.2$ V			2.5 5.6 10.5	MHz
		$V_{CC} = 3$ V			2.7 6.1 11.3	
$f_{(DCO=2)}$	$FN_8=FN_4=FN_3=0$ , $FN_2=1$ ; $DCOPLUS = 1$	$V_{CC} = 2.2$ V			0.7 1.3 2.3	MHz
		$V_{CC} = 3$ V			0.8 1.5 2.5	
$f_{(DCO=27)}$	$FN_8=FN_4=FN_3=0$ , $FN_2=1$ ; $DCOPLUS = 1$	$V_{CC} = 2.2$ V			5.7 10.8 18	MHz
		$V_{CC} = 3$ V			6.5 12.1 20	
$f_{(DCO=2)}$	$FN_8=FN_4=0$ , $FN_3= 1$ , $FN_2=x$ ; $DCOPLUS = 1$	$V_{CC} = 2.2$ V			1.2 2 3	MHz
		$V_{CC} = 3$ V			1.3 2.2 3.5	
$f_{(DCO=27)}$	$FN_8=FN_4=0$ , $FN_3= 1$ , $FN_2=x$ ; $DCOPLUS = 1$	$V_{CC} = 2.2$ V			9 15.5 25	MHz
		$V_{CC} = 3$ V			10.3 17.9 28.5	
$f_{(DCO=2)}$	$FN_8=0$ , $FN_4= 1$ , $FN_3= FN_2=x$ ; $DCOPLUS = 1$	$V_{CC} = 2.2$ V			1.8 2.8 4.2	MHz
		$V_{CC} = 3$ V			2.1 3.4 5.2	
$f_{(DCO=27)}$	$FN_8=0$ , $FN_4=1$ , $FN_3= FN_2=x$ ; $DCOPLUS = 1$	$V_{CC} = 2.2$ V			13.5 21.5 33	MHz
		$V_{CC} = 3$ V			16 26.6 41	
$f_{(DCO=2)}$	$FN_8=1$ , $FN_4=FN_3=FN_2=x$ ; $DCOPLUS = 1$	$V_{CC} = 2.2$ V			2.8 4.2 6.2	MHz
		$V_{CC} = 3$ V			4.2 6.3 9.2	
$f_{(DCO=27)}$	$FN_8=1$ , $FN_4=FN_3=FN_2=x$ ; $DCOPLUS = 1$	$V_{CC} = 2.2$ V			21 32 46	MHz
		$V_{CC} = 3$ V			30 46 70	
$S_n$	Step size between adjacent DCO taps: $S_n = f_{DCO(Tap\ n+1)} / f_{DCO(Tap\ n)}$ , (see Figure 16 for taps 21 to 27)	$1 < TAP \leq 20$			1.06 1.11	
		TAP = 27			1.07 1.17	
$D_t$	Temperature drift, $N_{(DCO)} = 01Eh$ , $FN_8=FN_4=FN_3=FN_2=0$ $D = 2$ ; $DCOPLUS = 0$	$V_{CC} = 2.2$ V			-0.2 -0.3 -0.4	%/°C
		$V_{CC} = 3$ V			-0.2 -0.3 -0.4	
$D_V$	Drift with $V_{CC}$ variation, $N_{(DCO)} = 01Eh$ , $FN_8=FN_4=FN_3=FN_2=0$ , $D = 2$ ; $DCOPLUS = 0$	$V_{CC} = 2.2$ V/3 V			0 5 15	%/V

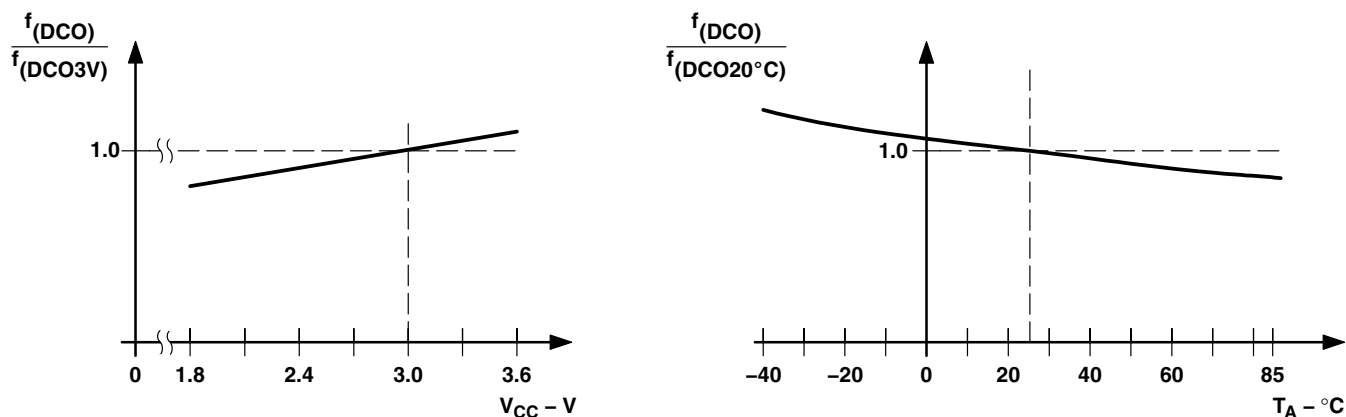

Figure 15. DCO Frequency vs Supply Voltage  $V_{CC}$  and vs Ambient Temperature



electrical characteristics over recommended operating free-air temperature (unless otherwise noted) (continued)

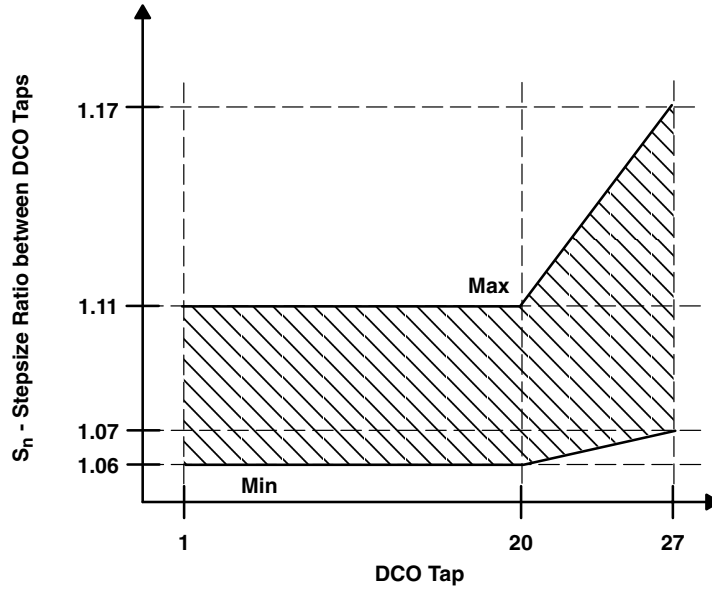

Figure 16. DCO Tap Step Size

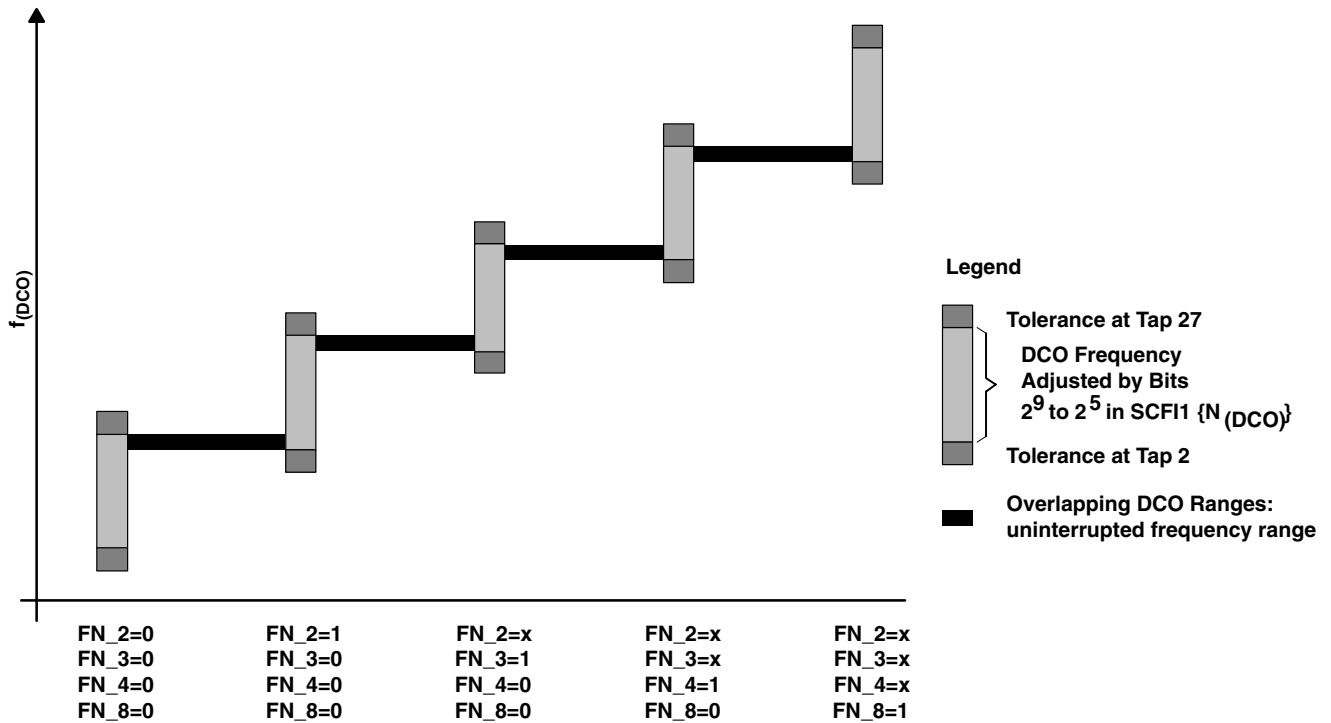

Figure 17. Five Overlapping DCO Ranges Controlled by FN\_x Bits

# MSP430x43x1, MSP430x43x, MSP430x44x1, MSP430x44x MIXED SIGNAL MICROCONTROLLER

SLAS344G – JANUARY 2002 – REVISED OCTOBER 2009

## electrical characteristics over recommended operating free-air temperature (unless otherwise noted) (continued)

### crystal oscillator, LFXT1 oscillator (see Notes 1 and 2)

PARAMETER		TEST CONDITIONS	V <sub>CC</sub>	MIN	TYP	MAX	UNIT
C <sub>XIN</sub>	Integrated input capacitance	OSCCAPx = 0h	2.2 V / 3 V		0		pF
		OSCCAPx = 1h	2.2 V/3 V		10		
		OSCCAPx = 2h	2.2 V/3 V		14		
		OSCCAPx = 3h	2.2 V/3 V		18		
C <sub>XOUT</sub>	Integrated output capacitance	OSCCAPx = 0h	2.2 V/3 V		0		pF
		OSCCAPx = 1h	2.2 V/3 V		10		
		OSCCAPx = 2h	2.2 V/3 V		14		
		OSCCAPx = 3h	2.2 V/3 V		18		
V <sub>IL</sub>	Input levels at XIN	See Note 3	2.2 V/3 V	V <sub>SS</sub>		0.2 × V <sub>CC</sub>	V
V <sub>IH</sub>				0.8 × V <sub>CC</sub>		V <sub>CC</sub>	V

- NOTES: 1. The parasitic capacitance from the package and board may be estimated to be 2 pF. The effective load capacitor for the crystal is  $(C_{XIN} \times C_{XOUT}) / (C_{XIN} + C_{XOUT})$ . This is independent of XTS\_FLL.
2. To improve EMI on the low-power LFXT1 oscillator, particularly in the LF mode (32 kHz), the following guidelines should be observed.
- Keep the trace between the 'F43x(1)/44x(1) and the crystal as short as possible.
  - Design a good ground plane around the oscillator pins.
  - Prevent crosstalk from other clock or data lines into oscillator pins XIN and XOUT.
  - Avoid running PCB traces underneath or adjacent to the XIN and XOUT pins.
  - Use assembly materials and praxis to avoid any parasitic load on the oscillator XIN and XOUT pins.
  - If conformal coating is used, ensure that it does not induce capacitive/resistive leakage between the oscillator pins.
  - Do not route the XOUT line to the JTAG header to support the serial programming adapter as shown in other documentation. This signal is no longer required for the serial programming adapter.
3. Applies only when using an external logic-level clock source. XTS\_FLL must be set. Not applicable when using a crystal or resonator.
4. External capacitance is recommended for precision real-time clock applications; OSCCAPx = 0h.

### crystal oscillator, XT2 oscillator (see Note 1)

PARAMETER		TEST CONDITIONS	MIN	NOM	MAX	UNIT
C <sub>XT2IN</sub>	Integrated input capacitance	V <sub>CC</sub> = 2.2 V/3 V		2		pF
C <sub>XT2OUT</sub>	Integrated output capacitance	V <sub>CC</sub> = 2.2 V/3 V		2		pF
V <sub>IL</sub>	Input levels at XT2IN	V <sub>CC</sub> = 2.2 V/3 V (see Note 2)	V <sub>SS</sub>		0.2 × V <sub>CC</sub>	V
V <sub>IH</sub>			0.8 × V <sub>CC</sub>		V <sub>CC</sub>	V

- NOTES: 1. The oscillator needs capacitors at both terminals, with values specified by the crystal manufacturer.
2. Applies only when using an external logic-level clock source. Not applicable when using a crystal or resonator.

### USART0, USART1 (see Note 1)

PARAMETER		TEST CONDITIONS	MIN	NOM	MAX	UNIT
t <sub>(r)</sub>	USART0/1: deglitch time	V <sub>CC</sub> = 2.2 V, SYNC = 0, UART mode	200	430	800	ns
		V <sub>CC</sub> = 3 V, SYNC = 0, UART mode	150	280	500	

- NOTE 1: The signal applied to the USART0/1 receive signal/terminal (URXD0/1) should meet the timing requirements of t<sub>(r)</sub> to ensure that the URXS flip-flop is set. The URXS flip-flop is set with negative pulses meeting the minimum-timing condition of t<sub>(r)</sub>. The operating conditions to set the flag must be met independently from this timing constraint. The deglitch circuitry is active only on negative transitions on the URXD0/1 line.



# MSP430x43x1, MSP430x43x, MSP430x44x1, MSP430x44x MIXED SIGNAL MICROCONTROLLER

SLAS344G – JANUARY 2002 – REVISED OCTOBER 2009

**electrical characteristics over recommended operating free-air temperature (unless otherwise noted) (continued)**

## 12-bit ADC, power supply and input range conditions (see Note 1)

PARAMETER		TEST CONDITIONS	V <sub>CC</sub>	MIN	NOM	MAX	UNIT
AV <sub>CC</sub>	Analog supply voltage	AV <sub>CC</sub> and DV <sub>CC</sub> are connected together, AV <sub>SS</sub> and DV <sub>SS</sub> are connected together, V <sub>(AVSS)</sub> = V <sub>(DVSS)</sub> = 0 V		2.2		3.6	V
V <sub>(P6.x/Ax)</sub>	Analog input voltage range (see Note 2)	All P6.0/A0 to P6.7/A7 terminals. Analog inputs selected in ADC12MCTLx register and P6Sel.x=1, 0 ≤ x ≤ 7; V <sub>(AVSS)</sub> ≤ V <sub>P6.x/Ax</sub> ≤ V <sub>(AVCC)</sub>		0		V <sub>AVCC</sub>	V
I <sub>ADC12</sub>	Operating supply current into AV <sub>CC</sub> terminal (see Note 3)	f <sub>ADC12CLK</sub> = 5.0 MHz ADC12ON = 1, REFON = 0 SHT0=0, SHT1=0, ADC12DIV=0	2.2 V		0.65	1.3	mA
			3 V		0.8	1.6	
I <sub>REF+</sub>	Operating supply current into AV <sub>CC</sub> terminal (see Note 4)	f <sub>ADC12CLK</sub> = 5.0 MHz ADC12ON = 0, REFON = 1, REF2_5V = 1	3 V		0.5	0.8	mA
			2.2 V		0.5	0.8	
		f <sub>ADC12CLK</sub> = 5.0 MHz ADC12ON = 0, REFON = 1, REF2_5V = 0	2.2 V		0.5	0.8	mA
			3 V		0.5	0.8	
C <sub>i</sub>	Input capacitance	Only one terminal can be selected at one time, P6.x/Ax	2.2 V			40	pF
R <sub>i</sub>	Input MUX ON resistance	0V ≤ V <sub>Ax</sub> ≤ V <sub>AVCC</sub>	3 V			2000	Ω

- NOTES: 1. The leakage current is defined in the leakage current table with P6.x/Ax parameter.  
 2. The analog input voltage range must be within the selected reference voltage range V<sub>R+</sub> to V<sub>R-</sub> for valid conversion results.  
 3. The internal reference supply current is not included in current consumption parameter I<sub>ADC12</sub>.  
 4. The internal reference current is supplied via terminal AV<sub>CC</sub>. Consumption is independent of the ADC12ON control bit, unless a conversion is active. The REFON bit enables to settle the built-in reference before starting an A/D conversion.

## 12-bit ADC, external reference (see Note 1)

PARAMETER		TEST CONDITIONS	V <sub>CC</sub>	MIN	NOM	MAX	UNIT
V <sub>eREF+</sub>	Positive external reference voltage input	V <sub>eREF+</sub> > V <sub>REF-</sub> /V <sub>eREF-</sub> (see Note 2)		1.4		V <sub>AVCC</sub>	V
V <sub>REF-</sub> /V <sub>eREF-</sub>	Negative external reference voltage input	V <sub>eREF+</sub> > V <sub>REF-</sub> /V <sub>eREF-</sub> (see Note 3)		0		1.2	V
(V <sub>eREF+</sub> – V <sub>REF-</sub> )/V <sub>eREF-</sub>	Differential external reference voltage input	V <sub>eREF+</sub> > V <sub>REF-</sub> /V <sub>eREF-</sub> (see Note 4)		1.4		V <sub>AVCC</sub>	V
I <sub>VeREF+</sub>	Static input current	0V ≤ V <sub>eREF+</sub> ≤ V <sub>AVCC</sub>	2.2 V/3 V			±1	μA
I <sub>VREF-/VeREF-</sub>	Static input current	0V ≤ V <sub>eREF-</sub> ≤ V <sub>AVCC</sub>	2.2 V/3 V			±1	μA

- NOTES: 1. The external reference is used during conversion to charge and discharge the capacitance array. The input capacitance, C<sub>i</sub>, is also the dynamic load for an external reference during conversion. The dynamic impedance of the reference supply should follow the recommendations on analog-source impedance to allow the charge to settle for 12-bit accuracy.  
 2. The accuracy limits the minimum positive external reference voltage. Lower reference voltage levels may be applied with reduced accuracy requirements.  
 3. The accuracy limits the maximum negative external reference voltage. Higher reference voltage levels may be applied with reduced accuracy requirements.  
 4. The accuracy limits minimum external differential reference voltage. Lower differential reference voltage levels may be applied with reduced accuracy requirements.

# MSP430x43x1, MSP430x43x, MSP430x44x1, MSP430x44x MIXED SIGNAL MICROCONTROLLER

SLAS344G – JANUARY 2002 – REVISED OCTOBER 2009

## electrical characteristics over recommended operating free-air temperature (unless otherwise noted) (continued)

### 12-bit ADC, built-in reference

PARAMETER	TEST CONDITIONS	V <sub>CC</sub>	MIN	TYP	MAX	UNIT
V <sub>REF+</sub> Positive built-in reference voltage output	REF2_5V = 1 for 2.5 V I <sub>VREF+</sub> ≤ I <sub>VREF+max</sub>	3 V	2.4	2.5	2.6	V
	REF2_5V = 0 for 1.5 V I <sub>VREF+</sub> ≤ I <sub>VREF+max</sub>	2.2 V/3 V	1.44	1.5	1.56	
AV <sub>CC(min)</sub> AV <sub>CC</sub> minimum voltage, Positive built-in reference active	REF2_5V = 0, I <sub>VREF+</sub> ≤ 1mA		2.2			V
	REF2_5V = 1, I <sub>VREF+</sub> ≤ 0.5mA		V <sub>REF+</sub> + 0.15			
	REF2_5V = 1, I <sub>VREF+</sub> ≤ 1mA		V <sub>REF+</sub> + 0.15			
I <sub>VREF+</sub> Load current out of V <sub>REF+</sub> terminal		2.2 V	0.01		-0.5	mA
		3 V			-1	
I <sub>L(VREF)+</sub> Load-current regulation V <sub>REF+</sub> terminal	I <sub>VREF+</sub> = 500 μA +/- 100 μA Analog input voltage ~0.75 V; REF2_5V = 0	2.2 V			±2	LSB
		3 V			±2	
	I <sub>VREF+</sub> = 500 μA ± 100 μA Analog input voltage ~1.25 V; REF2_5V = 1	3 V			±2	LSB
I <sub>DL(VREF)+</sub> Load current regulation V <sub>REF+</sub> terminal	I <sub>VREF+</sub> = 100 μA → 900 μA, C <sub>VREF+</sub> = 5 μF, A <sub>x</sub> ~0.5 x V <sub>REF+</sub> Error of conversion result ≤ 1 LSB	3 V			20	ns
C <sub>VREF+</sub> Capacitance at pin V <sub>REF+</sub> (see Note 1)	REFON = 1, 0 mA ≤ I <sub>VREF+</sub> ≤ I <sub>VREF+max</sub>	2.2 V/3 V	5	10		μF
T <sub>REF+</sub> Temperature coefficient of built-in reference	I <sub>VREF+</sub> is a constant in the range of 0 mA ≤ I <sub>VREF+</sub> ≤ 1 mA	2.2 V/3 V			±100	ppm/°C
t <sub>REFON</sub> Settle time of internal reference voltage (see Figure 18 and Note 2)	I <sub>VREF+</sub> = 0.5 mA, C <sub>VREF+</sub> = 10μF, V <sub>REF+</sub> = 1.5 V	2.2 V			17	ms

- NOTES: 1. The internal buffer operational amplifier and the accuracy specifications require an external capacitor. All INL and DNL tests uses two capacitors between pins V<sub>REF+</sub> and AV<sub>SS</sub> and V<sub>REF-</sub>/V<sub>eREF-</sub> and AV<sub>SS</sub>: 10 μF tantalum and 100 nF ceramic.  
2. The condition is that the error in a conversion started after t<sub>REFON</sub> is less than ±0.5 LSB. The settling time depends on the external capacitive load.

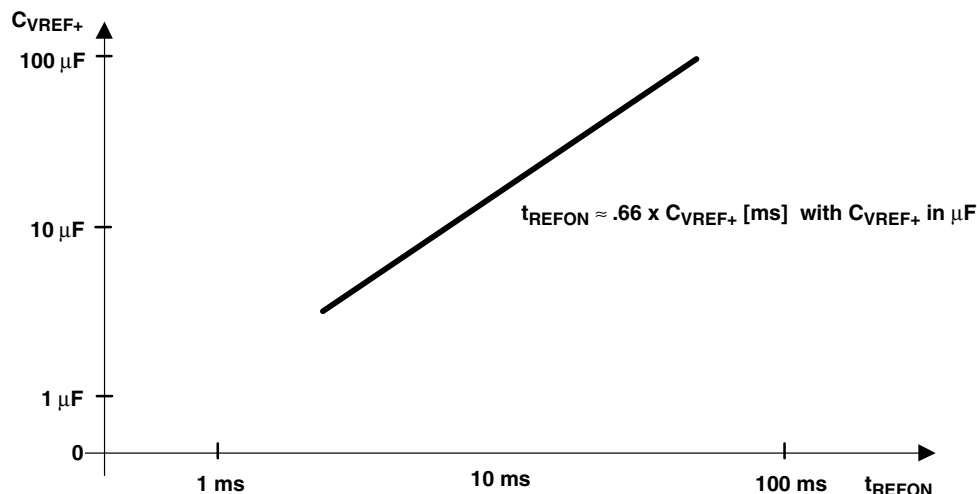

Figure 18. Typical Settling Time of Internal Reference t<sub>REFON</sub> vs External Capacitor on V<sub>REF+</sub>

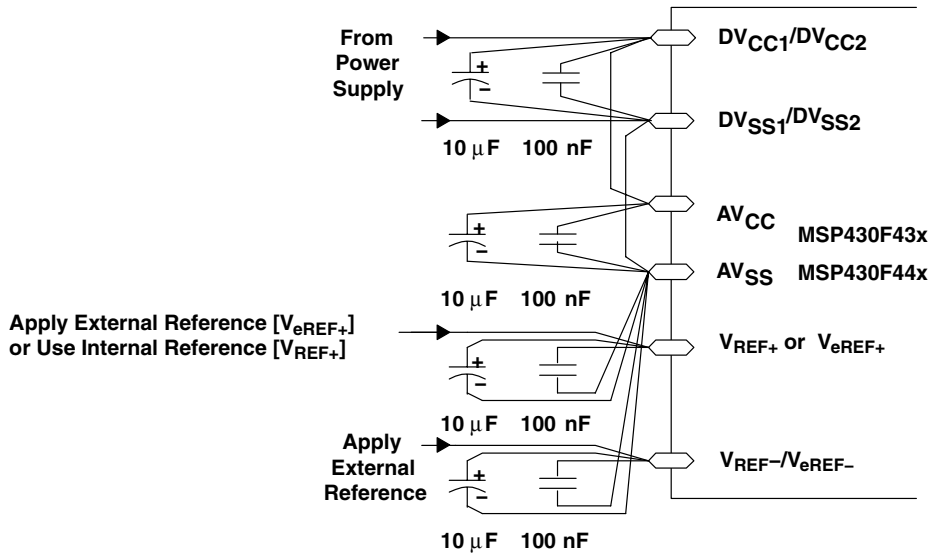

Figure 19. Supply Voltage and Reference Voltage Design  $V_{REF-}/V_{eREF-}$  External Supply

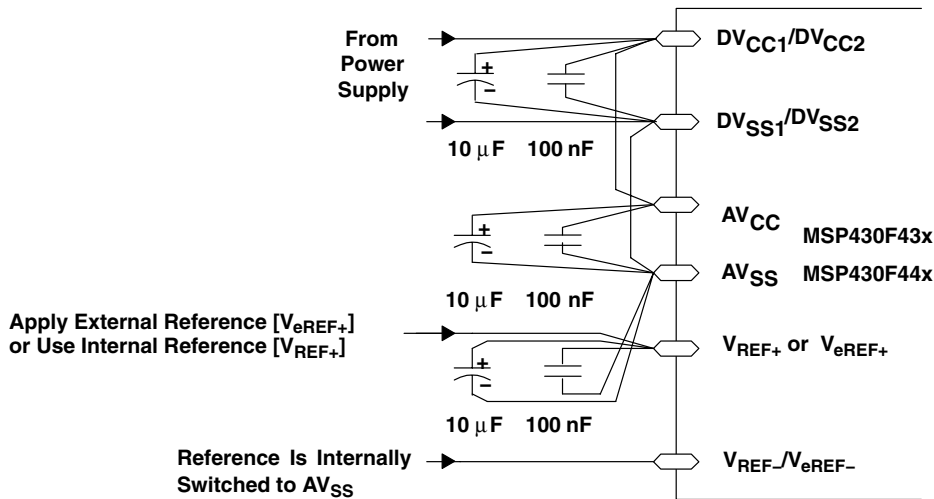

Figure 20. Supply Voltage and Reference Voltage Design  $V_{REF-}/V_{eREF-} = AV_{SS}$ , Internally Connected

# MSP430x43x1, MSP430x43x, MSP430x44x1, MSP430x44x MIXED SIGNAL MICROCONTROLLER

SLAS344G – JANUARY 2002 – REVISED OCTOBER 2009

## electrical characteristics over recommended operating free-air temperature (unless otherwise noted) (continued)

### 12-bit ADC, timing parameters

PARAMETER	TEST CONDITIONS	V <sub>CC</sub>	MIN	TYP	MAX	UNIT
f <sub>ADC12CLK</sub>	For specified performance of ADC12 linearity parameters	2.2V/3 V	0.45	5	6.3	MHz
f <sub>ADC12OSC</sub>	Internal ADC12 oscillator ADC12DIV=0, f <sub>ADC12CLK</sub> =f <sub>ADC12OSC</sub>	2.2 V/ 3 V	3.7		6.3	MHz
t <sub>CONVERT</sub>	Conversion time C <sub>VREF+</sub> ≥ 5 μF, Internal oscillator, f <sub>ADC12OSC</sub> = 3.7 MHz to 6.3 MHz	2.2 V/ 3 V	2.06		3.51	μs
	External f <sub>ADC12CLK</sub> from ACLK, MCLK or SMCLK: ADC12SSEL ≠ 0			13×ADC12DIV× 1/f <sub>ADC12CLK</sub>		μs
t <sub>ADC12ON</sub>	Turn on settling time of the ADC See Note 1				100	ns
t <sub>Sample</sub>	Sampling time R <sub>S</sub> = 400 Ω, R <sub>I</sub> = 1000 Ω, C <sub>I</sub> = 30 pF τ = [R <sub>S</sub> + R <sub>I</sub> ] × C <sub>I</sub> (see Note 2)	3 V	1220			ns
		2.2 V	1400			

- NOTES: 1. The condition is that the error in a conversion started after t<sub>ADC12ON</sub> is less than ±0.5 LSB. The reference and input signal are already settled.  
2. Approximately ten Tau (τ) are needed to get an error of less than ±0.5 LSB:  
t<sub>sample</sub> = ln(2<sup>n+1</sup>) × (R<sub>S</sub> + R<sub>I</sub>) × C<sub>I</sub> + 800 ns where n = ADC resolution = 12, R<sub>S</sub> = external source resistance.

### 12-bit ADC, linearity parameters

PARAMETER	TEST CONDITIONS	V <sub>CC</sub>	MIN	TYP	MAX	UNIT
E <sub>I</sub>	Integral linearity error 1.4 V ≤ (V <sub>eREF+</sub> - V <sub>REF-/V<sub>eREF-</sub></sub> ) min ≤ 1.6 V	2.2 V/3 V			±2	LSB
	1.6 V < (V <sub>eREF+</sub> - V <sub>REF-/V<sub>eREF-</sub></sub> ) min ≤ [V <sub>(AVCC)</sub> ]				±1.7	
E <sub>D</sub>	Differential linearity error (V <sub>eREF+</sub> - V <sub>REF-/V<sub>eREF-</sub></sub> ) <sub>min</sub> ≤ (V <sub>eREF+</sub> - V <sub>REF-/V<sub>eREF-</sub></sub> ), C <sub>VREF+</sub> = 10 μF (tantalum) and 100 nF (ceramic)	2.2 V/3 V			±1	LSB
E <sub>O</sub>	Offset error (V <sub>eREF+</sub> - V <sub>REF-/V<sub>eREF-</sub></sub> ) <sub>min</sub> ≤ (V <sub>eREF+</sub> - V <sub>REF-/V<sub>eREF-</sub></sub> ), Internal impedance of source R <sub>S</sub> < 100 Ω, C <sub>VREF+</sub> = 10 μF (tantalum) and 100 nF (ceramic)	2.2 V/3 V		±2	±4	LSB
E <sub>G</sub>	Gain error (V <sub>eREF+</sub> - V <sub>REF-/V<sub>eREF-</sub></sub> ) <sub>min</sub> ≤ (V <sub>eREF+</sub> - V <sub>REF-/V<sub>eREF-</sub></sub> ), C <sub>VREF+</sub> = 10 μF (tantalum) and 100 nF (ceramic)	2.2 V/3 V		±1.1	±2	LSB
E <sub>T</sub>	Total unadjusted error (V <sub>eREF+</sub> - V <sub>REF-/V<sub>eREF-</sub></sub> ) <sub>min</sub> ≤ (V <sub>eREF+</sub> - V <sub>REF-/V<sub>eREF-</sub></sub> ), C <sub>VREF+</sub> = 10 μF (tantalum) and 100 nF (ceramic)	2.2 V/3 V		±2	±5	LSB

# MSP430x43x1, MSP430x43x, MSP430x44x1, MSP430x44x MIXED SIGNAL MICROCONTROLLER

SLAS344G – JANUARY 2002 – REVISED OCTOBER 2009

electrical characteristics over recommended operating free-air temperature (unless otherwise noted) (continued)

## 12-bit ADC, temperature sensor and built-in $V_{MID}$

PARAMETER		TEST CONDITIONS	$V_{CC}$	MIN	TYP	MAX	UNIT
$I_{SENSOR}$	Operating supply current into $AV_{CC}$ terminal (see Note 1)	REFON = 0, INCH = 0Ah, ADC12ON=NA, $T_A = 25^\circ\text{C}$	2.2 V		40	120	$\mu\text{A}$
			3 V		60	160	
$V_{SENSOR}$		ADC12ON = 1, INCH = 0Ah, $T_A = 0^\circ\text{C}$	2.2 V		986	986±5%	mV
			3 V		986	986±5%	
$TC_{SENSOR}$		ADC12ON = 1, INCH = 0Ah	2.2 V		3.55	3.55±3%	mV/°C
			3 V		3.55	3.55±3%	
$t_{SENSOR(sample)}$	Sample time required if channel 10 is selected (see Note 2)	ADC12ON = 1, INCH = 0Ah, Error of conversion result ≤ 1 LSB	2.2 V	30			$\mu\text{s}$
			3 V	30			
$I_{VMID}$	Current into divider at channel 11	ADC12ON = 1, INCH = 0Bh, (see Note 3)	2.2 V			NA	$\mu\text{A}$
			3 V			NA	
$V_{MID}$	$AV_{CC}$ divider at channel 11	ADC12ON = 1, INCH = 0Bh, $V_{MID}$ is ~0.5 × $V_{AVCC}$	2.2 V		1.1	1.1±0.04	V
			3 V		1.5	1.50±0.04	
$t_{VMID(sample)}$	Sample time required if channel 11 is selected (see Note 4)	ADC12ON = 1, INCH = 0Bh, Error of conversion result ≤ 1 LSB	2.2 V	1400			ns
			3 V	1220			

- NOTES:
1. The sensor current  $I_{SENSOR}$  is consumed if (ADC12ON = 1 and REFON=1), or (ADC12ON=1 AND INCH=0Ah and sample signal is high). Therefore it includes the constant current through the sensor and the reference.
  2. The typical equivalent impedance of the sensor is 51 k $\Omega$ . The sample time required includes the sensor-on time  $t_{SENSOR(on)}$ .
  3. No additional current is needed. The  $V_{MID}$  is used during sampling.
  4. The on-time  $t_{VMID(on)}$  is included in the sampling time  $t_{VMID(sample)}$ ; no additional on time is needed.

# MSP430x43x1, MSP430x43x, MSP430x44x1, MSP430x44x MIXED SIGNAL MICROCONTROLLER

SLAS344G – JANUARY 2002 – REVISED OCTOBER 2009

## electrical characteristics over recommended operating free-air temperature (unless otherwise noted) (continued)

### flash memory

PARAMETER		TEST CONDITIONS	V <sub>CC</sub>	MIN	TYP	MAX	UNIT
V <sub>CC(PGM/ERASE)</sub>	Program and Erase supply voltage			2.7		3.6	V
f <sub>FTG</sub>	Flash Timing Generator frequency			257		476	kHz
I <sub>PGM</sub>	Supply current from DV <sub>CC</sub> during program		2.7 V/ 3.6 V		3	5	mA
I <sub>ERASE</sub>	Supply current from DV <sub>CC</sub> during erase		2.7 V/ 3.6 V		3	7	mA
t <sub>CPT</sub>	Cumulative program time	See Note 1	2.7 V/ 3.6 V			10	ms
t <sub>CMErase</sub>	Cumulative mass erase time	See Note 2	2.7 V/ 3.6 V	200			ms
	Program/Erase endurance			10 <sup>4</sup>	10 <sup>5</sup>		cycles
t <sub>Retention</sub>	Data retention duration	T <sub>J</sub> = 25°C		100			years
t <sub>Word</sub>	Word or byte program time	see Note 3			35		t <sub>FTG</sub>
t <sub>Block, 0</sub>	Block program time for 1 <sup>st</sup> byte or word				30		
t <sub>Block, 1-63</sub>	Block program time for each additional byte or word				21		
t <sub>Block, End</sub>	Block program end-sequence wait time				6		
t <sub>Mass Erase</sub>	Mass erase time				5297		
t <sub>Seq Erase</sub>	Segment erase time				4819		

- NOTES: 1. The cumulative program time must not be exceeded when writing to a 64-byte flash block. This parameter applies to all programming methods: individual word/byte write and block write modes.
2. The mass erase duration generated by the flash timing generator is at least 11.1ms ( = 5297x1/f<sub>FTG,max</sub> = 5297x1/476kHz). To achieve the required cumulative mass erase time the Flash Controller's mass erase operation can be repeated until this time is met. (A worst case minimum of 19 cycles are required).
3. These values are hardwired into the Flash Controller's state machine (t<sub>FTG</sub> = 1/f<sub>FTG</sub>).

### JTAG interface

PARAMETER		TEST CONDITIONS	V <sub>CC</sub>	MIN	TYP	MAX	UNIT
f <sub>TCK</sub>	TCK input frequency	see Note 1	2.2 V	0		5	MHz
			3 V	0		10	MHz
R <sub>Internal</sub>	Internal pullup resistance on TMS, TCK, TDI/TCLK	see Note 2	2.2 V/ 3 V	25	60	90	kΩ

- NOTES: 1. f<sub>TCK</sub> may be restricted to meet the timing requirements of the module selected.
2. TMS, TDI/TCLK, and TCK pull-up resistors are implemented in all versions.

### JTAG fuse (see Note 1)

PARAMETER		TEST CONDITIONS	MIN	TYP	MAX	UNIT
V <sub>CC(FB)</sub>	Supply voltage during fuse-blow condition	T <sub>A</sub> = 25°C	2.5			V
V <sub>FB</sub>	Voltage level on TDI/TCLK for fuse-blow: F versions		6		7	V
I <sub>FB</sub>	Supply current into TDI/TCLK during fuse blow				100	mA
t <sub>FB</sub>	Time to blow fuse				1	ms

- NOTES: 1. Once the fuse is blown, no further access to the MSP430 JTAG/Test and emulation features is possible. The JTAG block is switched to bypass mode.



APPLICATION INFORMATION

input/output schematics

port P1, P1.0 to P1.5, input/output with Schmitt trigger

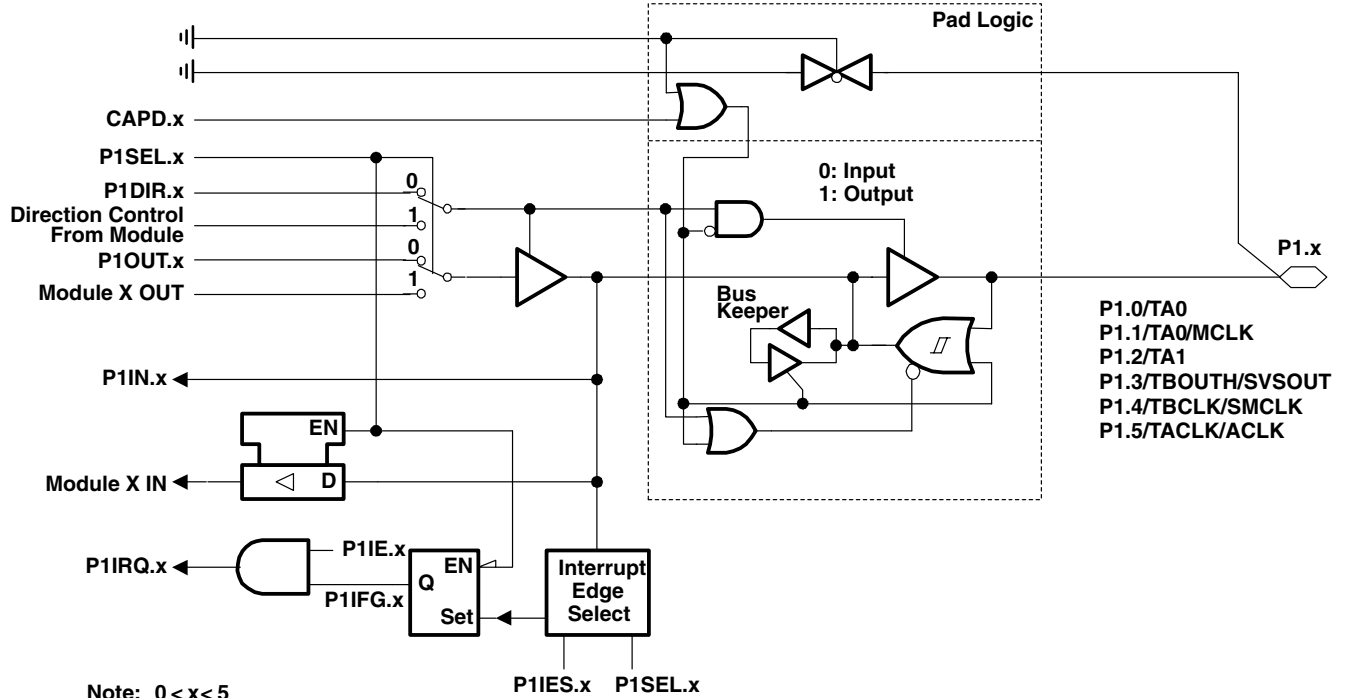

Note:  $0 \leq x \leq 5$

Note: Port function is active if CAPD.x = 0

PnSel.x	PnDIR.x	Direction Control From Module	PnOUT.x	Module X OUT	PnIN.x	Module X IN	PnIE.x	PnIFG.x	PnIES.x
P1Sel.0	P1DIR.0	P1DIR.0	P1OUT.0	Out0 sig. †	P1IN.0	CCI0A †	P1IE.0	P1IFG.0	P1IES.0
P1Sel.1	P1DIR.1	P1DIR.1	P1OUT.1	MCLK	P1IN.1	CCI0B †	P1IE.1	P1IFG.1	P1IES.1
P1Sel.2	P1DIR.2	P1DIR.2	P1OUT.2	Out1 sig. †	P1IN.2	CCI1A †	P1IE.2	P1IFG.2	P1IES.2
P1Sel.3	P1DIR.3	P1DIR.3	P1OUT.3	SVSOUT	P1IN.3	TBOUTH ‡	P1IE.3	P1IFG.3	P1IES.3
P1Sel.4	P1DIR.4	P1DIR.4	P1OUT.4	SMCLK	P1IN.4	TBCLK ‡	P1IE.4	P1IFG.4	P1IES.4
P1Sel.5	P1DIR.5	P1DIR.5	P1OUT.5	ACLK	P1IN.5	TACLK †	P1IE.5	P1IFG.5	P1IES.5

† Timer\_A

‡ Timer\_B

# MSP430x43x1, MSP430x43x, MSP430x44x1, MSP430x44x MIXED SIGNAL MICROCONTROLLER

SLAS344G – JANUARY 2002 – REVISED OCTOBER 2009

## APPLICATION INFORMATION

### port P1, P1.6, P1.7, input/output with Schmitt trigger

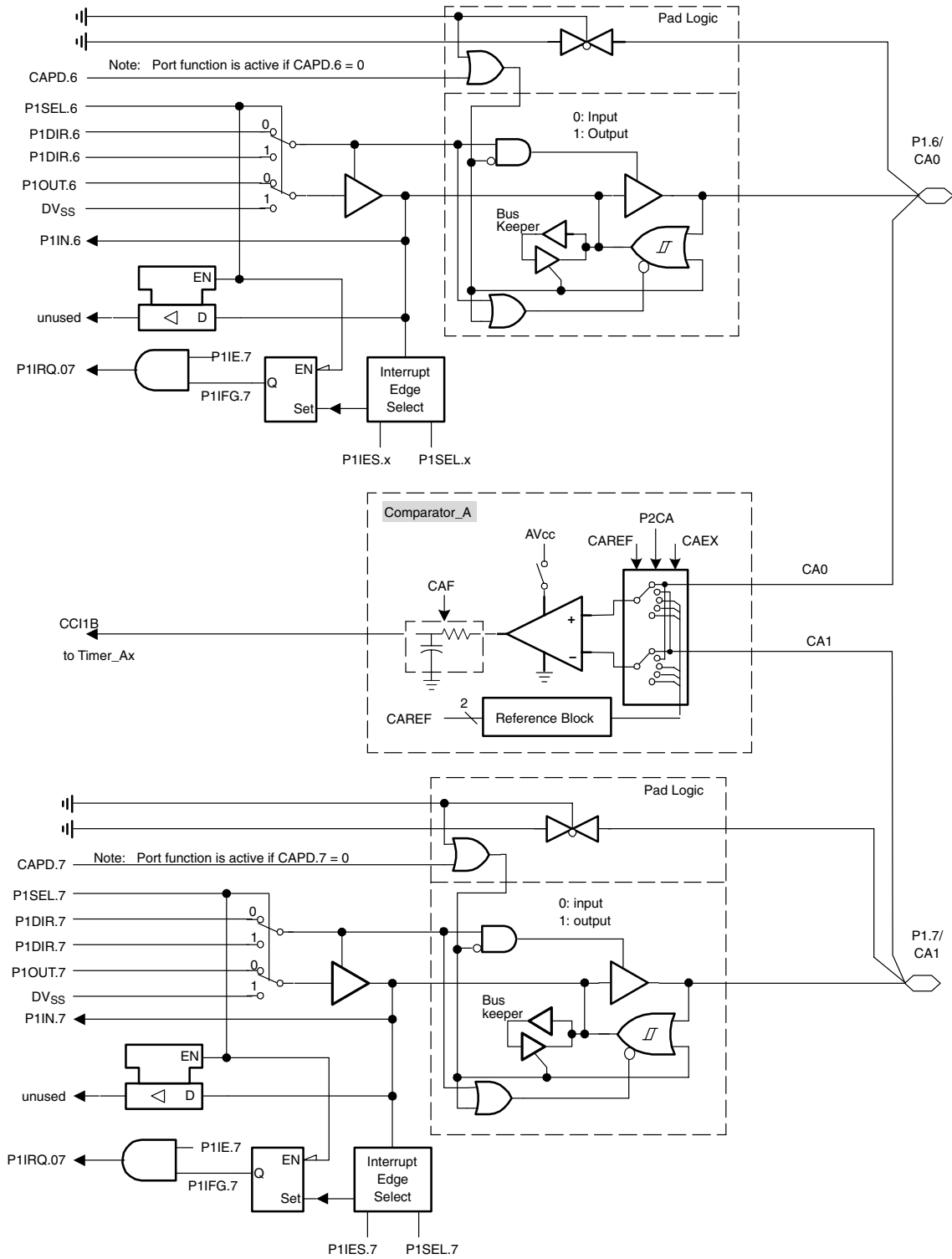



# MSP430x43x1, MSP430x43x, MSP430x44x1, MSP430x44x MIXED SIGNAL MICROCONTROLLER

SLAS344G – JANUARY 2002 – REVISED OCTOBER 2009

## APPLICATION INFORMATION

### port P2, P2.1 to P2.3, input/output with Schmitt trigger

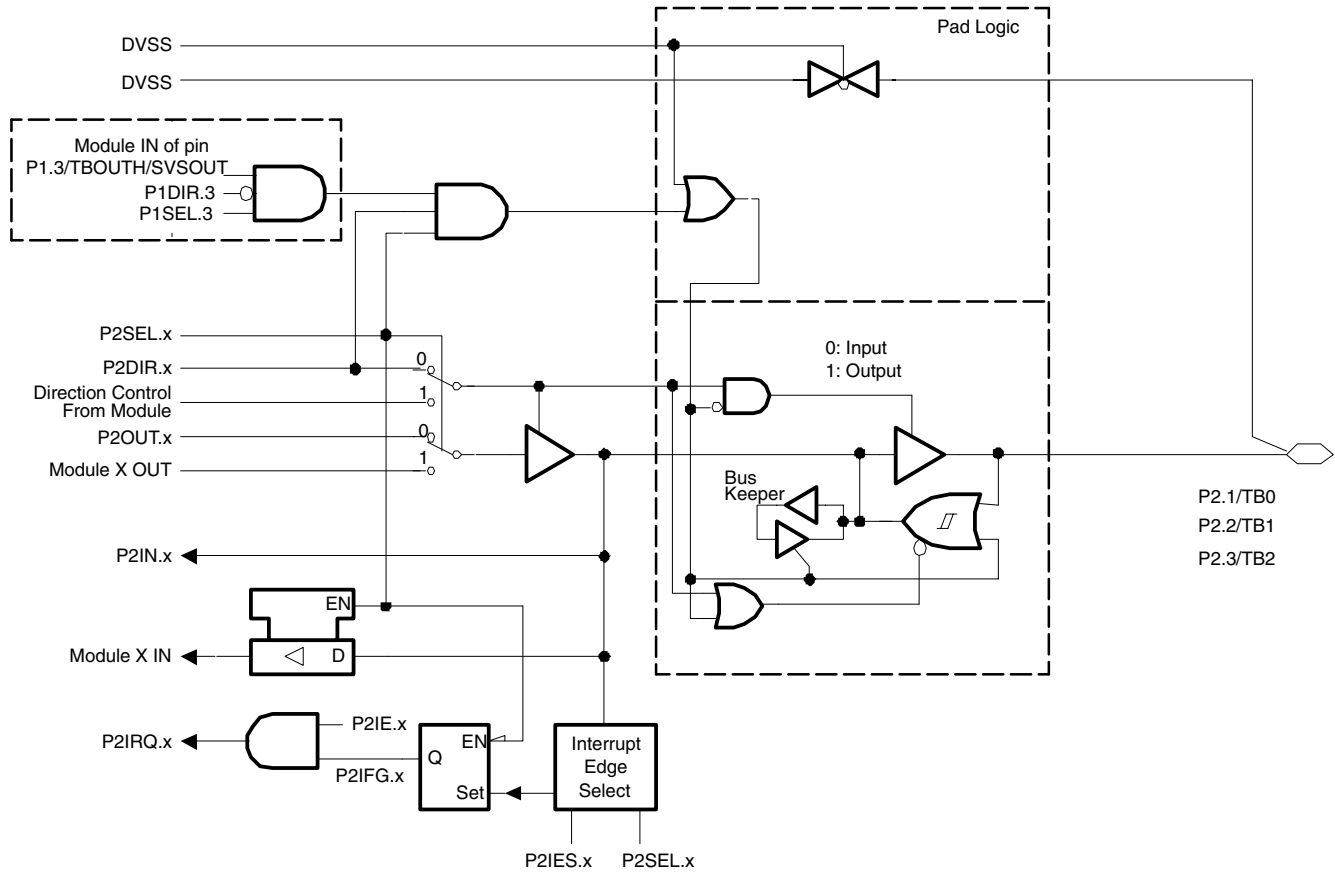

Note:  $1 \leq x \leq 3$

PnSel.x	PnDIR.x	Dir. Control from module	PnOUT.x	Module X OUT	PnIN.x	Module X IN	PnIE.x	PnIFG.x	PnIES.x
P2Sel.1	P2DIR.1	P2DIR.1	P2OUT.1	Out0 sig. †	P2IN.1	CC10A † CC10B	P2IE.1	P2IFG.1	P2IES.1
P2Sel.2	P2DIR.2	P2DIR.2	P2OUT.2	Out1 sig. †	P2IN.2	CC11A † CC11B	P2IE.2	P2IFG.2	P2IES.2
P2Sel.3	P2DIR.3	P2DIR.3	P2OUT.3	Out2 sig. †	P2IN.3	CC12A † CC12B	P2IE.3	P2IFG.3	P2IES.3

†Timer\_B

APPLICATION INFORMATION

port P2, P2.6 to P2.7, input/output with Schmitt trigger

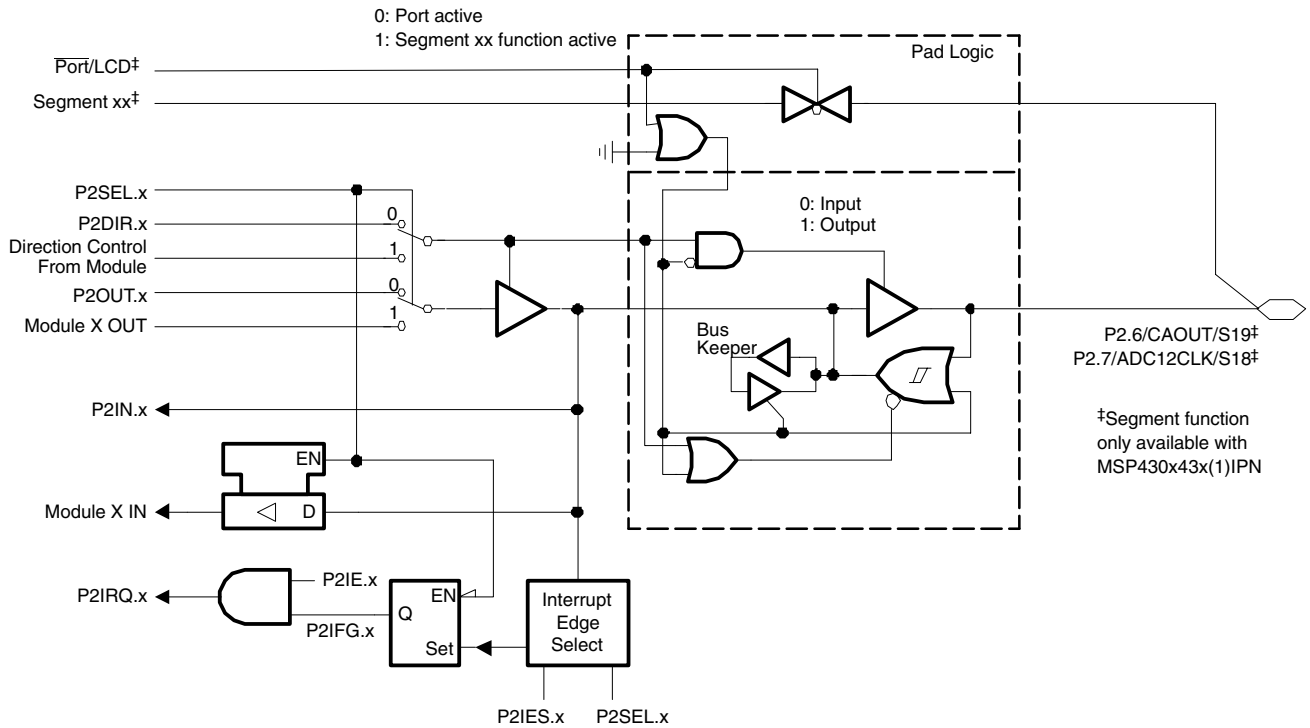

Note: 6 ≤ x ≤ 7

PnSel.x	PnDIR.x	Dir. Control from module	PnOUT.x	Module X OUT	PnIN.x	Module X IN	PnIE.x	PnIFG.x	PnIES.x	Port/LCD <sup>‡</sup>
P2Sel.6	P2DIR.6	P2DIR.6	P2OUT.6	CAOUT <sup>†</sup>	P2IN.6	unused	P2IE.6	P2IFG.6	P2IES.6	0: LCDM<40h <sup>‡</sup>
P2Sel.7	P2DIR.7	P2DIR.7	P2OUT.7	ADC12CLK <sup>§</sup>	P2IN.7	unused	P2IE.7	P2IFG.7	P2IES.7	0: LCDM<40h <sup>‡</sup>

<sup>†</sup> Comparator\_A

<sup>‡</sup>Port/LCD signal is 1 only with MSP430xIPN and LCDM ≥40h.

<sup>§</sup> ADC12

# MSP430x43x1, MSP430x43x, MSP430x44x1, MSP430x44x MIXED SIGNAL MICROCONTROLLER

SLAS344G – JANUARY 2002 – REVISED OCTOBER 2009

## APPLICATION INFORMATION

### port P3, P3.0 to P3.3, input/output with Schmitt trigger

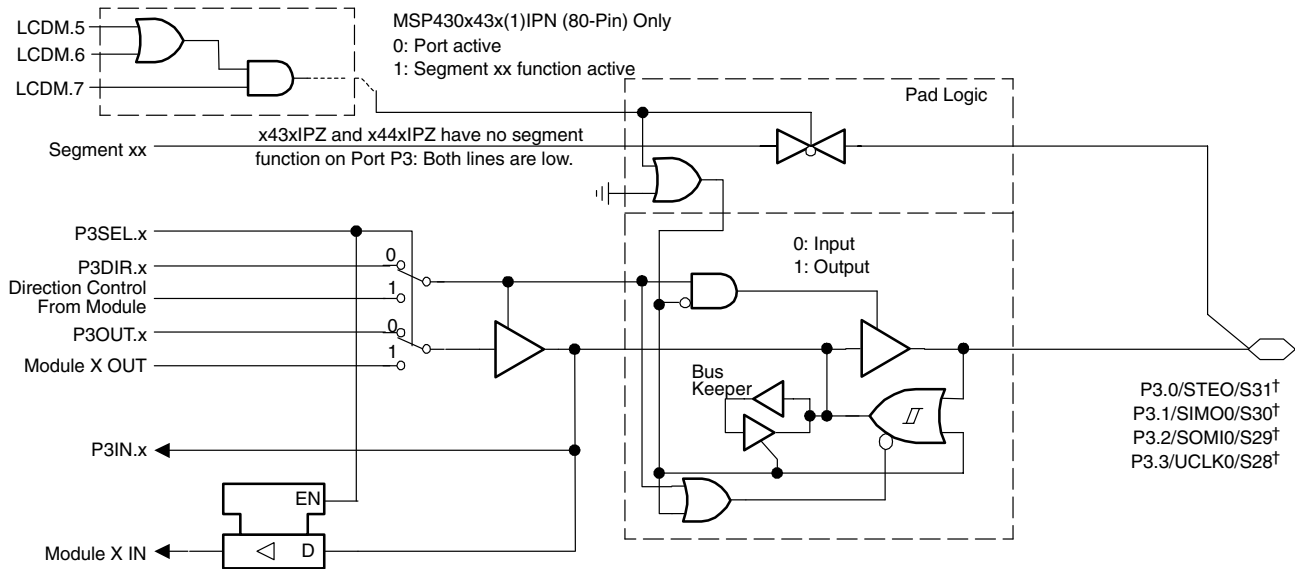

Note:  $0 \leq x \leq 3$

PnSel.x	PnDIR.x	Direction Control From Module	PnOUT.x	Module X OUT	PnIN.x	Module X IN
P3Sel.0	P3DIR.0	DV <sub>SS</sub>	P3OUT.0	DV <sub>SS</sub>	P3IN.0	STEO(in)
P3Sel.1	P3DIR.1	DCM_SIMO0	P3OUT.1	SIMO0(out)	P3IN.1	SIMO0(in)
P3Sel.2	P3DIR.2	DCM_SOMI0	P3OUT.2	SOMI0(out)	P3IN.2	SOMI0(in)
P3Sel.3	P3DIR.3	DCM_UCLK0	P3OUT.3	UCLK0(out)	P3IN.3	UCLK0(in)

† S24 to S31 shared with port function only at MSP430x43x(1)IPN (80-pin QFP)

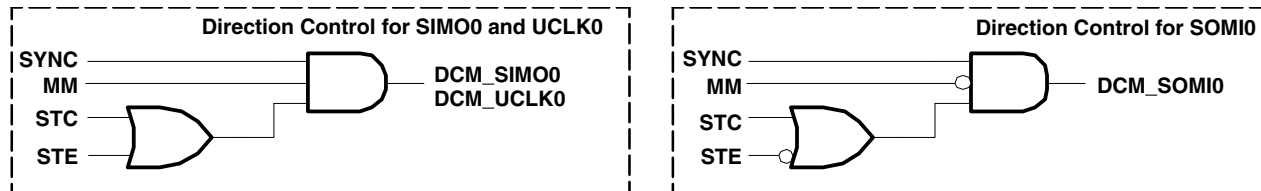

## APPLICATION INFORMATION

### port P3, P3.4 to P3.7, input/output with Schmitt trigger

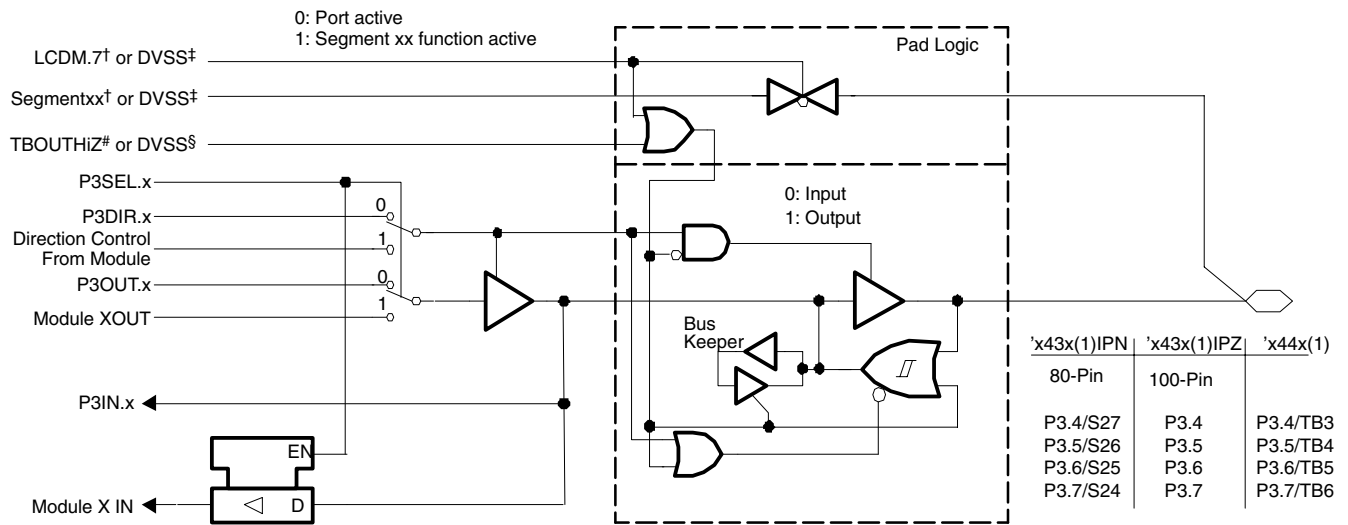

Note:  $4 \leq x \leq 7$

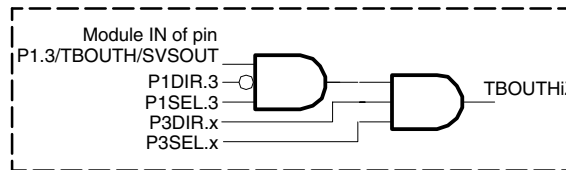

PnSel.x	PnDIR.x	Dir. Control from module	PnOUT.x	Module X OUT	PnIN.x	Module X IN
P3Sel.4	P3DIR.4	P3DIR.4	P3OUT.4	DVSS § OUT3 #	P3IN.4	unused § CCI3A/B#
P3Sel.5	P3DIR.5	P3DIR.5	P3OUT.5	DVSS § OUT4 #	P3IN.5	unused § CCI4A/B#
P3Sel.6	P3DIR.6	P3DIR.6	P3OUT.6	DVSS § OUT5 #	P3IN.6	unused § CCI5A/B#
P3Sel.7	P3DIR.7	P3DIR.7	P3OUT.7	DVSS § OUT6 #	P3IN.7	unused § CCI6A #

† MSP430x43x(1)IPN

‡ MSP430x43x(1)IPZ, MSP430x44x(1)IPZ

§ MSP430x43x(1)

# MSP430x44x(1)

# MSP430x43x1, MSP430x43x, MSP430x44x1, MSP430x44x MIXED SIGNAL MICROCONTROLLER

SLAS344G – JANUARY 2002 – REVISED OCTOBER 2009

## APPLICATION INFORMATION

### port P4, P4.0 to P4.7, input/output with Schmitt trigger

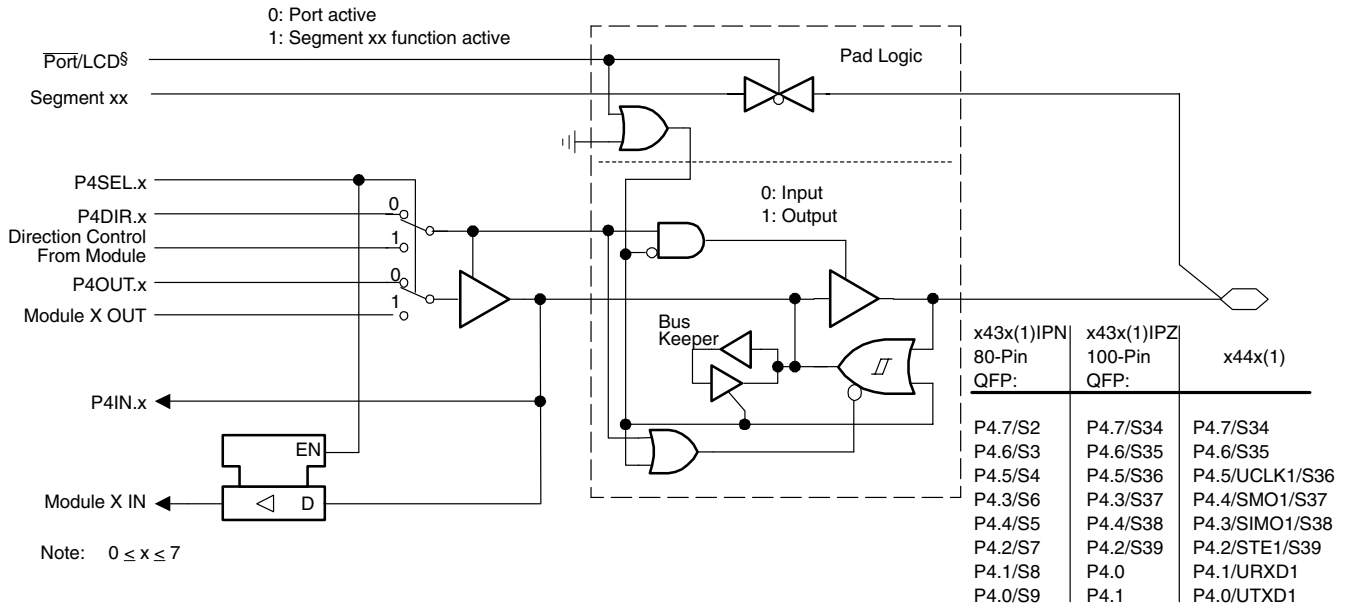

PnSel.x	PnDir.x	Direction Control From Module	PnOut.x	Module X OUT	PnIn.x	Module X IN
P4Sel.0	P4DIR.0	P4DIR.0 <sup>†</sup> DVCC <sub>‡</sub>	P4OUT.0	DVSS <sup>†</sup> UTXD1 <sup>‡</sup>	P4IN.0	unused
P4Sel.1	P4DIR.1	P4DIR.1 <sup>†</sup> DVSS <sub>‡</sub>	P4OUT.1	DVSS	P4IN.1	unused <sup>†</sup> URXD1 <sup>‡</sup>
P4Sel.2	P4DIR.2	P4DIR.2 <sup>†</sup> DVSS <sub>‡</sub>	P4OUT.2	DVSS	P4IN.2	unused <sup>†</sup> STE1(in) <sup>‡</sup>
P4Sel.3	P4DIR.3	P4DIR3. <sup>†</sup> DCM_SIMO1 <sub>‡</sub>	P4OUT.3	DVSS <sup>†</sup> SIMO1(out) <sup>‡</sup>	P4IN.3	unused <sup>†</sup> SIMO1(in) <sup>‡</sup>
P4Sel.4	P4DIR.4	P4DIR4. <sup>†</sup> DCM_SOMI1 <sub>‡</sub>	P4OUT.4	DVSS <sup>†</sup> SOMI1(out) <sup>‡</sup>	P4IN.4	unused <sup>†</sup> SOMI1(in) <sup>‡</sup>
P4Sel.5	P4DIR.5	P4DIR5. <sup>†</sup> DCM_UCLK1 <sub>‡</sub>	P4OUT.5	DVSS <sup>†</sup> UCLK1(out) <sup>‡</sup>	P4IN.5	unused <sup>†</sup> UCLK1(in) <sup>‡</sup>
P4Sel.6	P4DIR.6	P4DIR.6	P4OUT.6	DVSS	P4IN.6	unused
P4Sel.7	P4DIR.7	P4DIR.7	P4OUT.7	DVSS	P4IN.7	unused

<sup>†</sup> Signal at MSP430x43x(1)

<sup>‡</sup> Signal at MSP430x44x(1)

DEVICE	PORT BITS	PORT FUNCTION	LCD SEG. FUNCTION
x43x(1)IPN 80-pin QFP	P4.0 . . . P4.7	LCDM < 020h	LCDM ≥ 020h
x43x(1)IPZ 100-pin QFP	P4.2 . . . P4.5	LCDM < 0E0h	LCDM ≥ 0E0h
x44x(1)IPZ 100-pin QFP	P4.6 . . . P4.7	LCDM < 0C0h	LCDM ≥ 0C0h



APPLICATION INFORMATION

port P4, P4.0 to P4.7, input/output with Schmitt trigger (continued)

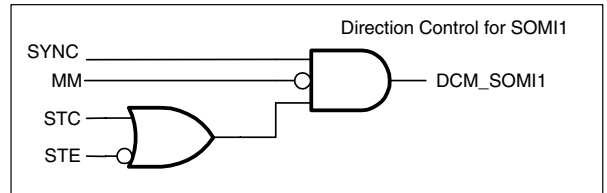
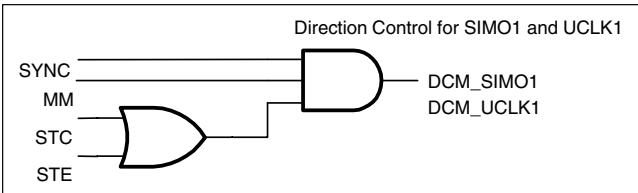

port P5, P5.0 to P5.1, input/output with Schmitt trigger

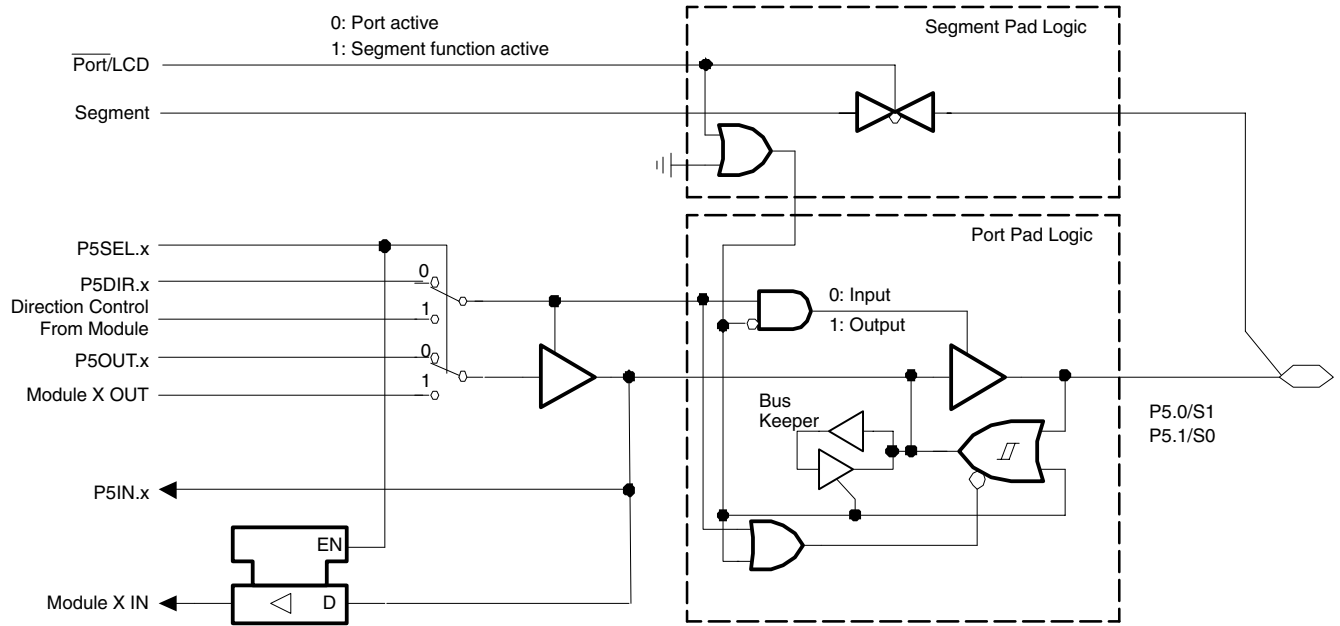

Note:  $0 \leq x \leq 1$

PnSel.x	PnDIR.x	Dir. Control from module	PnOUT.x	Module X OUT	PnIN.x	Module X IN	Segment	Port/LCD
P5Sel.0	P5DIR.0	P5DIR.0	P5OUT.0	DV <sub>SS</sub>	P5IN.0	unused	S1	0: LCDM<20h
P5Sel.1	P5DIR.1	P5DIR.1	P5OUT.1	DV <sub>SS</sub>	P5IN.1	unused	S0	0: LCDM<20h

# MSP430x43x1, MSP430x43x, MSP430x44x1, MSP430x44x MIXED SIGNAL MICROCONTROLLER

SLAS344G – JANUARY 2002 – REVISED OCTOBER 2009

## APPLICATION INFORMATION

### port P5, P5.2 to P5.4, input/output with Schmitt trigger

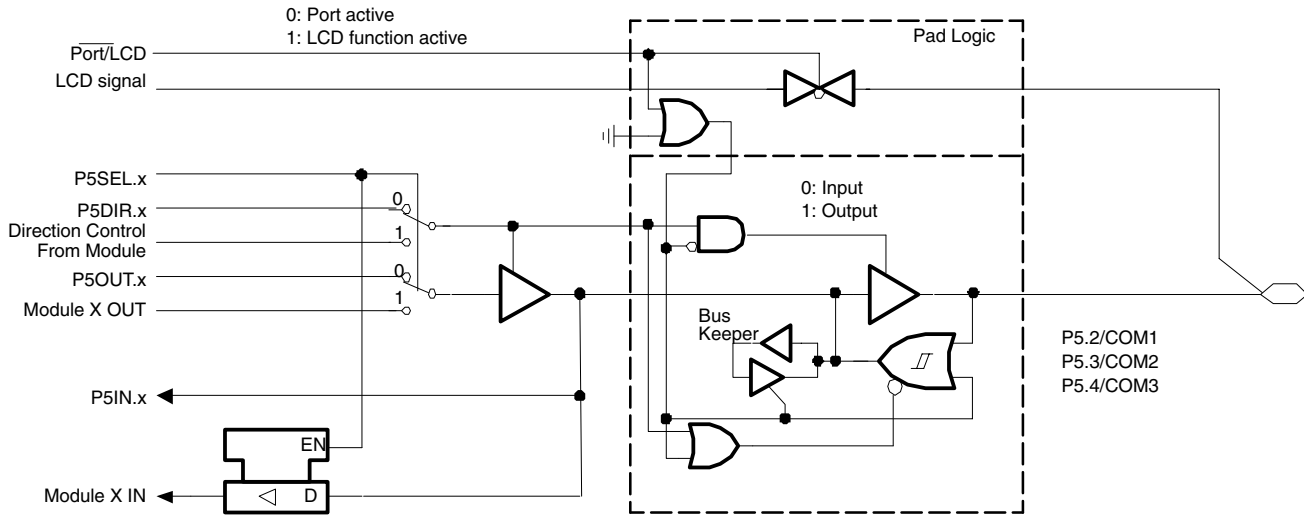

Note:  $2 \leq x \leq 4$

PnSel.x	PnDIR.x	Dir. Control from module	PnOUT.x	Module X OUT	PnIN.x	Module X IN	LCD signal	Port/LCD
P5Sel.2	P5DIR.2	P5DIR.2	P5OUT.2	DV <sub>SS</sub>	P5IN.2	unused	COM1	P5SEL.2
P5Sel.3	P5DIR.3	P5DIR.3	P5OUT.3	DV <sub>SS</sub>	P5IN.3	unused	COM2	P5SEL.3
P5Sel.4	P5DIR.4	P5DIR.4	P5OUT.4	DV <sub>SS</sub>	P5IN.4	unused	COM3	P5SEL.4

## APPLICATION INFORMATION

### port P5, P5.5 to P5.7, input/output with Schmitt trigger

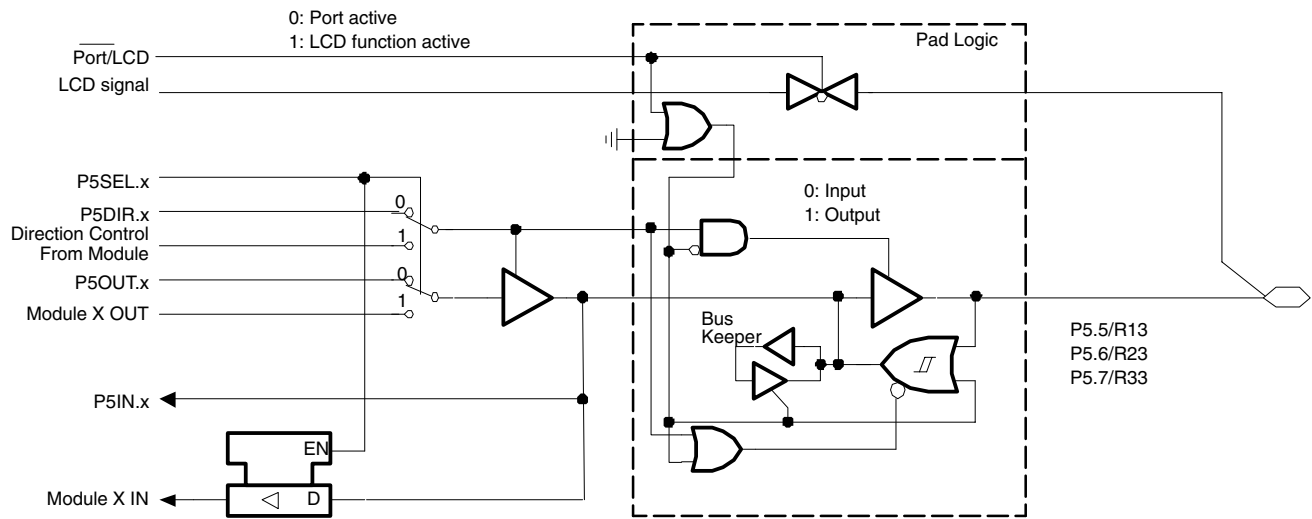

Note:  $5 \leq x \leq 7$

PnSel.x	PnDIR.x	Dir. Control from module	PnOUT.x	Module X OUT	PnIN.x	Module X IN	LCD signal	Port/LCD
P5Sel.5	P5DIR.5	P5DIR.5	P5OUT.5	DV <sub>SS</sub>	P5IN.5	unused	R13	P5SEL.5
P5Sel.6	P5DIR.6	P5DIR.6	P5OUT.6	DV <sub>SS</sub>	P5IN.6	unused	R23	P5SEL.6
P5Sel.7	P5DIR.7	P5DIR.7	P5OUT.7	DV <sub>SS</sub>	P5IN.7	unused	R33	P5SEL.7

# MSP430x43x1, MSP430x43x, MSP430x44x1, MSP430x44x MIXED SIGNAL MICROCONTROLLER

SLAS344G – JANUARY 2002 – REVISED OCTOBER 2009

## APPLICATION INFORMATION

### port P6, P6.0 to P6.6, input/output with Schmitt trigger

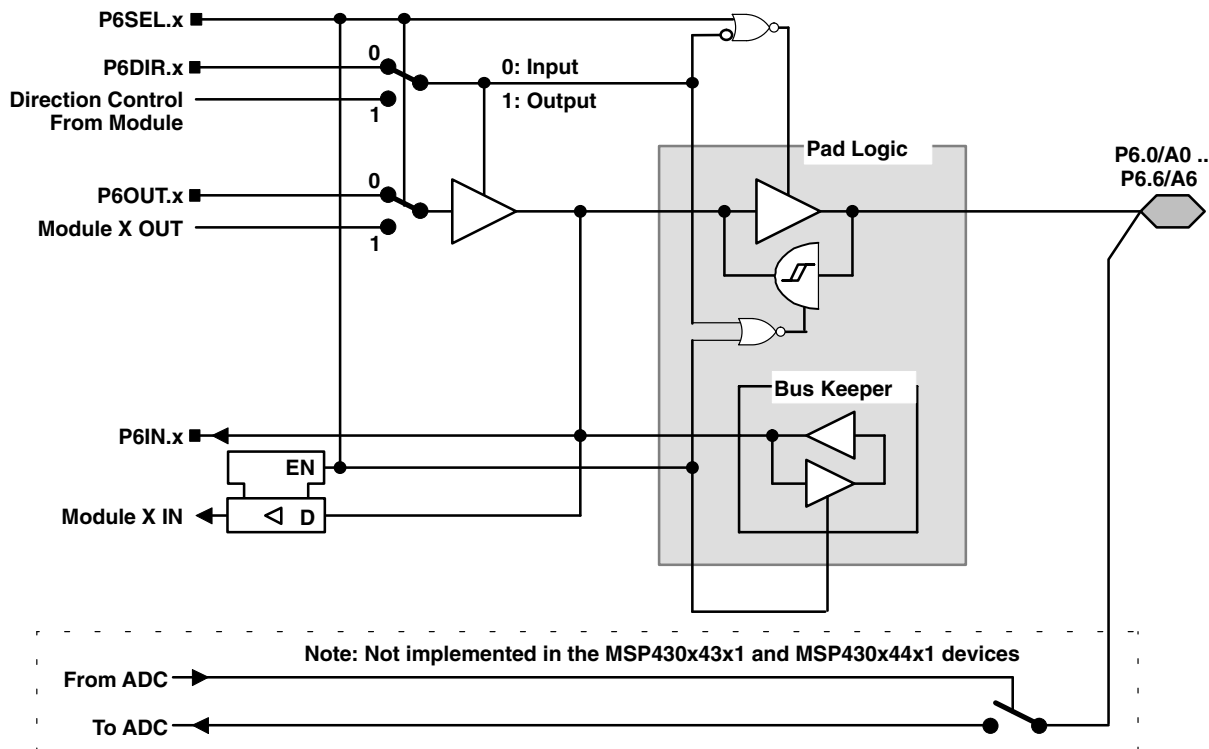

**x: Bit Identifier, 0 to 6 for Port P6**

NOTE: Analog signals applied to digital gates can cause current flow from the positive to the negative terminal. The throughput current flows if the analog signal is in the range of transitions 0→1 or 1→0. The value of the throughput current depends on the driving capability of the gate. For MSP430, it is approximately 100 μA.

Use P6SEL.x=1 to prevent throughput current. P6SEL.x should be set, even if the signal at the pin is not being used by the ADC12.

PnSel.x	PnDIR.x	Dir. Control From Module	PnOUT.x	Module X OUT	PnIN.x	Module X IN
P6Sel.0	P6DIR.0	P6DIR.0	P6OUT.0	DV <sub>SS</sub>	P6IN.0	unused
P6Sel.1	P6DIR.1	P6DIR.1	P6OUT.1	DV <sub>SS</sub>	P6IN.1	unused
P6Sel.2	P6DIR.2	P6DIR.2	P6OUT.2	DV <sub>SS</sub>	P6IN.2	unused
P6Sel.3	P6DIR.3	P6DIR.3	P6OUT.3	DV <sub>SS</sub>	P6IN.3	unused
P6Sel.4	P6DIR.4	P6DIR.4	P6OUT.4	DV <sub>SS</sub>	P6IN.4	unused
P6Sel.5	P6DIR.5	P6DIR.5	P6OUT.5	DV <sub>SS</sub>	P6IN.5	unused
P6Sel.6	P6DIR.6	P6DIR.6	P6OUT.6	DV <sub>SS</sub>	P6IN.6	unused

NOTE: The signal at pins P6.x/Ax is used by the 12-bit ADC module.

## APPLICATION INFORMATION

### port P6, P6.7, input/output with Schmitt trigger

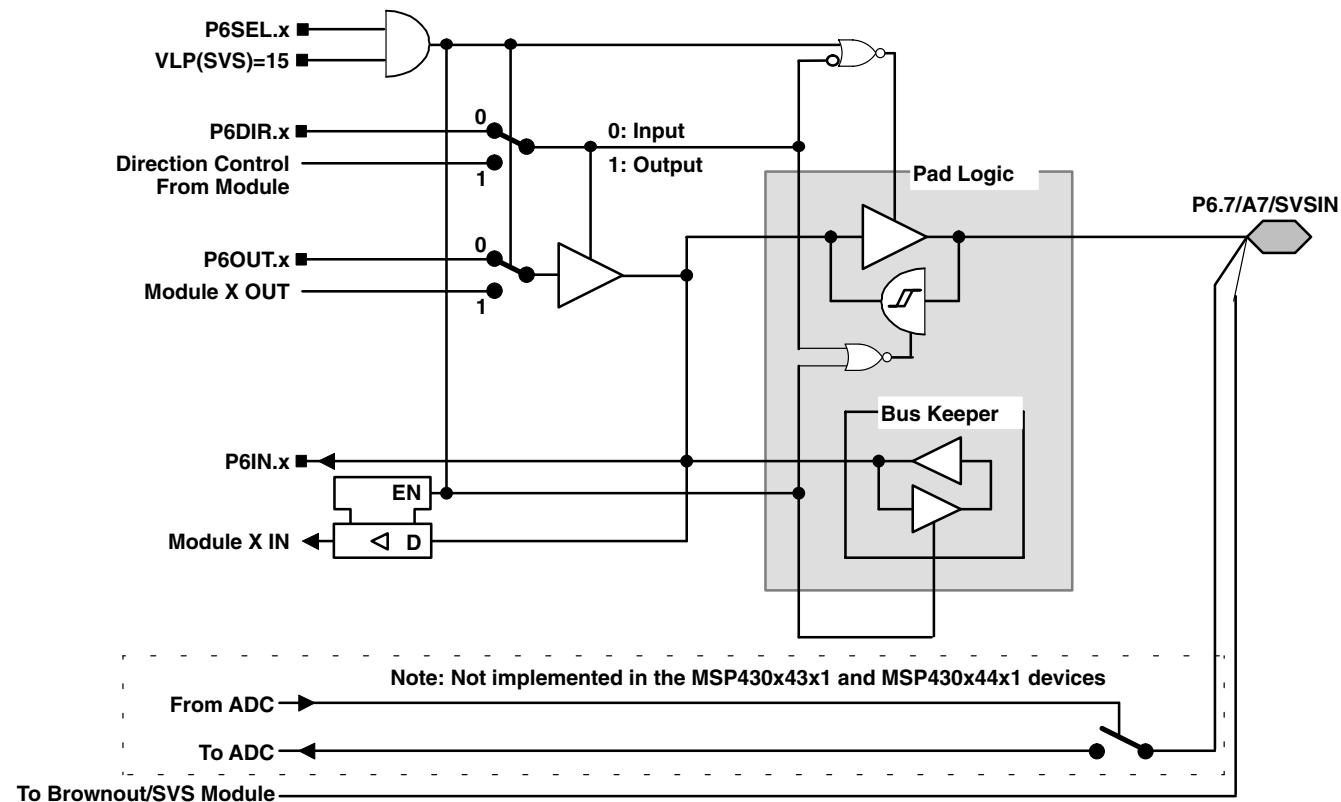

**x: Bit Identifier, 7 for Port P6**

NOTE: Analog signals applied to digital gates can cause current flow from the positive to the negative terminal. The throughput current flows if the analog signal is in the range of transitions 0→1 or 1→0. The value of the throughput current depends on the driving capability of the gate. For MSP430, it is approximately 100 μA.  
Use P6SEL.x=1 to prevent throughput current. P6SEL.x should be set, even if the signal at the pin is not being used by the ADC12.

PnSel.x	PnDIR.x	Dir. Control From Module	PnOUT.x	Module X OUT	PnIN.x	Module X IN
P6Sel.7	P6DIR.7	P6DIR.7	P6OUT.7	DV <sub>SS</sub>	P6IN.7	unused

NOTE: The signal at pins P6.x/Ax is used by the 12-bit ADC module.  
The signal at pin P6.7/A7/SVSIN is also connected to the input multiplexer in the module brownout/supply voltage supervisor.

# MSP430x43x1, MSP430x43x, MSP430x44x1, MSP430x44x MIXED SIGNAL MICROCONTROLLER

SLAS344G – JANUARY 2002 – REVISED OCTOBER 2009

## APPLICATION INFORMATION

JTAG pins TMS, TCK, TDI/TCLK, TDO/TDI, input/output with Schmitt trigger or output

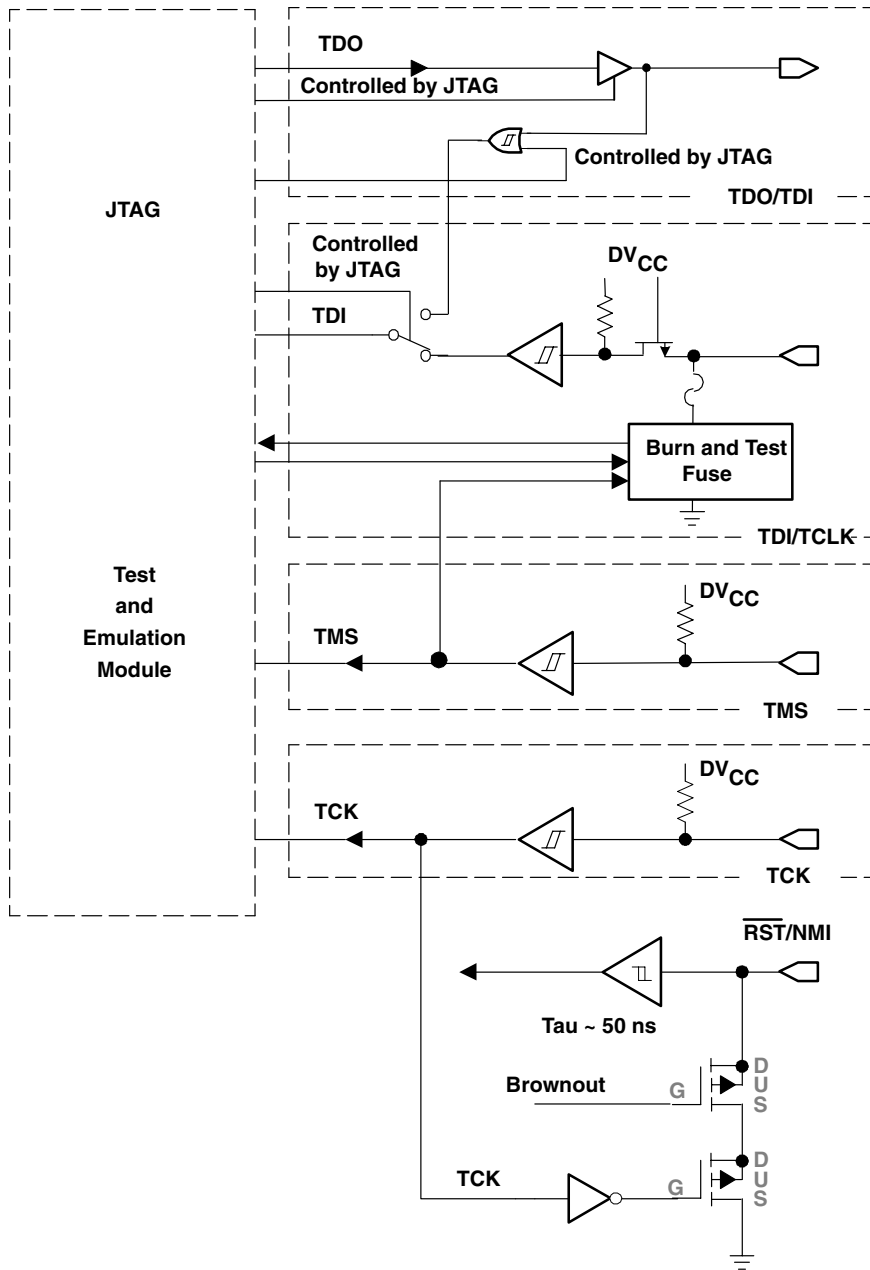

APPLICATION INFORMATION

JTAG fuse check mode

MSP430 devices that have the fuse on the TDI/TCLK terminal have a fuse check mode that tests the continuity of the fuse the first time the JTAG port is accessed after a power-on reset (POR). When activated, a fuse check current ( $I_{(TF)}$ ) of 1 mA at 3 V can flow from the TDI/TCLK pin to ground if the fuse is not burned. Care must be taken to avoid accidentally activating the fuse check mode and increasing overall system power consumption.

Activation of the fuse check mode occurs with the first negative edge on the TMS pin after power up or if the TMS is being held low during power up. The second positive edge on the TMS pin deactivates the fuse check mode. After deactivation, the fuse check mode remains inactive until another POR occurs. After each POR the fuse check mode has the potential to be activated.

The fuse check current only flows when the fuse check mode is active and the TMS pin is in a low state (see Figure 21). Therefore, the additional current flow can be prevented by holding the TMS pin high (default condition). The JTAG pins are terminated internally and therefore do not require external termination.

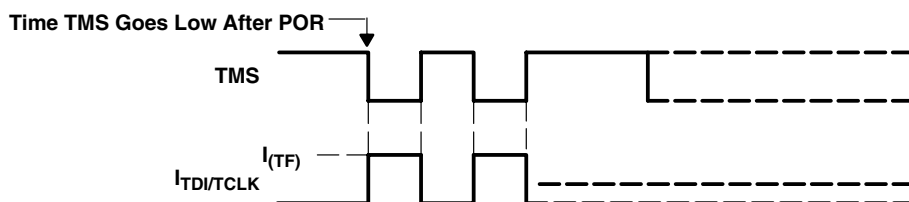

Figure 21. Fuse Check Mode Current MSP430x43x(1), MSP430x44x(1)

# MSP430x43x1, MSP430x43x, MSP430x44x1, MSP430x44x MIXED SIGNAL MICROCONTROLLER

SLAS344G – JANUARY 2002 – REVISED OCTOBER 2009

---

## Data Sheet Revision History

Literature Number	Summary
SLAS344E	Added MSP430F43x1 devices Updated functional block diagram (page 6) Clarified test conditions in recommended operating conditions table (page 27) Clarified test conditions in electrical characteristics table (page 28) Added Port 2 through Port 5 to leakage current table (page 29) Corrected y-axis unit on Figures 6 and 7; changed from V to mV (page 34) Clarified test conditions in USART0/USART1 table (page 40) Changed $t_{CPT}$ maximum value from 4 ms to 10 ms in Flash memory table (page 46)
SLAS344F	Added MSP430F43x1 devices in PZ (100 pin) package
SLAS344G	Added MSP430F44x1 devices

NOTE: Page and figure numbers refer to the respective document revision.



## Corrections to MSP430x43x, MSP430x43x1, MSP430x44x Data Sheet (SLAS344J)

---

---

---

Document Being Updated: MSP430x43x, MSP430x43x1, MSP430x44x Mixed Signal Microcontroller

Literature Number Being Updated: SLAS344J

### Page Change or Add

- 61 In both entries in the " $\overline{\text{Port}}/\text{LCD}$ " column of the table:  
0: LCDM < 40h should be changed to **0: LCDPx < 02h**.  
In note †:  
LCDM ≥ 40h should be changed to **LCDPx ≥ 02h**.
- 62 In top left of the figure:  
LCDM.5 should be changed to **bit 0 of LCDPx**, which is bit 5 of the LCDCTL register.  
LCDM.6 should be changed to **bit 1 of LCDPx**, which is bit 6 of the LCDCTL register.  
LCDM.7 should be changed to **bit 2 of LCDPx**, which is bit 7 of the LCDCTL register.
- 63 In top left of the figure:  
LCDM.7 should be changed to **bit 2 of LCDPx**, which is bit 7 of the LCDCTL register.
- 64 In the table at the bottom of the page:  
LCDM < 020h should be changed to **LCDPx < 01h**.  
LCDM ≥ 020h should be changed to **LCDPx ≥ 01h**.  
LCDM < 0E0h should be changed to **LCDPx < 07h**.  
LCDM ≥ 0E0h should be changed to **LCDPx ≥ 07h**.  
LCDM < 0C0h should be changed to **LCDPx < 06h**.  
LCDM ≥ 0C0h should be changed to **LCDPx ≥ 06h**.
- 65 In both entries in the " $\overline{\text{Port}}/\text{LCD}$ " column of the table:  
0: LCDM < 20h should be changed to **0: LCDPx < 01h**.

**PACKAGING INFORMATION**

Orderable Device	Status (1)	Package Type	Package Drawing	Pins	Package Qty	Eco Plan (2)	Lead/Ball Finish (6)	MSL Peak Temp (3)	Op Temp (°C)	Device Marking (4/5)	Samples
MSP430F4351IPN	ACTIVE	LQFP	PN	80	119	Green (RoHS & no Sb/Br)	CU NIPDAU	Level-3-260C-168 HR	-40 to 85	M430F4351	<a href="#">Samples</a>
MSP430F4351IPNR	ACTIVE	LQFP	PN	80	1000	Green (RoHS & no Sb/Br)	CU NIPDAU	Level-3-260C-168 HR	-40 to 85	M430F4351	<a href="#">Samples</a>
MSP430F4351IPZ	ACTIVE	LQFP	PZ	100	90	Green (RoHS & no Sb/Br)	CU NIPDAU	Level-3-260C-168 HR	-40 to 85	M430F4351	<a href="#">Samples</a>
MSP430F4351IPZR	ACTIVE	LQFP	PZ	100	1000	Green (RoHS & no Sb/Br)	CU NIPDAU	Level-3-260C-168 HR	-40 to 85	M430F4351	<a href="#">Samples</a>
MSP430F435IPN	ACTIVE	LQFP	PN	80	119	Green (RoHS & no Sb/Br)	CU NIPDAU	Level-3-260C-168 HR	-40 to 85	M430F435-80	<a href="#">Samples</a>
MSP430F435IPNR	ACTIVE	LQFP	PN	80	1000	Green (RoHS & no Sb/Br)	CU NIPDAU	Level-3-260C-168 HR	-40 to 85	M430F435-80	<a href="#">Samples</a>
MSP430F435IPZ	ACTIVE	LQFP	PZ	100	90	Green (RoHS & no Sb/Br)	CU NIPDAU	Level-3-260C-168 HR	-40 to 85	M430F435	<a href="#">Samples</a>
MSP430F435IPZR	ACTIVE	LQFP	PZ	100	1000	Green (RoHS & no Sb/Br)	CU NIPDAU	Level-3-260C-168 HR	-40 to 85	M430F435	<a href="#">Samples</a>
MSP430F4361IPN	ACTIVE	LQFP	PN	80	119	Green (RoHS & no Sb/Br)	CU NIPDAU	Level-3-260C-168 HR	-40 to 85	M430F4361	<a href="#">Samples</a>
MSP430F4361IPNR	ACTIVE	LQFP	PN	80	1000	Green (RoHS & no Sb/Br)	CU NIPDAU	Level-3-260C-168 HR	-40 to 85	M430F4361	<a href="#">Samples</a>
MSP430F4361IPZR	ACTIVE	LQFP	PZ	100	1000	Green (RoHS & no Sb/Br)	CU NIPDAU	Level-3-260C-168 HR	-40 to 85	M430F4361	<a href="#">Samples</a>
MSP430F436IPN	ACTIVE	LQFP	PN	80	119	Green (RoHS & no Sb/Br)	CU NIPDAU	Level-3-260C-168 HR	-40 to 85	M430F436-80	<a href="#">Samples</a>
MSP430F436IPNR	ACTIVE	LQFP	PN	80	1000	Green (RoHS & no Sb/Br)	CU NIPDAU	Level-3-260C-168 HR	-40 to 85	M430F436-80	<a href="#">Samples</a>
MSP430F436IPZ	ACTIVE	LQFP	PZ	100	90	Green (RoHS & no Sb/Br)	CU NIPDAU	Level-3-260C-168 HR	-40 to 85	M430F436	<a href="#">Samples</a>
MSP430F436IPZR	ACTIVE	LQFP	PZ	100	1000	Green (RoHS & no Sb/Br)	CU NIPDAU	Level-3-260C-168 HR	-40 to 85	M430F436	<a href="#">Samples</a>
MSP430F4371IPN	ACTIVE	LQFP	PN	80	119	Green (RoHS & no Sb/Br)	CU NIPDAU	Level-3-260C-168 HR	-40 to 85	M430F4371	<a href="#">Samples</a>
MSP430F4371IPNR	ACTIVE	LQFP	PN	80	1000	Green (RoHS & no Sb/Br)	CU NIPDAU	Level-3-260C-168 HR	-40 to 85	M430F4371	<a href="#">Samples</a>

Orderable Device	Status (1)	Package Type	Package Drawing	Pins	Package Qty	Eco Plan (2)	Lead/Ball Finish (6)	MSL Peak Temp (3)	Op Temp (°C)	Device Marking (4/5)	Samples
MSP430F4371IPZ	ACTIVE	LQFP	PZ	100	90	Green (RoHS & no Sb/Br)	CU NIPDAU	Level-3-260C-168 HR	-40 to 85	M430F4371	<a href="#">Samples</a>
MSP430F4371IPZR	ACTIVE	LQFP	PZ	100	1000	Green (RoHS & no Sb/Br)	CU NIPDAU	Level-3-260C-168 HR	-40 to 85	M430F4371	<a href="#">Samples</a>
MSP430F4371PN	ACTIVE	LQFP	PN	80	119	Green (RoHS & no Sb/Br)	CU NIPDAU	Level-3-260C-168 HR	-40 to 85	M430F437-80	<a href="#">Samples</a>
MSP430F4371PNR	ACTIVE	LQFP	PN	80	1000	Green (RoHS & no Sb/Br)	CU NIPDAU	Level-3-260C-168 HR	-40 to 85	M430F437-80	<a href="#">Samples</a>
MSP430F4371PZ	ACTIVE	LQFP	PZ	100	90	Green (RoHS & no Sb/Br)	CU NIPDAU	Level-3-260C-168 HR	-40 to 85	M430F437	<a href="#">Samples</a>
MSP430F4371PZR	ACTIVE	LQFP	PZ	100	1000	Green (RoHS & no Sb/Br)	CU NIPDAU	Level-3-260C-168 HR	-40 to 85	M430F437	<a href="#">Samples</a>
MSP430F4471PZ	ACTIVE	LQFP	PZ	100	90	Green (RoHS & no Sb/Br)	CU NIPDAU	Level-3-260C-168 HR	-40 to 85	M430F447	<a href="#">Samples</a>
MSP430F4471PZR	ACTIVE	LQFP	PZ	100	1000	Green (RoHS & no Sb/Br)	CU NIPDAU	Level-3-260C-168 HR	-40 to 85	M430F447	<a href="#">Samples</a>
MSP430F4481IPZ	ACTIVE	LQFP	PZ	100	90	Green (RoHS & no Sb/Br)	CU NIPDAU	Level-3-260C-168 HR	-40 to 85	M430F4481	<a href="#">Samples</a>
MSP430F4481IPZR	ACTIVE	LQFP	PZ	100	1000	Green (RoHS & no Sb/Br)	CU NIPDAU	Level-3-260C-168 HR	-40 to 85	M430F4481	<a href="#">Samples</a>
MSP430F448IPZ	ACTIVE	LQFP	PZ	100	90	Green (RoHS & no Sb/Br)	CU NIPDAU	Level-3-260C-168 HR	-40 to 85	M430F448	<a href="#">Samples</a>
MSP430F448IPZR	ACTIVE	LQFP	PZ	100	1000	Green (RoHS & no Sb/Br)	CU NIPDAU	Level-3-260C-168 HR	-40 to 85	M430F448	<a href="#">Samples</a>
MSP430F4491IPZ	ACTIVE	LQFP	PZ	100	90	Green (RoHS & no Sb/Br)	CU NIPDAU	Level-3-260C-168 HR	-40 to 85	M430F4491	<a href="#">Samples</a>
MSP430F4491IPZR	ACTIVE	LQFP	PZ	100	1000	Green (RoHS & no Sb/Br)	CU NIPDAU	Level-3-260C-168 HR	-40 to 85	M430F4491	<a href="#">Samples</a>
MSP430F449IPZ	ACTIVE	LQFP	PZ	100	90	Green (RoHS & no Sb/Br)	CU NIPDAU	Level-3-260C-168 HR	-40 to 85	M430F449	<a href="#">Samples</a>
MSP430F449IPZR	ACTIVE	LQFP	PZ	100	1000	Green (RoHS & no Sb/Br)	CU NIPDAU	Level-3-260C-168 HR	-40 to 85	M430F449 REV #	<a href="#">Samples</a>

(1) The marketing status values are defined as follows:

**ACTIVE:** Product device recommended for new designs.

**LIFEBUY:** TI has announced that the device will be discontinued, and a lifetime-buy period is in effect.

**NRND:** Not recommended for new designs. Device is in production to support existing customers, but TI does not recommend using this part in a new design.

---

**PREVIEW:** Device has been announced but is not in production. Samples may or may not be available.

**OBSELETE:** TI has discontinued the production of the device.

<sup>(2)</sup> **RoHS:** TI defines "RoHS" to mean semiconductor products that are compliant with the current EU RoHS requirements for all 10 RoHS substances, including the requirement that RoHS substance do not exceed 0.1% by weight in homogeneous materials. Where designed to be soldered at high temperatures, "RoHS" products are suitable for use in specified lead-free processes. TI may reference these types of products as "Pb-Free".

**RoHS Exempt:** TI defines "RoHS Exempt" to mean products that contain lead but are compliant with EU RoHS pursuant to a specific EU RoHS exemption.

**Green:** TI defines "Green" to mean the content of Chlorine (Cl) and Bromine (Br) based flame retardants meet JS709B low halogen requirements of  $\leq 1000$ ppm threshold. Antimony trioxide based flame retardants must also meet the  $\leq 1000$ ppm threshold requirement.

<sup>(3)</sup> MSL, Peak Temp. - The Moisture Sensitivity Level rating according to the JEDEC industry standard classifications, and peak solder temperature.

<sup>(4)</sup> There may be additional marking, which relates to the logo, the lot trace code information, or the environmental category on the device.

<sup>(5)</sup> Multiple Device Markings will be inside parentheses. Only one Device Marking contained in parentheses and separated by a "~" will appear on a device. If a line is indented then it is a continuation of the previous line and the two combined represent the entire Device Marking for that device.

<sup>(6)</sup> Lead/Ball Finish - Orderable Devices may have multiple material finish options. Finish options are separated by a vertical ruled line. Lead/Ball Finish values may wrap to two lines if the finish value exceeds the maximum column width.

**Important Information and Disclaimer:** The information provided on this page represents TI's knowledge and belief as of the date that it is provided. TI bases its knowledge and belief on information provided by third parties, and makes no representation or warranty as to the accuracy of such information. Efforts are underway to better integrate information from third parties. TI has taken and continues to take reasonable steps to provide representative and accurate information but may not have conducted destructive testing or chemical analysis on incoming materials and chemicals. TI and TI suppliers consider certain information to be proprietary, and thus CAS numbers and other limited information may not be available for release.

In no event shall TI's liability arising out of such information exceed the total purchase price of the TI part(s) at issue in this document sold by TI to Customer on an annual basis.

## TAPE AND REEL INFORMATION

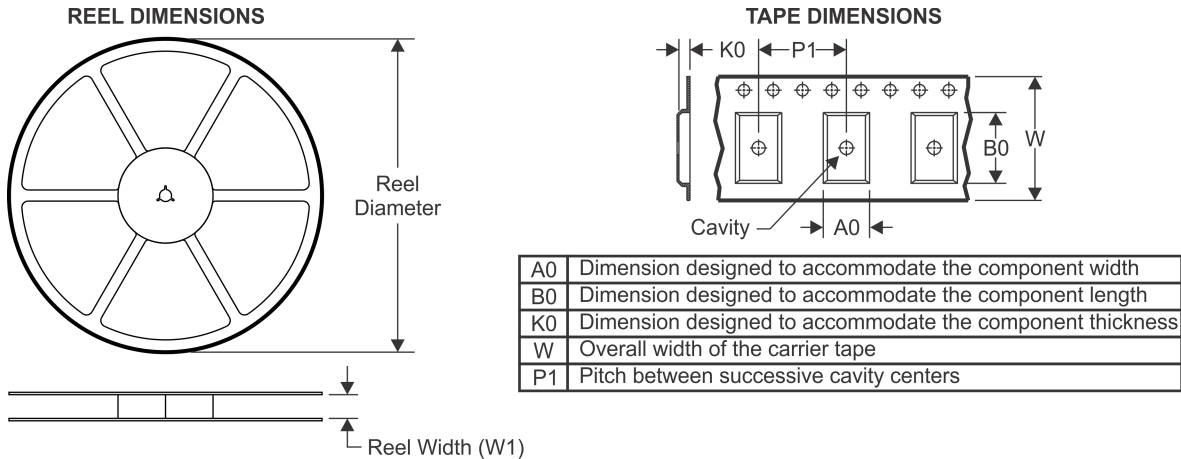

### QUADRANT ASSIGNMENTS FOR PIN 1 ORIENTATION IN TAPE

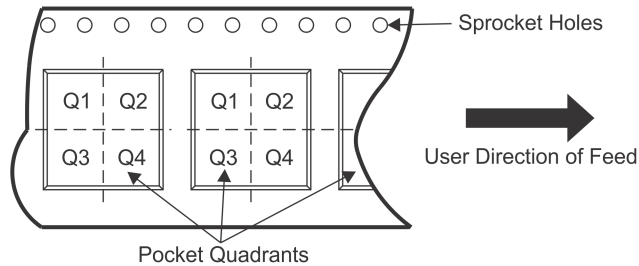

\*All dimensions are nominal

Device	Package Type	Package Drawing	Pins	SPQ	Reel Diameter (mm)	Reel Width W1 (mm)	A0 (mm)	B0 (mm)	K0 (mm)	P1 (mm)	W (mm)	Pin1 Quadrant
MSP430F4351IPNR	LQFP	PN	80	1000	330.0	24.4	15.0	15.0	2.1	20.0	24.0	Q2
MSP430F4351IPZR	LQFP	PZ	100	1000	330.0	24.4	17.0	17.0	2.1	20.0	24.0	Q2
MSP430F435IPNR	LQFP	PN	80	1000	330.0	24.4	15.0	15.0	2.1	20.0	24.0	Q2
MSP430F435IPZR	LQFP	PZ	100	1000	330.0	24.4	17.0	17.0	2.1	20.0	24.0	Q2
MSP430F4361IPNR	LQFP	PN	80	1000	330.0	24.4	15.0	15.0	2.1	20.0	24.0	Q2
MSP430F4361IPZR	LQFP	PZ	100	1000	330.0	24.4	17.0	17.0	2.1	20.0	24.0	Q2
MSP430F436IPNR	LQFP	PN	80	1000	330.0	24.4	15.0	15.0	2.1	20.0	24.0	Q2
MSP430F436IPZR	LQFP	PZ	100	1000	330.0	24.4	17.0	17.0	2.1	20.0	24.0	Q2
MSP430F4371IPNR	LQFP	PN	80	1000	330.0	24.4	15.0	15.0	2.1	20.0	24.0	Q2
MSP430F4371IPZR	LQFP	PZ	100	1000	330.0	24.4	17.0	17.0	2.1	20.0	24.0	Q2
MSP430F437IPNR	LQFP	PN	80	1000	330.0	24.4	15.0	15.0	2.1	20.0	24.0	Q2
MSP430F437IPZR	LQFP	PZ	100	1000	330.0	24.4	17.0	17.0	2.1	20.0	24.0	Q2
MSP430F447IPZR	LQFP	PZ	100	1000	330.0	24.4	17.0	17.0	2.1	20.0	24.0	Q2
MSP430F4481IPZR	LQFP	PZ	100	1000	330.0	24.4	17.0	17.0	2.1	20.0	24.0	Q2
MSP430F448IPZR	LQFP	PZ	100	1000	330.0	24.4	17.0	17.0	2.1	20.0	24.0	Q2
MSP430F4491IPZR	LQFP	PZ	100	1000	330.0	24.4	17.0	17.0	2.1	20.0	24.0	Q2
MSP430F449IPZR	LQFP	PZ	100	1000	330.0	24.4	17.0	17.0	2.1	20.0	24.0	Q2

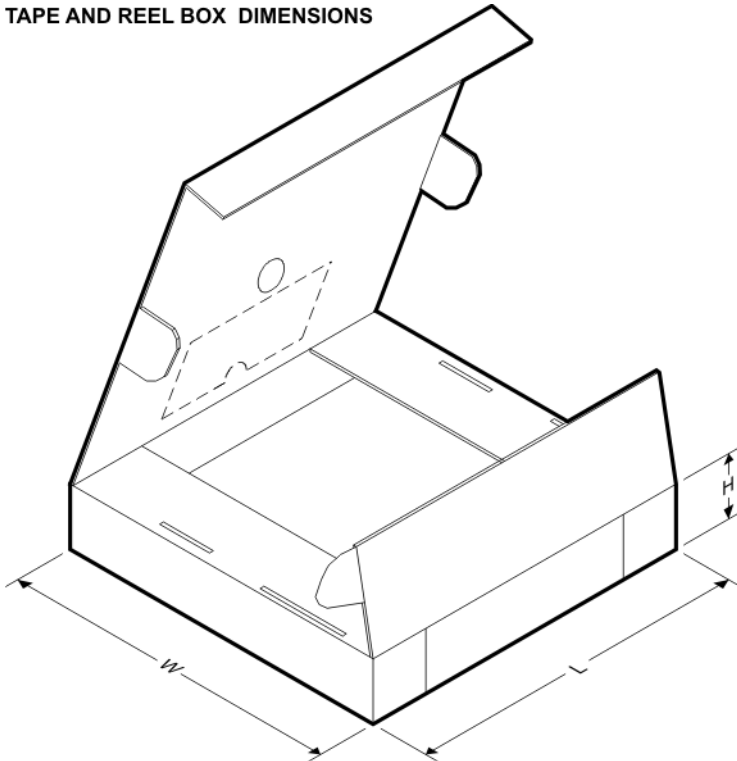
**TAPE AND REEL BOX DIMENSIONS**

\*All dimensions are nominal

Device	Package Type	Package Drawing	Pins	SPQ	Length (mm)	Width (mm)	Height (mm)
MSP430F4351IPNR	LQFP	PN	80	1000	367.0	367.0	45.0
MSP430F4351IPZR	LQFP	PZ	100	1000	367.0	367.0	45.0
MSP430F435IPNR	LQFP	PN	80	1000	367.0	367.0	45.0
MSP430F435IPZR	LQFP	PZ	100	1000	367.0	367.0	45.0
MSP430F4361IPNR	LQFP	PN	80	1000	367.0	367.0	45.0
MSP430F4361IPZR	LQFP	PZ	100	1000	367.0	367.0	45.0
MSP430F436IPNR	LQFP	PN	80	1000	367.0	367.0	45.0
MSP430F436IPZR	LQFP	PZ	100	1000	367.0	367.0	45.0
MSP430F4371IPNR	LQFP	PN	80	1000	367.0	367.0	45.0
MSP430F4371IPZR	LQFP	PZ	100	1000	367.0	367.0	45.0
MSP430F437IPNR	LQFP	PN	80	1000	367.0	367.0	45.0
MSP430F437IPZR	LQFP	PZ	100	1000	367.0	367.0	45.0
MSP430F447IPZR	LQFP	PZ	100	1000	367.0	367.0	45.0
MSP430F4481IPZR	LQFP	PZ	100	1000	367.0	367.0	45.0
MSP430F448IPZR	LQFP	PZ	100	1000	367.0	367.0	45.0
MSP430F4491IPZR	LQFP	PZ	100	1000	367.0	367.0	45.0
MSP430F449IPZR	LQFP	PZ	100	1000	367.0	367.0	45.0

PN (S-PQFP-G80)

PLASTIC QUAD FLATPACK

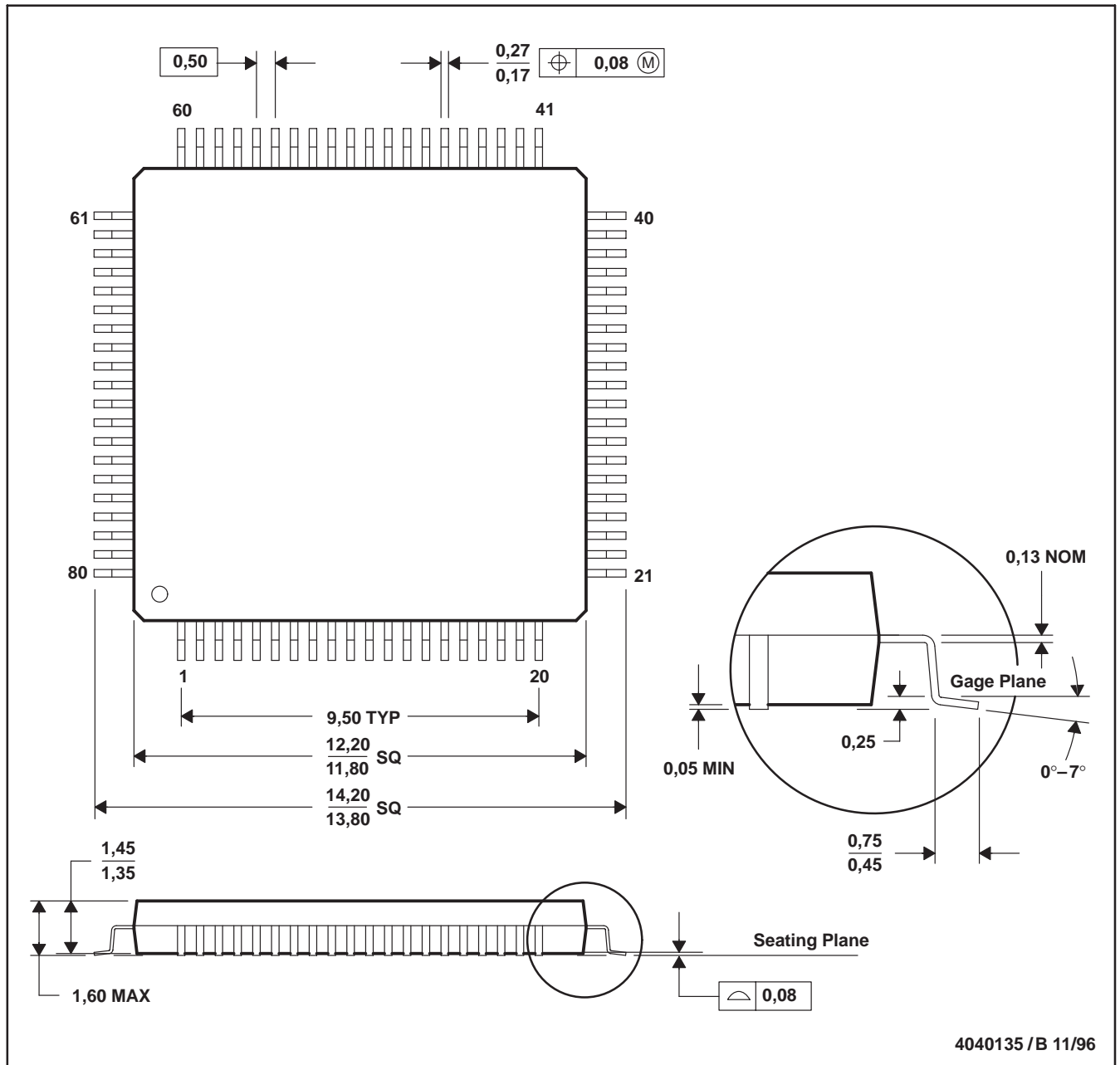

- NOTES: A. All linear dimensions are in millimeters.  
 B. This drawing is subject to change without notice.  
 C. Falls within JEDEC MS-026

PZ (S-PQFP-G100)

PLASTIC QUAD FLATPACK

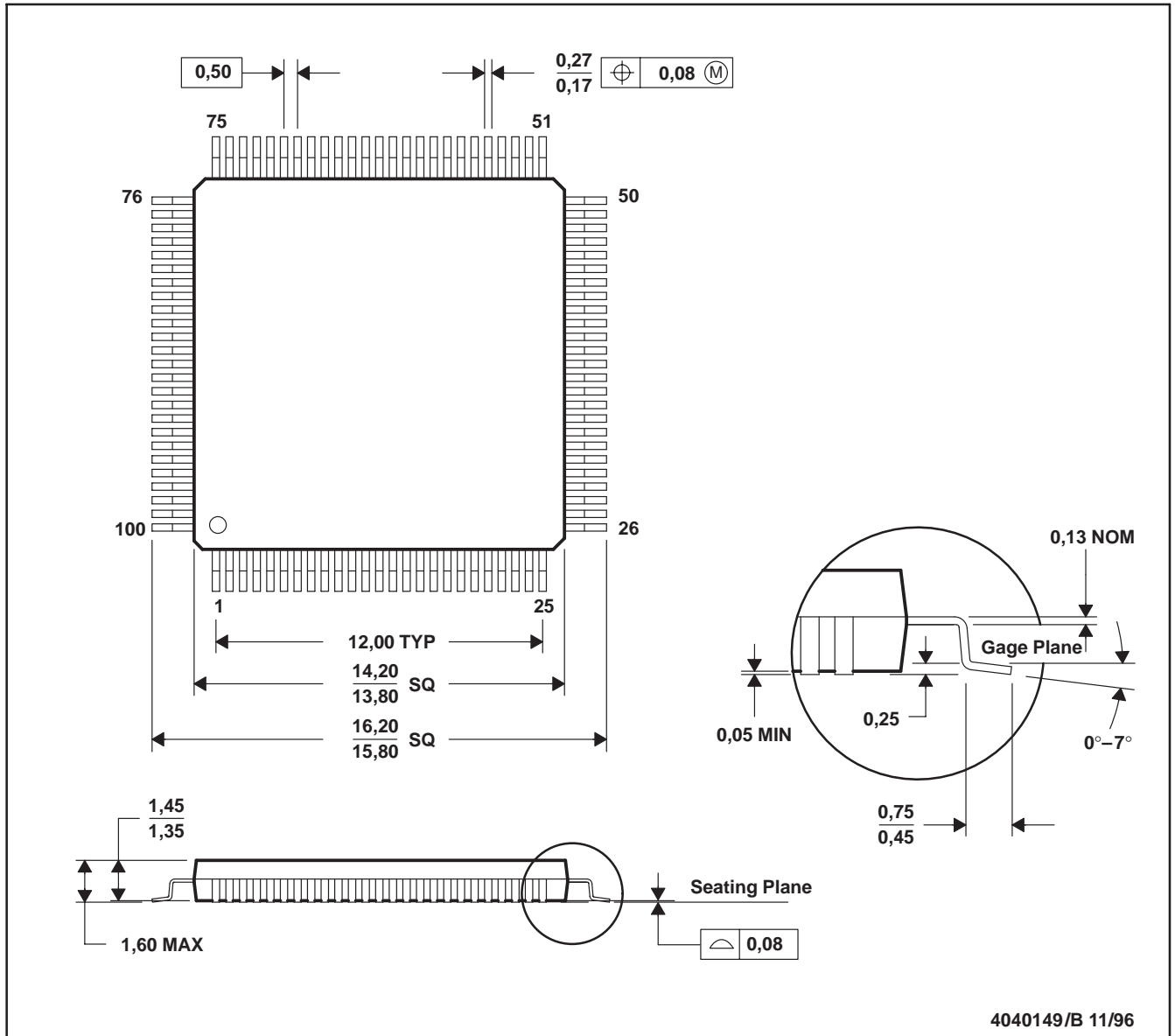

- NOTES: A. All linear dimensions are in millimeters.  
 B. This drawing is subject to change without notice.  
 C. Falls within JEDEC MS-026

PZ (S-PQFP-G100)

PLASTIC QUAD FLAT PACK

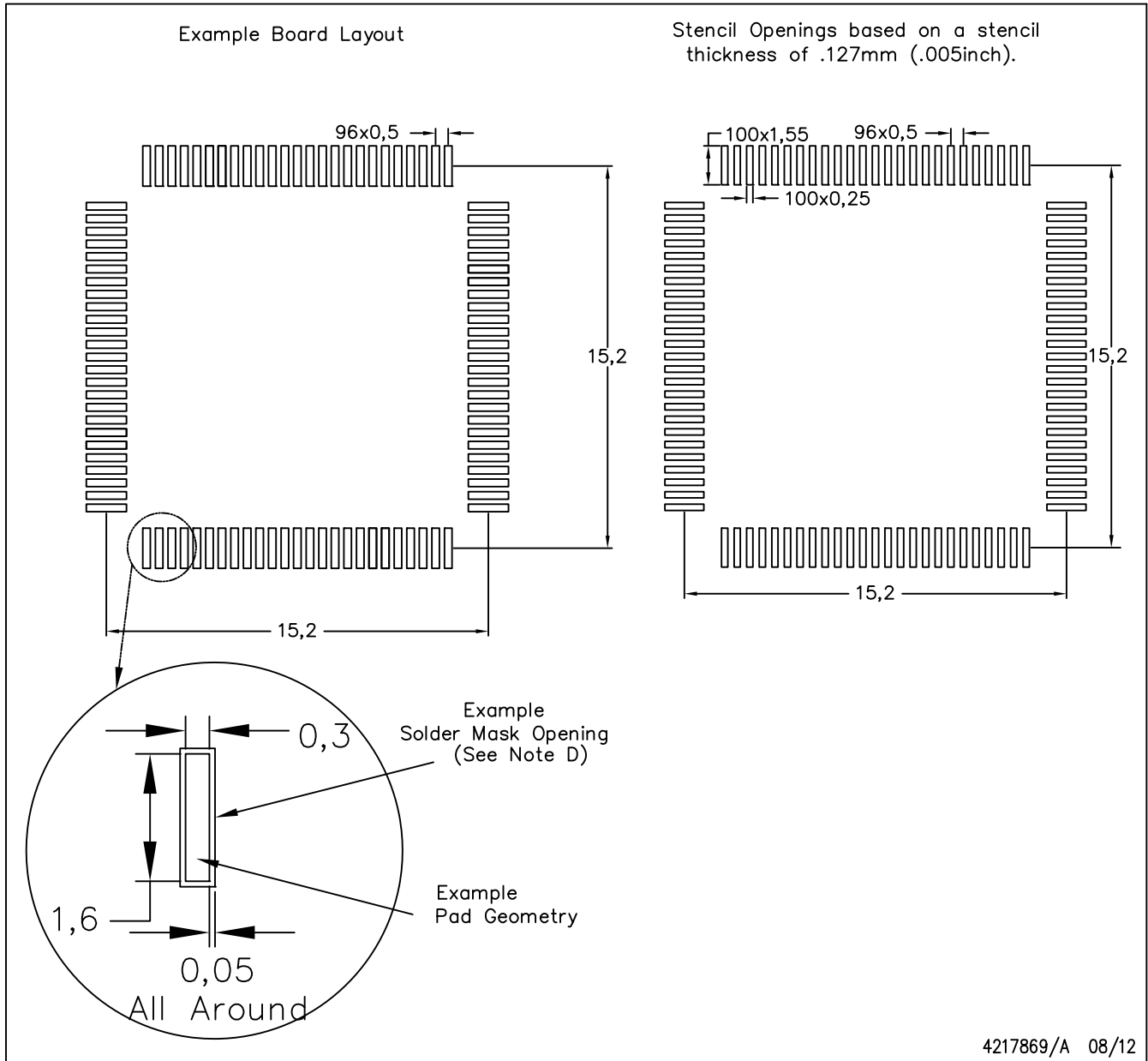

NOTES:

- A. All linear dimensions are in millimeters.
- B. This drawing is subject to change without notice.
- C. Laser cutting apertures with trapezoidal walls and also rounding corners will offer better paste release. Customers should contact their board assembly site for stencil design recommendations. Example stencil design based on a 50% volumetric metal load solder paste. Refer to IPC-7525 for other stencil recommendations.
- D. Customers should contact their board fabrication site for solder mask tolerances between and around signal pads.

## IMPORTANT NOTICE AND DISCLAIMER

TI PROVIDES TECHNICAL AND RELIABILITY DATA (INCLUDING DATASHEETS), DESIGN RESOURCES (INCLUDING REFERENCE DESIGNS), APPLICATION OR OTHER DESIGN ADVICE, WEB TOOLS, SAFETY INFORMATION, AND OTHER RESOURCES "AS IS" AND WITH ALL FAULTS, AND DISCLAIMS ALL WARRANTIES, EXPRESS AND IMPLIED, INCLUDING WITHOUT LIMITATION ANY IMPLIED WARRANTIES OF MERCHANTABILITY, FITNESS FOR A PARTICULAR PURPOSE OR NON-INFRINGEMENT OF THIRD PARTY INTELLECTUAL PROPERTY RIGHTS.

These resources are intended for skilled developers designing with TI products. You are solely responsible for (1) selecting the appropriate TI products for your application, (2) designing, validating and testing your application, and (3) ensuring your application meets applicable standards, and any other safety, security, or other requirements. These resources are subject to change without notice. TI grants you permission to use these resources only for development of an application that uses the TI products described in the resource. Other reproduction and display of these resources is prohibited. No license is granted to any other TI intellectual property right or to any third party intellectual property right. TI disclaims responsibility for, and you will fully indemnify TI and its representatives against, any claims, damages, costs, losses, and liabilities arising out of your use of these resources.

TI's products are provided subject to TI's Terms of Sale ([www.ti.com/legal/termsofsale.html](http://www.ti.com/legal/termsofsale.html)) or other applicable terms available either on [ti.com](http://ti.com) or provided in conjunction with such TI products. TI's provision of these resources does not expand or otherwise alter TI's applicable warranties or warranty disclaimers for TI products.

Mailing Address: Texas Instruments, Post Office Box 655303, Dallas, Texas 75265  
Copyright © 2019, Texas Instruments Incorporated

## Looking for pricing, stock, or lifecycle information?

Click below to explore more details on WIN SOURCE:

 [View MSP430F449IPZ on WIN SOURCE](#)

 [Texas Instruments](#) Information

## Optimize Your Supply Chain with WIN SOURCE Solutions

-  Global Sourcing Solution
-  Obsolete Management
-  Cost Control Management
-  Shortage Management
-  Alternative Solution
-  Excess Inventory Management