



**THE DATASHEET OF
MSP430F2132QRHBTEP**



MSP430F2132-EP Mixed Signal Microcontroller

1 Features

- Low Supply Voltage Range: 1.8 V to 3.6 V
- Ultra-Low Power Consumption
 - Active Mode: 250 μ A at 1 MHz, 2.2 V
 - Standby Mode: 0.7 μ A
 - Off Mode (RAM Retention): 0.1 μ A
- Ultra-Fast Wake-Up From Standby Mode in Less Than 1 μ s
- 16-Bit RISC Architecture, 62.5-ns Instruction Cycle Time
- Basic Clock Module Configurations
 - Internal Frequencies up to 16 MHz With Four Calibrated Frequencies to $\pm 1\%$
 - Internal Very-Low-Power Low-Frequency Oscillator
 - 32-kHz Crystal ⁽¹⁾
 - High-Frequency (HF) Crystal up to 16 MHz Resonator
 - External Digital Clock Source
 - External Resistor
- 16-Bit Timer0_A3 With Three Capture/Compare Registers
- 16-Bit Timer1_A2 With Two Capture/Compare Registers
- On-Chip Comparator for Analog Signal Compare Function or Slope Analog-to-Digital (A/D) Conversion
- 10-Bit 200-ksps A/D Converter With Internal Reference, Sample-and-Hold, Autoscan, and Data Transfer Controller
- Universal Serial Communication Interface
 - Enhanced UART Supporting Auto-Baudrate Detection (LIN)
 - IrDA Encoder and Decoder
 - Synchronous SPI
 - I²C™
- Brownout Detector

(1) Crystal oscillator cannot be operated beyond 105°C.

- Serial Onboard Programming, No External Programming Voltage Needed, Programmable Code Protection by Security Fuse
- Bootstrap Loader
- On-Chip Emulation Module
- 8KB + 256B Flash Memory
- 512B RAM
- Available in a 32-Pin QFN (RHB) Package
- For Complete Module Descriptions, See the *MSP430x2xx Family User's Guide*, Literature Number [SLAU144](#)

2 Applications

- Controlled Baseline
- One Assembly and Test Site
- One Fabrication Site
- Available in Extended (–40°C to 125°C) Temperature Range ⁽²⁾
- Extended Product Life Cycle
- Extended Product-Change Notification
- Product Traceability

3 Description

The MSP430F2132 is an ultra-low-power microcontroller. The architecture, combined with five low-power modes, is optimized to achieve extended battery life in portable measurement applications. The device features a powerful 16-bit RISC CPU, 16-bit registers, and constant generators that contribute to maximum code efficiency. The digitally controlled oscillator (DCO) allows wake-up from low-power modes to active mode in less than 1 μ s.

The MSP430F2132 has two built-in 16-bit timers, a fast 10-bit A/D converter with integrated reference and a data transfer controller (DTC), a comparator, built-in communication capability using the universal serial communication interface, and up to 24 I/O pins.

(2) Custom temperature ranges available



3.1 Development Tool Support

All MSP430 microcontrollers include an Embedded Emulation Module (EEM) that allows advanced debugging and programming through easy-to-use development tools. Recommended hardware options include:

- Debugging and Programming Interface
 - MSP-FET430UIF (USB)
 - MSP-FET430PIF (Parallel Port)
- Debugging and Programming Interface with Target Board
 - MSP-FET430U28 (PW package)
- Production Programmer
 - MSP-GANG430

3.2 Device Pinout, RHB Package

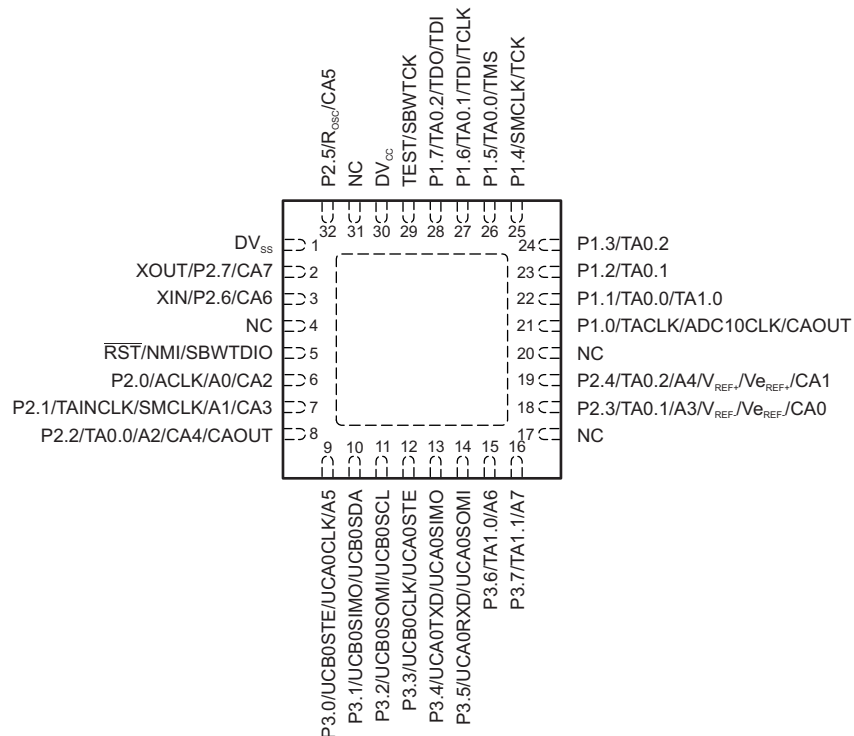

3.3 Functional Block Diagram

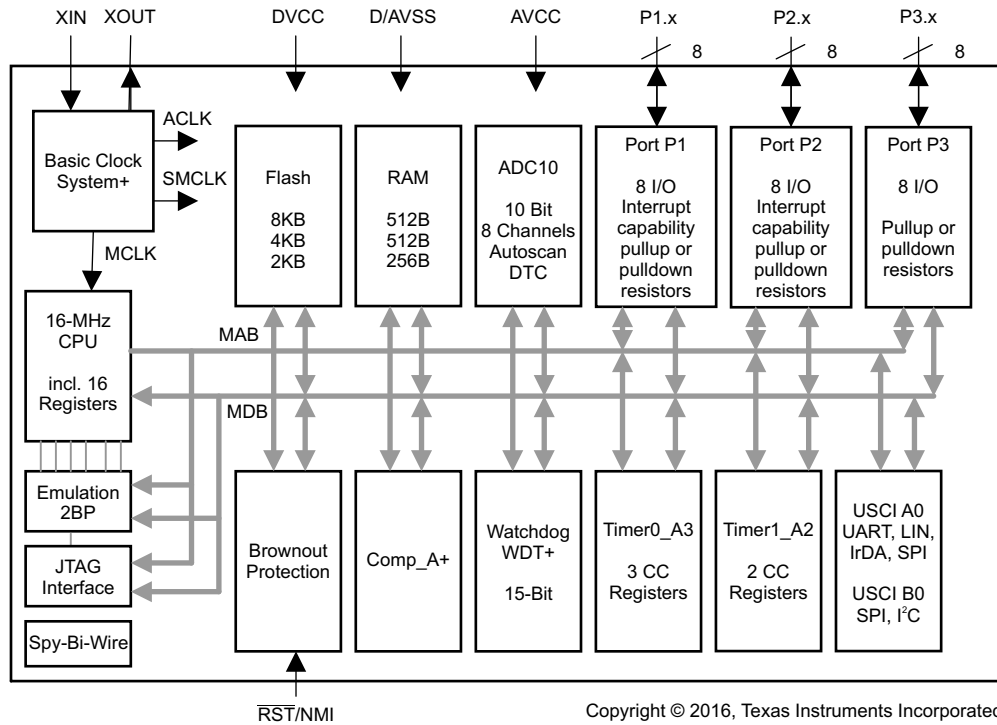

Functional Block Diagram (continued)**Terminal Functions**

| TERMINAL | | I/O | DESCRIPTION |
|--|-----|-----|--|
| NAME | NO. | | |
| P1.0/TACLK/ADC10CLK/CAOUT | 21 | I/O | General-purpose digital I/O pin Timer0_A3, clock signal TACLK input Timer1_A2, clock signal TACLK input ADC10, conversion clock Comparator_A+ output |
| P1.1/TA0.0/TA1.0 | 22 | I/O | General-purpose digital I/O pin Timer0_A3, capture: CCI0A input, compare: Out0 Output Timer1_A2, capture: CCI0A input |
| P1.2/TA0.1 | 23 | I/O | General-purpose digital I/O pin Timer0_A3, capture: CCI1A input, compare: Out1 Output |
| P1.3/TA0.2 | 24 | I/O | General-purpose digital I/O pin Timer0_A3, capture: CCI2A input, compare: Out2 Output |
| P1.4/SMCLK/TCK | 25 | I/O | General-purpose digital I/O pin SMCLK signal output Test Clock input for device programming and test |
| P1.5/TA0.0/TMS | 26 | I/O | General-purpose digital I/O pin Timer0_A3, compare: Out0 Output JTAG test mode select, input terminal for device programming and test |
| P1.6/TA0.1/TDI/TCLK | 27 | I/O | General-purpose digital I/O pin Timer0_A3, compare: Out1 Output JTAG test data input or test clock input in programming an test |
| P1.7/TA0.2/TDO/TDI | 28 | I/O | General-purpose digital I/O pin Timer0_A3, compare: Out2 Output JTAG test data output terminal or test data input in programming an test |
| P2.0/ACLK/A0/CA2 | 6 | I/O | General-purpose digital I/O pin ACLK signal output ADC10 analog input A0 Comparator_A+ input |
| P2.1/TAINCLK/SMCLK/A1/CA3 | 7 | I/O | General-purpose digital I/O pin SMCLK signal output Timer0_A3, clock signal TACLK input Timer1_A2, clock signal TACLK input ADC10 analog input A1 Comparator_A+ input |
| P2.2/TA0.0/A2/CA4/CAOUT | 8 | I/O | General-purpose digital I/O pin Timer0_A3, capture: CCI0B input, compare: Out0 Output ADC10 analog input A2 Comparator_A+ input Comparator_A+ output |
| P2.3/TA0.1/A3/V _{REF-} /V _{eREF-} /CA0 | 18 | I/O | General-purpose digital I/O pin Timer0_A3, compare: Out1 Output ADC10 analog input A3 / negative reference Comparator_A+ input |

Functional Block Diagram (continued)
Terminal Functions (continued)

| TERMINAL | | I/O | DESCRIPTION |
|--|---------------|-----|---|
| NAME | NO. | | |
| P2.4/TA0.2/A4/V _{REF+} /V _{eREF+} /CA1 | 19 | I/O | General-purpose digital I/O pin Timer0_A3, compare: Out2 Output ADC10 analog input A4 / positive reference Comparator_A+ input |
| XIN/P2.6/CA6 | 3 | I/O | Input terminal of crystal oscillator General-purpose digital I/O pin Comparator_A+ input |
| XOUT/P2.7/CA7 | 2 | I/O | Output terminal of crystal oscillator General-purpose digital I/O pin Comparator_A+ input |
| P3.0/UCB0STE/UCA0CLK/A5 | 9 | I/O | General-purpose digital I/O pin USCI_B0 slave transmit enable/USCI_A0 clock input/output ADC10 analog input A5 |
| P3.1/UCB0SIMO/UCB0SDA | 10 | I/O | General-purpose digital I/O pin USCI_B0 slave in/master out (SPI mode), SDA I2C data (I2C mode) |
| P3.2/UCB0SOMI/UCB0SCL | 11 | I/O | General-purpose digital I/O pin USCI_B0 slave out/master in (SPI mode), SCL I2C clock (I2C mode) |
| P3.3/UCB0CLK/UCA0STE | 12 | I/O | General-purpose digital I/O USCI_B0 clock input/output, USCI_A0 slave transmit enable |
| P3.4/UCA0TXD/UCA0SIMO | 13 | I/O | General-purpose digital I/O pin USCI_A0 transmit data output in UART mode, slave data in/master out in SPI mode |
| P3.5/UCA0RXD/UCA0SOMI | 14 | I/O | General-purpose digital I/O pin USCI_A0 receive data input (UART mode), slave data out/master in (SPI mode) |
| P3.6/TA1.0/A6 | 15 | I/O | General-purpose digital I/O pin Timer1_A2, capture: CCI0B input, compare: Out0 Output ADC10 analog input A6 |
| P3.7/TA1.1/A7 | 16 | I/O | General-purpose digital I/O pin Timer1_A2, capture: CCI1A input, compare: Out1 Output ADC10 analog input A7 |
| $\overline{\text{RST}}$ /NMI/SBWDIO | 5 | I | Reset or nonmaskable interrupt input Spy-Bi-Wire test data input/output during programming and test |
| TEST/SBWTCK | 29 | I | Selects test mode for JTAG pins on Port 1. The device protection fuse is connected to TEST. |
| P2.5/R _{OSC} /CA5 | 32 | I/O | General-purpose digital I/O pin Input for external resistor defining the DCO nominal frequency Comparator_A+ input |
| DV _{CC} | 30 | | Digital supply voltage |
| DV _{SS} | 1 | | Digital supply voltage |
| NC | 4, 17, 20, 31 | | Not connected internally. Connection to V _{SS} is recommended. |
| QFN Pad | Pad | | QFN package pad (RHB, RTV packages). Connection to DV _{SS} is recommended. |

4 Short-Form Description

4.1 CPU

The MSP430F2132 CPU has a 16-bit RISC architecture that is highly transparent to the application. All operations, other than program-flow instructions, are performed as register operations in conjunction with seven addressing modes for source operand and four addressing modes for destination operand.

The CPU is integrated with 16 registers that provide reduced instruction execution time. The register-to-register operation execution time is one cycle of the CPU clock.

Four of the registers, R0 to R3, are dedicated as program counter, stack pointer, status register, and constant generator respectively. The remaining registers are general-purpose registers.

Peripherals are connected to the CPU using data, address, and control buses and can be handled with all instructions.

4.2 Instruction Set

The instruction set consists of 51 instructions with three formats and seven address modes. Each instruction can operate on word and byte data. [Table 1](#) shows examples of the three types of instruction formats; [Table 2](#) shows the address modes.

| | |
|--------------------------|-----------|
| Program Counter | PC/R0 |
| Stack Pointer | SP/R1 |
| Status Register | SR/CG1/R2 |
| Constant Generator | CG2/R3 |
| General-Purpose Register | R4 |
| General-Purpose Register | R5 |
| General-Purpose Register | R6 |
| General-Purpose Register | R7 |
| General-Purpose Register | R8 |
| General-Purpose Register | R9 |
| General-Purpose Register | R10 |
| General-Purpose Register | R11 |
| General-Purpose Register | R12 |
| General-Purpose Register | R13 |
| General-Purpose Register | R14 |
| General-Purpose Register | R15 |

Table 1. Instruction Word Formats

| INSTRUCTION FORMAT | EXAMPLE | OPERATION |
|---|-----------|---|
| Dual operands, source-destination | ADD R4,R5 | $R4 + R5 \rightarrow R5$ |
| Single operands, destination only | CALL R8 | $PC \rightarrow (TOS), R8 \rightarrow PC$ |
| Relative jump, unconditional or conditional | JNE | Jump-on-equal bit = 0 |

Table 2. Address Mode Descriptions

| ADDRESS MODE | S ⁽¹⁾ | D ⁽²⁾ | SYNTAX | EXAMPLE | OPERATION |
|------------------------|------------------|------------------|-----------------|------------------|-------------------------------|
| Register | ✓ | ✓ | MOV Rs,Rd | MOV R10,R11 | R10 → R11 |
| Indexed | ✓ | ✓ | MOV X(Rn),Y(Rm) | MOV 2(R5),6(R6) | M(2+R5) → M(6+R6) |
| Symbolic (PC relative) | ✓ | ✓ | MOV EDE,TONI | | M(EDE) → M(TONI) |
| Absolute | ✓ | ✓ | MOV &MEM,&TCDAT | | M(MEM) → M(TCDAT) |
| Indirect | ✓ | | MOV @Rn,Y(Rm) | MOV @R10,Tab(R6) | M(R10) → M(Tab+R6) |
| Indirect autoincrement | ✓ | | MOV @Rn+,Rm | MOV @R10+,R11 | M(R10) → R11 R10 + 2 → R10 |
| Immediate | ✓ | | MOV #X,TONI | MOV #45,TONI | #45 → M(TONI) |

(1) S = source

(2) D = destination

4.3 Operating Modes

The MSP430F2132 has one active mode and five software-selectable low-power modes of operation. An interrupt event can wake up the device from any of the five low-power modes, service the request, and restore back to the low-power mode on return from the interrupt program.

The following six operating modes can be configured by software:

- Active mode (AM)
 - All clocks are active.
- Low-power mode 0 (LPM0)
 - CPU is disabled.
 - ACLK and SMCLK remain active. MCLK is disabled.
- Low-power mode 1 (LPM1)
 - CPU is disabled. ACLK and SMCLK remain active. MCLK is disabled.
 - DCO dc-generator is disabled if DCO not used in active mode.
- Low-power mode 2 (LPM2)
 - CPU is disabled.
 - MCLK and SMCLK are disabled.
 - DCO dc-generator remains enabled.
 - ACLK remains active.
- Low-power mode 3 (LPM3)
 - CPU is disabled.
 - MCLK and SMCLK are disabled.
 - DCO dc-generator is disabled.
 - ACLK remains active.
- Low-power mode 4 (LPM4)
 - CPU is disabled.
 - ACLK is disabled.
 - MCLK and SMCLK are disabled.
 - DCO dc-generator is disabled.
 - Crystal oscillator is stopped.

4.4 Interrupt Vector Addresses

The interrupt vectors and the power-up starting address are located in the address range of 0xFFFF to 0xFFC0. The vector contains the 16-bit address of the appropriate interrupt handler instruction sequence.

If the reset vector (located at address 0xFFFFE) contains 0xFFFF (for example, if flash is not programmed), the CPU goes into LPM4 immediately after power up.

Table 3. Interrupt Vector Addresses

| INTERRUPT SOURCE | INTERRUPT FLAG | SYSTEM INTERRUPT | WORD ADDRESS | PRIORITY |
|---|--|---|------------------|-----------------|
| Power-up External reset Watchdog Flash key violation PC out of range ⁽²⁾ | PORIFG RSTIFG WDTIFG KEYV ⁽¹⁾ | Reset | 0xFFFFE | 31, highest |
| NMI Oscillator fault Flash memory access violation | NMIIFG OFIFG ACCVIFG ⁽¹⁾⁽³⁾ | (Non)maskable (Non)maskable (Non)maskable | 0xFFFC | 30 |
| Timer1_A2 | TA1CCR0 CCIFG ⁽⁴⁾ | Maskable | 0xFFFA | 29 |
| Timer1_A2 | TA1CCR1 CCIFG, TA1CTL TAIFG ⁽¹⁾⁽⁴⁾ | Maskable | 0xFF8 | 28 |
| Comparator_A+ | CAIFG | Maskable | 0xFFF6 | 27 |
| Watchdog timer | WDTIFG | Maskable | 0xFFF4 | 26 |
| Timer0_A3 | TA0CCR0 CCIFG ⁽⁴⁾ | Maskable | 0xFFF2 | 25 |
| Timer0_A3 | TA0CCR1 CCIFG, TA0CCR2 CCIFG, TA0CTL TAIFG ⁽¹⁾⁽⁴⁾ | Maskable | 0xFFF0 | 24 |
| USCI_A0/USCI_B0 receive USCI_B0 I2C status | UCA0RXIFG, UCB0RXIFG ⁽¹⁾⁽⁵⁾ | Maskable | 0xFFEE | 23 |
| USCI_A0/USCI_B0 transmit USCI_B0 I2C receive/transmit | UCA0TXIFG, UCB0TXIFG ⁽¹⁾⁽⁶⁾ | Maskable | 0xFFEC | 22 |
| ADC10 | ADC10IFG ⁽⁴⁾ | Maskable | 0xFFEA | 21 |
| | | | 0xFFE8 | 20 |
| I/O port P2 (eight flags) | P2IFG.0 to P2IFG.7 ⁽¹⁾⁽⁴⁾ | Maskable | 0xFFE6 | 19 |
| I/O port P1 (eight flags) | P1IFG.0 to P1IFG.7 ⁽¹⁾⁽⁴⁾ | Maskable | 0xFFE4 | 18 |
| | | | 0xFFE2 | 17 |
| | | | 0xFFE0 | 16 |
| See ⁽⁷⁾ | | | 0xFFDE | 15 |
| See ⁽⁸⁾ | | | 0xFFDC to 0xFFC0 | 14 to 0, lowest |

- (1) Multiple source flags
- (2) A reset is generated if the CPU tries to fetch instructions from within the module register memory address range (0x0000 to 0x01FF) or from within unused address range.
- (3) (non)-maskable: the individual interrupt-enable bit can disable an interrupt event, but the general interrupt enable cannot. Nonmaskable: neither the individual nor the general interrupt-enable bit will disable an interrupt event.
- (4) Interrupt flags are located in the module.
- (5) In SPI mode: UCB0RXIFG. In I2C mode: UCALIFG, UCNACKIFG, ICSTTIFG, UCSTPIFG
- (6) In UART/SPI mode: UCB0TXIFG. In I2C mode: UCB0RXIFG, UCB0TXIFG
- (7) This location is used as bootstrap loader security key (BSLSKEY).
A 0xAA55 at this location disables the BSL completely.
A zero (0x0) disables the erasure of the flash if an invalid password is supplied.
- (8) The interrupt vectors at addresses 0xFFDC to 0xFFC0 are not used in this device and can be used for regular program code if necessary.

4.5 Special Function Registers

Most interrupt and module enable bits are collected into the lowest address space. Special function register bits not allocated to a functional purpose are not physically present in the device. Simple software access is provided with this arrangement.

Legend









| | |
|---|---|
| rw | Bit can be read and written. |
| rw-0, 1 | Bit can be read and written. It is Reset or Set by PUC. |
| rw-(0), (1) | Bit can be read and written. It is Reset or Set by POR. |
|  | SFR bit is not present in device. |

Table 4. Interrupt Enable 1

| Address | 7 | 6 | 5 | 4 | 3 | 2 | 1 | 0 |
|---------|---|---|--------|-------|--|---|------|-------|
| 00h |  |  | ACCVIE | NMIIE |  |  | OFIE | WDTIE |
| | | | rw-0 | rw-0 | | | rw-0 | rw-0 |



| | |
|--------|--|
| WDTIE | Watchdog timer interrupt enable. Inactive if watchdog mode is selected. Active if watchdog timer is configured in interval timer mode. |
| OFIE | Oscillator fault interrupt enable |
| NMIIE | (Non)maskable interrupt enable |
| ACCVIE | Flash access violation interrupt enable |

Table 5. Interrupt Enable 2

| Address | 7 | 6 | 5 | 4 | 3 | 2 | 1 | 0 |
|---------|---|---|---|---|----------|----------|----------|----------|
| 01h |  |  |  |  | UCB0TXIE | UCB0RXIE | UCA0TXIE | UCA0RXIE |
| | | | | | rw-0 | rw-0 | rw-0 | rw-0 |





| | |
|----------|-----------------------------------|
| UCA0RXIE | USCI_A0 receive-interrupt enable |
| UCA0TXIE | USCI_A0 transmit-interrupt enable |
| UCB0RXIE | USCI_B0 receive-interrupt enable |
| UCB0TXIE | USCI_B0 transmit-interrupt enable |

Table 6. Interrupt Flag Register 1

| Address | 7 | 6 | 5 | 4 | 3 | 2 | 1 | 0 |
|---------|---|---|---|--------|--------|--------|-------|--------|
| 02h |  |  |  | NMIIFG | RSTIFG | PORIFG | OFIFG | WDTIFG |
| | | | | rw-0 | rw-(0) | rw-(1) | rw-1 | rw-(0) |

| | |
|--------|--|
| WDTIFG | Set on watchdog timer overflow (in watchdog mode) or security key violation. Reset on V _{CC} power-up or a reset condition at \overline{RST}/NMI pin in reset mode. |
| OFIFG | Flag set on oscillator fault |
| RSTIFG | External reset interrupt flag. Set on a reset condition at \overline{RST}/NMI pin in reset mode. Reset on V _{CC} power up. |
| PORIFG | Power-on reset interrupt flag. Set on V _{CC} power up. |
| NMIIFG | Set via \overline{RST}/NMI pin |

Table 7. Interrupt Flag Register 2

| Address | 7 | 6 | 5 | 4 | 3 | 2 | 1 | 0 |
|---------|---|---|---|---|-----------|-----------|-----------|-----------|
| 03h |  |  |  |  | UCB0TXIFG | UCB0RXIFG | UCA0TXIFG | UCA0RXIFG |
| | | | | | rw-1 | rw-0 | rw-1 | rw-0 |

| | |
|-----------|---------------------------------|
| UCA0RXIFG | USCI_A0 receive-interrupt flag |
| UCA0TXIFG | USCI_A0 transmit-interrupt flag |
| UCB0RXIFG | USCI_B0 receive-interrupt flag |
| UCB0TXIFG | USCI_B0 transmit-interrupt flag |

4.6 Memory Organization

Table 8. Memory Organization

| | | MSP430F2112 | MSP430F2122 | MSP430F2132 |
|------------------------|-----------|-------------------|-------------------|-------------------|
| Memory | Size | 2 KB | 4 KB | 8 KB |
| Main: interrupt vector | Flash | 0xFFFF to 0xFFC0 | 0xFFFF to 0xFFC0 | 0xFFFF to 0xFFC0 |
| Main: code memory | Flash | 0xFFFF to 0xF800 | 0xFFFF to 0xF000 | 0xFFFF to 0xE000 |
| Information memory | Size | 256 Byte | 256 Byte | 256 Byte |
| | Flash | 0x10FFh to 0x1000 | 0x10FFh to 0x1000 | 0x10FFh to 0x1000 |
| Boot memory | Size | 1 KB | 1 KB | 1 KB |
| | ROM | 0x0FFF to 0x0C00 | 0x0FFF to 0x0C00 | 0x0FFF to 0x0C00 |
| RAM | Size | 256 B | 512 Byte | 512 Byte |
| | | 0x02FF to 0x0200 | 0x03FF to 0x0200 | 0x03FF to 0x0200 |
| Peripherals | 16-bit | 0x01FF to 0x0100 | 0x01FF to 0x0100 | 0x01FF to 0x0100 |
| | 8-bit | 0x00FF to 0x0010 | 0x00FF to 0x0010 | 0x00FF to 0x0010 |
| | 8-bit SFR | 0x000F to 0x0000 | 0x000F to 0x0000 | 0x000F to 0x0000 |

4.7 Bootstrap Loader (BSL)

The MSP430F2132 bootstrap loader (BSL) enables users to program the flash memory or RAM using a UART serial interface. Access to the MSP430F2132 memory via the BSL is protected by user-defined password. For complete description of the features of the BSL and its implementation, see the *MSP430 Programming Via the Bootstrap Loader User's Guide* ([SLAU319](#)).

Table 9. BSL Function Pins

| BSL FUNCTION | PW PACKAGE PINS | RHB, RTV PACKAGE PINS |
|---------------|-----------------|-----------------------|
| Data transmit | 22 - P1.1 | 22 - P1.1 |
| Data receive | 10 - P2.2 | 8 - P2.2 |

4.8 Flash Memory

The flash memory can be programmed via the JTAG port, the bootstrap loader, or in-system by the CPU. The CPU can perform single-byte and single-word writes to the flash memory. Features of the flash memory include:

- Flash memory has n segments of main memory and four segments of information memory (A to D) of 64 bytes each. Each segment in main memory is 512 bytes in size.
- Segments 0 to n may be erased in one step, or each segment may be individually erased.
- Segments A to D can be erased individually, or as a group with segments 0 to n. Segments A to D are also called *information memory*.
- Segment A contains calibration data. After reset, segment A is protected against programming and erasing. It can be unlocked, but care should be taken not to erase this segment if the device-specific calibration data is required.

4.9 Peripherals

Peripherals are connected to the CPU through data, address, and control buses and can be handled using all instructions. For complete module descriptions, see the *MSP430x2xx Family User's Guide (SLAU144)*.

4.10 Oscillator and System Clock

The clock system is supported by the basic clock module that includes support for a 32768-Hz watch crystal oscillator, an internal very-low-power low-frequency oscillator, an internal digitally-controlled oscillator (DCO), and a high-frequency crystal oscillator. The basic clock module is designed to meet the requirements of both low system cost and low power consumption. The internal DCO provides a fast turn-on clock source and stabilizes in less than 1 μ s. The basic clock module provides the following clock signals:

- Auxiliary clock (ACLK), sourced from a 32768-Hz watch crystal, a high-frequency crystal, or the internal very-low-power LF oscillator.
- Main clock (MCLK), the system clock used by the CPU.
- Sub-Main clock (SMCLK), the sub-system clock used by the peripheral modules.

The DCO settings to calibrate the DCO output frequency are stored in the information memory segment A.

4.11 Calibration Data Stored in Information Memory Segment A

Calibration data is stored for both the DCO and for ADC10 organized in a tag-length-value (TLV) structure.

Table 10. Tags Used By the ADC Calibration Tags

| NAME | ADDRESS | VALUE | DESCRIPTION |
|-------------|---------|-------|---|
| TAG_DCO_30 | 0x10F6 | 0x01 | DCO frequency calibration at $V_{CC} = 3$ V and $T_A = 30^\circ\text{C}$ at calibration |
| TAG_ADC10_1 | 0x10DA | 0x08 | ADC10_1 calibration tag |
| TAG_EMPTY | - | 0xFE | Identifier for empty memory areas |

Table 11. Labels Used By the ADC Calibration Tags

| LABEL | CONDITION AT CALIBRATION / DESCRIPTION | SIZE | ADDRESS OFFSET |
|-----------------------|---|------|----------------|
| CAL_ADC_25T85 | INCHx = 0x1010, REF2_5 = 1, $T_A = 85^\circ\text{C}$ | word | 0x0010 |
| CAL_ADC_25T30 | INCHx = 0x1010, REF2_5 = 1, $T_A = 30^\circ\text{C}$ | word | 0x000E |
| CAL_ADC_25VREF_FACTOR | REF2_5 = 1, $T_A = 30^\circ\text{C}$, $I_{VREF+} = 1$ mA | word | 0x000C |
| CAL_ADC_15T85 | INCHx = 0x1010, REF2_5 = 0, $T_A = 85^\circ\text{C}$ | word | 0x000A |
| CAL_ADC_15T30 | INCHx = 0x1010, REF2_5 = 0, $T_A = 30^\circ\text{C}$ | word | 0x0008 |
| CAL_ADC_15VREF_FACTOR | REF2_5 = 0, $T_A = 30^\circ\text{C}$, $I_{VREF+} = 0.5$ mA | word | 0x0006 |
| CAL_ADC_OFFSET | External $V_{REF} = 1.5$ V, $f_{ADC10CLK} = 5$ MHz | word | 0x0004 |
| CAL_ADC_GAIN_FACTOR | External $V_{REF} = 1.5$ V, $f_{ADC10CLK} = 5$ MHz | word | 0x0002 |
| CAL_BC1_1MHz | - | byte | 0x0009 |
| CAL_DCO_1MHz | - | byte | 0x0008 |
| CAL_BC1_8MHz | - | byte | 0x0007 |
| CAL_DCO_8MHz | - | byte | 0x0006 |
| CAL_BC1_12MHz | - | byte | 0x0005 |
| CAL_DCO_12MHz | - | byte | 0x0004 |
| CAL_BC1_16MHz | - | byte | 0x0003 |
| CAL_DCO_16MHz | - | byte | 0x0002 |

4.12 Brownout

The brownout circuit is implemented to provide the proper internal reset signal to the device during power on and power off.

4.13 Digital I/O

There are three 8-bit I/O ports implemented—ports P1, P2, and P3:

- All individual I/O bits are independently programmable.
- Any combination of input, output, and interrupt condition is possible.
- Edge-selectable interrupt input capability for all eight bits of port P1 and P2.
- Read/write access to port-control registers is supported by all instructions.
- Each I/O has an individually programmable pullup or pulldown resistor.

The MSP430F2132 provides up to 24 total port I/O pins available externally. See the device pinout for more information.

4.14 Watchdog Timer (WDT+)

The primary function of the WDT+ module is to perform a controlled system restart after a software problem occurs. If the selected time interval expires, a system reset is generated. If the watchdog function is not needed in an application, the module can be disabled or configured as an interval timer and can generate interrupts at selected time intervals.

4.15 ADC10

The ADC10 module supports fast 10-bit analog-to-digital conversions. The module implements a 10-bit SAR core, sample select control, reference generator and data transfer controller, or DTC, for automatic conversion result handling allowing ADC samples to be converted and stored without any CPU intervention.

4.16 Comparator_A+

The primary function of the Comparator_A+ module is to support precision slope analog-to-digital conversions, battery-voltage supervision, and monitoring of external analog signals.

4.17 Timer0_A3

Timer0_A3 is a 16-bit timer/counter with three capture/compare registers. Timer0_A3 can support multiple capture/compares, PWM outputs, and interval timing. Timer0_A3 also has extensive interrupt capabilities. Interrupts may be generated from the counter on overflow conditions and from each of the capture/compare registers.

Table 12. Timer0_A3 Signal Connections

| INPUT PIN NUMBER | | DEVICE INPUT SIGNAL | MODULE INPUT NAME | MODULE BLOCK | MODULE OUTPUT SIGNAL | OUTPUT PIN NUMBER | |
|------------------|-----------|---------------------|-------------------|--------------|----------------------|-------------------|------------------|
| PW | RHB, RTV | | | | | PW | RHB, RTV |
| 21 - P1.0 | 21 - P1.0 | TACLK | TACLK | Timer | NA | | |
| | | ACLK | ACLK | | | | |
| | | SMCLK | SMCLK | | | | |
| 9 - P2.1 | 7 - P2.1 | TAINCLK | INCLK | | | | |
| 22 - P1.1 | 22 - P1.1 | TA0 | CCI0A | CCR0 | TA0 | 22 - P1.1 | 22 - P1.1 |
| 10 - P2.2 | 8 - P2.2 | TA0 | CCI0B | | | 26 - P1.5 | 26 - P1.5 |
| | | DV _{SS} | GND | | | 10 - P2.2 | 8 - P2.2 |
| | | DV _{CC} | V _{CC} | | | ADC10 (internal) | ADC10 (internal) |
| 23 - P1.2 | 23 - P1.2 | TA1 | CCI1A | CCR1 | TA1 | 23 - P1.2 | 23 - P1.2 |
| | | CAOUT (internal) | CCI1B | | | 27 - P1.6 | 27 - P1.6 |
| | | DV _{SS} | GND | | | 19 - P2.3 | 18 - P2.3 |
| | | DV _{CC} | V _{CC} | | | ADC10 (internal) | ADC10 (internal) |
| 24 - P1.3 | 24 - P1.3 | TA2 | CCI2A | CCR2 | TA2 | 24 - P1.3 | 24 - P1.3 |
| | | ACLK (internal) | CCI2B | | | 28 - P1.7 | 28 - P1.7 |
| | | DV _{SS} | GND | | | 20 - P2.4 | 19 - P2.4 |
| | | DV _{CC} | V _{CC} | | | ADC10 (internal) | ADC10 (internal) |

4.18 Timer1_A2

Timer1_A2 is a 16-bit timer/counter with two capture/compare registers. Timer1_A2 can support multiple capture/compares, PWM outputs, and interval timing. Timer1_A2 also has extensive interrupt capabilities. Interrupts may be generated from the counter on overflow conditions and from each of the capture/compare registers.

Table 13. Timer1_A2 Signal Connections

| INPUT PIN NUMBER | | DEVICE INPUT SIGNAL | MODULE INPUT NAME | MODULE BLOCK | MODULE OUTPUT SIGNAL | OUTPUT PIN NUMBER | |
|------------------|-----------|---------------------|-------------------|--------------|----------------------|-------------------|-----------|
| PW | RHB, RTV | | | | | PW | RHB, RTV |
| 21 - P1.0 | 21 - P1.0 | TACLK | TACLK | Timer | NA | | |
| | | ACLK | ACLK | | | | |
| | | SMCLK | SMCLK | | | | |
| 9 - P2.1 | 7 - P2.1 | TAINCLK | INCLK | | | | |
| 22 - P1.1 | 22 - P1.1 | TA0 | CCI0A | CCR0 | TA0 | 17 - P3.6 | 15 - P3.6 |
| 17 - P3.6 | 15 - P3.6 | TA0 | CCI0B | | | | |
| | | DV _{SS} | GND | | | | |
| | | DV _{CC} | V _{CC} | | | | |
| 18 - P3.7 | 16 - P3.7 | TA1 | CCI1A | CCR1 | TA1 | 18 - P3.7 | 16 - P3.7 |
| | | CAOUT (internal) | CCI1B | | | | |
| | | DV _{SS} | GND | | | | |
| | | DV _{CC} | V _{CC} | | | | |

4.19 Universal Serial Communications Interface (USCI)

The USCI module is used for serial data communication. The USCI module supports synchronous communication protocols like SPI (3 or 4 pin), I2C and asynchronous communication protocols such as UART, enhanced UART with automatic baudrate detection (LIN), and IrDA.

USCI_A0 provides support for SPI (3 or 4 pin), UART, enhanced UART, and IrDA.

USCI_B0 provides support for SPI (3 or 4 pin) and I2C.

4.20 Peripheral File Map

Table 14. Peripherals With Word Access

| MODULE | REGISTER NAME | SHORT NAME | ADDRESS OFFSET |
|-----------------|--------------------------------------|------------|----------------|
| ADC10 | ADC data transfer start address | ADC10SA | 0x01BC |
| | ADC memory | ADC10MEM | 0x01B4 |
| | ADC control register 1 | ADC10CTL1 | 0x01B2 |
| | ADC control register 0 | ADC10CTL0 | 0x01B0 |
| | ADC analog enable 0 | ADC10AE0 | 0x004A |
| | ADC analog enable 1 | ADC10AE1 | 0x004B |
| | ADC data transfer control register 1 | ADC10DTC1 | 0x0049 |
| | ADC data transfer control register 0 | ADC10DTC0 | 0x0048 |
| Timer0_A3 | Capture/compare register | TA0CCR2 | 0x0176 |
| | Capture/compare register | TA0CCR1 | 0x0174 |
| | Capture/compare register | TA0CCR0 | 0x0172 |
| | Timer0_A3 register | TA0R | 0x0170 |
| | Capture/compare control | TA0CCTL2 | 0x0166 |
| | Capture/compare control | TA0CCTL1 | 0x0164 |
| | Capture/compare control | TA0CCTL0 | 0x0162 |
| | Timer0_A3 control | TA0CTL | 0x0160 |
| | Timer0_A3 interrupt vector | TA0IV | 0x012E |
| Timer1_A2 | Capture/compare register | TA1CCR1 | 0x0194 |
| | Capture/compare register | TA1CCR0 | 0x0192 |
| | Timer1_A2 register | TA1R | 0x0190 |
| | Capture/compare control | TA1CCTL1 | 0x0184 |
| | Capture/compare control | TA1CCTL0 | 0x0182 |
| | Timer1_A2 control | TA1CTL | 0x0180 |
| | Timer1_A2 interrupt vector | TA1IV | 0x011E |
| Flash Memory | Flash control 3 | FCTL3 | 0x012C |
| | Flash control 2 | FCTL2 | 0x012A |
| | Flash control 1 | FCTL1 | 0x0128 |
| Watchdog Timer+ | Watchdog/timer control | WDTCTL | 0x0120 |

Table 15. Peripherals With Byte Access

| MODULE | REGISTER NAME | SHORT NAME | ADDRESS OFFSET |
|---------|------------------------------|------------|----------------|
| USCI_B0 | USCI_B0 transmit buffer | UCB0TXBUF | 0x06F |
| | USCI_B0 receive buffer | UCB0RXBUF | 0x06E |
| | USCI_B0 status | UCB0STAT | 0x06D |
| | USCI_B0 I2C Interrupt enable | UCB0CIE | 0x06C |
| | USCI_B0 bit rate control 1 | UCB0BR1 | 0x06B |
| | USCI_B0 bit rate control 0 | UCB0BR0 | 0x06A |
| | USCI_B0 control 1 | UCB0CTL1 | 0x069 |
| | USCI_B0 control 0 | UCB0CTL0 | 0x068 |
| | USCI_B0 I2C slave address | UCB0SA | 0x011A |
| | USCI_B0 I2C own address | UCB0OA | 0x0118 |

Table 15. Peripherals With Byte Access (continued)

| MODULE | REGISTER NAME | SHORT NAME | ADDRESS OFFSET |
|----------------------------|--------------------------------|------------|----------------|
| USCI_A0 | USCI_A0 transmit buffer | UCA0TXBUF | 0x0067 |
| | USCI_A0 receive buffer | UCA0RXBUF | 0x0066 |
| | USCI_A0 status | UCA0STAT | 0x0065 |
| | USCI_A0 modulation control | UCA0MCTL | 0x0064 |
| | USCI_A0 baud rate control 1 | UCA0BR1 | 0x0063 |
| | USCI_A0 baud rate control 0 | UCA0BR0 | 0x0062 |
| | USCI_A0 control 1 | UCA0CTL1 | 0x0061 |
| | USCI_A0 control 0 | UCA0CTL0 | 0x0060 |
| | USCI_A0 IrDA receive control | UCA0IRRCTL | 0x005F |
| | USCI_A0 IrDA transmit control | UCA0IRTCTL | 0x005E |
| | USCI_A0 auto baud rate control | UCA0ABCTL | 0x005D |
| Comparator_A+ | Comparator_A port disable | CAPD | 0x005B |
| | Comparator_A control 2 | CACTL2 | 0x005A |
| | Comparator_A control 1 | CACTL1 | 0x0059 |
| Basic Clock System+ | Basic clock system control 3 | BCSCTL3 | 0x0053 |
| | Basic clock system control 2 | BCSCTL2 | 0x0058 |
| | Basic clock system control 1 | BCSCTL1 | 0x0057 |
| | DCO clock frequency control | DCOCTL | 0x0056 |
| Port P3 | Port P3 resistor enable | P3REN | 0x0010 |
| | Port P3 selection | P3SEL | 0x001B |
| | Port P3 direction | P3DIR | 0x001A |
| | Port P3 output | P3OUT | 0x0019 |
| | Port P3 input | P3IN | 0x0018 |
| Port P2 | Port P2 selection 2 | P2SEL2 | 0x0042 |
| | Port P2 resistor enable | P2REN | 0x002F |
| | Port P2 selection | P2SEL | 0x002E |
| | Port P2 interrupt enable | P2IE | 0x002D |
| | Port P2 interrupt edge select | P2IES | 0x002C |
| | Port P2 interrupt flag | P2IFG | 0x002B |
| | Port P2 direction | P2DIR | 0x002A |
| | Port P2 output | P2OUT | 0x0029 |
| Port P2 input | P2IN | 0x0028 | |
| Port P1 | Port P1 selection 2 register | P1SEL2 | 0x0041 |
| | Port P1 resistor enable | P1REN | 0x0027 |
| | Port P1 selection | P1SEL | 0x0026 |
| | Port P1 interrupt enable | P1IE | 0x0025 |
| | Port P1 interrupt edge select | P1IES | 0x0024 |
| | Port P1 interrupt flag | P1IFG | 0x0023 |
| | Port P1 direction | P1DIR | 0x0022 |
| | Port P1 output | P1OUT | 0x0021 |
| | Port P1 input | P1IN | 0x0020 |
| Special Function | SFR interrupt flag 2 | IFG2 | 0x0003 |
| | SFR interrupt flag 1 | IFG1 | 0x0002 |
| | SFR interrupt enable 2 | IE2 | 0x0001 |
| | SFR interrupt enable 1 | IE1 | 0x0000 |

5 Specifications

5.1 Absolute Maximum Ratings⁽¹⁾

| | | |
|---|---------------------|----------------------------|
| Voltage applied at V_{CC} to V_{SS} | | -0.3 V to 4.1 V |
| Voltage applied to any pin ⁽²⁾ | | -0.3 V to $V_{CC} + 0.3$ V |
| Diode current at any device terminal | | ± 2 mA |
| Storage temperature, T_{stg} ⁽³⁾ | Unprogrammed device | -55°C to 150°C |
| | Programmed device | -55°C to 150°C |

- (1) Stresses beyond those listed under *absolute maximum ratings* may cause permanent damage to the device. These are stress ratings only, and functional operation of the device at these or any other conditions beyond those indicated under *recommended operating conditions* is not implied. Exposure to absolute-maximum-rated conditions for extended periods may affect device reliability.
- (2) All voltages referenced to V_{SS} . The JTAG fuse-blow voltage, V_{FB} , is allowed to exceed the absolute maximum rating. The voltage is applied to the TEST pin when blowing the JTAG fuse.
- (3) Higher temperature may be applied during board soldering process according to the current JEDEC J-STD-020 specification with peak reflow temperatures not higher than classified on the device label on the shipping boxes or reels.

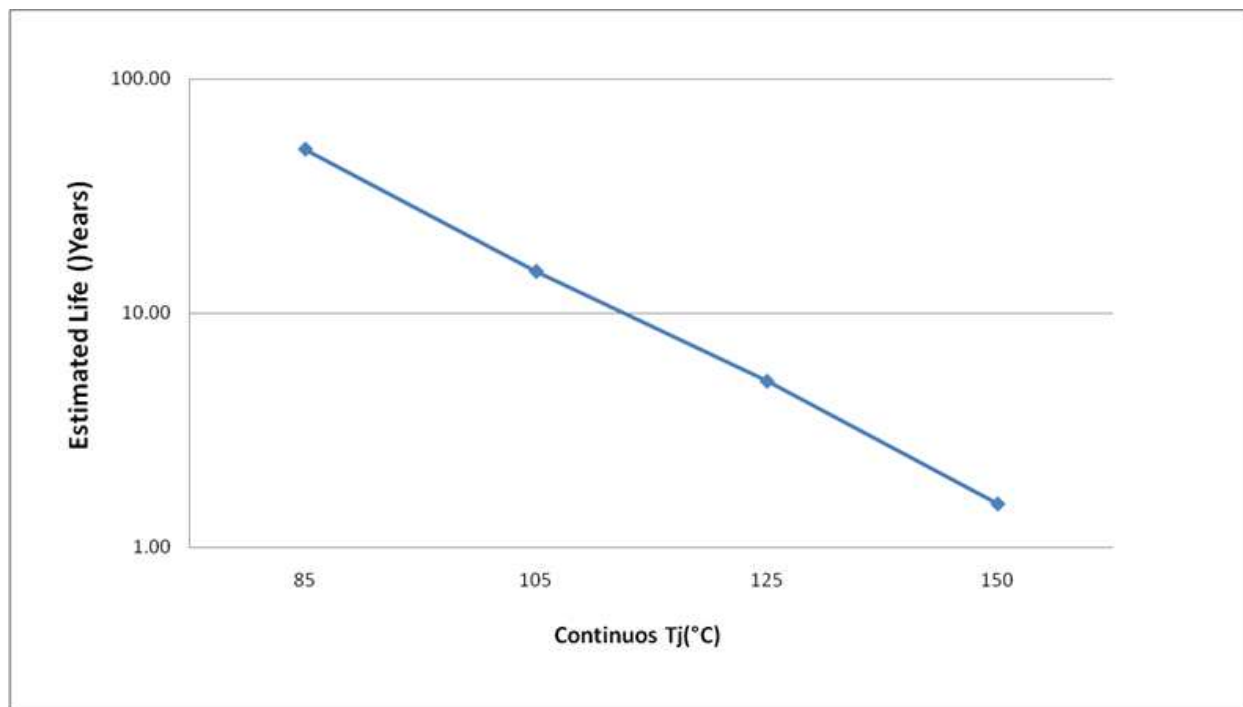

- A. See data sheet for absolute maximum and minimum recommended operating conditions.
- B. Silicon operating life design goal is 10 years at 110°C junction temperature (does not include package interconnect life).
- C. The predicted operating lifetime vs. junction temperature is based on reliability modeling using electromigration as the dominant failure mechanism affecting device wearout for the specific device process and design characteristics.

Figure 1. Operating Life Derating Chart

5.2 THERMAL INFORMATION

| THERMAL METRIC ⁽¹⁾ | | MSP430F2132-EP | | UNITS |
|-------------------------------|---|----------------|--|-------|
| | | RHB | | |
| | | 32 PINS | | |
| θ_{JA} | Junction-to-ambient thermal resistance ⁽²⁾ | 33.2 | | °C/W |
| $\theta_{Jc\text{top}}$ | Junction-to-case (top) thermal resistance ⁽³⁾ | 24.3 | | |
| θ_{JB} | Junction-to-board thermal resistance ⁽⁴⁾ | 7.3 | | |
| ψ_{JT} | Junction-to-top characterization parameter ⁽⁵⁾ | 0.3 | | |
| ψ_{JB} | Junction-to-board characterization parameter ⁽⁶⁾ | 7.3 | | |
| $\theta_{Jc\text{bot}}$ | Junction-to-case (bottom) thermal resistance ⁽⁷⁾ | 2.3 | | |

- (1) For more information about traditional and new thermal metrics, see the *Semiconductor and IC Package Thermal Metrics* application report (SPRA953).
- (2) The junction-to-ambient thermal resistance under natural convection is obtained in a simulation on a JEDEC-standard, high-K board, as specified in JESD51-7, in an environment described in JESD51-2a.
- (3) The junction-to-case (top) thermal resistance is obtained by simulating a cold plate test on the package top. No specific JEDEC-standard test exists, but a close description can be found in the ANSI SEMI standard G30-88.
- (4) The junction-to-board thermal resistance is obtained by simulating in an environment with a ring cold plate fixture to control the PCB temperature, as described in JESD51-8.
- (5) The junction-to-top characterization parameter, ψ_{JT} , estimates the junction temperature of a device in a real system and is extracted from the simulation data for obtaining $R_{\theta JA}$, using a procedure described in JESD51-2a (sections 6 and 7).
- (6) The junction-to-board characterization parameter, ψ_{JB} , estimates the junction temperature of a device in a real system and is extracted from the simulation data for obtaining $R_{\theta JA}$, using a procedure described in JESD51-2a (sections 6 and 7).
- (7) The junction-to-case (bottom) thermal resistance is obtained by simulating a cold plate test on the exposed (power) pad. No specific JEDEC standard test exists, but a close description can be found in the ANSI SEMI standard G30-88.

5.3 Recommended Operating Conditions⁽¹⁾

| | | | MIN | NOM | MAX | UNIT |
|---------------------|--|---|-----|-----|-----|------|
| V_{CC} | Supply voltage, $AV_{CC} = DV_{CC} = V_{CC}$ | During program execution | 1.8 | | 3.6 | V |
| | | During flash memory programming | 2.2 | | 3.6 | |
| V_{SS} | Supply voltage | $AV_{SS} = DV_{SS} = V_{SS}$ | 0 | | 0 | V |
| T_A | Operating free-air temperature | I version | -40 | | 85 | °C |
| | | Q version | -40 | | 125 | |
| f_{SYSTEM} | Processor frequency (maximum MCLK frequency) ⁽²⁾⁽¹⁾ (see Figure 2) | $V_{CC} = 1.8\text{ V}$, Duty cycle = 50% \pm 10% | dc | | 6 | MHz |
| | | $V_{CC} = 2.7\text{ V}$, Duty cycle = 50% \pm 10% | dc | | 12 | |
| | | $V_{CC} \geq 3.3\text{ V}$, Duty cycle = 50% \pm 10% | dc | | 16 | |

- (1) Modules might have a different maximum input clock specification. See the specification of the respective module in this data sheet.
- (2) The MSP430F2132 CPU is clocked directly with MCLK. Both the high and low phase of MCLK must not exceed the pulse duration of the specified maximum frequency.

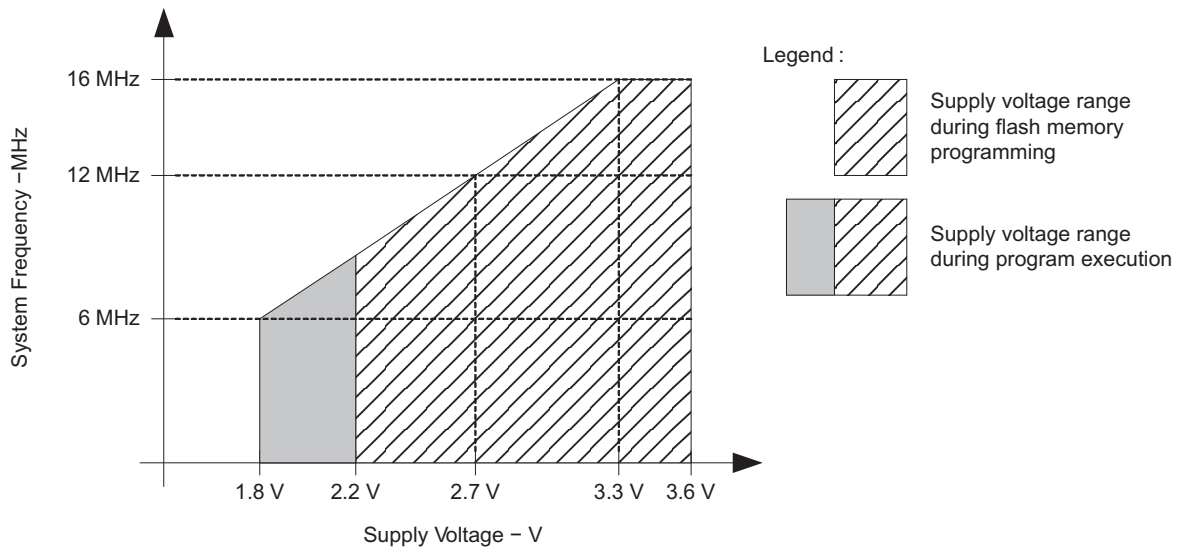

NOTE: Minimum processor frequency is defined by system clock. Flash program or erase operations require a minimum V_{CC} of 2.2 V.

Figure 2. Operating Area

5.4 Active Mode Supply Current (Into $DV_{CC} + AV_{CC}$) Excluding External Current

over recommended ranges of supply voltage and operating free-air temperature (unless otherwise noted)⁽¹⁾⁽²⁾. See [Typical Characteristics - Active-Mode Supply Current \(Into \$DV_{CC} + AV_{CC}\$ \)](#) for related characterization graphs.

| PARAMETER | TEST CONDITIONS | T_A | V_{CC} | MIN | TYP | MAX | UNIT |
|--|---|---------------|----------|-----|-----|-----|---------|
| $I_{AM,1MHz}$ Active mode (AM) current (1 MHz) | $f_{DCO} = f_{MCLK} = f_{SMCLK} = 1$ MHz, $f_{ACLK} = 32768$ Hz, Program executes in flash, BCSCTL1 = CALBC1_1MHZ, DCOCTL = CALDCO_1MHZ, CPUOFF = 0, SCG0 = 0, SCG1 = 0, OSCOFF = 0 | | 2.2 V | | 250 | 345 | μA |
| | | | 3 V | | 350 | 455 | |
| $I_{AM,1MHz}$ Active mode (AM) current (1 MHz) | $f_{DCO} = f_{MCLK} = f_{SMCLK} = 1$ MHz, $f_{ACLK} = 32768$ Hz, Program executes in RAM, BCSCTL1 = CALBC1_1MHZ, DCOCTL = CALDCO_1MHZ, CPUOFF = 0, SCG0 = 0, SCG1 = 0, OSCOFF = 0 | | 2.2 V | | 220 | | μA |
| | | | 3 V | | 300 | | |
| $I_{AM,4kHz}$ Active mode (AM) current (4 kHz) | $f_{MCLK} = f_{SMCLK} = f_{ACLK} = 32768$ Hz / 8 = 4096 Hz, $f_{DCO} = 0$ Hz, Program executes in flash, SELMx = 11, SELS = 1, DIVMx = DIVSx = DIVAx = 11, CPUOFF = 0, SCG0 = 1, SCG1 = 0, OSCOFF = 0 | -40°C to 85°C | 2.2 V | | 2 | 5 | μA |
| | | 125°C | | | | 7 | |
| | | -40°C to 85°C | 3 V | | 3 | 7 | |
| | | 125°C | | | | 10 | |
| $I_{AM,100kHz}$ Active mode (AM) current (100 kHz) | $f_{MCLK} = f_{SMCLK} = f_{DCO(0,0)} \approx 100$ kHz, $f_{ACLK} = 0$ Hz, Program executes in flash, RSELx = 0, DCOx = 0, CPUOFF = 0, SCG0 = 0, SCG1 = 0, OSCOFF = 1 | -40°C to 85°C | 2.2 V | | 60 | 85 | μA |
| | | 125°C | | | | 95 | |
| | | -40°C to 85°C | 3 V | | 72 | 95 | |
| | | 125°C | | | | 105 | |

(1) All inputs are tied to 0 V or V_{CC} . Outputs do not source or sink any current.

(2) The currents are characterized with a Micro Crystal CC4V-T1A SMD crystal with a load capacitance of 9 pF. The internal and external load capacitance is chosen to closely match the required 9 pF.

5.5 Low-Power-Mode Supply Currents (Into V_{CC}) Excluding External Current⁽¹⁾⁽²⁾

over recommended ranges of supply voltage and operating free-air temperature (unless otherwise noted). See [Typical Characteristics - LPM4 Current](#) for related characterization graphs.

| PARAMETER | TEST CONDITIONS | T_A | V_{CC} | MIN | TYP | MAX | UNIT | |
|---|---|---------------|------------|-----|-----|-----|---------|-----|
| $I_{LPM0, 1MHz}$ Low-power mode 0 (LPM0) current ⁽³⁾ | $f_{MCLK} = 0$ MHz, $f_{SMCLK} = f_{DCO} = 1$ MHz, $f_{ACLK} = 32768$ Hz, BCSCTL1 = CALBC1_1MHZ, DCOCTL = CALDCO_1MHZ, CPUOFF = 1, SCG0 = 0, SCG1 = 0, OSCOFF = 0 | -40°C to 85°C | 2.2 V | | 55 | 66 | μ A | |
| | | 105°C | | | | 68 | | |
| | | -40°C to 85°C | 3 V | | 70 | 83 | | |
| | | 105°C | | | | 90 | | |
| $I_{LPM0, 100kHz}$ Low-power mode 0 (LPM0) current ⁽³⁾ | $f_{MCLK} = 0$ MHz, $f_{SMCLK} = f_{DCO}(0, 0) \approx 100$ kHz, $f_{ACLK} = 0$ Hz, RSELX = 0, DCOX = 0, CPUOFF = 1, SCG0 = 0, SCG1 = 0, OSCOFF = 1 | -40°C to 85°C | 2.2 V | | 33 | 42 | μ A | |
| | | 125°C | | | | 46 | | |
| | | -40°C to 85°C | 3 V | | 37 | 46 | | |
| | | 125°C | | | | 50 | | |
| I_{LPM2} Low-power mode 2 (LPM2) current ⁽⁴⁾ | $f_{MCLK} = f_{SMCLK} = 0$ MHz, $f_{DCO} = 1$ MHz, $f_{ACLK} = 32768$ Hz, BCSCTL1 = CALBC1_1MHZ, DCOCTL = CALDCO_1MHZ, CPUOFF = 1, SCG0 = 0, SCG1 = 1, OSCOFF = 0 | -40°C to 85°C | 2.2 V | | 20 | 25 | μ A | |
| | | 125°C | | | | 29 | | |
| | | -40°C to 85°C | 3 V | | 22 | 27 | | |
| | | 125°C | | | | 33 | | |
| $I_{LPM3, LFX1}$ Low-power mode 3 (LPM3) current ⁽⁴⁾ | $f_{DCO} = f_{MCLK} = f_{SMCLK} = 0$ MHz, $f_{ACLK} = 32768$ Hz, CPUOFF = 1, SCG0 = 1, SCG1 = 1, OSCOFF = 0 | -40°C to 25°C | 2.2 V | | 0.7 | 1.2 | μ A | |
| | | 85°C | | | | 1.6 | | 2.3 |
| | | 105°C | | | | 3 | | 6 |
| | | -40°C to 25°C | 3 V | | 0.9 | 1.9 | | |
| | | 85°C | | | | 1.6 | | 2.8 |
| | | 105°C | | | | 3 | | 7 |
| $I_{LPM3, VLO}$ Low-power mode 3 current, (LPM3) ⁽⁴⁾ | $f_{DCO} = f_{MCLK} = f_{SMCLK} = 0$ MHz, f_{ACLK} from internal LF oscillator (VLO), CPUOFF = 1, SCG0 = 1, SCG1 = 1, OSCOFF = 0 | -40°C to 25°C | 2.2 V | | 0.3 | 0.7 | μ A | |
| | | 85°C | | | | 1.2 | | 1.9 |
| | | 125°C | | | | 2 | | 6 |
| | | -40°C to 25°C | 3 V | | 0.7 | 0.8 | | |
| | | 85°C | | | | 1.4 | | 2.1 |
| | | 125°C | | | | 2.5 | | 6.5 |
| I_{LPM4} Low-power mode 4 (LPM4) current ⁽⁵⁾ | $f_{DCO} = f_{MCLK} = f_{SMCLK} = 0$ MHz, $f_{ACLK} = 0$ Hz, CPUOFF = 1, SCG0 = 1, SCG1 = 1, OSCOFF = 1 | -40°C | 2.2 V, 3 V | | 0.1 | 0.5 | μ A | |
| | | 25°C | | | | 0.1 | | 0.5 |
| | | 85°C | | | | 0.8 | | 1.5 |
| | | 125°C | | | | 2 | | 4.5 |

(1) All inputs are tied to 0 V or V_{CC} . Outputs do not source or sink any current.

(2) The currents are characterized with a Micro Crystal CC4V-T1A SMD crystal with a load capacitance of 9 pF. The internal and external load capacitance is chosen to closely match the required 9 pF.

(3) Current for brownout and WDT clocked by SMCLK included.

(4) Current for brownout and WDT clocked by ACLK included.

(5) Current for brownout included.

5.6 Schmitt-Trigger Inputs (Ports P1, P2, P3, JTAG, $\overline{\text{RST/NMI}}$, XIN⁽¹⁾)

over recommended ranges of supply voltage and operating free-air temperature (unless otherwise noted)

| PARAMETER | | TEST CONDITIONS | V _{CC} | MIN | TYP | MAX | UNIT |
|-------------------|---|--|-----------------|----------------------|------|----------------------|------|
| V _{IT+} | Positive-going input threshold voltage | | | 0.45 V _{CC} | | 0.75 V _{CC} | V |
| | | | 2.2 V | 0.95 | 1.70 | | |
| | | | 3 V | 1.30 | 2.30 | | |
| V _{IT-} | Negative-going input threshold voltage | | | 0.25 V _{CC} | | 0.55 V _{CC} | V |
| | | | 2.2 V | 0.50 | 1.25 | | |
| | | | 3 V | 0.70 | 1.70 | | |
| V _{hys} | Input voltage hysteresis (V _{IT+} - V _{IT-}) | | 2.2 V | 0.15 | | 1.05 | V |
| | | | 3 V | 0.25 | | 1.05 | |
| R _{Pull} | Pullup/pulldown resistor | For pullup: V _{IN} = V _{SS} , For pulldown: V _{IN} = V _{CC} | | 19 | 35 | 52 | kΩ |
| C _I | Input capacitance | V _{IN} = V _{SS} or V _{CC} | | | 5 | | pF |

(1) XIN only in bypass mode

5.7 Inputs (Ports P1, P2)

over recommended ranges of supply voltage and operating free-air temperature (unless otherwise noted)

| PARAMETER | | TEST CONDITIONS | V _{CC} | MIN | TYP | MAX | UNIT |
|--------------------|---------------------------|---|-----------------|-----|-----|-----|------|
| t _(int) | External interrupt timing | Port P1, P2: P1.x to P2.x, External trigger pulse duration to set interrupt flag ⁽¹⁾ | 2.2 V, 3 V | 20 | | | ns |

(1) An external signal sets the interrupt flag every time the minimum interrupt pulse duration t_(int) is met. It may be set with trigger signals shorter than t_(int).

5.8 Leakage Current (Ports P1, P2, P3)

over recommended ranges of supply voltage and operating free-air temperature (unless otherwise noted)

| PARAMETER | | TEST CONDITIONS | V _{CC} | MIN | TYP | MAX | UNIT |
|------------------------|--------------------------------|-----------------|-----------------|-----|-----|-----|------|
| I _{Ikg(Px.y)} | High-impedance leakage current | (1) (2) | 2.2 V, 3 V | | | ±51 | nA |

(1) The leakage current is measured with V_{SS} or V_{CC} applied to the corresponding pin(s), unless otherwise noted.

(2) The leakage of the digital port pins is measured individually. The port pin is selected for input and the pullup or pulldown resistor is disabled.

5.9 Outputs (Ports P1, P2, P3)

over recommended ranges of supply voltage and operating free-air temperature (unless otherwise noted)

| PARAMETER | | TEST CONDITIONS | V _{CC} | MIN | MAX | UNIT |
|-----------------|---------------------------|---|-----------------|------------------------|------------------------|------|
| V _{OH} | High-level output voltage | I _{OH(max)} = -1.5 mA ⁽¹⁾ | 2.2 V | V _{CC} - 0.3 | V _{CC} | V |
| | | I _{OH(max)} = -6 mA ⁽²⁾ | | V _{CC} - 0.65 | V _{CC} | |
| | | I _{OH(max)} = -1.5 mA ⁽¹⁾ | 3 V | V _{CC} - 0.3 | V _{CC} | |
| | | I _{OH(max)} = -6 mA ⁽²⁾ | | V _{CC} - 0.65 | V _{CC} | |
| V _{OL} | Low-level output voltage | I _{OL(max)} = 1.5 mA ⁽¹⁾ | 2.2 V | V _{SS} | V _{SS} + 0.3 | V |
| | | I _{OL(max)} = 6 mA ⁽²⁾ | | V _{SS} | V _{SS} + 0.65 | |
| | | I _{OL(max)} = 1.5 mA ⁽¹⁾ | 3 V | V _{SS} | V _{SS} + 0.3 | |
| | | I _{OL(max)} = 6 mA ⁽²⁾ | | V _{SS} | V _{SS} + 0.65 | |

- (1) The maximum total current, I_{OH(max)} and I_{OL(max)}, for all outputs combined, should not exceed ±12 mA to hold the maximum voltage drop specified.
- (2) The maximum total current, I_{OH(max)} and I_{OL(max)}, for all outputs combined, should not exceed ±48 mA to hold the maximum voltage drop specified.

5.10 Output Frequency (Ports P1, P2, P3)⁽¹⁾

over recommended ranges of supply voltage and operating free-air temperature (unless otherwise noted). See [Typical Characteristics - Outputs](#) for related characterization graphs.

| PARAMETER | | TEST CONDITIONS | V _{CC} | MIN | TYP | MAX | UNIT |
|-----------------------|-----------------------------------|---|-----------------|-----|-----|-----|------|
| f _{Px,y} | Port output frequency (with load) | P1.4/SMCLK, C _L = 20 pF, R _L = 1 kΩ ⁽²⁾⁽³⁾ | 2.2 V | | | 7.5 | MHz |
| | | | 3 V | | | 12 | |
| f _{Port*CLK} | Clock output frequency | P2.0/ACLK, P1.4/SMCLK, C _L = 20 pF ⁽³⁾ | 2.2 V | | | 7.5 | MHz |
| | | | 3 V | | | 16 | |

- (1) Not ensured for T_A > 105°C.
- (2) Alternatively, a resistive divider with two 0.5-kΩ resistors between V_{CC} and V_{SS} is used as load. The output is connected to the center tap of the divider.
- (3) The output voltage reaches at least 10% and 90% V_{CC} at the specified toggle frequency.

5.11 POR and Brownout Reset (BOR)⁽¹⁾⁽²⁾

over recommended ranges of supply voltage and operating free-air temperature (unless otherwise noted). See [Typical Characteristics - POR/Brownout Reset \(BOR\)](#) for related characterization graphs.

| PARAMETER | TEST CONDITIONS | V _{CC} | MIN | TYP | MAX | UNIT |
|-------------------------|--|-------------------------------|-----|----------------------------|------|------|
| V _{CC(start)} | See Figure 3 | dV _{CC} / dt ≤ 3 V/s | | 0.7 × V _(B_IT-) | | V |
| V _(B_IT-) | See Figure 3 through Figure 20 | dV _{CC} / dt ≤ 3 V/s | | | 1.75 | V |
| V _{hys(B_IT-)} | See Figure 3 | dV _{CC} / dt ≤ 3 V/s | 65 | 130 | 215 | mV |
| t _{d(BOR)} | See Figure 3 | | | | 2000 | μs |
| t _(reset) | Pulse duration needed at $\overline{\text{RST}}/\text{NMI}$ pin to accepted reset internally | 2.2 V, 3 V | 2 | | | μs |

- (1) The current consumption of the brownout module is already included in the I_{CC} current consumption data. The voltage level V_(B_IT-) + V_{hys(B_IT-)} is ≤ 1.8 V.
- (2) During power up, the CPU begins code execution following a period of t_{d(BOR)} after V_{CC} = V_(B_IT-) + V_{hys(B_IT-)}. The default DCO settings must not be changed until V_{CC} ≥ V_{CC(min)}, where V_{CC(min)} is the minimum supply voltage for the desired operating frequency.

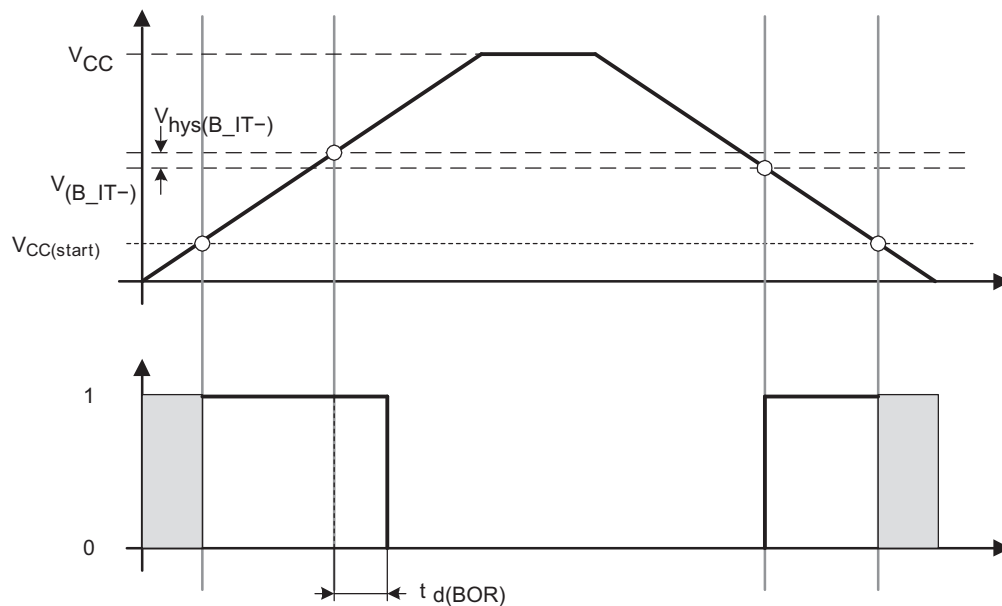

Figure 3. POR and BOR vs Supply Voltage

5.12 Main DCO Characteristics

- All ranges selected by RSELx overlap with RSELx + 1: RSELx = 0 overlaps RSELx = 1, ... RSELx = 14 overlaps RSELx = 15.
- DCO control bits DCOx have a step size as defined by parameter S_{DCO}.
- Modulation control bits MODx select how often f_{DCO(RSEL,DCO+1)} is used within the period of 32 DCOCLK cycles. The frequency f_{DCO(RSEL,DCO)} is used for the remaining cycles. The frequency is an average equal to:

$$f_{\text{average}} = \frac{32 \times f_{\text{DCO(RSEL,DCO)}} \times f_{\text{DCO(RSEL,DCO+1)}}}{\text{MOD} \times f_{\text{DCO(RSEL,DCO)}} + (32 - \text{MOD}) \times f_{\text{DCO(RSEL,DCO+1)}}$$

5.13 DCO Frequency

over recommended ranges of supply voltage and operating free-air temperature (unless otherwise noted). See [Typical Characteristics - Calibrated 1-MHz DCO Frequency](#) for related characterization graphs.

DCO Frequency (continued)

over recommended ranges of supply voltage and operating free-air temperature (unless otherwise noted). See [Typical Characteristics - Calibrated 1-MHz DCO Frequency](#) for related characterization graphs.

| PARAMETER | | TEST CONDITIONS | V _{CC} | MIN | TYP | MAX | UNIT |
|------------------------|--|--|-----------------|-------|------|-------|-------|
| V _{CC} | Supply voltage range | RSELx < 14 | | 1.8 | | 3.6 | V |
| | | RSELx = 14 | | 2.2 | | 3.6 | |
| | | RSELx = 15 | | 3.0 | | 3.6 | |
| f _{DCO(0,0)} | DCO frequency (0, 0) | RSELx = 0, DCOx = 0, MODx = 0 | 2.2 V, 3 V | 0.055 | | 0.145 | MHz |
| f _{DCO(0,3)} | DCO frequency (0, 3) | RSELx = 0, DCOx = 3, MODx = 0 | 2.2 V, 3 V | 0.065 | | 0.175 | MHz |
| f _{DCO(1,3)} | DCO frequency (1, 3) | RSELx = 1, DCOx = 3, MODx = 0 | 2.2 V, 3 V | 0.095 | | 0.205 | MHz |
| f _{DCO(2,3)} | DCO frequency (2, 3) | RSELx = 2, DCOx = 3, MODx = 0 | 2.2 V, 3 V | 0.135 | | 0.285 | MHz |
| f _{DCO(3,3)} | DCO frequency (3, 3) | RSELx = 3, DCOx = 3, MODx = 0 | 2.2 V, 3 V | 0.195 | | 0.405 | MHz |
| f _{DCO(4,3)} | DCO frequency (4, 3) | RSELx = 4, DCOx = 3, MODx = 0 | 2.2 V, 3 V | 0.27 | | 0.55 | MHz |
| f _{DCO(5,3)} | DCO frequency (5, 3) | RSELx = 5, DCOx = 3, MODx = 0 | 2.2 V, 3 V | 0.38 | | 0.78 | MHz |
| f _{DCO(6,3)} | DCO frequency (6, 3) | RSELx = 6, DCOx = 3, MODx = 0 | 2.2 V, 3 V | 0.53 | | 1.07 | MHz |
| f _{DCO(7,3)} | DCO frequency (7, 3) | RSELx = 7, DCOx = 3, MODx = 0 | 2.2 V, 3 V | 0.70 | | 1.60 | MHz |
| f _{DCO(8,3)} | DCO frequency (8, 3) | RSELx = 8, DCOx = 3, MODx = 0 | 2.2 V, 3 V | 1.05 | | 2.20 | MHz |
| f _{DCO(9,3)} | DCO frequency (9, 3) | RSELx = 9, DCOx = 3, MODx = 0 | 2.2 V, 3 V | 1.50 | | 3.10 | MHz |
| f _{DCO(10,3)} | DCO frequency (10, 3) | RSELx = 10, DCOx = 3, MODx = 0 | 2.2 V, 3 V | 2.40 | | 4.40 | MHz |
| f _{DCO(11,3)} | DCO frequency (11, 3) | RSELx = 11, DCOx = 3, MODx = 0 | 2.2 V, 3 V | 2.90 | | 5.60 | MHz |
| f _{DCO(12,3)} | DCO frequency (12, 3) | RSELx = 12, DCOx = 3, MODx = 0 | 2.2 V, 3 V | 4.20 | | 7.40 | MHz |
| f _{DCO(13,3)} | DCO frequency (13, 3) | RSELx = 13, DCOx = 3, MODx = 0 | 2.2 V, 3 V | 5.90 | | 9.70 | MHz |
| f _{DCO(14,3)} | DCO frequency (14, 3) | RSELx = 14, DCOx = 3, MODx = 0 | 2.2 V, 3 V | 8.50 | | 14.0 | MHz |
| f _{DCO(15,3)} | DCO frequency (15, 3) | RSELx = 15, DCOx = 3, MODx = 0 | 3 V | 11.5 | | 19 | MHz |
| f _{DCO(15,7)} | DCO frequency (15, 7) | RSELx = 15, DCOx = 7, MODx = 0 | 3 V | 15.5 | | 26.5 | MHz |
| S _{RSEL} | Frequency step between range RSEL and RSEL+1 | $S_{RSEL} = f_{DCO(RSEL+1,DCO)} / f_{DCO(RSEL,DCO)}$ | 2.2 V, 3 V | | | 1.56 | ratio |
| S _{DCO} | Frequency step between tap DCO and DCO+1 | $S_{DCO} = f_{DCO(RSEL,DCO+1)} / f_{DCO(RSEL,DCO)}$ | 2.2 V, 3 V | 1.04 | 1.08 | 1.13 | ratio |
| | Duty cycle | Measured at P1.4/SMCLK | 2.2 V, 3 V | 35 | 50 | 65 | % |

5.14 Calibrated DCO Frequencies - Tolerance at Calibration

over recommended ranges of supply voltage and operating free-air temperature (unless otherwise noted)

| PARAMETER | TEST CONDITIONS | T _A | V _{CC} | MIN | TYP | MAX | UNIT |
|--|--|----------------|-----------------|-------|------|-------|------|
| Frequency tolerance at calibration | | 25°C | 3 V | -1 | ±0.2 | +1 | % |
| f _{CAL(1MHz)} 1-MHz calibration value | BCSCTL1 = CALBC1_1MHZ, DCOCTL = CALDCO_1MHZ, Gating time: 5 ms | 25°C | 3 V | 0.990 | 1 | 1.010 | MHz |
| f _{CAL(8MHz)} 8-MHz calibration value | BCSCTL1 = CALBC1_8MHZ, DCOCTL = CALDCO_8MHZ, Gating time: 5 ms | 25°C | 3 V | 7.920 | 8 | 8.080 | MHz |
| f _{CAL(12MHz)} 12-MHz calibration value | BCSCTL1 = CALBC1_12MHZ, DCOCTL = CALDCO_12MHZ, Gating time: 5 ms | 25°C | 3 V | 11.88 | 12 | 12.12 | MHz |
| f _{CAL(16MHz)} 16-MHz calibration value | BCSCTL1 = CALBC1_16MHZ, DCOCTL = CALDCO_16MHZ, Gating time: 2 ms | 25°C | 3 V | 15.84 | 16 | 16.16 | MHz |

5.15 Calibrated DCO Frequencies - Tolerance Over Temperature 0°C to 85°C

over recommended ranges of supply voltage and operating free-air temperature (unless otherwise noted)

| PARAMETER | TEST CONDITIONS | T _A | V _{CC} | MIN | TYP | MAX | UNIT |
|--|--|----------------|-----------------|-------|------|-------|------|
| 1-MHz tolerance over temperature | | 0°C to 85°C | 3 V | -2.5 | ±0.5 | +2.5 | % |
| 8-MHz tolerance over temperature | | 0°C to 85°C | 3 V | -2.5 | ±1 | +2.5 | % |
| 12-MHz tolerance over temperature | | 0°C to 85°C | 3 V | -2.5 | ±1 | +2.5 | % |
| 16-MHz tolerance over temperature | | 0°C to 85°C | 3 V | -3 | ±2 | +3 | % |
| f _{CAL(1MHz)} 1-MHz calibration value | BCSCTL1 = CALBC1_1MHZ, DCOCTL = CALDCO_1MHZ, Gating time: 5 ms | 0°C to 85°C | 2.2 V | 0.97 | 1 | 1.03 | MHz |
| | | | 3 V | 0.975 | 1 | 1.025 | |
| | | | 3.6 V | 0.97 | 1 | 1.03 | |
| f _{CAL(8MHz)} 8-MHz calibration value | BCSCTL1 = CALBC1_8MHZ, DCOCTL = CALDCO_8MHZ, Gating time: 5 ms | 0°C to 85°C | 2.2 V | 7.76 | 8 | 8.4 | MHz |
| | | | 3 V | 7.8 | 8 | 8.2 | |
| | | | 3.6 V | 7.6 | 8 | 8.24 | |
| f _{CAL(12MHz)} 12-MHz calibration value | BCSCTL1 = CALBC1_12MHZ, DCOCTL = CALDCO_12MHZ, Gating time: 5 ms | 0°C to 85°C | 2.2 V | 11.64 | 12 | 12.36 | MHz |
| | | | 3 V | 11.64 | 12 | 12.36 | |
| | | | 3.6 V | 11.64 | 12 | 12.36 | |
| f _{CAL(16MHz)} 16-MHz calibration value | BCSCTL1 = CALBC1_16MHZ, DCOCTL = CALDCO_16MHZ, Gating time: 2 ms | 0°C to 85°C | 3 V | 15.52 | 16 | 16.48 | MHz |
| | | | 3.6 V | 15 | 16 | 16.48 | |

5.16 Calibrated DCO Frequencies - Tolerance Over Supply Voltage V_{CC}

over recommended ranges of supply voltage and operating free-air temperature (unless otherwise noted)

| PARAMETER | TEST CONDITIONS | T_A | V_{CC} | MIN | TYP | MAX | UNIT |
|---|--|-------|----------------|-------|-----|-------|------|
| 1-MHz tolerance over V_{CC} | | 25°C | 1.8 V to 3.6 V | -3 | ±2 | +3 | % |
| 8-MHz tolerance over V_{CC} | | 25°C | 1.8 V to 3.6 V | -3 | ±2 | +3 | % |
| 12-MHz tolerance over V_{CC} | | 25°C | 2.2 V to 3.6 V | -3 | ±2 | +3 | % |
| 16-MHz tolerance over V_{CC} | | 25°C | 3 V to 3.6 V | -6 | ±2 | +3 | % |
| $f_{CAL(1MHz)}$ 1-MHz calibration value | BCSCTL1 = CALBC1_1MHZ, DCOCTL = CALDCO_1MHZ, Gating time: 5 ms | 25°C | 1.8 V to 3.6 V | 0.97 | 1 | 1.03 | MHz |
| $f_{CAL(8MHz)}$ 8-MHz calibration value | BCSCTL1 = CALBC1_8MHZ, DCOCTL = CALDCO_8MHZ, Gating time: 5 ms | 25°C | 1.8 V to 3.6 V | 7.76 | 8 | 8.24 | MHz |
| $f_{CAL(12MHz)}$ 12-MHz calibration value | BCSCTL1 = CALBC1_12MHZ, DCOCTL = CALDCO_12MHZ, Gating time: 5 ms | 25°C | 2.2 V to 3.6 V | 11.64 | 12 | 12.36 | MHz |
| $f_{CAL(16MHz)}$ 16-MHz calibration value | BCSCTL1 = CALBC1_16MHZ, DCOCTL = CALDCO_16MHZ, Gating time: 2 ms | 25°C | 3 V to 3.6 V | 15 | 16 | 16.48 | MHz |

5.17 Calibrated DCO Frequencies - Overall Tolerance

over recommended ranges of supply voltage and operating free-air temperature (unless otherwise noted)

| PARAMETER | TEST CONDITIONS | T_A | V_{CC} | MIN | TYP | MAX | UNIT |
|---|--|----------------|----------------|------|-----|------|------|
| 1-MHz tolerance overall | | -40°C to 125°C | 1.8 V to 3.6 V | -6 | ±2 | +6 | % |
| 8-MHz tolerance overall | | -40°C to 125°C | 1.8 V to 3.6 V | -6 | ±2 | +6 | % |
| 12-MHz tolerance overall | | -40°C to 125°C | 2.2 V to 3.6 V | -6 | ±2 | +6 | % |
| 16-MHz tolerance overall | | -40°C to 125°C | 3 V to 3.6 V | -7 | ±3 | +7 | % |
| $f_{CAL(1MHz)}$ 1-MHz calibration value | BCSCTL1 = CALBC1_1MHZ, DCOCTL = CALDCO_1MHZ, Gating time: 5 ms | -40°C to 125°C | 1.8 V to 3.6 V | 0.94 | 1 | 1.06 | MHz |
| $f_{CAL(8MHz)}$ 8-MHz calibration value | BCSCTL1 = CALBC1_8MHZ, DCOCTL = CALDCO_8MHZ, Gating time: 5 ms | -40°C to 125°C | 1.8 V to 3.6 V | 7.5 | 8 | 8.5 | MHz |
| $f_{CAL(12MHz)}$ 12-MHz calibration value | BCSCTL1 = CALBC1_12MHZ, DCOCTL = CALDCO_12MHZ, Gating time: 5 ms | -40°C to 125°C | 2.2 V to 3.6 V | 11.3 | 12 | 12.7 | MHz |
| $f_{CAL(16MHz)}$ 16-MHz calibration value | BCSCTL1 = CALBC1_16MHZ, DCOCTL = CALDCO_16MHZ, Gating time: 2 ms | -40°C to 125°C | 3 V to 3.6 V | 14.9 | 16 | 17.1 | MHz |

5.18 Wake-Up From Lower-Power Modes (LPM3/4)⁽¹⁾

over recommended ranges of supply voltage and operating free-air temperature (unless otherwise noted). See [Typical Characteristics - DCO Clock Wake-Up Time From LPM3/4](#) for related characterization graphs.

| PARAMETER | TEST CONDITIONS | V _{CC} | MIN | TYP | MAX | UNIT |
|--|--|-----------------|-----|--|-----|------|
| t _{DCO,LPM3/4} DCO clock wake-up time from LPM3/4 ⁽²⁾ | BCSCTL1 = CALBC1_1MHZ, DCOCTL = CALDCO_1MHZ | 2.2 V, 3 V | | | 2 | μs |
| | BCSCTL1 = CALBC1_8MHZ, DCOCTL = CALDCO_8MHZ | | | | 1.5 | |
| | BCSCTL1 = CALBC1_12MHZ, DCOCTL = CALDCO_12MHZ | | | | 1 | |
| | BCSCTL1 = CALBC1_16MHZ, DCOCTL = CALDCO_16MHZ | 3 V | | | 1 | |
| t _{CPU,LPM3/4} CPU wake-up time from LPM3/4 ⁽³⁾ | | | | 1 / f _{MCLK} + t _{Clock,LPM3/4} | | |

(1) Not ensured for T_A > 105°C.

(2) The DCO clock wake-up time is measured from the edge of an external wake-up signal (for example, a port interrupt) to the first clock edge observable externally on a clock pin (MCLK or SMCLK).

(3) Parameter applicable only if DCOCLK is used for MCLK.

5.19 DCO With External Resistor R_{OSC}⁽¹⁾

over recommended ranges of supply voltage and operating free-air temperature (unless otherwise noted). See [Typical Characteristics - DCO With External Resistor R_{OSC}](#) for related characterization graphs.

| PARAMETER | TEST CONDITIONS | V _{CC} | MIN | TYP | MAX | UNIT |
|---|--|-----------------|-----|------|-----|------|
| f _{DCO,ROSC} DCO output frequency with R _{OSC} | DCOR = 1, RSELx = 4, DCOx = 3, MODx = 0, T _A = 25°C | 2.2 V | | 1.8 | | MHz |
| | | 3 V | | 1.95 | | |
| D _T Temperature drift | DCOR = 1, RSELx = 4, DCOx = 3, MODx = 0 | 2.2 V, 3 V | | ±0.1 | | %/°C |
| D _V Drift with V _{CC} | DCOR = 1, RSELx = 4, DCOx = 3, MODx = 0 | 2.2 V, 3 V | | 10 | | %/V |

(1) R_{OSC} = 100 kΩ. Metal film resistor, type 0257, 0.6 W with 1% tolerance and T_K = ±50 ppm/°C.

5.20 Crystal Oscillator LFXT1, Low-Frequency Mode⁽¹⁾⁽²⁾

over recommended ranges of supply voltage and operating free-air temperature (unless otherwise noted). See [Typical Characteristics - LFXT1 Oscillator in HF Mode \(XTS = 1\)](#) for related characterization graphs.

| PARAMETER | | TEST CONDITIONS | V _{CC} | MIN | TYP | MAX | UNIT |
|-----------------------------|---|--|-----------------|-------|-------|-------|------|
| f _{LFXT1,LF} | LFXT1 oscillator crystal frequency, LF mode 0, 1 | XTS = 0, LFXT1Sx = 0 or 1 | 1.8 V to 3.6 V | | 32768 | | Hz |
| f _{LFXT1,LF,logic} | LFXT1 oscillator logic level square wave input frequency, LF mode | XTS = 0, XCAPx = 0, LFXT1Sx = 3 | 1.8 V to 3.6 V | 10000 | 32768 | 50000 | Hz |
| O _{A,LF} | Oscillation allowance for LF crystals | XTS = 0, LFXT1Sx = 0, f _{LFXT1,LF} = 32768 Hz, C _{L,eff} = 6 pF | | | 500 | | kΩ |
| | | XTS = 0, LFXT1Sx = 0, f _{LFXT1,LF} = 32768 Hz, C _{L,eff} = 12 pF | | | 200 | | |
| C _{L,eff} | Integrated effective load capacitance, LF mode ⁽³⁾ | XTS = 0, XCAPx = 0 | | | 1 | | pF |
| | | XTS = 0, XCAPx = 1 | | | 5.5 | | |
| | | XTS = 0, XCAPx = 2 | | | 8.5 | | |
| | | XTS = 0, XCAPx = 3 | | | 11 | | |
| | Duty cycle, LF mode | XTS = 0, Measured at ACLK, f _{LFXT1,LF} = 32768 Hz | 2.2 V, 3 V | 30 | 50 | 70 | % |
| f _{Fault,LF} | Oscillator fault frequency, LF mode ⁽⁴⁾ | XTS = 0, XCAPx = 0, LFXT1Sx = 3 ⁽⁵⁾ | 2.2 V, 3 V | 10 | | 10000 | Hz |

- (1) To improve EMI on the XT1 oscillator, the following guidelines should be observed.
 - (a) Keep the trace between the device and the crystal as short as possible.
 - (b) Design a good ground plane around the oscillator pins.
 - (c) Prevent crosstalk from other clock or data lines into oscillator pins XIN and XOUT.
 - (d) Avoid running PCB traces underneath or adjacent to the XIN and XOUT pins.
 - (e) Use assembly materials and praxis to avoid any parasitic load on the oscillator XIN and XOUT pins.
 - (f) If conformal coating is used, ensure that it does not induce capacitive/resistive leakage between the oscillator pins.
 - (g) Do not route the XOUT line to the JTAG header to support the serial programming adapter as shown in other documentation. This signal is no longer required for the serial programming adapter.
- (2) Use of the LFXT1 Crystal Oscillator at T_A > 105°C is not ensured. It is recommended that an external digital clock source or the internal DCO is used to provide clocking.
- (3) Includes parasitic bond and package capacitance (approximately 2 pF per pin). Because the PCB adds additional capacitance, it is recommended to verify the correct load by measuring the ACLK frequency. For a correct setup, the effective load capacitance should always match the specification of the crystal that is used.
- (4) Frequencies below the MIN specification set the fault flag. Frequencies above the MAX specification do not set the fault flag. Frequencies in between might set the flag.
- (5) Measured with logic-level input frequency but also applies to operation with crystals.

5.21 Internal Very-Low-Power Low-Frequency Oscillator (VLO)

over recommended ranges of supply voltage and operating free-air temperature (unless otherwise noted)

| PARAMETER | | T _A | V _{CC} | MIN | TYP | MAX | UNIT |
|-------------------------------------|---|----------------|-----------------|-----|-----|-----|------|
| f _{VLO} | VLO frequency | -40°C to 85°C | 2.2 V, 3 V | 4 | 12 | 20 | kHz |
| | | 125°C | | | | 23 | |
| df _{VLO} /dT | VLO frequency temperature drift ⁽¹⁾ | | 2.2 V, 3 V | | 0.5 | | %/°C |
| df _{VLO} /dV _{CC} | VLO frequency supply voltage drift ⁽²⁾ | | 1.8 V to 3.6 V | | 4 | | %/V |

- (1) Calculated using the box method:

$$[\text{MAX}(-40\dots 125^\circ\text{C}) - \text{MIN}(-40\dots 125^\circ\text{C})]/\text{MIN}(-40\dots 125^\circ\text{C})/[125^\circ\text{C} - (-40^\circ\text{C})]$$
- (2) Calculated using the box method: $[\text{MAX}(1.8\dots 3.6\text{ V}) - \text{MIN}(1.8\dots 3.6\text{ V})]/\text{MIN}(1.8\dots 3.6\text{ V})/(3.6\text{ V} - 1.8\text{ V})$

5.22 Crystal Oscillator LFXT1, High-Frequency Mode⁽¹⁾⁽²⁾

| PARAMETER | | TEST CONDITIONS | V _{CC} | MIN | TYP | MAX | UNIT |
|-----------------------------|--|---|-----------------|-----|------|-----|------|
| f _{LFXT1,HF0} | LFXT1 oscillator crystal frequency, HF mode 0 | XTS = 1, XCAPx = 0, LFXT1Sx = 0 | 1.8 V to 3.6 V | 0.4 | | 1 | MHz |
| f _{LFXT1,HF1} | LFXT1 oscillator crystal frequency, HF mode 1 | XTS = 1, XCAPx = 0, LFXT1Sx = 1 | 1.8 V to 3.6 V | 1 | | 4 | MHz |
| f _{LFXT1,HF2} | LFXT1 oscillator crystal frequency, HF mode 2 | XTS = 1, XCAPx = 0, LFXT1Sx = 2 | 1.8 V to 3.6 V | 2 | | 10 | MHz |
| | | | 2.2 V to 3.6 V | 2 | | 12 | |
| | | | 3 V to 3.6 V | 2 | | 16 | |
| f _{LFXT1,HF,logic} | LFXT1 oscillator logic-level square-wave input frequency, HF mode | XTS = 1, XCAPx = 0, LFXT1Sx = 3 | 1.8 V to 3.6 V | 0.4 | | 10 | MHz |
| | | | 2.2 V to 3.6 V | 0.4 | | 12 | |
| | | | 3 V to 3.6 V | 0.4 | | 16 | |
| O _{AHF} | Oscillation allowance for HF crystals (see Figure 27 and Figure 28) | XTS = 1, XCAPx = 0, LFXT1Sx = 0, f _{LFXT1,HF} = 1 MHz, C _{L,eff} = 15 pF | | | 2700 | | Ω |
| | | XTS = 1, XCAPx = 0, LFXT1Sx = 1, f _{LFXT1,HF} = 4 MHz, C _{L,eff} = 15 pF | | | 800 | | |
| | | XTS = 1, XCAPx = 0, LFXT1Sx = 2, f _{LFXT1,HF} = 16 MHz, C _{L,eff} = 15 pF | | | 300 | | |
| C _{L,eff} | Integrated effective load capacitance, HF mode ⁽³⁾ | XTS = 1, XCAPx = 0 ⁽⁴⁾ | | | 1 | | pF |
| | Duty cycle, HF mode | XTS = 1, XCAPx = 0, Measured at P2.0/ACLK, f _{LFXT1,HF} = 10 MHz | 2.2 V, 3 V | 40 | 50 | 60 | % |
| | | XTS = 1, XCAPx = 0, Measured at P2.0/ACLK, f _{LFXT1,HF} = 16 MHz | | 40 | 50 | 60 | |
| f _{Fault,HF} | Oscillator fault frequency ⁽⁵⁾ | XTS = 1, XCAPx = 0, LFXT1Sx = 3 ⁽⁶⁾ | 2.2 V, 3 V | 30 | | 300 | kHz |

- (1) To improve EMI on the XT2 oscillator the following guidelines should be observed:
 - (a) Keep the trace between the device and the crystal as short as possible.
 - (b) Design a good ground plane around the oscillator pins.
 - (c) Prevent crosstalk from other clock or data lines into oscillator pins XIN and XOUT.
 - (d) Avoid running PCB traces underneath or adjacent to the XIN and XOUT pins.
 - (e) Use assembly materials and praxis to avoid any parasitic load on the oscillator XIN and XOUT pins.
 - (f) If conformal coating is used, ensure that it does not induce capacitive or resistive leakage between the oscillator pins.
 - (g) Do not route the XOUT line to the JTAG header to support the serial programming adapter as shown in other documentation. This signal is no longer required for the serial programming adapter.
- (2) Use of the LFXT1 Crystal Oscillator at T_A > 105°C is not ensured. It is recommended that an external digital clock source or the internal DCO is used to provide clocking.
- (3) Includes parasitic bond and package capacitance (approximately 2 pF per pin). Because the PCB adds additional capacitance, it is recommended to verify the correct load by measuring the ACLK frequency. For a correct setup, the effective load capacitance should always match the specification of the used crystal.
- (4) Requires external capacitors at both terminals. Values are specified by crystal manufacturers.
- (5) Frequencies below the MIN specification set the fault flag, frequencies above the MAX specification do not set the fault flag, and frequencies in between might set the flag.
- (6) Measured with logic-level input frequency, but also applies to operation with crystals.

5.23 Timer0_A3

over recommended ranges of supply voltage and operating free-air temperature (unless otherwise noted)

| PARAMETER | | TEST CONDITIONS | V _{CC} | MIN | TYP | MAX | UNIT |
|---------------------|---------------------------|---|-----------------|-----|-----|-----|------|
| f _{TA} | Timer0_A3 clock frequency | Internal: SMCLK, ACLK External: TACLK, INCLK Duty cycle = 50% ± 10% | 2.2 V | | | 10 | MHz |
| | | | 3 V | | | 16 | |
| t _{TA,cap} | Timer0_A3 capture timing | TA0.0, TA0.1, TA0.2 | 2.2 V, 3 V | 20 | | | ns |

5.24 Timer1_A2

over recommended ranges of supply voltage and operating free-air temperature (unless otherwise noted)

| PARAMETER | | TEST CONDITIONS | V _{CC} | MIN | TYP | MAX | UNIT |
|---------------------|---------------------------|---|-----------------|-----|-----|-----|------|
| f _{TB} | Timer1_A2 clock frequency | Internal: SMCLK, ACLK External: TACLK, INCLK Duty cycle = 50% ± 10% | 2.2 V | | | 10 | MHz |
| | | | 3 V | | | 16 | |
| t _{TB,cap} | Timer1_A2 capture timing | TA1.0, TA1.1 | 2.2 V, 3 V | 20 | | | ns |

5.25 USCI (UART Mode)

over recommended ranges of supply voltage and operating free-air temperature (unless otherwise noted)

| PARAMETER | | CONDITIONS | V _{CC} | MIN | TYP | MAX | UNIT |
|-------------------------|---|---|-----------------|-----|-----|---------------------|------|
| f _{USCI} | USCI input clock frequency | Internal: SMCLK, ACLK External: UCLK Duty cycle = 50% ± 10% | | | | f _{SYSTEM} | MHz |
| f _{max,BITCLK} | Maximum BITCLK clock frequency (equals baud rate in Mbaud) ⁽¹⁾ | | 2.2 V, 3 V | 2 | | | MHz |
| t _τ | UART receive deglitch time ⁽²⁾ | | 2.2 V | 45 | 150 | | ns |
| | | | 3 V | 45 | 100 | | |

(1) The DCO wake-up time must be considered in LPM3 and LPM4 for baud rates above 1 MHz.

(2) Pulses on the UART receive input (UCxRX) shorter than the UART receive deglitch time are suppressed. To ensure that pulses are correctly recognized, their duration should exceed the maximum specification of the deglitch time.

5.26 USCI (SPI Master Mode)⁽¹⁾

over recommended ranges of supply voltage and operating free-air temperature (unless otherwise noted)

(see [Figure 4](#) and [Figure 5](#))

| PARAMETER | | TEST CONDITIONS | V _{CC} | MIN | TYP | MAX | UNIT |
|-----------------------|--|--|-----------------|-----|-----|---------------------|------|
| f _{USCI} | USCI input clock frequency | SMCLK, ACLK Duty cycle = 50% ± 10% | | | | f _{SYSTEM} | MHz |
| t _{SU,MI} | SOMI input data setup time | | 2.2 V | 110 | | | ns |
| | | | 3 V | 75 | | | |
| t _{HD,MI} | SOMI input data hold time | | 2.2 V | 0 | | | ns |
| | | | 3 V | 0 | | | |
| t _{VALID,MO} | SIMO output data valid time ⁽²⁾ | UCLK edge to SIMO valid, C _L = 20 pF | 2.2 V | | | 30 | ns |
| | | | 3 V | | | 20 | |

(1) f_{UCxCLK} = 1/2t_{LO/HI} with t_{LO/HI} ≥ max(t_{VALID,MO(USCI)} + t_{SU,SI(Slave)}, t_{SU,MI(USCI)} + t_{VALID,SO(Slave)}).

For the slave's parameters t_{SU,SI(Slave)} and t_{VALID,SO(Slave)}, see the SPI parameters of the attached slave.

(2) Not ensured for T_A > 105°C.

5.27 USCI (SPI Slave Mode)⁽¹⁾

over recommended ranges of supply voltage and operating free-air temperature (unless otherwise noted)

(see [Figure 6](#) and [Figure 7](#))

| PARAMETER | | TEST CONDITIONS | V _{CC} | MIN | TYP | MAX | UNIT |
|-----------------------|---|--|-----------------|-----|-----|-----|------|
| t _{STE,LEAD} | STE lead time, STE low to clock | | 2.2 V, 3 V | | 50 | | ns |
| t _{STE,LAG} | STE lag time, Last clock to STE high | | 2.2 V, 3 V | 10 | | | ns |
| t _{STE,ACC} | STE access time, STE low to SOMI data out | | 2.2 V, 3 V | | 50 | | ns |
| t _{STE,DIS} | STE disable time, STE high to SOMI high impedance | | 2.2 V, 3 V | | 50 | | ns |
| t _{SU,SI} | SIMO input data setup time | | 2.2 V | 20 | | | ns |
| | | | 3 V | 15 | | | |
| t _{HD,SI} | SIMO input data hold time | | 2.2 V | 10 | | | ns |
| | | | 3 V | 10 | | | |
| t _{VALID,SO} | SOMI output data valid time ⁽²⁾ | UCLK edge to SOMI valid, C _L = 20 pF | 2.2 V | | 75 | 110 | ns |
| | | | 3 V | | 50 | 75 | |

(1) f_{UCxCLK} = 1/2t_{LO/HI} with t_{LO/HI} ≥ max(t_{VALID,MO(Master)} + t_{SU,SI(USCI)}, t_{SU,MI(Master)} + t_{VALID,SO(USCI)}).

For the master's parameters t_{SU,MI(Master)} and t_{VALID,MO(Master)} refer to the SPI parameters of the attached slave.

(2) Not ensured for T_A > 105°C.

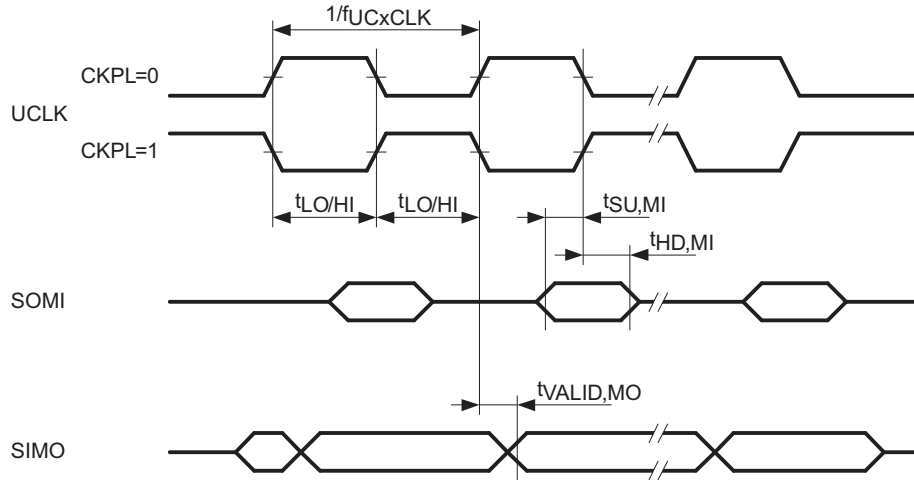

Figure 4. SPI Master Mode, CKPH = 0

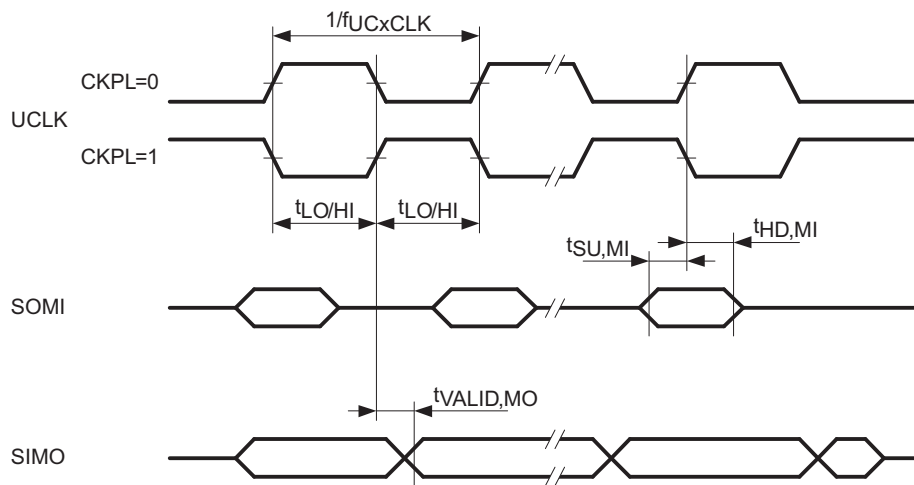

Figure 5. SPI Master Mode, CKPH = 1

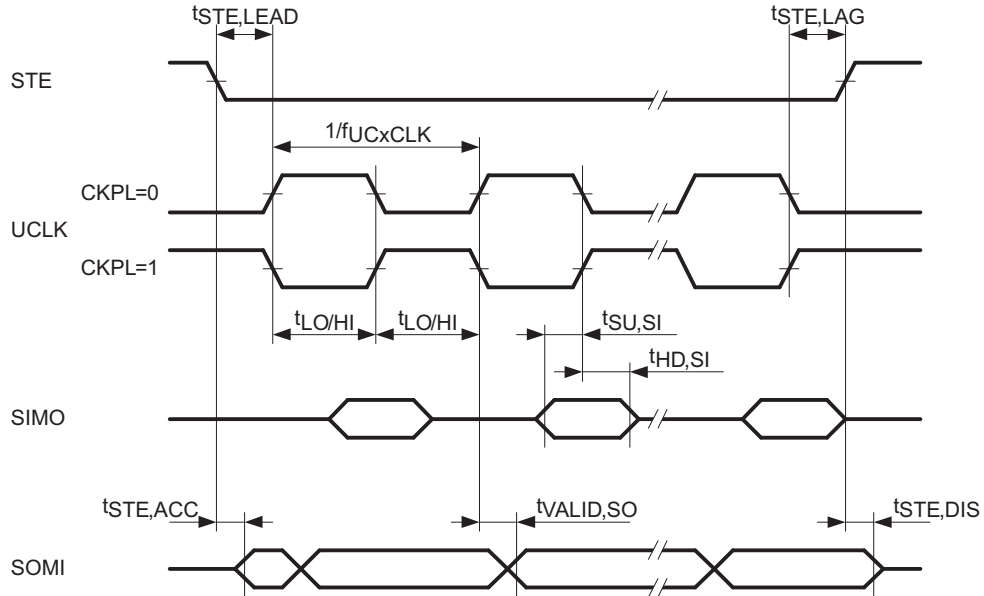

Figure 6. SPI Slave Mode, CKPH = 0

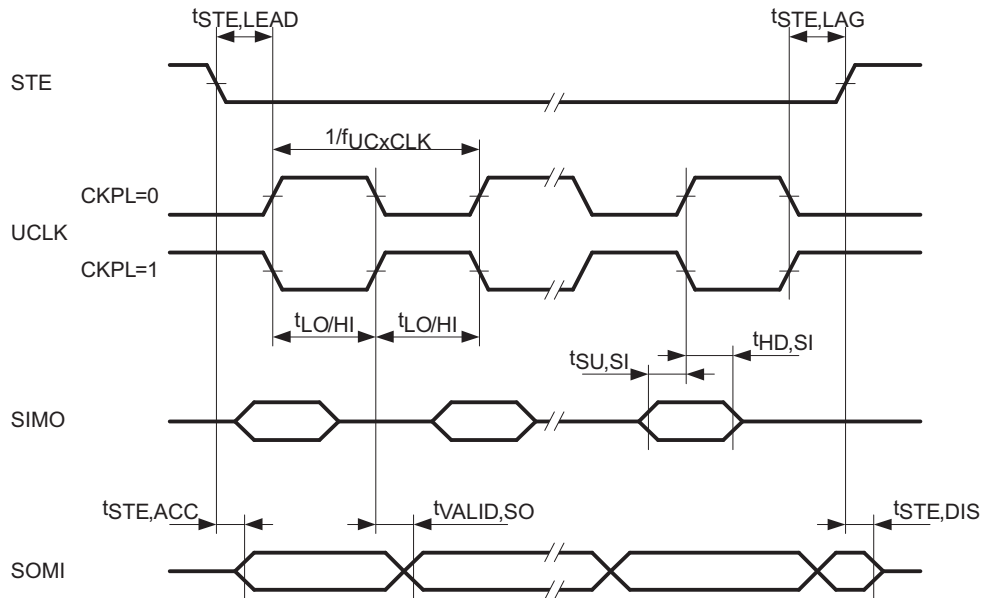

Figure 7. SPI Slave Mode, CKPH = 1

5.28 USCI (I2C Mode)

over recommended ranges of supply voltage and operating free-air temperature (unless otherwise noted) (see [Figure 8](#))

| PARAMETER | TEST CONDITIONS | V _{CC} | MIN | TYP | MAX | UNIT | |
|---------------------|---|--|--------------|------------|---------------------|------------|----|
| f _{USCI} | USCI input clock frequency | | | | f _{SYSTEM} | MHz | |
| f _{SCL} | SCL clock frequency | 2.2 V, 3 V | 0 | | 400 | kHz | |
| t _{HD,STA} | Hold time (repeated) START | f _{SCL} ≤ 100 kHz f _{SCL} > 100 kHz | 2.2 V, 3 V | 4 0.6 | | μs | |
| t _{SU,STA} | Setup time for a repeated START | f _{SCL} ≤ 100 kHz f _{SCL} > 100 kHz | 2.2 V, 3 V | 4.7 0.6 | | μs | |
| t _{HD,DAT} | Data hold time | | 2.2 V, 3 V | 0 | | ns | |
| t _{SU,DAT} | Data setup time | | 2.2 V, 3 V | 250 | | ns | |
| t _{SU,STO} | Setup time for STOP | | 2.2 V, 3 V | 4 | | μs | |
| t _{SP} | Pulse duration of spikes suppressed by input filter | | 2.2 V 3 V | 45 45 | 150 100 | 605 605 | ns |

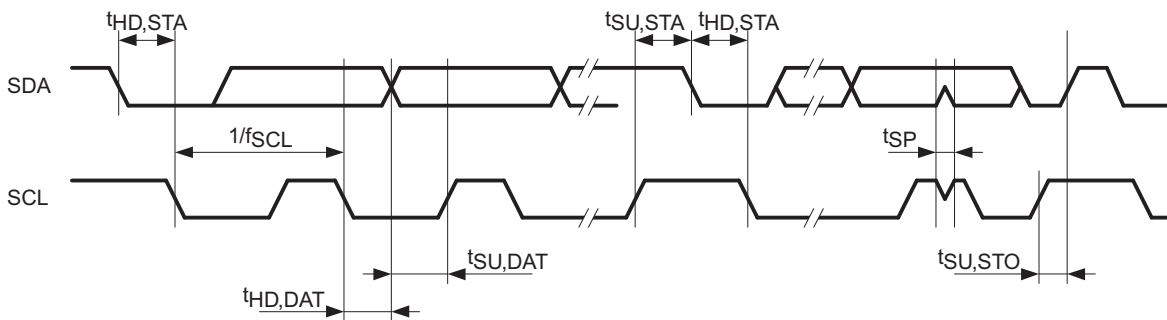

Figure 8. I2C Mode Timing

5.29 Comparator_A+⁽¹⁾

over recommended operating free-air temperature range (unless otherwise noted). See [Typical Characteristics - Comparator_A+](#) for related characterization graphs.

| PARAMETER | | TEST CONDITIONS | V _{CC} | MIN | TYP | MAX | UNIT |
|-----------------------------------|---|--|-----------------|-------|------|---------------------|------|
| I _(DD) | | CAON = 1, CARSEL = 0, CAREF = 0 | 2.2 V | | 25 | 45 | μA |
| | | | 3 V | | 45 | 65 | |
| I _(Refladder/RefDiode) | | CAON = 1, CARSEL = 0, CAREF = 1/2/3, No load at CA0 and CA1 | 2.2 V | | 30 | 55 | μA |
| | | | 3 V | | 45 | 85 | |
| V _{IC} | Common-mode input voltage range ⁽²⁾ | CAON = 1 | 2.2 V, 3 V | 0 | | V _{CC} - 1 | V |
| V _(Ref025) | Voltage at 0.25 V _{CC} node / V _{CC} | PCA0 = 1, CARSEL = 1, CAREF = 1, No load at CA0 and CA1 | 2.2 V, 3 V | 0.225 | 0.24 | 0.255 | |
| V _(Ref050) | Voltage at 0.5 V _{CC} node / V _{CC} | PCA0 = 1, CARSEL = 1, CAREF = 2, No load at CA0 and CA1 | 2.2 V, 3 V | 0.465 | 0.48 | 0.505 | |
| V _(RefVT) | See Figure 29 and Figure 30 | PCA0 = 1, CARSEL = 1, CAREF = 3, No load at CA0 and CA1, T _A = 85°C | 2.2 V | 360 | 480 | 570 | mV |
| | | | 3 V | 370 | 490 | 580 | |
| V _(offset) | Offset voltage ⁽³⁾ | | 2.2 V, 3 V | -42 | | 42 | mV |
| V _{hys} | Input hysteresis | CAON = 1 | 2.2 V, 3 V | | 0.7 | 1.8 | mV |
| t _(response) | Response time (low-high and high-low) | T _A = 25°C, Overdrive 10 mV, Without filter: CAF = 0 ⁽⁴⁾ (see Figure 9 and Figure 10) | 2.2 V | 100 | 165 | 320 | ns |
| | | | 3 V | 50 | 120 | 250 | |
| | | T _A = 25°C, Overdrive 10 mV, With filter: CAF = 1 ⁽⁴⁾ (see Figure 9 and Figure 10) | 2.2 V | 1.3 | 1.9 | 3.0 | μs |
| | | | 3 V | 0.7 | 1.5 | 2.5 | |

(1) The leakage current for the Comparator_A+ terminals is identical to I_{lk(Px.y)} specification.

(2) Not ensured for T_A > 105°C.

(3) The input offset voltage can be cancelled by using the CAEX bit to invert the Comparator_A+ inputs on successive measurements. The two successive measurements are then summed together.

(4) Response time measured at P2.2/TA0.0/A2/CA4/CAOUT. If the Comparator_A+ is enabled a settling time of 60 ns (typical) is added to the response time.

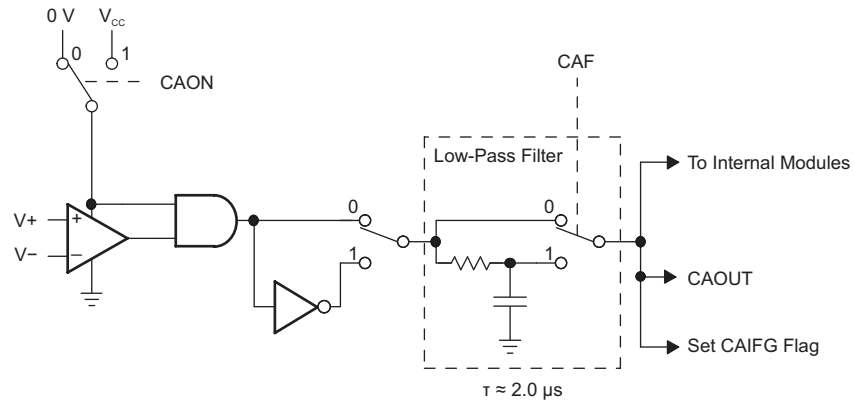

Figure 9. Comparator_A+ Module Block Diagram

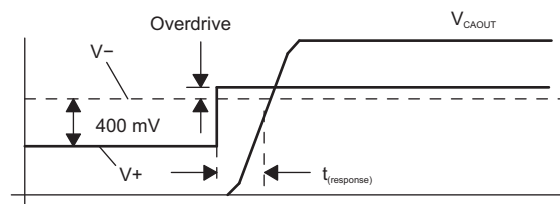

Figure 10. Overdrive Definition

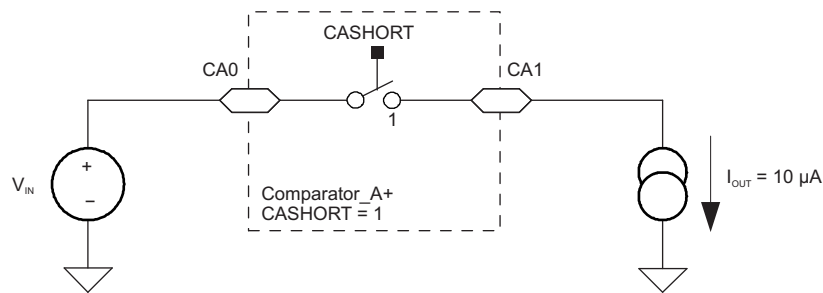

Figure 11. Comparator_A+ Short Resistance Test Condition

5.30 10-Bit ADC, Power Supply and Input Range Conditions⁽¹⁾

over recommended ranges of supply voltage and operating free-air temperature (unless otherwise noted)⁽¹⁾

| PARAMETER | TEST CONDITIONS | T _A | V _{CC} | MIN | TYP | MAX | UNIT |
|---------------------|--|---|-----------------|------------|------|-----------------|------|
| V _{CC} | Analog supply voltage | V _{SS} = 0 V | | 2.2 | | 3.6 | V |
| V _{Ax} | Analog input voltage range ⁽²⁾ | All Ax terminals, Analog inputs selected in ADC10AE register | | 0 | | V _{CC} | V |
| I _{ADC10} | ADC10 supply current ⁽³⁾ | f _{ADC10CLK} = 5 MHz, ADC10ON = 1, REFON = 0, ADC10SHT0 = 1, ADC10SHT1 = 0, ADC10DIV = 0 | -40°C to 85°C | 2.2 V | 0.52 | 1.06 | mA |
| | | | -40°C to 105°C | 3 V | 0.6 | 1.25 | |
| I _{REF+} | Reference supply current, reference buffer disabled ⁽⁴⁾ | f _{ADC10CLK} = 5 MHz, ADC10ON = 0, REF2_5V = 0, REFON = 1, REFOUT = 0 | -40°C to 85°C | 2.2 V, 3 V | 0.25 | 0.45 | mA |
| | | | -40°C to 105°C | 3 V | 0.25 | 0.45 | |
| I _{REFB,0} | Reference buffer supply current with ADC10SR = 0 ⁽⁴⁾ | f _{ADC10CLK} = 5 MHz, ADC10ON = 0, REFON = 1, REF2_5V = 0, REFOUT = 1, ADC10SR = 0 | -40°C to 85°C | 2.2 V, 3 V | 1.1 | 1.4 | mA |
| | | | 125°C | | 1.85 | | |
| I _{REFB,1} | Reference buffer supply current with ADC10SR = 1 ⁽⁴⁾ | f _{ADC10CLK} = 5 MHz, ADC10ON = 0, REFON = 1, REF2_5V = 0, REFOUT = 1, ADC10SR = 1 | -40°C to 85°C | 2.2 V, 3 V | 0.5 | 0.7 | mA |
| | | | 125°C | | 0.85 | | |
| C _I | Input capacitance | Only one terminal Ax selected at a time | | | | 27 | pF |
| R _I | Input MUX ON resistance | 0 V ≤ V _{Ax} ≤ V _{CC} | | | | 2000 | Ω |

- (1) The leakage current is defined in the leakage current table with P_{x.x}/A_x parameter.
- (2) The analog input voltage range must be within the selected reference voltage range V_{R+} to V_{R-} for valid conversion results.
- (3) The internal reference supply current is not included in current consumption parameter I_{ADC10}.
- (4) The internal reference current is supplied via terminal V_{CC}. Consumption is independent of the ADC10ON control bit, unless a conversion is active. The REFON bit enables the built-in reference. The reference voltage must be allowed to settle before an A/D conversion is started.

5.31 10-Bit ADC, Built-In Voltage Reference

over recommended ranges of supply voltage and operating free-air temperature (unless otherwise noted)

| PARAMETER | | TEST CONDITIONS | | V _{CC} | MIN | TYP | MAX | UNIT |
|--|--|---|----------------|-----------------|------|-----|------|--------|
| V _{CC,REF+} | Positive built-in reference analog supply voltage range | I _{VREF+} ≤ 1 mA, REF2_5V = 0 | | | 2.2 | | | V |
| | | I _{VREF+} ≤ 0.5 mA, REF2_5V = 1 | | | 2.8 | | | |
| | | I _{VREF+} ≤ 1 mA, REF2_5V = 1 | | | 2.9 | | | |
| V _{REF+} | Positive built-in reference voltage | I _{VREF+} ≤ I _{VREF+,max} , REF2_5V = 0 | | 2.2 V, 3 V | 1.40 | 1.5 | 1.60 | V |
| | | I _{VREF+} ≤ I _{VREF+,max} , REF2_5V = 1 | | 3 V | 2.30 | 2.5 | 2.70 | |
| I _{LD,VREF+} | Maximum V _{REF+} load current | | | 2.2 V | ±0.5 | | | mA |
| | | | | 3 V | ±1 | | | |
| V _{REF+} load regulation | V _{REF+} load regulation | I _{VREF+} = 500 μA ± 100 μA, Analog input voltage V _{AX} ≈ 0.75 V, REF2_5V = 0 | | 2.2 V, 3 V | ±2 | | | LSB |
| | | I _{VREF+} = 500 μA ± 100 μA, Analog input voltage V _{AX} ≈ 1.25 V, REF2_5V = 1 | | 3 V | ±2 | | | |
| V _{REF+} load regulation response time ⁽¹⁾ | V _{REF+} load regulation response time ⁽¹⁾ | I _{VREF+} = 100 μA to 900 μA, V _{AX} ≈ 0.5 × V _{REF+} , Error of conversion result ≤ 1 LSB | ADC10SR = 0 | 3 V | 400 | | | ns |
| | | | ADC10SR = 1 | | 2000 | | | |
| C _{VREF+} | Maximum capacitance at pin V _{REF+} ⁽²⁾ | I _{VREF+} ≤ ±1 mA, REFON = 1, REFOUT = 1 | | 2.2 V, 3 V | 100 | | | pF |
| TC _{REF+} | Temperature coefficient ⁽³⁾ | I _{VREF+} = constant with 0 mA ≤ I _{VREF+} ≤ 1 mA ⁽⁴⁾ | -40°C to 85°C | 2.2 V, 3 V | ±100 | | | ppm/°C |
| | | | -40°C to 105°C | | ±110 | | | |
| t _{REFON} | Settling time of internal reference voltage ⁽¹⁾⁽⁵⁾ | I _{VREF+} = 0.5 mA, REF2_5V = 0, REFON = 0 to 1 | | 3.6 V | 30 | | | μs |
| t _{REFBURST} | Settling time of reference buffer ⁽¹⁾⁽⁵⁾ | I _{VREF+} = 0.5 mA, REF2_5V = 0, REFON = 1, REFBURST = 1 | ADC10SR = 0 | 2.2 V | 1 | | | μs |
| | | | ADC10SR = 1 | | 2.5 | | | |
| | | I _{VREF+} = 0.5 mA, REF2_5V = 1, REFON = 1, REFBURST = 1 | ADC10SR = 0 | 3 V | 2 | | | |
| | | | ADC10SR = 1 | | 4.5 | | | |

(1) Not ensured for T_A > 105°C.

(2) The capacitance applied to the internal buffer operational amplifier, if switched to terminal P2.4/TA2/A4/V_{REF+}/V_{eREF+} (REFOUT = 1), must be limited; otherwise, the reference buffer may become unstable.

(3) Calculated using the box method:

I temperature: (MAX(-40 to 85°C) – MIN(-40 to 85°C)) / MIN(-40 to 85°C) / (85°C – (-40°C))

T temperature: (MAX(-40 to 105°C) – MIN(-40 to 105°C)) / MIN(-40 to 105°C) / (105°C – (-40°C))

(4) Calculated using the box method: ((MAX(V_{REF}(T)) – MIN(V_{REF}(T))) / MIN(V_{REF}(T))) / (T_{MAX} – T_{MIN})

(5) The condition is that the error in a conversion started after t_{REFON} or t_{RefBuf} is less than ±0.5 LSB.

5.32 10-Bit ADC, External Reference⁽¹⁾

over recommended ranges of supply voltage and operating free-air temperature (unless otherwise noted)

| PARAMETER | | TEST CONDITIONS | V _{CC} | MIN | MAX | UNIT |
|---------------------|---|--|-----------------|-----|-----------------|------|
| V _{eREF+} | Positive external reference input voltage range ⁽²⁾ | V _{eREF+} > V _{eREF-} , SREF1 = 1, SREF0 = 0 | | 1.4 | V _{CC} | V |
| | | V _{eREF-} ≤ V _{eREF+} ≤ (V _{CC} - 0.15 V), SREF1 = 1, SREF0 = 1 ⁽³⁾ | | 1.4 | 3 | |
| V _{eREF-} | Negative external reference input voltage range ⁽⁴⁾ | V _{eREF+} > V _{eREF-} | | 0 | 1.2 | V |
| ΔV _{eREF} | Differential external reference input voltage range ΔV _{eREF} = V _{eREF+} - V _{eREF-} | V _{eREF+} > V _{eREF-} ⁽⁵⁾ | | 1.4 | V _{CC} | V |
| I _{VeREF+} | Static input current into V _{eREF+} ⁽⁶⁾ | 0 V ≤ V _{eREF+} ≤ V _{CC} , SREF1 = 1, SREF0 = 0 | 2.2 V, 3 V | ±1 | | μA |
| | | 0 V ≤ V _{eREF+} ≤ V _{CC} - 0.15 V ≤ 3 V, SREF1 = 1, SREF0 = 1 ⁽³⁾ | | 0 | | |
| I _{VeREF-} | Static input current into V _{eREF-} ⁽⁶⁾ | 0 V ≤ V _{eREF-} ≤ V _{CC} | 2.2 V, 3 V | ±1 | | μA |

- (1) The external reference is used during conversion to charge and discharge the capacitance array. The input capacitance, C_I, is also the dynamic load for an external reference during conversion. The dynamic impedance of the reference supply should follow the recommendations on analog-source impedance to allow the charge to settle for 10-bit accuracy.
- (2) The accuracy limits the minimum positive external reference voltage. Lower reference voltage levels may be applied with reduced accuracy requirements.
- (3) Under this condition, the external reference is internally buffered. The reference buffer is active and requires the reference buffer supply current I_{REFB}. The current consumption can be limited to the sample and conversion period with REBURST = 1.
- (4) The accuracy limits the maximum negative external reference voltage. Higher reference voltage levels may be applied with reduced accuracy requirements.
- (5) The accuracy limits the minimum external differential reference voltage. Lower differential reference voltage levels may be applied with reduced accuracy requirements.
- (6) Not ensured for T_A > 105°C.

5.33 10-Bit ADC, Timing Parameters

over recommended ranges of supply voltage and operating free-air temperature (unless otherwise noted)

| PARAMETER | | TEST CONDITIONS | V _{CC} | MIN | TYP | MAX | UNIT |
|-----------------------|---|---|-----------------|------|---|------|------|
| f _{ADC10CLK} | ADC10 input clock frequency | For specified performance of ADC10 linearity parameters | 2.2 V, 3 V | 0.45 | | 6.3 | MHz |
| | | | | 0.45 | | 1.5 | |
| f _{ADC10OSC} | ADC10 built-in oscillator frequency | ADC10DIVx = 0, ADC10SSELx = 0, f _{ADC10CLK} = f _{ADC10OSC} | 2.2 V, 3 V | 3.7 | | 6.3 | MHz |
| t _{CONVERT} | Conversion time | ADC10 built-in oscillator, ADC10SSELx = 0, f _{ADC10CLK} = f _{ADC10OSC} | 2.2 V, 3 V | 2.06 | | 4.00 | μs |
| | | f _{ADC10CLK} from ACLK, MCLK or SMCLK, ADC10SSELx ≠ 0 | | | 13 × ADC10DIVx × 1 / f _{ADC10CLK} | | |
| t _{ADC10ON} | Turn on settling time of the ADC ⁽¹⁾ | See ⁽²⁾ | | | | 100 | ns |

- (1) Not ensured for T_A > 105°C.
- (2) The condition is that the error in a conversion started after t_{ADC10ON} is less than ±0.5 LSB. The reference and input signal are already settled.

5.34 10-Bit ADC, Linearity Parameters

over recommended ranges of supply voltage and operating free-air temperature (unless otherwise noted)

| PARAMETER | | TEST CONDITIONS | V _{CC} | MIN | TYP | MAX | UNIT |
|----------------|------------------------------|--|-----------------|-----|------|------|------|
| E _I | Integral linearity error | | 2.2 V, 3 V | | | ±1.2 | LSB |
| E _D | Differential linearity error | | 2.2 V, 3 V | | | ±1.2 | LSB |
| E _O | Offset error | Source impedance R _S < 100 Ω | 2.2 V, 3 V | | | ±1.2 | LSB |
| E _G | Gain error | SREFx = 010, unbuffered external reference, V _{eREF+} = 1.5 V | 2.2 V | | ±1.1 | ±2 | LSB |
| | | SREFx = 010, unbuffered external reference, V _{eREF+} = 2.5 V | 3 V | | ±1.1 | ±2 | |
| | | SREFx = 011, buffered external reference ⁽¹⁾ , V _{eREF+} = 1.5 V | 2.2 V | | ±1.1 | ±4.5 | |
| | | SREFx = 011, buffered external reference ⁽¹⁾ , V _{eREF+} = 2.5 V | 3 V | | ±1.1 | ±3.5 | |
| E _T | Total unadjusted error | SREFx = 010, unbuffered external reference, V _{eREF+} = 1.5 V | 2.2 V | | ±2 | ±5 | LSB |
| | | SREFx = 010, unbuffered external reference, V _{eREF+} = 2.5 V | 3 V | | ±2 | ±5 | |
| | | SREFx = 011, buffered external reference ⁽¹⁾ , V _{eREF+} = 1.5 V | 2.2 V | | ±2 | ±7.5 | |
| | | SREFx = 011, buffered external reference ⁽¹⁾ , V _{eREF+} = 2.5 V | 3 V | | ±2 | ±6.5 | |

(1) The reference buffer offset adds to the gain and total unadjusted error.

5.35 10-Bit ADC, Temperature Sensor and Built-In V_{MID}⁽¹⁾

over recommended ranges of supply voltage and operating free-air temperature (unless otherwise noted)

| PARAMETER | | TEST CONDITIONS | V _{CC} | MIN | TYP | MAX | UNIT | |
|-----------------------------|---|---|-----------------|------|------|--------------------|-------|----|
| I _{SENSOR} | Temperature sensor supply current ⁽¹⁾ | REFON = 0, INCHx = 0Ah, ADC10ON = 1, T _A = 25°C | 2.2 V | | 40 | 120 | μA | |
| | | | 3 V | | 60 | 160 | | |
| TC _{SENSOR} | | ADC10ON = 1, INCHx = 0Ah ⁽²⁾ | 2.2 V, 3 V | | 3.55 | | mV/°C | |
| V _{Offset, Sensor} | Sensor offset voltage ⁽³⁾ | ADC10ON = 1, INCHx = 0Ah ⁽²⁾ | | -100 | | +100 | mV | |
| V _{SENSOR} | Sensor output voltage ⁽⁴⁾ | Temperature sensor voltage at T _A = 125°C (Q version only) | 2.2 V, 3 V | | 1205 | 1365 | 1465 | mV |
| | | Temperature sensor voltage at T _A = 85°C | | | 1195 | 1295 | 1395 | |
| | | Temperature sensor voltage at T _A = 25°C | | | 985 | 1085 | 1185 | |
| | | Temperature sensor voltage at T _A = 0°C | | | 895 | 995 | 1095 | |
| t _{SENSOR(sample)} | Sample time required if channel 10 is selected ⁽⁵⁾ | ADC10ON = 1, INCHx = 0Ah, Error of conversion result ≤ 1 LSB | 2.2 V, 3 V | 31 | | | μs | |
| I _{VMID} | Current into divider at channel 11 ⁽⁵⁾ | ADC10ON = 1, INCHx = 0Bh | 2.2 V | | | N/A ⁽⁵⁾ | μA | |
| | | | 3 V | | | N/A ⁽⁵⁾ | | |
| V _{MID} | V _{CC} divider at channel 11 | ADC10ON = 1, INCHx = 0Bh, V _{MID} ≈ 0.5 × V _{CC} | 2.2 V | 1.05 | 1.1 | 1.15 | V | |
| | | | 3 V | 1.45 | 1.5 | 1.55 | | |
| t _{VMID(sample)} | Sample time required if channel 11 is selected ⁽⁶⁾ | ADC10ON = 1, INCHx = 0Bh, Error of conversion result ≤ 1 LSB | 2.2 V | 1600 | | | ns | |
| | | | 3 V | 1600 | | | | |

- The sensor current I_{SENSOR} is consumed if (ADC10ON = 1 and REFON = 1) or (ADC10ON = 1 and INCH = 0Ah and sample signal is high). When REFON = 1, I_{SENSOR} is included in I_{REF+}. When REFON = 0, I_{SENSOR} applies during conversion of the temperature sensor input (INCH = 0Ah).
- The following formula can be used to calculate the temperature sensor output voltage:

$$V_{\text{Sensor, typ}} = TC_{\text{Sensor}} (273 + T [^{\circ}\text{C}]) + V_{\text{Offset, sensor}} [\text{mV}] \text{ or}$$

$$V_{\text{Sensor, typ}} = TC_{\text{Sensor}} T [^{\circ}\text{C}] + V_{\text{Sensor}}(T_A = 0^{\circ}\text{C}) [\text{mV}]$$
- Not ensured for T_A > 105°C.
- Results based on characterization and/or production test, not TC_{Sensor} or V_{Offset, sensor}.
- No additional current is needed. The V_{MID} is used during sampling.
- The on time, t_{VMID(on)}, is included in the sampling time, t_{VMID(sample)}; no additional on time is needed.

5.36 Flash Memory⁽¹⁾

over recommended ranges of supply voltage and operating free-air temperature (unless otherwise noted)

| PARAMETER | | TEST CONDITIONS | V _{CC} | MIN | TYP | MAX | UNIT |
|-----------------------------|---|-----------------------|-----------------|-----------------|-----------------|-----|------------------|
| V _{CC (PGM/ERASE)} | Program and erase supply voltage | | | 2.2 | | 3.6 | V |
| f _{FTG} | Flash timing generator frequency | | | 257 | | 476 | kHz |
| I _{PGM} | Supply current from V _{CC} during program ⁽²⁾ | | 2.2 V/3.6 V | | 1 | 5 | mA |
| I _{ERASE} | Supply current from V _{CC} during erase ⁽²⁾ | | 2.2 V/3.6 V | | 1 | 7 | mA |
| t _{CPT} | Cumulative program time ⁽²⁾⁽³⁾ | | 2.2 V/3.6 V | | | 10 | ms |
| t _{CMErase} | Cumulative mass erase time ⁽²⁾ | | 2.2 V/3.6 V | 20 | | | ms |
| | Program and erase endurance ⁽²⁾ | | | 10 ⁴ | 10 ⁵ | | cycles |
| t _{Retention} | Data retention duration | T _J = 25°C | | 100 | | | years |
| t _{Word} | Word or byte program time | See ⁽⁴⁾ | | | 30 | | t _{FTG} |
| t _{Block, 0} | Block program time for first byte or word | See ⁽⁴⁾ | | | 25 | | t _{FTG} |
| t _{Block, 1-63} | Block program time for each additional byte or word | See ⁽⁴⁾ | | | 18 | | t _{FTG} |
| t _{Block, End} | Block program end-sequence wait time | See ⁽⁴⁾ | | | 6 | | t _{FTG} |
| t _{Mass Erase} | Mass erase time | See ⁽⁴⁾ | | | 10593 | | t _{FTG} |
| t _{Seg Erase} | Segment erase time | See ⁽⁴⁾ | | | 4819 | | t _{FTG} |

(1) Additional flash retention documentation located in application report [SLAA392](#).

(2) Not ensured for T_A > 105°C.

(3) The cumulative program time must not be exceeded when writing to a 64-byte flash block. This parameter applies to all programming methods: individual word/byte write and block write modes.

(4) These values are hardwired into the flash controller's state machine (t_{FTG} = 1/f_{FTG}).

5.37 RAM

over recommended ranges of supply voltage and operating free-air temperature (unless otherwise noted)

| PARAMETER | | TEST CONDITIONS | MIN | MAX | UNIT |
|---------------------|---|-----------------|-----|-----|------|
| V _(RAMh) | RAM retention supply voltage ⁽¹⁾ | CPU halted | 1.6 | | V |

(1) This parameter defines the minimum supply voltage V_{CC} when the data in RAM remains unchanged. No program execution should happen during this supply voltage condition.

5.38 JTAG and Spy-Bi-Wire Interface

over recommended ranges of supply voltage and operating free-air temperature (unless otherwise noted)

| PARAMETER | | TEST CONDITIONS | V _{CC} | MIN | TYP | MAX | UNIT |
|-----------------------|--|---------------------------------|-----------------|-------|-----|-----|------|
| f _{SBW} | Spy-Bi-Wire input frequency | T _A = -40°C to 105°C | 2.2 V, 3 V | 0 | | 20 | MHz |
| t _{SBW,Low} | Spy-Bi-Wire low clock pulse duration | T _A = -40°C to 105°C | 2.2 V, 3 V | 0.025 | | 15 | μs |
| t _{SBW,En} | Spy-Bi-Wire enable time (TEST high to acceptance of first clock edge ⁽¹⁾) | T _A = -40°C to 105°C | 2.2 V, 3 V | | | 1 | μs |
| t _{SBW,Ret} | Spy-Bi-Wire return to normal operation time | T _A = -40°C to 105°C | 2.2 V, 3 V | 15 | | 100 | μs |
| f _{TCK} | TCK input frequency ⁽²⁾ | T _A = -40°C to 105°C | 2.2 V | 0 | | 5 | MHz |
| | | | 3 V | 0 | | 10 | MHz |
| R _{Internal} | Internal pulldown resistance on TEST | T _A = -40°C to 105°C | 2.2 V, 3 V | 25 | 60 | 90 | kΩ |

- (1) Tools accessing the Spy-Bi-Wire interface need to wait for the maximum t_{SBW,En} time after pulling the TEST/SBWCLK pin high before applying the first SBWCLK clock edge.
- (2) f_{TCK} may be restricted to meet the timing requirements of the module selected.

5.39 JTAG Fuse⁽¹⁾

over recommended ranges of supply voltage and operating free-air temperature (unless otherwise noted)

| PARAMETER | | TEST CONDITIONS | MIN | MAX | UNIT |
|---------------------|---|-----------------------|-----|-----|------|
| V _{CC(FB)} | Supply voltage during fuse-blow condition | T _A = 25°C | 2.5 | | V |
| V _{FB} | Voltage level on TEST for fuse blow | T _A = 25°C | 6 | 7 | V |
| I _{FB} | Supply current into TEST during fuse blow | T _A = 25°C | | 100 | mA |
| t _{FB} | Time to blow fuse | T _A = 25°C | | 1 | ms |

- (1) Once the fuse is blown, no further access to the JTAG/Test and emulation features is possible, and the JTAG block is switched to bypass mode.

5.40 Typical Characteristics - Active-Mode Supply Current (Into DV_{CC} + AV_{CC})

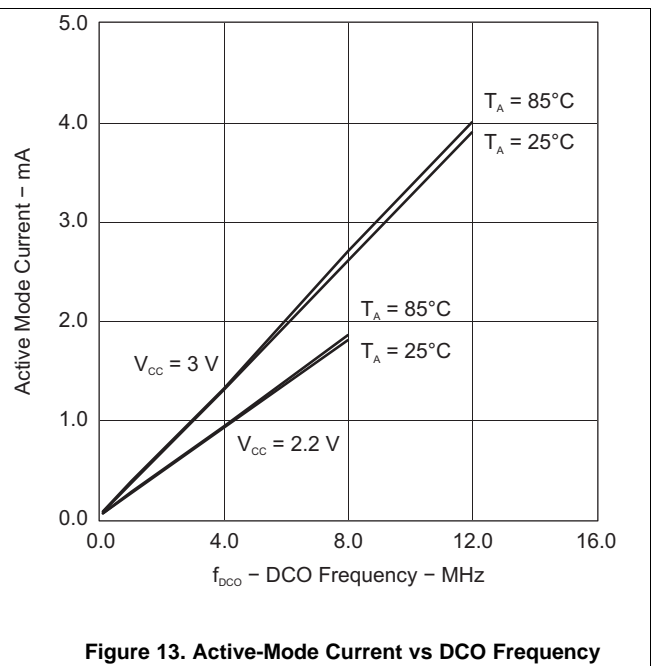
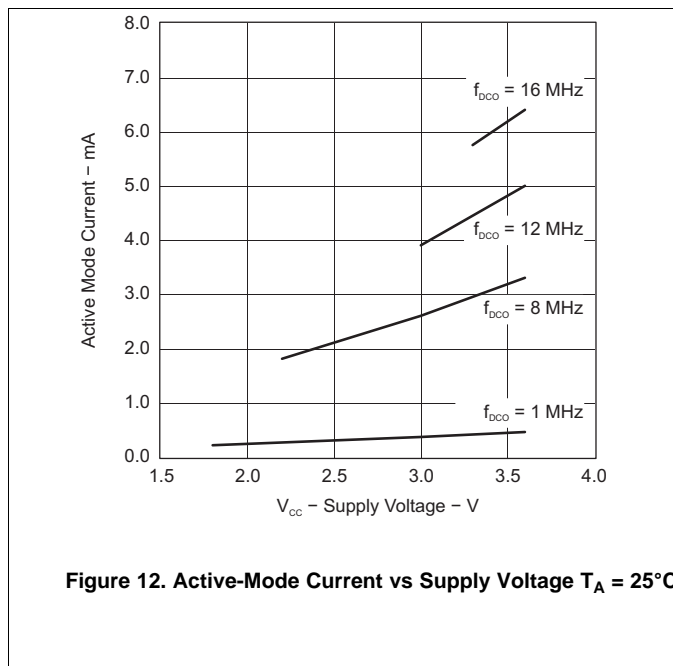

5.41 Typical Characteristics - LPM4 Current

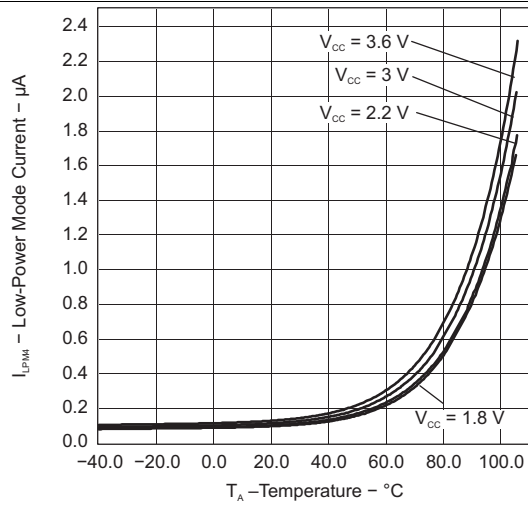

Figure 14. LPM4 Current vs Temperature

5.42 Typical Characteristics - Outputs

One output loaded at a time.

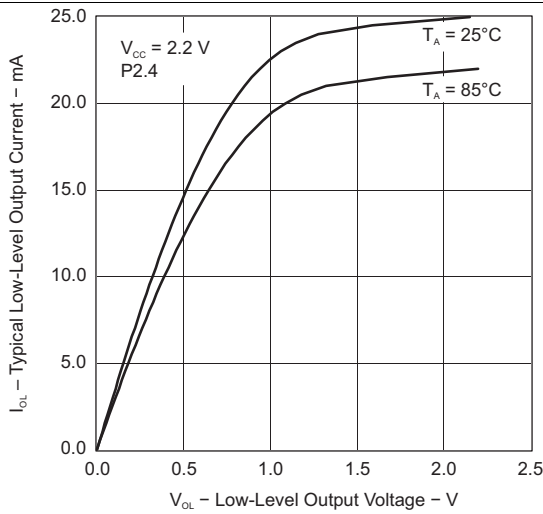

Figure 15. Typical Low-Level Output Current vs Low-Level Output Voltage

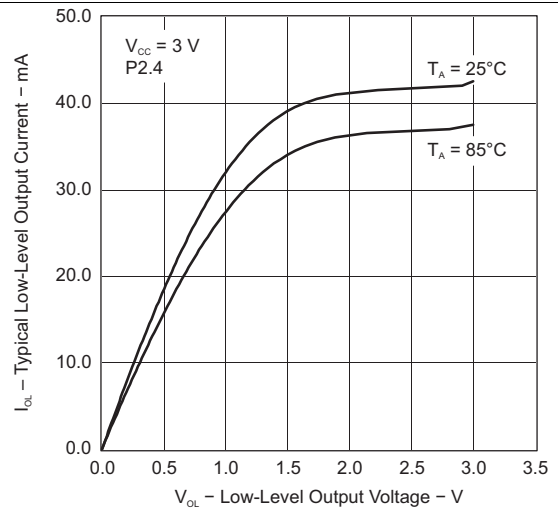

Figure 16. Typical Low-Level Output Current vs Low-Level Output Voltage

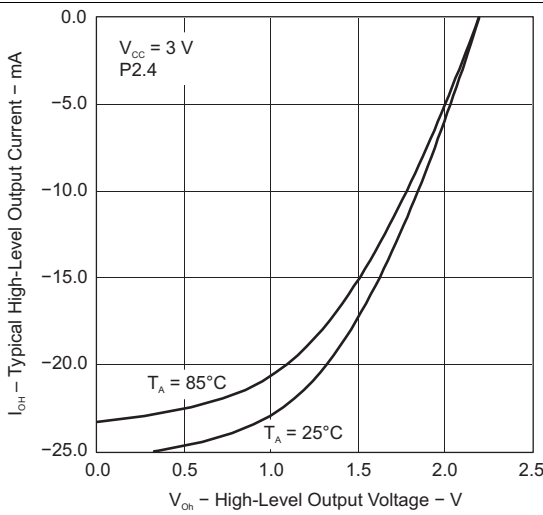

Figure 17. Typical High-Level Output Current vs High-Level Output Voltage

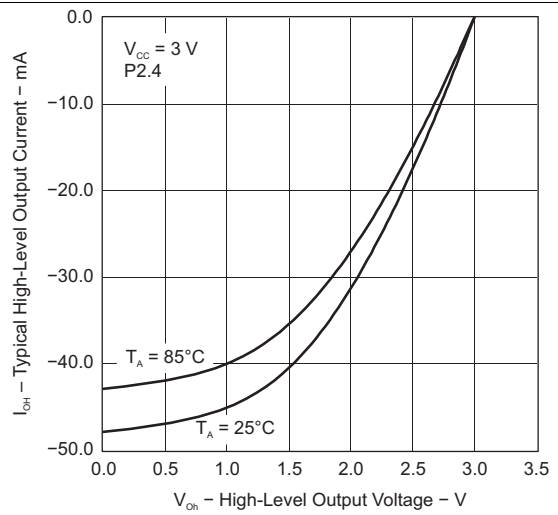
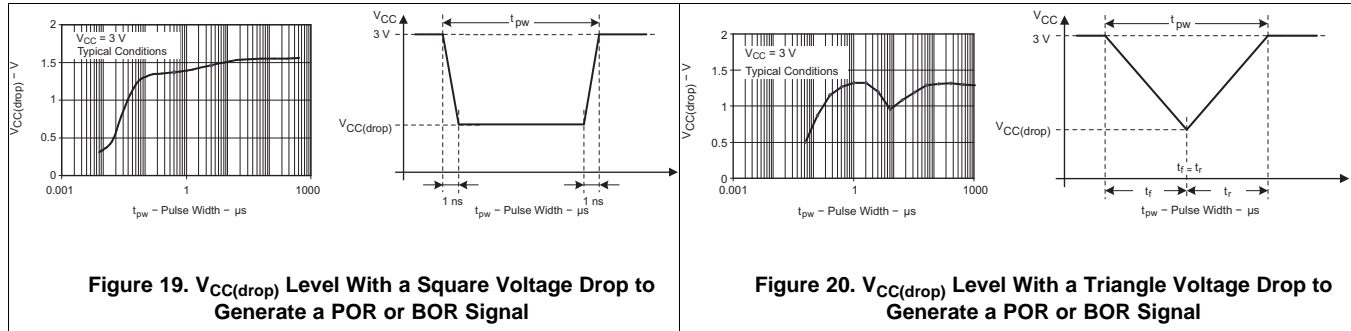
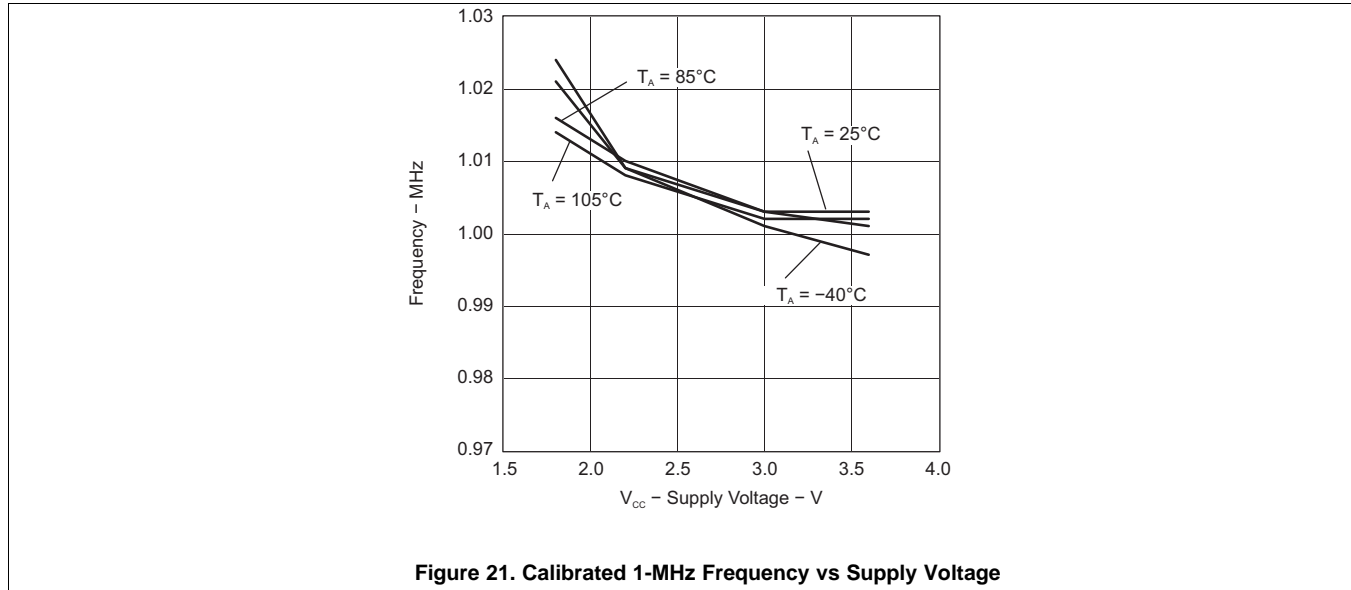

Figure 18. Typical High-Level Output Current vs High-Level Output Voltage

5.43 Typical Characteristics - POR/Brownout Reset (BOR)



5.44 Typical Characteristics - Calibrated 1-MHz DCO Frequency



5.45 Typical Characteristics - DCO Clock Wake-Up Time From LPM3/4

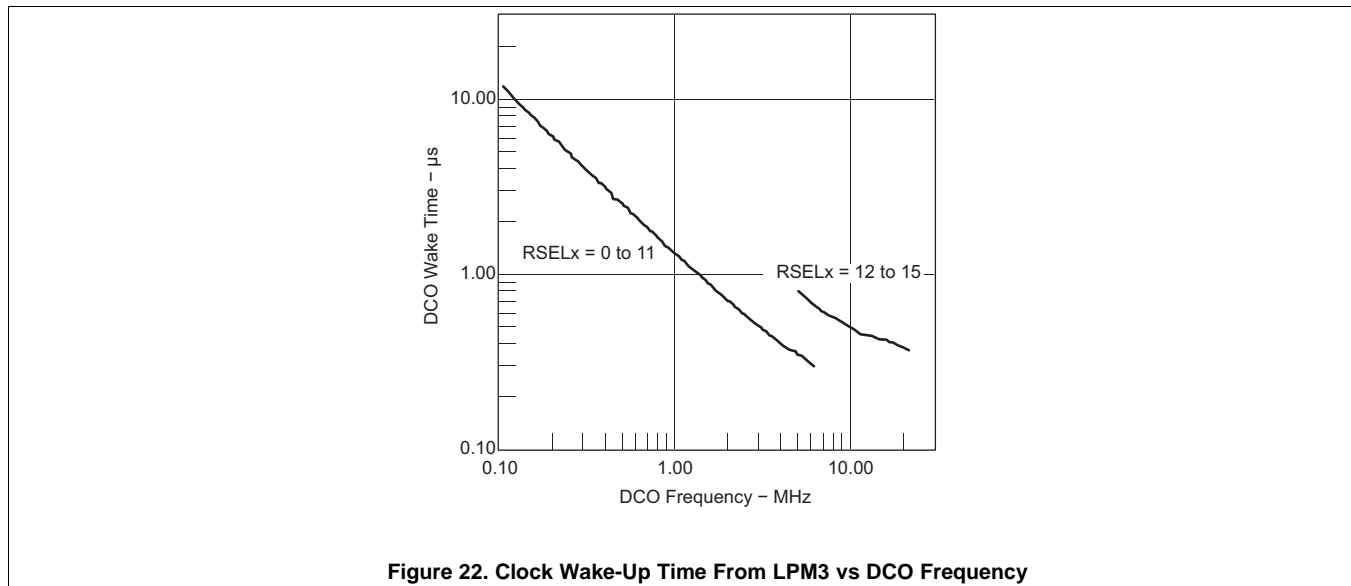

5.46 Typical Characteristics - DCO With External Resistor R_{OSC}

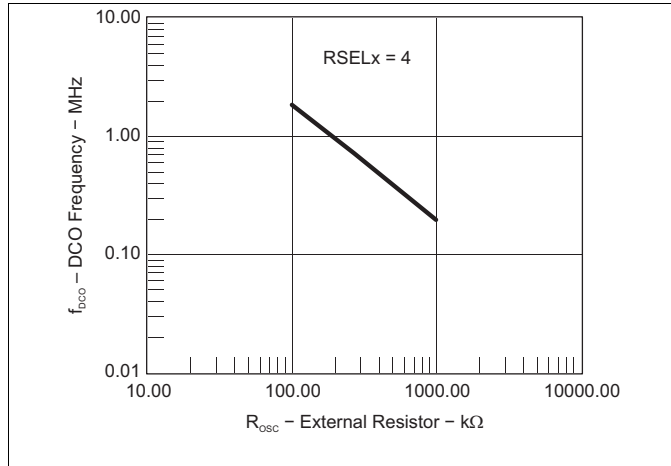

Figure 23. DCO Frequency vs R_{OSC} $V_{CC} = 2.2\text{ V}$, $T_A = 25^\circ\text{C}$

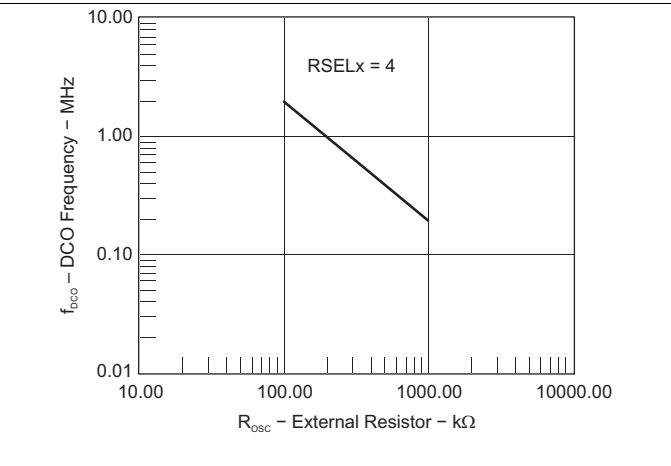

Figure 24. DCO Frequency vs R_{OSC} $V_{CC} = 3\text{ V}$, $T_A = 25^\circ\text{C}$

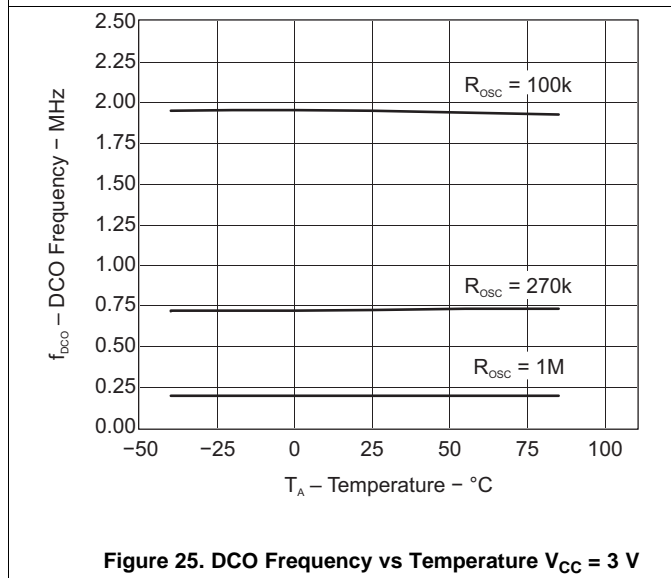

Figure 25. DCO Frequency vs Temperature $V_{CC} = 3\text{ V}$

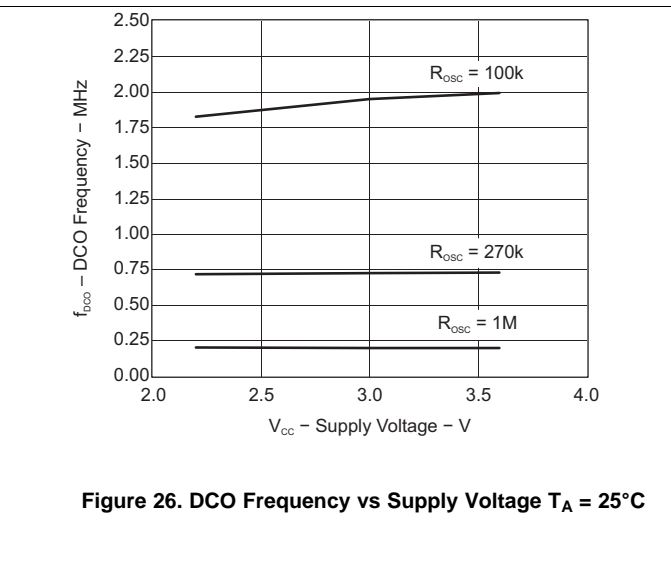
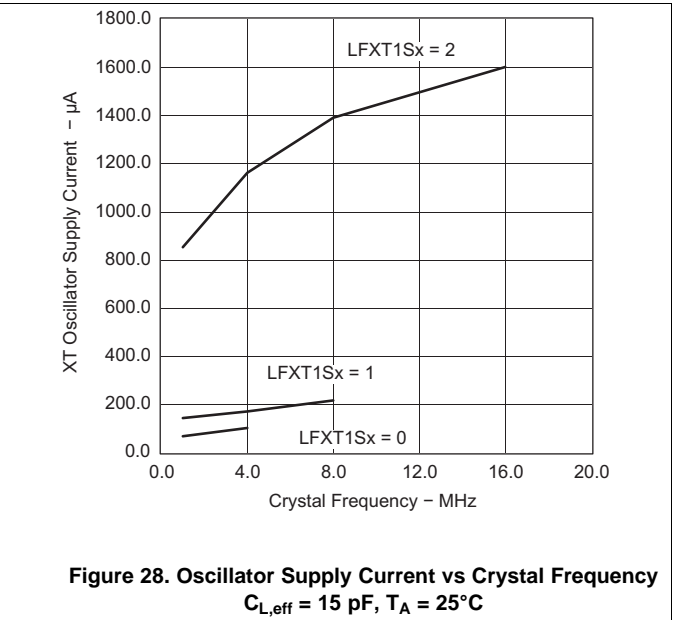
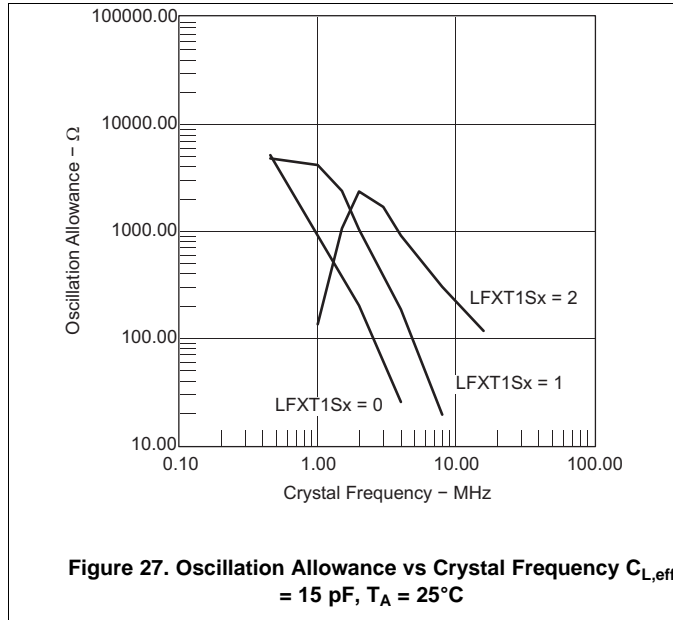

Figure 26. DCO Frequency vs Supply Voltage $T_A = 25^\circ\text{C}$

5.47 Typical Characteristics - LFXT1 Oscillator in HF Mode (XTS = 1)



5.48 Typical Characteristics - Comparator_A+

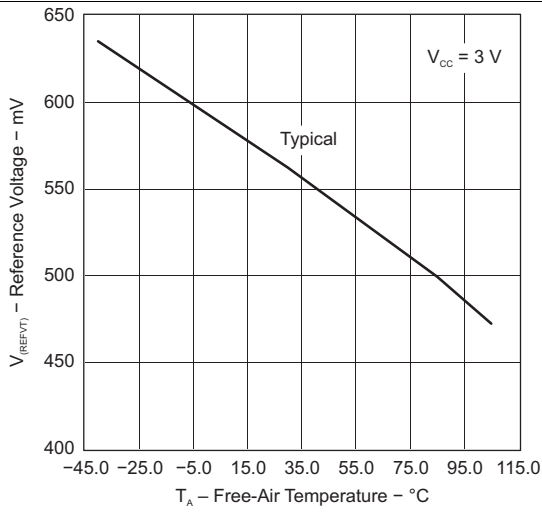

Figure 29. $V_{(RefVT)}$ vs Temperature $V_{CC} = 2.2 V$

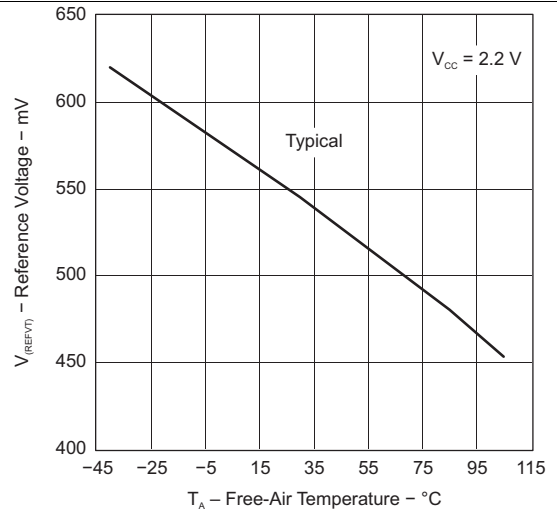

Figure 30. $V_{(RefVT)}$ vs Temperature $V_{CC} = 2.2 V$

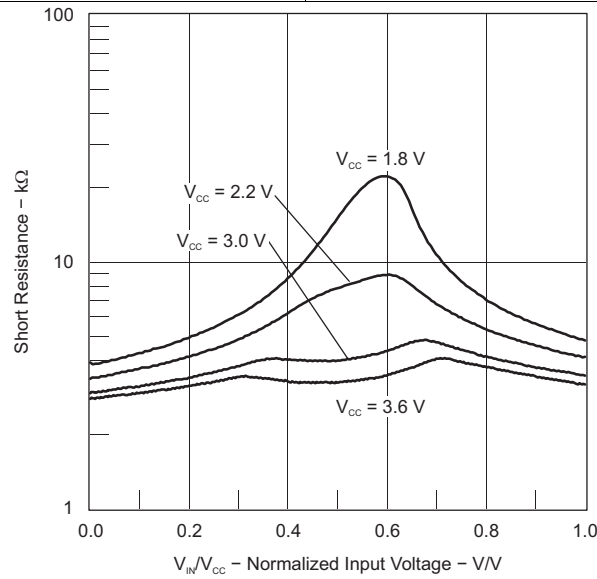

Figure 31. Short Resistance vs V_{IN}/V_{CC}

6 Application Information

6.1 Port P1 Pin Schematic: P1.0, Input/Output With Schmitt Trigger

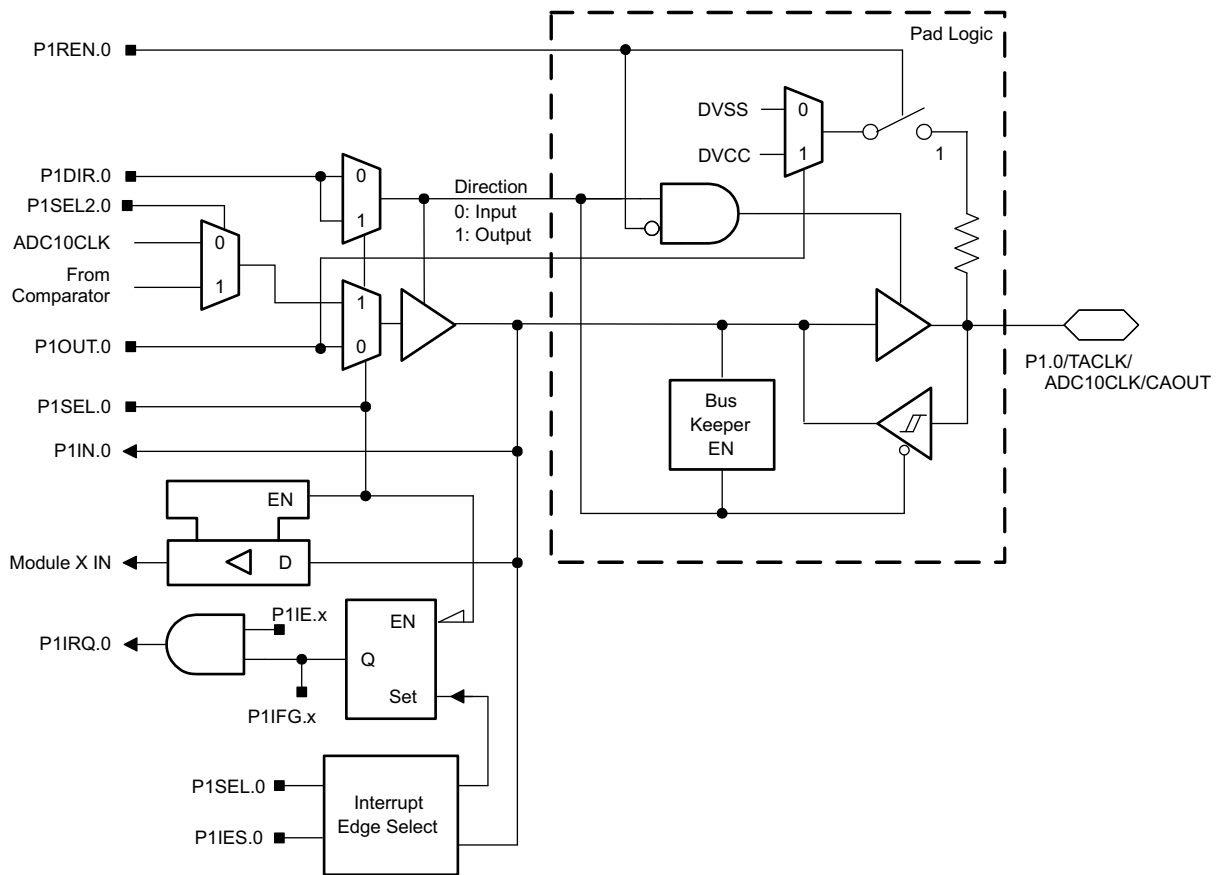

Table 16. Port P1 (P1.0) Pin Functions

| PIN NAME (P1.x) | x | FUNCTION | CONTROL BITS AND SIGNALS | | |
|-------------------------------|---|----------------------------------|--------------------------|---------|----------|
| | | | P1DIR.x | P1SEL.x | P1SEL2.x |
| P1.0/TACLK/ ADC10CLK/CAOUT | 0 | P1.0 (I/O) | I: 0, O: 1 | 0 | 0 |
| | | Timer0_A3.TACLK, Timer1_A2.TACLK | 0 | 1 | 0 |
| | | ADC10CLK | 1 | 1 | 0 |
| | | CAOUT | 1 | 1 | 1 |

6.2 Port P1 Pin Schematic: P1.1 to P1.3, Input/Output With Schmitt Trigger

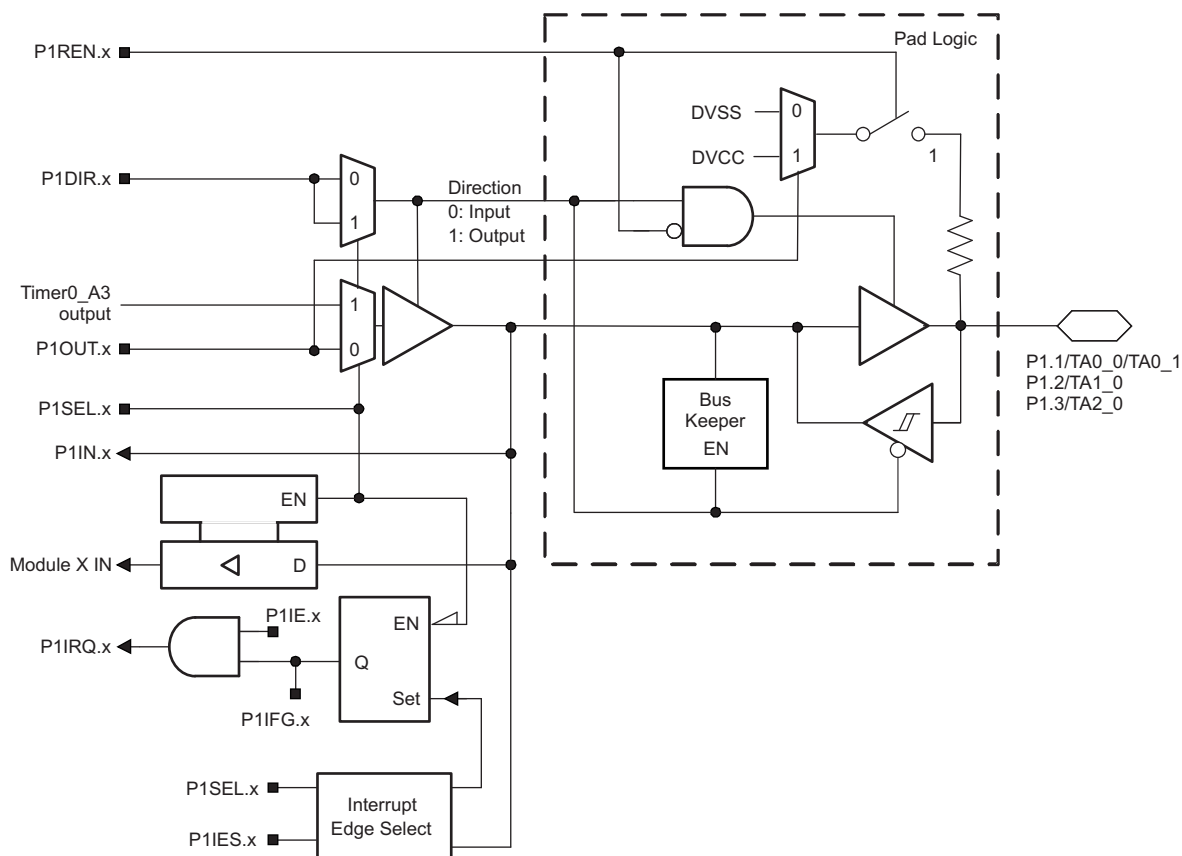

Table 17. Port P1 (P1.1 to P1.3) Pin Functions

| PIN NAME (P1.x) | x | FUNCTION | CONTROL BITS AND SIGNALS | | |
|------------------|---|----------------------------------|--------------------------|---------|----------|
| | | | P1DIR.x | P1SEL.x | P1SEL2.x |
| P1.1/TA0.0/TA1.0 | 1 | P1.1 (I/O) | I: 0; O: 1 | 0 | 0 |
| | | Timer0_A3.CCI0A, Timer1_A2.CCI0A | 0 | 1 | 0 |
| | | Timer0_A3.TA0 | 1 | 1 | 0 |
| P1.2/TA0.1 | 2 | P1.2 (I/O) | I: 0; O: 1 | 0 | 0 |
| | | Timer0_A3.CCI1A | 0 | 1 | 0 |
| | | Timer0_A3.TA1 | 1 | 1 | 0 |
| P1.3/TA0.2 | 3 | P1.3 (I/O) | I: 0; O: 1 | 0 | 0 |
| | | Timer0_A3.CCI2A | 0 | 1 | 0 |
| | | Timer0_A3.TA2 | 1 | 1 | 0 |

6.3 Port P1 Pin Schematic: P1.4

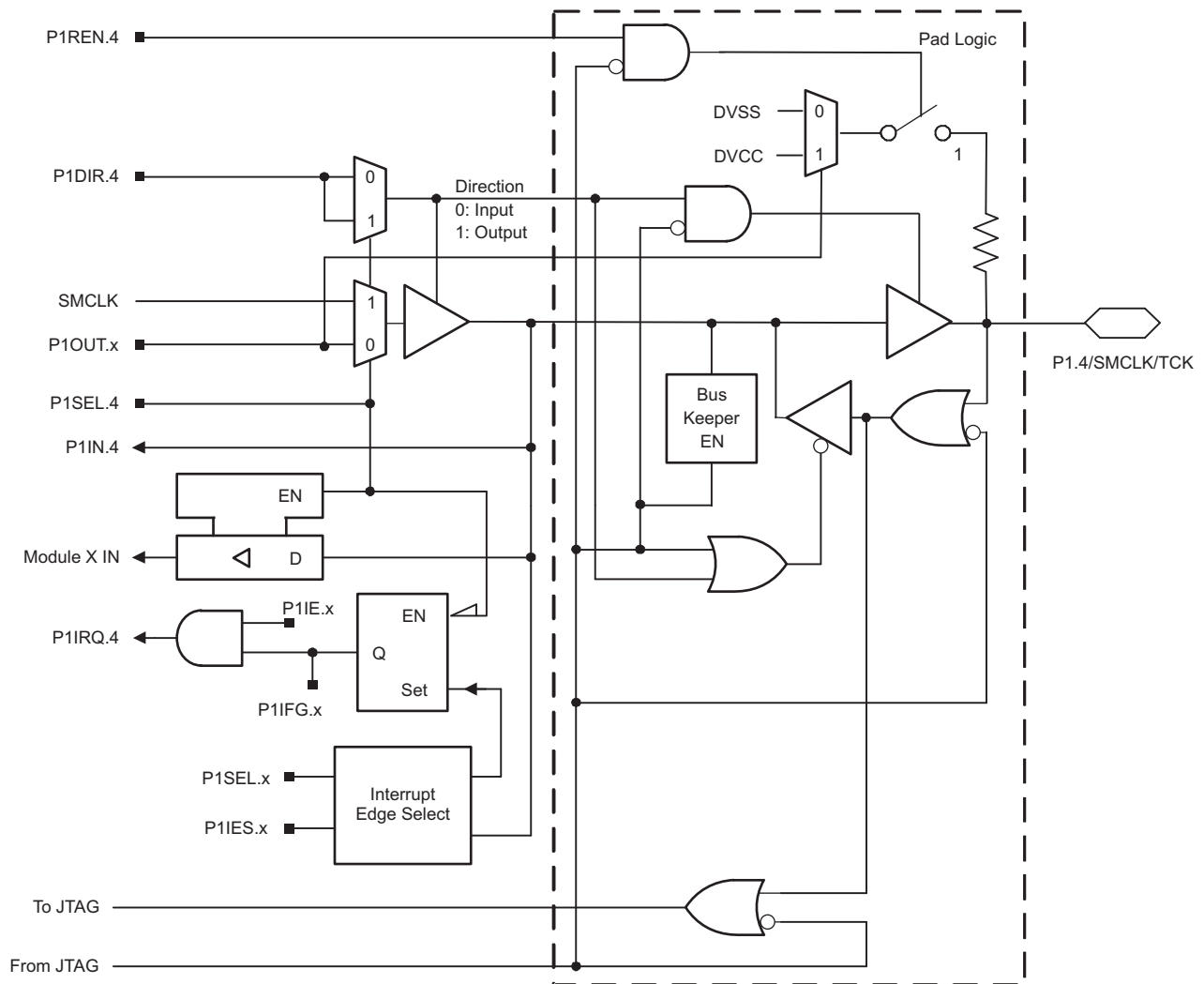

Table 18. Port P1 (P1.4) Pin Functions

| PIN NAME (P1.x) | x | FUNCTION | CONTROL BITS AND SIGNALS ⁽¹⁾ | | |
|-----------------|---|--------------------|---|-----------------------|-----------|
| | | | P1DIR.x | P1SEL.x P1SEL2.x=0 | JTAG Mode |
| P1.4/SMCLK/TCK | 4 | P1.4 (I/O) | I: 0; O: 1 | 0 | 0 |
| | | SMCLK | 1 | 1 | 0 |
| | | TCK ⁽²⁾ | X | X | 1 |

(1) X = Don't care

(2) In JTAG mode, the internal pullup or pulldown resistors are disabled.

6.4 Port P1 Pin Schematic: P1.5 to P1.7

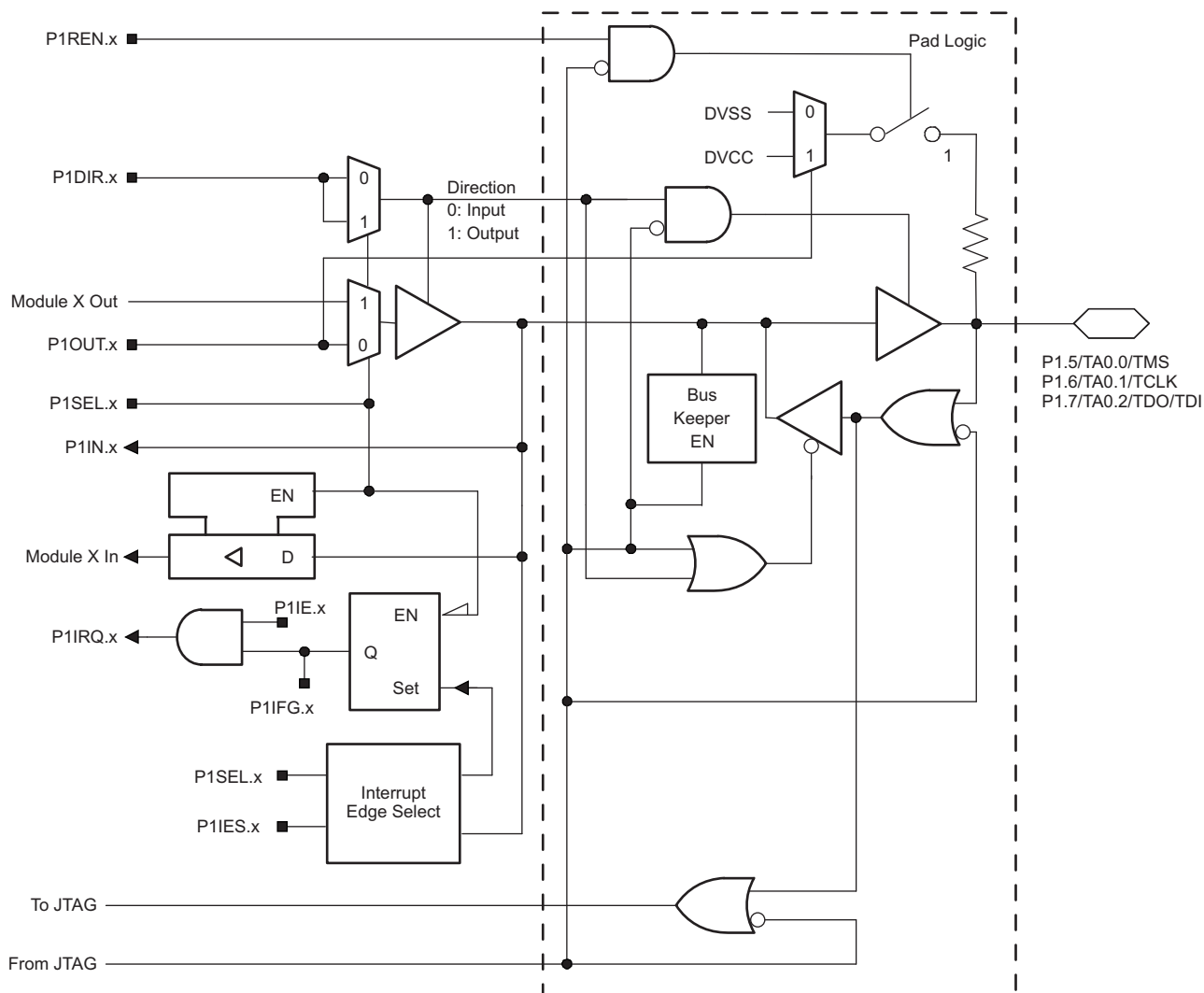

Table 19. Port P1 (P1.5 to P1.7) Pin Functions

| PIN NAME (P1.x) | x | FUNCTION | CONTROL BITS AND SIGNALS ⁽¹⁾ | | |
|---------------------|---|-------------------------|---|-----------------------|-----------|
| | | | P1DIR.x | P1SEL.x P1SEL2.x=0 | JTAG Mode |
| P1.5/TA0.0/TMS | 5 | P1.5 (I/O) | I: 0; O: 1 | 0 | 0 |
| | | Timer0_A3.TA0 | 1 | 1 | 0 |
| | | TMS ⁽²⁾ | X | X | 1 |
| P1.6/TA0.1/TDI/TCLK | 6 | P1.6 (I/O) | I: 0; O: 1 | 0 | 0 |
| | | Timer0_A3.TA1 | 1 | 1 | 0 |
| | | TDI/TCLK ⁽²⁾ | X | X | 1 |
| P1.7/TA0.2/TDO/TDI | 7 | P1.6 (I/O) | I: 0; O: 1 | 0 | 0 |
| | | Timer0_A3.TA2 | 1 | 1 | 0 |
| | | TDO/TDI ⁽²⁾ | X | X | 1 |

(1) X = Don't care

(2) In JTAG mode, the internal pullup or pulldown resistors are disabled.

6.5 Port P2 Pin Schematic: P2.0 and P2.1, Input/Output With Schmitt Trigger

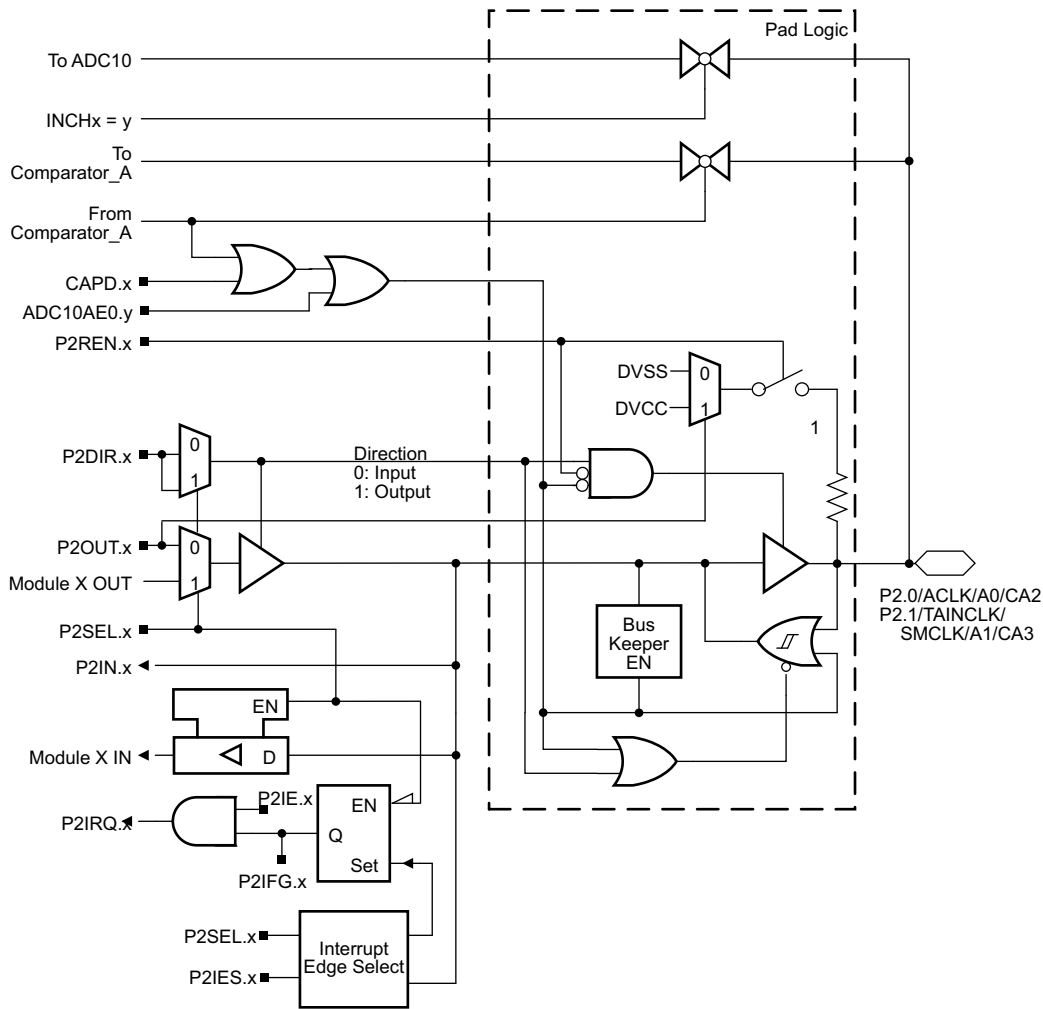

Table 20. Port P2 (P2.0 and P2.1) Pin Functions

| PIN NAME (P2.x) | x | FUNCTION | CONTROL BITS AND SIGNALS ⁽¹⁾ | | | |
|-------------------------------|---|--------------------------------------|---|--------|------------|-------------------------|
| | | | ADC10AE0.y | CAPD.x | P2DIR.x | P2SEL.x P2SEL2.x = 0 |
| P2.0/ACLK/A0/CA2 | 0 | P2.0 (I/O) | 0 | 0 | I: 0; O: 1 | 0 |
| | | ACLK | 0 | 0 | 1 | 1 |
| | | A0 | 1 | 0 | X | X |
| | | CA2 | 0 | 1 | X | X |
| P2.1/TAINCLK/ SMCLK/A1/CA3 | 1 | P2.1 (I/O) | 0 | 0 | I: 0; O: 1 | 0 |
| | | Timer0_A3.TAINCLK, Timer1_A2.TAINCLK | 0 | 0 | 0 | 1 |
| | | SMCLK | 0 | 0 | 1 | 1 |
| | | A1 | 1 | 0 | X | X |
| CA3 | 0 | 1 | X | X | | |

(1) X = Don't care

6.6 Port P2 Pin Schematic: P2.2, Input/Output With Schmitt Trigger

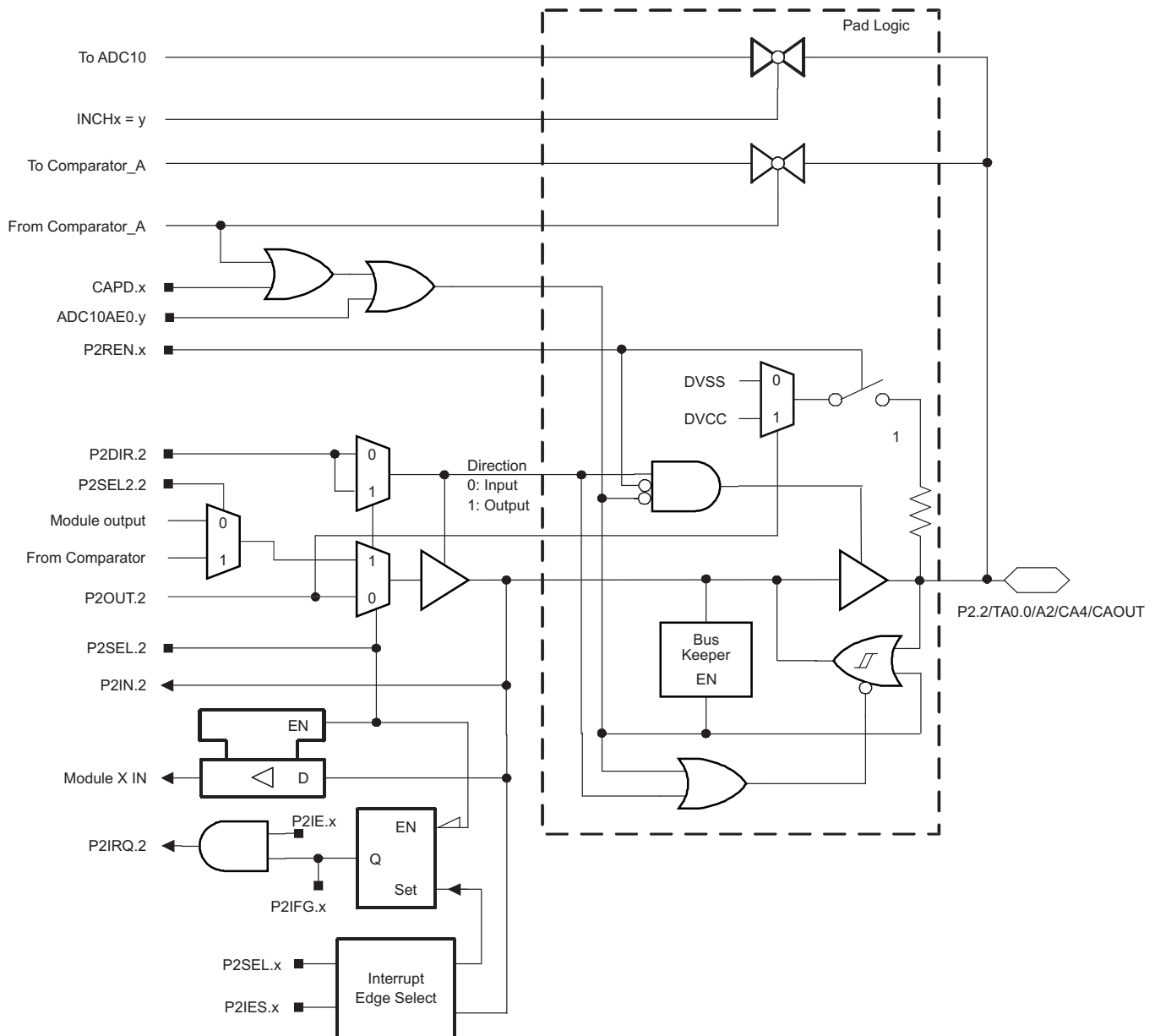

Table 21. Port P2 (P2.2) Pin Functions

| PIN NAME (P2.x) | x | FUNCTION | CONTROL BITS AND SIGNALS ⁽¹⁾ | | | | |
|-------------------------|---|-----------------|---|--------|------------|---------|----------|
| | | | ADC10AE0.x | CAPD.x | P2DIR.x | P2SEL.x | P2SEL2.x |
| P2.2/TA0.0/A2/CA4/CAOUT | 2 | P2.0 (I/O) | 0 | 0 | I: 0; O: 1 | 0 | 0 |
| | | Timer0_A3.TA0 | 0 | 0 | 1 | 1 | 0 |
| | | Timer0_A3.CCI0B | 0 | 0 | 0 | 1 | 0 |
| | | A2 | 1 | 0 | X | X | X |
| | | CA4 | 0 | 1 | X | X | X |
| | | CAOUT | 0 | 0 | 1 | 1 | 1 |

(1) X = Don't care

6.7 Port P2 Pin Schematic: P2.3 and P2.4, Input/Output With Schmitt Trigger

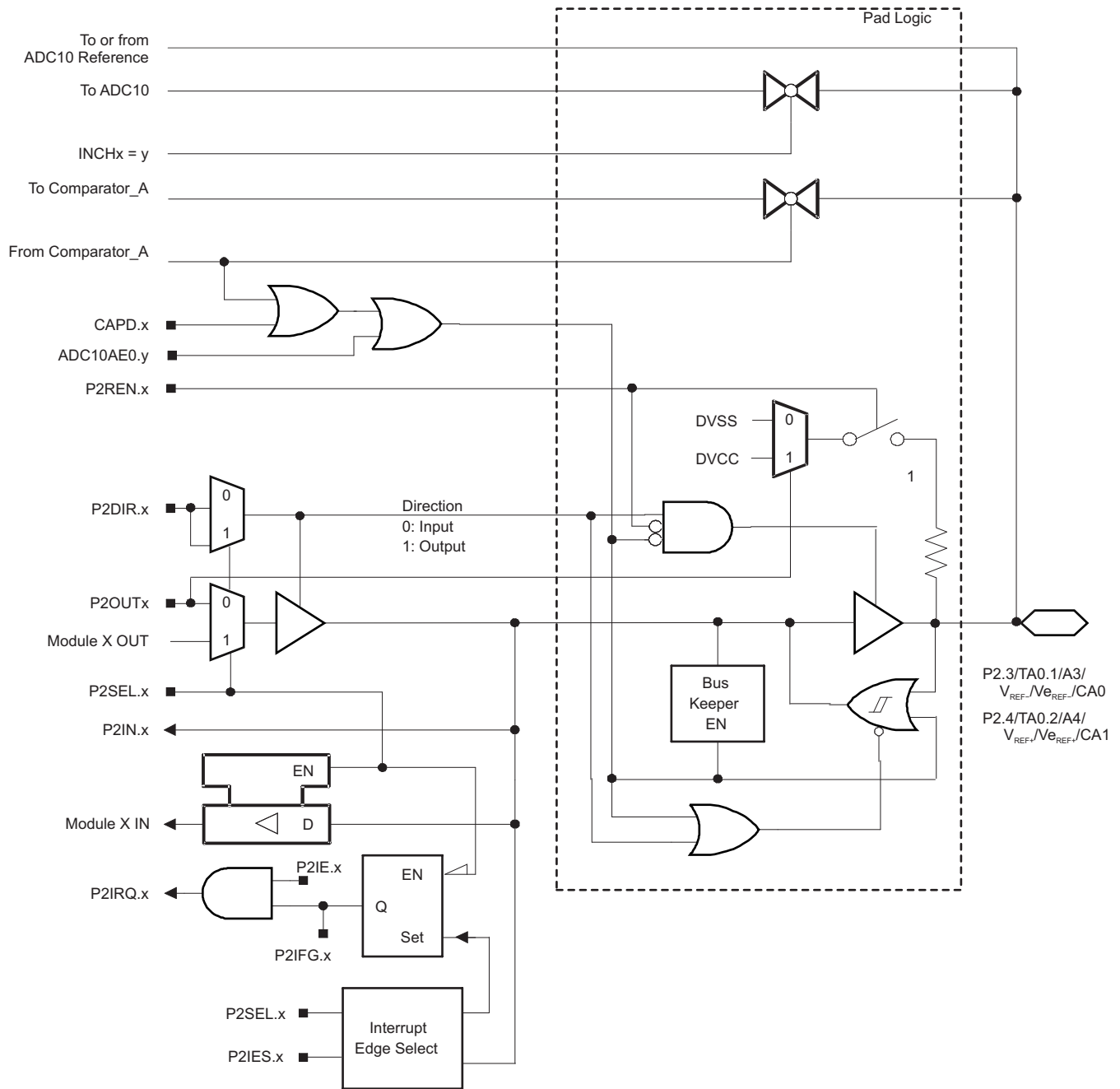

Table 22. Port P2 (P2.3 and P2.4) Pin Functions

| PIN NAME (P2.x) | x | FUNCTION | CONTROL BITS AND SIGNALS ⁽¹⁾ | | | |
|--|---|--|---|--------|------------|-------------------------|
| | | | ADC10AE0.y | CAPD.x | P2DIR.x | P2SEL.x P2SEL2.x = 0 |
| P2.3/TA0.1/A3/ V _{REF-} /V _{eREF-} / CA0 | 3 | P2.3 (I/O) | 0 | 0 | I: 0; O: 1 | 0 |
| | | Timer0_A3.TA1 | 0 | 0 | 1 | 1 |
| | | A3/V _{REF-} /V _{eREF-} | 1 | 0 | X | X |
| | | CA0 | 0 | 1 | X | X |

(1) X = Don't care

Port P2 Pin Schematic: P2.3 and P2.4, Input/Output With Schmitt Trigger (continued)
Table 22. Port P2 (P2.3 and P2.4) Pin Functions (continued)

| PIN NAME (P2.x) | x | FUNCTION | CONTROL BITS AND SIGNALS ⁽¹⁾ | | | |
|---|---|---|---|--------|------------|-------------------------|
| | | | ADC10AE0.y | CAPD.x | P2DIR.x | P2SEL.x P2SEL2.x = 0 |
| P2.4/TA0.2/A4/ V _{REF+} /V _{REF-} /CA1 | 4 | P2.4 (I/O) | 0 | 0 | I: 0; O: 1 | 0 |
| | | Timer0_A3.TA2 | 0 | 0 | 1 | 1 |
| | | A4/V _{REF+} /V _{REF-} | 1 | 0 | X | X |
| | | CA1 | 0 | 1 | X | X |

6.8 Port P2 Pin Schematic: P2.5, Input/Output With Schmitt Trigger

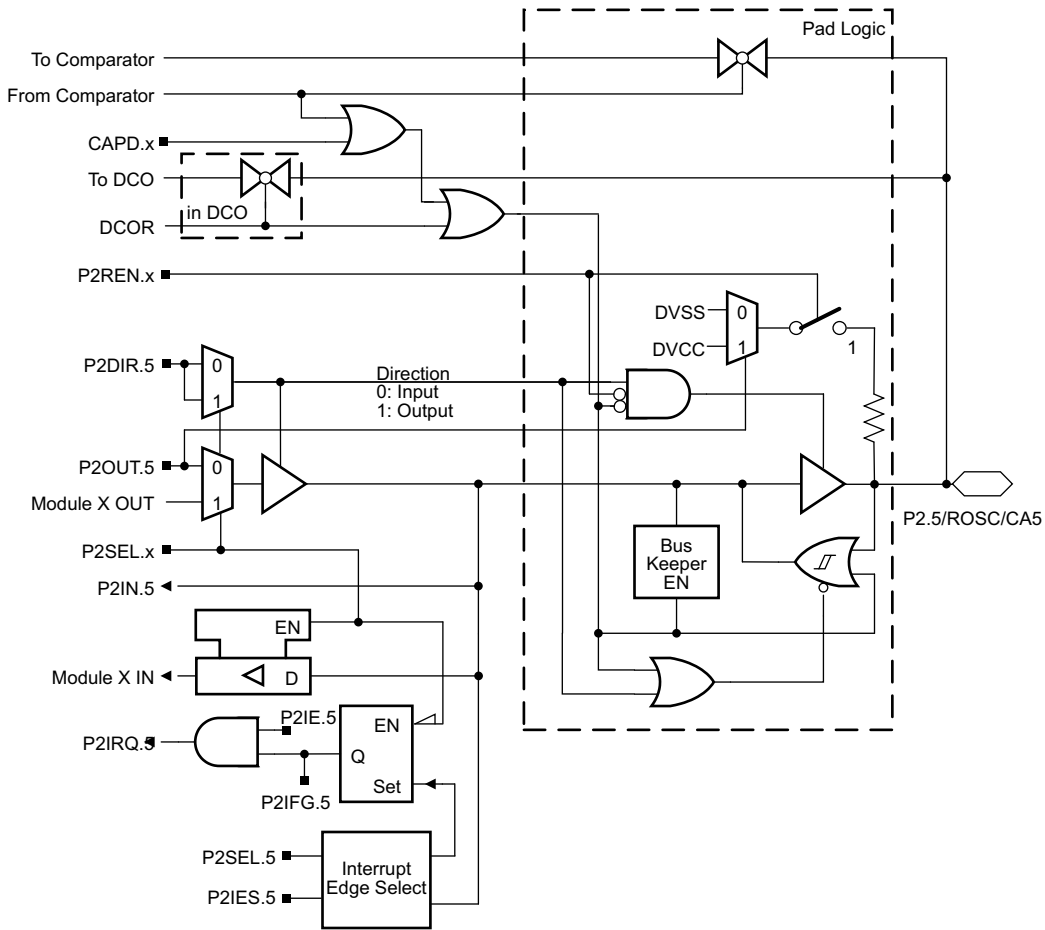

Table 23. Port P2 (P2.5) Pin Functions

| PIN NAME (P2.x) | x | FUNCTION | CONTROL BITS AND SIGNALS ⁽¹⁾ | | | |
|----------------------------|---|--------------------|---|------|------------|-------------------------|
| | | | CAPD.5 | DCOR | P2DIR.5 | P2SEL.5 P2SEL2.x = 0 |
| P2.5/R _{osc} /CA5 | 5 | P2.5 (I/O) | 0 | 0 | I: 0, O: 1 | 0 |
| | | R _{osc} | 0 | 1 | X | X |
| | | DVSS | 0 | 0 | 1 | 1 |
| | | CA5 ⁽²⁾ | 1 | 0 | X | X |

(1) X = Don't care

(2) Setting the CAPD.x bit disables the output driver as well as the input to prevent parasitic cross currents when applying analog signals. Selecting the CAx input to the comparator multiplexer with the P2CAx bits automatically disables the input buffer for that pin, regardless of the state of the associated CAPD.x bit.

6.9 Port P2 Pin Schematic: P2.6, Input/Output With Schmitt Trigger

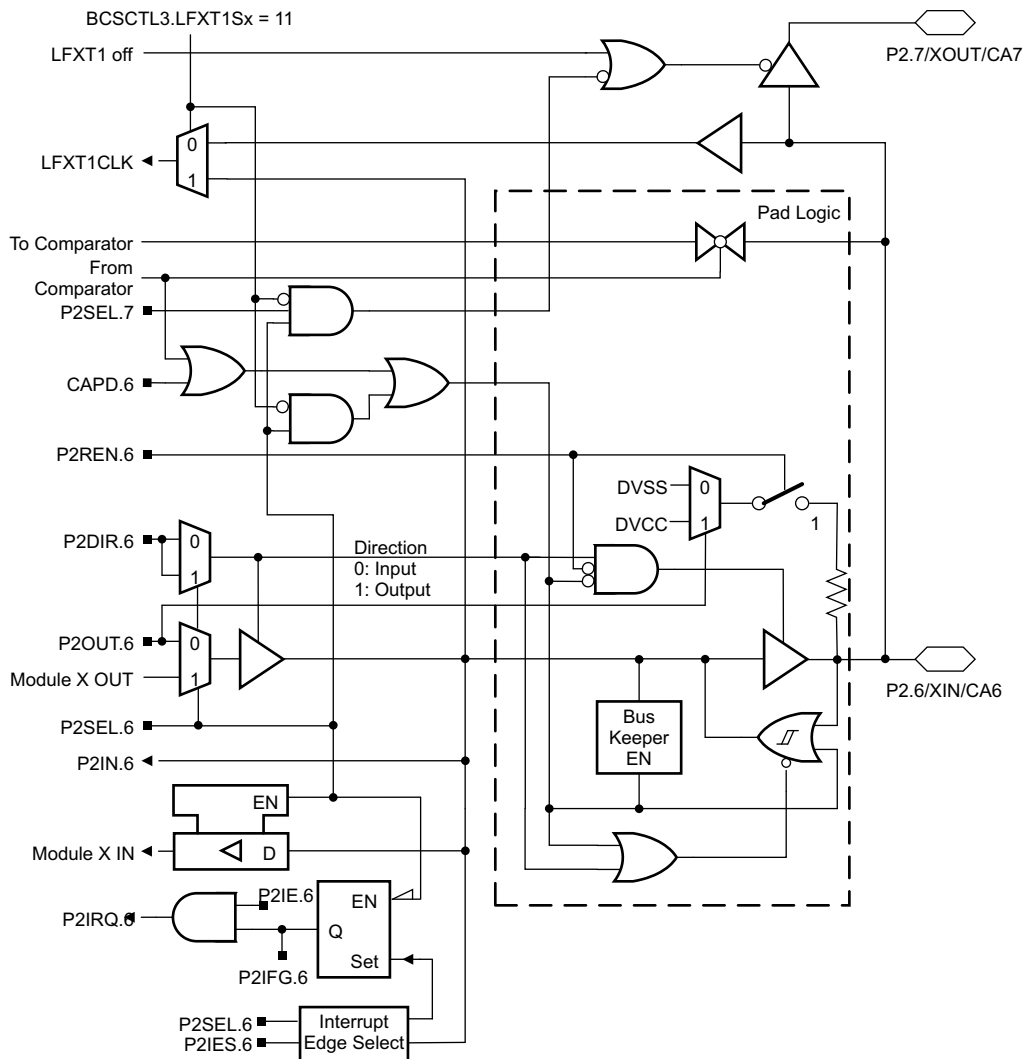

Table 24. Port P2 (P2.6) Pin Functions

| PIN NAME (P2.x) | x | FUNCTION | CONTROL BITS AND SIGNALS ⁽¹⁾ | | |
|-----------------|---|--------------------|---|------------|-------------------------|
| | | | CAPD.6 | P2DIR.6 | P2SEL.6 P2SEL2.x = 0 |
| P2.6/XIN/CA6 | 6 | P2.6 (I/O) | 0 | I: 0; O: 1 | 0 |
| | | XIN (default) | X | 1 | 1 |
| | | CA6 ⁽²⁾ | 1 | X | 0 |

(1) X = Don't care

(2) Setting the CAPD.x bit disables the output driver as well as the input to prevent parasitic cross currents when applying analog signals. Selecting the CAx input to the comparator multiplexer with the P2CAx bits automatically disables the input buffer for that pin, regardless of the state of the associated CAPD.x bit.

6.10 Port P2 Pin Schematic: P2.7, Input/Output With Schmitt Trigger

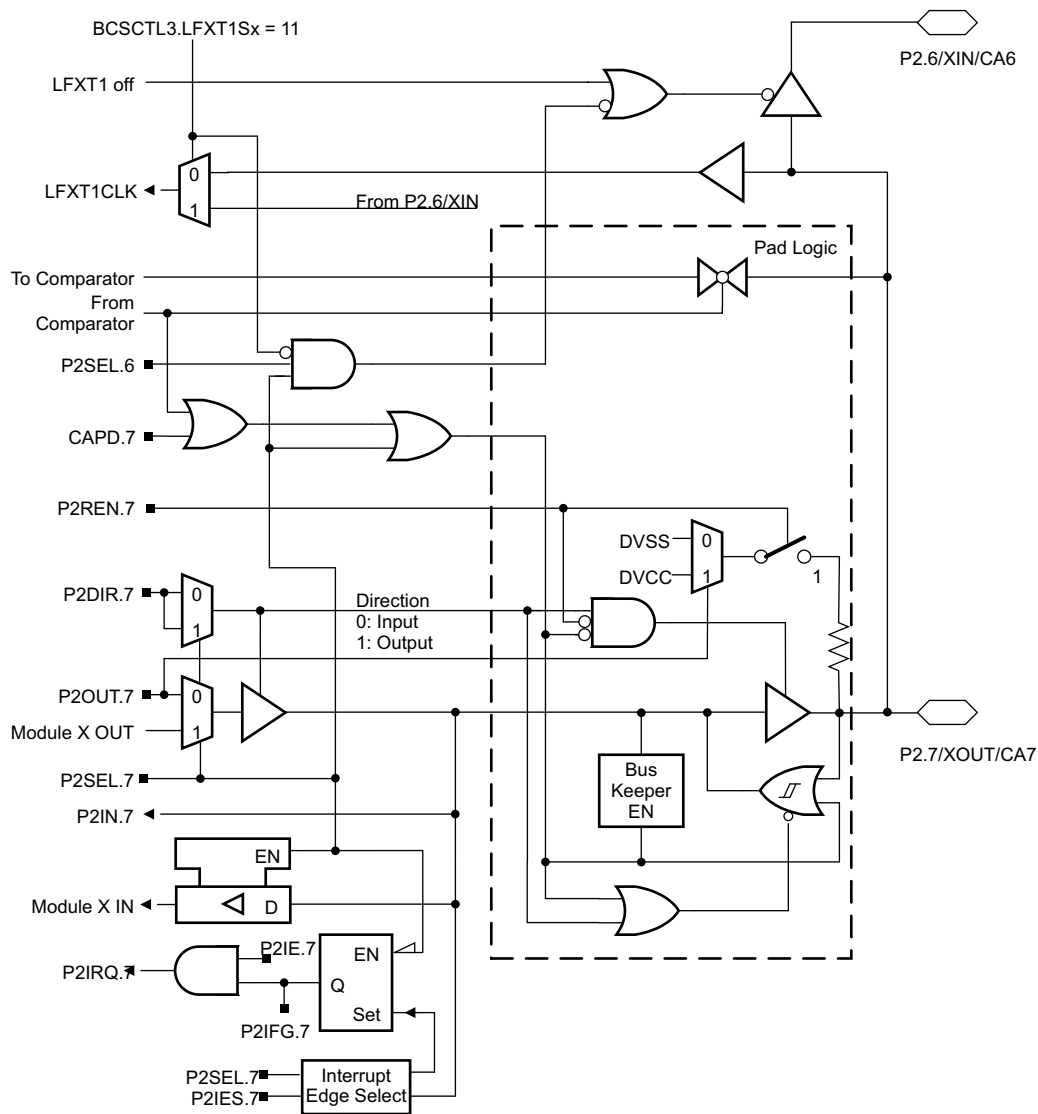

Table 25. Port P2 (P2.7) Pin Functions

| PIN NAME (P2.x) | x | FUNCTION | CONTROL BITS AND SIGNALS ⁽¹⁾ | | |
|-----------------|---|--------------------|---|------------|-------------------------|
| | | | CAPD.7 | P2DIR.7 | P2SEL.7 P2SEL2.x = 0 |
| P2.7/XOUT/CA7 | 7 | P2.7 (I/O) | 0 | I: 0, O: 1 | 0 |
| | | XOUT (default) | X | 1 | 1 |
| | | CA7 ⁽²⁾ | 1 | X | 0 |

- (1) X = Don't care
- (2) Setting the CAPD.x bit disables the output driver as well as the input to prevent parasitic cross currents when applying analog signals. Selecting the CAx input to the comparator multiplexer with the P2CAx bits automatically disables the input buffer for that pin, regardless of the state of the associated CAPD.x bit.

6.11 Port P3 Pin Schematic: P3.0, Input/Output With Schmitt Trigger

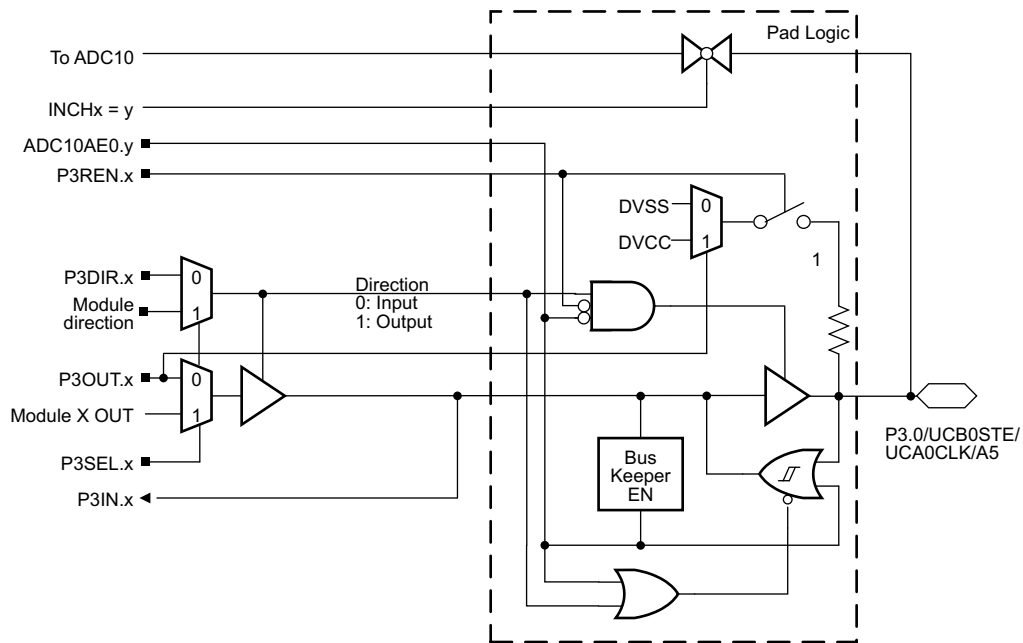

Table 26. Port P3 (P3.0) Pin Functions

| PIN NAME (P3.x) | x | FUNCTION | CONTROL BITS AND SIGNALS ⁽¹⁾ | | |
|-----------------------------|---|--------------------------------|---|------------|-------------------------|
| | | | ADC10AE0.y | P3DIR.x | P3SEL.x P3SEL2.x = 0 |
| P3.0/UCB0STE/ UCA0CLK/A5 | 0 | P3.0 (I/O) | 0 | I: 0; O: 1 | 0 |
| | | UCB0STE/UCA0CLK ⁽²⁾ | 0 | X | 1 |
| | | A5 ⁽²⁾ | 1 | X | X |

(1) X = Don't care

(2) The pin direction is controlled by the USCI module.

6.12 Port P3 Pin Schematic: P3.1 to P3.5, Input/Output With Schmitt Trigger

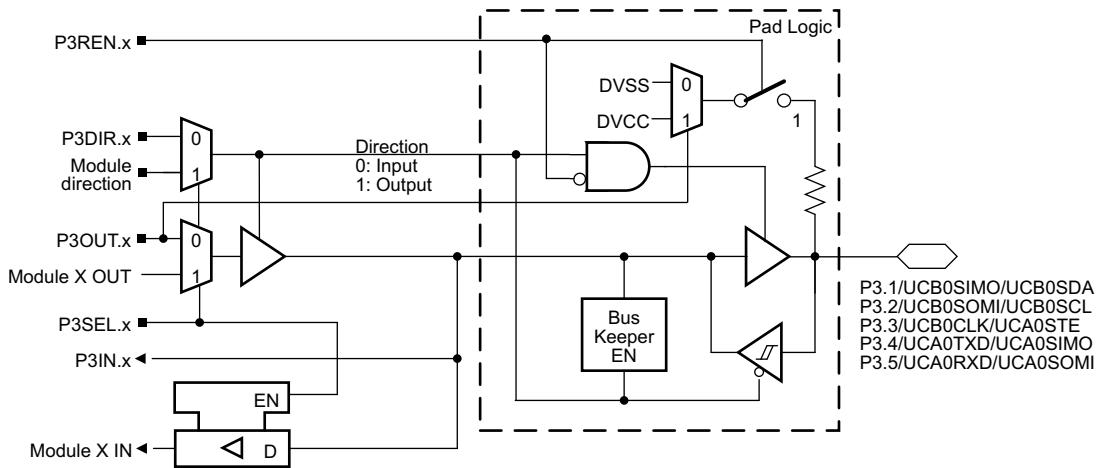

Table 27. Port P3 (P3.1 to P3.5) Pin Functions

| PIN NAME (P3.x) | x | FUNCTION | CONTROL BITS AND SIGNALS ⁽¹⁾ | |
|---------------------------|---|------------------------------------|---|---------|
| | | | P3DIR.x | P3SEL.x |
| P3.1/UCB0SIMO/ UCB0SDA | 1 | P3.1 (I/O) | I: 0; O: 1 | 0 |
| | | UCB0SIMO/UCB0SDA ⁽²⁾⁽³⁾ | X | 1 |
| P3.2/UCB0SOMI/ UCB0SCL | 2 | P3.2 (I/O) | I: 0; O: 1 | 0 |
| | | UCB0SOMI/UCB0SCL ⁽²⁾⁽³⁾ | X | 1 |
| P3.3/UCB0CLK/ UCA0STE | 3 | P3.3 (I/O) | I: 0; O: 1 | 0 |
| | | UCB0CLK/UCA0STE ⁽²⁾ | X | 1 |
| P3.4/UCA0TXD/ UCA0SIMO | 4 | P3.4 (I/O) | I: 0; O: 1 | 0 |
| | | UCA0TXD/UCA0SIMO ⁽²⁾ | X | 1 |
| P3.5/UCA0RXD/ UCA0SOMI | 5 | P3.5 (I/O) | I: 0; O: 1 | 0 |
| | | UCA0RXD/UCA0SOMI ⁽²⁾ | X | 1 |

- (1) X = Don't care
- (2) The pin direction is controlled by the USC1 module.
- (3) If the I2C functionality is selected, the output drives only the logical 0 to V_{SS} level.

6.13 Port P3 Pin Schematic: P3.6 and P3.7, Input/Output With Schmitt Trigger

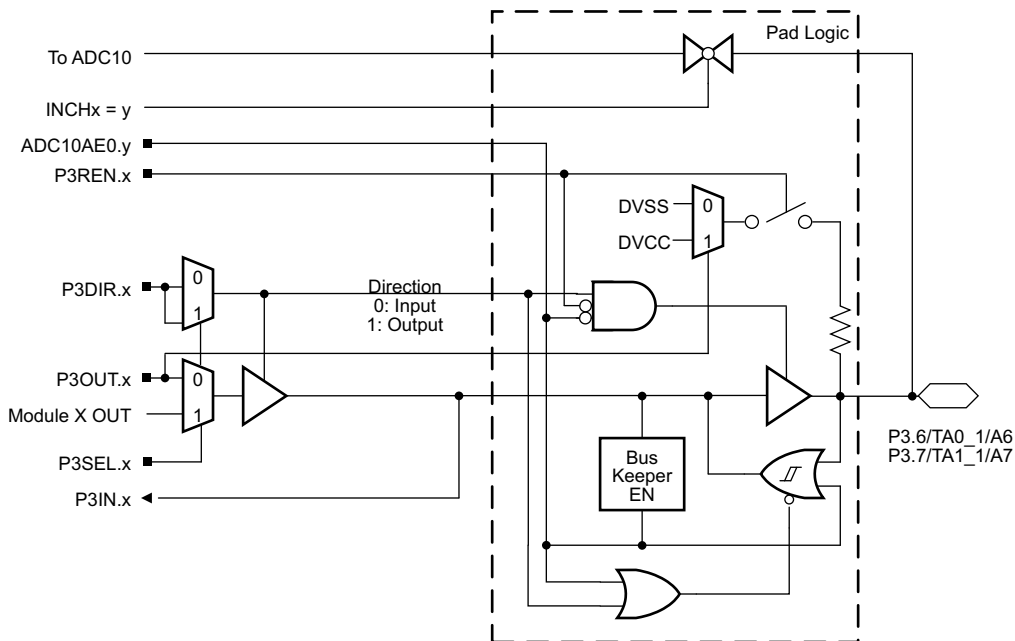

Table 28. Port P3 (P3.6 and P3.7) Pin Functions

| PIN NAME (P3.x) | x | FUNCTION | CONTROL BITS AND SIGNALS ⁽¹⁾ | | |
|-----------------|---|-----------------|---|------------|---------|
| | | | ADC10AE0.y | P3DIR.x | P3SEL.x |
| P3.6/TA1.0/A6 | 6 | P3.6 (I/O) | 0 | I: 0; O: 1 | 0 |
| | | Timer1_A2.TA0 | 0 | 1 | 1 |
| | | Timer1_A2.CCI0B | 0 | 0 | 1 |
| | | A6 | 1 | X | X |
| P3.7/TA1.1/A7 | 7 | P3.7 (I/O) | 0 | I: 0; O: 1 | 0 |
| | | Timer1_A2.TA1 | 0 | 1 | 1 |
| | | Timer1_A2.CCI1A | 0 | 0 | 1 |
| | | A7 | 1 | X | X |

(1) X = Don't care

6.14 JTAG Fuse Check Mode

Devices that have the fuse on the TEST terminal have a fuse check mode that tests the continuity of the fuse the first time the JTAG port is accessed after a power-on reset (POR). When activated, a fuse check current, I_{TF} , of 1 mA at 3 V, 2.5 mA at 5 V can flow from the TEST pin to ground if the fuse is not burned. Care must be taken to avoid accidentally activating the fuse check mode and increasing overall system power consumption.

When the TEST pin is again taken low after a test or programming session, the fuse check mode and sense currents are terminated.

Activation of the fuse check mode occurs with the first negative edge on the TMS pin after power up or if TMS is being held low during power up. The second positive edge on the TMS pin deactivates the fuse check mode. After deactivation, the fuse check mode remains inactive until another POR occurs. After each POR the fuse check mode has the potential to be activated.

The fuse check current flows only when the fuse check mode is active and the TMS pin is in a low state (see [Figure 32](#)). Therefore, the additional current flow can be prevented by holding the TMS pin high (default condition).

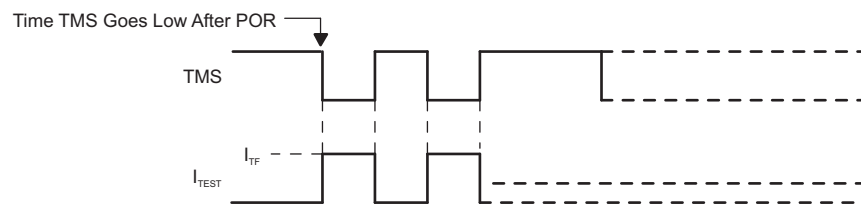

Figure 32. Fuse Check Mode Current

NOTE

The CODE and RAM data protection is ensured if the JTAG fuse is blown and the 256-bit bootloader access key is used. Also, see the [Bootstrap Loader](#) section for more information.

7 Device and Documentation Support

7.1 Receiving Notification of Documentation Updates

To receive notification of documentation updates, navigate to the device product folder on ti.com. In the upper right corner, click on *Alert me* to register and receive a weekly digest of any product information that has changed. For change details, review the revision history included in any revised document.

7.2 Community Resources

The following links connect to TI community resources. Linked contents are provided "AS IS" by the respective contributors. They do not constitute TI specifications and do not necessarily reflect TI's views; see TI's [Terms of Use](#).

TI E2E™ Online Community *TI's Engineer-to-Engineer (E2E) Community*. Created to foster collaboration among engineers. At e2e.ti.com, you can ask questions, share knowledge, explore ideas and help solve problems with fellow engineers.

Design Support *TI's Design Support* Quickly find helpful E2E forums along with design support tools and contact information for technical support.

7.3 Trademarks

E2E is a trademark of Texas Instruments.
All other trademarks are the property of their respective owners.

7.4 Electrostatic Discharge Caution



This integrated circuit can be damaged by ESD. Texas Instruments recommends that all integrated circuits be handled with appropriate precautions. Failure to observe proper handling and installation procedures can cause damage.

ESD damage can range from subtle performance degradation to complete device failure. Precision integrated circuits may be more susceptible to damage because very small parametric changes could cause the device not to meet its published specifications.

7.5 Glossary

[SLYZ022](#) — *TI Glossary*.

This glossary lists and explains terms, acronyms, and definitions.

8 Mechanical, Packaging, and Orderable Information

The following pages include mechanical, packaging, and orderable information. This information is the most current data available for the designated devices. This data is subject to change without notice and revision of this document. For browser-based versions of this data sheet, refer to the left-hand navigation.

PACKAGING INFORMATION

| Orderable Device | Status (1) | Package Type | Package Drawing | Pins | Package Qty | Eco Plan (2) | Lead/Ball Finish (6) | MSL Peak Temp (3) | Op Temp (°C) | Device Marking (4/5) | Samples |
|--------------------|---------------|--------------|-----------------|------|-------------|-------------------------|-------------------------|----------------------|--------------|-------------------------|-------------------------|
| MSP430F2132QRHBREP | ACTIVE | VQFN | RHB | 32 | 3000 | Green (RoHS & no Sb/Br) | CU NIPDAU | Level-2-260C-1 YEAR | -40 to 125 | F2132Q RHBEP | Samples |
| MSP430F2132QRHBTEP | ACTIVE | VQFN | RHB | 32 | 250 | Green (RoHS & no Sb/Br) | CU NIPDAU | Level-2-260C-1 YEAR | -40 to 125 | F2132Q RHBEP | Samples |
| V62/13624-01XE | ACTIVE | VQFN | RHB | 32 | 250 | Green (RoHS & no Sb/Br) | CU NIPDAU | Level-2-260C-1 YEAR | -40 to 125 | F2132Q RHBEP | Samples |
| V62/13624-01XE-R | ACTIVE | VQFN | RHB | 32 | 3000 | Green (RoHS & no Sb/Br) | CU NIPDAU | Level-2-260C-1 YEAR | -40 to 125 | F2132Q RHBEP | Samples |

(1) The marketing status values are defined as follows:

ACTIVE: Product device recommended for new designs.

LIFEBUY: TI has announced that the device will be discontinued, and a lifetime-buy period is in effect.

NRND: Not recommended for new designs. Device is in production to support existing customers, but TI does not recommend using this part in a new design.

PREVIEW: Device has been announced but is not in production. Samples may or may not be available.

OBSOLETE: TI has discontinued the production of the device.

(2) **RoHS:** TI defines "RoHS" to mean semiconductor products that are compliant with the current EU RoHS requirements for all 10 RoHS substances, including the requirement that RoHS substance do not exceed 0.1% by weight in homogeneous materials. Where designed to be soldered at high temperatures, "RoHS" products are suitable for use in specified lead-free processes. TI may reference these types of products as "Pb-Free".

RoHS Exempt: TI defines "RoHS Exempt" to mean products that contain lead but are compliant with EU RoHS pursuant to a specific EU RoHS exemption.

Green: TI defines "Green" to mean the content of Chlorine (Cl) and Bromine (Br) based flame retardants meet JS709B low halogen requirements of <=1000ppm threshold. Antimony trioxide based flame retardants must also meet the <=1000ppm threshold requirement.

(3) MSL, Peak Temp. - The Moisture Sensitivity Level rating according to the JEDEC industry standard classifications, and peak solder temperature.

(4) There may be additional marking, which relates to the logo, the lot trace code information, or the environmental category on the device.

(5) Multiple Device Markings will be inside parentheses. Only one Device Marking contained in parentheses and separated by a "-" will appear on a device. If a line is indented then it is a continuation of the previous line and the two combined represent the entire Device Marking for that device.

(6) Lead/Ball Finish - Orderable Devices may have multiple material finish options. Finish options are separated by a vertical ruled line. Lead/Ball Finish values may wrap to two lines if the finish value exceeds the maximum column width.

Important Information and Disclaimer:The information provided on this page represents TI's knowledge and belief as of the date that it is provided. TI bases its knowledge and belief on information provided by third parties, and makes no representation or warranty as to the accuracy of such information. Efforts are underway to better integrate information from third parties. TI has taken and

continues to take reasonable steps to provide representative and accurate information but may not have conducted destructive testing or chemical analysis on incoming materials and chemicals. TI and TI suppliers consider certain information to be proprietary, and thus CAS numbers and other limited information may not be available for release.

In no event shall TI's liability arising out of such information exceed the total purchase price of the TI part(s) at issue in this document sold by TI to Customer on an annual basis.

OTHER QUALIFIED VERSIONS OF MSP430F2132-EP :

- Catalog: [MSP430F2132](#)

NOTE: Qualified Version Definitions:

- Catalog - TI's standard catalog product

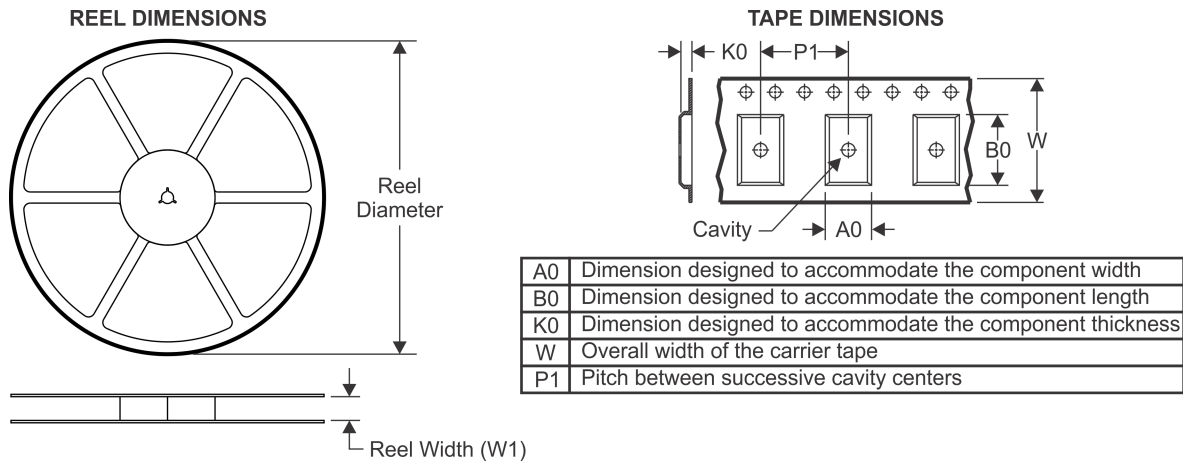
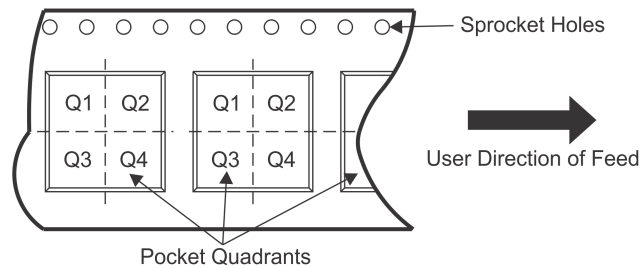
TAPE AND REEL INFORMATION

QUADRANT ASSIGNMENTS FOR PIN 1 ORIENTATION IN TAPE

*All dimensions are nominal

| Device | Package Type | Package Drawing | Pins | SPQ | Reel Diameter (mm) | Reel Width W1 (mm) | A0 (mm) | B0 (mm) | K0 (mm) | P1 (mm) | W (mm) | Pin1 Quadrant |
|--------------------|--------------|-----------------|------|------|--------------------|--------------------|---------|---------|---------|---------|--------|---------------|
| MSP430F2132QRHBREP | VQFN | RHB | 32 | 3000 | 330.0 | 12.4 | 5.3 | 5.3 | 1.5 | 8.0 | 12.0 | Q2 |
| MSP430F2132QRHBTEP | VQFN | RHB | 32 | 250 | 180.0 | 12.4 | 5.3 | 5.3 | 1.5 | 8.0 | 12.0 | Q2 |

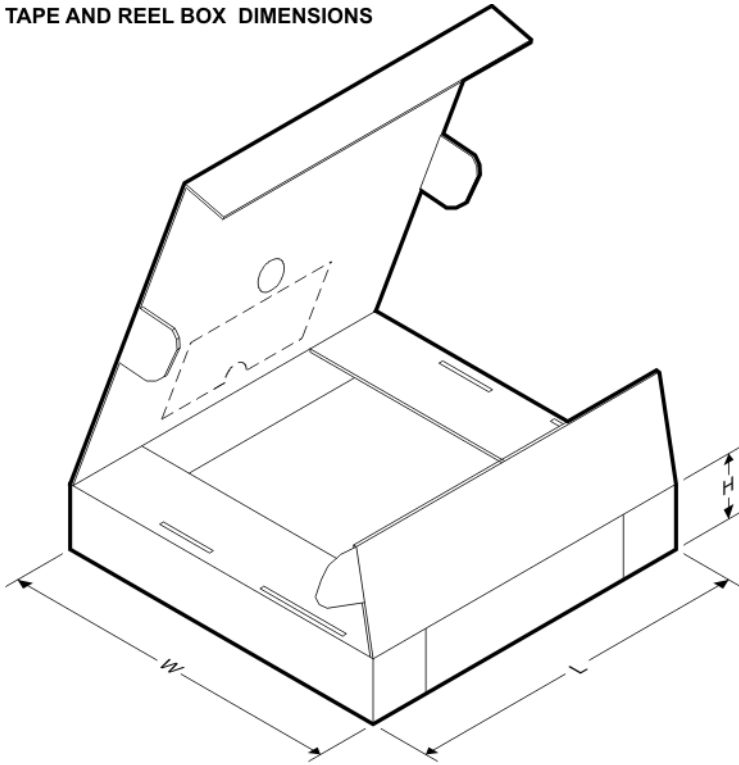
TAPE AND REEL BOX DIMENSIONS



*All dimensions are nominal

| Device | Package Type | Package Drawing | Pins | SPQ | Length (mm) | Width (mm) | Height (mm) |
|--------------------|--------------|-----------------|------|------|-------------|------------|-------------|
| MSP430F2132QRHBREP | VQFN | RHB | 32 | 3000 | 367.0 | 367.0 | 35.0 |
| MSP430F2132QRHBTEP | VQFN | RHB | 32 | 250 | 210.0 | 185.0 | 35.0 |

GENERIC PACKAGE VIEW

RHB 32

VQFN - 1 mm max height

5 x 5, 0.5 mm pitch

PLASTIC QUAD FLATPACK - NO LEAD

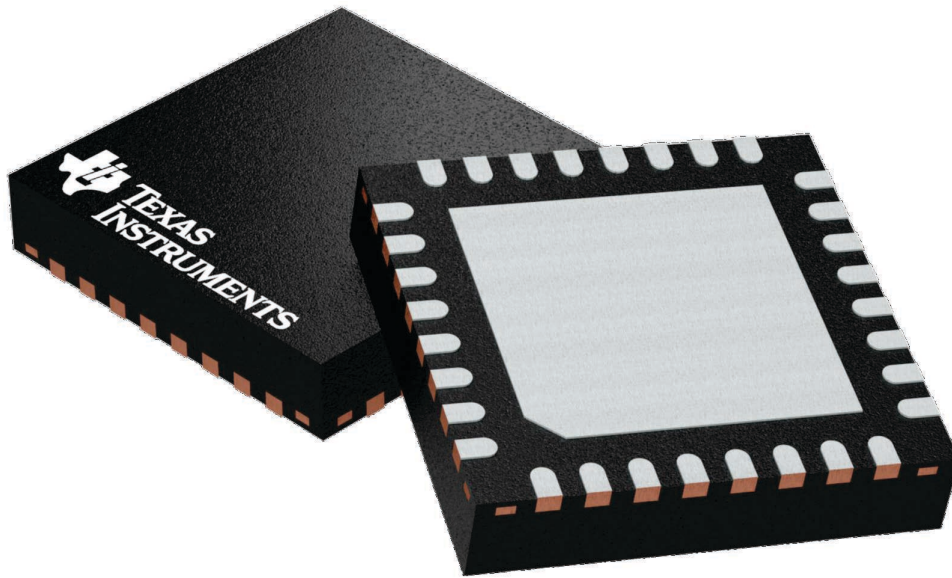

Images above are just a representation of the package family, actual package may vary.
Refer to the product data sheet for package details.

4224745/A

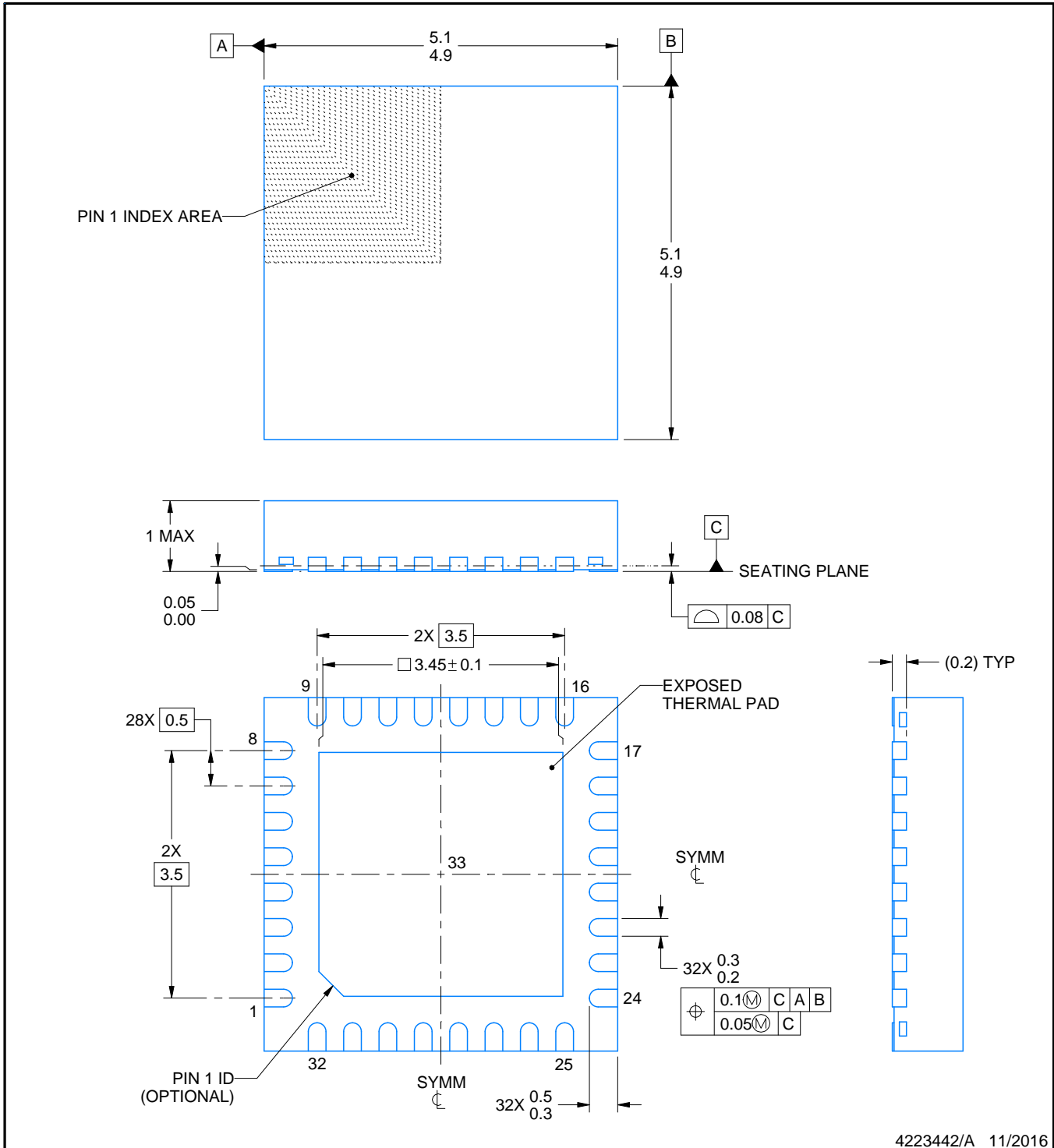
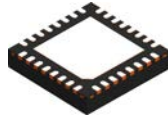

4223442/A 11/2016

NOTES:

1. All linear dimensions are in millimeters. Any dimensions in parenthesis are for reference only. Dimensioning and tolerancing per ASME Y14.5M.
2. This drawing is subject to change without notice.
3. The package thermal pad must be soldered to the printed circuit board for thermal and mechanical performance.

EXAMPLE BOARD LAYOUT

RHB0032E

VQFN - 1 mm max height

PLASTIC QUAD FLATPACK - NO LEAD

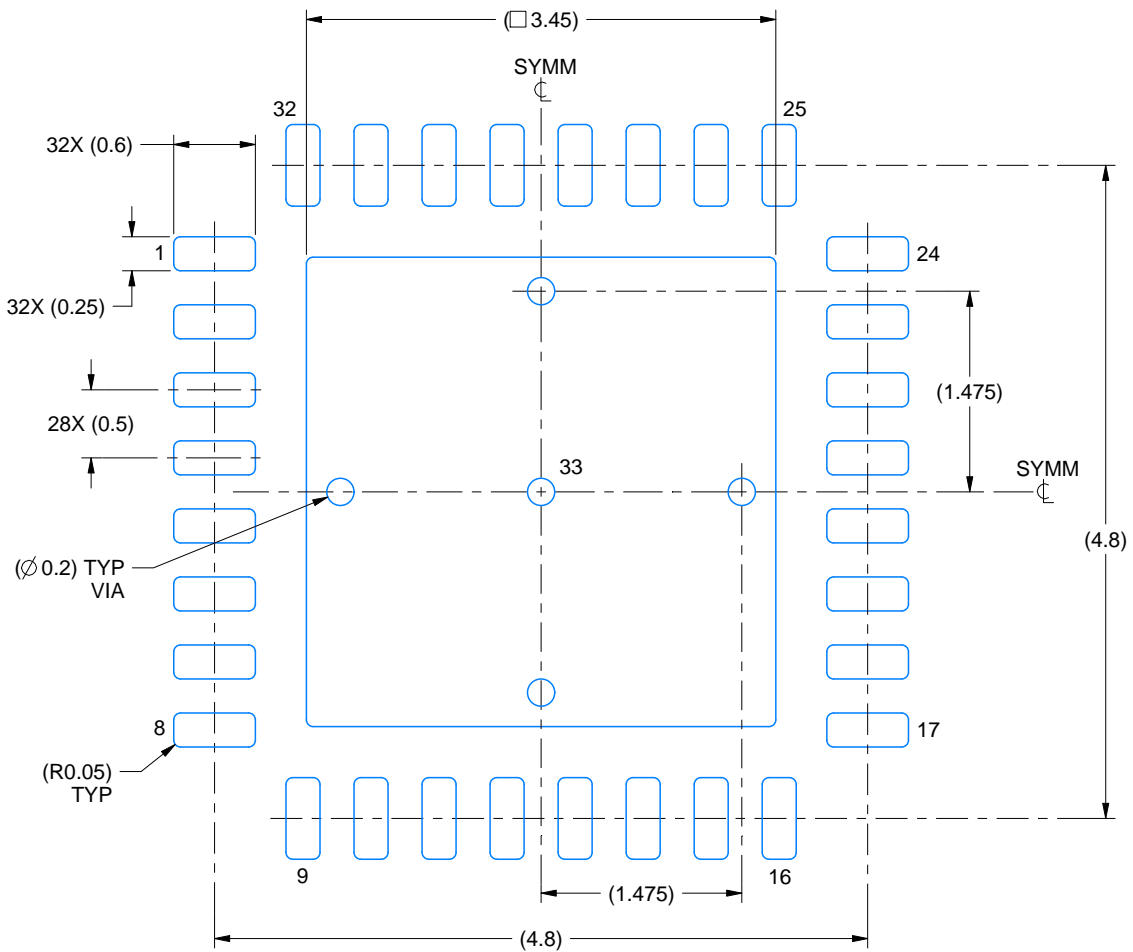

LAND PATTERN EXAMPLE
SCALE:18X

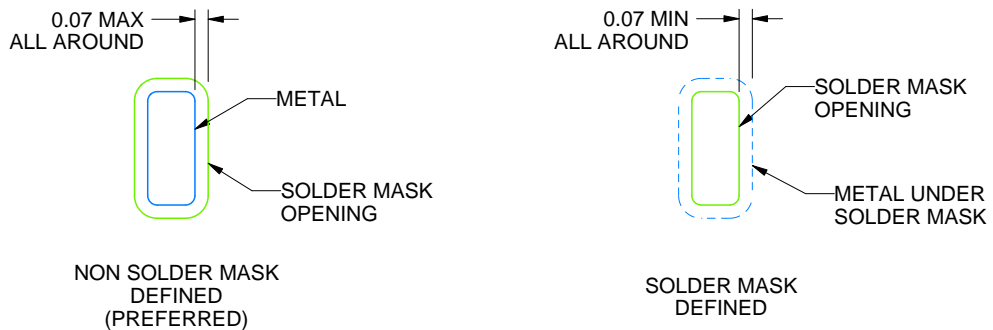

SOLDER MASK DETAILS

4223442/A 11/2016

NOTES: (continued)

- This package is designed to be soldered to a thermal pad on the board. For more information, see Texas Instruments literature number SLUA271 (www.ti.com/lit/slua271).
- Vias are optional depending on application, refer to device data sheet. If any vias are implemented, refer to their locations shown on this view. It is recommended that vias under paste be filled, plugged or tented.

EXAMPLE STENCIL DESIGN

RHB0032E

VQFN - 1 mm max height

PLASTIC QUAD FLATPACK - NO LEAD

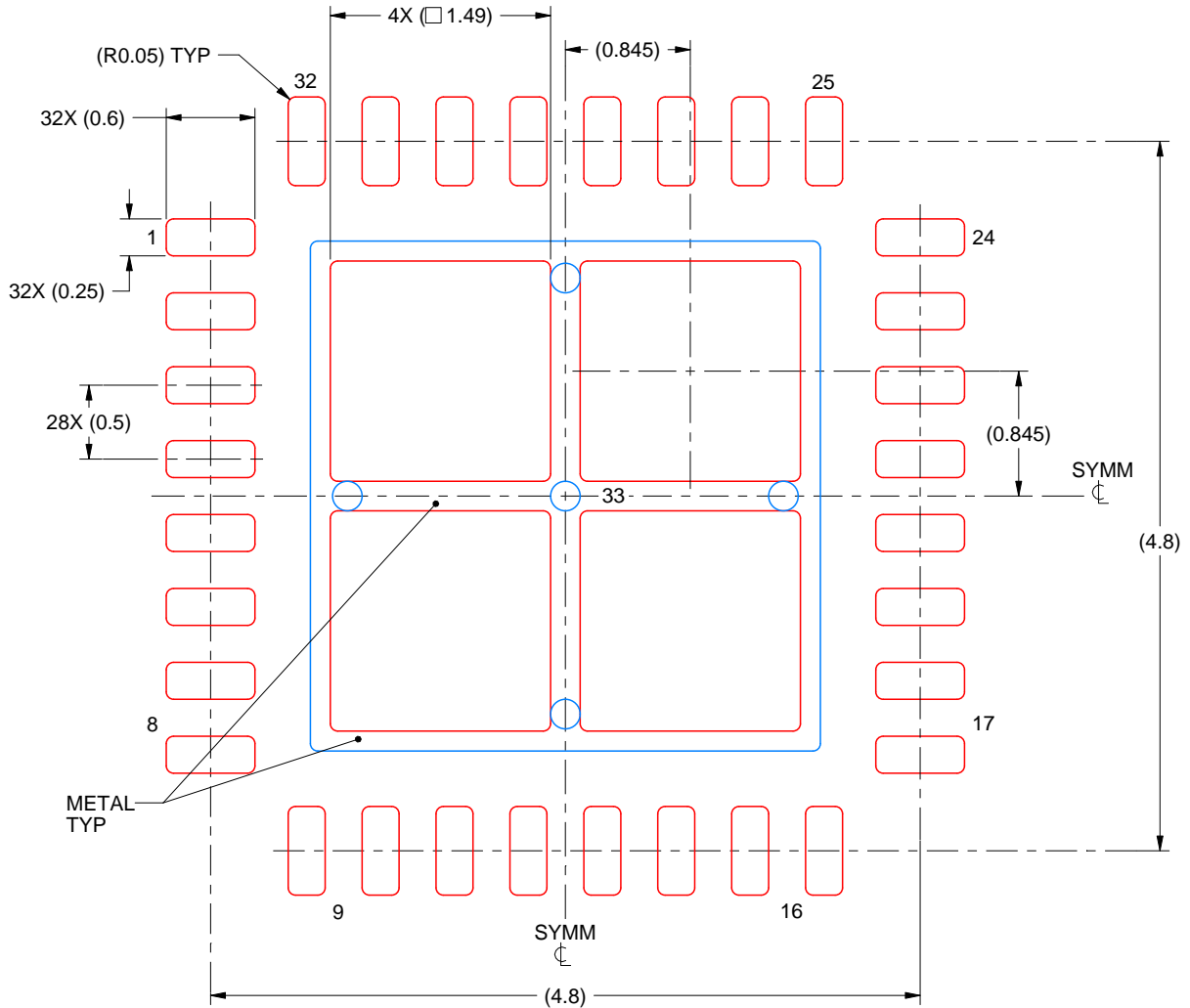

SOLDER PASTE EXAMPLE
BASED ON 0.125 mm THICK STENCIL

EXPOSED PAD 33:
75% PRINTED SOLDER COVERAGE BY AREA UNDER PACKAGE
SCALE:20X

4223442/A 11/2016

NOTES: (continued)

6. Laser cutting apertures with trapezoidal walls and rounded corners may offer better paste release. IPC-7525 may have alternate design recommendations.

IMPORTANT NOTICE AND DISCLAIMER

TI PROVIDES TECHNICAL AND RELIABILITY DATA (INCLUDING DATASHEETS), DESIGN RESOURCES (INCLUDING REFERENCE DESIGNS), APPLICATION OR OTHER DESIGN ADVICE, WEB TOOLS, SAFETY INFORMATION, AND OTHER RESOURCES "AS IS" AND WITH ALL FAULTS, AND DISCLAIMS ALL WARRANTIES, EXPRESS AND IMPLIED, INCLUDING WITHOUT LIMITATION ANY IMPLIED WARRANTIES OF MERCHANTABILITY, FITNESS FOR A PARTICULAR PURPOSE OR NON-INFRINGEMENT OF THIRD PARTY INTELLECTUAL PROPERTY RIGHTS.

These resources are intended for skilled developers designing with TI products. You are solely responsible for (1) selecting the appropriate TI products for your application, (2) designing, validating and testing your application, and (3) ensuring your application meets applicable standards, and any other safety, security, or other requirements. These resources are subject to change without notice. TI grants you permission to use these resources only for development of an application that uses the TI products described in the resource. Other reproduction and display of these resources is prohibited. No license is granted to any other TI intellectual property right or to any third party intellectual property right. TI disclaims responsibility for, and you will fully indemnify TI and its representatives against, any claims, damages, costs, losses, and liabilities arising out of your use of these resources.

TI's products are provided subject to TI's Terms of Sale (www.ti.com/legal/termsofsale.html) or other applicable terms available either on ti.com or provided in conjunction with such TI products. TI's provision of these resources does not expand or otherwise alter TI's applicable warranties or warranty disclaimers for TI products.

Mailing Address: Texas Instruments, Post Office Box 655303, Dallas, Texas 75265
Copyright © 2019, Texas Instruments Incorporated

Looking for pricing, stock, or lifecycle information?

Click below to explore more details on WIN SOURCE:

- ⊖ [View MSP430F2132QRHBTEP on WIN SOURCE](#)
- ⊖ [Texas Instruments Information](#)

Optimize Your Supply Chain with WIN SOURCE Solutions

- ✓ Global Sourcing Solution
- ✓ Obsolete Management
- ✓ Cost Control Management
- ✓ Shortage Management
- ✓ Alternative Solution
- ✓ Excess Inventory Management