



# THE DATASHEET OF MSP430F112IDWR



# MSP430F11x MIXED SIGNAL MICROCONTROLLER

SLAS256D – NOVEMBER 1999 – REVISED SEPTEMBER 2004

- Low Supply Voltage Range 1.8 V to 3.6 V
- Ultralow-Power Consumption:
  - Active Mode: 200  $\mu$ A at 1 MHz, 2.2 V
  - Standby Mode: 0.8  $\mu$ A
  - Off Mode (RAM Retention): 0.1  $\mu$ A
- Wake-Up From Standby Mode in less than 6  $\mu$ s
- 16-Bit RISC Architecture, 125 ns Instruction Cycle Time
- Basic Clock Module Configurations:
  - Various Internal Resistors
  - Single External Resistor
  - 32 kHz Crystal
  - High Frequency Crystal
  - Resonator
  - External Clock Source
- 16-Bit Timer\_A With Three Capture/Compare Registers
- Serial Onboard Programming, No External Programming Voltage Needed
- Family Members Include:
  - MSP430F110: 1KB + 128B Flash Memory  
128B RAM
  - MSP430F112: 4KB + 256B Flash Memory  
256B RAM
- Available in a 20-Pin Plastic Small-Outline Wide Body (SOWB) Package and 20-Pin Plastic Thin Shrink Small-Outline Package (TSSOP)
- For Complete Module Descriptions, Refer to the *MSP430x1xx Family User's Guide*, Literature Number SLAU049

DW OR PW PACKAGE  
(TOP VIEW)

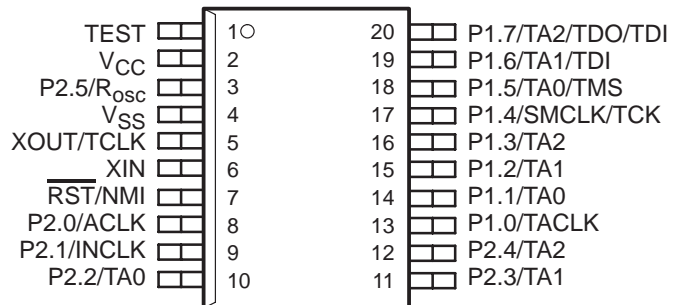

## description

The Texas Instruments MSP430 family of ultralow power microcontrollers consist of several devices featuring different sets of peripherals targeted for various applications. The architecture, combined with five low power modes is optimized to achieve extended battery life in portable measurement applications. The device features a powerful 16-bit RISC CPU, 16-bit registers, and constant generators that attribute to maximum code efficiency. The digitally controlled oscillator (DCO) allows wake-up from low-power modes to active mode in less than 6 $\mu$ s.

The MSP430F11x series is an ultralow-power mixed signal microcontroller with a built in 16-bit timer and fourteen I/O pins.

Typical applications include sensor systems that capture analog signals, convert them to digital values, and then process the data and display them or transmit them to a host system. Stand alone RF sensor front-end is another area of application.



Please be aware that an important notice concerning availability, standard warranty, and use in critical applications of Texas Instruments semiconductor products and disclaimers thereto appears at the end of this data sheet.

PRODUCTION DATA information is current as of publication date. Products conform to specifications per the terms of Texas Instruments standard warranty. Production processing does not necessarily include testing of all parameters.



POST OFFICE BOX 655303 • DALLAS, TEXAS 75265

Copyright © 1999 – 2004, Texas Instruments Incorporated

# MSP430F11x MIXED SIGNAL MICROCONTROLLER

SLAS256D – NOVEMBER 1999 – REVISED SEPTEMBER 2004

## AVAILABLE OPTIONS

T <sub>A</sub>	PACKAGED DEVICES	
	PLASTIC 20-PIN SOWB (DW)	PLASTIC 20-PIN TSSOP (PW)
-40°C to 85°C	MSP430F110IDW MSP430F112IDW	MSP430F110IPW MSP430F112IPW

## functional block diagram

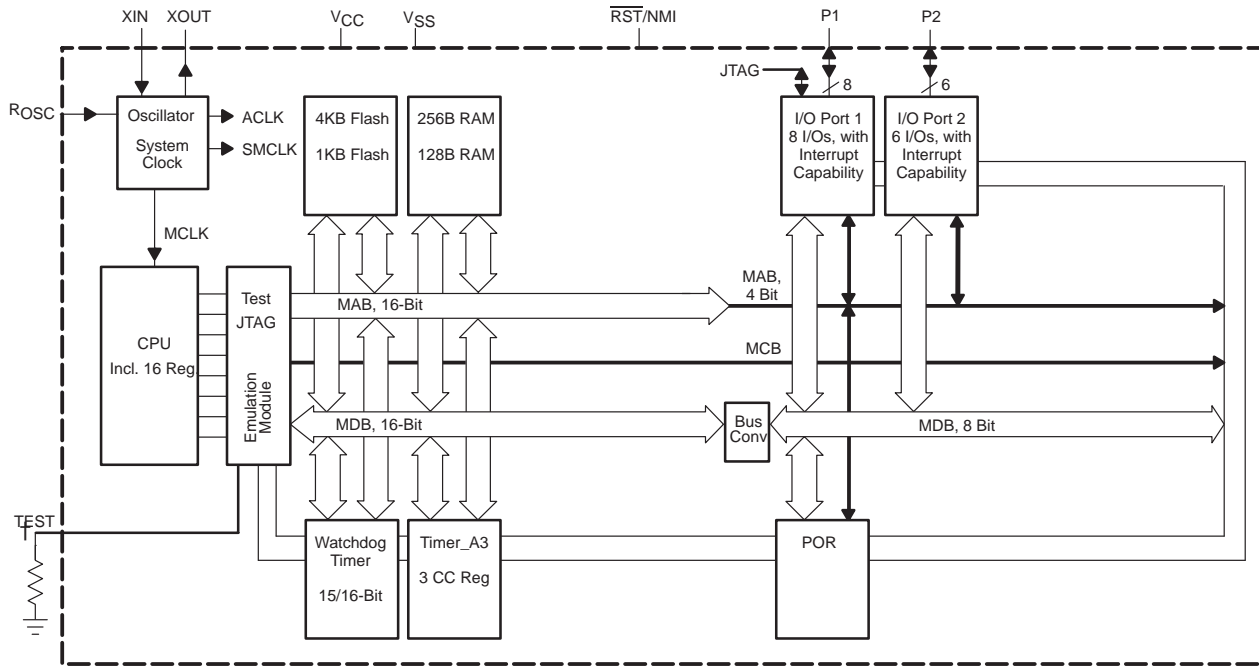

† A pull-down resistor of 30 kΩ is needed on F11x devices.

### Terminal Functions

TERMINAL NAME	NO.	I/O	DESCRIPTION
P1.0/TACLK	13	I/O	General-purpose digital I/O pin/Timer_A, clock signal TACLK input
P1.1/TA0	14	I/O	General-purpose digital I/O pin/Timer_A, capture: CCI0A input, compare: Out0 output/BSL transmit
P1.2/TA1	15	I/O	General-purpose digital I/O pin/Timer_A, capture: CCI1A input, compare: Out1 output
P1.3/TA2	16	I/O	General-purpose digital I/O pin/Timer_A, capture: CCI2A input, compare: Out2 output
P1.4/SMCLK/TCK	17	I/O	General-purpose digital I/O pin/SMCLK signal output/test clock, input terminal for device programming and test
P1.5/TA0/TMS	18	I/O	General-purpose digital I/O pin/Timer_A, compare: Out0 output/test mode select, input terminal for device programming and test
P1.6/TA1/TDI	19	I/O	General-purpose digital I/O pin/Timer_A, compare: Out1 output/test data input terminal
P1.7/TA2/TDO/TDI†	20	I/O	General-purpose digital I/O pin/Timer_A, compare: Out2 output/test data output terminal or data input during programming
P2.0/ACLK	8	I/O	General-purpose digital I/O pin/ACLK output
P2.1/INCLK	9	I/O	General-purpose digital I/O pin/Timer_A, clock signal at INCLK
P2.2/TA0	10	I/O	General-purpose digital I/O pin/Timer_A, capture: CCI0B input, compare: Out0 output/BSL receive
P2.3/TA1	11	I/O	General-purpose digital I/O pin/Timer_A, capture: CCI1B input, compare: Out1 output
P2.4/TA2	12	I/O	General-purpose digital I/O pin/Timer_A, compare: Out2 output
P2.5/ROSC	3	I/O	General-purpose digital I/O pin/Input for external resistor that defines the DCO nominal frequency
RST/NMI	7	I	Reset or nonmaskable interrupt input
TEST	1	I	Selects test mode for JTAG pins on Port1. Must be tied low with less than 30 kΩ.
V <sub>CC</sub>	2		Supply voltage
V <sub>SS</sub>	4		Ground reference
XIN	6	I	Input terminal of crystal oscillator
XOUT/TCLK	5	I/O	Output terminal of crystal oscillator or test clock input

† TDO or TDI is selected via JTAG instruction.

# MSP430F11x MIXED SIGNAL MICROCONTROLLER

SLAS256D – NOVEMBER 1999 – REVISED SEPTEMBER 2004

## short-form description

### CPU

The MSP430 CPU has a 16-bit RISC architecture that is highly transparent to the application. All operations, other than program-flow instructions, are performed as register operations in conjunction with seven addressing modes for source operand and four addressing modes for destination operand.

The CPU is integrated with 16 registers that provide reduced instruction execution time. The register-to-register operation execution time is one cycle of the CPU clock.

Four of the registers, R0 to R3, are dedicated as program counter, stack pointer, status register, and constant generator respectively. The remaining registers are general-purpose registers.

Peripherals are connected to the CPU using data, address, and control buses, and can be handled with all instructions.

### instruction set

The instruction set consists of 51 instructions with three formats and seven address modes. Each instruction can operate on word and byte data. Table 1 shows examples of the three types of instruction formats; the address modes are listed in Table 2.

Program Counter	PC/R0
Stack Pointer	SP/R1
Status Register	SR/CG1/R2
Constant Generator	CG2/R3
General-Purpose Register	R4
General-Purpose Register	R5
General-Purpose Register	R6
General-Purpose Register	R7
General-Purpose Register	R8
General-Purpose Register	R9
General-Purpose Register	R10
General-Purpose Register	R11
General-Purpose Register	R12
General-Purpose Register	R13
General-Purpose Register	R14
General-Purpose Register	R15

**Table 1. Instruction Word Formats**

Dual operands, source-destination	e.g. ADD R4,R5	R4 + R5 ----> R5
Single operands, destination only	e.g. CALL R8	PC ---->(TOS), R8----> PC
Relative jump, un/conditional	e.g. JNE	Jump-on-equal bit = 0

**Table 2. Address Mode Descriptions**

ADDRESS MODE	S	D	SYNTAX	EXAMPLE	OPERATION
Register	●	●	MOV Rs,Rd	MOV R10,R11	R10 ----> R11
Indexed	●	●	MOV X(Rn),Y(Rm)	MOV 2(R5),6(R6)	M(2+R5)----> M(6+R6)
Symbolic (PC relative)	●	●	MOV EDE,TONI		M(EDE) ----> M(TONI)
Absolute	●	●	MOV &MEM,&TCDAT		M(MEM) ----> M(TCDAT)
Indirect	●		MOV @Rn,Y(Rm)	MOV @R10,Tab(R6)	M(R10) ----> M(Tab+R6)
Indirect autoincrement	●		MOV @Rn+,Rm	MOV @R10+,R11	M(R10) ----> R11 R10 + 2----> R10
Immediate	●		MOV #X,TONI	MOV #45,TONI	#45 ----> M(TONI)

NOTE: S = source D = destination



## operating modes

The MSP430 has one active mode and five software selectable low-power modes of operation. An interrupt event can wake up the device from any of the five low-power modes, service the request and restore back to the low-power mode on return from the interrupt program.

The following six operating modes can be configured by software:

- Active mode AM;
  - All clocks are active
- Low-power mode 0 (LPM0);
  - CPU is disabled  
ACLK and SMCLK remain active. MCLK is disabled
- Low-power mode 1 (LPM1);
  - CPU is disabled  
ACLK and SMCLK remain active. MCLK is disabled  
DCO's dc-generator is disabled if DCO not used in active mode
- Low-power mode 2 (LPM2);
  - CPU is disabled  
MCLK and SMCLK are disabled  
DCO's dc-generator remains enabled  
ACLK remains active
- Low-power mode 3 (LPM3);
  - CPU is disabled  
MCLK and SMCLK are disabled  
DCO's dc-generator is disabled  
ACLK remains active
- Low-power mode 4 (LPM4);
  - CPU is disabled  
ACLK is disabled  
MCLK and SMCLK are disabled  
DCO's dc-generator is disabled  
Crystal oscillator is stopped

# MSP430F11x MIXED SIGNAL MICROCONTROLLER

SLAS256D – NOVEMBER 1999 – REVISED SEPTEMBER 2004

## interrupt vector addresses

The interrupt vectors and the power-up starting address are located in the memory with an address range of 0FFFFh-0FFE0h. The vector contains the 16-bit address of the appropriate interrupt handler instruction sequence.

INTERRUPT SOURCE	INTERRUPT FLAG	SYSTEM INTERRUPT	WORD ADDRESS	PRIORITY
Power-up External reset Watchdog	WDTIFG (Note1) KEYV (Note 1)	Reset	0FFFEh	15, highest
NMI Oscillator fault Flash memory access violation	NMIIFG (Notes 1 and 5) OFIFG (Notes 1 and 5) ACCVIFG (Notes 1 and 5)	(non)-maskable, (non)-maskable, (non)-maskable	0FFFCCh	14
			0FFFAh	13
			0FFF8h	12
			0FFF6h	11
Watchdog timer	WDTIFG	maskable	0FFF4h	10
Timer_A3	TACCR0 CCIFG (Note 2)	maskable	0FFF2h	9
Timer_A3	TACCR1 and TACCR2 CCIFGs, TAIFG (Notes 1 and 2)	maskable	0FFF0h	8
			0FFEEh	7
			0FFECCh	6
			0FFEAh	5
			0FFE8h	4
I/O Port P2 (eight flags – see Note 3)	P2IFG.0 to P2IFG.7 (Notes 1 and 2)	maskable	0FFE6h	3
I/O Port P1 (eight flags)	P1IFG.0 to P1IFG.7 (Notes 1 and 2)	maskable	0FFE4h	2
			0FFE2h	1
			0FFE0h	0, lowest

- NOTES: 1. Multiple source flags  
 2. Interrupt flags are located in the module  
 3. There are eight Port P2 interrupt flags, but only six Port P2 I/O pins (P2.0–5) are implemented on the '11x devices.  
 4. Nonmaskable: neither the individual nor the general interrupt enable bit will disable an interrupt event.  
 5. (non)-maskable: the individual interrupt enable bit can disable an interrupt event, but the general interrupt enable cannot.



### special function registers

Most interrupt and module enable bits are collected into the lowest address space. Special function register bits that are not allocated to a functional purpose are not physically present in the device. Simple software access is provided with this arrangement.

#### interrupt enable 1 and 2

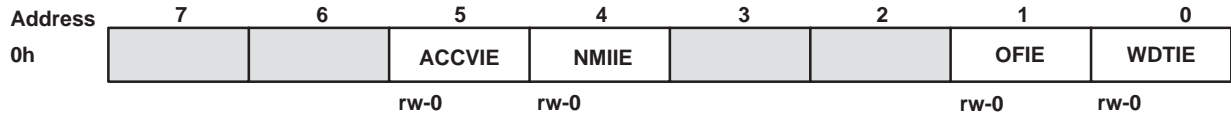

- WDTIE: Watchdog Timer interrupt enable. Inactive if watchdog mode is selected. Active if Watchdog Timer is configured in interval timer mode.
- OFIE: Oscillator fault enable
- NMIIE: Nonmaskable interrupt enable
- ACCVIE: Flash access violation interrupt enable

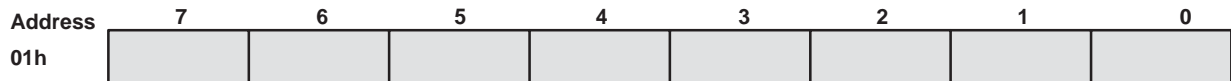

#### interrupt flag register 1 and 2



- WDTIFG: Set on Watchdog Timer overflow (in watchdog mode) or security key violation. Reset on  $V_{CC}$  power-up or a reset condition at RST/NMI pin in reset mode.
- OFIFG: Flag set on oscillator fault
- NMIIFG: Set via  $\overline{RST}/\overline{NMI}$ -pin

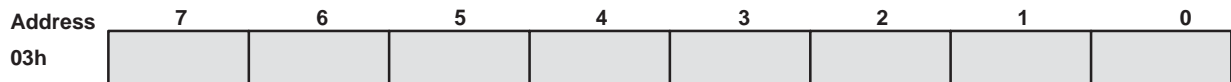

- Legend**
- rw:** Bit can be read and written.
- rw-0,1:** Bit can be read and written. It is Reset or Set by PUC.
- rw-(0,1):** Bit can be read and written. It is Reset or Set by POR.
- SFR bit is not present in device.

# MSP430F11x MIXED SIGNAL MICROCONTROLLER

SLAS256D – NOVEMBER 1999 – REVISED SEPTEMBER 2004

## memory organization

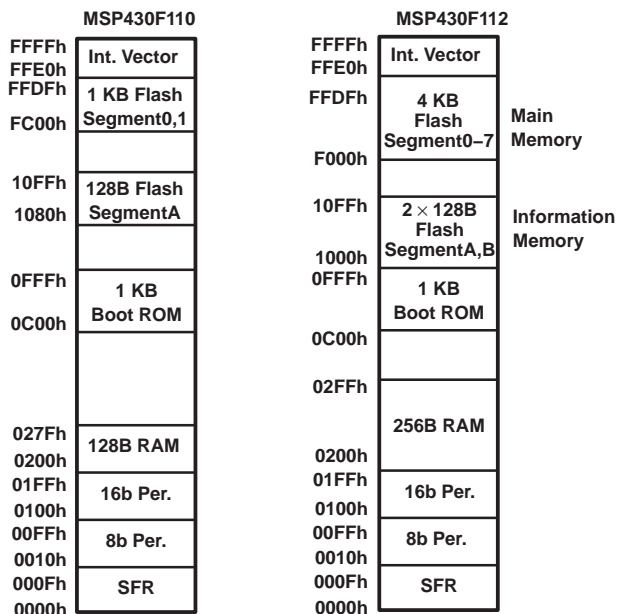

## bootstrap loader (BSL)

The MSP430 bootstrap loader (BSL) enables users to program the flash memory or RAM using a UART serial interface. Access to the MSP430 memory via the BSL is protected by user-defined password. For complete description of the features of the BSL and its implementation, see the Application report *Features of the MSP430 Bootstrap Loader*, Literature Number SLAA089.

BSL Function	DW & PW Package Pins
Data Transmit	14 - P1.1
Data Receive	10 - P2.2

## flash memory

The flash memory can be programmed via the JTAG port, the bootstrap loader, or in-system by the CPU. The CPU can perform single-byte and single-word writes to the flash memory. Features of the flash memory include:

- Flash memory has n segments of main memory and two segments of information memory (A and B) of 128 bytes each. Each segment in main memory is 512 bytes in size.
- Segments 0 to n may be erased in one step, or each segment may be individually erased.
- Segments A and B can be erased individually, or as a group with segments 0–n. Segments A and B are also called *information memory*.
- New devices may have some bytes programmed in the information memory (needed for test during manufacturing). The user should perform an erase of the information memory prior to the first use.

**flash memory (continued)**

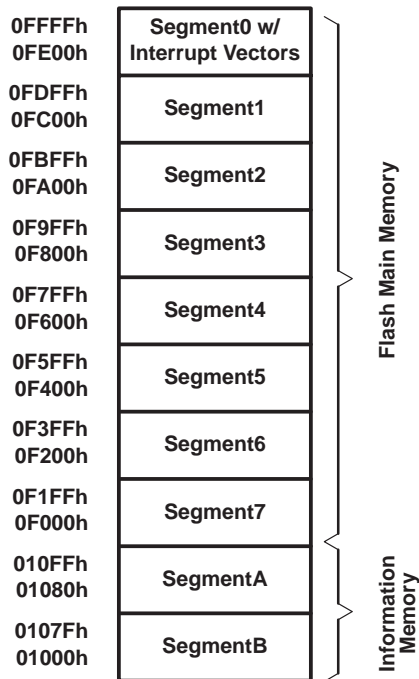

NOTE: All segments not implemented on all devices.

**peripherals**

Peripherals are connected to the CPU through data, address, and control busses and can be handled using all instructions. For complete module descriptions, refer to the *MSP430x1xx Family User's Guide*, literature number SLAU049.

**oscillator and system clock**

The clock system is supported by the basic clock module that includes support for a 32768-Hz watch crystal oscillator, an internal digitally-controlled oscillator (DCO) and a high frequency crystal oscillator. The basic clock module is designed to meet the requirements of both low system cost and low-power consumption. The internal DCO provides a fast turn-on clock source and stabilizes in less than 6  $\mu$ s. The basic clock module provides the following clock signals:

- Auxiliary clock (ACLK), sourced from a 32768-Hz watch crystal or a high frequency crystal.
- Main clock (MCLK), the system clock used by the CPU.
- Sub-Main clock (SMCLK), the sub-system clock used by the peripheral modules.

# MSP430F11x MIXED SIGNAL MICROCONTROLLER

SLAS256D – NOVEMBER 1999 – REVISED SEPTEMBER 2004

## digital I/O

There are two 8-bit I/O ports implemented—ports P1 and P2 (only six P2 I/O signals are available on external pins):

- All individual I/O bits are independently programmable.
- Any combination of input, output, and interrupt conditions is possible.
- Edge-selectable interrupt input capability for all the eight bits of port P1 and six bits of port P2.
- Read/write access to port-control registers is supported by all instructions.

### NOTE:

Six bits of port P2, P2.0 to P2.5, are available on external pins – but all control and data bits for port P2 are implemented.

## watchdog timer

The primary function of the watchdog timer (WDT) module is to perform a controlled system restart after a software problem occurs. If the selected time interval expires, a system reset is generated. If the watchdog function is not needed in an application, the module can be configured as an interval timer and can generate interrupts at selected time intervals.

## timer\_A3

Timer\_A3 is a 16-bit timer/counter with three capture/compare registers. Timer\_A3 can support multiple capture/compares, PWM outputs, and interval timing. Timer\_A3 also has extensive interrupt capabilities. Interrupts may be generated from the counter on overflow conditions and from each of the capture/compare registers.

Timer_A3 Signal Connections					
Input Pin Number	Device Input Signal	Module Input Name	Module Block	Module Output Signal	Output Pin Number
13 - P1.0	TACLK	TACLK	Timer	NA	
	ACLK	ACLK			
	SMCLK	SMCLK			
9 - P2.1	INCLK	INCLK			
14 - P1.1	TA0	CCI0A	CCR0	TA0	14 - P1.1
10 - P2.2	TA0	CCI0B			18 - P1.5
	DVSS	GND			10 - P2.2
	DVCC	VCC			
15 - P1.2	TA1	CCI1A	CCR1	TA1	15 - P1.2
11 - P2.3	TA1	CCI1B			19 - P1.6
	DVSS	GND			11 - P2.3
	DVCC	VCC			
16 - P1.3	TA2	CCI2A	CCR2	TA2	16 - P1.3
	ACLK (internal)	CCI2B			20 - P1.7
	DVSS	GND			12 - P2.4
	DVCC	VCC			



**peripheral file map**

<b>PERIPHERALS WITH WORD ACCESS</b>			
<b>Timer_A</b>	Reserved		017Eh
	Reserved		017Ch
	Reserved		017Ah
	Reserved		0178h
	Capture/compare register	TACCR2	0176h
	Capture/compare register	TACCR1	0174h
	Capture/compare register	TACCR0	0172h
	Timer_A register	TAR	0170h
	Reserved		016Eh
	Reserved		016Ch
	Reserved		016Ah
	Reserved		0168h
	Capture/compare control	TACCTL2	0166h
	Capture/compare control	TACCTL1	0164h
	Capture/compare control	TACCTL0	0162h
	Timer_A control	TACTL	0160h
Timer_A interrupt vector	TAIV	012Eh	
<b>Flash Memory</b>	Flash control 3	FCTL3	012Ch
	Flash control 2	FCTL2	012Ah
	Flash control 1	FCTL1	0128h
<b>Watchdog</b>	Watchdog/timer control	WDCTL	0120h
<b>PERIPHERALS WITH BYTE ACCESS</b>			
<b>Basic Clock</b>	Basic clock sys. control2	BCSCTL2	058h
	Basic clock sys. control1	BCSCTL1	057h
	DCO clock freq. control	DCOCTL	056h
<b>Port P2</b>	Port P2 selection	P2SEL	02Eh
	Port P2 interrupt enable	P2IE	02Dh
	Port P2 interrupt edge select	P2IES	02Ch
	Port P2 interrupt flag	P2IFG	02Bh
	Port P2 direction	P2DIR	02Ah
	Port P2 output	P2OUT	029h
	Port P2 input	P2IN	028h
<b>Port P1</b>	Port P1 selection	P1SEL	026h
	Port P1 interrupt enable	P1IE	025h
	Port P1 interrupt edge select	P1IES	024h
	Port P1 interrupt flag	P1IFG	023h
	Port P1 direction	P1DIR	022h
	Port P1 output	P1OUT	021h
	Port P1 input	P1IN	020h
<b>Special Function</b>	SFR interrupt flag2	IFG2	003h
	SFR interrupt flag1	IFG1	002h
	SFR interrupt enable2	IE2	001h
	SFR interrupt enable1	IE1	000h

# MSP430F11x MIXED SIGNAL MICROCONTROLLER

SLAS256D – NOVEMBER 1999 – REVISED SEPTEMBER 2004

## absolute maximum ratings†

Voltage applied at $V_{CC}$ to $V_{SS}$ .....	-0.3 V to 4.1 V
Voltage applied to any pin (referenced to $V_{SS}$ ) .....	-0.3 V to $V_{CC}+0.3$ V
Diode current at any device terminal .....	$\pm 2$ mA
Storage temperature, $T_{stg}$ (unprogrammed device) .....	-55°C to 150°C
Storage temperature, $T_{stg}$ (programmed device) .....	-40°C to 85°C

† Stresses beyond those listed under “absolute maximum ratings” may cause permanent damage to the device. These are stress ratings only, and functional operation of the device at these or any other conditions beyond those indicated under “recommended operating conditions” is not implied. Exposure to absolute-maximum-rated conditions for extended periods may affect device reliability.

NOTE: All voltages referenced to  $V_{SS}$ .

## recommended operating conditions

			MIN	NOM	MAX	UNITS
Supply voltage during program execution, $V_{CC}$ (see Note 1)			1.8		3.6	V
Supply voltage during program/erase flash memory, $V_{CC}$			2.7		3.6	V
Supply voltage, $V_{SS}$				0		V
Operating free-air temperature range, $T_A$			-40		85	°C
LFXT1 crystal frequency, $f_{(LFXT1)}$ (see Note 2)	LF mode selected, XTS=0	Watch crystal	32768			Hz
	XT1 mode selected, XTS=1	Ceramic resonator	450		8000	kHz
		Crystal	1000		8000	
Processor frequency $f_{(system)}$ (MCLK signal)		$V_{CC} = 1.8$ V	dc		2	MHz
		$V_{CC} = 2.2$ V	dc		5	MHz
		$V_{CC} = 3.6$ V	dc		8	MHz

- NOTES: 1. The LFXT1 oscillator in LF-mode requires a resistor of 5.1 M $\Omega$  from XOUT to  $V_{SS}$  when  $V_{CC} < 2.5$  V.  
 The LFXT1 oscillator in XT1-mode accepts a ceramic resonator or a crystal frequency of 4 MHz at  $V_{CC} \geq 2.2$  V.  
 The LFXT1 oscillator in XT1-mode accepts a ceramic resonator or a crystal frequency of 8 MHz at  $V_{CC} \geq 2.8$  V.  
 2. The LFXT1 oscillator in LF-mode requires a watch crystal. The LFXT1 oscillator in XT1-mode accepts a ceramic resonator or crystal.

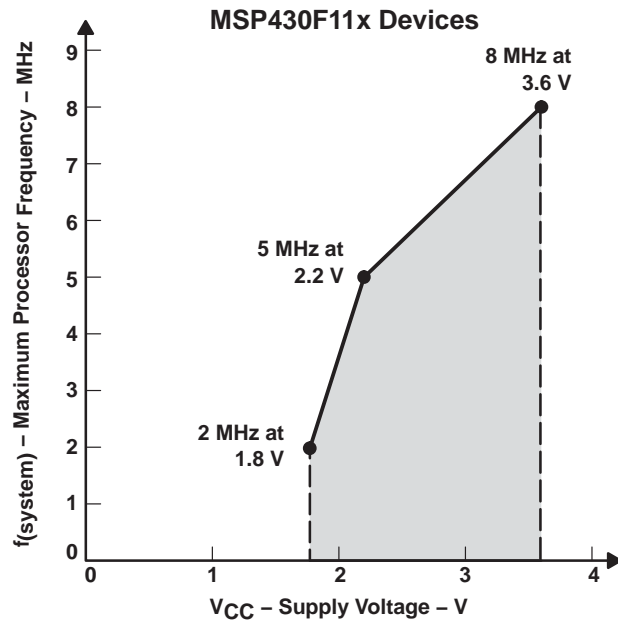

NOTE: Minimum processor frequency is defined by system clock. Flash program or erase operations require a minimum  $V_{CC}$  of 2.7 V.

Figure 1. Frequency vs Supply Voltage



electrical characteristics over recommended ranges of supply voltage and operating free-air temperature (unless otherwise noted)

supply current (into  $V_{CC}$ ) excluding external current

PARAMETER	TEST CONDITIONS		MIN	TYP	MAX	UNIT		
$I_{(AM)}$ Active mode	$T_A = -40^\circ\text{C} + 85^\circ\text{C}$ , $f_{(MCLK)} = f_{(SMCLK)} = 1\text{ MHz}$ , $f_{(ACLK)} = 32,768\text{ Hz}$	$V_{CC} = 2.2\text{ V}$		200	250	$\mu\text{A}$		
		$V_{CC} = 3\text{ V}$		300	350			
	$T_A = -40^\circ\text{C} + 85^\circ\text{C}$ , $f_{(MCLK)} = f_{(SMCLK)} = f_{(ACLK)} = 4096\text{ Hz}$	$V_{CC} = 2.2\text{ V}$		1.6	3	$\mu\text{A}$		
		$V_{CC} = 3\text{ V}$		3	4.3			
$I_{(CPUOff)}$ Low-power mode, (LPM0)	$T_A = -40^\circ\text{C} + 85^\circ\text{C}$ , $f_{(MCLK)} = 0$ , $f_{(SMCLK)} = 1\text{ MHz}$ , $f_{(ACLK)} = 32,768\text{ Hz}$	$V_{CC} = 2.2\text{ V}$		32	45	$\mu\text{A}$		
		$V_{CC} = 3\text{ V}$		55	70			
$I_{(LPM2)}$ Low-power mode, (LPM2)	$T_A = -40^\circ\text{C} + 85^\circ\text{C}$ , $f_{(MCLK)} = f_{(SMCLK)} = 0\text{ MHz}$ , $f_{(ACLK)} = 32,768\text{ Hz}$ , $SCG0 = 0$	$V_{CC} = 2.2\text{ V}$		11	14	$\mu\text{A}$		
		$V_{CC} = 3\text{ V}$		17	22			
$I_{(LPM3)}$ Low-power mode, (LPM3)	$T_A = -40^\circ\text{C}$	$V_{CC} = 2.2\text{ V}$		0.8	1.2	$\mu\text{A}$		
			$T_A = 25^\circ\text{C}$		0.7		1	
			$T_A = 85^\circ\text{C}$		1.6		2.3	
	$T_A = -40^\circ\text{C}$		$V_{CC} = 3\text{ V}$		1.8	2.2	$\mu\text{A}$	
				$T_A = 25^\circ\text{C}$		1.6		1.9
				$T_A = 85^\circ\text{C}$		2.3		3.4
$I_{(LPM4)}$ Low-power mode, (LPM4)	$f_{(MCLK)} = 0\text{ MHz}$ $f_{(SMCLK)} = 0\text{ MHz}$ , $f_{(ACLK)} = 0\text{ Hz}$ , $SCG0 = 1$	$V_{CC} = 2.2\text{ V}/3\text{ V}$		$T_A = -40^\circ\text{C}$	0.1	0.5	$\mu\text{A}$	
				$T_A = 25^\circ\text{C}$	0.1	0.5		
				$T_A = 85^\circ\text{C}$	0.8	1.9		

NOTE: All inputs are tied to 0 V or  $V_{CC}$ . Outputs do not source or sink any current.

current consumption of active mode versus system frequency, F version

$$I_{AM} = I_{AM}[1\text{ MHz}] \times f_{\text{system}} [\text{MHz}]$$

current consumption of active mode versus supply voltage, F version

$$I_{AM} = I_{AM}[3\text{ V}] + 120\ \mu\text{A/V} \times (V_{CC} - 3\text{ V})$$

# MSP430F11x MIXED SIGNAL MICROCONTROLLER

SLAS256D – NOVEMBER 1999 – REVISED SEPTEMBER 2004

electrical characteristics over recommended ranges of supply voltage and operating free-air temperature (unless otherwise noted)

## Schmitt-trigger inputs Port 1 to Port P2; P1.0 to P1.7, P2.0 to P2.5

PARAMETER		TEST CONDITIONS	MIN	TYP	MAX	UNIT
V <sub>IT+</sub>	Positive-going input threshold voltage	V <sub>CC</sub> = 2.2 V	1.1		1.3	V
		V <sub>CC</sub> = 3 V	1.5		1.8	
V <sub>IT-</sub>	Negative-going input threshold voltage	V <sub>CC</sub> = 2.2 V	0.4		0.9	V
		V <sub>CC</sub> = 3 V	.90		1.2	
V <sub>hys</sub>	Input voltage hysteresis, (V <sub>IT+</sub> – V <sub>IT-</sub> )	V <sub>CC</sub> = 2.2 V	0.3		1	V
		V <sub>CC</sub> = 3 V	0.5		1.4	

## standard inputs – $\overline{\text{RST/NMI}}$ ; TCK, TMS, TDI

PARAMETER		TEST CONDITIONS	MIN	TYP	MAX	UNIT
V <sub>IL</sub>	Low-level input voltage	V <sub>CC</sub> = 2.2 V / 3 V	V <sub>SS</sub>		V <sub>SS</sub> +0.6	V
V <sub>IH</sub>	High-level input voltage		0.8×V <sub>CC</sub>		V <sub>CC</sub>	V

## inputs P<sub>x.x</sub>, TAx

PARAMETER		TEST CONDITIONS	V <sub>CC</sub>	MIN	TYP	MAX	UNIT
t <sub>(int)</sub>	External interrupt timing	Port P1, P2: P1.x to P2.x, External trigger signal for the interrupt flag, (see Note 1)	2.2 V/3 V	1.5			cycle
			2.2 V	62			ns
			3 V	50			
t <sub>(cap)</sub>	Timer_A, capture timing	TA0, TA1, TA2 (see Note 2)	2.2 V/3 V	1.5			cycle
			2.2 V	62			ns
			3 V	50			
f <sub>(TAext)</sub>	Timer_A clock frequency externally applied to pin	TACLK, INCLK t <sub>(H)</sub> = t <sub>(L)</sub>	2.2 V			8	MHz
			3 V			10	
f <sub>(TAint)</sub>	Timer_A clock frequency	SMCLK or ACLK signal selected	2.2 V			8	MHz
			3 V			10	

- NOTES: 1. The external signal sets the interrupt flag every time the minimum t<sub>(int)</sub> cycle and time parameters are met. It may be set even with trigger signals shorter than t<sub>(int)</sub>. Both the cycle and timing specifications must be met to ensure the flag is set. t<sub>(int)</sub> is measured in MCLK cycles.
2. The external capture signal triggers the capture event every time the minimum t<sub>(cap)</sub> cycle and time parameters are met. A capture may be triggered with capture signals even shorter than t<sub>(cap)</sub>. Both the cycle and timing specifications must be met to ensure a correct capture of the 16-bit timer value and to ensure the flag is set.

## leakage current

PARAMETER		TEST CONDITIONS	MIN	TYP	MAX	UNIT
I <sub>lkg</sub> (P <sub>x.x</sub> )	High-impedance leakage current	Port P1: P1.x, 0 ≤ x ≤ 7 (see Notes 1 and 2)	V <sub>CC</sub> = 2.2 V/3 V,		±50	nA
		Port P2: P2.x, 0 ≤ x ≤ 5 (see Notes 1 and 2)	V <sub>CC</sub> = 2.2 V/3 V,		±50	

- NOTES: 1. The leakage current is measured with V<sub>SS</sub> or V<sub>CC</sub> applied to the corresponding pin(s), unless otherwise noted.
2. The leakage of the digital port pins is measured individually. The port pin must be selected for input and there must be no optional pullup or pulldown resistor.



**electrical characteristics over recommended ranges of supply voltage and operating free-air temperature (unless otherwise noted)**

**outputs Port 1 to Port 2; P1.0 to P1.7, P2.0 to P2.5**

PARAMETER		TEST CONDITIONS		MIN	TYP	MAX	UNIT
V <sub>OH</sub>	High-level output voltage Port 1	I <sub>(OHmax)</sub> = -1.5 mA	V <sub>CC</sub> = 2.2 V	See Note 1	V <sub>CC</sub> -0.25	V <sub>CC</sub>	V
		I <sub>(OHmax)</sub> = -6 mA					
		I <sub>(OHmax)</sub> = -1.5 mA	V <sub>CC</sub> = 3 V	See Note 1	V <sub>CC</sub> -0.25	V <sub>CC</sub>	
		I <sub>(OHmax)</sub> = -6 mA					
V <sub>OH</sub>	High-level output voltage Port 2	I <sub>(OHmax)</sub> = -1 mA	V <sub>CC</sub> = 2.2 V	See Note 3	V <sub>CC</sub> -0.25	V <sub>CC</sub>	V
		I <sub>(OHmax)</sub> = -3.4 mA					
		I <sub>(OHmax)</sub> = -1 mA	V <sub>CC</sub> = 3 V	See Note 3	V <sub>CC</sub> -0.25	V <sub>CC</sub>	
		I <sub>(OHmax)</sub> = -3.4 mA					
V <sub>OL</sub>	Low-level output voltage Port 1 and Port 2	I <sub>(OLmax)</sub> = 1.5 mA	V <sub>CC</sub> = 2.2 V	See Note 1	V <sub>SS</sub>	V <sub>SS</sub> +0.25	V
		I <sub>(OLmax)</sub> = 6 mA					
		I <sub>(OLmax)</sub> = 1.5 mA	V <sub>CC</sub> = 3 V	See Note 1	V <sub>SS</sub>	V <sub>SS</sub> +0.25	
		I <sub>(OLmax)</sub> = 6 mA					

- NOTES: 1. The maximum total current, I<sub>OHmax</sub> and I<sub>OLmax</sub>, for all outputs combined, should not exceed ±12 mA to hold the maximum voltage drop specified.  
 2. The maximum total current, I<sub>OHmax</sub> and I<sub>OLmax</sub>, for all outputs combined, should not exceed ±48 mA to hold the maximum voltage drop specified.  
 3. One output loaded at a time.

**outputs P1.x, P2.x, TAx**

PARAMETER		TEST CONDITIONS		V <sub>CC</sub>	MIN	TYP	MAX	UNIT
f <sub>(P20)</sub>	Output frequency	P2.0/ACLK, C <sub>L</sub> = 20 pF		2.2 V/3 V	f <sub>System</sub>			MHz
f <sub>(TAX)</sub>		TA0, TA1, TA2, C <sub>L</sub> = 20 pF Internal clock source, SMCLK signal applied (See Note 1)			dc	f <sub>System</sub>		
t <sub>(Xdc)</sub>	Duty cycle of O/P frequency	P1.4/SMCLK, C <sub>L</sub> = 20 pF	f <sub>SMCLK</sub> = f <sub>LFXT1</sub> = f <sub>XT1</sub>	2.2 V/3 V	40%	50%	60%	
			f <sub>SMCLK</sub> = f <sub>LFXT1</sub> = f <sub>LF</sub>		35%	50%	65%	
			f <sub>SMCLK</sub> = f <sub>LFXT1</sub> /n		50%– 15 ns	50%	50%+ 15 ns	
		f <sub>SMCLK</sub> = f <sub>DCOCLK</sub>	2.2 V/3 V	50%– 15 ns	50%	50%+ 15 ns		
t <sub>(TAdc)</sub>		P2.0/ACLK, C <sub>L</sub> = 20 pF	f <sub>P20</sub> = f <sub>LFXT1</sub> = f <sub>XT1</sub>	2.2 V/3 V	40%	50%	60%	ns
			f <sub>P20</sub> = f <sub>LFXT1</sub> = f <sub>LF</sub>		30%	50%	70%	
			f <sub>P20</sub> = f <sub>LFXT1</sub> /n		50%	50%	50%	
t <sub>(TAdc)</sub>		TA0, TA1, TA2, C <sub>L</sub> = 20 pF, Duty cycle = 50%	2.2 V/3 V	0		±50	ns	

NOTE 1: The limits of the system clock MCLK have to be met. MCLK and SMCLK can have different frequencies.

# MSP430F11x MIXED SIGNAL MICROCONTROLLER

SLAS256D – NOVEMBER 1999 – REVISED SEPTEMBER 2004

electrical characteristics over recommended ranges of supply voltage and operating free-air temperature (unless otherwise noted) (continued)

## PUC/POR

PARAMETER		TEST CONDITIONS		MIN	TYP	MAX	UNIT
$t(\text{POR\_Delay})$	POR	$V_{CC} = 2.2 \text{ V}/3 \text{ V}$			150	250	$\mu\text{s}$
$V_{\text{POR}}$			$T_A = -40^\circ\text{C}$	1.4	1.8	V	
			$T_A = 25^\circ\text{C}$	1.1	1.5	V	
			$T_A = 85^\circ\text{C}$	0.8	1.2	V	
$V(\text{min})$			0	0.4	V		
$t(\text{reset})$	PUC/POR	Reset is accepted internally		2		$\mu\text{s}$	

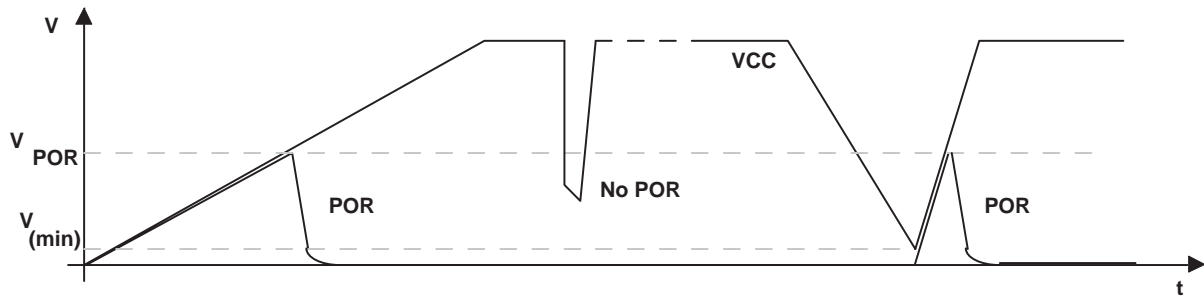

Figure 2. Power-On Reset (POR) vs Supply Voltage

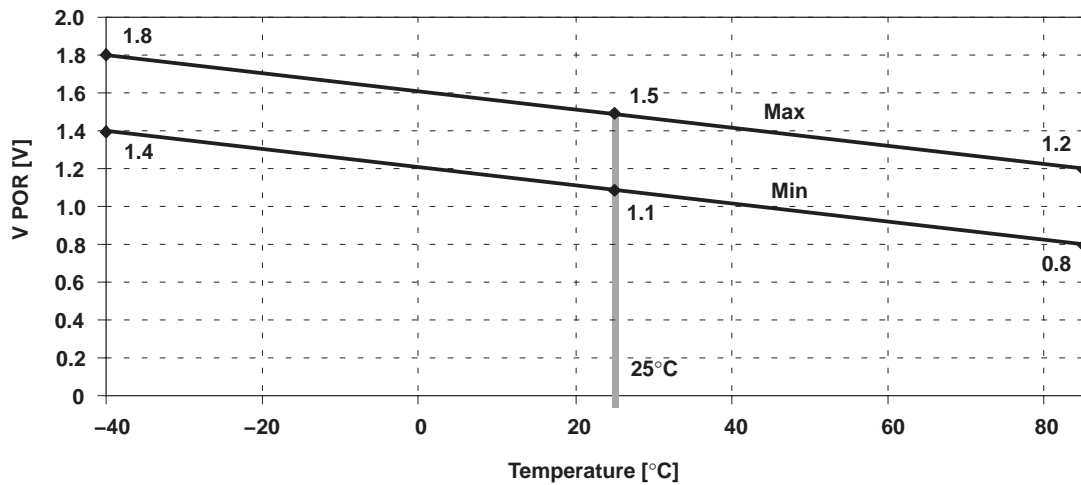

Figure 3.  $V_{\text{POR}}$  vs Temperature

**electrical characteristics over recommended ranges of supply voltage and operating free-air temperature (unless otherwise noted) (continued)**

**wake-up from lower power modes (LPMx)**

PARAMETER		TEST CONDITIONS	MIN	TYP	MAX	UNIT
t(LPM0)	Delay time (see Note 1)	V <sub>CC</sub> = 2.2 V/3 V		100		ns
t(LPM2)		V <sub>CC</sub> = 2.2 V/3 V		100		
t(LPM3)		f(MCLK) = 1 MHz, V <sub>CC</sub> = 2.2 V/3 V			6	μs
		f(MCLK) = 2 MHz, V <sub>CC</sub> = 2.2 V/3 V			6	
		f(MCLK) = 3 MHz, V <sub>CC</sub> = 2.2 V/3 V			6	
t(LPM4)		f(MCLK) = 1 MHz, V <sub>CC</sub> = 2.2 V/3 V			6	μs
		f(MCLK) = 2 MHz, V <sub>CC</sub> = 2.2 V/3 V			6	
		f(MCLK) = 3 MHz, V <sub>CC</sub> = 2.2 V/3 V			6	

NOTE 1: Parameter applicable only if DCOCLK is used for MCLK.

**RAM**

PARAMETER	MIN	TYP	MAX	UNIT
V(RAMh) CPU halted (see Note 1)	1.6			V

NOTE 1: This parameter defines the minimum supply voltage V<sub>CC</sub> when the data in the program memory RAM remains unchanged. No program execution should happen during this supply voltage condition.

# MSP430F11x MIXED SIGNAL MICROCONTROLLER

SLAS256D – NOVEMBER 1999 – REVISED SEPTEMBER 2004

electrical characteristics over recommended ranges of supply voltage and operating free-air temperature (unless otherwise noted) (continued)

## DCO

PARAMETER	TEST CONDITIONS	MIN	TYP	MAX	UNIT	
f(DCO03)	R <sub>sel</sub> = 0, DCO = 3, MOD = 0, DCOR = 0, T <sub>A</sub> = 25°C	V <sub>CC</sub> = 2.2 V	0.08	0.12	0.15	MHz
		V <sub>CC</sub> = 3 V	0.08	0.13	0.16	
f(DCO13)	R <sub>sel</sub> = 1, DCO = 3, MOD = 0, DCOR = 0, T <sub>A</sub> = 25°C	V <sub>CC</sub> = 2.2 V	0.14	0.19	0.23	MHz
		V <sub>CC</sub> = 3 V	0.14	0.18	0.22	
f(DCO23)	R <sub>sel</sub> = 2, DCO = 3, MOD = 0, DCOR = 0, T <sub>A</sub> = 25°C	V <sub>CC</sub> = 2.2 V	0.22	0.30	0.36	MHz
		V <sub>CC</sub> = 3 V	0.22	0.28	0.34	
f(DCO33)	R <sub>sel</sub> = 3, DCO = 3, MOD = 0, DCOR = 0, T <sub>A</sub> = 25°C	V <sub>CC</sub> = 2.2 V	0.37	0.49	0.59	MHz
		V <sub>CC</sub> = 3 V	0.37	0.47	0.56	
f(DCO43)	R <sub>sel</sub> = 4, DCO = 3, MOD = 0, DCOR = 0, T <sub>A</sub> = 25°C	V <sub>CC</sub> = 2.2 V	0.61	0.77	0.93	MHz
		V <sub>CC</sub> = 3 V	0.61	0.75	0.9	
f(DCO53)	R <sub>sel</sub> = 5, DCO = 3, MOD = 0, DCOR = 0, T <sub>A</sub> = 25°C	V <sub>CC</sub> = 2.2 V	1	1.2	1.5	MHz
		V <sub>CC</sub> = 3 V	1	1.3	1.5	
f(DCO63)	R <sub>sel</sub> = 6, DCO = 3, MOD = 0, DCOR = 0, T <sub>A</sub> = 25°C	V <sub>CC</sub> = 2.2 V	1.6	1.9	2.2	MHz
		V <sub>CC</sub> = 3 V	1.69	2.0	2.29	
f(DCO73)	R <sub>sel</sub> = 7, DCO = 3, MOD = 0, DCOR = 0, T <sub>A</sub> = 25°C	V <sub>CC</sub> = 2.2 V	2.4	2.9	3.4	MHz
		V <sub>CC</sub> = 3 V	2.7	3.2	3.65	
f(DCO77)	R <sub>sel</sub> = 7, DCO = 7, MOD = 0, DCOR = 0, T <sub>A</sub> = 25°C	V <sub>CC</sub> = 2.2 V	4	4.5	4.9	MHz
		V <sub>CC</sub> = 3 V	4.4	4.9	5.4	
f(DCO47)	R <sub>sel</sub> = 4, DCO = 7, MOD = 0, DCOR = 0, T <sub>A</sub> = 25°C	V <sub>CC</sub> = 2.2 V/3 V	F <sub>DCO40</sub> x1.7	F <sub>DCO40</sub> x2.1	F <sub>DCO40</sub> x2.5	MHz
S(Rsel)	S <sub>R</sub> = f <sub>Rsel+1</sub> /f <sub>Rsel</sub>	V <sub>CC</sub> = 2.2 V/3 V	1.35	1.65	2	ratio
S(DCO)	S <sub>DCO</sub> = f <sub>DCO+1</sub> /f <sub>DCO</sub>	V <sub>CC</sub> = 2.2 V/3 V	1.07	1.12	1.16	
D <sub>t</sub>	Temperature drift, R <sub>sel</sub> = 4, DCO = 3, MOD = 0 (see Note 1)	V <sub>CC</sub> = 2.2 V	-0.31	-0.36	-0.40	%/°C
		V <sub>CC</sub> = 3 V	-0.33	-0.38	-0.43	
D <sub>V</sub>	Drift with V <sub>CC</sub> variation, R <sub>sel</sub> = 4, DCO = 3, MOD = 0 (see Note 1)	V <sub>CC</sub> = 2.2 V/3 V	0	5	10	%/V

NOTE 1: These parameters are not production tested.

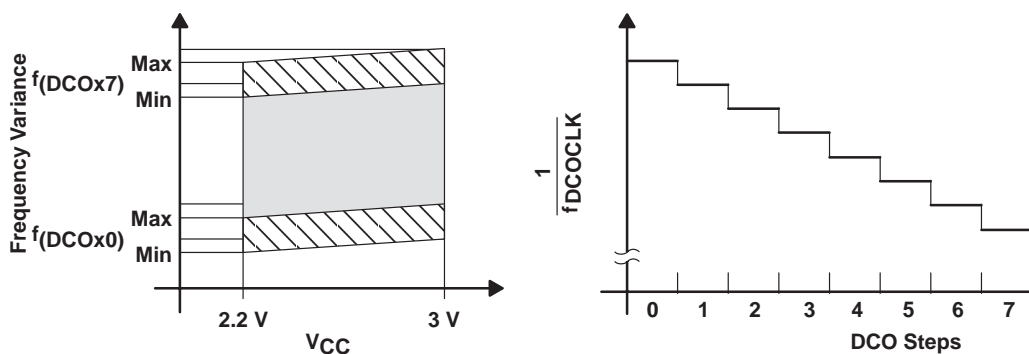

Figure 4. DCO Characteristics

**electrical characteristics over recommended ranges of supply voltage and operating free-air temperature (unless otherwise noted) (continued)**

**main DCO characteristics**

- Individual devices have a minimum and maximum operation frequency. The specified parameters for  $f_{(DCOx0)}$  to  $f_{(DCOx7)}$  are valid for all devices.
- All ranges selected by Rsel(n) overlap with Rsel(n+1): Rsel0 overlaps Rsel1, ... Rsel6 overlaps Rsel7.
- DCO control bits DCO0, DCO1, and DCO2 have a step size as defined by parameter  $S_{DCO}$ .
- Modulation control bits MOD0 to MOD4 select how often  $f_{(DCO+1)}$  is used within the period of 32 DCOCLK cycles. The frequency  $f_{(DCO)}$  is used for the remaining cycles. The frequency is an average equal to:

$$f_{average} = \frac{32 \times f_{(DCO)} \times f_{(DCO+1)}}{MOD \times f_{(DCO)} + (32 - MOD) \times f_{(DCO+1)}}$$

**crystal oscillator, LFXT1**

PARAMETER		TEST CONDITIONS	MIN	TYP	MAX	UNIT
CXIN	Input capacitance	XTS=0; LF mode selected. V <sub>CC</sub> = 2.2 V / 3 V		12		pF
		XTS=1; XT1 mode selected. V <sub>CC</sub> = 2.2 V / 3 V (Note 1)		2		
CXOUT	Output capacitance	XTS=0; LF mode selected. V <sub>CC</sub> = 2.2 V / 3 V		12		pF
		XTS=1; XT1 mode selected. V <sub>CC</sub> = 2.2 V / 3 V (Note 1)		2		
V <sub>IL</sub>	Input levels at XIN	V <sub>CC</sub> = 2.2 V/3 V (see Note 2)	V <sub>SS</sub>	0.2×V <sub>CC</sub>		V
V <sub>IH</sub>			0.8×V <sub>CC</sub>	V <sub>CC</sub>		

- NOTES: 1. The oscillator needs capacitors at both terminals, with values specified by the crystal manufacturer.  
2. Applies only when using an external logic-level clock source. Not applicable when using a crystal or resonator.

# MSP430F11x MIXED SIGNAL MICROCONTROLLER

SLAS256D – NOVEMBER 1999 – REVISED SEPTEMBER 2004

## electrical characteristics over recommended operating free-air temperature (unless otherwise noted) (continued)

### Flash Memory

PARAMETER		TEST CONDITIONS	V <sub>CC</sub>	MIN	NOM	MAX	UNIT
V <sub>CC</sub> (PGM/ERASE)	Program and Erase supply voltage			2.7		3.6	V
f <sub>FTG</sub>	Flash Timing Generator frequency			257		476	kHz
I <sub>PGM</sub>	Supply current from DV <sub>CC</sub> during program		2.7 V/ 3.6 V		3	5	mA
I <sub>ERASE</sub>	Supply current from DV <sub>CC</sub> during erase		2.7 V/ 3.6 V		3	5	mA
t <sub>CPT</sub>	Cumulative program time	see Note 1	2.7 V/ 3.6 V			4	ms
t <sub>CMErase</sub>	Cumulative mass erase time	see Note 2	2.7 V/ 3.6 V	200			ms
	Program/Erase endurance			10 <sup>4</sup>	10 <sup>5</sup>		cycles
t <sub>Retention</sub>	Data retention duration	T <sub>J</sub> = 25°C		100			years
t <sub>Word</sub>	Word or byte program time	see Note 3			35		t <sub>FTG</sub>
t <sub>Block, 0</sub>	Block program time for 1 <sup>st</sup> byte or word				30		
t <sub>Block, 1-63</sub>	Block program time for each additional byte or word				21		
t <sub>Block, End</sub>	Block program end-sequence wait time				6		
t <sub>Mass Erase</sub>	Mass erase time				5297		
t <sub>Seg Erase</sub>	Segment erase time				4819		

- NOTES: 1. The cumulative program time must not be exceeded when writing to a 64-byte flash block. This parameter applies to all programming methods: individual word/byte write and block write modes.
2. The mass erase duration generated by the flash timing generator is at least 11.1ms ( = 5297x1/f<sub>FTG,max</sub> = 5297x1/476kHz). To achieve the required cumulative mass erase time the Flash Controller's mass erase operation can be repeated until this time is met. (A worst case minimum of 19 cycles are required).
3. These values are hardwired into the Flash Controller's state machine (t<sub>FTG</sub> = 1/f<sub>FTG</sub>).

### JTAG Interface

PARAMETER		TEST CONDITIONS	V <sub>CC</sub>	MIN	NOM	MAX	UNIT
f <sub>TCK</sub>	TCK input frequency	see Note 1	2.2 V	0		5	MHz
			3 V	0		10	MHz
R <sub>Internal</sub>	Internal pull-up resistance on TMS, TCK, TDI/TCLK	see Note 2	2.2 V/ 3 V	25	60	90	kΩ

- NOTES: 1. f<sub>TCK</sub> may be restricted to meet the timing requirements of the module selected.
2. TMS, TDI/TCLK, and TCK pull-up resistors are implemented in all versions.



APPLICATION INFORMATION

input/output schematic

Port P1, P1.0 to P1.3, input/output with Schmitt-trigger

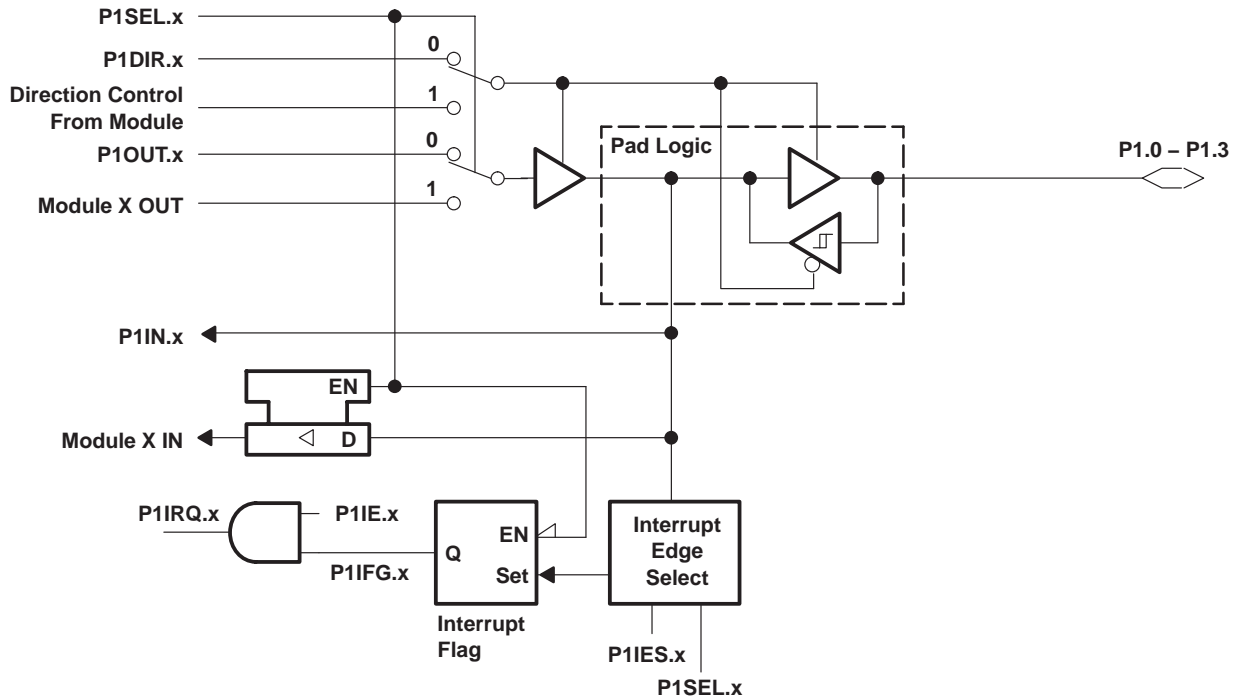

NOTE: x = Bit/identifier, 0 to 3 for port P1

PnSel.x	PnDIR.x	Direction control from module	PnOUT.x	Module X OUT	PnIN.x	Module X IN	PnIE.x	PnIFG.x	PnIES.x
P1Sel.0	P1DIR.0	P1DIR.0	P1OUT.0	V <sub>SS</sub>	P1IN.0	TACLK <sup>†</sup>	P1IE.0	P1IFG.0	P1IES.0
P1Sel.1	P1DIR.1	P1DIR.1	P1OUT.1	Out0 signal <sup>†</sup>	P1IN.1	CCI0A <sup>†</sup>	P1IE.1	P1IFG.1	P1IES.1
P1Sel.2	P1DIR.2	P1DIR.2	P1OUT.2	Out1 signal <sup>†</sup>	P1IN.2	CCI1A <sup>†</sup>	P1IE.2	P1IFG.2	P1IES.2
P1Sel.3	P1DIR.3	P1DIR.3	P1OUT.3	Out2 signal <sup>†</sup>	P1IN.3	CCI2A <sup>†</sup>	P1IE.3	P1IFG.3	P1IES.3

<sup>†</sup> Signal from or to Timer\_A

# MSP430F11x MIXED SIGNAL MICROCONTROLLER

SLAS256D – NOVEMBER 1999 – REVISED SEPTEMBER 2004

## APPLICATION INFORMATION

### input/output schematic (continued)

#### Port P1, P1.4 to P1.7, input/output with Schmitt-trigger and in-system access features

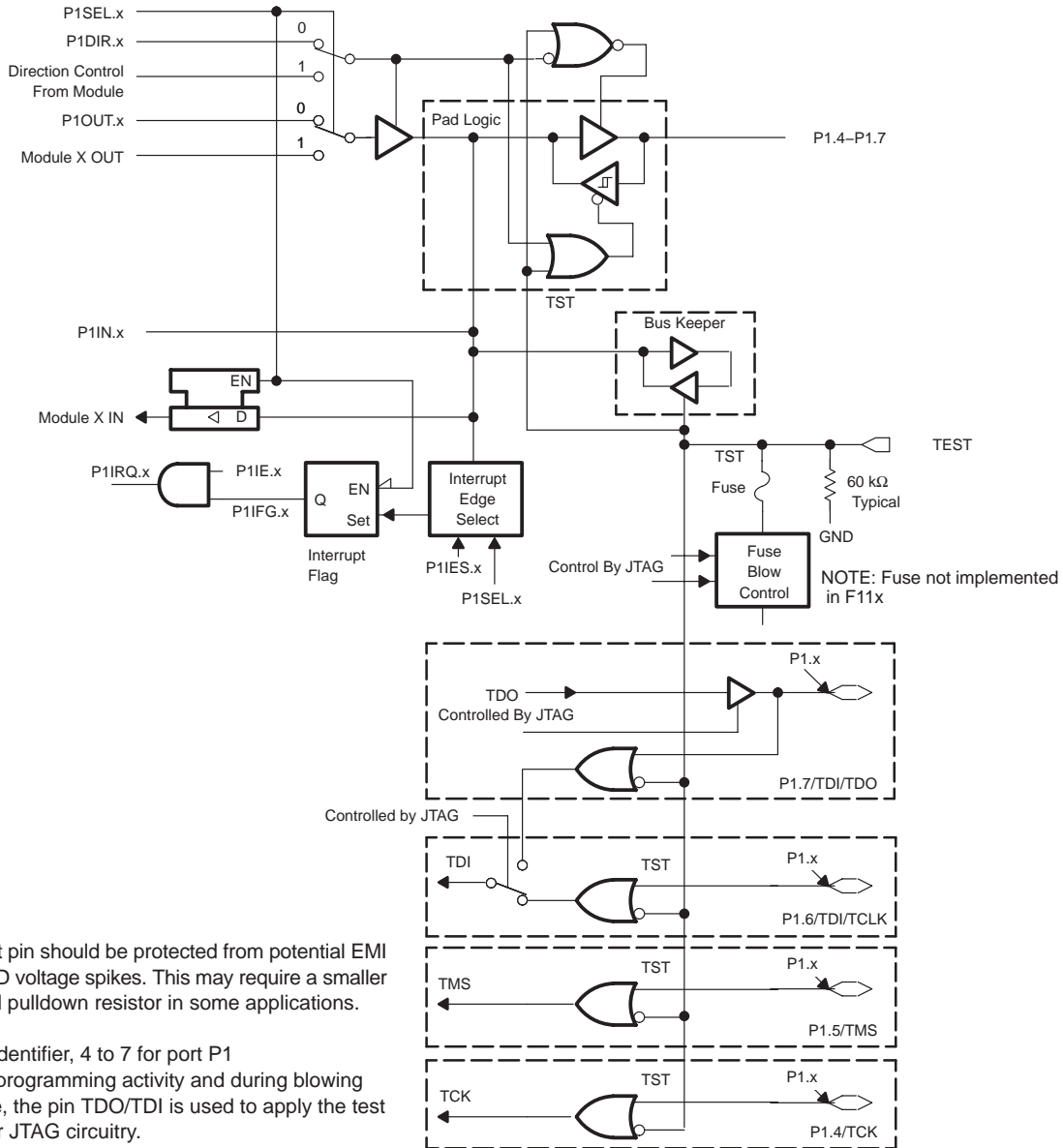

NOTE: The test pin should be protected from potential EMI and ESD voltage spikes. This may require a smaller external pulldown resistor in some applications.

x = Bit identifier, 4 to 7 for port P1  
During programming activity and during blowing the fuse, the pin TDO/TDI is used to apply the test input for JTAG circuitry.

PnSel.x	PnDIR.x	Direction control from module	PnOUT.x	Module X OUT	PnIN.x	Module X IN	PnIE.x	PnIFG.x	PnIES.x
P1Sel.4	P1DIR.4	P1DIR.4	P1OUT.4	SMCLK	P1IN.4	unused	P1IE.4	P1IFG.4	P1IES.4
P1Sel.5	P1DIR.5	P1DIR.5	P1OUT.5	Out0 signal <sup>†</sup>	P1IN.5	unused	P1IE.5	P1IFG.5	P1IES.5
P1Sel.6	P1DIR.6	P1DIR.6	P1OUT.6	Out1 signal <sup>†</sup>	P1IN.6	unused	P1IE.6	P1IFG.6	P1IES.6
P1Sel.7	P1DIR.7	P1DIR.7	P1OUT.7	Out2 signal <sup>†</sup>	P1IN.7	unused	P1IE.7	P1IFG.7	P1IES.7

<sup>†</sup> Signal from or to Timer\_A

APPLICATION INFORMATION

input/output schematic (continued)

Port P2, P2.0 to P2.4, input/output with Schmitt-trigger

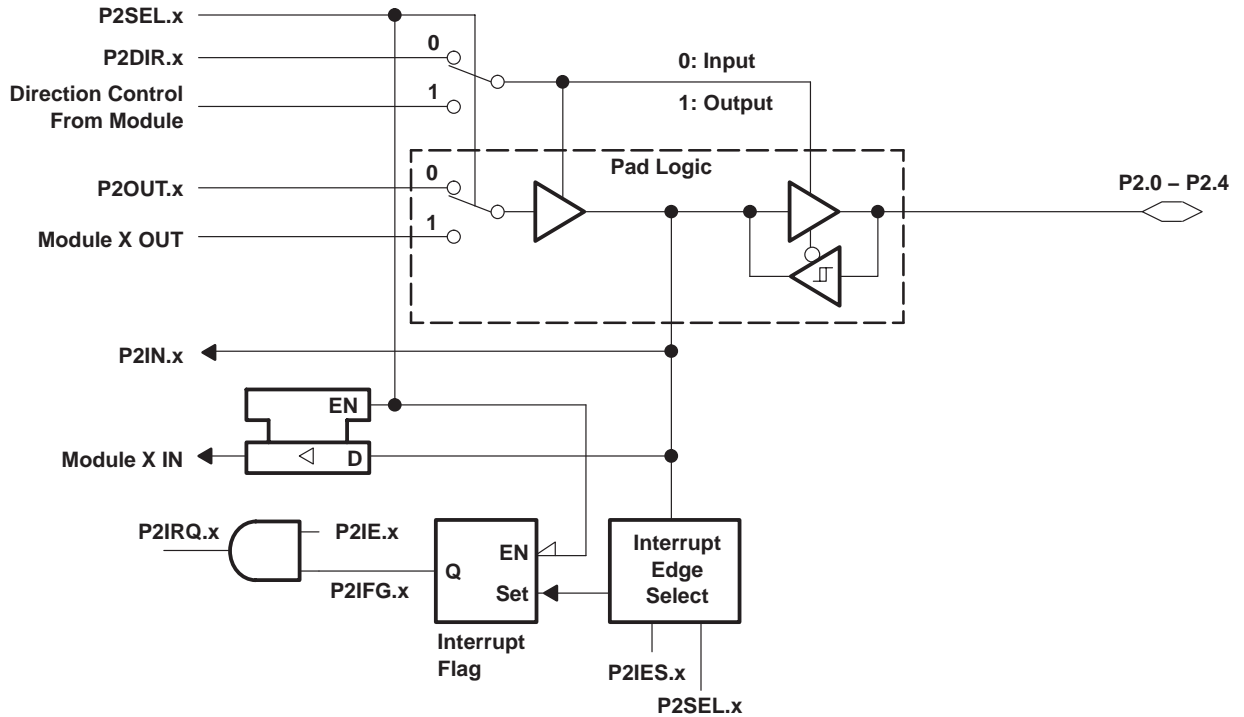

NOTE: x = Bit Identifier, 0 to 4 For Port P2

PnSel.x	PnDIR.x	Direction control from module	PnOUT.x	Module X OUT	PnIN.x	Module X IN	PnIE.x	PnIFG.x	PnIES.x
P2Sel.0	P2DIR.0	P2DIR.0	P2OUT.0	ACLK	P2IN.0	unused	P2IE.0	P2IFG.0	P1IES.0
P2Sel.1	P2DIR.1	P2DIR.1	P2OUT.1	VSS	P2IN.1	INCLK <sup>†</sup>	P2IE.1	P2IFG.1	P1IES.1
P2Sel.2	P2DIR.2	P2DIR.2	P2OUT.2	Out0 signal <sup>†</sup>	P2IN.2	CCI0B <sup>†</sup>	P2IE.2	P2IFG.2	P1IES.2
P2Sel.3	P2DIR.3	P2DIR.3	P2OUT.3	Out1 signal <sup>†</sup>	P2IN.3	CCI1B <sup>†</sup>	P2IE.3	P2IFG.3	P1IES.3
P2Sel.4	P2DIR.4	P2DIR.4	P2OUT.4	Out2 signal <sup>†</sup>	P2IN.4	unused	P2IE.4	P2IFG.4	P1IES.4

<sup>†</sup> Signal from or to Timer\_A

# MSP430F11x MIXED SIGNAL MICROCONTROLLER

SLAS256D – NOVEMBER 1999 – REVISED SEPTEMBER 2004

## APPLICATION INFORMATION

### input/output schematic (continued)

Port P2, P2.5, input/output with Schmitt-trigger and  $R_{OSC}$  function for the Basic Clock module

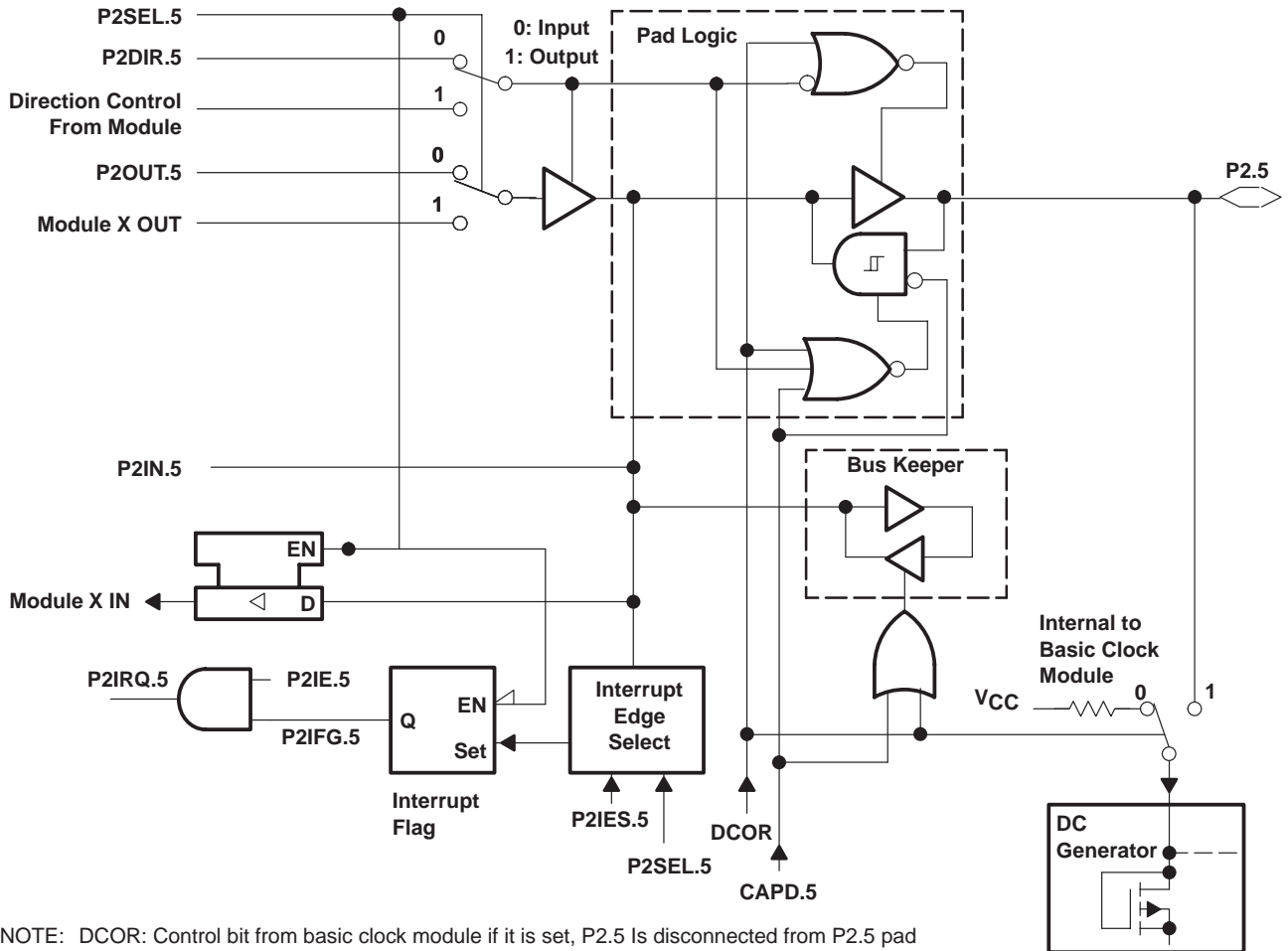

NOTE: DCOR: Control bit from basic clock module if it is set, P2.5 is disconnected from P2.5 pad

PnSel.x	PnDIR.x	Direction control from module	PnOUT.x	Module X OUT	PnIN.x	Module X IN	PnIE.x	PnIFG.x	PnIES.x
P2Sel.5	P2DIR.5	P2DIR.5	P2OUT.5	V <sub>SS</sub>	P2IN.5	unused	P2IE.5	P2IFG.5	P2IES.5

APPLICATION INFORMATION

input/output schematic (continued)

Port P2, unbonded bits P2.6 and P2.7

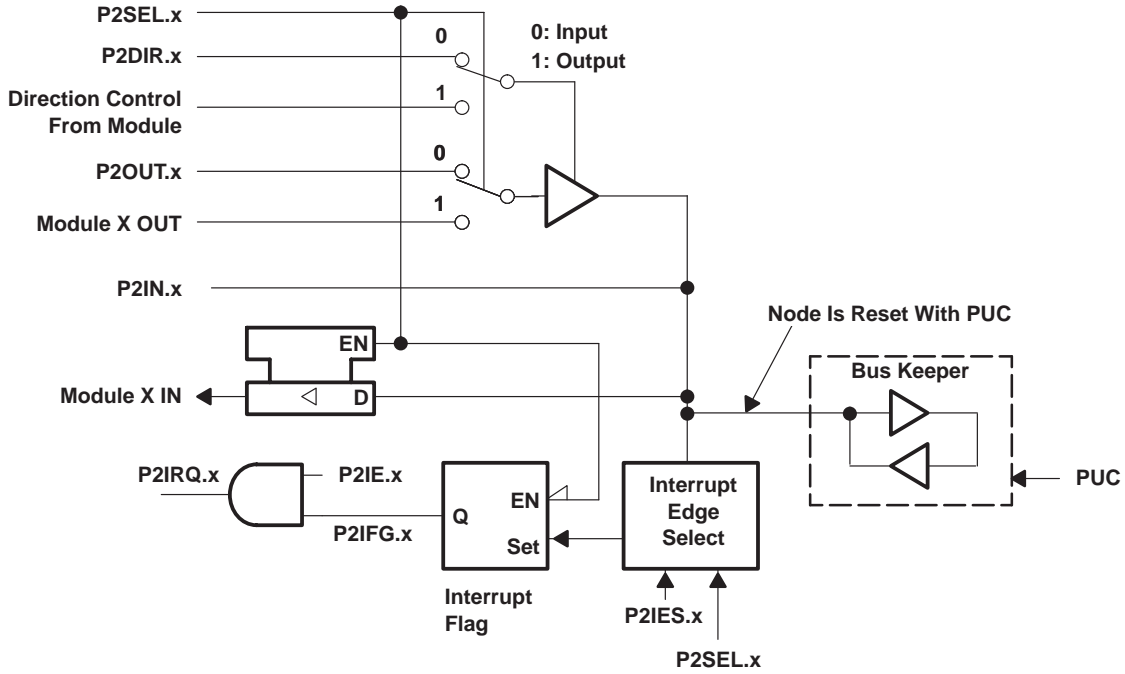

NOTE: x = Bit/identifier, 6 to 7 for port P2 without external pins

P2Sel.x	P2DIR.x	Direction control from module	P2OUT.x	Module X OUT	P2IN.x	Module X IN	P2IE.x	P2IFG.x	P2IES.x
P2Sel.6	P2DIR.6	P2DIR.6	P2OUT.6	V <sub>SS</sub>	P2IN.6	unused	P2IE.6	P2IFG.6	P2IES.6
P2Sel.7	P2DIR.7	P2DIR.7	P2OUT.7	V <sub>SS</sub>	P2IN.7	unused	P2IE.7	P2IFG.7	P2IES.7

NOTE: A good use of the unbonded bits 6 and 7 of port P2 is to use the interrupt flags. The interrupt flags can not be influenced from any signal other than from software. They work then as a soft interrupt.

# MSP430F11x MIXED SIGNAL MICROCONTROLLER

SLAS256D – NOVEMBER 1999 – REVISED SEPTEMBER 2004

---

## APPLICATION INFORMATION

### JTAG fuse check mode

The JTAG protection fuse is not implemented in the MSP430F11x devices.



**PACKAGING INFORMATION**

Orderable Device	Status (1)	Package Type	Package Drawing	Pins	Package Qty	Eco Plan (2)	Lead/Ball Finish (6)	MSL Peak Temp (3)	Op Temp (°C)	Device Marking (4/5)	Samples
MSP430F112IPW	ACTIVE	TSSOP	PW	20	70	Green (RoHS & no Sb/Br)	CU NIPDAU	Level-1-260C-UNLIM	-40 to 85	430F112	Samples

(1) The marketing status values are defined as follows:

**ACTIVE:** Product device recommended for new designs.

**LIFEBUY:** TI has announced that the device will be discontinued, and a lifetime-buy period is in effect.

**NRND:** Not recommended for new designs. Device is in production to support existing customers, but TI does not recommend using this part in a new design.

**PREVIEW:** Device has been announced but is not in production. Samples may or may not be available.

**OBSOLETE:** TI has discontinued the production of the device.

(2) **RoHS:** TI defines "RoHS" to mean semiconductor products that are compliant with the current EU RoHS requirements for all 10 RoHS substances, including the requirement that RoHS substance do not exceed 0.1% by weight in homogeneous materials. Where designed to be soldered at high temperatures, "RoHS" products are suitable for use in specified lead-free processes. TI may reference these types of products as "Pb-Free".

**RoHS Exempt:** TI defines "RoHS Exempt" to mean products that contain lead but are compliant with EU RoHS pursuant to a specific EU RoHS exemption.

**Green:** TI defines "Green" to mean the content of Chlorine (Cl) and Bromine (Br) based flame retardants meet JS709B low halogen requirements of <=1000ppm threshold. Antimony trioxide based flame retardants must also meet the <=1000ppm threshold requirement.

(3) MSL, Peak Temp. - The Moisture Sensitivity Level rating according to the JEDEC industry standard classifications, and peak solder temperature.

(4) There may be additional marking, which relates to the logo, the lot trace code information, or the environmental category on the device.

(5) Multiple Device Markings will be inside parentheses. Only one Device Marking contained in parentheses and separated by a "~" will appear on a device. If a line is indented then it is a continuation of the previous line and the two combined represent the entire Device Marking for that device.

(6) Lead/Ball Finish - Orderable Devices may have multiple material finish options. Finish options are separated by a vertical ruled line. Lead/Ball Finish values may wrap to two lines if the finish value exceeds the maximum column width.

**Important Information and Disclaimer:** The information provided on this page represents TI's knowledge and belief as of the date that it is provided. TI bases its knowledge and belief on information provided by third parties, and makes no representation or warranty as to the accuracy of such information. Efforts are underway to better integrate information from third parties. TI has taken and continues to take reasonable steps to provide representative and accurate information but may not have conducted destructive testing or chemical analysis on incoming materials and chemicals. TI and TI suppliers consider certain information to be proprietary, and thus CAS numbers and other limited information may not be available for release.

In no event shall TI's liability arising out of such information exceed the total purchase price of the TI part(s) at issue in this document sold by TI to Customer on an annual basis.



PW (R-PDSO-G20)

PLASTIC SMALL OUTLINE



- NOTES:
- A. All linear dimensions are in millimeters.
  - B. This drawing is subject to change without notice.
  - C. Publication IPC-7351 is recommended for alternate design.
  - D. Laser cutting apertures with trapezoidal walls and also rounding corners will offer better paste release. Customers should contact their board assembly site for stencil design recommendations. Refer to IPC-7525 for other stencil recommendations.
  - E. Customers should contact their board fabrication site for solder mask tolerances between and around signal pads.

## IMPORTANT NOTICE AND DISCLAIMER

TI PROVIDES TECHNICAL AND RELIABILITY DATA (INCLUDING DATASHEETS), DESIGN RESOURCES (INCLUDING REFERENCE DESIGNS), APPLICATION OR OTHER DESIGN ADVICE, WEB TOOLS, SAFETY INFORMATION, AND OTHER RESOURCES "AS IS" AND WITH ALL FAULTS, AND DISCLAIMS ALL WARRANTIES, EXPRESS AND IMPLIED, INCLUDING WITHOUT LIMITATION ANY IMPLIED WARRANTIES OF MERCHANTABILITY, FITNESS FOR A PARTICULAR PURPOSE OR NON-INFRINGEMENT OF THIRD PARTY INTELLECTUAL PROPERTY RIGHTS.

These resources are intended for skilled developers designing with TI products. You are solely responsible for (1) selecting the appropriate TI products for your application, (2) designing, validating and testing your application, and (3) ensuring your application meets applicable standards, and any other safety, security, or other requirements. These resources are subject to change without notice. TI grants you permission to use these resources only for development of an application that uses the TI products described in the resource. Other reproduction and display of these resources is prohibited. No license is granted to any other TI intellectual property right or to any third party intellectual property right. TI disclaims responsibility for, and you will fully indemnify TI and its representatives against, any claims, damages, costs, losses, and liabilities arising out of your use of these resources.

TI's products are provided subject to TI's Terms of Sale ([www.ti.com/legal/termsofsale.html](http://www.ti.com/legal/termsofsale.html)) or other applicable terms available either on [ti.com](http://ti.com) or provided in conjunction with such TI products. TI's provision of these resources does not expand or otherwise alter TI's applicable warranties or warranty disclaimers for TI products.

Mailing Address: Texas Instruments, Post Office Box 655303, Dallas, Texas 75265  
Copyright © 2018, Texas Instruments Incorporated

## Looking for pricing, stock, or lifecycle information?

Click below to explore more details on WIN SOURCE:

 [View MSP430F112IDWR on WIN SOURCE](#)

 [Texas Instruments](#) Information

## Optimize Your Supply Chain with WIN SOURCE Solutions

-  Global Sourcing Solution
-  Obsolete Management
-  Cost Control Management
-  Shortage Management
-  Alternative Solution
-  Excess Inventory Management