



# THE DATASHEET OF MPC17C724EPR2



# 0.4 A Dual H-Bridge Motor Driver IC

The 17C724 is a SMARTMOS compact monolithic dual channel H-Bridge power IC, ideal for portable electronic applications containing bipolar stepper motors or brush DC motors such as those used in camera lenses and shutters.

The 17C724 can operate efficiently with supply voltages from 2.7 V to 5.5 V and can provide continuous motor drive currents of 0.4 A with low  $R_{DS(on)}$  of 1.0  $\Omega$ . It is easily interfaced to low cost MCUs via parallel 3.0 V or 5.0 V compatible logic and has built-in shoot-through current protection circuit and undervoltage detector to avoid malfunction.

The 17C724 has four output control modes: forward, reverse, brake, and tri-state (high-impedance). The H-Bridge outputs are designed to be independently PWMed at up to 200 kHz for speed/torque and current control.

### Features

- Manufactured in SMOS7 process technology
- Built-in 2-channel H-Bridge driver
- Provides 4 driving modes (forward, reverse, brake, high-impedance)
- Direct interface to MCU
- Low ON-Resistance,  $R_{DS(on)} = 1.0 \Omega$  (typical)
- Dual channel parallel drive,  $R_{DS(on)} = 0.5 \Omega$  (typical)
- Output current driver is 400 mA (continuous)
- Low power consumption
- Built-in shoot-through current prevention circuit
- Built-in low voltage shutdown circuit
- PWM control frequency 200 kHz (max)
- Very compact size, comes in 16-pin QFN Package (3x3 mm pin Pitch: 0.5 mm)

17C724

MOTOR DRIVER

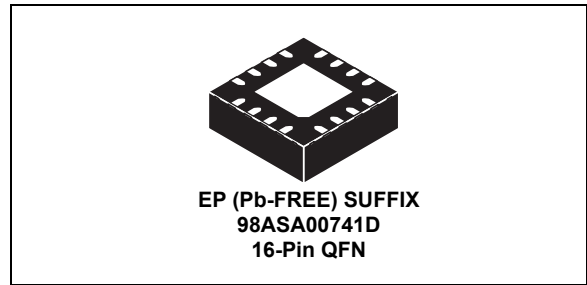

ORDERING INFORMATION		
Device (For Tape and Reel, add an R2 Suffix)	Temperature Range (T <sub>A</sub> )	Package
MPC17C724EP	-20 °C to 85 °C	16 QFN

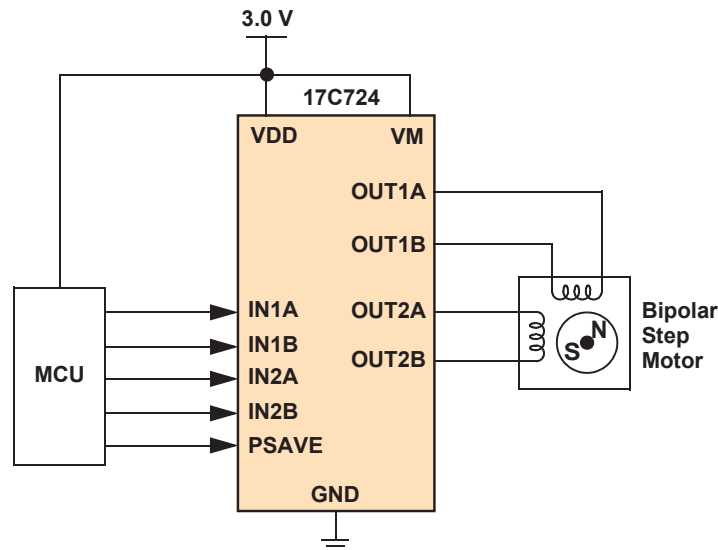

Figure 1. 17C724 Simplified Application Diagram

### INTERNAL BLOCK DIAGRAM

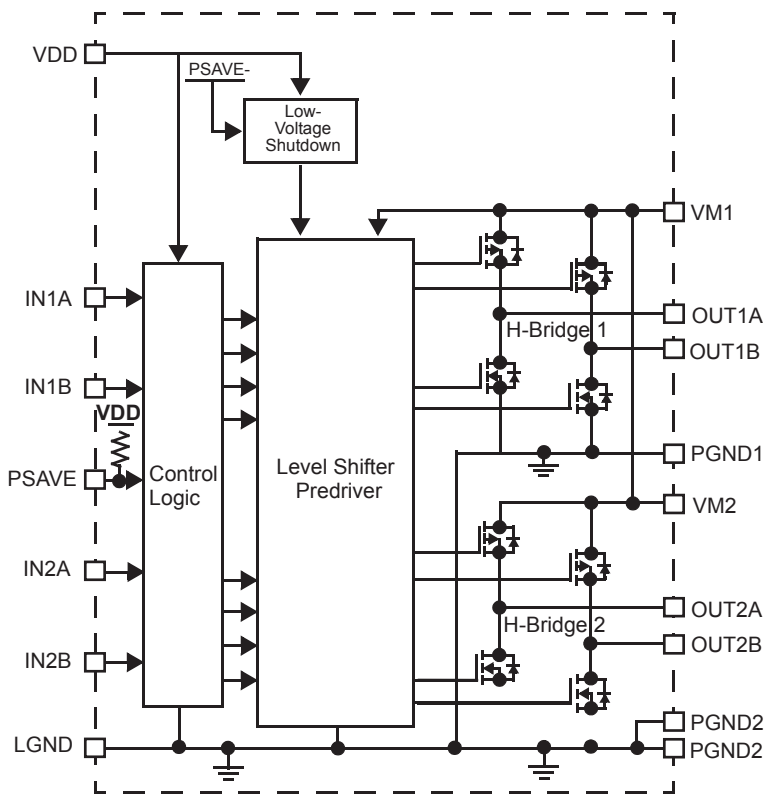
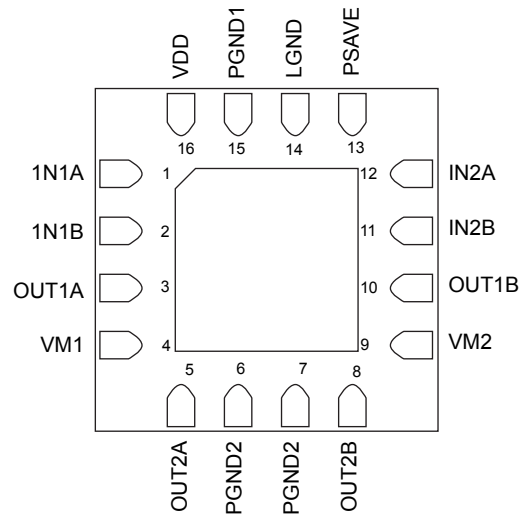

Figure 2. 17C724 Simplified Internal Block Diagram

## PIN CONNECTIONS

### Transparent Top View of Package



**Figure 3. 17C724 Pin Connections**

**Table 1. 17C724 Pin Definitions**

A functional description of each pin can be found in the Functional Pin Description section beginning on [page 8](#).

Pin Number	Pin Name	Pin Function	Formal Name	Definition
1	IN1A	Logic	Logic Input Control 1A	Logic input control of OUT1A (refer to <a href="#">Table 5. Truth Table</a> , page <a href="#">Z</a> ).
2	IN1B	Logic	Logic Input Control 1B	Logic input control of OUT1B (refer to <a href="#">Table 5. Truth Table</a> , page <a href="#">Z</a> ).
3	OUT1A	Output	H-Bridge Output 1A	Output A of H-Bridge channel 1.
4	VM1	Power	Motor Driver Power Supply 1	Positive power source connection for H-Bridge 1 (Motor Driver Power Supply) <sup>(1)</sup> .
5	OUT2A	Output	H-Bridge Output 2A	Output A of H-Bridge channel 2.
6, 7	PGND2	Ground	Power Ground 2	High-current power ground 2 <sup>(2)</sup> .
8	OUT2B	Output	H-Bridge Output 2B	Output B of H-Bridge channel 2.
9	VM2	Power	Motor Driver Power Supply 2	Positive power source connection for H-Bridge 2 (Motor Driver Power Supply) <sup>(1)</sup> .
10	OUT1B	Output	H-Bridge Output 1B	Output B of H-Bridge channel 1.
11	IN2B	Input	Logic Input Control 2B	Logic input control of OUT2B (refer to <a href="#">Table 5. Truth Table</a> , page <a href="#">Z</a> ).
12	IN2A	Input	Logic Input Control 2A	Logic input control of OUT2A (refer to <a href="#">Table 5. Truth Table</a> , page <a href="#">Z</a> ).
13	PSAVE	Input	Input Enable Control	Logic input enable control of H-Bridges to save power.
14	LGND	Ground	Logic Ground	Low-current logic signal ground <sup>(2)</sup> .
15	PGND1	Ground	Power Ground 1	High-current power ground 1 <sup>(2)</sup> .
16	VDD	Logic	Logic Circuit Power Supply	Positive power source connection for logic circuit.

**Notes**

- VM1 and VM2 are internally connected.
- LGND, PGND1, and PGND2 are internally connected.

## MAXIMUM RATINGS

**Table 2. Maximum Ratings**

All voltages are with respect to ground unless otherwise noted. Exceeding these ratings may cause a malfunction or permanent damage to the device.

Ratings	Symbol	Value	Unit
<b>ELECTRICAL RATINGS</b>			
Power Supply Voltage (Motor Driver) Normal Operation (Steady-State) Transient Conditions <sup>(3)</sup>	$V_{M(SS)}$ $V_{M(PK)}$	-0.3 to 6.0 -0.3 to 6.5	V
Logic Supply Voltage	$V_{DD}$	6.0	V
Input Pin Voltage	$V_{IN}$	-0.3 to $V_{DD} + 0.3$	V
Driver Output Current (Continuous) <sup>(4)</sup>	$I_O$	400	mA
Driver Output Current (Peak) <sup>(5)</sup>	$I_{OPK}$	800	mA
ESD Voltage <sup>(6)</sup> Human Body Model Machine Model	$V_{ESD1}$ $V_{ESD2}$	$\pm 2000$ $\pm 200$	V
<b>TEMPERATURE RATINGS</b>			
Storage Temperature	$T_{STG}$	-40 to 150	°C
Operating Temperature Ambient	$T_A$	-20 to 85	°C
Operating Junction Temperature	$T_J$	150 maximum	°C
Thermal Resistance (Junction-to-Ambient) Single-Layer PCB Mounting <sup>(9)</sup> Multi-Layer PCB (2S2P) Mounting <sup>(10)</sup>	$R_{\theta JA}$ $R_{\theta JMA}$	169 47	°C/W
Pin Soldering Temperature <sup>(7), (8)</sup>	$T_{PPRT}$	Note 8	°C

**Notes**

- Transient condition within 500 ms.
- Continuous output current must not be exceeded and at operating junction temperature below 150 °C.
- Peak time is for 10 ms pulse width at 200 ms intervals.
- ESD testing is performed in accordance with the Human Body Model ( $C_{ZAP}=100$  pF,  $R_{ZAP}=1500$   $\Omega$ ), **and** the Machine Model ( $C_{ZAP}=200$  pF,  $R_{ZAP}=0$   $\Omega$ ).
- Pin soldering temperature limit is for 10 seconds maximum duration. Not designed for immersion soldering. Exceeding these limits may cause a malfunction or permanent damage to the device.
- Freescle's Package Reflow capability meets Pb-free requirements for JEDEC standard J-STD-020C. For Peak Package Reflow Temperature and Moisture Sensitivity Levels (MSL), Go to [www.freescale.com](http://www.freescale.com), search by part number [e.g. remove prefixes/suffixes and enter the core ID to view all orderable parts (i.e. MC33xxx enter 33xxx), and review parametrics.
- For cases using SEMI G38-87, JEDEC JESD51-2, JESD51-3, JESD51-5, single layer PCB mounting without thermal vias.
- For cases using SEMI JEDEC JESD51-6, JESD51-5, JESD51-7, 2S2P PCB mounting with 4 thermal vias.

## STATIC ELECTRICAL CHARACTERISTICS

**Table 3. Static Electrical Characteristics**

Characteristics noted under conditions  $T_A = 25\text{ }^\circ\text{C}$ ,  $V_{DD} = V_M = 3.0\text{ V}$ , unless otherwise noted. Typical values noted reflect the approximate parameter means at  $T_A = 25\text{ }^\circ\text{C}$  under nominal conditions unless otherwise noted.

Characteristic	Symbol	Min	Typ	Max	Unit
<b>POWER INPUT (VDD, PSAVE)</b>					
Supply Voltage Range					V
Motor Driver Supply Voltage	$V_M$	2.7	3.0	5.5	
Logic Supply Voltage	$V_{DD}$	2.7	3.0	5.5	
Standby Power Supply Current <sup>(11)</sup>					$\mu\text{A}$
$V_M = 3.0\text{ V}$	$I_{VMSTBY}$	–	–	1.0	
$V_{DD} = 3.0\text{ V}$	$I_{VDDSTBY}$	–	–	1.0	
Operating Power Supply Current <sup>(12)</sup>					$\mu\text{A}$
$V_{DD} = 3.0\text{ V}$	$I_C$	–	40	100	
Logic Input Function					
High-Level Input Voltage	$V_{IH}$	$V_{DD} 0.7$	–	–	V
Low-Level Input Voltage	$V_{IL}$	–	–	$V_{DD} 0.3$	V
High-Level Input Current	$I_{IH}$	–	–	1.0	$\mu\text{A}$
Low-Level Input Current	$I_{IL}$	-1.0	–	–	$\mu\text{A}$
PSAVE Pin Low Level Input Current <sup>(13)</sup>	$I_{IL}$	–	-30	-60	$\mu\text{A}$
Driver Output ON Resistance <sup>(14)</sup>	$R_{DS(ON)}$	–	1.0	1.5	$\Omega$
Low Voltage Shutdown Detection Voltage <sup>(15)</sup>	$V_{DDEET}$	1.5	2.0	2.5	V

**Notes**

- Power SAVE mode.
- $I_C$  is the sum of the current of  $V_{DD}$  monitor block “Low Voltage Detection Module” and the PSAVE pull-up resistor at  $f_{IN} = 200\text{ kHz}$ .
- $V_{DD} = 3.0\text{ V}$ .
- $R_{SOURCE} + R_{SINK}$  at  $I_O = 375\text{ mA}$ .
- Detection voltage is defined as when the output becomes high impedance after  $V_{DD}$  voltage falls and when  $V_M = 5.5\text{ V}$ .

## DYNAMIC ELECTRICAL CHARACTERISTICS

**Table 4. Dynamic Electrical Characteristics**

Characteristics noted under conditions  $T_A = 25\text{ }^\circ\text{C}$ ,  $V_{DD} = V_M = 3.0\text{ V}$ , unless otherwise noted. Typical values noted reflect the approximate parameter means at  $T_A = 25\text{ }^\circ\text{C}$  under nominal conditions unless otherwise noted.

Characteristic	Symbol	Min	Typ	Max	Unit
<b>INPUT</b>					
Pulse Input Frequency	$f_{IN}$	–	–	200	kHz
Input Pulse Rise Time <sup>(16)</sup>	$t_R$	–	–	1.0 (17)	$\mu\text{s}$
Input Pulse Fall Time <sup>(18)</sup>	$t_F$	–	–	1.0 (17)	$\mu\text{s}$
<b>OUTPUT</b>					
Output Propagation Delay Time <sup>(19)</sup>					$\mu\text{s}$
Turn-ON Time	$t_{PLH}$	–	0.2	0.5	
Turn-OFF Time	$t_{PHL}$	–	0.1	0.5	
Low-Voltage Detection Time	$t_{VDDDET}$	–	0.02	1.0	ms

**Notes**

16. Time is defined between 10% and 90%.
17. That is, the input waveform slope must be steeper than this.
18. Time is defined between 90% and 10%.
19.  $R_L = 6.8\ \Omega$ . Slew time, rise time, and fall times are between 10% and 90% of output low and high levels with respect to the 50% level of the input.

## TIMING DIAGRAMS

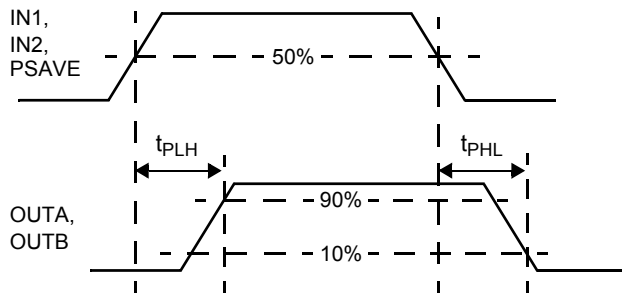
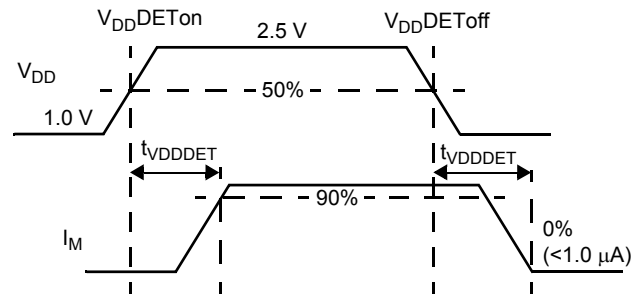

 Figure 4.  $t_{PLH}$  and  $t_{PHL}$  Timing

Figure 5. Low-Voltage Detection Timing

Table 5. Truth Table

INPUT			OUTPUT		$V_{DDDET}^{(21)}$
PSAVE <sup>(19)</sup>	IN1A IN2A	IN1B IN2B	OUT1A OUT2A	OUT1B OUT2B	
L	L	L	L	L	Enabled
L	H	L	H	L	Enabled
L	L	H	L	H	Enabled
L	H	H	Z	Z	Enabled
H	X	X	Z	Z	Disabled

H : High  
 L : Low  
 Z : High-impedance  
 X : Don't care

## Notes

20. Pin 13 (PSAVE) is pulled up by an internal resistor.
21. When  $V_{DD}$  is lower than  $V_{DDDET}$  while  $V_M$  is applied, output becomes "Z" (high-impedance); however, when PSAVE = "H", the low voltage shutdown detection circuit is disabled.

## FUNCTIONAL DESCRIPTION

### INTRODUCTION

The 17C724 is a monolithic dual H-Bridge that is ideal in portable electronic applications to control bipolar step motors and brush DC motors, such as those used in camera lens and shutters. The 17C724 can operate efficiently with supply voltages as low as 2.7 V to as high as 5.5 V, and provide continuous motor drive currents of 0.4 A while handling peak currents up to 0.8 A. It is easily interfaced to low cost MCUs via parallel 3.0 V or 5.0 V compatible logic. The device can be pulse width modulated (PWM'ed) at up to 200 kHz.

The 17C724 can drive two motors simultaneously (see [Figure 6](#)), or it can drive one bipolar step motor as shown in the simplified application diagram on [page 1](#). Dual channel

parallel drive is also possible if higher current drive is desired (0.8 A). Two-motor operation is accomplished by hooking one motor between OUT1A and OUT1B, and the other motor between OUT2A and OUT2B.

This IC has a built-in shoot-through current protection circuit and undervoltage detector to avoid malfunction. It also allows for power-conserving Sleep mode by the setting of the PSAVE pin (refer to [Table 5, Truth Table, page 7](#)).

The device features four operating modes: forward, reverse, brake, and tri-stated (high-impedance).

### FUNCTIONAL PIN DESCRIPTION

#### LOGIC CIRCUIT POWER SUPPLY (VDD)

The VDD pin carries the power source connection to the control (logic) circuit, and its input range is between 2.7 V to 5.5 V (3.0 V and 5.0 V compatible). V<sub>DD</sub> has an undervoltage threshold. If the supply voltage to V<sub>DD</sub> drops below 2.0 V (typical), then all the output of H-Bridges (OUT1A, OUT1B, OUT2A, OUT2B) will become open (high impedance = Z). When the supply voltage returns to a level that is above the threshold voltage the H-Bridge outputs automatically resume normal operation according to the established condition of the input pins.

#### LOGIC INPUT CONTROL (IN1A, IN1B, IN2A, AND IN2B)

These logic input pins control each H-Bridge output. For example, IN1A logic HIGH = OUT1A HIGH; likewise, IN1B logic HIGH = OUT1B HIGH. If both A and B inputs are HIGH, then both A and B outputs are Z (refer to [Table 5, Truth Table, page 7](#)).

#### INPUT ENABLE CONTROL (PSAVE)

The PSAVE input controls the functioning of the power output stages (the H-Bridges). When it is set logic LOW, the output stages are enabled and the H-Bridges function normally. When it is set logic HIGH, the output stages are

disabled and all the outputs are opened (high impedance). In this mode, the built-in low voltage detection circuit is disabled.

#### H-BRIDGE OUTPUT (OUT1A, OUT1B, OUT2A, AND OUT2B)

These pins are the outputs of the power MOSFET H-Bridges. OUT1 is from H-Bridge Channel 1, and OUT2 from H-Bridge Channel 2. These pins will typically connect to an external load (step motor or brush DC motors).

#### MOTOR DRIVER POWER SUPPLY (VM1 AND VM2)

VM1 and VM2 carries the main supply voltage and current into the power sections (the H-Bridges) of the IC. Both of these pins are connected internally but they must be connected together on the printed circuit board with as short as possible traces. The input range is 2.7 V to 5.5 V.

#### POWER GROUND (PGND1 AND PGND2)

These two are the power ground pins that connect to the power ground of the H-Bridges. The power grounds are for higher current handling capability from loads and they must be connected together on the PCB.

#### LOGIC GROUND (LGND)

LGND is the logic ground pin and its current handling level is lower than the PGND.

## TYPICAL APPLICATIONS

Figure 6 shows a typical application for the 17C724.

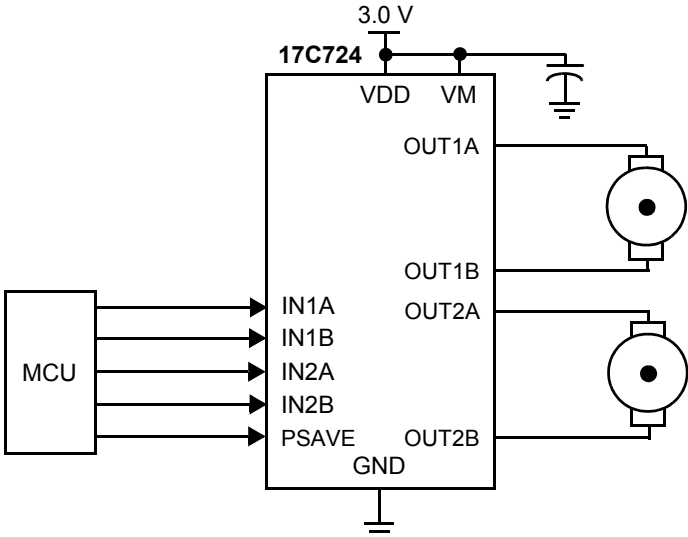

Figure 6. 17C724 Typical Application Diagram

### CEMF SNUBBING TECHNIQUES

Care must be taken to protect the IC from potentially damaging CEMF spikes induced when commutating currents in inductive loads. Typical practice is to provide snubbing of voltage transients by placing a zener or capacitor at the supply pin (VM) (see Figure 7).

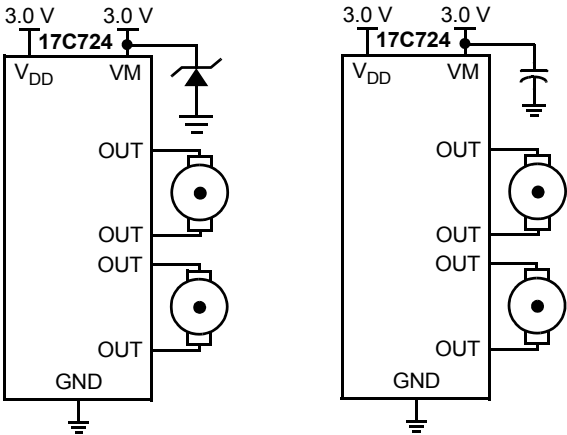

Figure 7. CEMF Snubbing Techniques

### PCB LAYOUT

When designing the printed circuit board (PCB), connect sufficient capacitance between power supply and ground pins to ensure proper filtering from transients. For all high-current paths, use wide copper traces and shortest possible distance.

### APPLICATION NOTES

Although VM1 and VM2 are connected internally, they must be connected externally to attain sufficient power distribution.

Take precautions to guard against electrostatic discharge when handling the device, especially when mounting and demounting the device to a PCB.

## PACKAGING

### PACKAGE DIMENSIONS

Package dimensions are provided in package drawings. To find the most current package outline drawing, go to [www.freescale.com](http://www.freescale.com) and perform a keyword search for the drawing's document number.

**Table 6.**

Package	Suffix	Package Outline Drawing Number
16-PIN QFN	EP	98ASA00741D

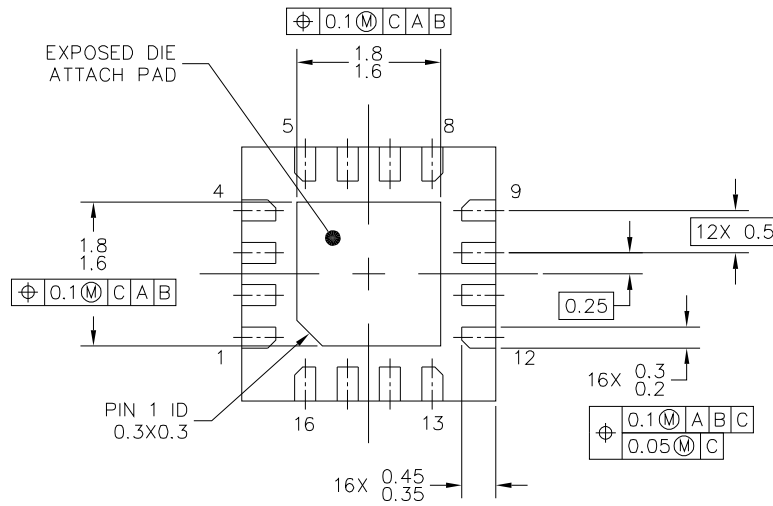
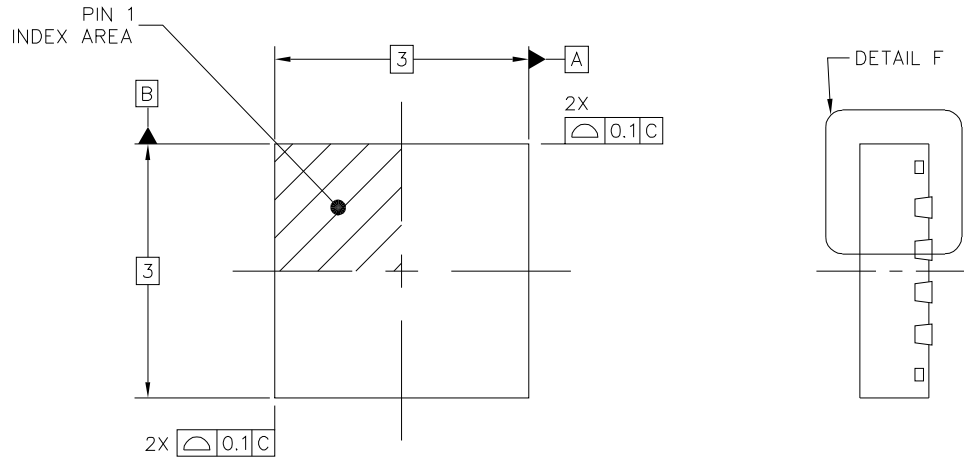

© FREESCALE SEMICONDUCTOR, INC. ALL RIGHTS RESERVED.	MECHANICAL OUTLINE	PRINT VERSION NOT TO SCALE
TITLE: QFN, THERMALLY ENHANCED, 3 X 3 X 0.85, 0.5 PITCH, 16 TERMINAL	DOCUMENT NO: 98ASA00741D	REV: 0
	STANDARD: NON-JEDEC	
	16 MAY 2014	

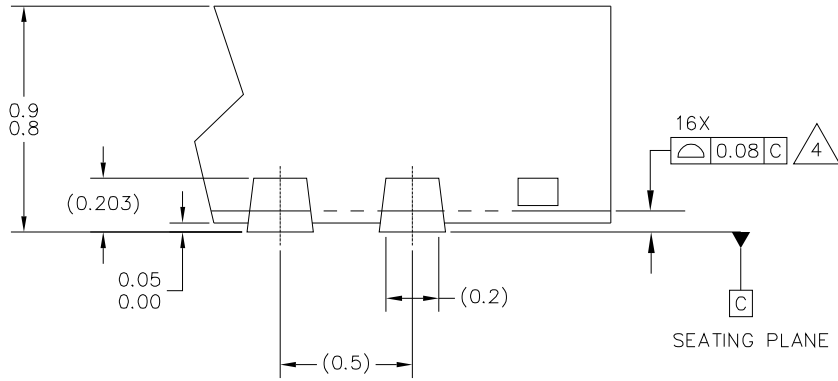

DETAIL F  
VIEW ROTATED 90°CW

© FREESCALE SEMICONDUCTOR, INC. ALL RIGHTS RESERVED.	MECHANICAL OUTLINE	PRINT VERSION NOT TO SCALE	
TITLE: QFN, THERMALLY ENHANCED, 3 X 3 X 0.85, 0.5 PITCH, 16 TERMINAL		DOCUMENT NO: 98ASA00741D	REV: 0
		STANDARD: NON-JEDEC	
		16 MAY 2014	

NOTES:

1. ALL DIMENSIONS ARE IN MILLIMETERS.
2. DIMENSIONING AND TOLERANCING PER ASME Y14.5M-1994.
3. THIS IS A NON-JEDEC REGISTERED PACKAGE.
4.  COPLANARITY APPLIES TO LEADS AND DIE ATTACH FLAG.
5. MIN. METAL GAP SHOULD BE 0.2 MM.

© FREESCALE SEMICONDUCTOR, INC. ALL RIGHTS RESERVED.	MECHANICAL OUTLINE	PRINT VERSION NOT TO SCALE	
TITLE: QFN, THERMALLY ENHANCED, 3 X 3 X 0.85, 0.5 PITCH, 16 TERMINAL		DOCUMENT NO: 98ASA00741D	REV: 0
		STANDARD: NON-JEDEC	
		16 MAY 2014	

## REVISION HISTORY

REVISION	DATE	DESCRIPTION OF CHANGES
2.0	2005	<ul style="list-style-type: none"> <li>• Initial Release</li> </ul>
	12/2013	<ul style="list-style-type: none"> <li>• No technical changes</li> <li>• Revised back page</li> <li>• Updated document properties</li> </ul>
3.0	9/2014	<ul style="list-style-type: none"> <li>• Updated the case outline as per Cu wire PCN 16443.</li> <li>• The change of package case outline is required to support the new assembly process.</li> </ul>



**How to Reach Us:**

**Home Page:**  
[freescale.com](http://freescale.com)

**Web Support:**  
[freescale.com/support](http://freescale.com/support)

Information in this document is provided solely to enable system and software implementers to use Freescale products. There are no express or implied copyright licenses granted hereunder to design or fabricate any integrated circuits based on the information in this document.

Freescale reserves the right to make changes without further notice to any products herein. Freescale makes no warranty, representation, or guarantee regarding the suitability of its products for any particular purpose, nor does Freescale assume any liability arising out of the application or use of any product or circuit, and specifically disclaims any and all liability, including without limitation consequential or incidental damages.

“Typical” parameters that may be provided in Freescale data sheets and/or specifications can and do vary in different applications, and actual performance may vary over time. All operating parameters, including “typicals,” must be validated for each customer application by customer’s technical experts. Freescale does not convey any license under its patent rights nor the rights of others. Freescale sells products pursuant to standard terms and conditions of sale, which can be found at the following address: [freescale.com/SalesTermsandConditions](http://freescale.com/SalesTermsandConditions).

Freescale and the Freescale logo are trademarks of Freescale Semiconductor, Inc., Reg. U.S. Pat. & Tm. Off. SMARTMOS is a trademark of Freescale Semiconductor, Inc. All other product or service names are the property of their respective owners.

© 2014 Freescale Semiconductor, Inc.

Document Number: MPC17C724  
Rev 3.0  
9/2014

## Looking for pricing, stock, or lifecycle information?

Click below to explore more details on WIN SOURCE:

- ⊖ [View MPC17C724EPR2 on WIN SOURCE](#)
- ⊖ [Freescale Semiconductor - NXP Information](#)

## Optimize Your Supply Chain with WIN SOURCE Solutions

- ✓ Global Sourcing Solution
- ✓ Obsolete Management
- ✓ Cost Control Management
- ✓ Shortage Management
- ✓ Alternative Solution
- ✓ Excess Inventory Management