



**THE DATASHEET OF
MP2610ER-LF-Z**



DESCRIPTION

The MP2610 is a monolithic switching charger for 1 or 2 cells Li-Ion battery packs with a built-in internal power MOSFET. It achieves up to 2A charge current with current mode control for fast loop response and easy compensation. The charge current can be programmed by sensing the current through an accurate sense resistor.

MP2610 regulates the charge current and charger voltage using two control loops to realize high accuracy CC charge and CV charge.

Fault condition protection includes cycle - by - cycle current limiting and thermal shutdown. Other safety features include battery temperature monitoring, charge status indication, and programmable timer to cease the charging cycle.

The MP2610 requires a minimum number of readily available standard external components.

The MP2610 is available in 4mm×4mm 16-pin QFN package.

FEATURES

- Charges 1/2 - cell Li-Ion battery packs
- Wide 5V to 24V Operating Input Range
- Up to 2A Programmable Charging Current
- $\pm 0.75\%$ V_{BATT} Accuracy
- 0.2Ω Internal Power MOSFET Switch
- Up to 90% Efficiency
- Fixed 1.1MHz Frequency
- Preconditioning for Fully Depleted Batteries
- Charging Operation Indicator
- Input Supply and Battery Fault Indicator
- Thermal Shutdown
- Cycle-by-Cycle Over Current Protection
- Battery Temperature Monitor and Protection

APPLICATIONS

- Distributed Power Systems
- Chargers for 1-Cell or 2-Cell Li-Ion Batteries
- Smart Phones
- Portable DVD Player

"MPS" and "The Future of Analog IC Technology" are Registered Trademarks of Monolithic Power Systems, Inc.

TYPICAL APPLICATION

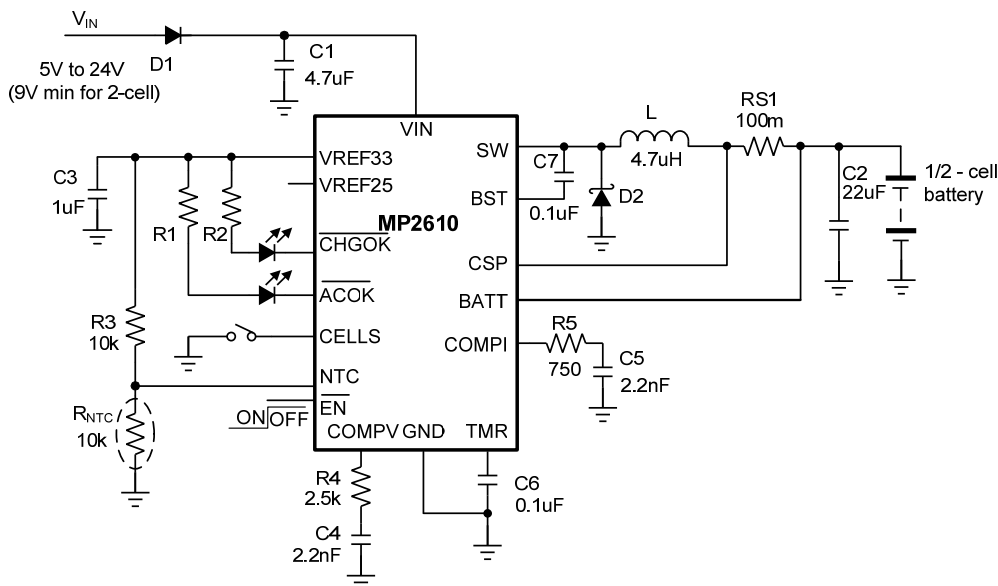

Figure 1—Standalone Switching Charger

ORDERING INFORMATION

Part Number*	Package	Top Marking	Free Air Temperature (T _A)
MP2610ER	4mm×4mm QFN16	2610ER	-20°C to +85°C

* For Tape & Reel, add suffix-z (e.g. MP2610ER-Z);
For RoHS Compliant packaging, add suffix-LF (e.g. MP2610ER-LF-Z)

PACKAGE REFERENCE

TOP VIEW

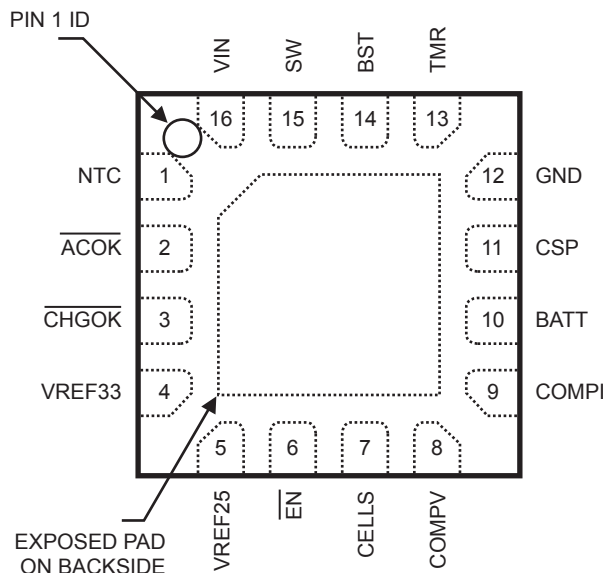

ABSOLUTE MAXIMUM RATINGS ⁽¹⁾

Supply Voltage V _{IN}	26V
V _{SW}	-0.3V to V _{IN} + 0.3V
V _{BST}	V _{SW} + 6V
V _{CSP} , V _{BATT} ,	-0.3V to +18V
All Other Pins	-0.3V to +6V
Continuous Power Dissipation (T _A =+25°C) ⁽²⁾	2.7W
Junction Temperature	150°C
Lead Temperature	260°C
Storage Temperature	-65°C to +150°C

Recommended Operating Conditions ⁽³⁾

Supply Voltage V _{IN}	5V to 24V
Operating Junct.Temp(T _J)	-20°C to +125°C

Thermal Resistance ⁽⁴⁾	θ_{JA}	θ_{JC}
4mm×4mm QFN16	46	10... °C/W

Notes:

- 1) Exceeding these ratings may damage the device.
- 2) The maximum allowable power dissipation is a function of the maximum junction temperature T_J(MAX), the junction-to-ambient thermal resistance θ_{JA} , and the ambient temperature T_A. The maximum allowable continuous power dissipation at any ambient temperature is calculated by P_D(MAX)=(T_J(MAX)-T_A)/ θ_{JA} . Exceeding the maximum allowable power dissipation will cause excessive die temperature, and the regulator will go into thermal shutdown. Internal thermal shutdown circuitry protects the device from permanent damage.
- 3) The device is not guaranteed to function outside of its operating conditions.
- 4) Measured on JESD51-7 4-layer board.

ELECTRICAL CHARACTERISTICS

$V_{IN} = 19V$, $T_A = +25^\circ C$, CELLS=0V, unless otherwise noted.

Parameters	Symbol	Condition	Min	Typ	Max	Units
Terminal Battery Voltage	V_{BATT}	CELLS=0V	4.168	4.2	4.232	V
		CELLS= VREF33	8.337	8.4	8.463	
CSP, BATT Current	I_{CSP}, I_{BATT}	Charging disabled			1	μA
Switch On Resistance	$R_{DS(ON)}$			0.2		Ω
Switch Leakage		$\overline{EN} = 4V, V_{SW} = 0V$		0	10	μA
Peak Current Limit		CC Mode		3.8		A
		Trickle Mode		1.75		A
CC current	I_{CC}	RS1= 100m Ω	1.8	2.0	2.2	A
Trickle charge current	$I_{TRICKLE}$			10%		I_{CC}
Trickle charge voltage threshold		CELLS=0V		2.8		V
		CELLS=3.3V		5.6		V
Trickle charge hysteresis				350		mV
Termination current threshold	I_{BF}		5%	10%	15%	I_{CC}
Oscillator Frequency	f_{SW}	CELLS=0V, $V_{BATT} = 4.5V$		1.1		MHz
Fold-back Frequency		$V_{BATT} = 0V$		350		kHz
Maximum Duty Cycle			87			%
Maximum current Sense Voltage (CSP to BATT)	V_{SENSE}		170	200	230	mV
Minimum On Time	t_{ON}	CELLS=0V, $V_{BATT} = 5V$		100		ns
Under Voltage Lockout Threshold Rising			3	3.2	3.4	V
Under Voltage Lockout Threshold Hysteresis				200		mV
Open-drain sink current (\overline{ACOK}), (\overline{CHGOK})		$V_{DRAIN} = 0.3V$	5			mA
Dead-battery indication		Stay at trickle mode		30		min
Termination delay		Time after I_{BF} reached		1		min
Recharge threshold at V_{BATT}	V_{RECHG}			4.0		V/cell
Recharge Hysteresis				100		mV/Cell
NTC Low Temp Rising Threshold		$R_{NTC} = NCP18XH103 (0^\circ C)$		73		%of VREF33
		Recovery Hysteresis		3		
NTC High Temp Falling Threshold		$R_{NTC} = NCP18XH103 (50^\circ C)$		30		%of VREF33
		Recovery Hysteresis		2		
VIN min head-room (reverse blocking)		$V_{IN} - V_{BATT}$		180		mV

ELECTRICAL CHARACTERISTICS *(continued)*

$V_{IN} = 19V$, $T_A = +25^{\circ}C$, $CELLS=0V$, unless otherwise noted.

Parameters	Symbol	Condition	Min	Typ	Max	Units
Supply Current (Shutdown)		$\overline{EN}=4V$		0.16		mA
		$\overline{EN}=4V$, Consider V_{REF33} pin output current. $R_3=10k$, $R_{NTC}=10k$		0.32		mA
Supply Current (Quiescent)		$\overline{EN}=0V$, $CELLS=0V$			2.0	mA
\overline{EN} Input Low Voltage					0.4	V
\overline{EN} Input High Voltage			1.8			V
\overline{EN} Input Current		$\overline{EN}=4V$		4		μA
		$\overline{EN}=0V$		0.2		
Thermal Shutdown				150		$^{\circ}C$
V_{REF25} output voltage				2.5		V
V_{REF33} output voltage				3.3		V
V_{REF33} load regulation		$I_{LOAD}=0$ to 10mA		30	50	mV

PIN FUNCTIONS

Pin #	Name	Description
1	NTC	Thermistor Input. Connect a resistor from this pin to the pin VREF33 and the Thermistor from this pin to ground.
2	$\overline{\text{ACOK}}$	Valid Input Supply Indicator. A logic LOW on this pin indicates the presence of a valid input supply.
3	$\overline{\text{CHGOK}}$	Charging Completion Indicator. A logic LOW indicates charging operation. The pin will become an open drain once the charging is completed or suspended.
4	VREF33	Internal linear regulator 3.3V reference output. Bypass to GND with a 1 μ F ceramic capacitor.
5	VREF25	Internal linear regulator 2.5V reference output.
6	$\overline{\text{EN}}$	On/Off Control Input.
7	CELLS	Command Input for the Number of Li-Ion Cells. Connect this pin to VREF33 for 2-cell operation or ground the pin for 1-cell operation. Do not leave this pin float.
8	COMPV	V-LOOP Compensation. Connect this pin with a capacitor and a resistor.
9	COMPI	I-LOOP Compensation. Connect this pin with a capacitor and a resistor.
10	BATT	Positive Battery Terminal.
11	CSP	Battery Current Sense Positive Input. Connect a resistor RS1 between CSP and BATT. The full charge current is: $I_{\text{CHG}}(\text{A}) = \frac{200\text{mV}}{\text{RS1}(\text{m}\Omega)}$.
12	GND, Exposed Pad	Ground. This pin is the voltage reference for the regulated output voltage. For this reason care must be taken in its layout. This node should be placed outside of the switching diode (D2) to the input ground path to prevent switching current spikes from inducing voltage noise into the part. Connect exposed pad to ground plane for optional thermal performance.
13	TMR	Set time constant. 0.1 μ A current charges and discharges the external cap.
14	BST	Bootstrap. This capacitor is needed to drive the power switch's gate above the supply voltage. It is connected between SW and BS pins to form a floating supply across the power switch driver.
15	SW	Switch Output.
16	IN	Supply Voltage. The MP2610 operates from a 5V to 24V unregulated input to charge 1~2 cell li-ion battery. Capacitor is needed to prevent large voltage spikes from appearing at the input.

TYPICAL PERFORMANCE CHARACTERISTICS

$V_{IN}=19V$, $C1=4.7\mu F$, $C2=22\mu F$, $L=4.7\mu H$, $RS1=100m\Omega$, Real Battery Load, $T_A=25^\circ C$, unless otherwise noted.

1-Cell Battery Charge Curve

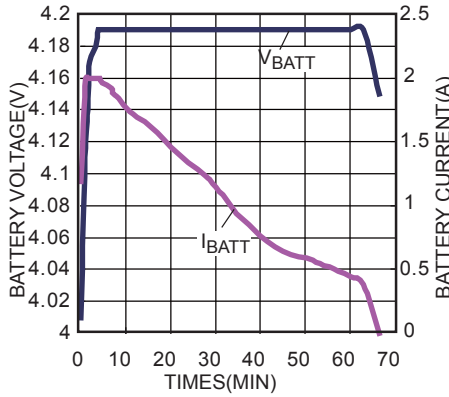

1-cell Charge Current vs. Battery Voltage

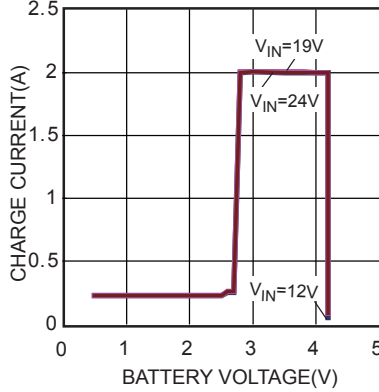

2-Cell Battery Charge Curve

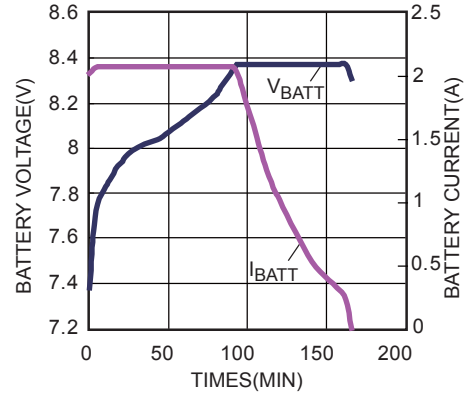

2-cell Charge Current vs. Battery Voltage

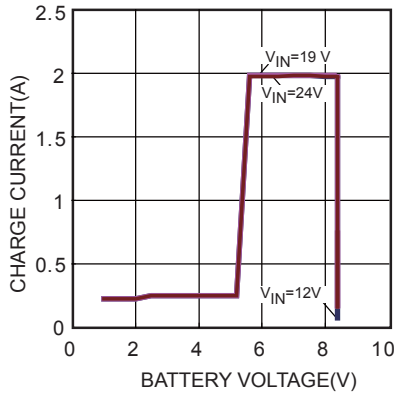

NTC Control Window

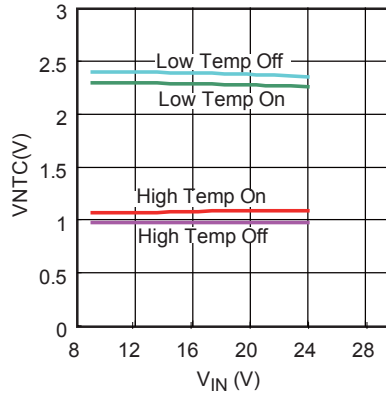

Efficiency vs. I_{CHG}

1-Cell, $V_{BATT}=4.2V$, CC Load

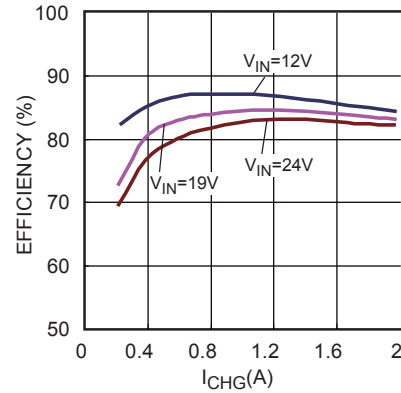

Efficiency vs. V_{CHG}

2-Cell, $V_{BATT}=8.4V$, CC Load

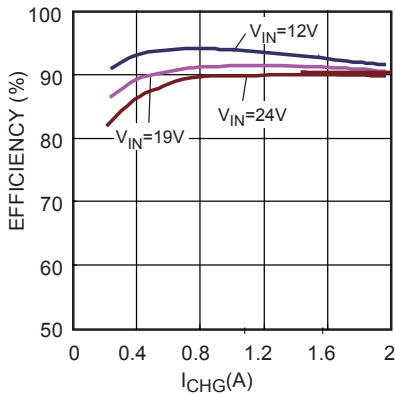

BATT Float Voltage vs. V_{IN}

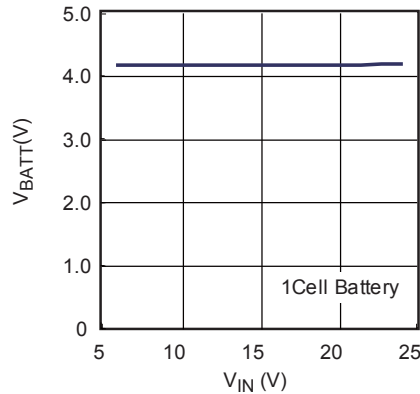

Efficiency vs. V_{CHG}

2-Cell, $V_{BATT}=7.4V$, CC Load

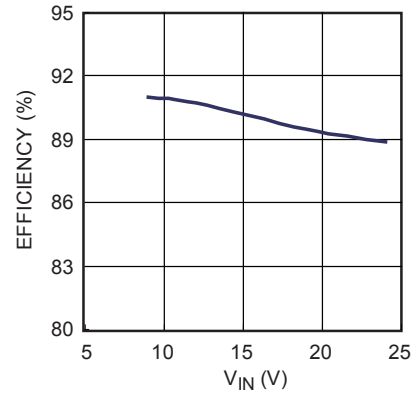

TYPICAL PERFORMANCE CHARACTERISTICS (continued)

$V_{IN}=19V$, $C1=4.7\mu F$, $C2=22\mu F$, $L=4.7\mu H$, $RS1=100m\Omega$, Real Battery Load, $T_A=25^\circ C$, unless otherwise noted.

Steady State Waveform

Trickle Charge
1-Cell, $V_{BATT}=2.5V$, CV Load

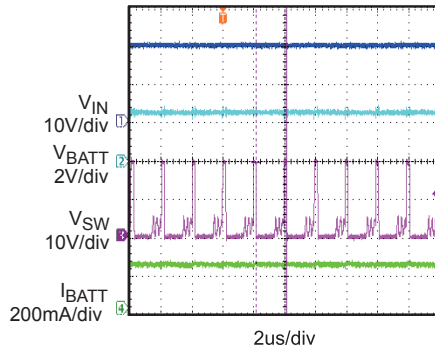

Steady State Waveform

CC Change
1-Cell, $V_{BATT}=3.8V$, CV Load

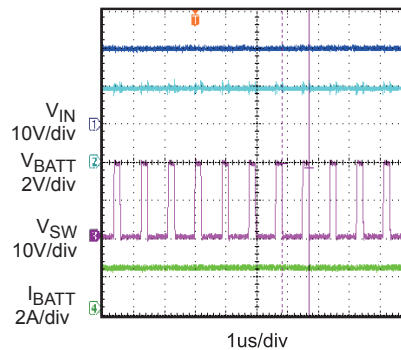

Steady State Waveform

CV Change
1-Cell, $V_{BATT}=4.2V$, CV Load

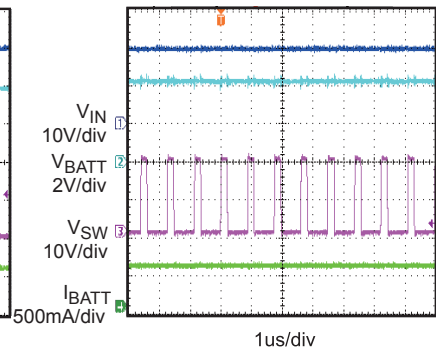

Power On Waveform

1-Cell, $I_{CHG}=2A$, $V_{BATT}=4V$

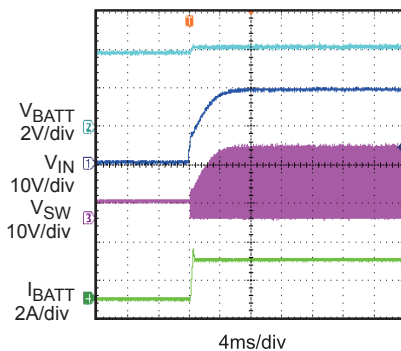

Power Off Waveform

1-Cell, $I_{CHG}=2A$, $V_{BATT}=4V$

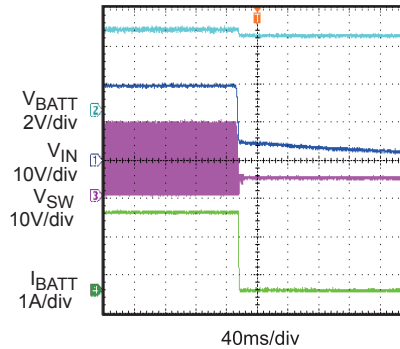

EN On Waveform

1-Cell, $I_{CHG}=2A$, $V_{BATT}=4V$

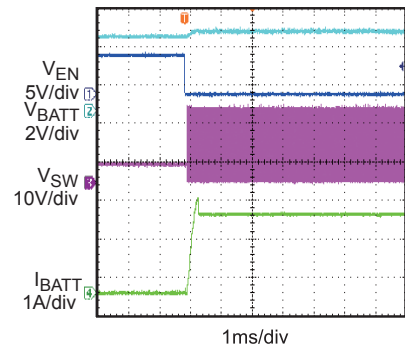

EN Off Waveform

1-Cell, $I_{CHG}=2A$, $V_{BATT}=4V$

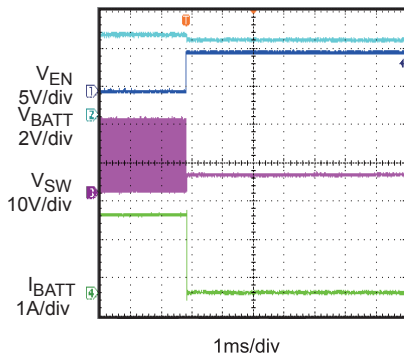

NTC Control

1-Cell, $V_{BATT}=3.8V$, CV Load

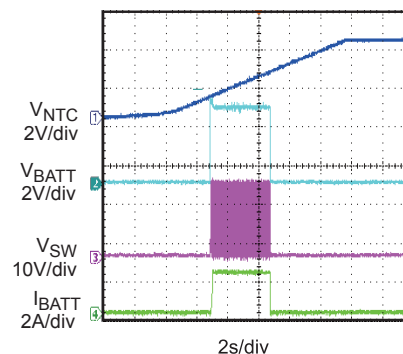

Time Out

1-Cell, $V_{BATT}=3.8V$, CV Load, $C_{TMR}=1nF$

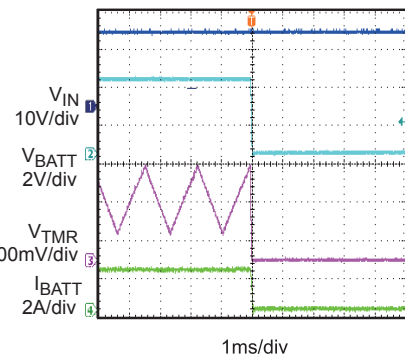

BLOCK DIAGRAM

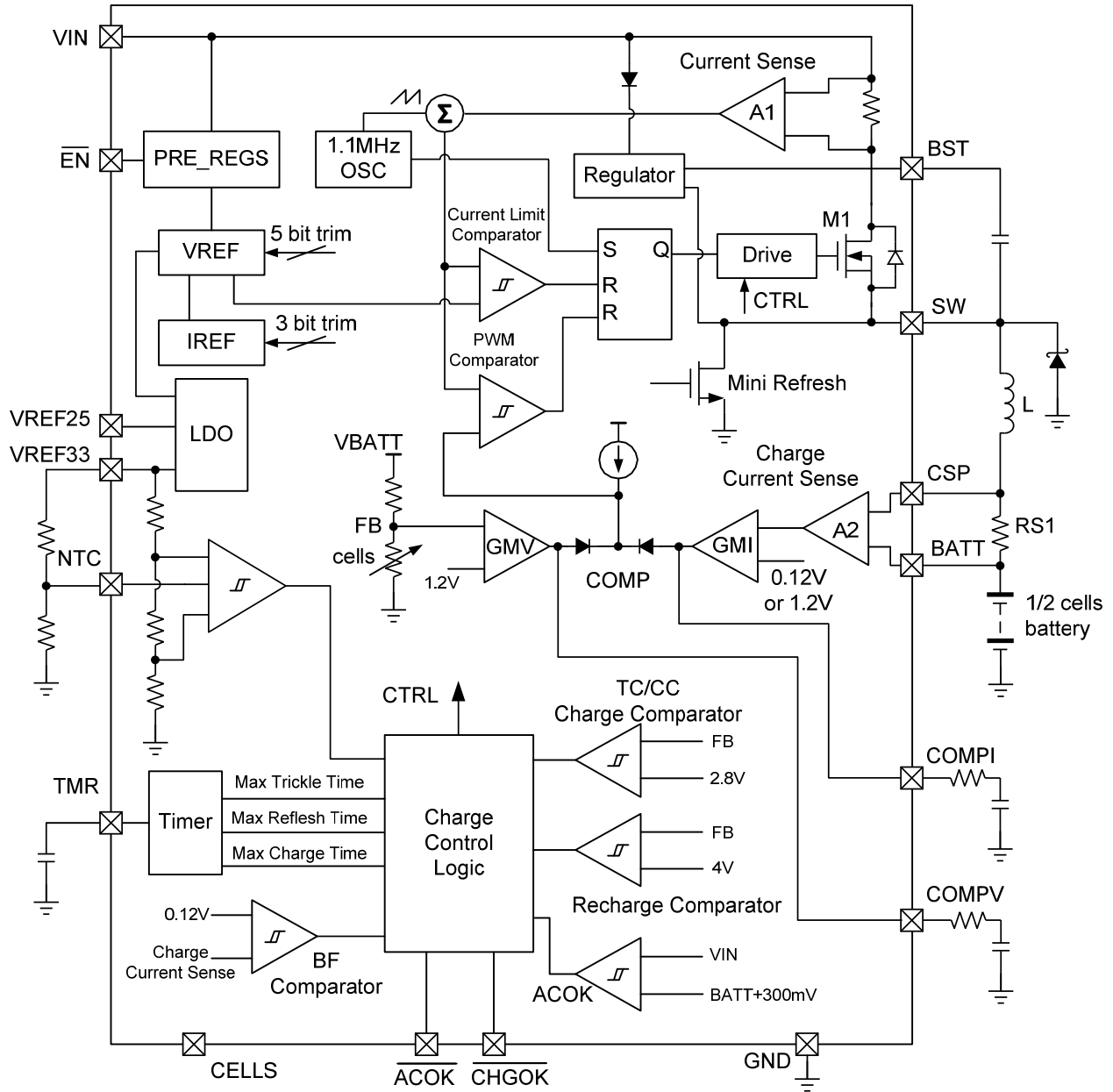

Figure 2—Function Block Diagram

OPERATION

The MP2610 is a peak current mode controlled switching charger for use with Li-Ion batteries.

Figure 2 shows the block diagram. At the beginning of a cycle, M1 is off. The COMP voltage is higher than the current sense result from amplifier A1's output and the PWM comparator's output is low. The rising edge of the 1.1MHz CLK signal sets the RS Flip-Flop. Its output turns on M1 thus connecting the SW pin and inductor to the input supply.

The increasing inductor current is sensed and amplified by the Current Sense Amplifier A1. Ramp compensation is summed to the output of A1 and compared to COMP by the PWM comparator.

When the sum of A1's output and the Slope Compensation signal exceeds the COMP voltage, the RS Flip-Flop is reset and M1 is turned off. The external switching diode D2 then conducts the inductor current.

If the sum of A1's output and the Slope Compensation signal does not exceed the COMP voltage, then the falling edge of the CLK resets the Flip-Flop.

The MP2610 have two internal linear regulators power internal circuit, VREF33 and VREF25. The output of 3.3V reference voltage can also power external circuitry as long as the maximum current (50mA) is not exceeded. A 1µF bypass capacitor is required from VREF33 to GND to ensure stability.

The output of 2.5V reference voltage can not carry any load, and it can only be a voltage reference, like connecting it to the gate of a MOSFET.

In typical application, VREF25 should be float and no capacitor is required. It can only connect to a capacitor which is smaller than 100pF.

Charge Cycle (Mode change: Trickle→ CC→ CV)

The battery current is sensed via RS1 (Figure 2) and amplified by A2. The charge will start in "trickle charging mode" (10% of the RS1 programmed current I_{CC}) until the battery voltage reaches 2.8V/cell. If the charge stays in the

"trickle charging mode till "timer out" condition is triggered, the charger is terminated. Otherwise, the output of A2 is then regulated to the level set by RS1. The charger is operating at "constant current charging mode." The duty cycle of the switcher is determined by the COMPI voltage that is regulated by the amplifier GMI.

When the battery voltage reaches the "constant voltage mode" threshold, the amplifier GMV will regulate the COMP pin, and then the duty cycle. The charger will then operate in "constant voltage mode."

Automatic Recharge

1 minute after the battery charging current drops below the termination threshold, the charger will cease charging and the $\overline{\text{CHGOK}}$ pin becomes an open drain. If for some reason, the battery voltage is lowered to 4.0V/Cell, recharge will automatically kick in.

Charger Status Indication

MP2610 has two open-drain status outputs: $\overline{\text{CHGOK}}$ and $\overline{\text{ACOK}}$. The $\overline{\text{ACOK}}$ pin pulls low when an input voltage is greater than battery voltage 300mV and over the under voltage lockout threshold. $\overline{\text{CHGOK}}$ is used to indicate the status of the charge cycle. Table 1 describes the status of the charge cycle based on the $\overline{\text{CHGOK}}$ and $\overline{\text{ACOK}}$ outputs.

Table 1—Charging Status Indication

$\overline{\text{ACOK}}$	$\overline{\text{CHGOK}}$	Charger status
low	low	In charging
low	high	End of charge
high	high	$V_{in} < UVLO$, thermal shutdown, timer out, $\overline{\text{EN}}$ disable

Timer Operation

MP2610 uses internal timer to terminate the charge if the timer times out. The timer duration is programmed by an external capacitor at the TMR pin.

The trickle mode charge time is:

$$T_{\text{TICKLE_TMR}} = 30\text{mins} \times \frac{C_{\text{TMR}}}{0.1\mu\text{F}}$$

The total charge time is:

$$T_{\text{TOTAL_TMR}} = 3\text{hours} \times \frac{C_{\text{TMR}}}{0.1\mu\text{F}}$$

Negative Thermal Coefficient (NTC) Thermistor

The MP2610 has a built-in NTC resistance window comparator, which allows MP2610 to sense the battery temperature via the thermistor packed internally in the battery pack to ensure a safe operating environment of the battery.

A resistor with appropriate value should be connected from VREF33 to NTC pin and the thermistor is connected from NTC pin to GND. The voltage on NTC pin is determined by the resistor divider whose divide ratio depends on the battery temperature. When the voltage of pin NTC falls out of NTC window range, MP2610 will stop the charging. The charger will restart if the temperature goes back into NTC window range.

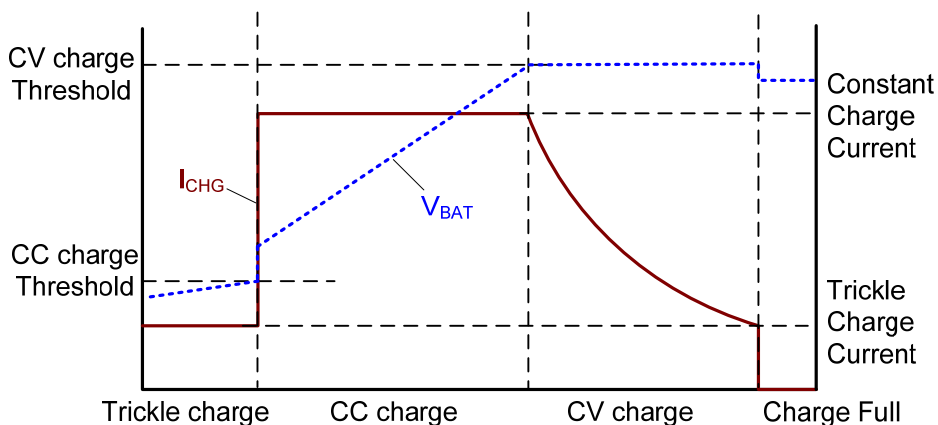

Figure 3—Li-Ion Battery Charge Profile

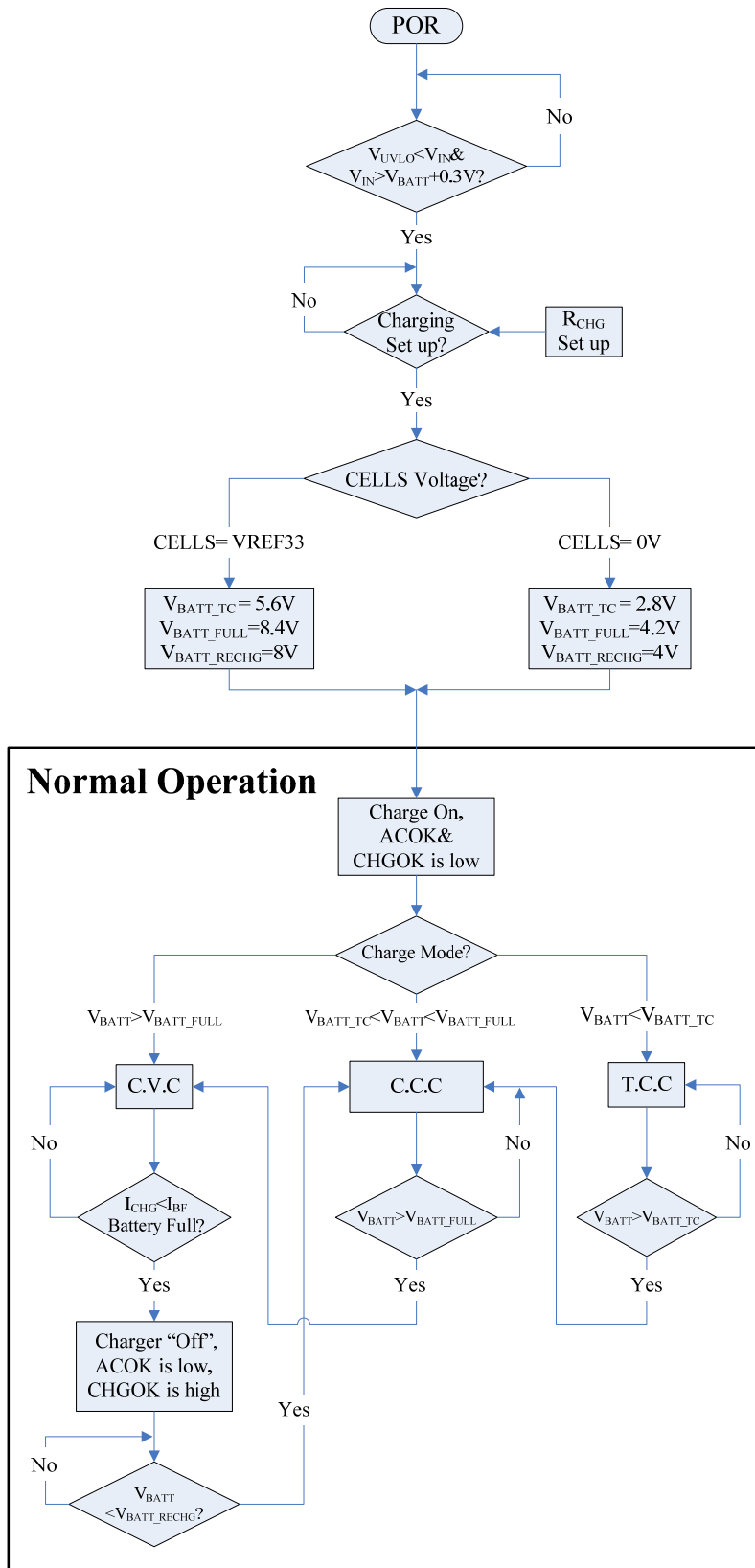

Figure 4— Normal Charging Operation Flow Chart

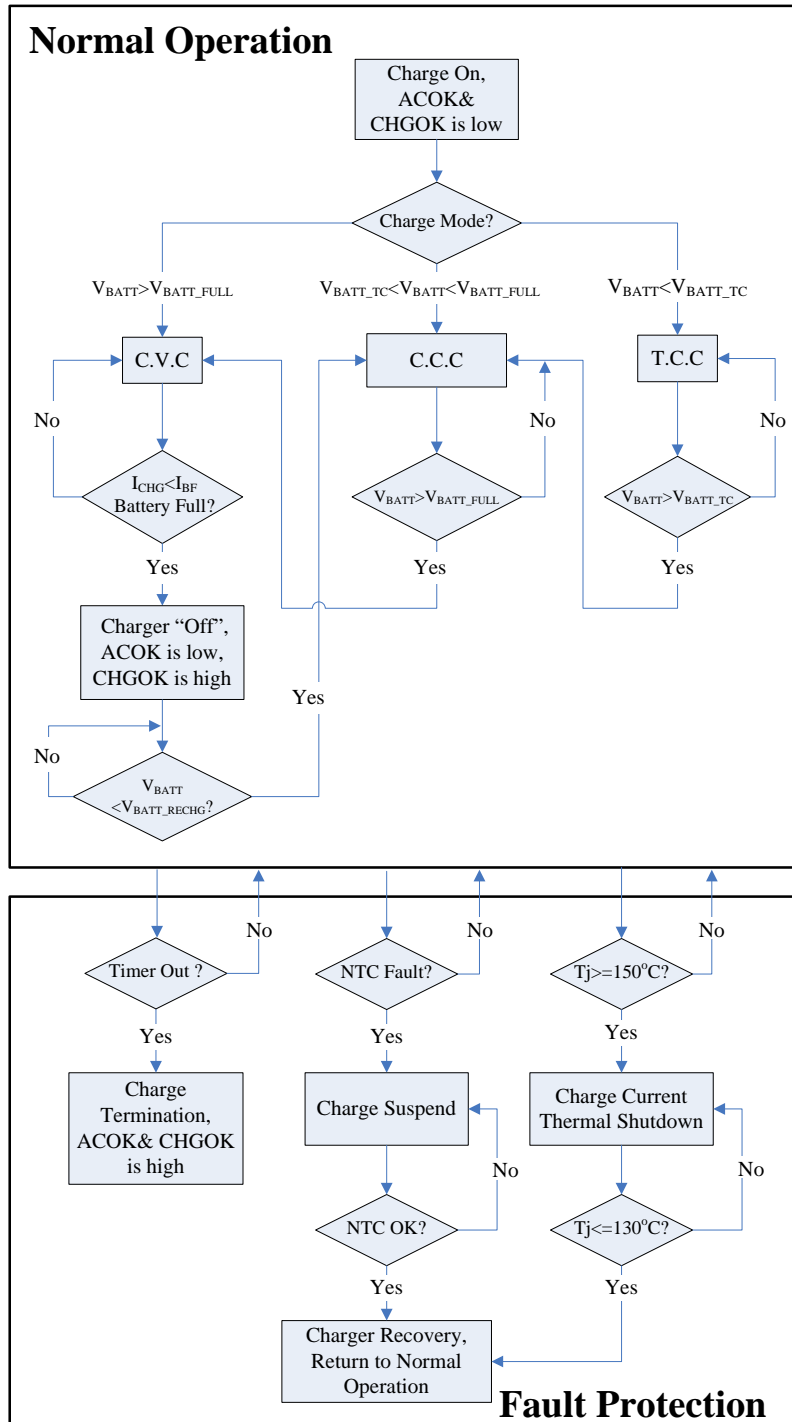

Figure 5— Fault Protection Flow Chart

APPLICATION INFORMATION

Setting the Charge Current

The charge current of MP2610 is set by the sense resistor RS1 (Figure1). The charge current programmable formula is as following:

$$I_{CHG}(A) = \frac{200mV}{RS1(m\Omega)} \quad (1)$$

Table2— I_{CHG} Setting

$I_{CHG}(A)$	RS(m Ω)
2	100
1.5	133
1	200
0.8	250
0.5	400

Selecting the Inductor

A 1 μ H to 10 μ H inductor is recommended for most applications. The inductance value can be derived from the following equation.

$$L = \frac{V_{OUT} \times (V_{IN} - V_{OUT})}{V_{IN} \times \Delta I_L \times f_{OSC}} \quad (2)$$

Where ΔI_L is the inductor ripple current. VOUT is 1/2 Cell battery voltage.

Choose inductor current to be approximately 30% if the maximum charge current, 2A. The maximum inductor peak current is:

$$I_{L(MAX)} = I_{LOAD} + \frac{\Delta I_L}{2} \quad (3)$$

Under light load conditions below 100mA, larger inductance is recommended for improved efficiency.

For optimized efficiency, the inductor DC resistance is recommended to be less than 200m Ω .

NTC Function

As Figure 6 shows, the low temperature threshold and high temperature threshold are preset internally via a resistive divider, which are 73%·VREF33 and 30%·VREF33. For a given NTC thermistor, we can select appropriate R3 and R6 to set the NTC window.

In detail, for the thermistor (NCP18XH103) noted in above electrical characteristic,

At 0°C, $R_{NTC_Cold} = 27.445k\Omega$;

At 50°C, $R_{NTC_Hot} = 4.1601k\Omega$.

Assume that the NTC window is between 0°C and 50°C, the following equations could be derived:

$$\frac{R6//R_{NTC_Cold}}{R3 + R6//R_{NTC_Cold}} = \frac{V_{TH_Low}}{VREF33} = 73\% \quad (4)$$

$$\frac{R6//R_{NTC_Hot}}{R3 + R6//R_{NTC_Hot}} = \frac{V_{TH_High}}{VREF33} = 30\% \quad (5)$$

According to equation (4) and equation (5), we can find that R3 = 9.63k and R6 = 505k.

To be simple in project, making R3=10k and R6 no connect will approximately meet the specification.

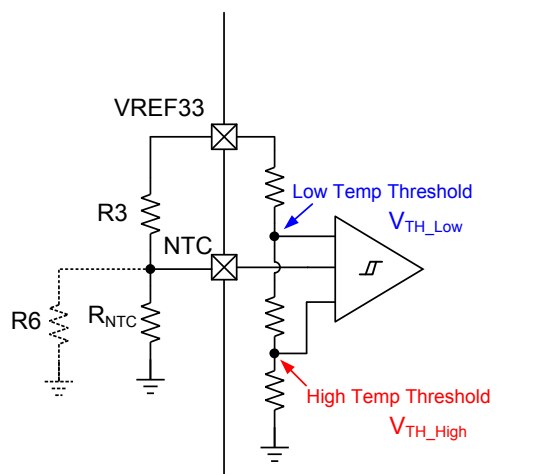

Figure 6— NTC function block

Selecting the Input Capacitor

The input capacitor reduces the surge current drawn from the input and also the switching noise from the device. The input capacitor impedance at the switching frequency should be less than the input source impedance to prevent high frequency switching current passing to the input. Ceramic capacitors with X5R or X7R dielectrics are highly recommended because of their low ESR and small temperature coefficients. For most applications, a 4.7 μ F capacitor is sufficient.

Selecting the Output Capacitor

The output capacitor keeps output voltage ripple small and ensures regulation loop stability. The output capacitor impedance should be low at the switching frequency. Ceramic capacitors with X5R or X7R dielectrics are recommended.

PC Board Layout

The high frequency and high current paths (GND, IN and SW) should be placed to the device with short, direct and wide traces. The input capacitor needs to be as close as possible to the IN and GND pins. The external feedback resistors should be placed next to the FB pin. Keep the switching node SW short and away from the feedback network.

Application for USB Input

When a USB is selected as the power source of the switching charger, the typical application circuit is as figure 7 shows. One PMOS is used instead of the block diode D1 to low down the

voltage drop, and realizing less minimum input to charge a single cell battery full. The charge current is set to be 1A to satisfy turbo USB or 5Vin Wall-Adapter specification requirement and realize the fast charging.

Figure 8 is the typical charging curve. The charge current can't keep constant at the setting value during the operation at the constant current charging mode. It drops down when the maximum duty of the part is hit. Set the charge current lower, the constant current charge duration will be extended. Results illuminates that MP2610 is reasonable for the usual USB input application.

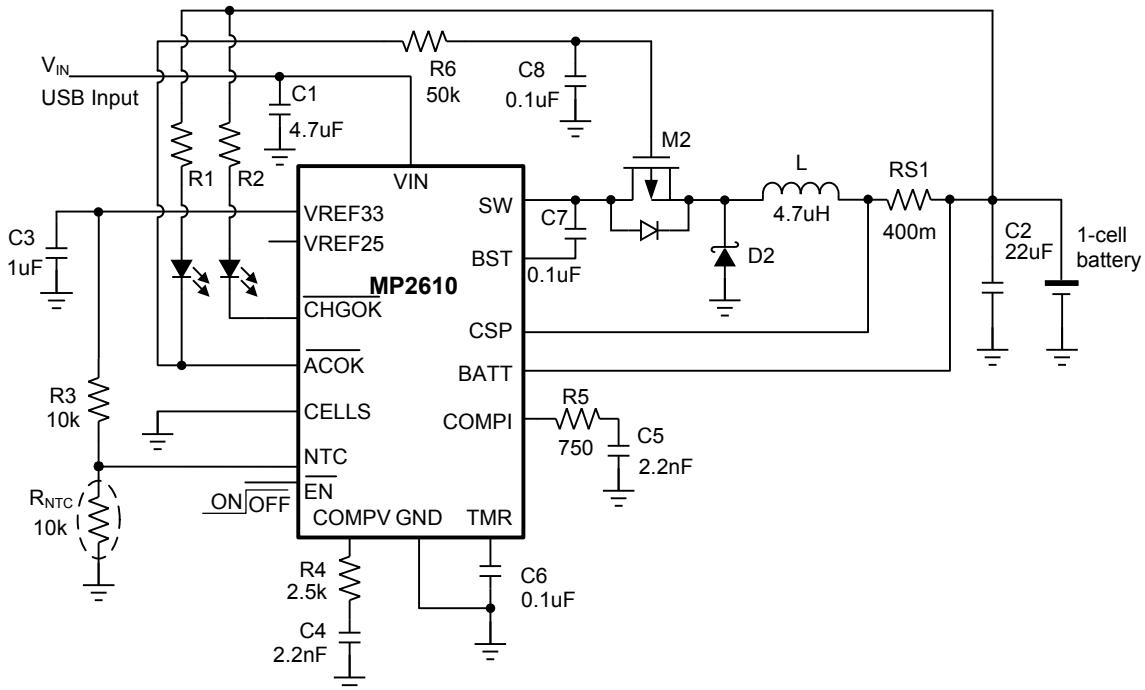

Figure 7— Typical Application Circuit for USB Input

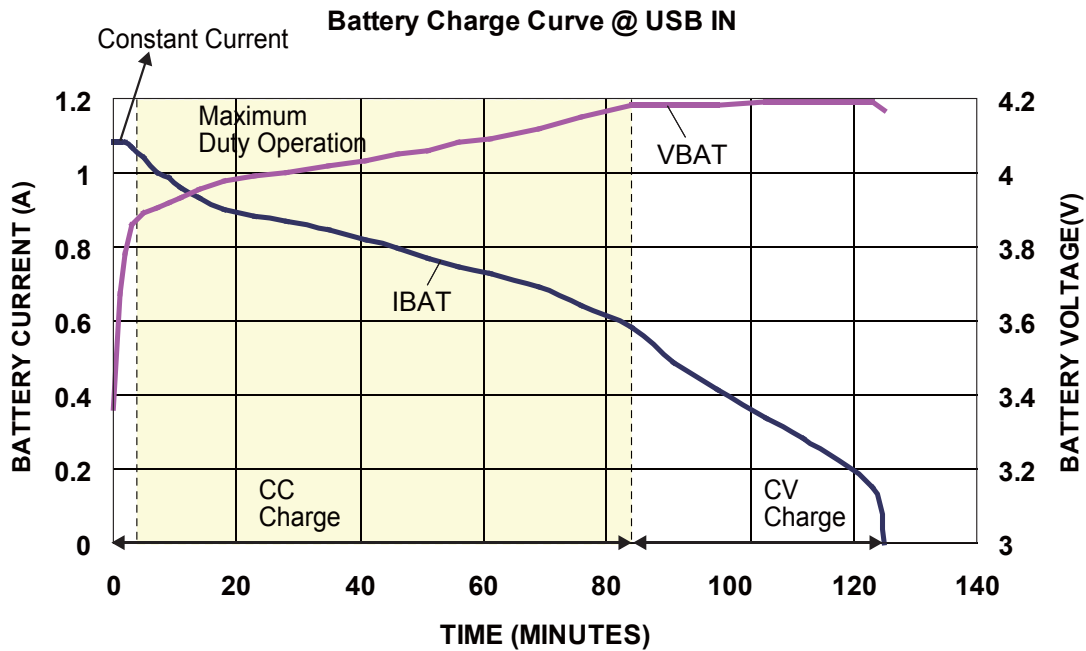
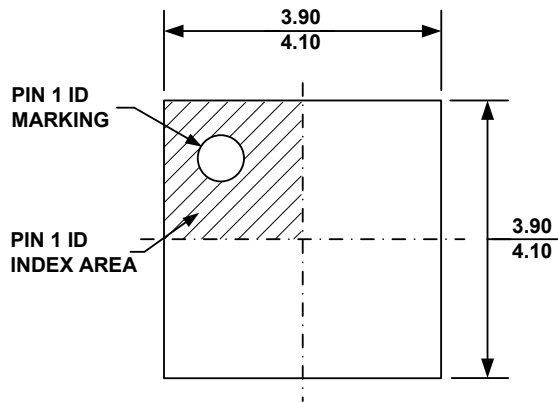

Figure 8— Battery Charge Curve @ USB In

PACKAGE INFORMATION

QFN16 (4mm x 4mm)



TOP VIEW

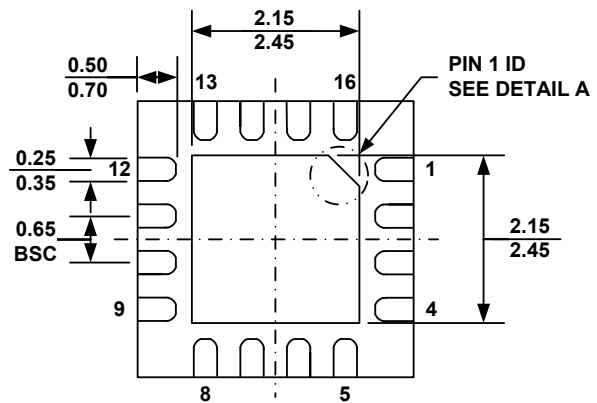

BOTTOM VIEW

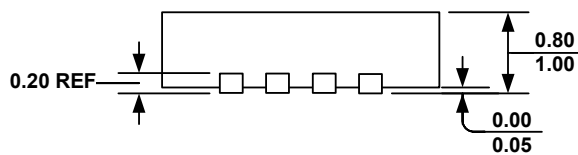

SIDE VIEW

PIN 1 ID OPTION A
0.45x45° TYP.

PIN 1 ID OPTION B
R0.25 TYP.



DETAIL A

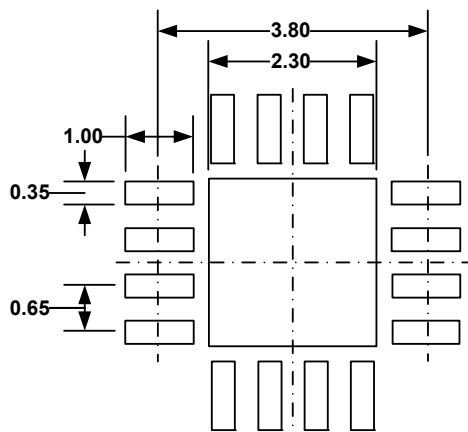

RECOMMENDED LAND PATTERN

NOTE:

- 1) ALL DIMENSIONS ARE IN MILLIMETERS.
- 2) EXPOSED PADDLE SIZE DOES NOT INCLUDE MOLD FLASH.
- 3) LEAD COPLANARITY SHALL BE 0.10 MILLIMETER MAX.
- 4) JEDEC REFERENCE IS MO-220, VARIATION VGGC.
- 5) DRAWING IS NOT TO SCALE.

NOTICE: The information in this document is subject to change without notice. Users should warrant and guarantee that third party Intellectual Property rights are not infringed upon when integrating MPS products into any application. MPS will not assume any legal responsibility for any said applications.

Looking for pricing, stock, or lifecycle information?

Click below to explore more details on WIN SOURCE:

- [View MP2610ER-LF-Z on WIN SOURCE](#)
- [Monolithic Power Systems Inc. Information](#)

Optimize Your Supply Chain with WIN SOURCE Solutions

- ✓ Global Sourcing Solution
- ✓ Obsolete Management
- ✓ Cost Control Management
- ✓ Shortage Management
- ✓ Alternative Solution
- ✓ Excess Inventory Management