



**THE DATASHEET OF
MP2370DJ-LF-P**



DESCRIPTION

The MP2370 is a monolithic step-down white LED driver with a built-in power MOSFET. It achieves 1.2A peak output current over a wide input supply range with excellent load and line regulation. Current mode operation provides fast transient response and eases loop stabilization. Fault condition protection includes cycle-by-cycle current limiting and thermal shutdown.

The MP2370 requires a minimum number of readily available standard external components. The MP2370 is available in a TSOT23-6 package and a TQFN-6 (2mmx2mm) package.

FEATURES

- 1.2A Peak Output Current
- 0.35Ω Internal Power MOSFET Switch
- Stable with Low ESR Output Ceramic Capacitors
- Also Work with Cap-less Configuration
- Up to 87% Efficiency
- 0.1μA Shutdown Mode
- Fixed 1.4MHz Frequency
- Thermal Shutdown
- Cycle-by-Cycle Over Current Protection
- Wide 4.5V to 24V Operating Input Range
- 0.15V Sense Voltage
- Available in a TSOT23-6 Package and a TQFN-6 (2mmx2mm) package

APPLICATIONS

- WLED Drivers
- Distributed Power Systems
- Battery Charger
- Pre-Regulator for Linear Regulators

All MPS parts are lead-free, halogen free, and adhere to the RoHS directive. For MPS green status, please visit MPS website under Quality Assurance.

"MPS" and "The Future of Analog IC Technology" are Registered Trademarks of Monolithic Power Systems, Inc.

TYPICAL APPLICATION

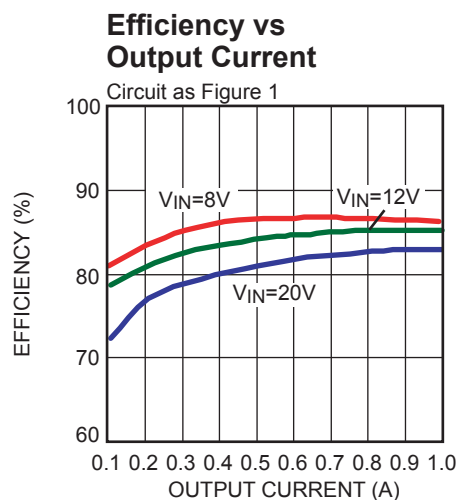
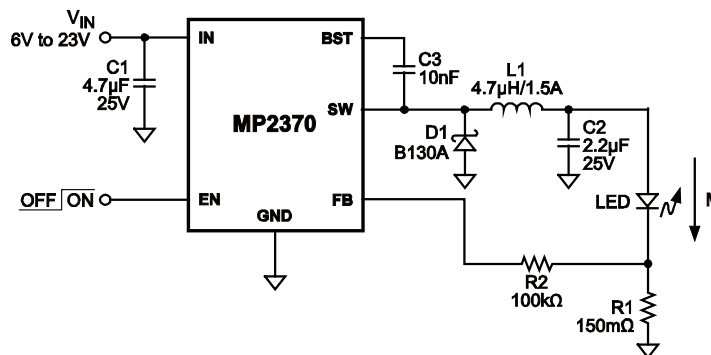

ORDERING INFORMATION

| Part Number* | Package | Top Marking |
|--------------|------------------|-------------|
| MP2370DJ | TSOT-6 | See below |
| MP2370DGT | TQFN-6 (2mmx2mm) | See below |

* For Tape & Reel, add suffix –Z (e.g. MP2370DJ-Z);
 For RoHS compliant packaging, add suffix –LF (eg. MP2370DJ-LF-Z)

* For Tape & Reel, add suffix –Z (e.g. MP2370DGT-Z);
 For RoHS compliant packaging, add suffix –LF (eg. MP2370DGT-LF-Z)

TOP MARKING (TSOT-6)

| P5YW

P5: product code of MP2370DJ;
 Y: year code;
 W: week code:

TOP MARKING (TQFN-6)

P5Y
LLL

P5: product code of MP2370DGT;
 Y: year code;
 LLL: lot number;

PACKAGE REFERENCE

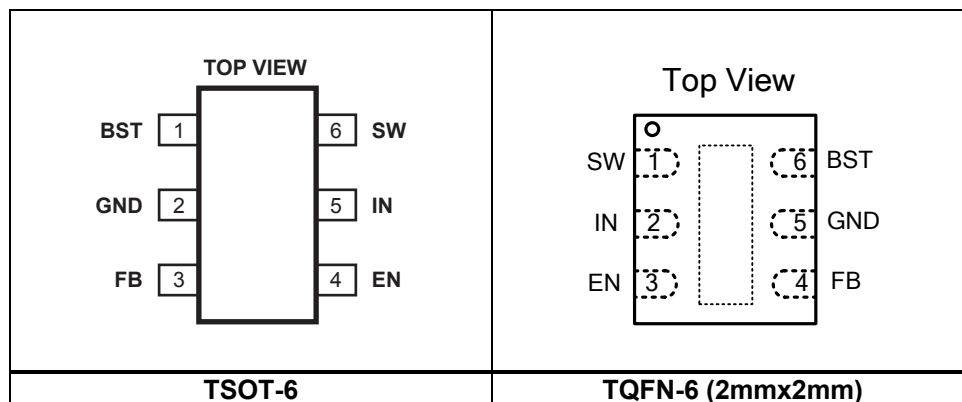

ABSOLUTE MAXIMUM RATINGS ⁽¹⁾

| | |
|-------------------------------|--------------------------|
| Supply Voltage V_{IN} | 26V |
| V_{SW} | -0.3V to $V_{IN} + 0.3V$ |
| V_{BST} | $V_{SW} + 6V$ |
| All Other Pins | -0.3V to +6V |
| Junction Temperature | 150°C |
| Lead Temperature | 260°C |
| Storage Temperature | -65°C to +150°C |

Recommended Operating Conditions ⁽²⁾

| | |
|--------------------------------|----------------|
| Supply Voltage V_{IN} | 4.5V to 24V |
| Output Voltage V_{OUT} | 0.15V to 15V |
| Ambient Temperature | -40°C to +85°C |

| Thermal Resistance ⁽³⁾ | θ_{JA} | θ_{JC} |
|--|---------------|---------------|
| TSOT23-6 | 220 | 110.. °C/W |
| TQFN-6 (2mmx2mm) | 80 | 16... °C/W |

Notes:

- 1) Exceeding these ratings may damage the device.
- 2) The maximum allowable power dissipation is a function of the maximum junction temperature T_J (MAX), the junction-to-ambient thermal resistance θ_{JA} , and the ambient temperature T_A . The maximum allowable continuous power dissipation at any ambient temperature is calculated by P_D (MAX) = $(T_J$ (MAX)- T_A)/ θ_{JA} . Exceeding the maximum allowable power dissipation will cause excessive die temperature, and the regulator will go into thermal shutdown. Internal thermal shutdown circuitry protects the device from permanent damage.
- 3) Measured on JESD51-7, 4-layer PCB.

ELECTRICAL CHARACTERISTICS

$V_{IN} = 12V$, $T_A = +25^{\circ}C$, unless otherwise noted.

| Parameters | Symbol | Condition | Min | Typ | Max | Units |
|--|---------------|--|-------|-------|-------|-------------|
| Feedback Voltage | V_{FB} | $4.5V \leq V_{IN} \leq 24V$ | 0.145 | 0.155 | 0.165 | V |
| Feedback Current | I_{FB} | $V_{FB} = 0.15V$ | | 0.1 | | μA |
| Switch-On Resistance ⁽⁴⁾ | $R_{DS(ON)}$ | | | 0.35 | | Ω |
| Switch Leakage | | $V_{EN} = 0V, V_{SW} = 0V$ | | | 10 | μA |
| Current Limit ⁽⁴⁾ | | | | 1.8 | | A |
| Oscillator Frequency | f_{SW} | $V_{FB} = 0.13V$ | 1.2 | 1.4 | 1.7 | MHz |
| Fold-back Frequency | | $V_{FB} = 0V$ | | 700 | | KHz |
| Maximum Duty Cycle | | $V_{FB} = 0.13V$ | | 87 | | % |
| Minimum On-Time ⁽⁴⁾ | t_{ON} | | | 100 | | ns |
| Under Voltage Lockout Threshold Rising | | | 2.5 | 2.8 | 3.1 | V |
| Under Voltage Lockout Threshold Hysteresis | | | | 150 | | mV |
| EN Input Low Voltage | | | | | 0.4 | V |
| EN Input High Voltage | | | 1.5 | | | V |
| EN Input Current | | $V_{EN} = 2V$ | | 2.1 | | μA |
| | | $V_{EN} = 0V$ | | 0.1 | | |
| Minimum PWM DIM On-Time on EN Pin | T_{MIN_ON} | $V_{OUT}=4.5V \quad 25^{\circ}C$ | | | 200 | μs |
| | | $V_{OUT}=4.5V$ $-40^{\circ}C \sim 125^{\circ}C^{(5)}$ | | | 240 | μs |
| Supply Current (Shutdown) | I_S | $V_{EN} = 0V$ | | 0.1 | 1.0 | μA |
| Supply Current (Quiescent) | I_Q | $V_{EN} = 2V, V_{FB} = 0.2V$ | | 0.8 | 1.0 | mA |
| Thermal Shutdown ⁽⁴⁾ | | | | 150 | | $^{\circ}C$ |

Note:

4) Guaranteed by design.

5) Not tested in production, guaranteed by over -temperature correlation.

PIN FUNCTIONS

| TSOT-6 Pin # | QFN-6 Pin # | Name | Description |
|-----------------|----------------|------|---|
| 1 | 6 | BST | Bootstrap. A capacitor is connected between SW and BS pins to form a floating supply across the power switch driver. This capacitor is needed to drive the power switch's gate above the supply voltage. |
| 2 | 5 | GND | Ground. This pin is the voltage reference for the regulated output voltage. For this reason care must be taken in its layout. This node should be placed outside of the D1 to C1 ground path to prevent switching current spikes from inducing voltage noise into the part. |
| 3 | 4 | FB | Current Sense Feedback Voltage. Its internal threshold is 0.15V. |
| 4 | 3 | EN | On/Off Control Input. Pull EN above 1.2V to turn the device on. |
| 5 | 2 | IN | Supply Voltage. The MP2370 operates from a +4.5V to +24V unregulated input. Input Capacitor is needed to prevent large voltage spikes from appearing at the input. |
| 6 | 1 | SW | Switch Output. |

TYPICAL PERFORMANCE CHARACTERISTICS

Circuit as Figure 1, $V_{IN} = 12V$, Load: one 3 Watt White LED, unless otherwise noted.

Steady State Operation

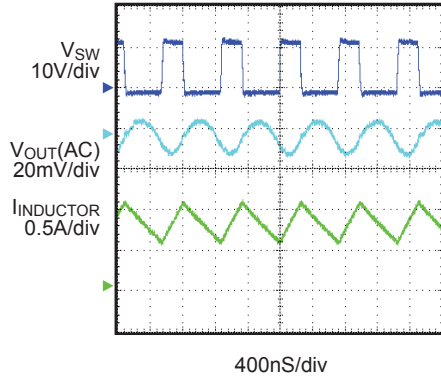

Enable Start Up

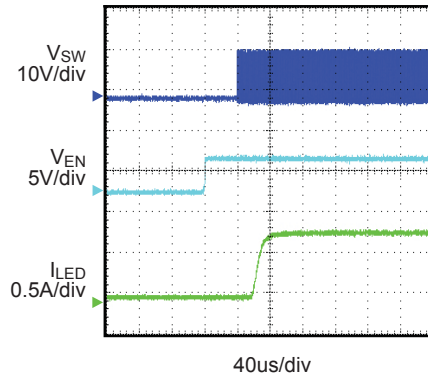

Enable Turn Off

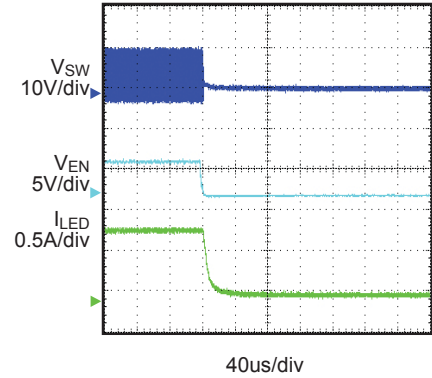

Output Short

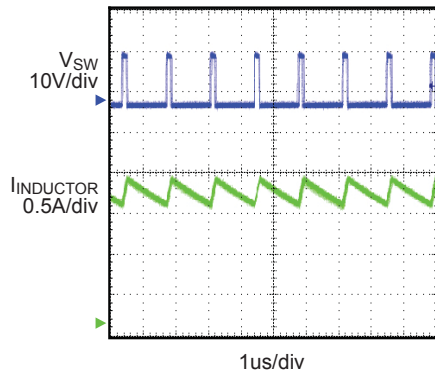

Output Short Entry

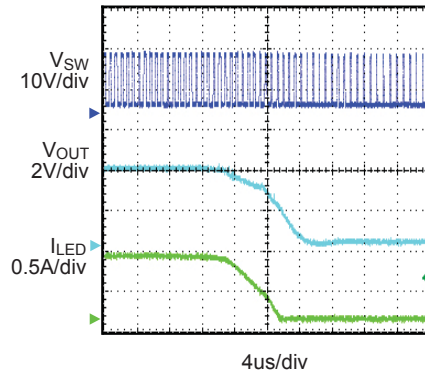

Output Short Recovery

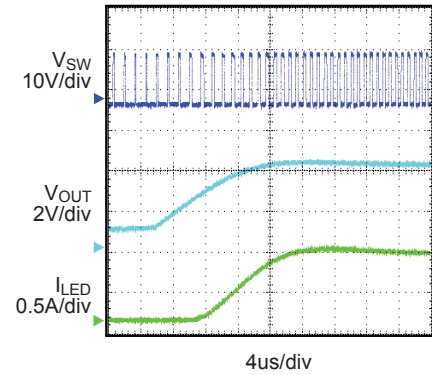

PWM Dimming

$I_{LED-MAX} = 760mA$
 PWM Frequency = 1kHz, Duty = 50%

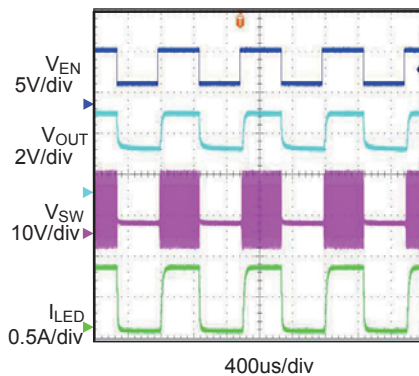

Output Current vs PWM Dimming Duty

PWM Frequency = 1kHz

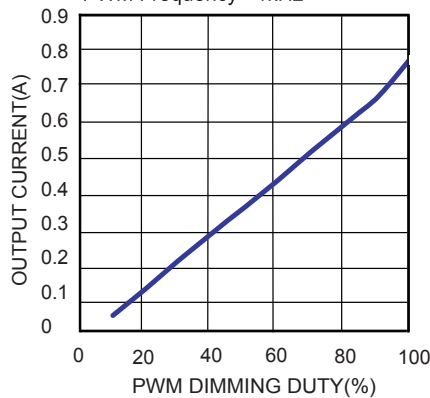

Current Limit vs Duty Cycle

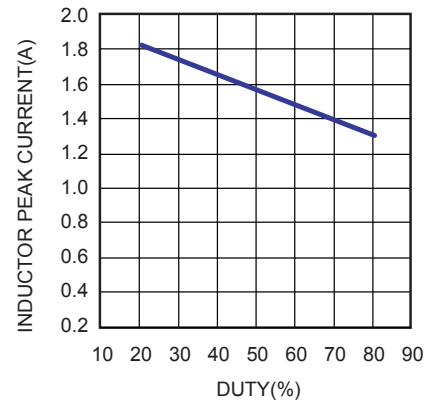

OPERATION

The MP2370 is a current mode buck regulator. That is, the EA output voltage is proportional to the peak inductor current.

At the beginning of a cycle, M1 is off. The EA output voltage is higher than the current sense amplifier output, and the current comparator's output is low. The rising edge of the 1.4MHz CLK signal sets the RS Flip-Flop. Its output turns on M1 thus connecting the SW pin and inductor to the input supply.

The increasing inductor current is sensed and amplified by the Current Sense Amplifier. Ramp compensation is summed to the Current Sense Amplifier output and compared to the Error Amplifier output by the PWM Comparator. When the sum of the Current Sense Amplifier output and the Slope Compensation signal exceeds the EA output voltage, the RS Flip-Flop is reset and M1 is turned off. The external Schottky rectifier diode (D1) conducts the inductor current.

If the sum of the Current Sense Amplifier output and the Slope Compensation signal does not exceed the EA output for a whole cycle, then the falling edge of the CLK resets the Flip-Flop.

The output of the Error Amplifier integrates the voltage difference between the feedback and the 0.15V bandgap reference. The polarity is such that a FB pin voltage lower than 0.15V increases the EA output voltage. Since the EA output voltage is proportional to the peak inductor current, an increase in its voltage also increases current delivered to the output.

The internal floating power MOSFET driver (M1) is powered by an external bootstrap capacitor. When M1 turns off and when external Schottky turns on, the bootstrap capacitor is charged through the internal diode (D) and regulator. For application with lower input voltage, connect the external diode between the IN pin and BST pin to enhance the floating MOS driver capability.

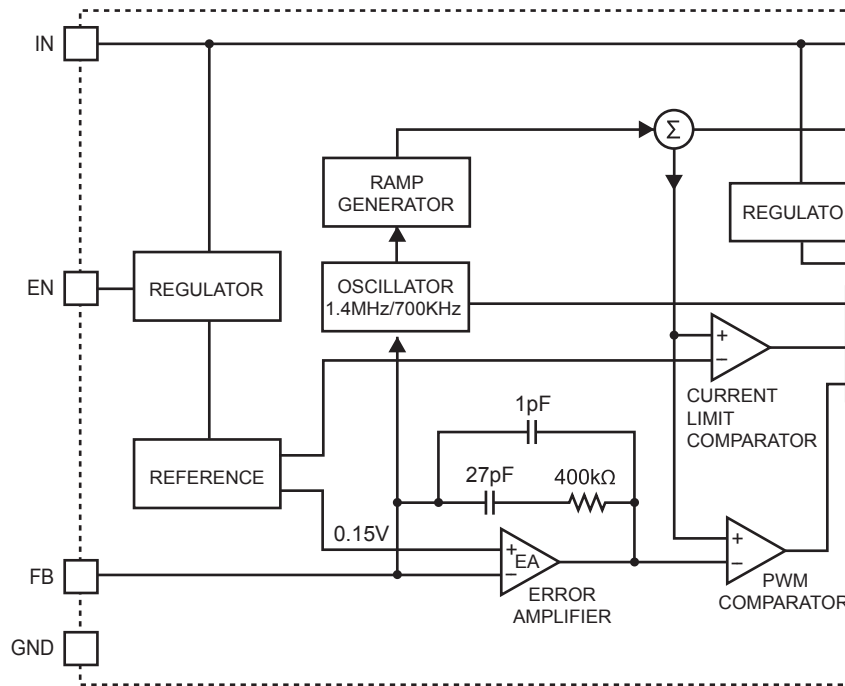

Figure 1—Functional Block Diagram

APPLICATION INFORMATION

Setting LED Current

The current sense resistor is inserted between the anode of WLED and GND. The current sense resistor value is calculated as:

$$R1 = \frac{0.15V}{I_{LED}}$$

For 1A WLED current, choose $R1 = 150m\Omega$

Selecting the Inductor

A $1\mu H$ to $10\mu H$ inductor with a DC current rating of at least 25% percent higher than the maximum load current is recommended for most applications. For highest efficiency, the inductor's DC resistance should be less than $200m\Omega$. Refer to Table 2 for suggested surface mount inductors. For most designs, the required inductance value can be derived from the following equation.

$$L = \frac{V_{OUT} \times (V_{IN} - V_{OUT})}{V_{IN} \times \Delta I_L \times f_{SW}}$$

Where ΔI_L is the inductor ripple current.

Choose the inductor ripple current to be 30% of the maximum load current. The maximum inductor peak current is calculated from:

$$I_{L(MAX)} = I_{LOAD} + \frac{\Delta I_L}{2}$$

Under light load conditions below 100mA, a larger inductance is recommended to improve efficiency. See Table 2 for suggested inductors.

Also note that the maximum recommended load current is 1A if the duty cycle exceeds 35%.

Selecting the Input Capacitor

The input capacitor reduces the surge current drawn from the input supply and the switching noise from the device. The input capacitor impedance at the switching frequency should be less than the output impedance of the input source to prevent high frequency switching current from passing through the input. Ceramic capacitors with X5R or X7R dielectrics are highly recommended because of their low ESR and small temperature coefficients. For most applications, a $4.7\mu F$ capacitor is sufficient.

Selecting the Output Capacitor

The output capacitor keeps the output current ripple small and ensures feedback loop stability. The output capacitor impedance should be low at the switching frequency. Ceramic capacitors with X5R or X7R dielectrics are recommended for their low ESR characteristics. For most applications, a $2.2\mu F$ ceramic capacitor will be sufficient.

The MP2370 can also work properly without output capacitor by adding a small capacitor in the feedback loop (see Figure 2). The small capacitor is recommended $680pF$.

PC Board Layout

The high current paths (GND, IN and SW) should be placed very close to the device with short, direct and wide traces. The input capacitor needs to be as close as possible to the IN and GND pins. The external feedback resistors should be placed next to the FB pin. Keep the switch node traces short and away from the feedback network.

External bootstrap diode

To get the full rated output current when operating at low input voltage ($V_{in} < 5V$), an external BST diode may be connected from IN pin to BST pin to charge the bootstrapped capacitor more strongly for increased gate drive voltage as shown in Figure 2.

When using an external BST diode the input voltage is not allowed to exceed 6V plus the voltage dropped across the diode.

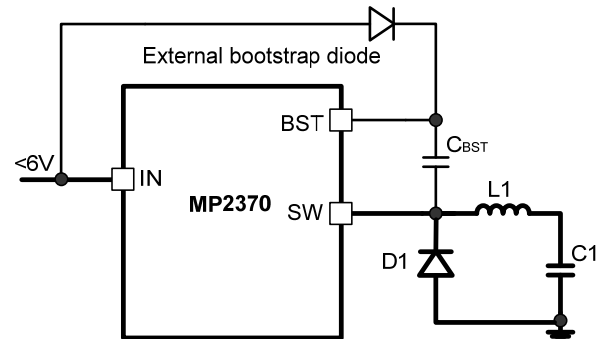

Figure 2—Add Optional External Bootstrap Diode to enhance the driver capability

PWM Dimming

MP2370 has PWM dimming function on EN pin with dimming signal. The dimming ratio depends on the dimming frequency. The lower PWM

dimming frequency, the deeper dimming ratio is accomplished. In order to get good linear dimming performance, it is recommended to employ >240us on-time PWM dimming signal.

Table 2—Suggested Surface Mount Inductors

| Manufacturer | Part Number | Inductance(μ H) | Max DCR(Ω) | Current Rating (A) | Dimensions L x W x H (mm ³) |
|-------------------|--------------|----------------------|---------------------|--------------------|---|
| Toko | A921CY-4R7M | 4.7 | 0.027 | 1.66 | 6 x 6.3 x 3 |
| Sumida | CDRH4D28C/LD | 4.7 | 0.036 | 1.5 | 5.1 x 5.1 x 3 |
| Würth Electronics | 7440530047 | 4.7 | 0.038 | 2.0 | 5.8 x 5.8 x 2.8 |

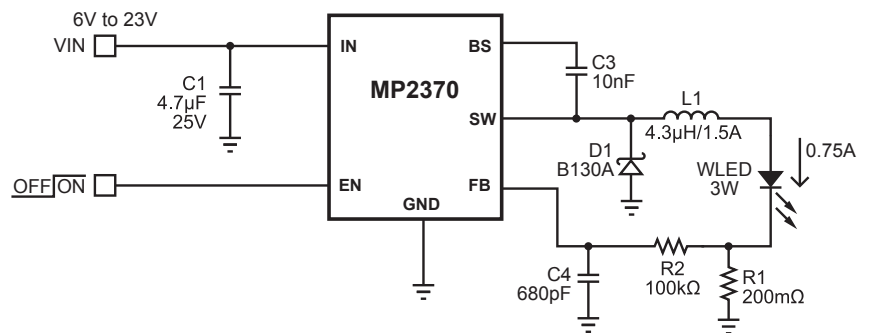
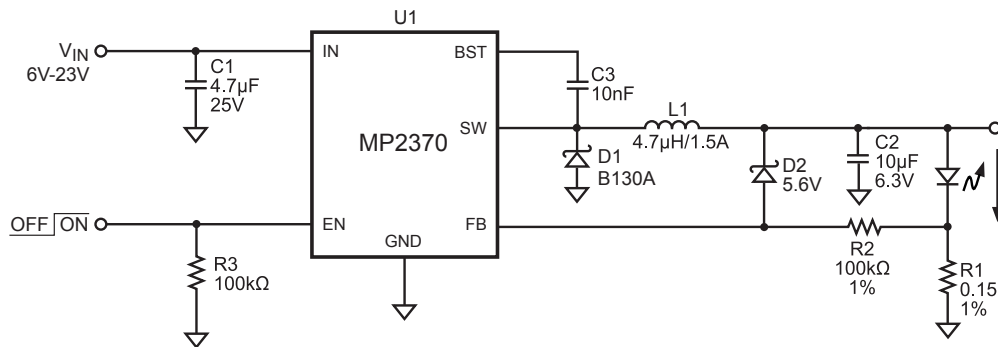
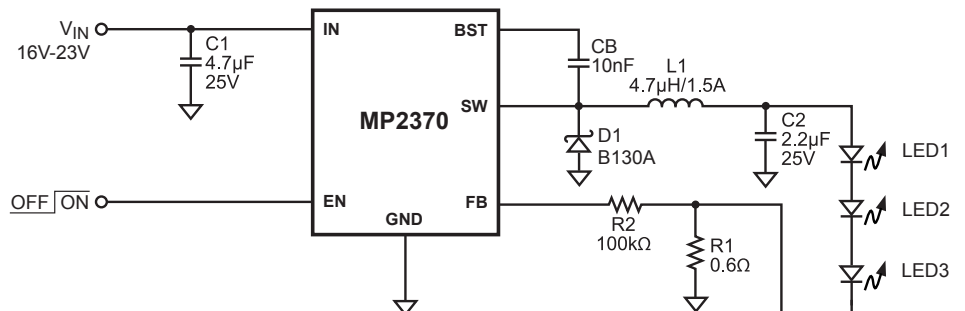
TYPICAL APPLICATION CIRCUITS

Figure 3—White LED Driver without Output Capacitor

Figure 4—White LED Driver with Over-Voltage Clamp Output

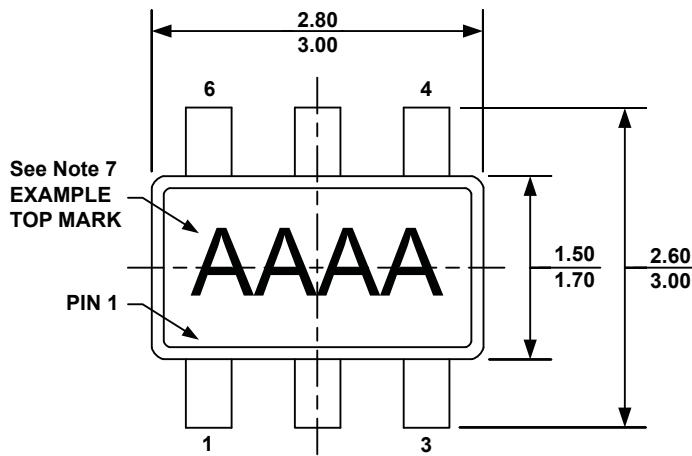
Figure 5—Driving 3 White LEDs in Series from 16V- 23V Input Voltage

PACKAGE INFORMATION

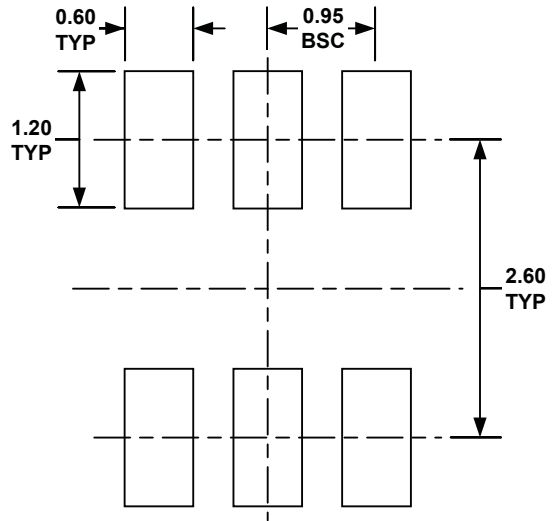
TSOT23-6



TOP VIEW



RECOMMENDED LAND PATTERN

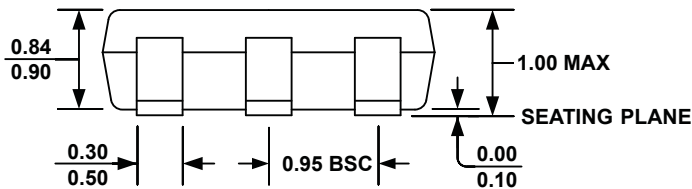

FRONT VIEW

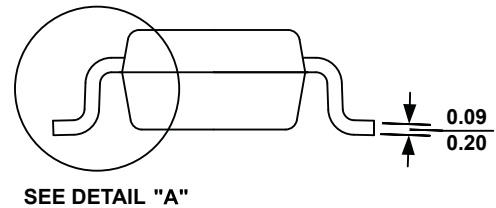

SIDE VIEW

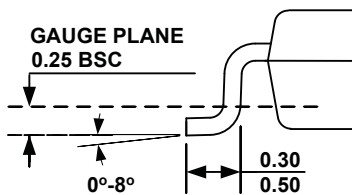

DETAIL "A"

NOTE:

- 1) ALL DIMENSIONS ARE IN MILLIMETERS.
- 2) PACKAGE LENGTH DOES NOT INCLUDE MOLD FLASH, PROTRUSION OR GATE BURR.
- 3) PACKAGE WIDTH DOES NOT INCLUDE INTERLEAD FLASH OR PROTRUSION.
- 4) LEAD COPLANARITY (BOTTOM OF LEADS AFTER FORMING) SHALL BE 0.10 MILLIMETERS MAX.
- 5) DRAWING CONFORMS TO JEDEC MO-193, VARIATION AB.
- 6) DRAWING IS NOT TO SCALE.
- 7) PIN 1 IS LOWER LEFT PIN WHEN READING TOP MARK FROM LEFT TO RIGHT, (SEE EXAMPLE TOP MARK)

PACKAGE INFORMATION

TQFN-6 (2mmx2mm)

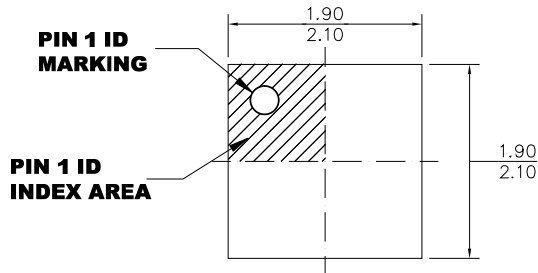

TOP VIEW

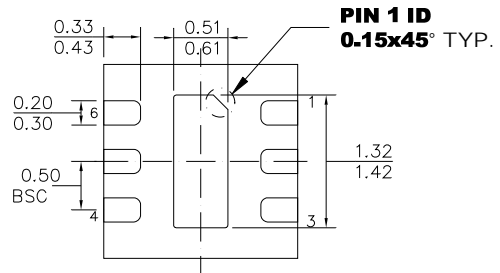

BOTTOM VIEW

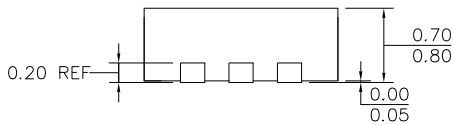

SIDE VIEW

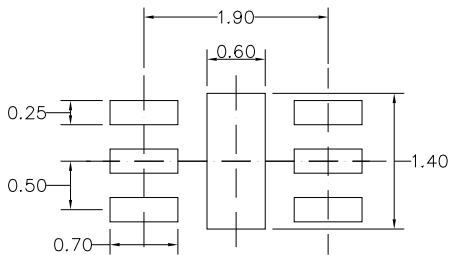

RECOMMENDED LAND PATTERN

NOTE:

- 1) ALL DIMENSIONS ARE IN MILLIMETERS.
- 2) EXPOSED PADDLE SIZE DOES NOT INCLUDE MOLD FLASH.
- 3) LEAD COPLANARITY SHALL BE 0.10 MILLIMETERS MAX.
- 4) JEDEC REFERENCE IS MO-229, VARIATION WCCC
- 5) DRAWING IS NOT TO SCALE.

NOTICE: The information in this document is subject to change without notice. Please contact MPS for current specifications. Users should warrant and guarantee that third party Intellectual Property rights are not infringed upon when integrating MPS products into any application. MPS will not assume any legal responsibility for any said applications.

Looking for pricing, stock, or lifecycle information?

Click below to explore more details on WIN SOURCE:

- [View MP2370DJ-LF-P on WIN SOURCE](#)
- [Monolithic Power Systems Inc. Information](#)

Optimize Your Supply Chain with WIN SOURCE Solutions

- ✓ Global Sourcing Solution
- ✓ Obsolete Management
- ✓ Cost Control Management
- ✓ Shortage Management
- ✓ Alternative Solution
- ✓ Excess Inventory Management