



**THE DATASHEET OF
MN1382SKP**



MN1382S

CMOS IC for Voltage Detection

■ Overview

The MN1382S are elements that monitor the power supply voltage supplied to microcomputers and other LSI systems and issue reset signals for initializing the system after the power is first applied or for preventing runaway operation when the supply voltage fluctuates.

This is a CMOS output, choose the ideal element for your application from the series' wide selection of detection ranks (16 ranks 2.0 V to 4.7 V).

There is other output type, N-channel open drain output (MN13821S) and inverted CMOS output (MN13822S).

■ Features

- Three-pin element requiring no adjustment
- Wide selection of detection ranks (16 ranks 2.0 V to 4.7 V)
- Highly precise detection voltage
- Detection voltage with hysteresis characteristic
 $\Delta V_D = 50 \text{ mV}$ for ranks C to K
 $\Delta V_D = 100 \text{ mV}$ for ranks L to T
- Low current consumption: $I_{DD} = 1 \mu\text{A}$ (typ.) for $V_{DD} = 5 \text{ V}$
- Low fluctuation in detection voltage with temperature (1 mV/°C (typ.))

■ Applications

- Battery checkers
- Power outage detectors
- Level discriminators
- Memory backup systems
- Microcomputer reset circuits
- Reset circuits for other electronic circuits

■ Block Diagram

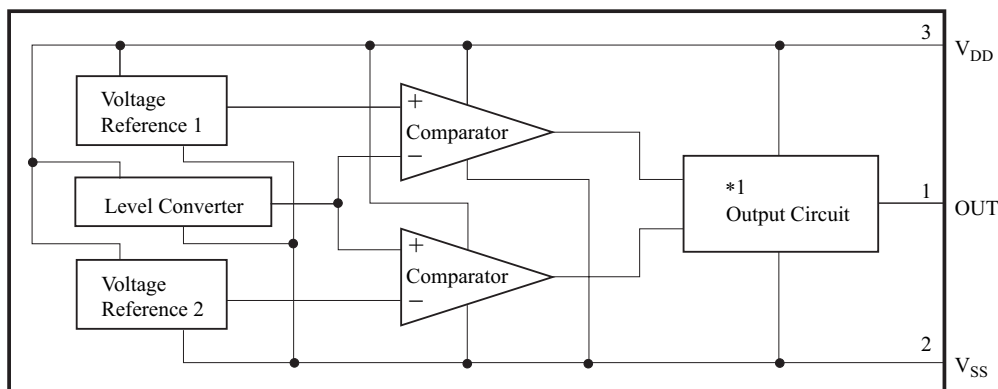

Note) *1: Circuits vary slightly depending on the output type (CMOS output, N-channel open drain output, or inverted CMOS output)

■ Package

- Code
MINI-3DC
- Pin name
 1: Out Reset signal output pin
 2: V_{SS} Ground pin
 3: V_{DD} Power supply pin

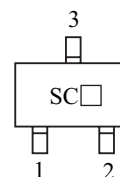

Note) Rank symbol will be marked on the package in the □ area.

■ Detection Ranks (on Voltage)

Rank	Detection Voltage for Drop in Power Supply Voltage V_{DL}		Unit	Detection Voltage Hysteresis Width ΔV_D		Unit
	Min	Max		Min	max	
C	2.0	2.2	V	50	300	mV
D	2.1	2.3				
E	2.2	2.4				
F	2.3	2.5				
G	2.4	2.6				
H	2.5	2.7				
J	2.6	2.9				
K	2.8	3.1		100		
L	3.0	3.3				
M	3.2	3.5				
N	3.4	3.7				
P	3.6	3.9				
Q	3.8	4.1				
R	4.0	4.3				
S	4.2	4.5				
T	4.4	4.7				

■ Absolute Maximum Ratings $V_{SS} = 0\text{ V}$, $T_a = 25^\circ\text{C}$

Parameter	Symbol	Rating	Unit
Power supply voltage	V_{DD}	7.0	V
Output voltage	V_O	-0.3 to $V_{DD} + 0.3$	V
Operating ambient temperature	T_{opr}	-20 to +70	$^\circ\text{C}$
Storage temperature	T_{stg}	-55 to +125	$^\circ\text{C}$

■ Recommended Operating Conditions $V_{SS} = 0\text{ V}$, $T_a = 25^\circ\text{C}$

Parameter	Symbol	Conditions	Min	Typ	Max	Unit
Power supply voltage	V_{DD}	See Figures 1 and 4	1.5		6.0	V

■ Application Circuit Example



Note) Connect resistors, capacitors, and the like only to the output pin on the MN1382S element.

Note that connect-ing them to the power source pins changes V_{DH} , V_{DL} , and ΔV_D . Select the values of R and C to match the application.

■ Electrical Characteristics

• DC Characteristics $V_{SS} = 0\text{ V}$, $T_a = -20^\circ\text{C}$ to $+70^\circ\text{C}$

Parameter	Symbol	Conditions	Min	Typ	Max	Unit
Power supply current	I_{DD}	$V_{DD} = 5\text{ V}^*$, Load resistor $10\text{ k}\Omega$		1	5	μA
Detection voltage for drop in power supply voltage	V_{DL}	$T_a = 25^\circ\text{C}$	For particulars, see the detection voltage rank table.			V
Detection voltage hysteresis width	ΔVD	See Figures 1 and 4				mV
High level output voltage	V_{OH}	$I_{OH} = -40\ \mu\text{A}$	$0.8 V_{DD}$		V_{DD}	V
Low level output voltage	V_{OL}	$V_{DD} = 1.8\text{ V}$, $I_{OH} = 0.7\text{ mA}$	V_{SS}		0.4	V

Note) *: This includes the output pin's leakage current.

• AC Characteristics $V_{SS} = 0\text{ V}$, $T_a = 25^\circ\text{C}$

Parameter	Symbol	Conditions	Rank	Allowable Value (typ)	Unit
Reset release time	t_{OH}	See Figures 2 and 3	C	3.0	μs
			D		
			E		
			F		
			G		
			H		
			J		
			K		
			L		
			M	4.0	
			N		
			P		
			Q		
			R		
S					
T					
Reset time	t_{OL}	See Figures 2 and 3	C	250.0	μs
			D		
			E		
			F		
			G	115.0	
			H		
			J		
			K		
			L	70.0	
			M	15.0	
			N		
			P		
			Q		
			R		
S					
T					

■ Reference Data

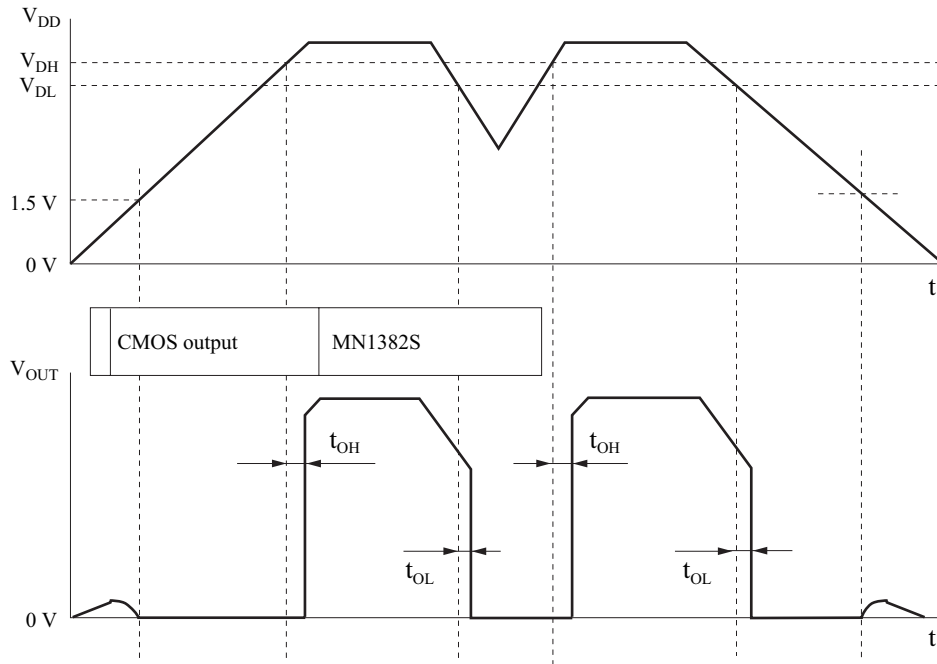

Figure 1. Description of Operation

Note) 1. Output cannot be specified for power supply voltages under 1.5 V because operation is not guaranteed for that range.

2. V_{DL} : Detection voltage for drop in power supply voltage

V_{DH} : Detection voltage for rise in power supply voltage

t_{OL} : Time lag between the time that the power supply voltage reaches the detection voltage (V_{DL} or V_{DH}) and the time that the output pin (OUT) goes to Low level.

t_{OH} : Time lag between the time that the power supply voltage reaches the detection voltage (V_{DL} or V_{DH}) and the time that the output pin (OUT) goes to High level.

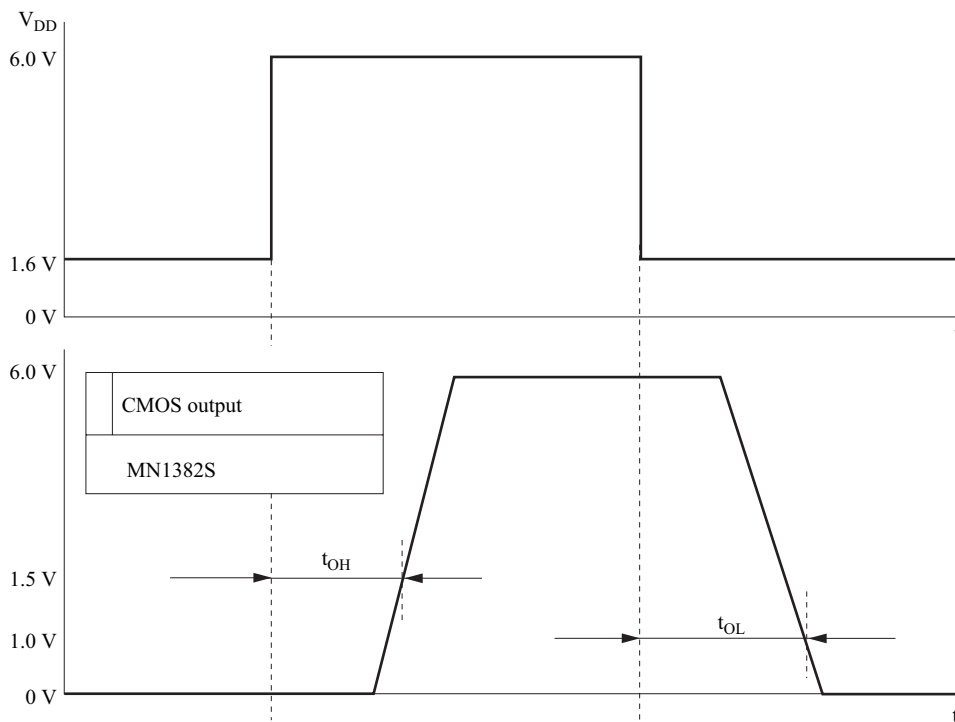

Figure 2. Description chart of Measuring the Output Characteristics

■ Reference Data (Continued)

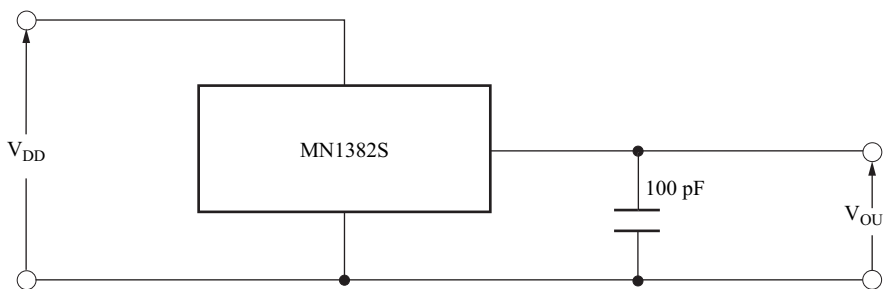

Figure 3. Circuit for Measuring the Output Characteristics

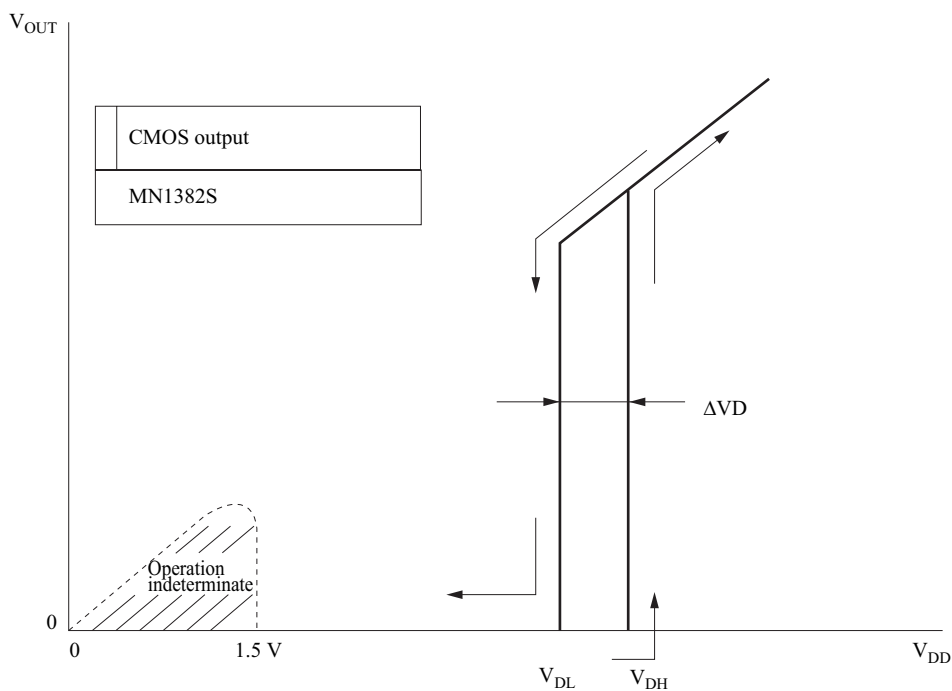

Figure 4. Description chart for Measuring the I/O Characteristics

- Note) 1. Output cannot be specified for power supply voltages under 1.5 V because operation is not guaranteed for that range.
 2. V_{DL} : Detection voltage for drop in power supply voltage
 V_{DH} : Detection voltage for rise in power supply voltage

■ Reference Characteristics

The following characteristics curves represent results from a specific sample therefore they do not guarantee the characteristics for the final product.

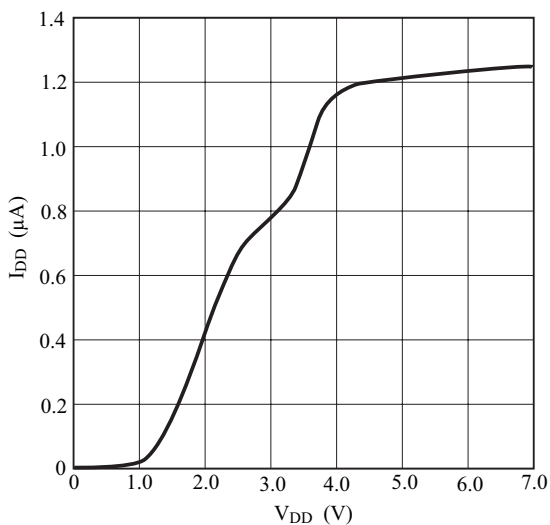

Figure 5-a I_{DD} — V_{DD} Characteristic (Rank Q)

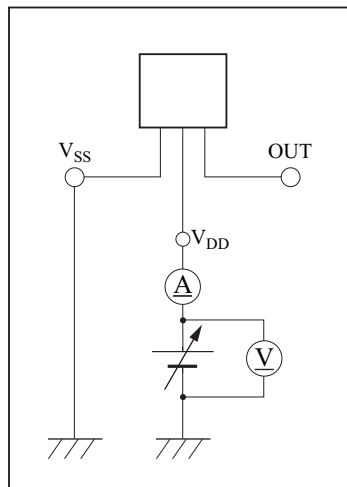

Figure 5-b Measurement Circuit

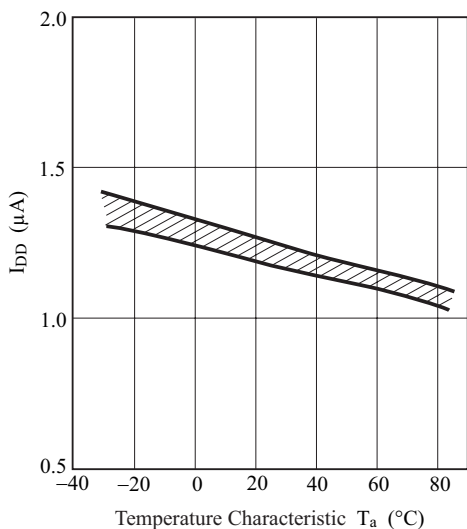

Figure 6-a I_{DD} — Temperature Characteristic (Rank Q)

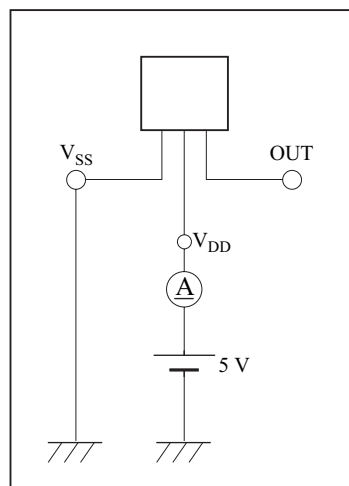

Figure 6-b Measurement Circuit

■ Reference Characteristics (Continued)

The following characteristics curves represent results from a specific sample therefore they do not guarantee the characteristics for the final product.

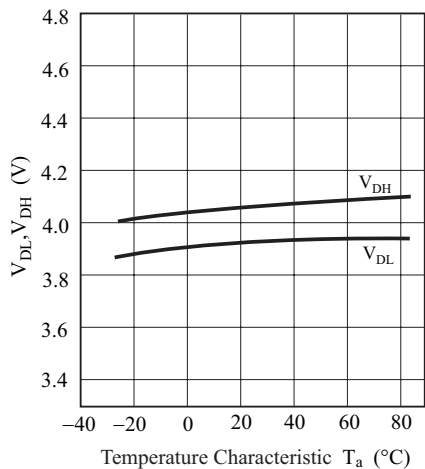

Figure 7-a V_{DL} — V_{DH} Temperature Characteristic (Rank Q)

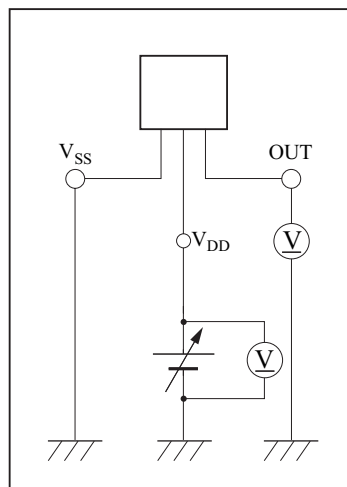

Figure 7-b Measurement Circuit

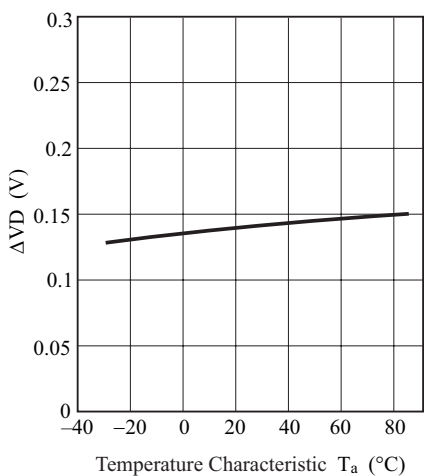

Figure 8-a ΔV_D Temperature Characteristic (Rank Q)

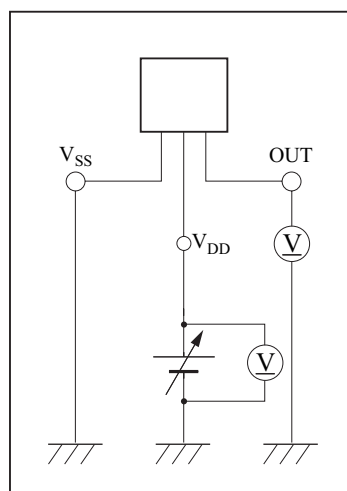

Figure 8-b Measurement Circuit

■ Reference Characteristics (Continued)

The following characteristics curves represent results from a specific sample therefore they do not guarantee the characteristics for the final product.

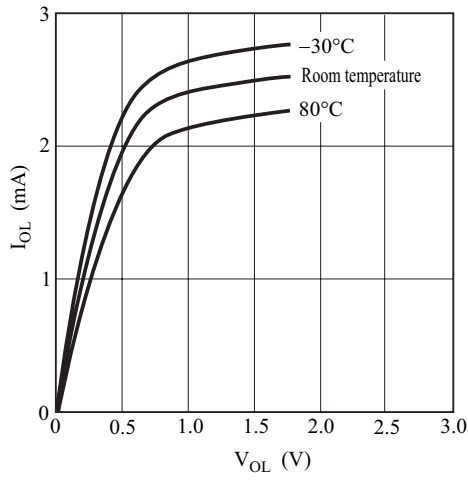

Figure 9-a I_{OL} — V_{DL} Characteristic

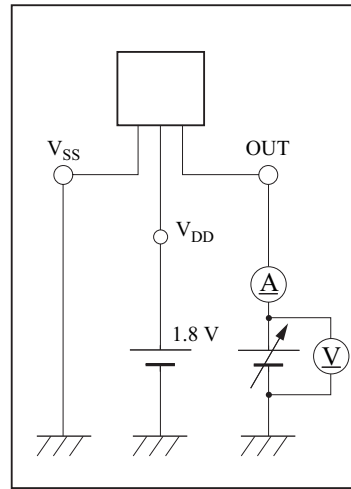

Figure 9-b Measurement Circuit

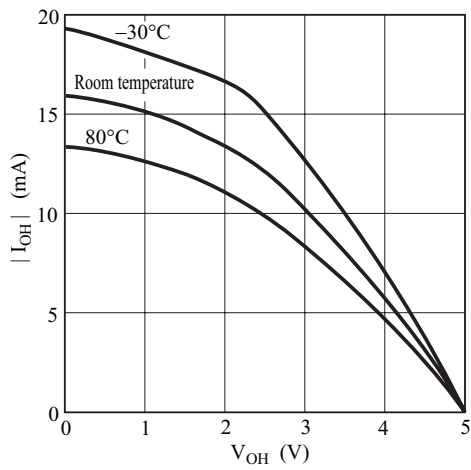

Figure 10-a I_{OH} — V_{OH} Characteristic

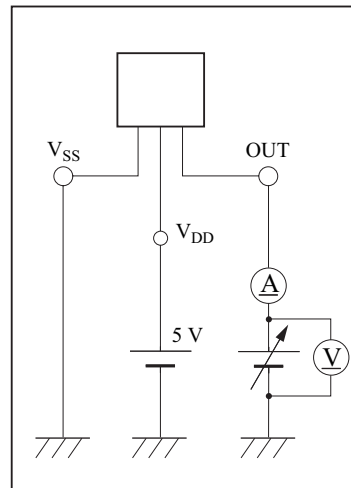

Figure 10-b Measurement Circuit

■ Reference Characteristics (Continued)

The following characteristics curves represent results from a specific sample therefore they do not guarantee the characteristics for the final product.

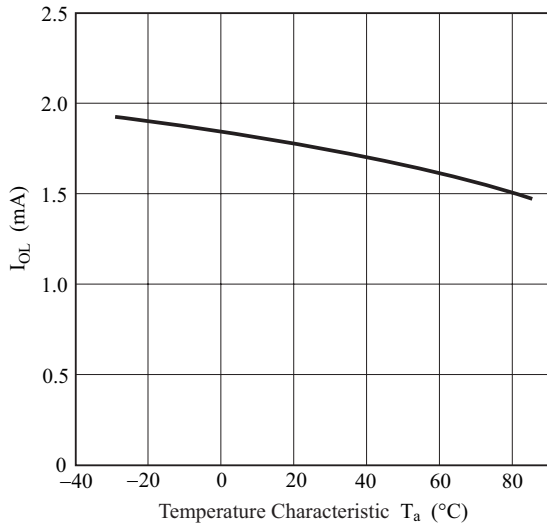

Figure 11-a I_{OL} — Temperature Characteristic

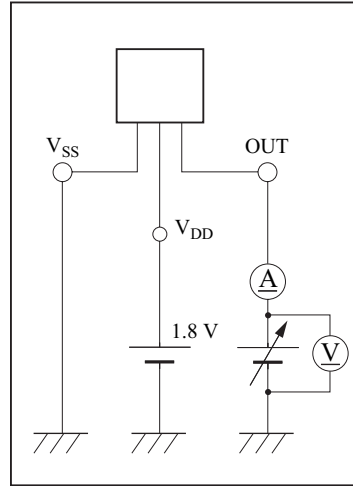

Figure 11-b Measurement Circuit

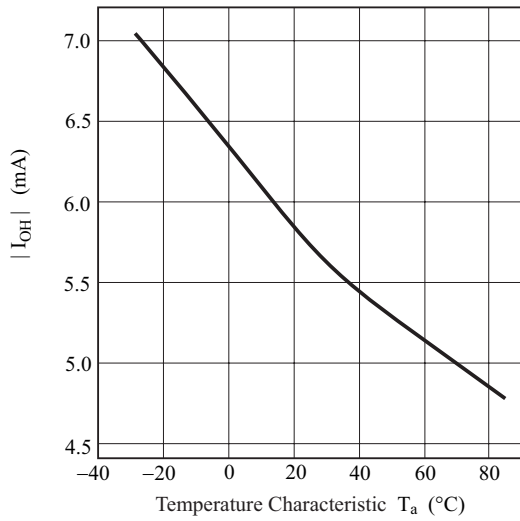

Figure 12-a I_{OH} — Temperature Characteristic

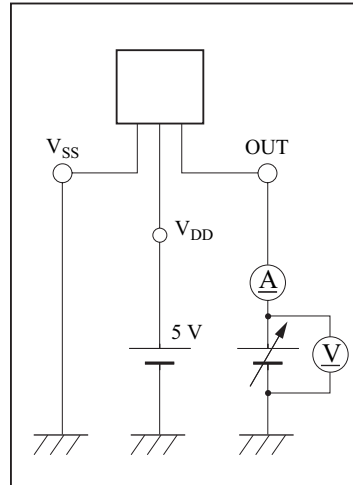
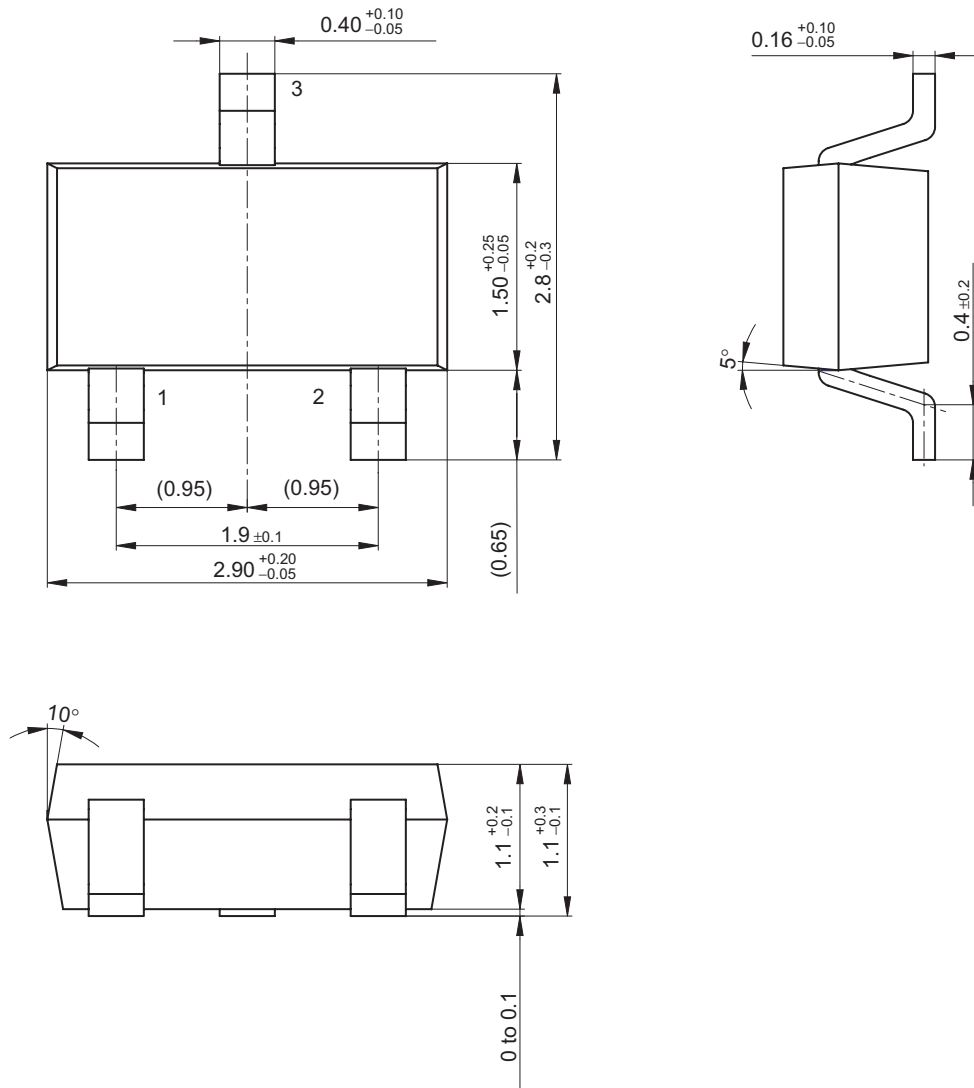



Figure 12-b Measurement Circuit

MINI-3DC



Looking for pricing, stock, or lifecycle information?

Click below to explore more details on WIN SOURCE:

-  [View MN1382SKP](#) on WIN SOURCE
-  [Panasonic](#) Information

Optimize Your Supply Chain with WIN SOURCE Solutions

-  Global Sourcing Solution
-  Obsolete Management
-  Cost Control Management
-  Shortage Management
-  Alternative Solution
-  Excess Inventory Management