



**THE DATASHEET OF
MMT05A310T3G**



MMT05A230T3, MMT05A260T3, MMT05A310T3

Preferred Devices

Thyristor Surge Protectors

High Voltage Bidirectional TSPD

These Thyristor Surge Protective devices (TSPD) prevent overvoltage damage to sensitive circuits by lightning, induction and power line crossings. They are breakover-triggered crowbar protectors. Turn-off occurs when the surge current falls below the holding current value.

Secondary protection applications for electronic telecom equipment at customer premises.

- High Surge Current Capability: **50 Amps** 10 x 1000 μ sec; for Controlled Temperature Environments in the **SMA** package
- The MMT05A230T3 Series is used to help equipment meet various regulatory requirements including: Telcordia 1089, ITU K.20 & K.21, IEC 950 and FCC Part 68
- Bidirectional Protection in a Single Device
- Little Change of Voltage Limit with Transient Amplitude or Rate
- Freedom from Wearout Mechanisms Present in Non-Semiconductor Devices
- Fail-Safe, Shorts When Overstressed, Preventing Continued Unprotected Operation
- Surface Mount Technology (SMT)
-  Indicates UL Registered – File #E210057
- Device Marking: MMT05A230T3: PBF; MMT05A260T3: PBG; MMT05A310T3: PBJ

MAXIMUM RATINGS ($T_J = 25^\circ\text{C}$ unless otherwise noted)

Rating	Symbol	Value	Unit
Off-State Voltage – Maximum MMT05A230T3 MMT05A260T3 MMT05A310T3	V_{DM}	± 170 ± 200 ± 270	Volts
Maximum Pulse Surge Short Circuit Current Non-Repetitive Double Exponential Decay Waveform (Notes 1 and 2) 8 x 20 μ sec 10 x 160 μ sec 10 x 560 μ sec 10 x 1000 μ sec	I_{PPS1} I_{PPS2} I_{PPS3} I_{PPS4}	± 150 ± 100 ± 70 ± 50	A(pk)
Maximum Non-Repetitive Rate of Change of On-State Current Double Exponential Waveform, $I_{PK} = 50$ A, $P_W = 15$ μ s	di/dt	± 100	A/ μ s

1. Allow cooling before testing second polarity.
2. Measured under pulse conditions to reduce heating.



ON Semiconductor®

<http://onsemi.com>

BIDIRECTIONAL TSPD 50 AMP SURGE 265 thru 365 VOLTS

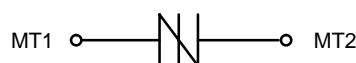

SMA
(No Polarity)
CASE 403D

MARKING DIAGRAM



xxx = Specific Device Code
A = Assembly Location
Y = Year
W = Work Week

ORDERING INFORMATION

Device	Package	Shipping†
MMT05A230T3	SMA	12 mm Tape and Reel (5 K/Reel)
MMT05A260T3	SMA	12 mm Tape and Reel (5 K/Reel)
MMT05A310T3	SMA	12 mm Tape and Reel (5 K/Reel)

†For information on tape and reel specifications, including part orientation and tape sizes, please refer to our Tape and Reel Packaging Specification Brochure, BRD8011/D.

Preferred devices are recommended choices for future use and best overall value.

MMT05A230T3, MMT05A260T3, MMT05A310T3

THERMAL CHARACTERISTICS

Characteristic	Symbol	Max	Unit
Operating Temperature Range Blocking or Conducting State	T_{J1}	-40 to +125	°C
Overload Junction Temperature – Maximum Conducting State Only	T_{J2}	+175	°C
Instantaneous Peak Power Dissipation ($I_{pk} = 50A, 10 \times 1000 \mu\text{sec} @ 25^\circ\text{C}$)	P_{PK}	2000	W
Maximum Lead Temperature for Soldering Purposes 1/8" from Case for 10 Seconds	T_L	260	°C

ELECTRICAL CHARACTERISTICS ($T_J = 25^\circ\text{C}$ unless otherwise noted)

Devices are bidirectional. All electrical parameters apply to forward and reverse polarities.

Characteristics	Symbol	Min	Typ	Max	Unit
Breakover Voltage (Both polarities) ($dv/dt = 100 \text{ V}/\mu\text{s}, I_{SC} = 1.0 \text{ A}, V_{dc} = 1000 \text{ V}$) (+65°C)	$V_{(BO)}$	-	-	265 320 365 280 340 400	Volts
Breakover Voltage (Both polarities) ($f = 60 \text{ Hz}, I_{SC} = 1.0 \text{ A(rms)}, V_{OC} = 1000 \text{ V(rms)}, R_I = 1.0 \text{ k}\Omega, t = 0.5 \text{ cycle}$) (Note 3) (+65°C)	$V_{(BO)}$	-	-	265 320 365 280 340 400	Volts
Breakover Voltage Temperature Coefficient	$dV_{(BO)}/dT_J$	-	0.08	-	%/°C
Breakdown Voltage ($I_{(BR)} = 1.0 \text{ mA}$) Both polarities	$V_{(BR)}$	-	190 240 280	-	Volts
Off State Current ($V_{D1} = 50 \text{ V}$) Both polarities ($V_{D2} = V_{DM}$) Both polarities	I_{D1} I_{D2}	-	-	2.0 5.0	μA
On-State Voltage ($I_T = 1.0 \text{ A}$) ($PW \leq 300 \mu\text{s}, \text{Duty Cycle} \leq 2\%$) (Note 3)	V_T	-	1.53	3.0	Volts
Breakover Current ($f = 60 \text{ Hz}, V_{DM} = 1000 \text{ V(rms)}, R_S = 1.0 \text{ k}\Omega$) Both polarities	I_{BO}	-	230	-	mA
Holding Current (Both polarities) (Note 3) $V_S = 500 \text{ Volts}; I_T$ (Initiating Current) = $\pm 1.0 \text{ Amp}$	I_H	150	340	-	mA
Critical Rate of Rise of Off-State Voltage (Linear waveform, $V_D = \text{Rated } V_{BR}, T_J = 25^\circ\text{C}$)	dv/dt	2000	-	-	$\text{V}/\mu\text{s}$
Capacitance ($f = 1.0 \text{ MHz}, 50 \text{ Vdc}, 1.0 \text{ V(rms)}$ Signal) ($f = 1.0 \text{ MHz}, 2.0 \text{ Vdc}, 1.0 \text{ V(rms)}$ Signal)	C_O	-	22 35	- 50	pF

3. Measured under pulse conditions to reduce heating.

MMT05A230T3, MMT05A260T3, MMT05A310T3

Voltage Current Characteristic of TSPD (Bidirectional Device)

Symbol	Parameter
I_{D1}, I_{D2}	Off State Leakage Current
V_{D1}, V_{D2}	Off State Blocking Voltage
V_{BR}	Breakdown Voltage
V_{BO}	Breakover Voltage
I_{BO}	Breakover Current
I_H	Holding Current
V_{TM}	On State Voltage

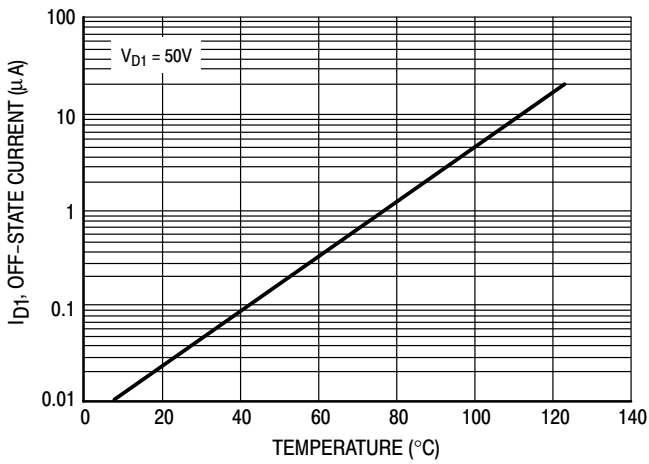
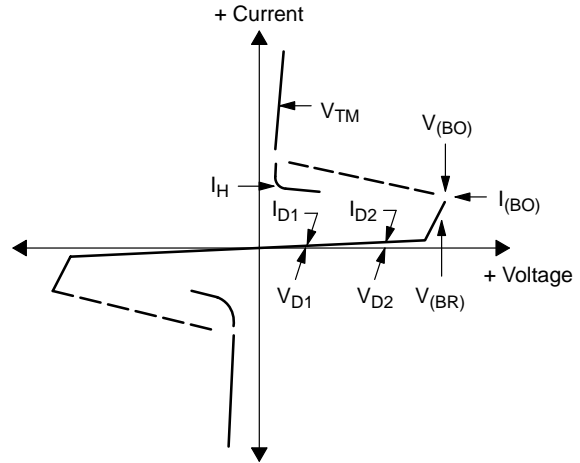

Figure 1. Off-State Current versus Temperature

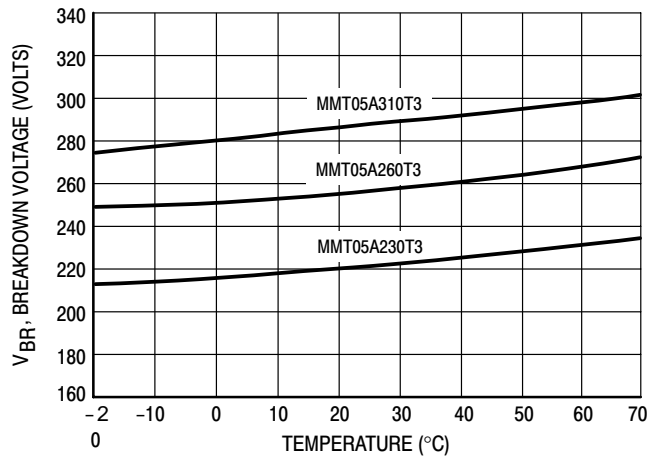

Figure 2. Typical Breakdown Voltage versus Temperature

MMT05A230T3, MMT05A260T3, MMT05A310T3

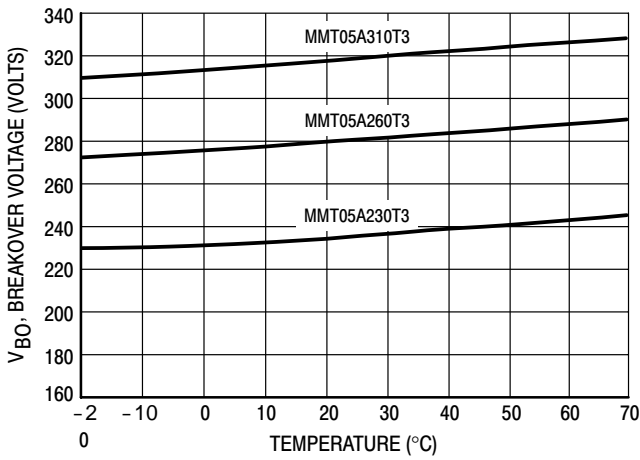

Figure 3. Typical Breakover Voltage versus Temperature

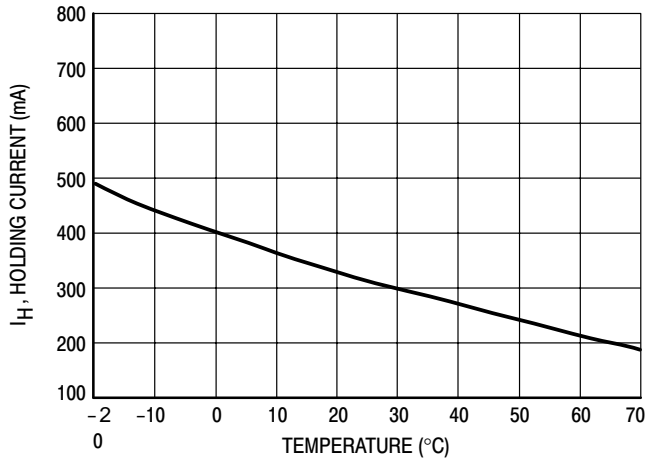

Figure 4. Typical Holding Current versus Temperature

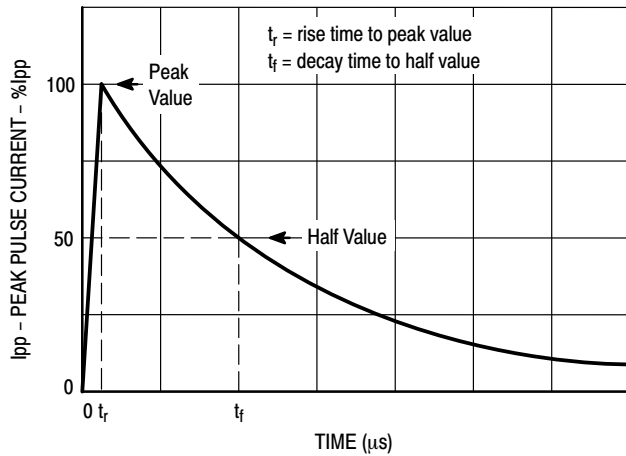

Figure 5. Exponential Decay Pulse Waveform

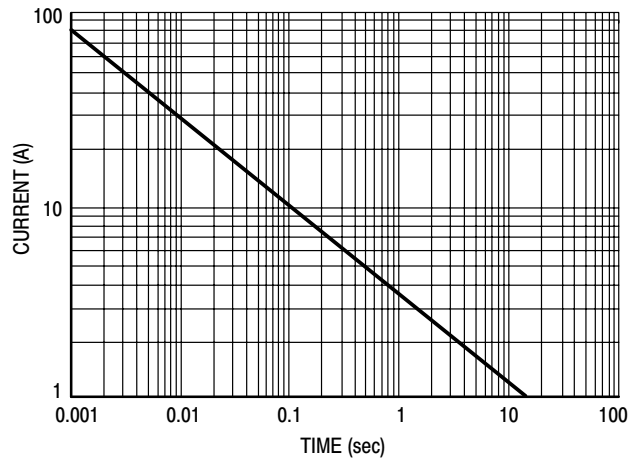
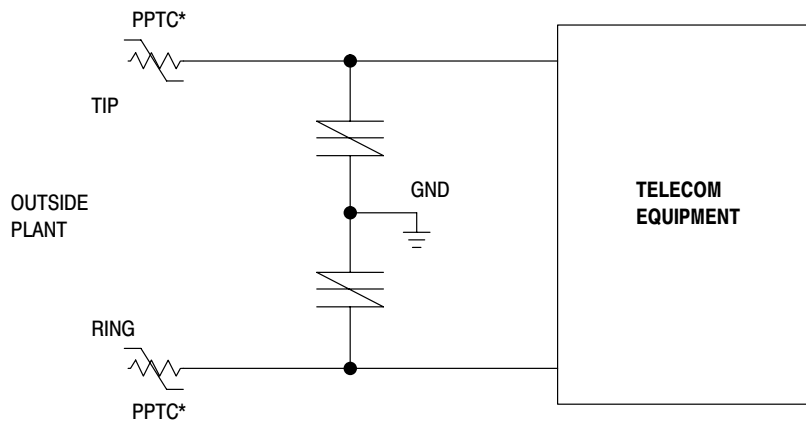
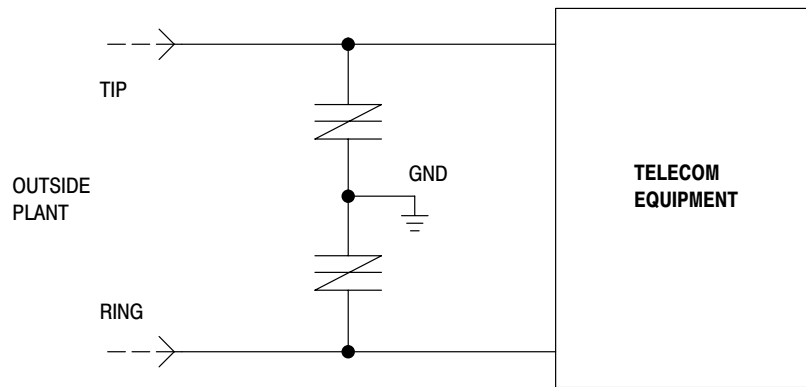
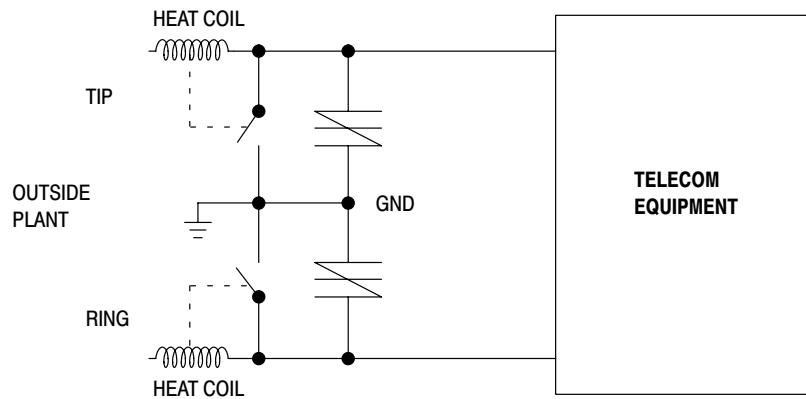

Figure 6. Peak Surge On-State Current versus Surge Current Duration, Sinusoidal Waveform

MMT05A230T3, MMT05A260T3, MMT05A310T3



*Polymeric PTC (positive temperature coefficient) overcurrent protection device



MMT05A230T3, MMT05A260T3, MMT05A310T3

PACKAGE DIMENSIONS

SMA
CASE 403D-02
ISSUE A

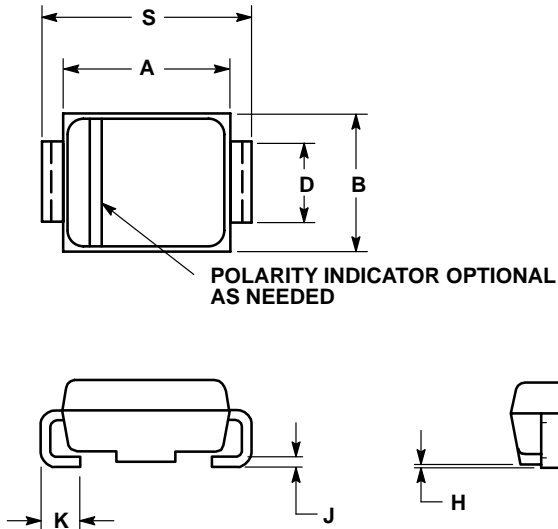

- NOTES:
1. DIMENSIONING AND TOLERANCING PER ANSI Y14.5M, 1982.
 2. CONTROLLING DIMENSION: INCH.
 3. 403D-01 OBSOLETE, NEW STANDARD IS 403D-02.

DIM	INCHES		MILLIMETERS	
	MIN	MAX	MIN	MAX
A	0.160	0.180	4.06	4.57
B	0.090	0.115	2.29	2.92
C	0.075	0.095	1.91	2.41
D	0.050	0.064	1.27	1.63
H	0.002	0.006	0.05	0.15
J	0.006	0.016	0.15	0.41
K	0.030	0.060	0.76	1.52
S	0.190	0.220	4.83	5.59

SOLDERING FOOTPRINT*

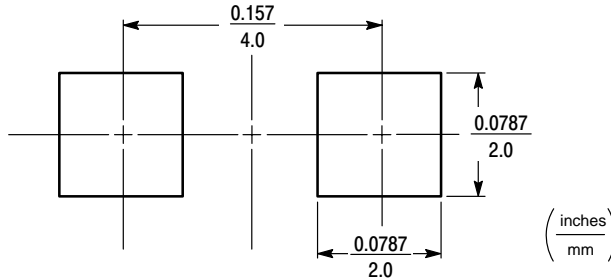

*For additional information on our Pb-Free strategy and soldering details, please download the ON Semiconductor Soldering and Mounting Techniques Reference Manual, SOLDERRM/D.

ON Semiconductor and  are registered trademarks of Semiconductor Components Industries, LLC (SCILLC). SCILLC reserves the right to make changes without further notice to any products herein. SCILLC makes no warranty, representation or guarantee regarding the suitability of its products for any particular purpose, nor does SCILLC assume any liability arising out of the application or use of any product or circuit, and specifically disclaims any and all liability, including without limitation special, consequential or incidental damages. "Typical" parameters which may be provided in SCILLC data sheets and/or specifications can and do vary in different applications and actual performance may vary over time. All operating parameters, including "Typicals" must be validated for each customer application by customer's technical experts. SCILLC does not convey any license under its patent rights nor the rights of others. SCILLC products are not designed, intended, or authorized for use as components in systems intended for surgical implant into the body, or other applications intended to support or sustain life, or for any other application in which the failure of the SCILLC product could create a situation where personal injury or death may occur. Should Buyer purchase or use SCILLC products for any such unintended or unauthorized application, Buyer shall indemnify and hold SCILLC and its officers, employees, subsidiaries, affiliates, and distributors harmless against all claims, costs, damages, and expenses, and reasonable attorney fees arising out of, directly or indirectly, any claim of personal injury or death associated with such unintended or unauthorized use, even if such claim alleges that SCILLC was negligent regarding the design or manufacture of the part. SCILLC is an Equal Opportunity/Affirmative Action Employer. This literature is subject to all applicable copyright laws and is not for resale in any manner.

PUBLICATION ORDERING INFORMATION

LITERATURE FULFILLMENT:

Literature Distribution Center for ON Semiconductor
P.O. Box 5163, Denver, Colorado 80217 USA

Phone: 303-675-2175 or 800-344-3860 Toll Free USA/Canada

Fax: 303-675-2176 or 800-344-3867 Toll Free USA/Canada

Email: orderlit@onsemi.com

N. American Technical Support: 800-282-9855 Toll Free
USA/Canada

Japan: ON Semiconductor, Japan Customer Focus Center

2-9-1 Kamimeguro, Meguro-ku, Tokyo, Japan 153-0051

Phone: 81-3-5773-3850

ON Semiconductor Website: <http://onsemi.com>

Order Literature: <http://www.onsemi.com/litorder>

For additional information, please contact your
local Sales Representative.

MMT05A230T3/D

Looking for pricing, stock, or lifecycle information?

Click below to explore more details on WIN SOURCE:

 [View MMT05A310T3G on WIN SOURCE](#)

 [ON Semiconductor](#) Information

Optimize Your Supply Chain with WIN SOURCE Solutions

-  Global Sourcing Solution
-  Obsolete Management
-  Cost Control Management
-  Shortage Management
-  Alternative Solution
-  Excess Inventory Management