

# MMBZxVCL; MMBZxVDL series

Double ESD protection diodes for transient overvoltage suppression

Rev. 01 — 3 September 2008

Product data sheet

## 1. Product profile

### 1.1 General description

Unidirectional double ElectroStatic Discharge (ESD) protection diodes in a common cathode configuration, encapsulated in a SOT23 (TO-236AB) small Surface-Mounted Device (SMD) plastic package. The devices are designed for ESD and transient overvoltage protection of up to two signal lines.

Table 1. Product overview

Type number <sup>[1]</sup>	Package		Configuration
	NXP	JEDEC	
MMBZ12VDL	SOT23	TO-236AB	dual common cathode
MMBZ15VDL			
MMBZ18VCL			
MMBZ20VCL			
MMBZ27VCL			
MMBZ33VCL			

[1] All types available as /DG halogen-free version.

### 1.2 Features

- Unidirectional ESD protection of two lines
- Bidirectional ESD protection of one line
- Low diode capacitance:  $C_d \leq 140$  pF
- Rated peak pulse power:  $P_{PPM} \leq 40$  W
- Ultra low leakage current:  $I_{RM} \leq 5$  nA
- ESD protection up to 30 kV (contact discharge)
- IEC 61000-4-2; level 4 (ESD)
- IEC 61643-321
- AEC-Q101 qualified

### 1.3 Applications

- Computers and peripherals
- Audio and video equipment
- Cellular handsets and accessories
- Automotive electronic control units
- Portable electronics

## 1.4 Quick reference data

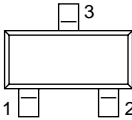
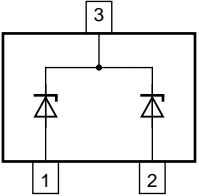
**Table 2. Quick reference data**

$T_{amb} = 25\text{ }^{\circ}\text{C}$  unless otherwise specified.

Symbol	Parameter	Conditions	Min	Typ	Max	Unit
<b>Per diode</b>						
$V_{RWM}$	reverse standoff voltage					
	MMBZ12VDL MMBZ12VDL/DG		-	-	8.5	V
	MMBZ15VDL MMBZ15VDL/DG		-	-	12.8	V
	MMBZ18VCL MMBZ18VCL/DG		-	-	14.5	V
	MMBZ20VCL MMBZ20VCL/DG		-	-	17	V
	MMBZ27VCL MMBZ27VCL/DG		-	-	22	V
	MMBZ33VCL MMBZ33VCL/DG		-	-	26	V
	$C_d$	diode capacitance	$f = 1\text{ MHz}; V_R = 0\text{ V}$			
MMBZ12VDL MMBZ12VDL/DG			-	110	140	pF
MMBZ15VDL MMBZ15VDL/DG			-	85	105	pF
MMBZ18VCL MMBZ18VCL/DG			-	70	90	pF
MMBZ20VCL MMBZ20VCL/DG			-	65	80	pF
MMBZ27VCL MMBZ27VCL/DG			-	48	60	pF
MMBZ33VCL MMBZ33VCL/DG			-	45	55	pF

## 2. Pinning information

**Table 3. Pinning**

Pin	Description	Simplified outline	Graphic symbol
1	anode (diode 1)		 <p style="text-align: right; font-size: small;">006aaa150</p>
2	anode (diode 2)		
3	common cathode		

### 3. Ordering information

Table 4. Ordering information

Type number	Package		
	Name	Description	Version
MMBZ12VDL	-	plastic surface-mounted package; 3 leads	SOT23
MMBZ15VDL			
MMBZ18VCL			
MMBZ20VCL			
MMBZ27VCL			
MMBZ33VCL			
MMBZ12VDL/DG	-	plastic surface-mounted package; 3 leads	SOT23
MMBZ15VDL/DG			
MMBZ18VCL/DG			
MMBZ20VCL/DG			
MMBZ27VCL/DG			
MMBZ33VCL/DG			

### 4. Marking

Table 5. Marking codes

Type number	Marking code <sup>[1]</sup>	Type number	Marking code <sup>[1]</sup>
MMBZ12VDL	*MA	MMBZ12VDL/DG	TJ*
MMBZ15VDL	*MB	MMBZ15VDL/DG	TL*
MMBZ18VCL	*MC	MMBZ18VCL/DG	TN*
MMBZ20VCL	*MD	MMBZ20VCL/DG	TQ*
MMBZ27VCL	*ME	MMBZ27VCL/DG	TS*
MMBZ33VCL	*MF	MMBZ33VCL/DG	TU*

- [1] \* = -: made in Hong Kong  
 \* = p: made in Hong Kong  
 \* = t: made in Malaysia  
 \* = W: made in China

## 5. Limiting values

**Table 6. Limiting values**

In accordance with the Absolute Maximum Rating System (IEC 60134).

Symbol	Parameter	Conditions	Min	Max	Unit
<b>Per diode</b>					
$P_{PPM}$	rated peak pulse power	$t_p = 10/1000 \mu s$	[1][2] -	40	W
$I_{PPM}$	rated peak pulse current	$t_p = 10/1000 \mu s$	[1][2]		
	MMBZ12VDL MMBZ12VDL/DG		-	2.35	A
	MMBZ15VDL MMBZ15VDL/DG		-	1.9	A
	MMBZ18VCL MMBZ18VCL/DG		-	1.6	A
	MMBZ20VCL MMBZ20VCL/DG		-	1.4	A
	MMBZ27VCL MMBZ27VCL/DG		-	1	A
	MMBZ33VCL MMBZ33VCL/DG		-	0.87	A
<b>Per device</b>					
$P_{tot}$	total power dissipation	$T_{amb} \leq 25 \text{ }^\circ\text{C}$	[3] -	350	mW
			[4] -	440	mW
$T_j$	junction temperature		-	150	$^\circ\text{C}$
$T_{amb}$	ambient temperature		-55	+150	$^\circ\text{C}$
$T_{stg}$	storage temperature		-65	+150	$^\circ\text{C}$

[1] In accordance with IEC 61643-321 (10/1000  $\mu s$  current waveform).

[2] Measured from pin 1 or 2 to pin 3.

[3] Device mounted on an FR4 Printed-Circuit Board (PCB), single-sided copper, tin-plated and standard footprint.

[4] Device mounted on an FR4 PCB, single-sided copper, tin-plated, mounting pad for cathode 1 cm<sup>2</sup>.

**Table 7. ESD maximum ratings**

$T_{amb} = 25 \text{ }^\circ\text{C}$  unless otherwise specified.

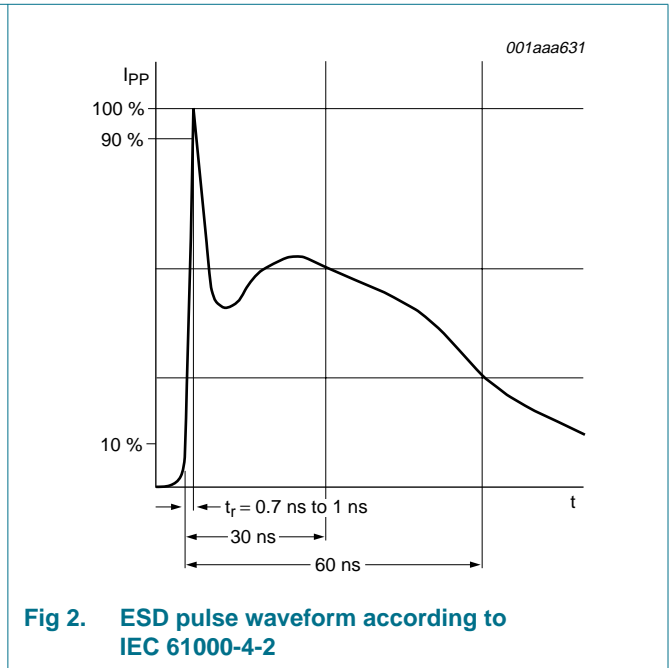
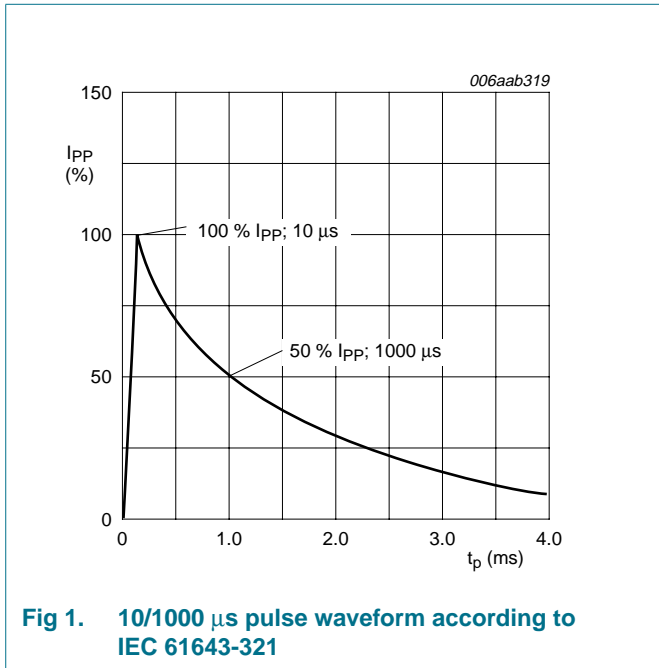
Symbol	Parameter	Conditions	Min	Max	Unit
<b>Per diode</b>					
$V_{ESD}$	electrostatic discharge voltage		[1][2]		
		IEC 61000-4-2 (contact discharge)	-	30	kV
		machine model	-	2	kV

[1] Device stressed with ten non-repetitive ESD pulses.

[2] Measured from pin 1 or 2 to pin 3.

**Table 8. ESD standards compliance**

Standard	Conditions
<b>Per diode</b>	
IEC 61000-4-2; level 4 (ESD)	> 15 kV (air); > 8 kV (contact)
MIL-STD-883; class 3 (human body model)	> 8 kV



## 6. Thermal characteristics

**Table 9. Thermal characteristics**

Symbol	Parameter	Conditions	Min	Typ	Max	Unit
<b>Per device</b>						
$R_{th(j-a)}$	thermal resistance from junction to ambient	in free air	[1] -	-	350	K/W
			[2] -	-	280	K/W
$R_{th(j-sp)}$	thermal resistance from junction to solder point		[3] -	-	60	K/W

[1] Device mounted on an FR4 PCB, single-sided copper, tin-plated and standard footprint.

[2] Device mounted on an FR4 PCB, single-sided copper, tin-plated, mounting pad for cathode 1 cm<sup>2</sup>.

[3] Soldering point at pin 3.

## 7. Characteristics

**Table 10. Characteristics**
*T<sub>amb</sub> = 25 °C unless otherwise specified.*

Symbol	Parameter	Conditions	Min	Typ	Max	Unit
<b>Per diode</b>						
V <sub>F</sub>	forward voltage					
	MMBZ12VDL MMBZ12VDL/DG	I <sub>F</sub> = 10 mA	-	-	0.9	V
	MMBZ15VDL MMBZ15VDL/DG	I <sub>F</sub> = 10 mA	-	-	0.9	V
	MMBZ18VCL MMBZ18VCL/DG	I <sub>F</sub> = 10 mA	-	-	0.9	V
	MMBZ20VCL MMBZ20VCL/DG	I <sub>F</sub> = 10 mA	-	-	0.9	V
	MMBZ27VCL MMBZ27VCL/DG	I <sub>F</sub> = 200 mA	-	-	1.1	V
	MMBZ33VCL MMBZ33VCL/DG	I <sub>F</sub> = 10 mA	-	-	0.9	V
V <sub>RWM</sub>	reverse standoff voltage					
	MMBZ12VDL MMBZ12VDL/DG		-	-	8.5	V
	MMBZ15VDL MMBZ15VDL/DG		-	-	12.8	V
	MMBZ18VCL MMBZ18VCL/DG		-	-	14.5	V
	MMBZ20VCL MMBZ20VCL/DG		-	-	17	V
	MMBZ27VCL MMBZ27VCL/DG		-	-	22	V
	MMBZ33VCL MMBZ33VCL/DG		-	-	26	V
I <sub>RM</sub>	reverse leakage current					
	MMBZ12VDL MMBZ12VDL/DG	V <sub>RWM</sub> = 8.5 V	-	0.1	5	nA
	MMBZ15VDL MMBZ15VDL/DG	V <sub>RWM</sub> = 12.8 V	-	0.1	5	nA
	MMBZ18VCL MMBZ18VCL/DG	V <sub>RWM</sub> = 14.5 V	-	0.1	5	nA
	MMBZ20VCL MMBZ20VCL/DG	V <sub>RWM</sub> = 17 V	-	0.1	5	nA
	MMBZ27VCL MMBZ27VCL/DG	V <sub>RWM</sub> = 22 V	-	0.1	5	nA
	MMBZ33VCL MMBZ33VCL/DG	V <sub>RWM</sub> = 26 V	-	0.1	5	nA

Table 10. Characteristics ...continued

 $T_{amb} = 25^{\circ}\text{C}$  unless otherwise specified.

Symbol	Parameter	Conditions	Min	Typ	Max	Unit
$V_{BR}$	breakdown voltage	$I_R = 1\text{ mA}$				
	MMBZ12VDL MMBZ12VDL/DG		11.4	12	12.6	V
	MMBZ15VDL MMBZ15VDL/DG		14.3	15	15.8	V
	MMBZ18VCL MMBZ18VCL/DG		17.1	18	18.9	V
	MMBZ20VCL MMBZ20VCL/DG		19	20	21	V
	MMBZ27VCL MMBZ27VCL/DG		25.65	27	28.35	V
	MMBZ33VCL MMBZ33VCL/DG		31.35	33	34.65	V
$C_d$	diode capacitance	$f = 1\text{ MHz}; V_R = 0\text{ V}$				
	MMBZ12VDL MMBZ12VDL/DG		-	110	140	pF
	MMBZ15VDL MMBZ15VDL/DG		-	85	105	pF
	MMBZ18VCL MMBZ18VCL/DG		-	70	90	pF
	MMBZ20VCL MMBZ20VCL/DG		-	65	80	pF
	MMBZ27VCL MMBZ27VCL/DG		-	48	60	pF
	MMBZ33VCL MMBZ33VCL/DG		-	45	55	pF
$V_{CL}$	clamping voltage					<a href="#">[1][2]</a>
	MMBZ12VDL MMBZ12VDL/DG	$I_{PPM} = 2.35\text{ A}$	-	-	17	V
	MMBZ15VDL MMBZ15VDL/DG	$I_{PPM} = 1.9\text{ A}$	-	-	21.2	V
	MMBZ18VCL MMBZ18VCL/DG	$I_{PPM} = 1.6\text{ A}$	-	-	25	V
	MMBZ20VCL MMBZ20VCL/DG	$I_{PPM} = 1.4\text{ A}$	-	-	28	V
	MMBZ27VCL MMBZ27VCL/DG	$I_{PPM} = 1\text{ A}$	-	-	38	V
	MMBZ33VCL MMBZ33VCL/DG	$I_{PPM} = 0.87\text{ A}$	-	-	46	V

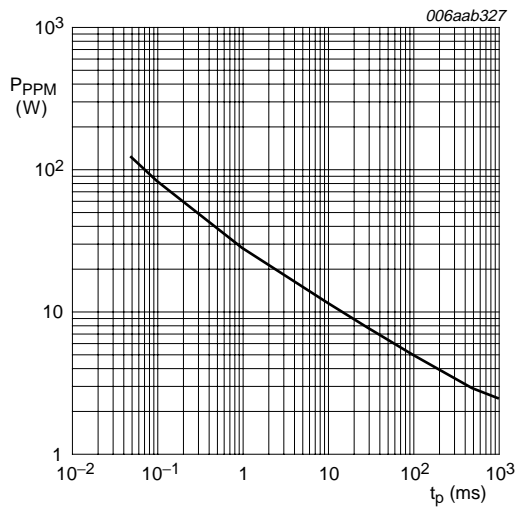
**Table 10. Characteristics ...continued**

$T_{amb} = 25^{\circ}C$  unless otherwise specified.

Symbol	Parameter	Conditions	Min	Typ	Max	Unit
$S_Z$	temperature coefficient	$I_Z = 1\text{ mA}$				
	MMBZ12VDL MMBZ12VDL/DG		-	8.1	-	mV/K
	MMBZ15VDL MMBZ15VDL/DG		-	11	-	mV/K
	MMBZ18VCL MMBZ18VCL/DG		-	14	-	mV/K
	MMBZ20VCL MMBZ20VCL/DG		-	15.8	-	mV/K
	MMBZ27VCL MMBZ27VCL/DG		-	23	-	mV/K
	MMBZ33VCL MMBZ33VCL/DG		-	29.4	-	mV/K

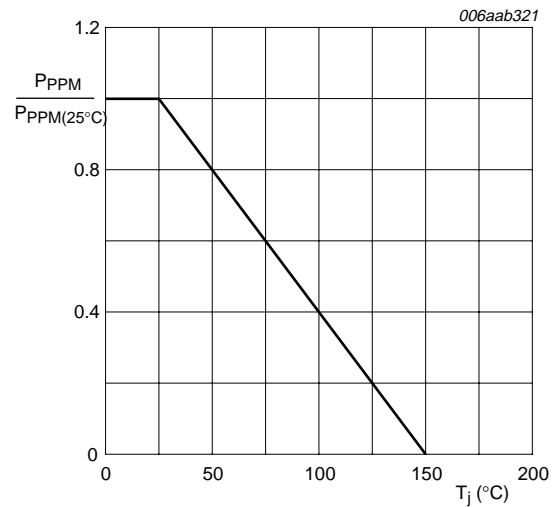
[1] In accordance with IEC 61643-321 (10/1000  $\mu\text{s}$  current waveform).

[2] Measured from pin 1 or 2 to pin 3.

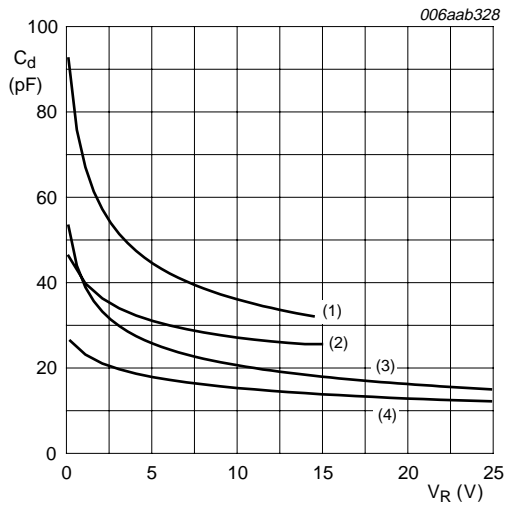


MMBZ27VCL: unidirectional and bidirectional  
 $T_{amb} = 25^{\circ}C$

**Fig 3. Rated peak pulse power as a function of exponential pulse duration (rectangular waveform); typical values**

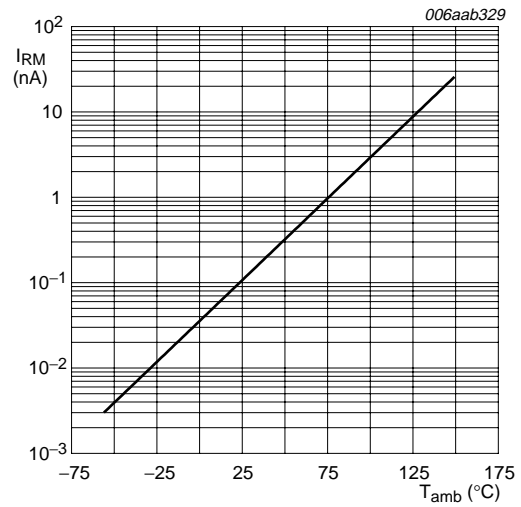


**Fig 4. Relative variation of rated peak pulse power as a function of junction temperature; typical values**



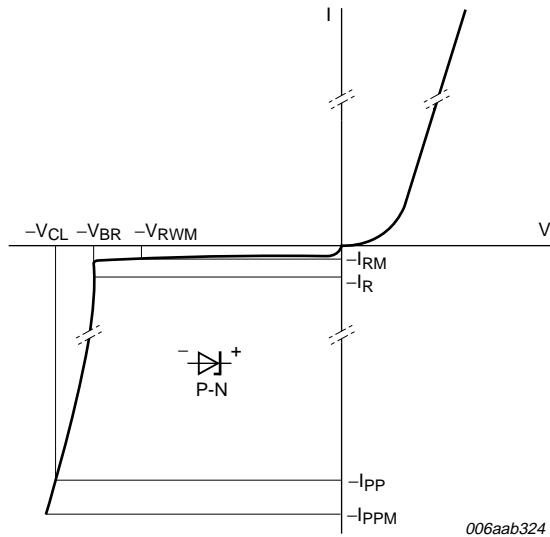
$f = 1 \text{ MHz}; T_{\text{amb}} = 25 \text{ }^\circ\text{C}$   
 (1) MMBZ15VDL: unidirectional  
 (2) MMBZ15VDL: bidirectional  
 (3) MMBZ27VCL: unidirectional  
 (4) MMBZ27VCL: bidirectional

**Fig 5. Diode capacitance as a function of reverse voltage; typical values**

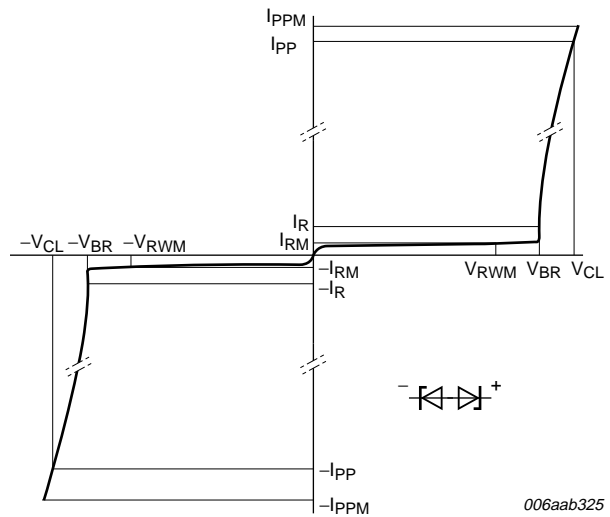


MMBZ27VCL:  $V_{\text{RWM}} = 22 \text{ V}$

**Fig 6. Reverse leakage current as a function of junction temperature; typical values**



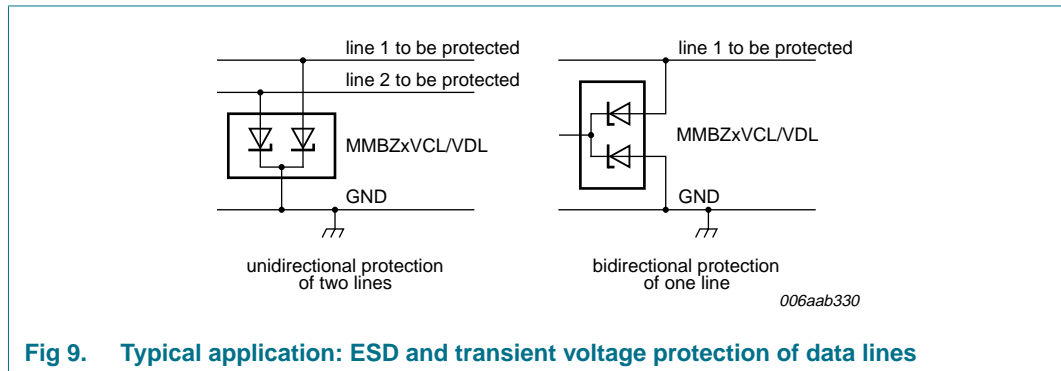
**Fig 7. V-I characteristics for a unidirectional ESD protection diode**



**Fig 8. V-I characteristics for a bidirectional ESD protection diode**

## 8. Application information

The MMBZxVCL series and the MMBZxVDL series are designed for the protection of up to two unidirectional data or signal lines from the damage caused by ESD and surge pulses. The devices may be used on lines where the signal polarities are either positive or negative with respect to ground. The devices provide a surge capability of 40 W per line for a 10/1000  $\mu$ s waveform.



**Fig 9. Typical application: ESD and transient voltage protection of data lines**

### Circuit board layout and protection device placement

Circuit board layout is critical for the suppression of ESD, Electrical Fast Transient (EFT) and surge transients. The following guidelines are recommended:

1. Place the devices as close to the input terminal or connector as possible.
2. The path length between the device and the protected line should be minimized.
3. Keep parallel signal paths to a minimum.
4. Avoid running protected conductors in parallel with unprotected conductors.
5. Minimize all Printed-Circuit Board (PCB) conductive loops including power and ground loops.
6. Minimize the length of the transient return path to ground.
7. Avoid using shared transient return paths to a common ground point.
8. Ground planes should be used whenever possible. For multilayer PCBs, use ground vias.

## 9. Test information

### 9.1 Quality information

This product has been qualified in accordance with the Automotive Electronics Council (AEC) standard *Q101 - Stress test qualification for discrete semiconductors*, and is suitable for use in automotive applications.



## 12. Soldering

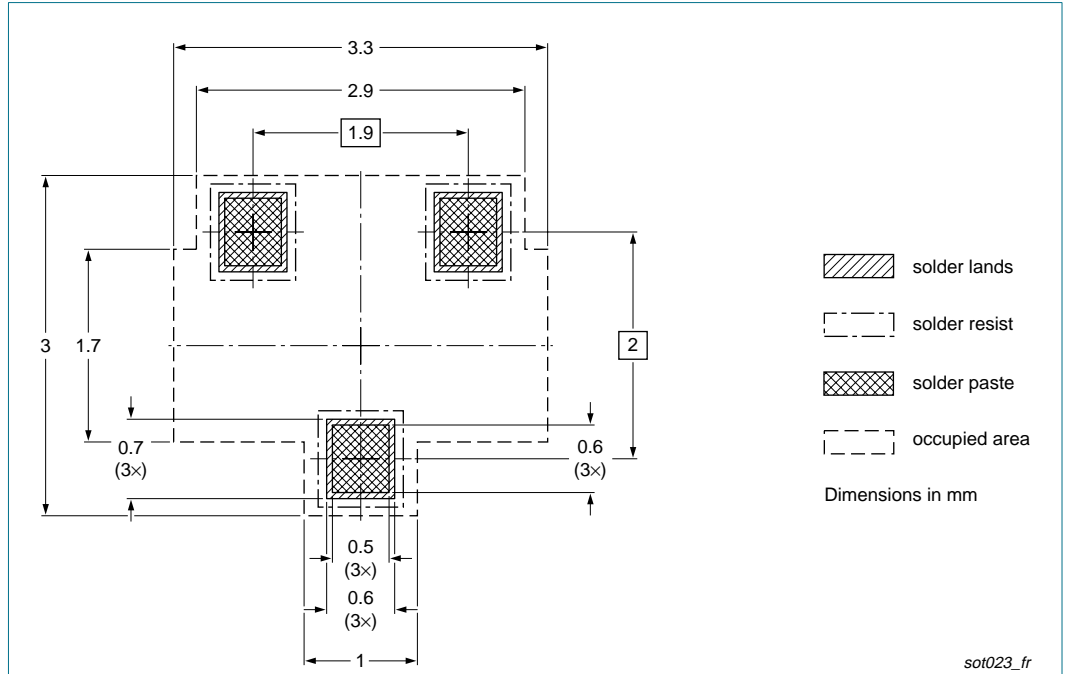


Fig 11. Reflow soldering footprint SOT23 (TO-236AB)

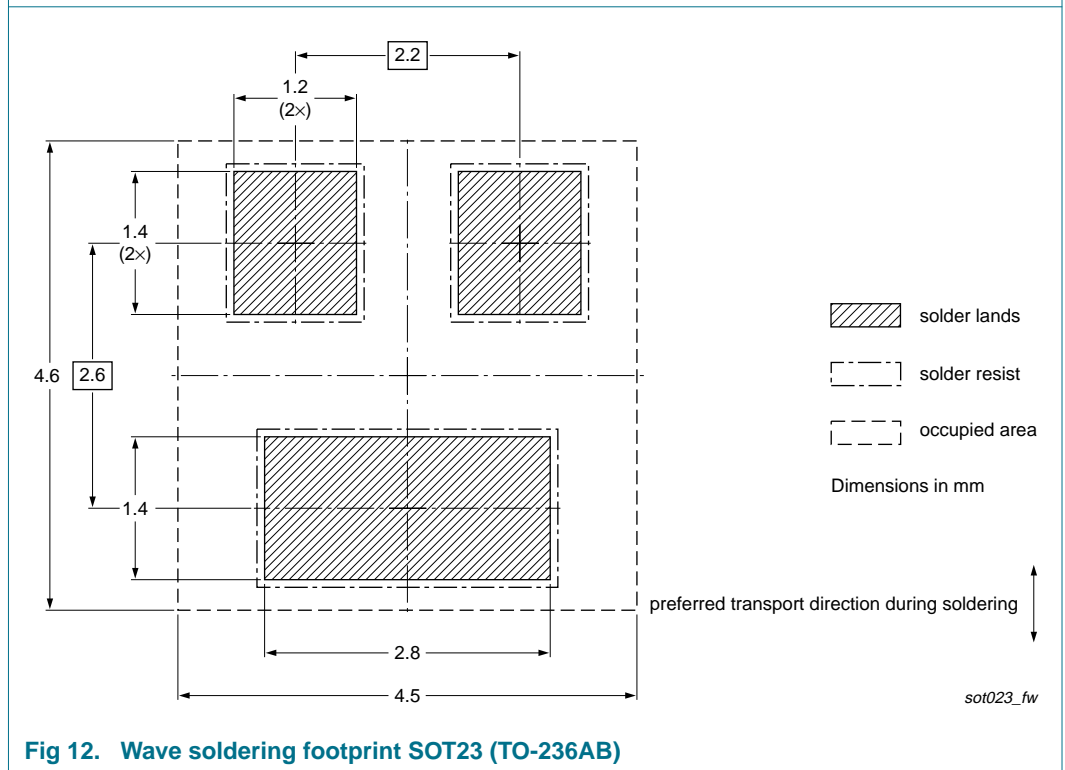


Fig 12. Wave soldering footprint SOT23 (TO-236AB)

## 13. Revision history

---

**Table 12. Revision history**

Document ID	Release date	Data sheet status	Change notice	Supersedes
MMBZXVCL_MMBZXVDL_SER_1	20080903	Product data sheet	-	-

## 14. Legal information

### 14.1 Data sheet status

Document status <sup>[1][2]</sup>	Product status <sup>[3]</sup>	Definition
Objective [short] data sheet	Development	This document contains data from the objective specification for product development.
Preliminary [short] data sheet	Qualification	This document contains data from the preliminary specification.
Product [short] data sheet	Production	This document contains the product specification.

[1] Please consult the most recently issued document before initiating or completing a design.

[2] The term 'short data sheet' is explained in section "Definitions".

[3] The product status of device(s) described in this document may have changed since this document was published and may differ in case of multiple devices. The latest product status information is available on the Internet at URL <http://www.nxp.com>.

### 14.2 Definitions

**Draft** — The document is a draft version only. The content is still under internal review and subject to formal approval, which may result in modifications or additions. NXP Semiconductors does not give any representations or warranties as to the accuracy or completeness of information included herein and shall have no liability for the consequences of use of such information.

**Short data sheet** — A short data sheet is an extract from a full data sheet with the same product type number(s) and title. A short data sheet is intended for quick reference only and should not be relied upon to contain detailed and full information. For detailed and full information see the relevant full data sheet, which is available on request via the local NXP Semiconductors sales office. In case of any inconsistency or conflict with the short data sheet, the full data sheet shall prevail.

### 14.3 Disclaimers

**General** — Information in this document is believed to be accurate and reliable. However, NXP Semiconductors does not give any representations or warranties, expressed or implied, as to the accuracy or completeness of such information and shall have no liability for the consequences of use of such information.

**Right to make changes** — NXP Semiconductors reserves the right to make changes to information published in this document, including without limitation specifications and product descriptions, at any time and without notice. This document supersedes and replaces all information supplied prior to the publication hereof.

**Suitability for use** — NXP Semiconductors products are not designed, authorized or warranted to be suitable for use in medical, military, aircraft, space or life support equipment, nor in applications where failure or malfunction of an NXP Semiconductors product can reasonably be expected to result in personal injury, death or severe property or environmental damage. NXP Semiconductors accepts no liability for inclusion and/or use of NXP Semiconductors products in such equipment or applications and therefore such inclusion and/or use is at the customer's own risk.

**Applications** — Applications that are described herein for any of these products are for illustrative purposes only. NXP Semiconductors makes no representation or warranty that such applications will be suitable for the specified use without further testing or modification.

**Limiting values** — Stress above one or more limiting values (as defined in the Absolute Maximum Ratings System of IEC 60134) may cause permanent damage to the device. Limiting values are stress ratings only and operation of the device at these or any other conditions above those given in the Characteristics sections of this document is not implied. Exposure to limiting values for extended periods may affect device reliability.

**Terms and conditions of sale** — NXP Semiconductors products are sold subject to the general terms and conditions of commercial sale, as published at <http://www.nxp.com/profile/terms>, including those pertaining to warranty, intellectual property rights infringement and limitation of liability, unless explicitly otherwise agreed to in writing by NXP Semiconductors. In case of any inconsistency or conflict between information in this document and such terms and conditions, the latter will prevail.

**No offer to sell or license** — Nothing in this document may be interpreted or construed as an offer to sell products that is open for acceptance or the grant, conveyance or implication of any license under any copyrights, patents or other industrial or intellectual property rights.

**Quick reference data** — The Quick reference data is an extract of the product data given in the Limiting values and Characteristics sections of this document, and as such is not complete, exhaustive or legally binding.

**ESD protection devices** — These products are only intended for protection against ElectroStatic Discharge (ESD) pulses and are not intended for any other usage including, without limitation, voltage regulation applications. NXP Semiconductors accepts no liability for use in such applications and therefore such use is at the customer's own risk.

### 14.4 Trademarks

Notice: All referenced brands, product names, service names and trademarks are the property of their respective owners.

## 15. Contact information

For more information, please visit: <http://www.nxp.com>

For sales office addresses, please send an email to: [salesaddresses@nxp.com](mailto:salesaddresses@nxp.com)

## 16. Contents

<b>1</b>	<b>Product profile</b> .....	<b>1</b>
1.1	General description .....	1
1.2	Features .....	1
1.3	Applications .....	1
1.4	Quick reference data .....	2
<b>2</b>	<b>Pinning information</b> .....	<b>2</b>
<b>3</b>	<b>Ordering information</b> .....	<b>3</b>
<b>4</b>	<b>Marking</b> .....	<b>3</b>
<b>5</b>	<b>Limiting values</b> .....	<b>4</b>
<b>6</b>	<b>Thermal characteristics</b> .....	<b>5</b>
<b>7</b>	<b>Characteristics</b> .....	<b>6</b>
<b>8</b>	<b>Application information</b> .....	<b>10</b>
<b>9</b>	<b>Test information</b> .....	<b>10</b>
9.1	Quality information .....	10
<b>10</b>	<b>Package outline</b> .....	<b>11</b>
<b>11</b>	<b>Packing information</b> .....	<b>11</b>
<b>12</b>	<b>Soldering</b> .....	<b>12</b>
<b>13</b>	<b>Revision history</b> .....	<b>13</b>
<b>14</b>	<b>Legal information</b> .....	<b>14</b>
14.1	Data sheet status .....	14
14.2	Definitions .....	14
14.3	Disclaimers .....	14
14.4	Trademarks .....	14
<b>15</b>	<b>Contact information</b> .....	<b>14</b>
<b>16</b>	<b>Contents</b> .....	<b>15</b>

Please be aware that important notices concerning this document and the product(s) described herein, have been included in section 'Legal information'.



© NXP B.V. 2008.

All rights reserved.

For more information, please visit: <http://www.nxp.com>

For sales office addresses, please send an email to: [salesaddresses@nxp.com](mailto:salesaddresses@nxp.com)

Date of release: 3 September 2008

Document identifier: MMBZXVCL\_MMBZXVDL\_SER\_1

## Looking for pricing, stock, or lifecycle information?

Click below to explore more details on WIN SOURCE:

- ⊖ [View MMBZ20VCL on WIN SOURCE](#)
- ⊖ [NXP / Nexperia Information](#)

## Optimize Your Supply Chain with WIN SOURCE Solutions

- ✓ Global Sourcing Solution
- ✓ Obsolete Management
- ✓ Cost Control Management
- ✓ Shortage Management
- ✓ Alternative Solution
- ✓ Excess Inventory Management