



**THE DATASHEET OF
MLX90217LUA-CAA-000-BU**



Features and Benefits

- Geartooth Sensor
- Zero Speed Detection
- Insensitive to Orientation
- Short Circuit Protection
- Self-Adjusting Magnetic Range
- On-chip 10 bit A/D Converter
- High Speed Operation
- No Chopper Delay

Applications

- Geartooth Sensor
- Speed Sensor
- Camshaft Sensor
- Direction Detection*

*See applications example

Ordering Code

Product Code	Temperature Code	Package Code	Option Code	Packing Form Code
MLX90217	L	UA	CAA-000	BU
MLX90217	L	UA	CCA-000	BU

Legend:

Temperature Code: L for Temperature Range -40°C to 150°C
 Package Code: UA for UA package
 Option Code: AAA-xxx: Die version
 xxx-000: Standard version
 Packing Form: BU for Bulk

Ordering example: MLX90217LUA-CAA-000-BU

Functional Diagram

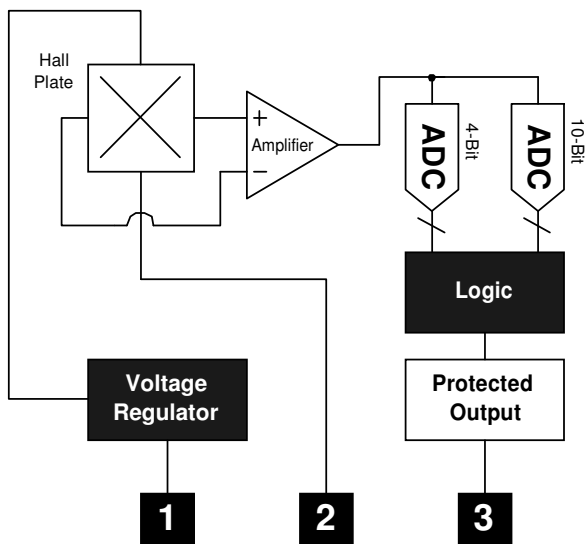

Pin 1 - V_{DD} (Supply)
 Pin 2 - V_{SS} (Ground)
 Pin 3 - Output

Note: Static sensitive device, please observe ESD precautions.

Description

The MLX90217 is a self adjusting digital output rotary position gear tooth sensor designed for use in automotive camshaft sensing as well as other speed sensing applications. It is designed to be used with a bias magnet south facing the back (non-marked) side of the IC. The device has an open collector output which is short circuit protected.

The MLX90217 is a sophisticated IC featuring an on-chip 10-bit A/D Converter and logic that acts as a digital sample and hold circuit. A separate 4-bit A/D converter provides a fixed hysteresis. The 90217 does not have a chopper delay. The 90217 uses a single Hall plate which is immune to rotary alignment problems. The bias magnet can be from 50 to 400mT.

As the signal is sampled, the logic recognizes an increasing or decreasing flux density. The output will turn on (B_{OP}) after the flux has reached its peak and decreased by an amount equal to the hysteresis. Similarly the output will turn off (B_{RP}) after the flux has reached its minimum value and increased by an amount equal to the hysteresis.

MLX90217 Electrical Specifications

DC Operating Parameters $T_A = -40^{\circ}\text{C}$ to 150°C , $V_{DD} = 3.5\text{V}$ to 24V (unless otherwise specified).

Parameter	Symbol	Test Conditions	Min	Typ	Max	Units
Supply Voltage	V_{DD}	Operating	3.5	-	24	V
Supply Current	I_{DD}	$V_{DD} = 12\text{V}$	1.5	3.0	4.5	mA
Supply Current	I_{DD}	$V_{DD} = 3.5\text{V}$ to 24V	1	-	6	mA
Leakage Current	I_{LEAK}	$V_{OUT} = 3.5\text{V}$ to 24V	-	-	10	μA
Output Current	I_{OUT}	Operating	-	-	25	mA
Output Saturation Voltage	V_{SAT}	$V_{DD} = 12\text{V}$, $I_{OUT} = 25\text{mA}$	-	-	600	mV
Output Short Circuit Current	I_{FAULT}	Fault	50	100	150	mA
Output Short Circuit Shutdown	T_{FAULT}	Fault	100	-	200	S
Clock Frequency	f_{CLK}	Operating	300	500	800	kHz
Output Rise Time	t_r	$V_{DD}=12\text{V}$ $R_1 = 880\Omega$ $C_1 = 20\text{pf}$	-	-	400	nS
Output Fall Time	t_f	$V_{DD}=12\text{V}$ $R_1 = 880\Omega$ $C_1 = 20\text{pf}$	-	-	400	nS
Bandwidth	BW	Operating	-	-	15	kHz
Thermal Resistance	R_{TH}	Operating	-	-	200	$^{\circ}\text{C}/\text{Watt}$

MLX90217 Magnetic Specifications

DC Operating Parameters $T_A = -40^{\circ}\text{C}$ to 150°C , $V_{DD} = 3.5\text{V}$ to 24V (Unless otherwise specified)

Parameter	Symbol	Test Conditions	Min	Typ	Max	Units
Back Bias Range	B_{BIAS}	Operating	-30	-	400	mT
Linear Region		$V_{DD} = 12\text{V}$	50	-	500	mT
Hysteresis	B_{hys}	(CAA-000)	1.8	3.5	10	mT
		(CCA-000)	3.8	5.5	12	mT

Note: 1 mT = 10 Gauss

Performance Graphs

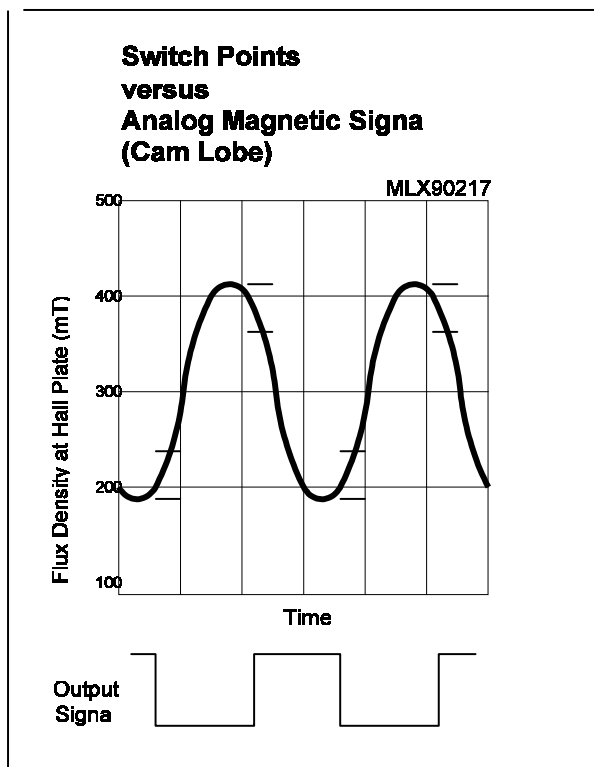
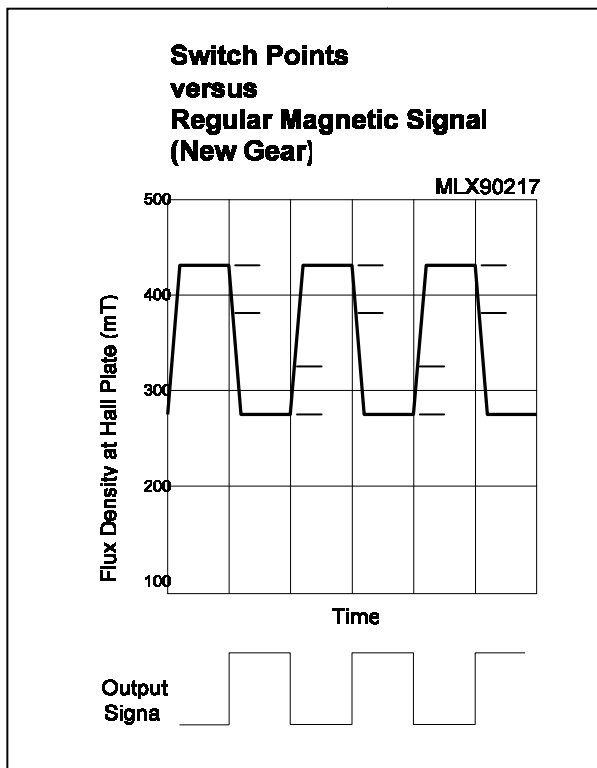
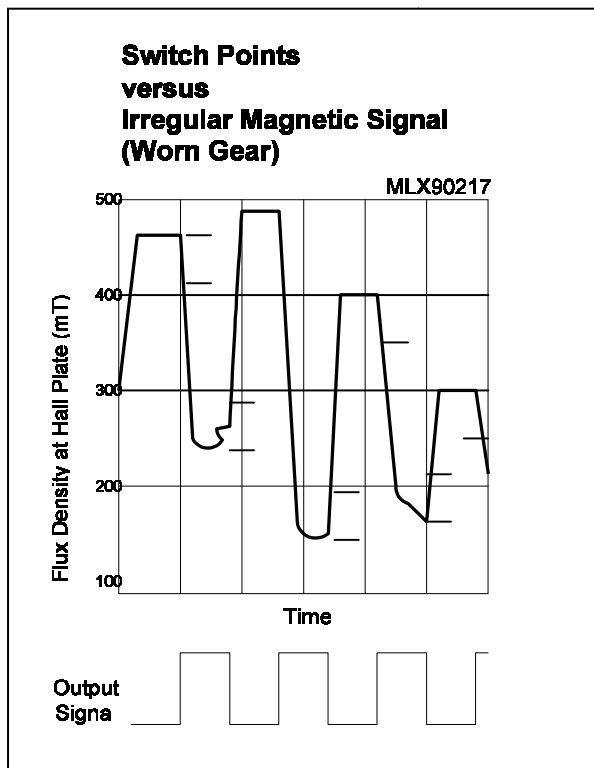

Absolute Maximum Ratings

Supply Voltage (Operating), V_{DD}	30V
Supply Current (Fault), I_{DD}	50mA
Output Current (Fault), I_{OUT}	30mA
Output Current (Fault), I_{fault}	50mA
Output Voltage, V_{OUT}	30V
Power Dissipation, P_D	100mW
Operating Temperature Range, T_A	- 40°C to 150°C
Storage Temperature Range, T_S	- 65°C to 150°C
Maximun Junction Temp, T_J	175°C

Application Notes

Maximum dynamic range is 500 mT. The hysteresis is fixed at 5.0 mT. Best angular accuracy will be obtained when the magnetic circuit provides peak magnetic flux at the chip near the high end of the linear range of 500 mT. EMC protection using external components are recommended. Two possibilities are shown on the following page. Normally the South pole faces the unbranded side of the device. A North pole will enable a test sequence used in factory testing.

Unique Features

The output is reset to the high state at power on (output driver is off) whatever the field is. The output only changes after the first min is detected. The reset state holds no information about the field. If the supply of the chip is raised slowly, the reset state is not stable. This has been observed at 0 field but it should be the same with small and large fields.

Gear tooth sensors often need to be adjusted after the module is assembled to align the magnet with differential Hall plates or orient with teeth. However the MLX90217 is “self adjusting” over a wide range of back bias flux eliminating the need for any trimming in the application. The magnet may be glued to the back surface (non branded side) of the IC using a cyanoacrylate adhesive or suitable epoxy.

Applications Examples

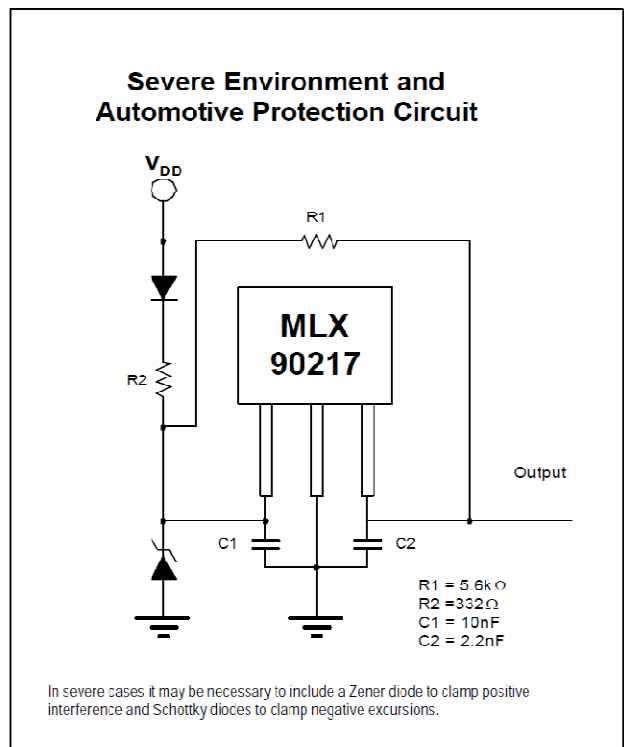
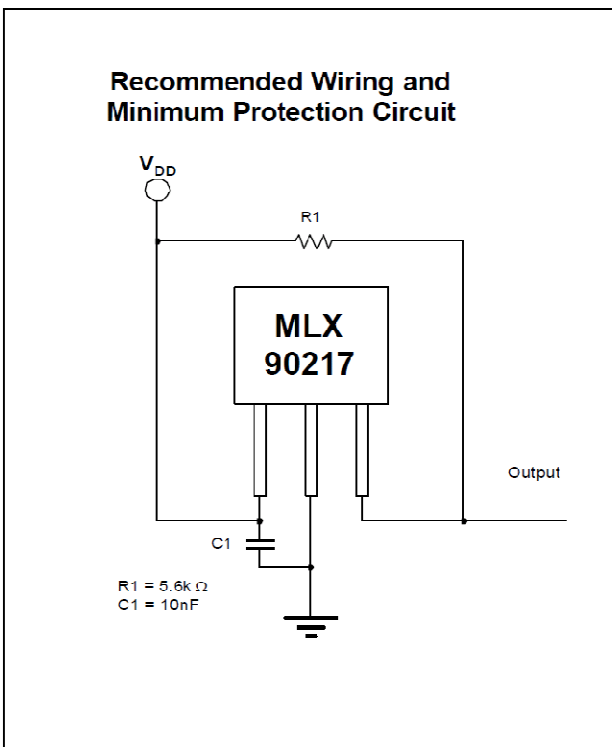
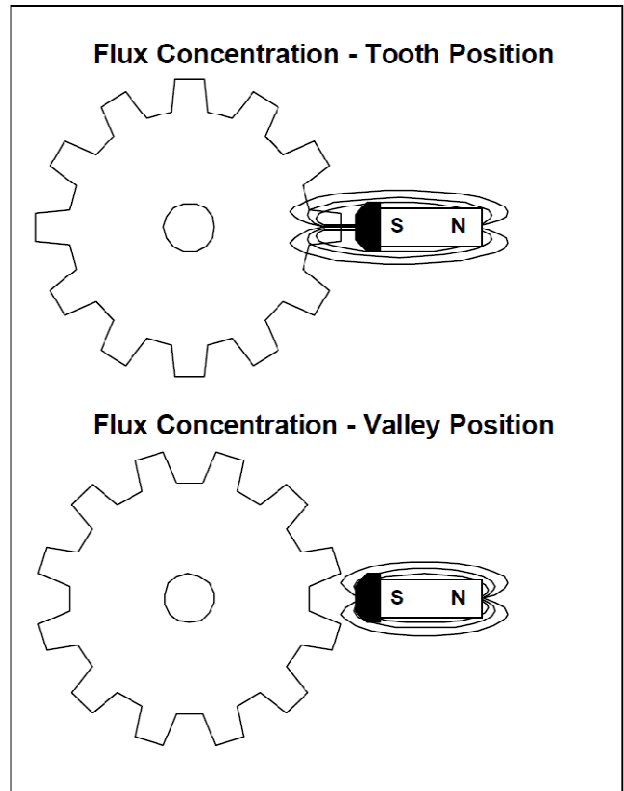
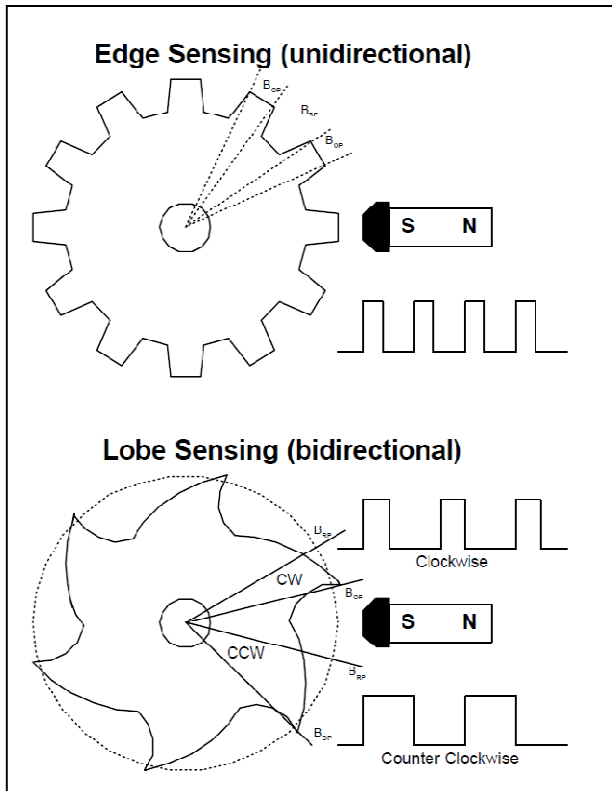

Physical Characteristics

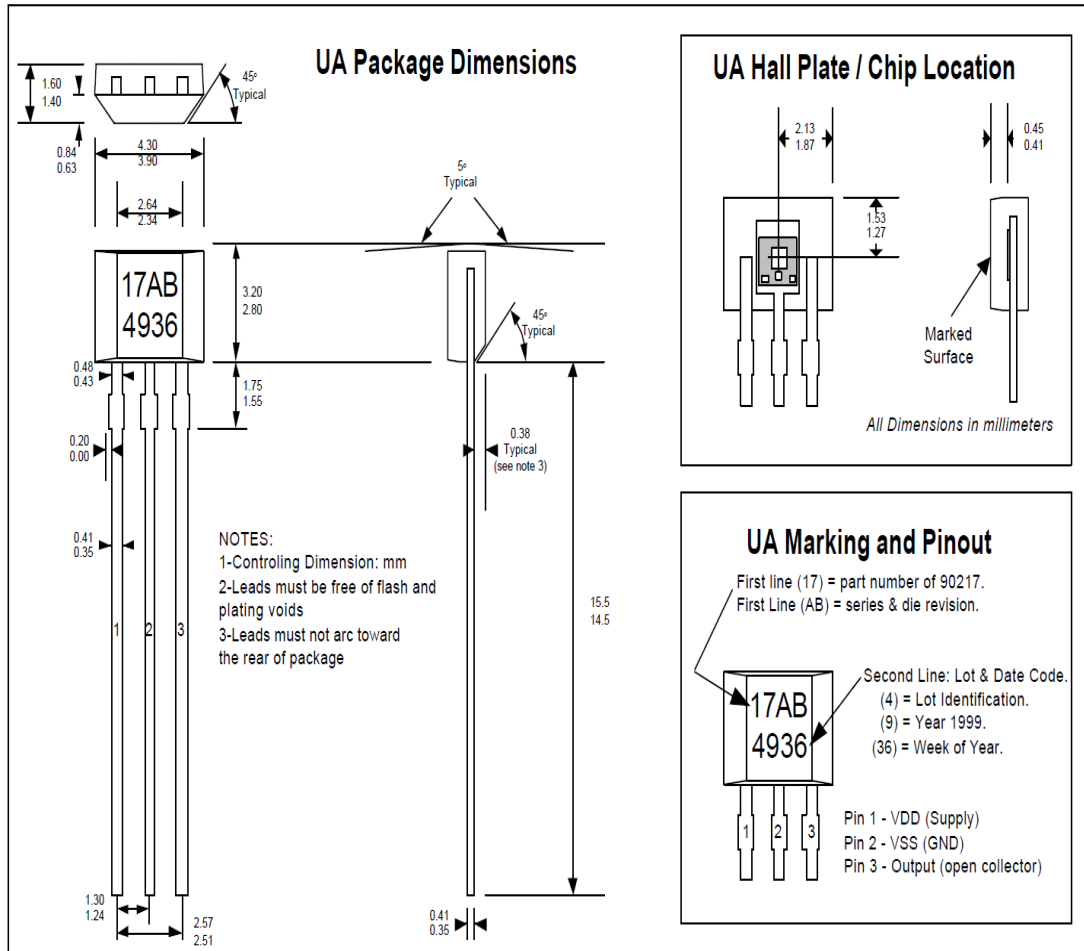

Standard information regarding manufacturability of Melexis products with different soldering processes

Our products are classified and qualified regarding soldering technology, solderability and moisture sensitivity level according to following test methods:

Reflow Soldering SMD's (Surface Mount Devices)

- IPC/JEDEC J-STD-020
Moisture/Reflow Sensitivity Classification for Nonhermetic Solid State Surface Mount Devices (classification reflow profiles according to table 5-2)
- EIA/JEDEC JESD22-A113
Preconditioning of Nonhermetic Surface Mount Devices Prior to Reliability Testing (reflow profiles according to table 2)

Wave Soldering SMD's (Surface Mount Devices) and THD's (Through Hole Devices)

- EN60749-20
Resistance of plastic- encapsulated SMD's to combined effect of moisture and soldering heat
- EIA/JEDEC JESD22-B106 and EN60749-15
Resistance to soldering temperature for through-hole mounted devices

Iron Soldering THD's (Through Hole Devices)

- EN60749-15
Resistance to soldering temperature for through-hole mounted devices

Solderability SMD's (Surface Mount Devices) and THD's (Through Hole Devices)

- EIA/JEDEC JESD22-B102 and EN60749-21
Solderability

For all soldering technologies deviating from above mentioned standard conditions (regarding peak temperature, temperature gradient, temperature profile etc) additional classification and qualification tests have to be agreed upon with Melexis.

The application of Wave Soldering for SMD's is allowed only after consulting Melexis regarding assurance of adhesive strength between device and board.

Melexis is contributing to global environmental conservation by promoting **lead free** solutions. For more information on qualifications of **RoHS** compliant products (RoHS = European directive on the Restriction Of the use of certain Hazardous Substances) please visit the quality page on our website: <http://www.melexis.com/quality.aspx>

ESD Precautions

Electronic semiconductor products are sensitive to Electro Static Discharge (ESD). Always observe Electro Static Discharge control procedures whenever handling semiconductor products.

MLX90217

Hall-Effect Cam

Disclaimer

Devices sold by Melexis are covered by the warranty and patent indemnification provisions appearing in its Term of Sale. Melexis makes no warranty, express, statutory, implied, or by description regarding the information set forth herein or regarding the freedom of the described devices from patent infringement. Melexis reserves the right to change specifications and prices at any time and without notice. Therefore, prior to designing this product into a system, it is necessary to check with Melexis for current information. This product is intended for use in normal commercial applications. Applications requiring extended temperature range, unusual environmental requirements, or high reliability applications, such as military, medical life-support or life-sustaining equipment are specifically not recommended without additional processing by Melexis for each application.

The information furnished by Melexis is believed to be correct and accurate. However, Melexis shall not be liable to recipient or any third party for any damages, including but not limited to personal injury, property damage, loss of profits, loss of use, interrupt of business or indirect, special incidental or consequential damages, of any kind, in connection with or arising out of the furnishing, performance or use of the technical data herein. No obligation or liability to recipient or any third party shall arise or flow out of Melexis' rendering of technical or other services.

© 2012 Melexis NV. All rights reserved.

For the latest version of this document, go to our website at
www.melexis.com



Or for additional information contact Melexis Direct:

Europe, Africa, Asia:	America:
Phone: +32 1367 0495	Phone: +1 248 306 5400
E-mail: sales_europe@melexis.com	E-mail: sales_usa@melexis.com

ISO/TS 16949 and ISO14001 Certified

Looking for pricing, stock, or lifecycle information?

Click below to explore more details on WIN SOURCE:

-  [View MLX90217LUA-CAA-000-BU on WIN SOURCE](#)
-  [Melexis Technologies NV Information](#)

Optimize Your Supply Chain with WIN SOURCE Solutions

-  Global Sourcing Solution
-  Obsolete Management
-  Cost Control Management
-  Shortage Management
-  Alternative Solution
-  Excess Inventory Management