

# Semiconductor

## ML9473

### 1/3, 1/4, 1/5 Duty 60 Output LCD Driver

#### GENERAL DESCRIPTION

The ML9473 is a LCD driver for dynamic display providing 3-duty-switchable pins (1/3, 1/4, 1/5 duty). It can directly drive LCDs of up to 300, 240 and 180 segments when 1/5, 1/4 and 1/3 duty are selected respectively.

#### FEATURES

- Operating range
  - Supply voltage : 3.0 to 5.5 V
  - Operating temperature range : -40 to + 105°C
- Segment output : 60 pins
  - 1/5 duty : Up to 300 segments can be displayed.
  - 1/4 duty : Up to 240 segments can be displayed.
  - 1/3 duty : Up to 180 segments can be displayed.
- Serial transfer clock frequency : 4 MHz
- Serial interface with CPU : Through three input pins (DATA\_IN, LOAD, and CLOCK)
- Built-in oscillator circuit for COMMON signals
- One-to-one correspondence between input data and output data
  - When input data is at "H" level : Display goes on.
  - When input data is at "L" level : Display goes off.
- The entire display can be turned off. ( $\overline{\text{BLANK}}$  pin)
- Package options  
80-pin plastic TQFP (TQFP80-P-1212-0.50-K) (Product name: ML9473TB)

**BLOCK DIAGRAM**

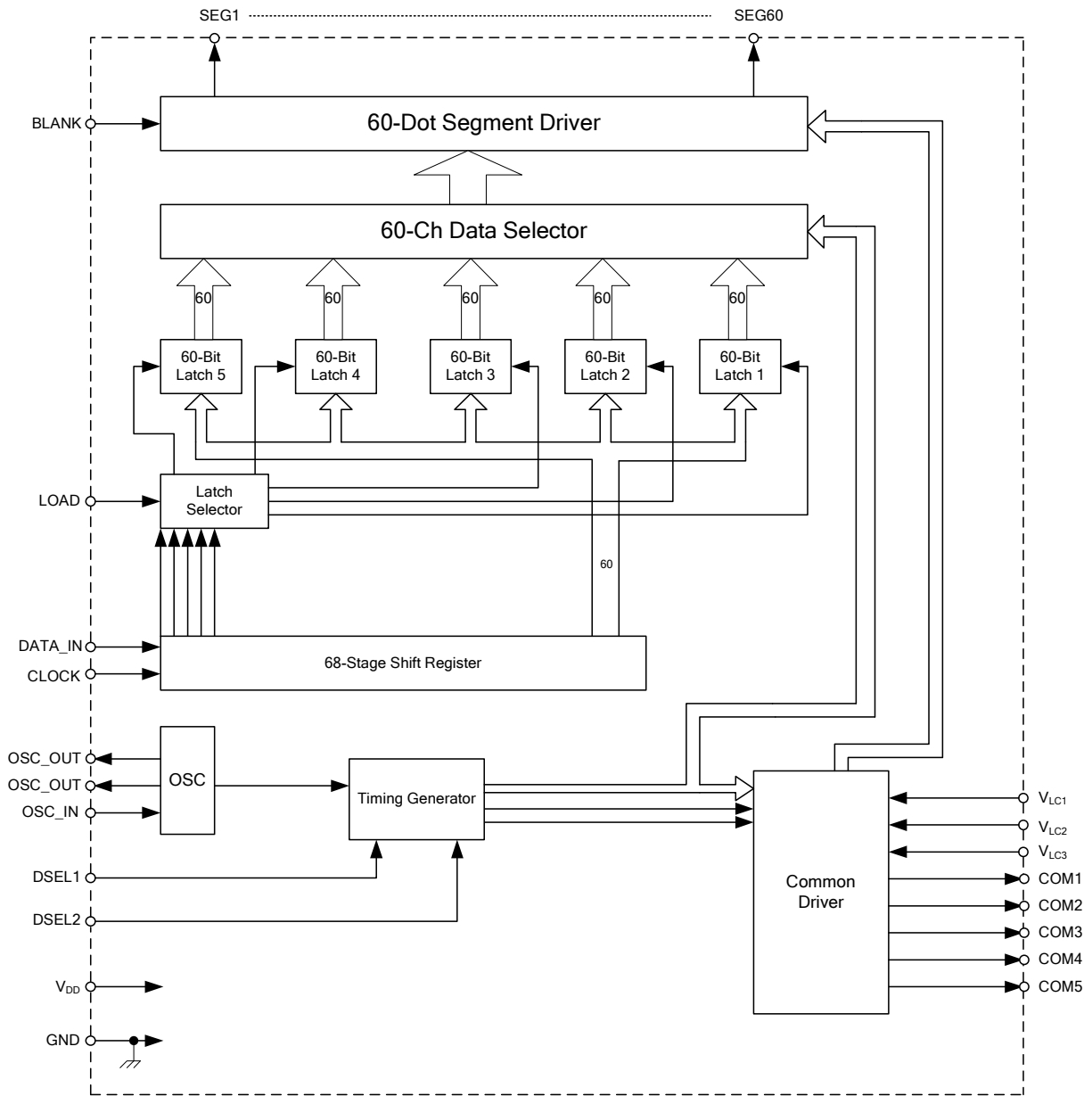

**PIN CONFIGURATION (TOP VIEW)**

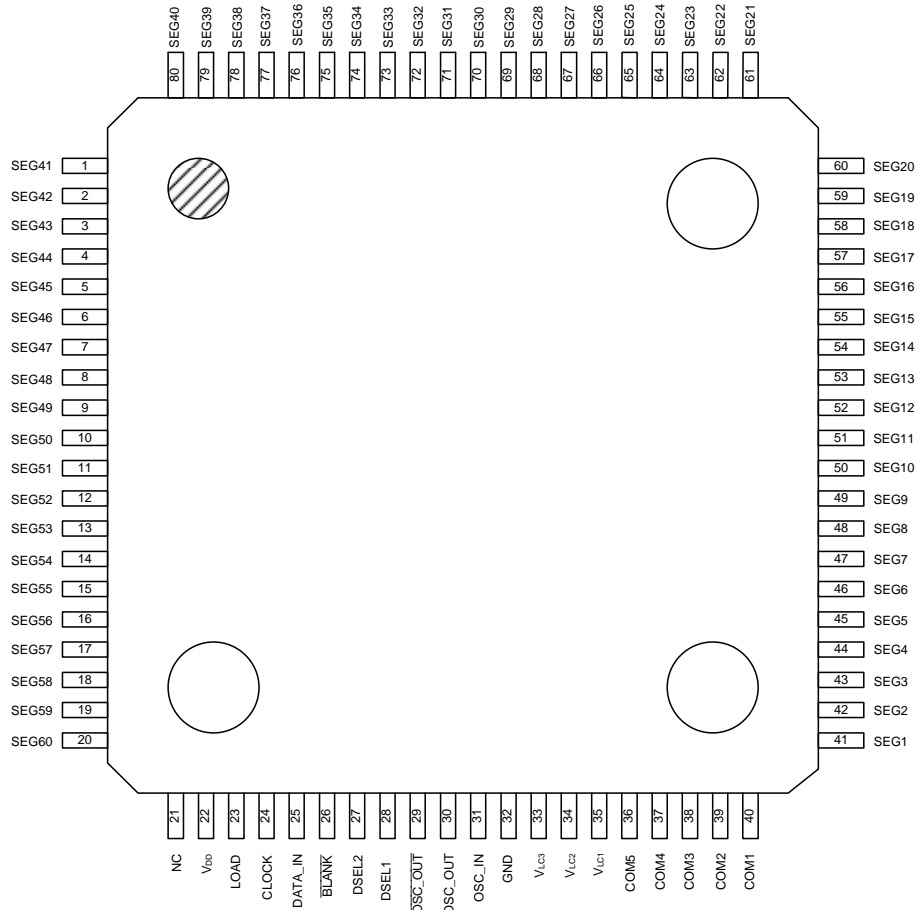

**80-Pin Plastic TQFP**

**PIN DESCRIPTION**

Symbol	Type	Description												
OSC_IN OSC_OUT $\overline{\text{OSC\_OUT}}$	I O O	Pins for oscillation. The oscillator circuit is configured by externally connecting two resistors and a capacitor. Make the wiring length as short as possible, because the resistor connected to the OSC_IN pin has a higher value and the circuit is susceptible to external noise.												
DATA_IN	I	Serial data input pin. The display goes on when input data is at a "H" level, and it goes off when input data is at a "L" level.												
CLOCK	I	Shift clock input pin. Data from the DATA_IN pin is transferred in synchronization with the rising edge of the shift clock.												
LOAD	I	Load signal input pin. Serially input data is transferred to the 60-bit latch at "H" level of this load signal, then held at "L" level.												
$\overline{\text{BLANK}}$	I	Input pin that turns off all segments. The entire display goes off when "L" level is applied to this pin. The display returns to the previous state when "H" level is applied.												
DSEL1 DSEL2	I I	Input pins to select 1/3, 1/4, or 1/5 duty. Following shows how each duty is selected. <table border="1" style="margin-left: auto; margin-right: auto;"> <thead> <tr> <th>DSEL2</th> <th>DSEL1</th> <th>Duty selected</th> </tr> </thead> <tbody> <tr> <td>L</td> <td>L</td> <td>1/3</td> </tr> <tr> <td>L</td> <td>H</td> <td>1/4</td> </tr> <tr> <td>H</td> <td>X</td> <td>1/5</td> </tr> </tbody> </table> <p style="text-align: right; margin-right: 50px;">X: Don't care</p>	DSEL2	DSEL1	Duty selected	L	L	1/3	L	H	1/4	H	X	1/5
DSEL2	DSEL1	Duty selected												
L	L	1/3												
L	H	1/4												
H	X	1/5												
COM1 to COM5	O	Display output pins for LCD. These pins are connected to the COMMON side of the LCD panel.												
SEG1 to SEG60	O	Display output pins for LCD. These pins are connected to the SEGMENT side of the LCD panel. For the correspondence between the output of these pins and input data, see the "Data Structure" Section.												
$V_{\text{LC1}}$ , $V_{\text{LC2}}$ , $V_{\text{LC3}}$	—	Bias pins for LCD driver. Through these pins, bias voltages for the LCD are externally supplied. The bias potential must meet the following condition: $V_{\text{DD}} > V_{\text{LC1}} \geq V_{\text{LC2}} > V_{\text{LC3}} = \text{GND}$												
$V_{\text{DD}}$ , GND	—	Supply voltage pin and ground pin.												

Note: Built-in schmitt circuit is used for all input pins.

**ABSOLUTE MAXIMUM RATINGS**

Parameter	Symbol	Condition	Rating	Unit
Supply Voltage	$V_{DD}$	$T_a = 25^\circ\text{C}$	-0.3 to 6.5	V
Input Voltage	$V_I$	$T_a = 25^\circ\text{C}$	-0.3 to $V_{DD}+0.3$	V
Storage Temperature	$T_{STG}$	—	-55 to 150	$^\circ\text{C}$
Power Dissipation	$P_D$	$T_a < 105^\circ\text{C}$	650	mW
Output Current	$I_O$	—	-2.0 to 2.0	mA

**RECOMMENDED OPERATING CONDITIONS**

Parameter	Symbol	Condition	Range	Unit
Supply Voltage	$V_{DD}$	$V_{LC3} = \text{GND}$	3.0 to 5.5	V
CLOCK Frequency	$f_{CP}$	—	0.75 to 4	MHz
Operating Temperature	$T_a$	—	-40 to 105	$^\circ\text{C}$

**Oscillator Circuit**

Parameter	Symbol	Applicable pin	Condition	Min.	Max.	Unit
Oscillator Resistance	$R_0$	$\overline{\text{OSC\_OUT}}$	—	20	120	$\text{k}\Omega$
Oscillator Capacitance	$C_0$	OSC_OUT	—	0.00047	0.01	$\mu\text{F}$
Current Limiting Resistance	$R_1$	OSC_IN	—	62	360	$\text{k}\Omega$
Common Signal Frequency	$f_{COM}$	COM1 to COM5	—	25	250	Hz

Note: See Section, "Reference Data", for the resistor and capacitor values in the table.

**RC Values in Oscillator Circuit**

Parameter	Symbol	Applicable pin	1/3 duty	1/4 duty	1/5 duty	Unit
Oscillator Resistance	$R_0$	$\overline{\text{OSC\_OUT}}$	68	51	43	$\text{k}\Omega$
Oscillator Capacitance	$C_0$	OSC_OUT	0.001	0.001	0.001	$\mu\text{F}$
Current Limiting Resistance	$R_1$	OSC_IN	220	160	130	$\text{k}\Omega$

Example of an oscillator circuit:

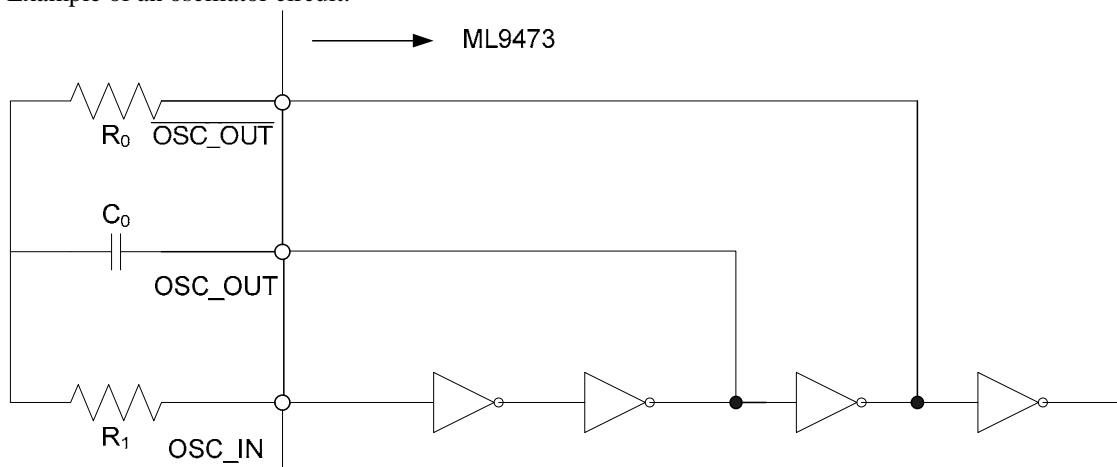

**ELECTRICAL CHARACTERISTICS****DC Characteristics**(V<sub>DD</sub> = 3.0 to 5.5 V, Ta = -40 to +105°C, unless otherwise specified)

Parameter	Symbol	Applicable pin	Condition	Min.	Max.	Unit	
"H" Input Voltage 1	V <sub>IH1</sub>	CLOCK, OSC_IN	—	0.85 V <sub>DD</sub>	V <sub>DD</sub>	V	
"L" Input Voltage 1	V <sub>IL1</sub>	CLOCK, OSC_IN	—	GND	0.15 V <sub>DD</sub>	V	
"H" Input Voltage 2	V <sub>IH2</sub>	*1	—	0.8 V <sub>DD</sub>	V <sub>DD</sub>	V	
"L" Input Voltage 2	V <sub>IL2</sub>	*1	—	GND	0.2 V <sub>DD</sub>	V	
"H" Input Current	I <sub>IH</sub>	All input pins	V <sub>DD</sub> = 5.5 V, V <sub>I</sub> = V <sub>DD</sub>	—	10	μA	
"L" Input Current	I <sub>IL</sub>	All input pins	V <sub>DD</sub> = 5.5 V, V <sub>I</sub> = 0 V	-10	—	μA	
COMMON Output Voltage	V <sub>OC0a</sub>	COM1 - COM5	V <sub>DD</sub> = 3.0 V	I <sub>O</sub> = -100 μA	V <sub>DD</sub> -1	—	V
	V <sub>OC1</sub>			I <sub>O</sub> = ±100 μA *3	V <sub>LC1</sub> -1	V <sub>LC1</sub> +1	V
	V <sub>OC2</sub>			I <sub>O</sub> = ±100 μA *4	V <sub>LC2</sub> -1	V <sub>LC2</sub> +1	V
	V <sub>OC3</sub>			I <sub>O</sub> = +100 μA *5	—	V <sub>LC3</sub> +1	V
Segment Output Voltage	V <sub>OS0</sub>	SEG <sub>1</sub> - SEG <sub>80</sub>	V <sub>DD</sub> = 3.0 V	I <sub>O</sub> = -10 μA	V <sub>DD</sub> -1	—	V
	V <sub>OS1</sub>			I <sub>O</sub> = ±10 μA *3	V <sub>LC1</sub> -1	V <sub>LC1</sub> +1	V
	V <sub>OS2</sub>			I <sub>O</sub> = ±10 μA *4	V <sub>LC2</sub> -1	V <sub>LC2</sub> +1	V
	V <sub>OS3</sub>			I <sub>O</sub> = +10 μA *5	—	V <sub>LC3</sub> +1	V
Supply Current	I <sub>DD</sub>	V <sub>DD</sub>	V <sub>DD</sub> = 5.0 V, no load. *2	—	0.5	mA	

\*1 Applies to all input pins excluding CLOCK and OSC\_IN.

\*2 R<sub>0</sub> = 51 kΩ R<sub>1</sub> = 160 kΩ C<sub>0</sub> = 0.001 μF\*3 V<sub>LC1</sub> = 2.0V\*4 V<sub>LC2</sub> = 1.0V\*5 V<sub>LC3</sub> = 0V

**AC Characteristics**

( $V_{DD} = 3.0$  to  $5.5V$ ,  $T_a = -40$  to  $+105^\circ C$ , unless otherwise specified)

Parameter	Symbol	Condition	Min.	Typ.	Max.	Unit
Clock "H" Time	$t_{WHC}$	—	70	—	—	ns
Clock "L" Time	$t_{WLC}$	—	70	—	—	ns
Data Set-up Time	$t_{DS}$	—	50	—	—	ns
Data Hold Time	$t_{DH}$	—	50	—	—	ns
Load "H" Time	$t_{WHL}$	—	100	—	—	ns
Clock-to-load Time	$t_{CL}$	—	100	—	—	ns
Load-to-Clock Time	$t_{LC}$	—	100	—	—	ns
Clock Rise time, Fall time	$t_{R1}, t_{F1}$	—	—	—	50	ns
OSC_IN Input Frequency	$f_{OSC}$	—	—	—	20	kHz
OSC_IN "H" Time	$t_{WHO}$	—	20	—	—	$\mu s$
OSC_IN "L" Time	$t_{WLO}$	—	20	—	—	$\mu s$
OSC_IN Rise time, Fall time	$t_{R2}, t_{F2}$	—	—	—	100	ns

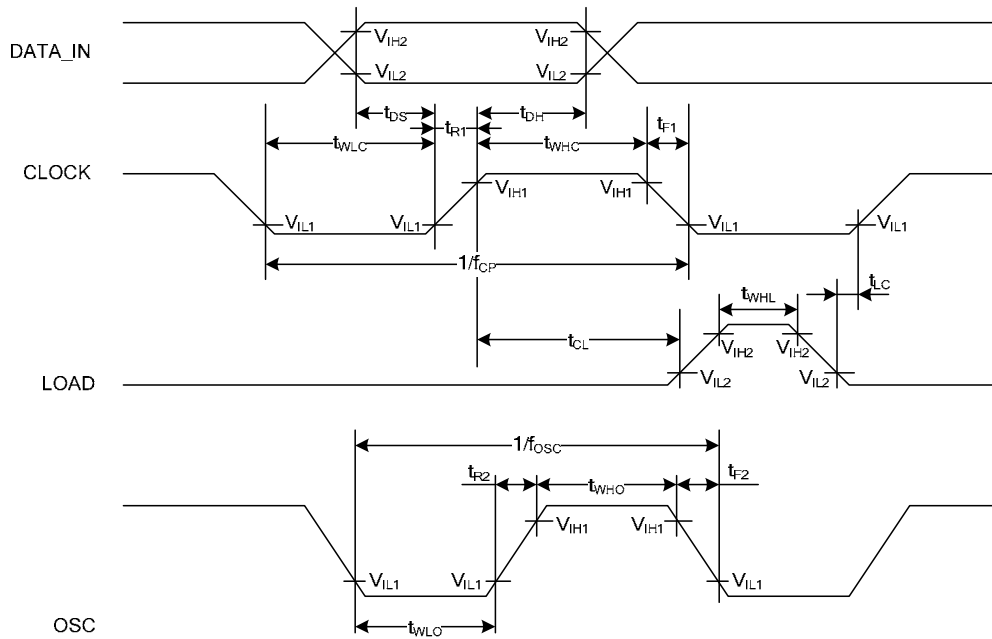

$$\begin{aligned} (V_{IH1} &= 0.85V_{DD} \quad V_{IL1} = 0.15V_{DD}) \\ (V_{IH2} &= 0.8V_{DD} \quad V_{IL2} = 0.2V_{DD}) \end{aligned}$$

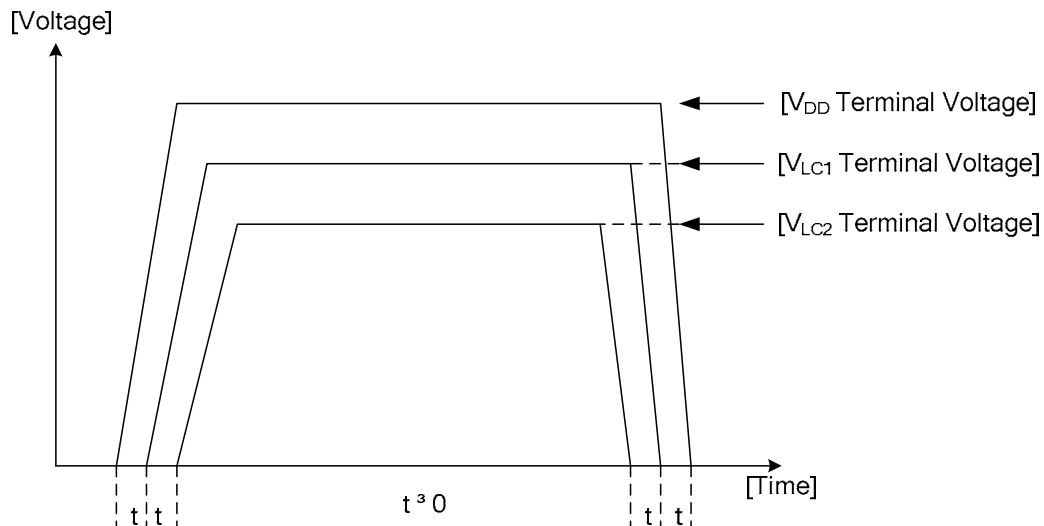
**POWER-ON/OFF TIMING**

\*  $V_{LC1}$ ,  $V_{LC2}$  are applied when  $V_{DD}$  is applied to external bias resistor.

**INITIAL SIGNAL TIMING**

\* Once  $V_{DD}$  is applied,  $\overline{BLANK}$  should be applied to 'L' level to make all SEGMENTs off until first group of display data is latched.

## FUNCTIONAL DESCRIPTION

### Operation

As shown in “Data Structure”, the display data consists of the data field corresponding to the output for turning the segments on or off and the select field that selects field that selects the input block of data. Data input to the DATA\_IN pin is loaded into the 68-bit shift register, transferred to the 60-bit latch while the load signal is at “H” level, and then output via the 60-dot segment driver.

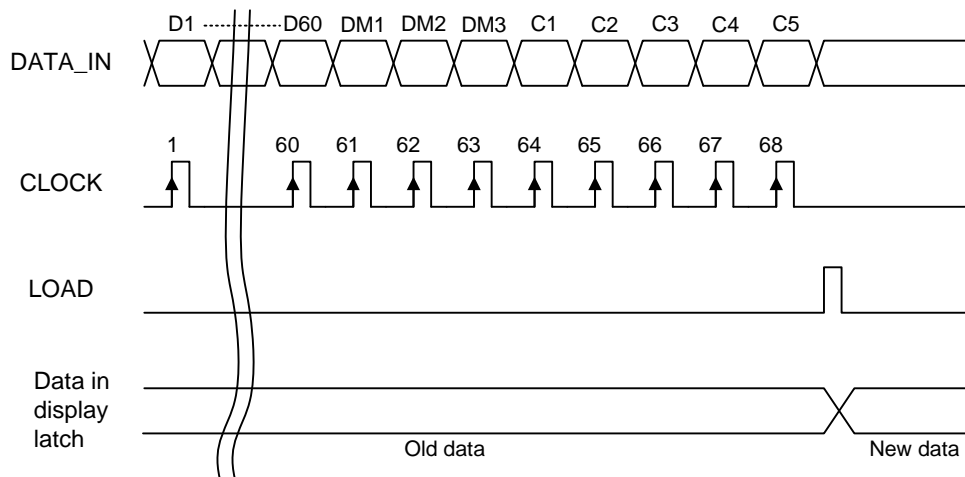

### Data Structure

Input data

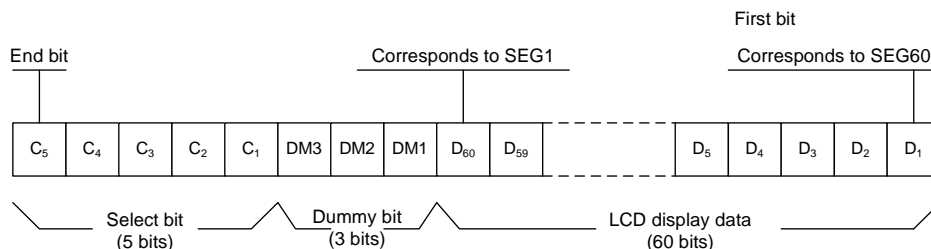

Correspondence between select bits and COM1 to COM5

C5	C4	C3	C2	C1	Description
0	0	0	0	1	Display data corresponding to COM1
0	0	0	1	0	Display data corresponding to COM2
0	0	1	0	0	Display data corresponding to COM3
0	1	0	0	0	Display data corresponding to COM4
1	0	0	0	0	Display data corresponding to COM5

- Notes:
1. Arbitrary data can be set for the dummy bits.
  2. Select bit, C<sub>1</sub> to C<sub>5</sub>, selects 60-bit latches that correspond to COM1 to COM5, respectively. Therefore, if “1” is set for more than one select bit, data is set to all the corresponding 60-bit latches.

Example:

If “1” is set to all the select bits C<sub>1</sub> to C<sub>5</sub>, the display data of D<sub>1</sub> to D<sub>60</sub> is set to all the 60-bit latches that correspond to COM1 to COM5.

**COM1 – COM5 Timing Chart:**

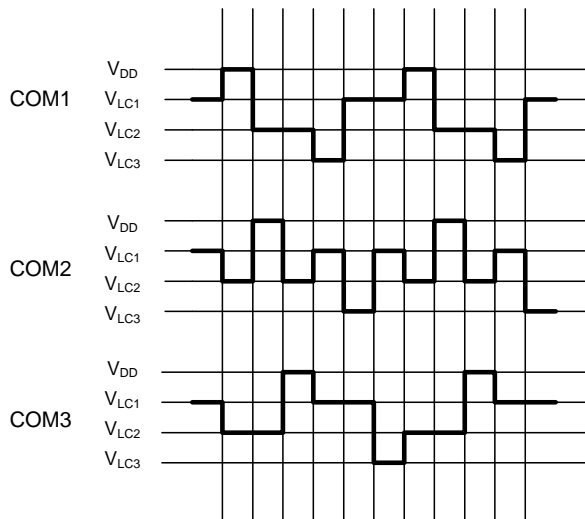

1/3 DUTY COM  
TIMING

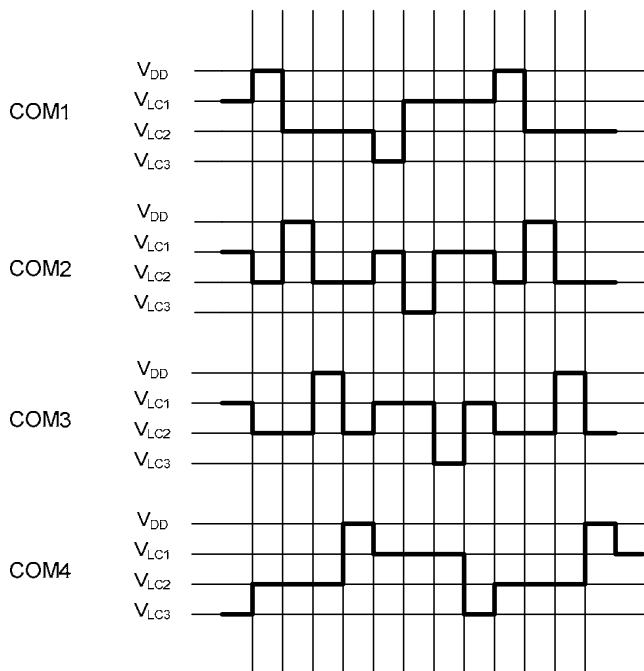

1/4 DUTY COM  
TIMING

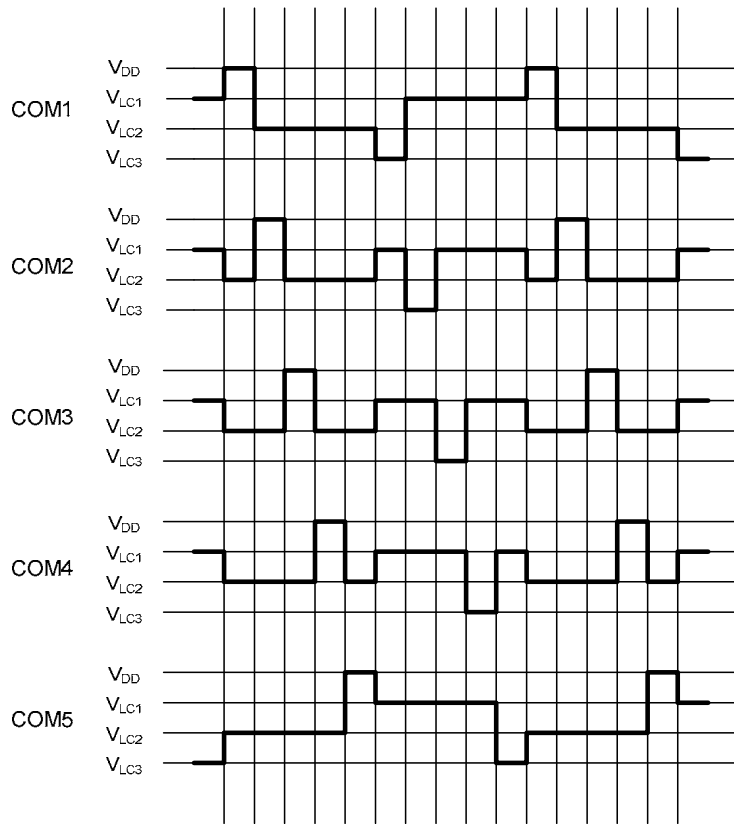

1/5 DUTY COM  
TIMING

**SEGn True Value Table:**

LATCH1	LATCH2	LATCH3	LATCH4	LATCH5	COM1	COM2	COM3	COM4	COM5	SEGn
0	0	0	0	1	"H"	"M2"	"M2"	"M2"	"M2"	"M1"
					"L"	"M1"	"M1"	"M1"	"M1"	"M2"
					"M2"	"H"	"M2"	"M2"	"M2"	"M1"
					"M1"	"L"	"M1"	"M1"	"M1"	"M2"
					"M2"	"M2"	"H"	"M2"	"M2"	"M1"
					"M1"	"M1"	"L"	"M1"	"M1"	"M2"
					"M2"	"M2"	"M2"	"H"	"M2"	"M1"
					"M1"	"M1"	"M1"	"L"	"M1"	"M2"
					"M2"	"M2"	"M2"	"M2"	"H"	"L"
					"M1"	"M1"	"M1"	"M1"	"L"	"H"

\*Note: "H" = V<sub>DD</sub>; "M1" = V<sub>LC1</sub>; "M2" = V<sub>LC2</sub>; "L" = V<sub>LC3</sub>=GND

**Timing Chart FOR 1/3 DUTY DRIVE MODE:**

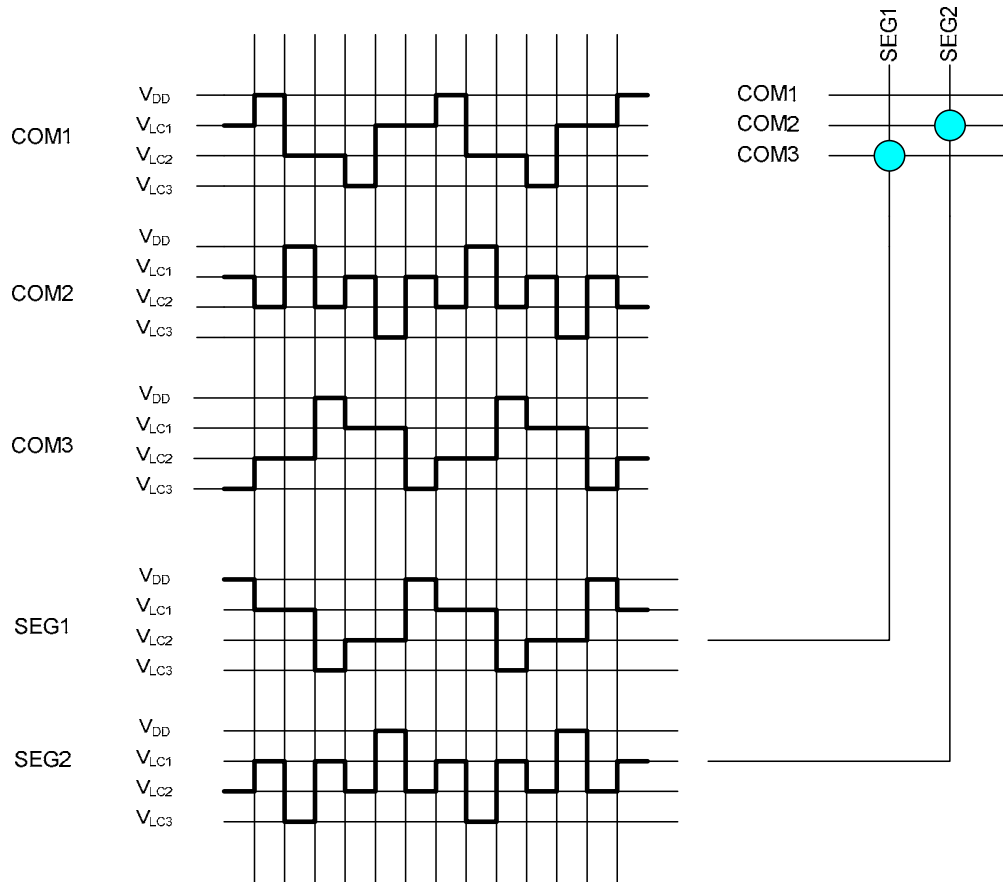

**Timing Chart FOR 1/4 DUTY DRIVE MODE:**

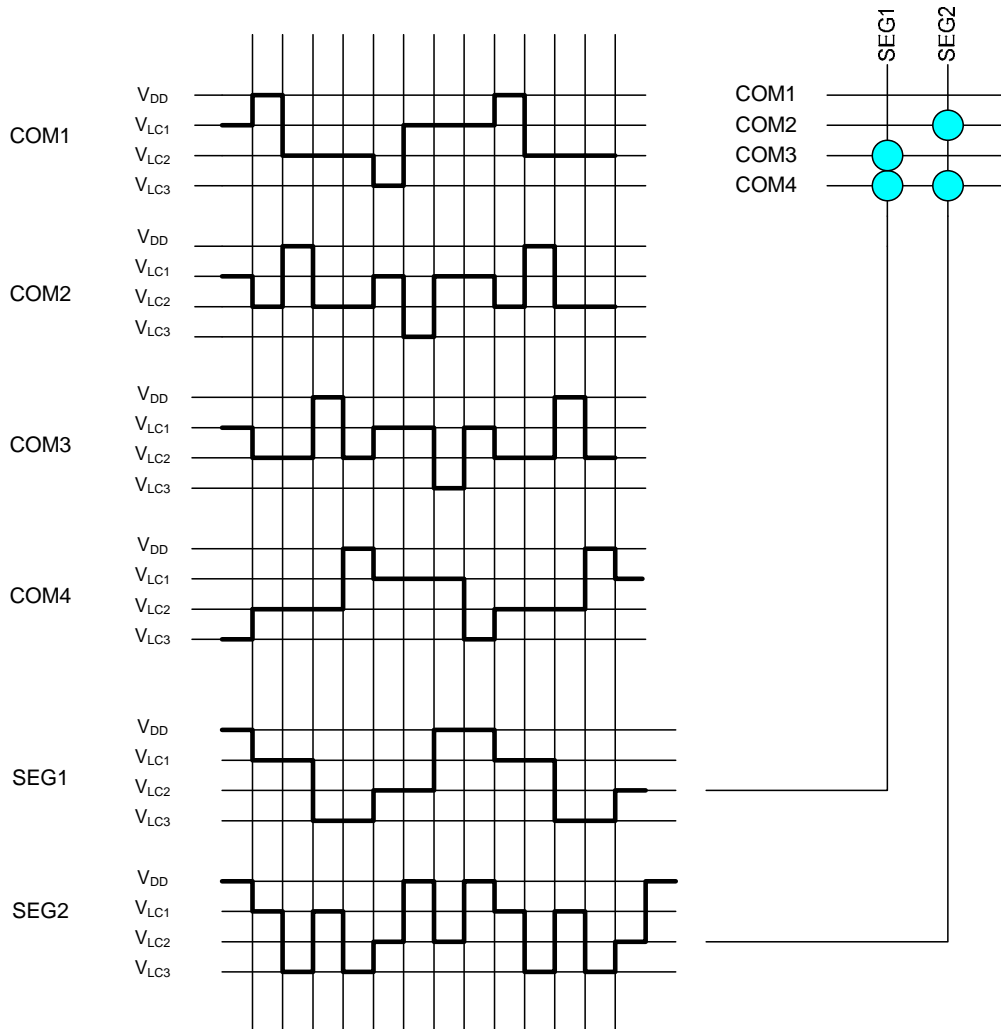

**Timing Chart FOR 1/5 DUTY DRIVE MODE:**

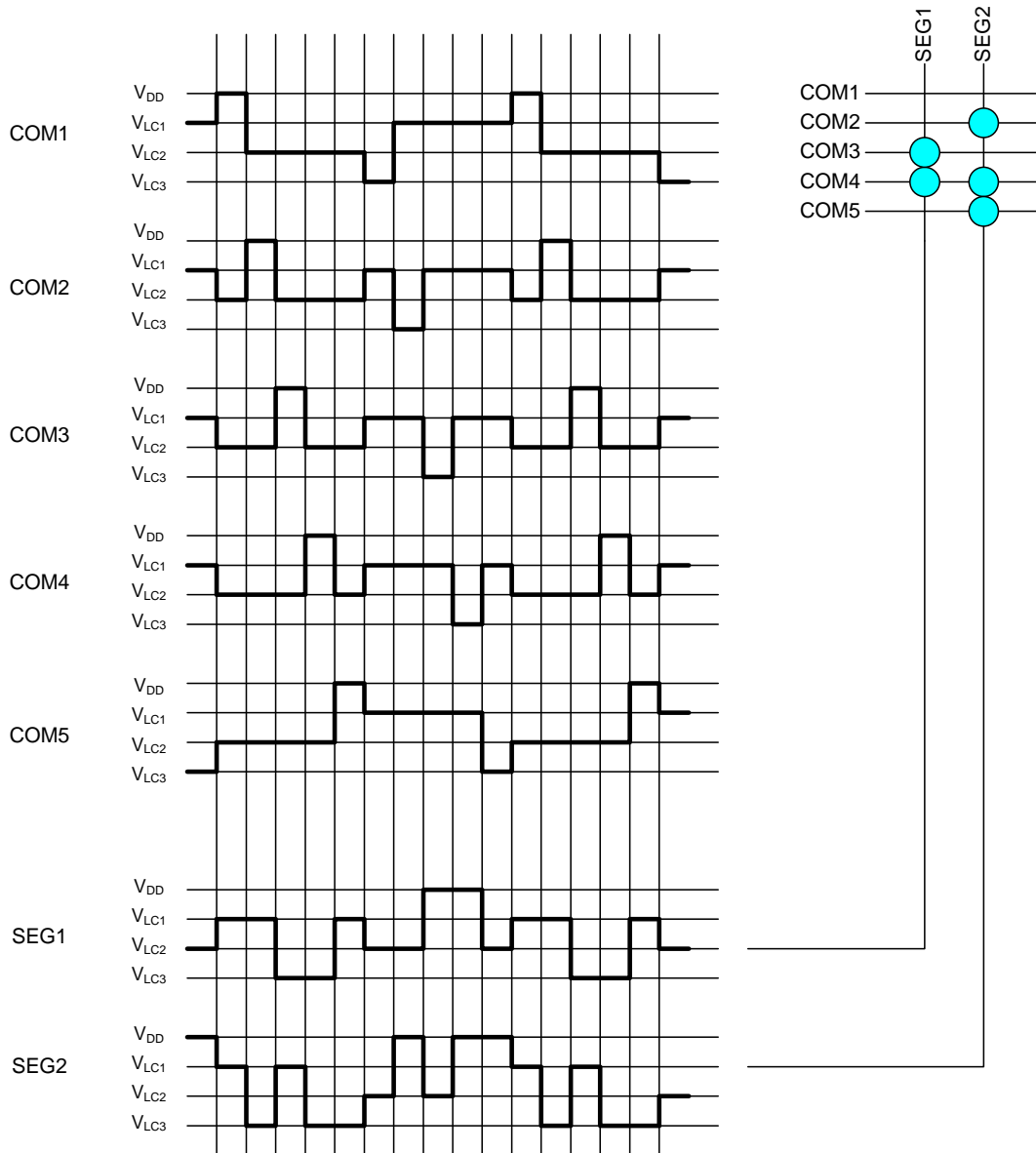

**APPLICATION CIRCUITS**  
(For 1/4 duty)

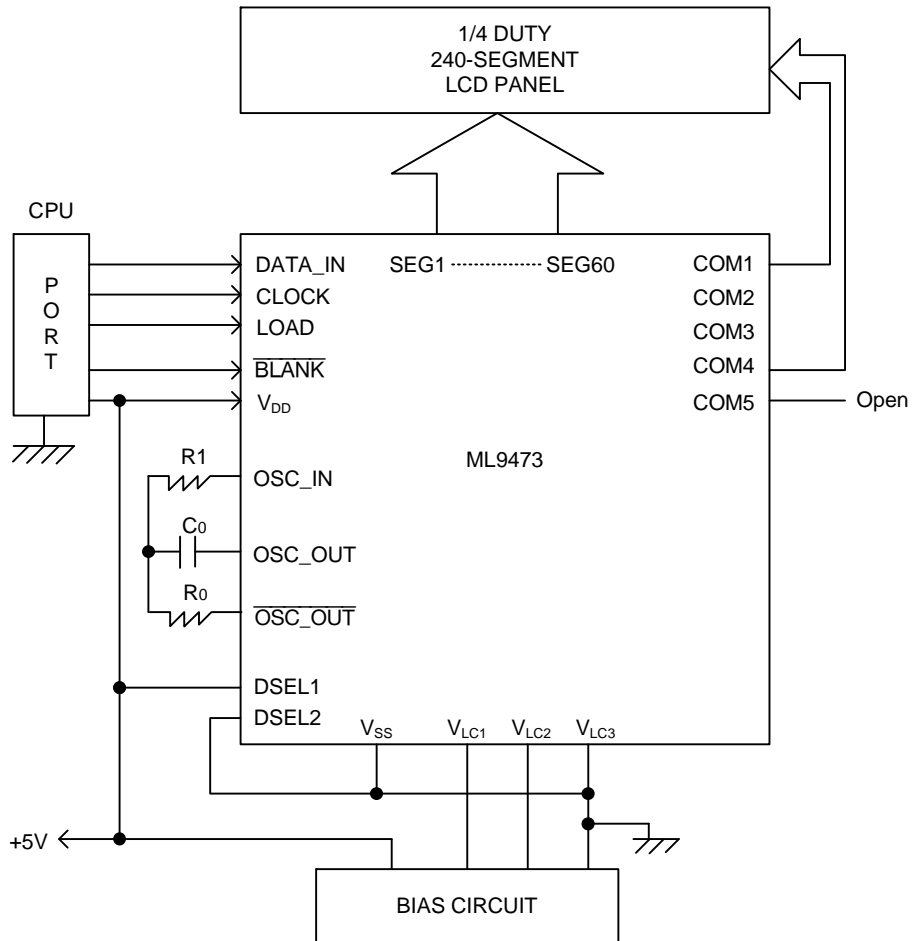

## REFERENCE DATA

The data shown in this section is for reference (a metal film resistor and a film capacitor are used). Resistor and capacitor values must be determined based on experiments.

Use the following expression to convert oscillation frequency to COMMON frame frequency (or vice versa):

$$f_{\text{COM}} = f_{\text{OSC}} \times \text{Duty}/16$$

$f_{\text{COM}}$  : COMMON frame frequency  
 $f_{\text{OSC}}$  : Oscillation frequency  
 Duty : e.g., 1/4 for 1/4 duty

For example, if  $f_{\text{COM}}=100\text{Hz}$  at 1/5 duty, the oscillation frequency is  $f_{\text{OSC}}=8000\text{Hz}$ .

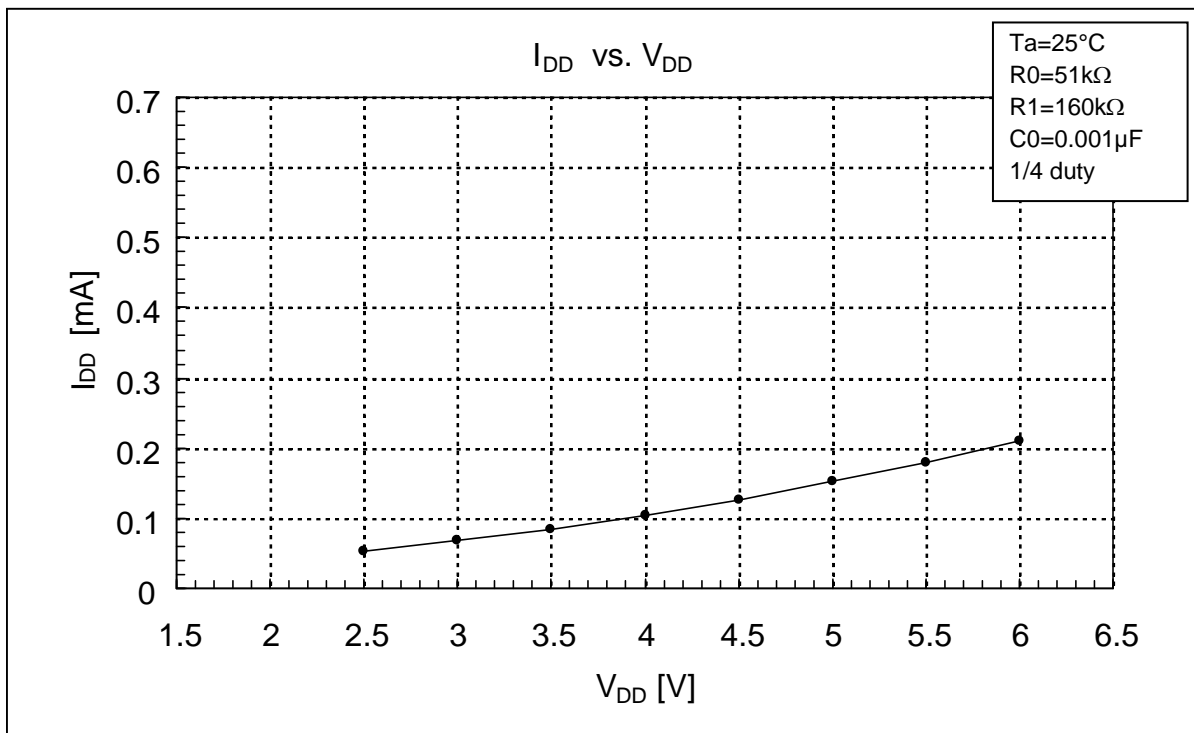

fOSC---R0,C0

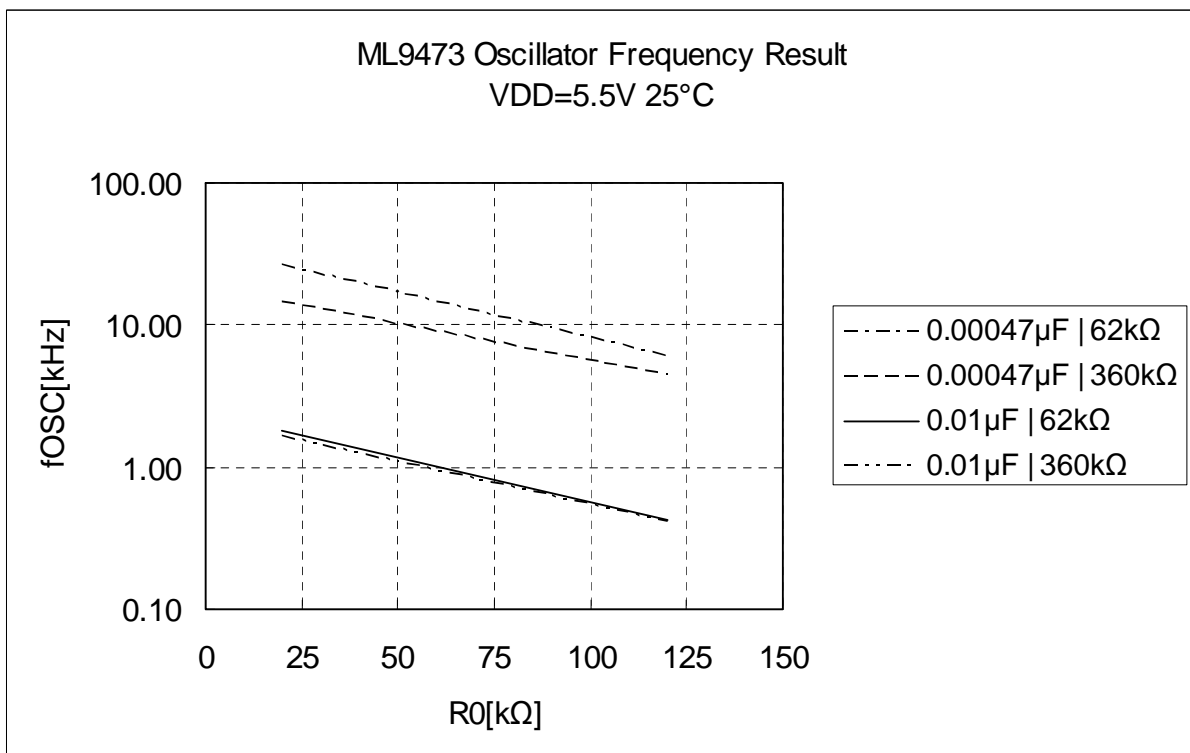
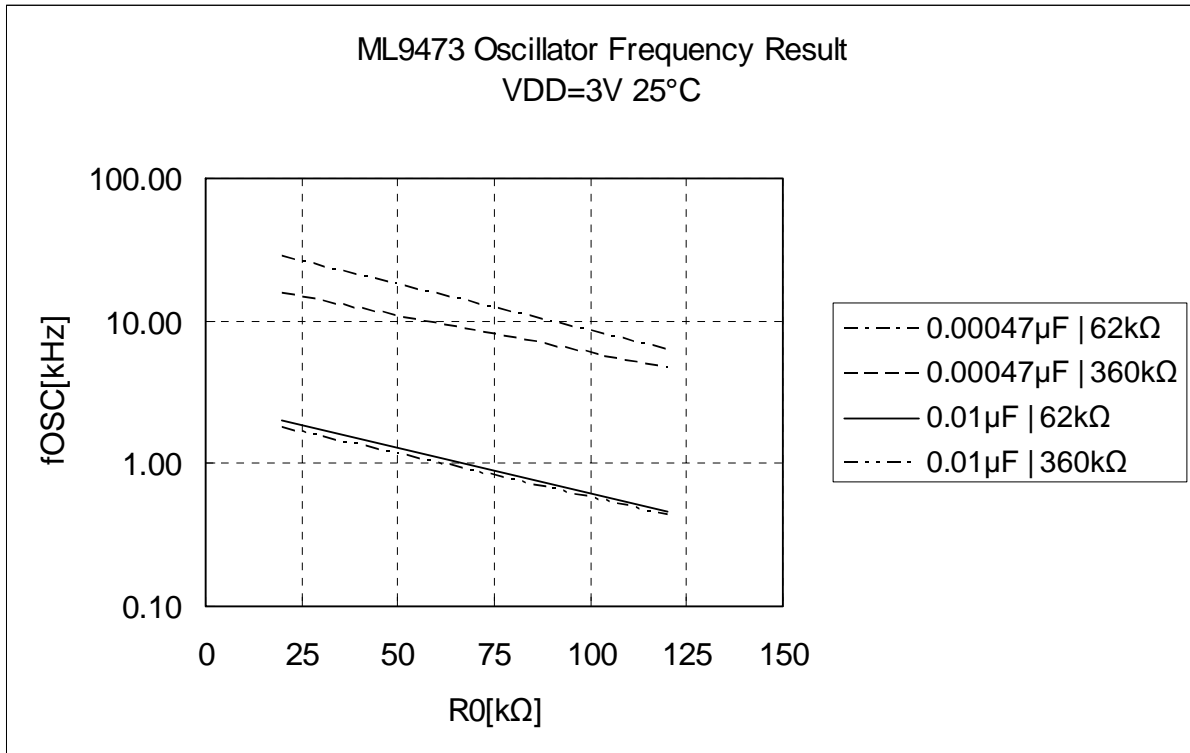

**PACKAGE DIMENSIONS**

(Unit: mm)

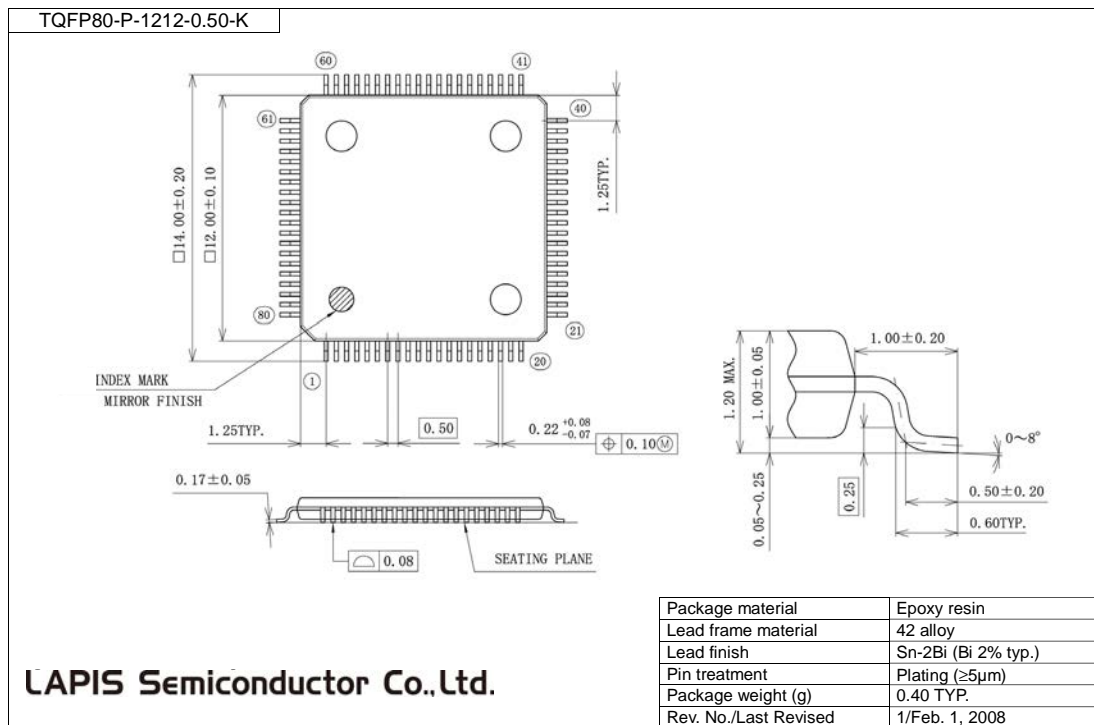

Notes for Mounting the Surface Mount Type Package

The surface mount type packages are very susceptible to heat in reflow mounting and humidity absorbed in storage. Therefore, before you perform reflow mounting, contact ROHM's responsible sales person for the product name, package name, pin number, package code and desired mounting conditions (reflow method, temperature and times).

**REVISION HISTORY**

Document No.	Date	Page		Description
		Previous Edition	Current Edition	
PEDL9473-01	Dec. 15, 2006	–	–	Preliminary edition 1
PEDL9473-02	Jan. 15, 2007	–	–	Preliminary edition 2
PEDL9473-03	Jan. 9, 2008	–	–	Preliminary edition 3
FEDL9473-01	Aug. 21, 2008	–	–	Final edition 1

**NOTICE**

No copying or reproduction of this document, in part or in whole, is permitted without the consent of LAPIS Semiconductor Co., Ltd.

The content specified herein is subject to change for improvement without notice.

The content specified herein is for the purpose of introducing LAPIS Semiconductor's products (hereinafter "Products"). If you wish to use any such Product, please be sure to refer to the specifications, which can be obtained from LAPIS Semiconductor upon request.

Examples of application circuits, circuit constants and any other information contained herein illustrate the standard usage and operations of the Products. The peripheral conditions must be taken into account when designing circuits for mass production.

Great care was taken in ensuring the accuracy of the information specified in this document. However, should you incur any damage arising from any inaccuracy or misprint of such information, LAPIS Semiconductor shall bear no responsibility for such damage.

The technical information specified herein is intended only to show the typical functions of and examples of application circuits for the Products. LAPIS Semiconductor does not grant you, explicitly or implicitly, any license to use or exercise intellectual property or other rights held by LAPIS Semiconductor and other parties. LAPIS Semiconductor shall bear no responsibility whatsoever for any dispute arising from the use of such technical information.

The Products specified in this document are intended to be used with general-use electronic equipment or devices (such as audio visual equipment, office-automation equipment, communication devices, electronic appliances and amusement devices).

The Products specified in this document are not designed to be radiation tolerant.

While LAPIS Semiconductor always makes efforts to enhance the quality and reliability of its Products, a Product may fail or malfunction for a variety of reasons.

Please be sure to implement in your equipment using the Products safety measures to guard against the possibility of physical injury, fire or any other damage caused in the event of the failure of any Product, such as derating, redundancy, fire control and fail-safe designs. LAPIS Semiconductor shall bear no responsibility whatsoever for your use of any Product outside of the prescribed scope or not in accordance with the instruction manual.



The Products are not designed or manufactured to be used with any equipment, device or system which requires an extremely high level of reliability the failure or malfunction of which may result in a direct threat to human life or create a risk of human injury (such as a medical instrument, transportation equipment, aerospace machinery, nuclear-reactor controller, fuel-controller or other safety device). LAPIS Semiconductor shall bear no responsibility in any way for use of any of the Products for the above special purposes. If a Product is intended to be used for any such special purpose, please contact a ROHM sales representative before purchasing.

If you intend to export or ship overseas any Product or technology specified herein that may be controlled under the Foreign Exchange and the Foreign Trade Law, you will be required to obtain a license or permit under the Law.

Copyright 2008 - 2011 LAPIS Semiconductor Co., Ltd.

## Looking for pricing, stock, or lifecycle information?

Click below to explore more details on WIN SOURCE:

-  [View ML9473](#) on WIN SOURCE
-  [Rohm Semiconductor](#) Information

## Optimize Your Supply Chain with WIN SOURCE Solutions

-  Global Sourcing Solution
-  Obsolete Management
-  Cost Control Management
-  Shortage Management
-  Alternative Solution
-  Excess Inventory Management