



**THE DATASHEET OF
ML4821CS**



ML4821

Power Factor Controller

Features

- Average current sensing for lowest possible harmonic distortion
- Average line compensation with brown-out control
- Precision buffered 5V reference
- 1A peak current totem-pole output drive
- Overvoltage comparator eliminates output “runaway” due to load removal
- Wide common mode range in current sense comparators for better noise immunity
- Large oscillator amplitude for better noise immunity
- Output driver internally limited to 17V
- “Sleep mode” shutdown input

General Description

The ML4821 provides complete control for a “boost” type power factor correction system using the average current sensing method. Special care has been taken in the design of the ML4821 to increase system noise immunity. The circuit includes a precision reference, gain modulator, average current error amplifier, output error amplifier, over-voltage protection comparator, shutdown logic, as well as a high current output. In addition, start-up is simplified by an under-voltage lockout circuit.

In a typical application, the ML4821 controls the AC input current by adjusting the pulse width of the output MOSFET. This modulates the line current so that its shape conforms to the shape of the input voltage. The reference for the current regulator is a product of the sinusoidal line voltage times the output of the error amplifier which is regulating the output DC voltage. Average line voltage compensation is provided in the gain modulator to ensure constant loop gain over a wide input voltage range. This compensation includes a special “brown-out” control which reduces output power below 90V RMS input.

Block Diagram

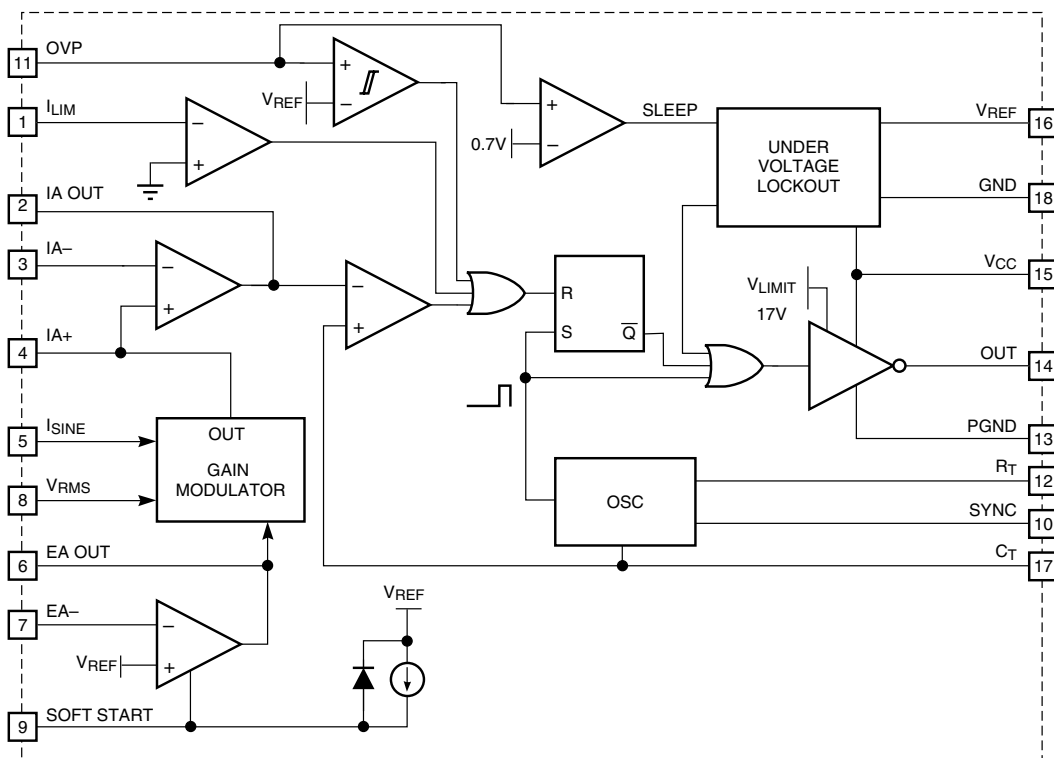

Pin Connection

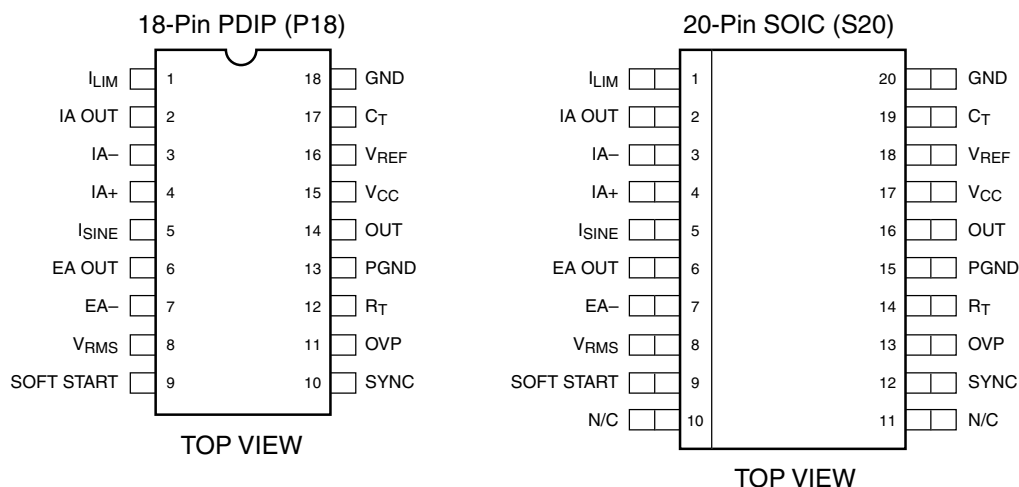

Pin Description

| Pin Number | | Name | Function |
|------------|-------------|------------|--|
| 18-Pin DIP | 20-Pin SOIC | | |
| 1 | 1 | ILIM | Peak cycle-by-cycle current limit input |
| 2 | 2 | IA OUT | Output and compensation node of the average current error amplifier |
| 3 | 3 | IA- | Inverting input of the average current error amplifier |
| 4 | 4 | IA+ | Non-Inverting input of the average current error amplifier and output of the gain modulator |
| 5 | 5 | ISINE | Gain modulator input |
| 6 | 6 | EA OUT | Output of output voltage error amplifier |
| 7 | 7 | INV | Inverting input to error amplifier |
| 8 | 8 | VRMS | Input for average line voltage compensation |
| 9 | 9 | SOFT START | Normally connected to soft start capacitor |
| 10 | 12 | SYNC | Oscillator synchronization input |
| 11 | 13 | OVP | Inhibits output pulses when the voltage at this pin exceeds 5V. Also, when the voltage at this pin is less than 0.7V, the IC goes into low current shut-down mode. |
| 12 | 14 | RT | Timing resistor for the oscillator |
| 13 | 15 | PWR GND | Return for the high current totem pole output |
| 14 | 16 | OUT | High current totem pole output |
| 15 | 17 | VCC | Positive supply for the IC |
| 16 | 18 | VREF | Buffered output for the 5V voltage reference |
| 17 | 19 | CT | Timing capacitor for the oscillator. |
| 18 | 20 | GND | Analog signal ground |

Absolute maximum ratings

Absolute maximum ratings are those values beyond which the device could be permanently damaged. Absolute maximum ratings are stress ratings only and functional device operation is not implied.

| Parameter | Min | Max | Units |
|---|-----------|-----|-------|
| Supply Current (I _{CC}) | | 35 | mA |
| OUT Current, Source or Sink | | 1.0 | A |
| Output Energy (capacitive load per cycle) | | 5 | μJ |
| ISINE Input Current | | 1.2 | mA |
| EA OUT Source Current | | 50 | mA |
| Oscillator Charge Current | | 2 | mA |
| Input Voltage | GND -0.3V | 5.5 | V |
| Junction Temperature | | 150 | °C |
| Storage Temperature Range | -65 | 150 | °C |
| Lead Temperature (Soldering 10 sec.) | | 260 | °C |
| Thermal Resistance (θ _{JA}) | | | |
| Plastic DIP | | 75 | °C/W |
| Plastic SOIC | | 95 | °C/W |

Operating Conditions

| Temperature Range | Min | Max | Units |
|-------------------|-----|-----|-------|
| ML4821CX | 0 | 70 | °C |

Electrical Characteristics

Unless otherwise specified, R_T = 6.2kΩ, C_T = 720pF, T_A = Operating Temperature Range, V_{CC} = 15V (Notes 1 & 2).

| Parameter | Conditions | Min. | Typ. | Max. | Units |
|------------------------|---|------|------|------|-------|
| Oscillator | | | | | |
| Initial accuracy | T _A = 25°C | 90 | 100 | 110 | kHz |
| Voltage stability | 12V < V _{CC} < 18V | | 1 | | % |
| Temperature stability | | | 2 | | % |
| Total Variation | Line, Temperature | 85 | | 115 | kHz |
| Ramp Valley to Peak | | 4.7 | 5.2 | 5.6 | V |
| R _T Voltage | | 4.8 | 5.0 | 5.2 | V |
| Discharge Current | C _T = 2V, R _T = Open | 7.8 | 8.4 | 9.3 | mA |
| SYNC Input Threshold | | 1.5 | 2.0 | 3.0 | V |
| Reference | | | | | |
| Output Voltage | T _A = 25°C, I _O = 1mA | 4.95 | 5.00 | 5.05 | V |
| Line regulation | 12V < V _{CC} < 24V | | 2 | 10 | mV |
| Load regulation | 1mA < I _O < 20mA | | 2 | 15 | mV |
| Temperature stability | | | .4 | | % |
| Total Variation | line, load, temp | 4.9 | | 5.1 | V |
| Output Noise Voltage | 10Hz to 10kHz | | 50 | | μV |
| Long Term Stability | T _A = 125°C, 1000 hrs | | 5 | 25 | mV |
| Short Circuit Current | V _{REF} = 0V | -30 | -85 | -180 | mA |

Electrical Characteristics (continued)Unless otherwise specified, $R_T = 6.2k\Omega$, $C_T = 720pF$, $T_A =$ Operating Temperature Range, $V_{CC} = 15V$ (Notes 1 & 2).

| Parameter | Conditions | Min. | Typ. | Max. | Units |
|--------------------------------|--|------|-------|------|---------|
| Voltage Error Amplifier | | | | | |
| Input Offset Voltage | | 0 | | -15 | mV |
| Input Bias Current | | | -50 | -800 | nA |
| Open Loop Gain | $2 < EA\ OUT < 6V$ | 60 | 75 | | dB |
| PSRR | $12V < V_{CC} < 24V$ | 70 | 100 | | dB |
| Output Sink Current | $EA\ OUT = 4V, INV = 5.5V$ | 300 | 500 | | μA |
| Output Source Current | $EA\ OUT = 4.0V, INV = 4.8V$ | -10 | -30 | | mA |
| Output High Voltage | $IPIN6 = -5mA, VPIN7 = 4.8V$ | 7.0 | 7.5 | | V |
| Output Low Voltage | $IPIN6 = 0, EA- = 5.5V$ | | 0 | 0.5 | V |
| Unity Gain Bandwidth | | | 1.0 | | MHz |
| Soft Start Charge Current | $VPIN9 = 4V$ | -22 | -38 | -50 | μA |
| Current Error Amplifier | | | | | |
| Input Offset Voltage | | -5 | 0 | 5 | mV |
| Input Bias Current | | | -0.15 | -1 | μA |
| Input Offset Current | | | | 400 | nA |
| Open Loop Gain | $2 < EA\ OUT < 7V$ | 80 | 100 | | dB |
| PSRR | $12V < V_{CC} < 24V$ | 65 | 85 | | dB |
| Output Voltage Low | $I_{OL} = 300\mu A$ | | 0 | 0.5 | V |
| Output Voltage High | $I_{OH} = -10mA$ | 7.0 | 7.5 | | V |
| Input Common Mode Range | | -0.3 | | 2.5 | V |
| Gain Modulator | | | | | |
| Gain | $V_{INV} = 4.8V, V_{RMS} = 0V$ | 0.75 | 1.2 | 1.3 | |
| | $V_{INV} = 4.8V, V_{RMS} = 1.75V$ | 3.1 | 3.88 | 4.5 | |
| | $V_{INV} = 4.8V, V_{RMS} = 2.6V$ | 1.25 | 1.75 | 2.15 | |
| | $V_{INV} = 4.8V, V_{RMS} = 5.2V$ | 0.22 | 0.38 | 0.50 | |
| Output Current | $V_{INV} = 5.2V, V_{RMS} = 5.2V$ | | -2 | -4 | μA |
| Output Current Limit | $V_{INV} = 4.8V, I_{SINE} = 500\mu A, V_{RMS} = 1.75V$ | 360 | 395 | 420 | μA |
| ILIM Comparator | | | | | |
| Input Offset Voltage | | | | +15 | mV |
| Input Bias Current | | | -100 | -200 | μA |
| OVP Comparator | | | | | |
| Input Offset Voltage | Output Off | -25 | | 5 | mV |
| Hysteresis | Output On | 85 | 105 | 130 | mV |
| Input Bias Current | | | -0.3 | -3 | μA |
| Propagation Delay | | | 150 | | ns |
| Shutdown Threshold | | 0.4 | 0.7 | 1.0 | V |
| PWM Comparator | | | | | |
| Input Common Mode Range | | 0 | | 8 | V |
| Propagation Delay | | | 150 | | ns |

Electrical Characteristics (continued)

Unless otherwise specified, $R_T = 6.2k\Omega$, $C_T = 720pF$, $T_A =$ Operating Temperature Range, $V_{CC} = 15V$ (Notes 1 & 2).

| Parameter | Conditions | Min. | Typ. | Max. | Units |
|------------------------------|---|------|------|------|-------|
| Output | | | | | |
| Output Voltage Low | $I_{OUT} = 20mA$ | | 0.1 | 0.4 | V |
| | $I_{OUT} = 200mA$ | | 1.6 | 2.4 | V |
| Output Voltage High | $I_{OUT} = -20mA$ | 13 | 13.5 | | V |
| | $I_{OUT} = -200mA$ | 12 | 13.4 | | V |
| Output Voltage Low in UVLO | $I_{OUT} = -5mA$, $V_{CC} = 8V$ | | 0.1 | 0.8 | V |
| Output Rise/Fall Time | $C_L = 1000pF$ | | 50 | | ns |
| Undervoltage Lockout | | | | | |
| Start-up Threshold | | 14.5 | | 16.5 | V |
| Shut-Down Threshold | | 8.5 | | 11.0 | V |
| VREF Good Threshold | | | 4.4 | | V |
| Supply | | | | | |
| Supply Current | Start-up, $V_{CC} = 14V$, $T_A = 25^\circ C$ | | 0.6 | 1.2 | mA |
| | Operating, $T_A = 25^\circ C$ | | 26 | 32 | mA |
| Internal Shunt Zener Voltage | $I_{CC} = 35mA$ | 25 | 27 | 35 | V |

Notes:

- Limits are guaranteed by 100% testing, sampling or correlation with worst case test conditions.
- V_{CC} is raised above the start-up threshold first to activate the IC, then returned to 15V
- Gain Modulator gain is defined as:

$$\frac{I_{OUTIA+}}{I_{INEAOUT}}$$

Functional Description

Oscillator

The ML4821 oscillator charges the external capacitor connected to C_T with a current equal to $2.5/R_T$. When the capacitor voltage reaches the upper threshold, the comparator changes state and the capacitor discharges to the lower threshold through Q1.

The oscillator period can be described by the following relationship:

$$T_{OSC} = T_{RAMP} + T_{DISCHARGE}$$

where:

$$T_{RAMP} = C(Ramp\ Valley\ to\ Peak) \div (I_{RT}/2)$$

and:

$$T_{DISCHARGE} = C(Ramp\ Valley\ to\ Pk) \div (8.4mA - I_{RT}/2)$$

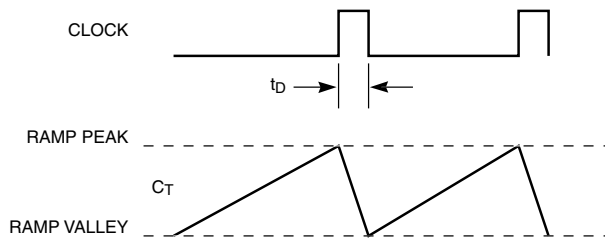

The ML4821 oscillator includes a SYNC input for synchronizing to an external frequency source. A positive pulse on this pin of 2V (typ) resets the oscillators comparator and initiates a discharge cycle for C_T . The R_T and C_T component values which set the ML4821 oscillator frequency should be selected to produce a lower frequency than the external frequency source.

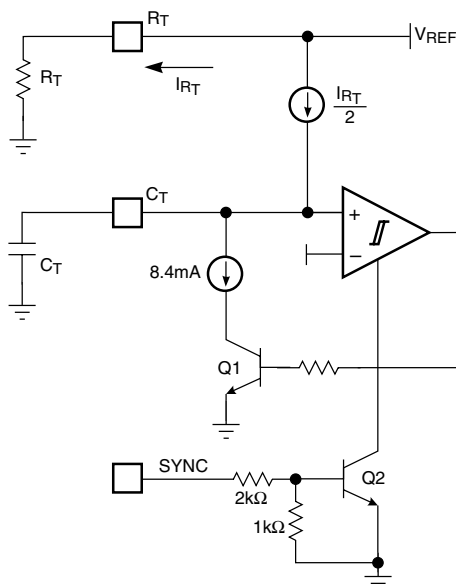

Figure 1. Oscillator Block Diagram

VOLTAGE and Current ERROR Amplifiers

The ML4821 voltage error amplifier is a high open loop gain, wide bandwidth amplifier with a class A output. The soft start circuit controls the input to this amplifier for closed loop soft start operation.

The current error amplifier (IA) is similar to the voltage error amplifier but is designed for very low offsets to allow the selection of a low value resistor for R_{SENSE} .

Output Driver Stage

The ML4821 Output Driver is a 1A peak output high speed totem pole circuit designed to quickly drive capacitive loads, such as power MOSFET gates. The driver circuit's output voltage is internally limited to 17V.

Gain Modulator

The ML4821 gain modulator responds linearly to current injected into the I_{SINE} pin, and in an inverse-square fashion to voltage on the V_{RMS} pin. At very low voltages on the V_{RMS} pin, the gain modulator enforces a power limit, or "brown-out protection", upon the overall PFC circuit (Figures 6 and 7). The rectified line input sine wave is converted to a current for the I_{SINE} input via a dropping resistor. In this way, most ground noise produces an insignificant effect on the reference to the PWM comparator. This gives the ML4821 a high degree of immunity to the disturbances common in high-power switching circuits.

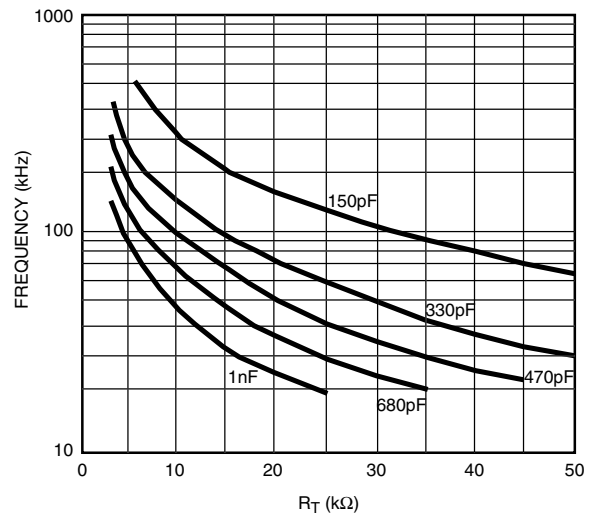

Figure 2. Oscillator Timing Resistance vs. Frequency

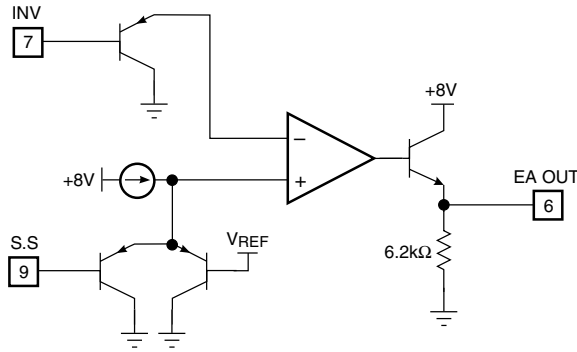

Figure 3. Error and Current Amplifier Configuration

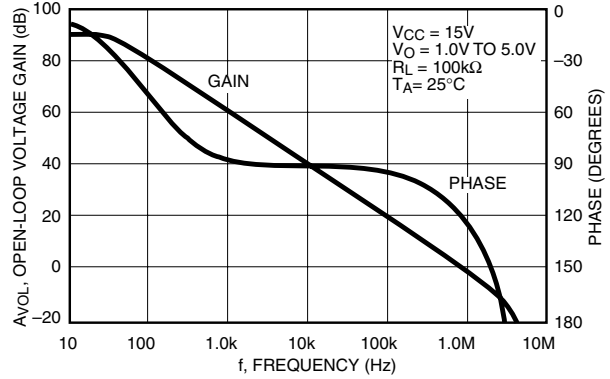

Figure 4. Error Amplifier Open-loop Gain and Phase vs. Frequency.

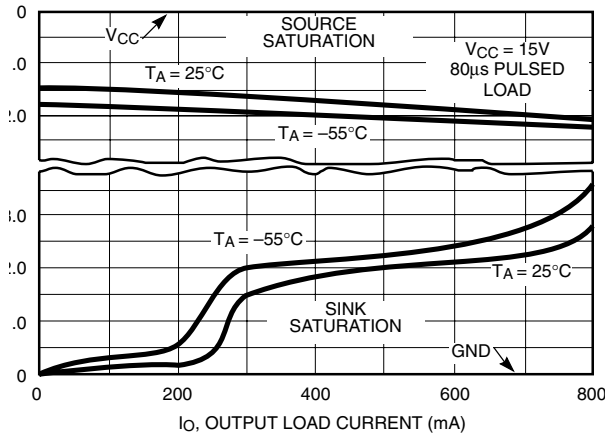

Figure 5. Output Saturation Voltage vs. Output Current.

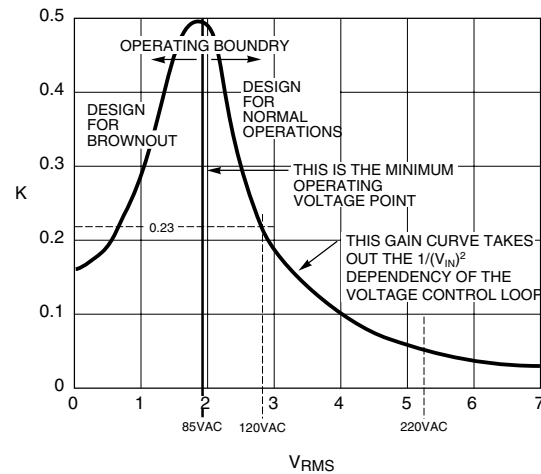

Figure 6. K-factor. Gain Modulator gain with respect to the voltage at VRMS.

The output of the gain modulator is a current which appears on IA+ to form the reference for the current error amplifier and is given as:

$$I_{GM} = K \times I_{SINE} \times (V_{EA} - 0.8)$$

where:

I_{SINE} is the current in the dropping resistor, V_{EA} is the output of the error amplifier and K is a constant determined by the V_{RMS} input.

$$I_{GM(MAX)} = \frac{2.5}{R_T}$$

The output current of the gain modulator is limited to:

This sets the system current limit. The multiplier output current is converted into the reference voltage for the current (IA) amplifier through a resistor to ground on IA+.

Figure 6 shows the gain adjuster (K) with respect to the voltage at V_{RMS} . The curve has been separated in two parts. The right hand part is for operation under normal conditions in the voltage range from minimum line voltage to maximum line voltage (90VAC to 260VAC). 85VAC on the curve has been chosen to account for tolerances. Under normal operating conditions as input voltage decreases the gain increases compensating for the drop in the loop gain.

Under brownout conditions (below 85VAC) the gain decreases to limit the amount of current that is drawn from the line thus preventing an overload condition. This is a very useful feature since in many cases the load for a PFC is a constant power load. The input current has to go high to compensate for a drop in the input voltage.

Under Voltage Lockout, OVP and Current Limit

On power-up the ML4821 remains in the UVLO condition; output low and quiescent current low. The IC becomes operational when V_{CC} reaches 16V. When V_{CC} drops below 9V, the UVLO condition is imposed. During the UVLO condition, the V_{REF} pin is “off”, making it usable as a “flag” for starting up a down-stream PWM converter.

OVP, Shutdown, and IC Bias

When the input to the OVP comparator exceeds V_{REF} , the output of the ML4821 is inhibited. The OVP input also functions as a “sleep” input, putting the IC into the low quiescent UVLO state when the OVP pin is pulled below 0.7V.

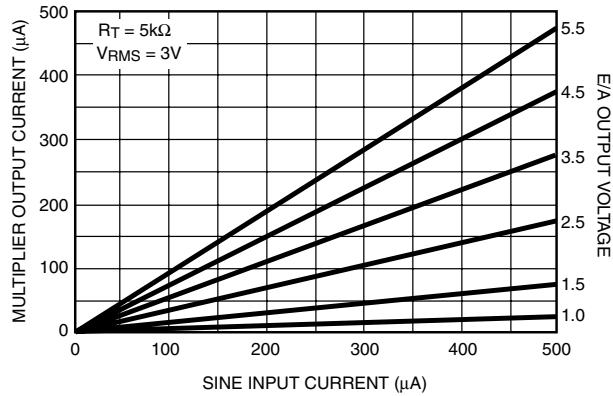

Figure 7. Gain Modulator Linearity.

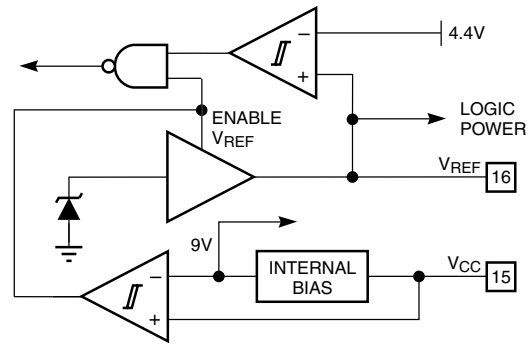

Figure 8. Under-Voltage Lockout Block Diagram.

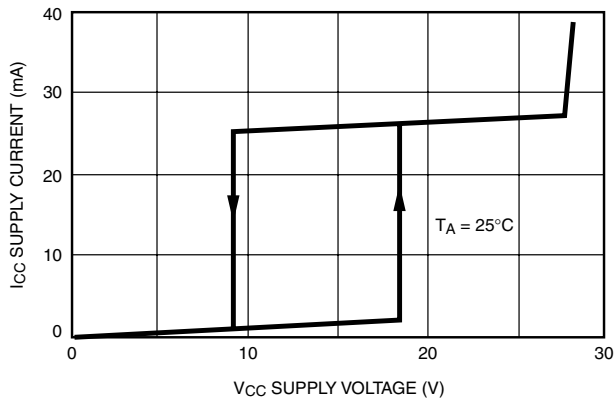

Figure 9. Total Supply Current vs. Supply Voltage.

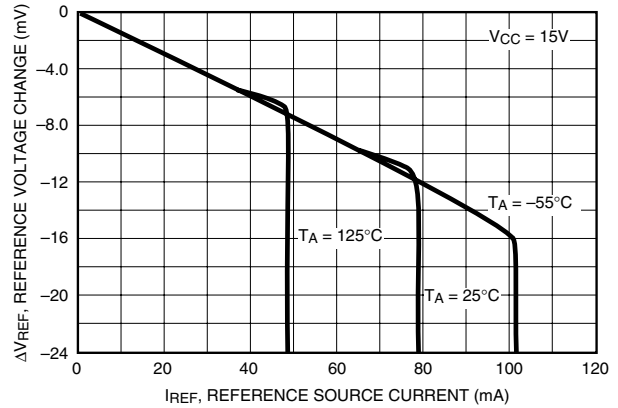

Figure 10. Reference Load Regulation.

Off-line Start-up and Bias Supply Generation

The circuit in Figure 11 supplies V_{CC} power to the ML4821. Start-up current is delivered via R10. The IC starts when V_{CC} reaches 15.5V. After that time running power is delivered through the tap on L1. The configuration shown delivers a voltage proportional to the PFC output bus voltage.

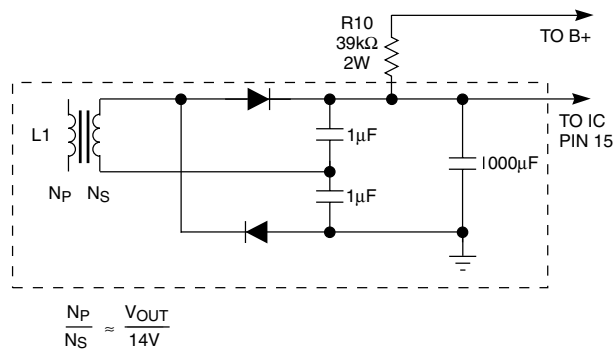

Figure 11. Bias and Start-up Circuit.

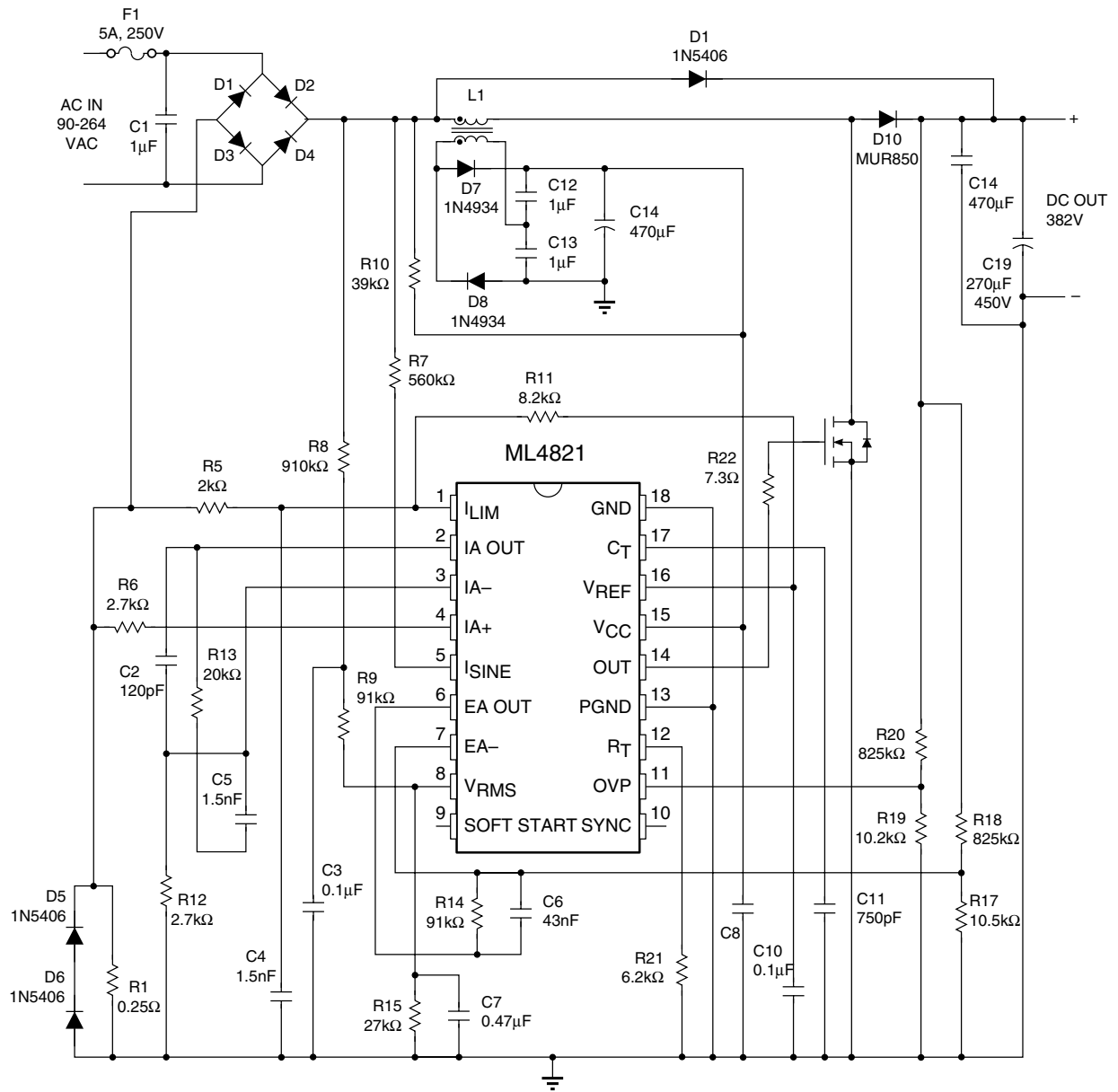
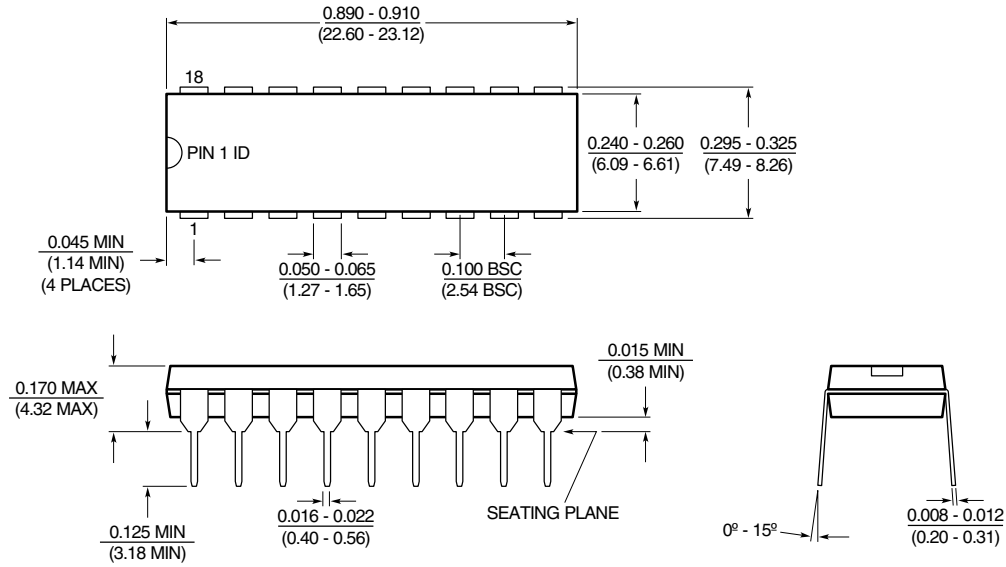

Figure 12. 200W Output PFC Circuit

Mechanical Dimensions inches (millimeters)

Package: P18
18-Pin PDIP



Package: S20
20-Pin SOIC

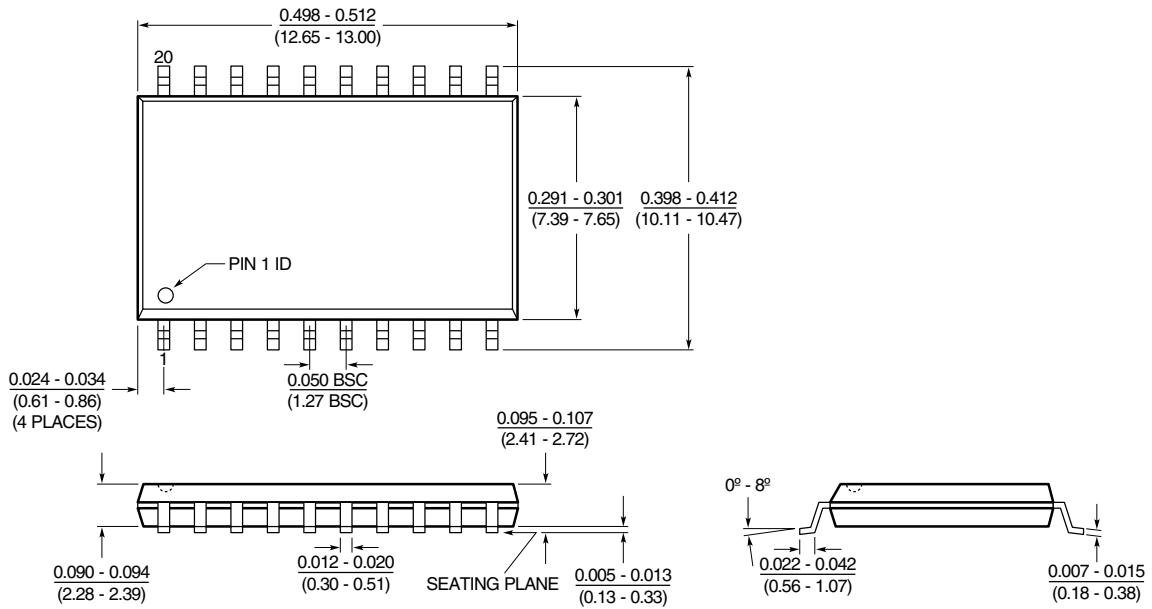

Ordering Information

| Part Number | Temperature Range | Package |
|-------------|-------------------|-------------------|
| ML4821CP | 0°C to 70°C | 18-Pin PDIP (P18) |
| ML4821CS | 0°C to 70°C | 20-Pin SOIC (S20) |

DISCLAIMER

FAIRCHILD SEMICONDUCTOR RESERVES THE RIGHT TO MAKE CHANGES WITHOUT FURTHER NOTICE TO ANY PRODUCTS HEREIN TO IMPROVE RELIABILITY, FUNCTION OR DESIGN. FAIRCHILD DOES NOT ASSUME ANY LIABILITY ARISING OUT OF THE APPLICATION OR USE OF ANY PRODUCT OR CIRCUIT DESCRIBED HEREIN; NEITHER DOES IT CONVEY ANY LICENSE UNDER ITS PATENT RIGHTS, NOR THE RIGHTS OF OTHERS.

LIFE SUPPORT POLICY

FAIRCHILD'S PRODUCTS ARE NOT AUTHORIZED FOR USE AS CRITICAL COMPONENTS IN LIFE SUPPORT DEVICES OR SYSTEMS WITHOUT THE EXPRESS WRITTEN APPROVAL OF THE PRESIDENT OF FAIRCHILD SEMICONDUCTOR CORPORATION. As used herein:

1. Life support devices or systems are devices or systems which, (a) are intended for surgical implant into the body, or (b) support or sustain life, and (c) whose failure to perform when properly used in accordance with instructions for use provided in the labeling, can be reasonably expected to result in a significant injury of the user.
2. A critical component in any component of a life support device or system whose failure to perform can be reasonably expected to cause the failure of the life support device or system, or to affect its safety or effectiveness.

Looking for pricing, stock, or lifecycle information?

Click below to explore more details on WIN SOURCE:

- ⊖ [View ML4821CS on WIN SOURCE](#)
- ⊖ [Fairchild/ON Semiconductor Information](#)

Optimize Your Supply Chain with WIN SOURCE Solutions

- ✓ Global Sourcing Solution
- ✓ Obsolete Management
- ✓ Cost Control Management
- ✓ Shortage Management
- ✓ Alternative Solution
- ✓ Excess Inventory Management