



**THE DATASHEET OF
MK74CB218RLFTR**



DUAL 1 TO 8 BUFFALO™ CLOCK DRIVER

MK74CB218

Description

The MK74CB218 Buffalo™ is a monolithic CMOS high speed clock driver. It consists of two identical single input to eight low-skew output, non-inverting clock drivers. This eliminates concerns of part to part matching in many systems. The MK74CB218 is packaged in the tiny 28-pin SSOP, which uses the same board space as the narrow 16-pin SOIC. The inputs can be connected together for a 1 to 16 fanout buffer.

A quad 1 to 4, and PECL versions, are also available. Consult IDT for more details.

The MK74CB218 can also act as a voltage translator, since it is possible to run the inputs at 3.3 V and the outputs at 2.5 V.

Features

- Packaged as 28-pin SSOP (150 mil body)
- Pb (lead) free package, RoHS compliant
- Dual one input to eight output clock drivers
- Outputs are skew matched to within 250 ps
- A outputs and B outputs matched to 250 ps
- 2.5 V or 3.3 V output voltages
- Output Enable tri-states each bank of eight
- Clock speeds up to 200 MHz

Family of IDT Parts

The MK74CB218 Buffalo™ is designed to be used with IDT's clock synthesizer devices. The inputs of the Buffalo are matched to the outputs of IDT clock synthesizers. Consult IDT for applications support.

Not recommended for new designs. See the MK74CB218B for new designs.

Block Diagram

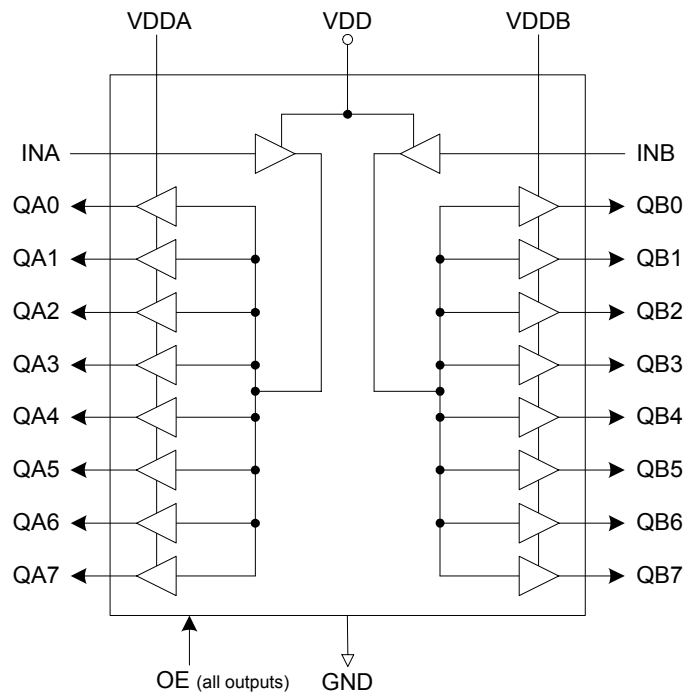

Pin Assignment

INA	□ 1	28	□ INB
QA0	□ 2	27	□ QB0
QA1	□ 3	26	□ QB1
QA2	□ 4	25	□ QB2
VDDA	□ 5	24	□ VDDB
VDDA	□ 6	23	□ VDDB
QA3	□ 7	22	□ QB3
QA4	□ 8	21	□ QB4
GND	□ 9	20	□ GND
GND	□ 10	19	□ GND
QA5	□ 11	18	□ QB5
QA6	□ 12	17	□ QB6
QA7	□ 13	16	□ QB7
OE	□ 14	15	□ VDD

Suggested Layout

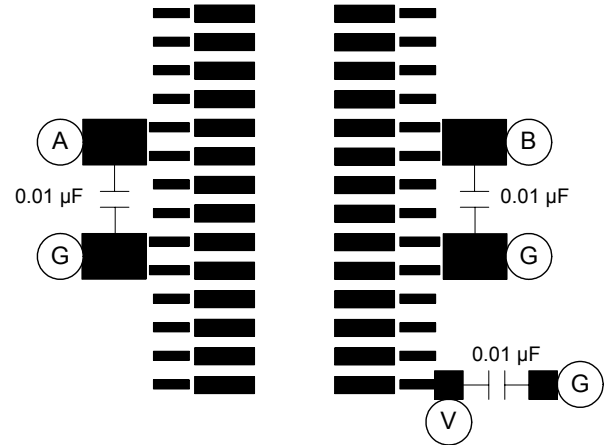

NOTE: 33 ohm series termination resistors for each output are essential for operation.

For simplicity, series termination resistors are not shown for the outputs, but should be placed as close to the device as possible. It is most critical to have the 0.01 µF decoupling capacitors closest.

(A) = connect to VDDA

(B) = connect to VDDB

(V) = connect to VDD

(G) = connect to low inductance ground plane

Pin Descriptions

Pin Number	Pin Name	Pin Type	Pin Description
1	INA	Input	Clock input for eight A outputs.
2, 3, 4	QA0, QA1, QA2	Output	Clock A outputs.
5, 6	VDDA	Power	Power supply for QA outputs. Connect to a voltage from 2.5 V to VDD. Cannot exceed VDD.
7, 8	QA3, QA4	Output	Clock A outputs.
9, 10	GND	Power	Connect to ground.
11, 12, 13	QA5, QA6, QA7	Output	Clock A outputs.
14	OE	Input	Output Enable. Tri-states all clock outputs when this input is low. Internal pull-up to VDD.
15	VDD	Power	Power supply for inputs.
16, 17, 18	QB7, QB6, QB5	Output	Clock B outputs.
19, 20	GND	Power	Connect to ground.
21, 22	QB4, QB3	Output	Clock B outputs.
23, 24	VDDB	Power	Power supply for QB outputs. Connect to a voltage from 2.5 V to VDD. Cannot exceed VDD.
25, 26, 27	QB2, QB1, QB0	Output	Clock B outputs.
28	INB	Input	Clock input for eight B outputs.

Maximum Speed

The maximum speed at which the chip can operate is limited by the power dissipation in the package. Graph 1 shows the operating frequency plotted against load capacitance per pin for a die temperature of 125°C. This is at $V_{DD} = V_{DDA} = V_{DDB} = 3.3\text{ V}$, 70°C and with 33Ω series termination resistors. The termination resistors are essential because they allow a large proportion of the total power dissipated outside the package. Reducing or eliminating the series termination will cause an increase in die temperature. It is not recommended to operate the chip at die temperatures greater than 125°C. Also note that the load capacitance per pin must include PC board parasitics such as trace capacitance.

If not all outputs of the chip are used, it is possible to operate the chip faster with larger loads. Consult IDT for your specific requirement.

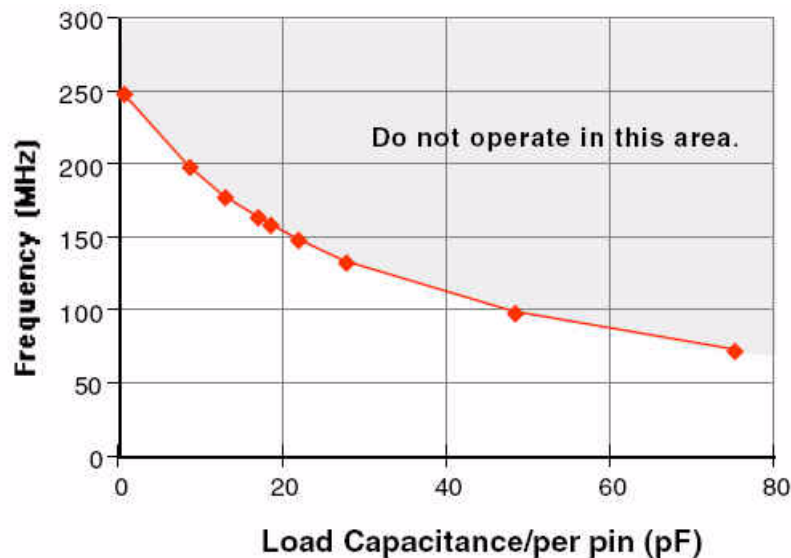

Graph 1
MK74CB218
Maximum Speed with all VDDs at 3.3V

Absolute Maximum Ratings

Stresses above the ratings listed below can cause permanent damage to the MK74CB218. These ratings, which are standard values for IDT commercially rated parts, are stress ratings only. Functional operation of the device at these or any other conditions above those indicated in the operational sections of the specifications is not implied. Exposure to absolute maximum rating conditions for extended periods can affect product reliability. Electrical parameters are guaranteed only over the recommended operating temperature range.

Item	Rating
Supply Voltage, VDD (referenced to GND)	5.2 V
All Inputs and Outputs (referenced to GND)	-0.5 V to VDD+0.5 V
Ambient Operating Temperature	0 to +70° C
Storage Temperature	-65° C to 150° C
Soldering Temperature	260° C (max. of 20 seconds)

DC Electrical Characteristics

Unless stated otherwise, VDD = 3.3 V ±10%

Parameter	Symbol	Conditions	Min.	Typ.	Max.	Units
Operating Voltage	VDD		3.0	3.3	3.6	V
Operating Voltage	VDDA or VDDB		2.375		VDD	V
Operating Supply Current	IDD	At 100 MHz, No load		75		mA
Input High Voltage	V _{IH}	INA, INB pins	0.65VDD			V
Input Low Voltage	V _{IL}	INA, INB pins			0.35VDD	V
Input High Voltage	V _{IH}	OE pin	2.0			V
Input Low Voltage	V _{IL}	OE pin			0.8	V
Output High Voltage	V _{OH}	I _{OH} = -12 mA	VDD-0.4			V
Output High Voltage	V _{OH}	I _{OH} = -25 mA	2.4			V
Output Low Voltage	V _{OL}	I _{OL} = 25 mA			0.8	V
Output High Voltage	V _{OH}	VDD = 2.5 V, I _{OH} = -16 mA	2			V
Output Low Voltage	V _{OL}	VDD = 2.5 V, I _{OL} = 16 mA			0.5	V
Output Impedance				14		Ω
Short Circuit Current		Each output, V _{OUT} =GND or VDD		100		mA
Input Capacitance	C _{IN}			7		pF
On-chip Pull-up Resistor	R _{PU}	OE		250		kΩ

Note: Short circuits may be applied indefinitely, but only one output may be shorted at a time to prevent exceeding the power dissipation rating of this package.

AC Electrical Characteristics

Unless stated otherwise, $V_{DD} = 3.3\text{ V} \pm 10\%$

Parameter	Symbol	Conditions	Min.	Typ.	Max.	Units
Input Clock Frequency	F_{IN}	Note 3	0		200	MHz
Propagation Delay, 3.3 V		With load = 15 pF		3	6	ns
Output Clock Rise Time		20% to 80%, $C_L=10\text{ pF}$		1	2	ns
Output Clock Rise Time		$V_{DD} = 2.5\text{ V}$, 20% to 80%, $C_L=10\text{ pF}$		2	3	ns
Output Clock Fall Time		80% to 20%, $C_L=10\text{ pF}$		1	2	ns
Output Clock Fall Time		$V_{DD} = 2.5\text{ V}$, 80% to 20%, $C_L=10\text{ pF}$		2	3	ns
Output Duty Cycle		$V_{DD} = 3.3\text{ V}$ or 2.5 V , $C_L=10\text{ pF}$	40	50	60	%
Output Clock Rising Edge Skew		At $V_{DD}/2$, Note 1		100	250	ps
Output Clock A to B Skew		At $V_{DD}/2$, Note 2		100	250	ps
Output Enable Time		OE high to output on			20	ns
Output Disable Time		OE low to tri-state			20	ns

Notes:

1. Between any two A outputs, or any two B outputs, with equal loading.
2. Between any clock A output and any clock B output with INA connected to INB, and equal loading.
3. See discussion and graph of speed versus load.

Thermal Characteristics

Parameter	Symbol	Conditions	Min.	Typ.	Max.	Units
Thermal Resistance Junction to Ambient	θ_{JA}	Still air		100		$^{\circ}\text{C/W}$
	θ_{JA}	1 m/s air flow		80		$^{\circ}\text{C/W}$
	θ_{JA}	3 m/s air flow		67		$^{\circ}\text{C/W}$
Thermal Resistance Junction to Case	θ_{JC}			60		$^{\circ}\text{C/W}$

Package Outline and Package Dimensions (28-pin SSOP, 150 mil Body)

Package dimensions are kept current with JEDEC Publication No. 95, MO-153

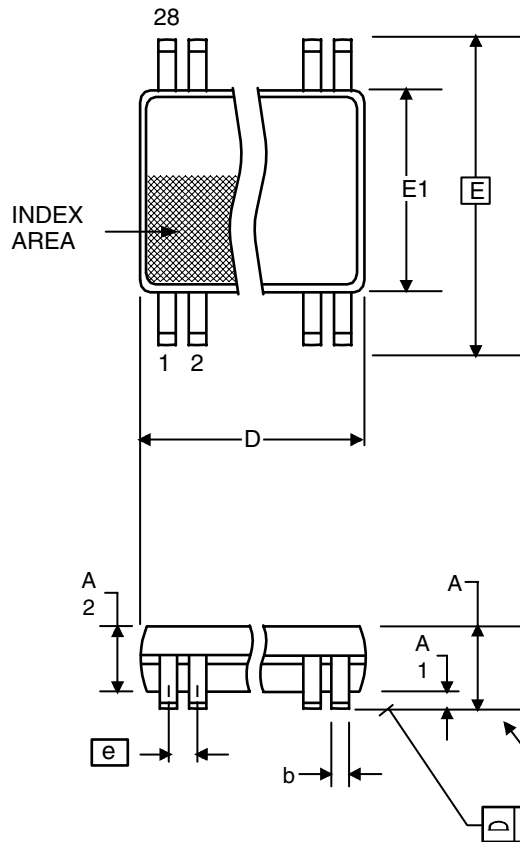

Symbol	Millimeters		Inches	
	Min	Max	Min	Max
A	1.35	1.75	.053	.069
A1	0.10	0.25	.0040	.010
A2	--	1.50	--	.059
b	0.20	0.30	.008	.012
C	0.18	0.25	.007	.010
D	9.80	10.00	.386	.394
E	5.80	6.20	.228	.244
E1	3.80	4.00	.150	.157
e	0.635 Basic		0.025 Basic	
L	0.40	1.27	.016	.050
α	0°	8°	0°	8°
aaa	--	0.10	--	0.004

Ordering Information

Part / Order Number	Marking	Shipping Packaging	Package	Temperature
MK74CB218RLF	MK74CB218RLF	Tubes	28-pin SSOP	0 to +70° C
MK74CB218RLFTR	MK74CB218RLF	Tape and Reel	28-pin SSOP	0 to +70° C

Parts that are ordered with a “LF” suffix to the part number are the Pb-Free configuration and are RoHS compliant.

While the information presented herein has been checked for both accuracy and reliability, Integrated Device Technology (IDT) assumes no responsibility for either its use or for the infringement of any patents or other rights of third parties, which would result from its use. No other circuits, patents, or licenses are implied. This product is intended for use in normal commercial applications. Any other applications such as those requiring extended temperature range, high reliability, or other extraordinary environmental requirements are not recommended without additional processing by IDT. IDT reserves the right to change any circuitry or specifications without notice. IDT does not authorize or warrant any IDT product for use in life support devices or critical medical instruments.

Innovate with IDT and accelerate your future networks. Contact:

www.IDT.com

For Sales

800-345-7015
408-284-8200
Fax: 408-284-2775

For Tech Support

www.idt.com/go/clockhelp

Corporate Headquarters

Integrated Device Technology, Inc.
www.idt.com



www.IDT.com

Looking for pricing, stock, or lifecycle information?

Click below to explore more details on WIN SOURCE:

- ⊖ [View MK74CB218RLFTR on WIN SOURCE](#)
- ⊖ [IDT, Integrated Device Technology Inc Information](#)

Optimize Your Supply Chain with WIN SOURCE Solutions

- ✓ Global Sourcing Solution
- ✓ Obsolete Management
- ✓ Cost Control Management
- ✓ Shortage Management
- ✓ Alternative Solution
- ✓ Excess Inventory Management