



# SPREAD SPECTRUM MULTIPLIER CLOCK

# MK1714-02

## Description

The MK1714-02 is a low cost, high performance clock synthesizer with selectable multipliers and percentages of spread designed to generate high frequency clocks with low EMI. Using analog/digital Phase Locked Loop (PLL) techniques, the device accepts an inexpensive, fundamental mode, parallel resonant crystal or clock input to produce a spread or dithered output. This reduces the EMI amplitude peaks at the odd harmonics by several dB. The OE pin puts both outputs into a high impedance state for board level testing. The  $\overline{PD}$  pin powers down the entire chip and the outputs are held low.

## Features

- Packaged in 20-pin tiny SSOP
- Available in Pb (lead) free package
- Operating voltage of 3.3 V or 5 V
- Multiplier modes of x1, x2, x3, x4, x5, and x6
- Inexpensive 10 - 25 MHz crystal or clock input
- OE pin tri-states the outputs for board testing
- Power down pin stops the outputs low
- Selectable frequency spread
- Spread can be turned on or off
- Advanced, low power CMOS process
- Duty cycle of 40/60
- Industrial temperature range available

**NOTE: EOL for non-green parts to occur on 5/13/10 per PDN U-09-01**

## Block Diagram

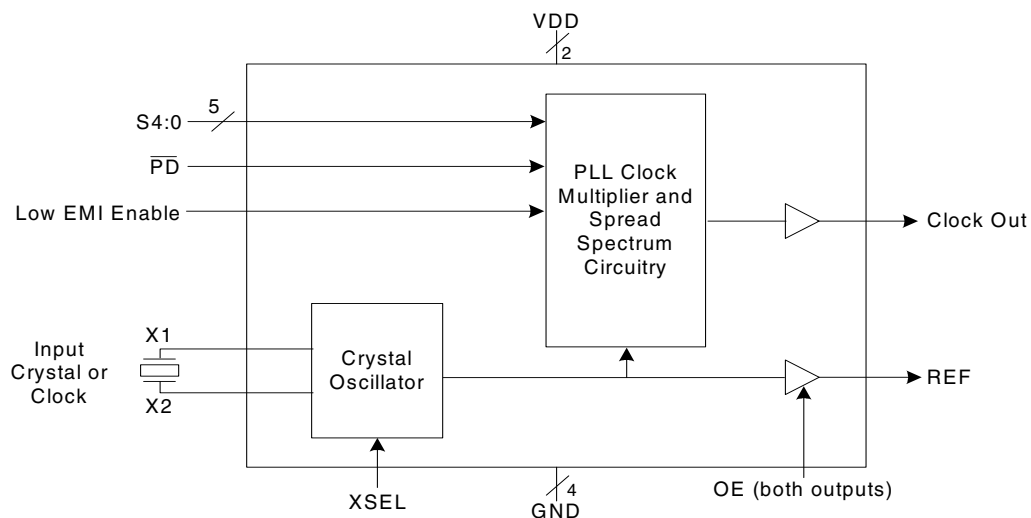

## Pin Assignment

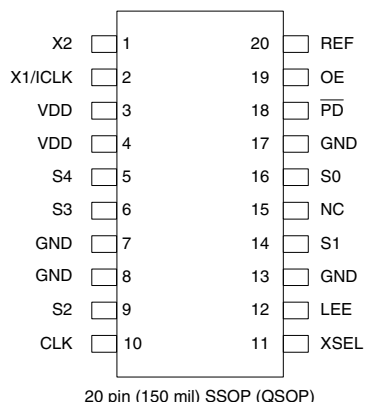

## Pin Descriptions

Pin Number	Pin Name	Pin Type	Pin Description
1	X2	XO	Crystal connection. Connect to parallel mode crystal. Leave open for clock.
2	X1	XI	Crystal connection. Connect to parallel mode crystal or clock.
3	VDD	Power	Connect to VDD. Must be same value as other VDD.
4	VDD	Power	Connect to VDD. Must be same value as other VDD.
5	S4	Input	Select pin 4. Determines multiplier and spread amount per table on following page. Internal pull-down.
6	S3	Input	Select pin 3. Determines multiplier and spread amount per table on following page. Internal pull-up.
7	GND	Power	Connect to ground.
8	GND	Power	Connect to ground.
9	S2	Input	Select pin 2. Determines multiplier and spread amount per table on following page. Internal pull-up.
10	CLK	Output	Clock output dependent on input, multiplier, and spread amount per table on following page.
11	XSEL	Input	Connect to VDD for crystal input, or GND for CLK input. Internal pull-down.
12	LEE	Input	Low EMI Enable. Turns on spread spectrum on CLK when high. Internal pull-up.
13	GND	Power	Connect to ground.
14	S1	Input	Select pin 1. Determines multiplier and spread amount per table on following page. Internal pull-up.
17	GND	Power	Connect to ground.
18	$\overline{\text{PD}}$	Input	Power down. Turns off chip when low. Outputs stop low. Leave open or connected to VDD if power down is not required.
19	OE	Input	Output enable. Tri-states all outputs when low. Internal pull-up.
20	REF	Output	Reference clock output from crystal oscillator. This clock is not spread.

Note: When changing the input frequency, the LEE pin must be set low for minimum of 10 $\mu$ s to allow the PLL to lock to the new frequency. Alternatively, the  $\overline{\text{PD}}$  pin may be set low while changing frequencies.

## Clock Output Select Table (MHz)

S4	S3	S2	S1	S0	Input Range	Multiplier	Output Range	Direction	Amount (%)	3.3/5V
0	0	0	0	0	40 - 80	x1	40 - 80	C	±0.75	Both
0	0	0	0	1	60 - 120	x1	60 - 120	DC	+0.25, -0.75	Both
0	0	0	1	0	40 - 80	x1	40 - 80	C	±1.25	Both
0	0	0	1	1	80 - 150	x1	80 - 150	C	±0.75	Both
0	0	1	0	0	10 - 30	x2	20 - 60	C	±0.75	Both
0	0	1	0	1	20 - 60	x2	40 - 120	C	±0.5	Both
0	0	1	1	0	10 - 25	x2	20 - 50	DC	+0.25, -1.5	Both
0	0	1	1	1	20 - 60	x2	40 - 120	DC	+0.5, -1	Both
0	1	0	0	0	20 - 30	x3	60 - 90	C	±0.5	Both
0	1	0	0	1	40 - 75	x2	80 - 150	C	±0.75	Both
0	1	0	1	0	40 - 100	x1	40 - 100	DC	+0.25, -1.5	Both
0	1	0	1	1	40 - 75	x2	80 - 150	DC	+0.25, -1.5	Both
0	1	1	0	0	20 - 40	x1	20 - 40	DC	+0.5, -2.0	3.3V
0	1	1	0	1	20 - 60	x1	20 - 60	DC	+0.25, -1.5	Both
0	1	1	1	0	10 - 20	x1	10 - 20	DC	+0.5, -2.0	Both
0	1	1	1	1	10 - 30	x1	10 - 30	DC	+0.25, -1.5	Both
1	0	0	0	0	20 - 37.5	x4	80 - 150	DC	+0.25, -1.25	Both
1	0	0	0	1	20 - 40	x3	60 - 120	DC	+0.25, -1.5	Both
1	0	0	1	0	10 - 30	x1	10 - 30	C	±0.75	Both
1	0	0	1	1	20 - 30	x1	20 - 30	D	-0.5	Both
1	0	1	0	0	5 - 20	x2	10 - 40	DC	+0.25, -2.25	3.3V
1	0	1	0	1	20 - 50	x3	60 - 150	D	-0.25, -2.25	Both
1	0	1	1	0	20 - 37.5	x4	80 - 150	C	±0.75	Both
1	0	1	1	1	80 - 150	x1	80 - 150	DC	+0.25, -1.25	Both
1	1	0	0	0	10 - 25	x4	40 - 100	C	±0.75	Both
1	1	0	0	1	10 - 20	x5	50 - 100	C	±0.75	Both
1	1	0	1	0	10 - 20	x6	60 - 120	C	±0.75	Both
1	1	0	1	1	20 - 50	x1	20 - 50	C	±0.75	Both
1	1	1	0	0	10 - 25	x4	40 - 100	DC	+0.25, -1.5	Both
1	1	1	0	1	10 - 20	x5	50 - 100	DC	+0.25, -1.25	Both
1	1	1	1	0	10 - 20	x6	60 - 120	D	-1.5	Both
1	1	1	1	1	10 - 30	x1	10 - 30	C	±0.75	Both

For S4:S0, 0 = connect to GND, 1 = connect to VDD.

Direction: C = center spread, D = down spread, DC = down + center spread. Amount = spread amount. For example, for a 40 MHz output clock spread down 1%, the lowest frequency is 39.60 MHz.

**Contact IDT with your exact output frequency for details on spread direction and amount.**

## External Components

The MK1714-02 requires a minimum number of external components for proper operation.

### Decoupling Capacitor

A decoupling capacitor of 0.01 $\mu$ F must be connected between VDD and GND, as close to these pins as possible. For optimum device performance, the decoupling capacitor should be mounted on the component side of the PCB. Avoid the use of vias in the decoupling circuit.

### Series Termination Resistor

When the PCB trace between the clock outputs and the loads are over 1 inch, series termination should be used. To series terminate a 50 $\Omega$  trace (a commonly used trace impedance) place a 33 $\Omega$  resistor in series with the clock line, as close to the clock output pin as possible. The nominal impedance of the clock output is 20 $\Omega$ .

## Crystal Tuning Load Capacitors

### Crystal Load Capacitors

The device crystal connections should include pads for small capacitors from X1 to ground and from X2 to ground. These capacitors are used to adjust the stray capacitance of the board to match the nominally required crystal load capacitance. Because load capacitance can only be increased in this trimming process, it is important to keep stray capacitance to a minimum by using very short PCB traces (and no vias) between the crystal and device. Crystal capacitors must be connected from each of the pins X1 and X2 to ground.

The value (in pF) of these crystal caps should equal  $(C_L - 6) * 2$ . In this equation,  $C_L$  = crystal load capacitance in pF. Example: For a crystal with a 16 pF load capacitance, each crystal capacitor would be

$$[16 - 6] * 2 = 20 \text{ pF.}$$

## PCB Layout Recommendations

For optimum device performance and lowest output phase noise, the following guidelines should be observed.

1) The 0.01 $\mu$ F decoupling capacitor should be mounted on

the component side of the board as close to the VDD pin as possible. No vias should be used between decoupling capacitor and VDD pin. The PCB trace to VDD pin should be kept as short as possible, as should the PCB trace to the ground via. Distance of the ferrite bead and bulk decoupling from the device is less critical.

2) The external crystal should be mounted just next to the device with short traces. The X1 and X2 traces should not be routed next to each other with minimum spaces, instead they should be separated and away from other traces.

3) To minimize EMI the 33 $\Omega$  series termination resistor, if needed, should be placed close to the clock output.

4) An optimum layout is one with all components on the same side of the board, minimizing vias through other signal layers (the ferrite bead and bulk decoupling capacitor can be mounted on the back). Other signal traces should be routed away from the MK1714-02. This includes signal traces just underneath the device, or on layers adjacent to the ground plane layer used by the device.

## Powerup Considerations

To insure proper operation of the spread spectrum generation circuit, some precautions must be taken in the implementation of the MK1714-02.

1) An input signal should not be applied to ICLK until VDD is stable (within 10% of its final value). This requirement can be easily met by operating the MK1714-02 and the ICLK source from the same power supply.

2) LEE should not be enabled (taken high) until after the power supplies and input clock are stable. This requirement can be met by direct control of LEE by system logic; for example, a "power good" signal. Another solution is to leave LEE unconnected to anything but a 0.01 $\mu$ F capacitor to ground. The pull-up resistor on LEE will charge the capacitor and provide approximately a 700 $\mu$ s delay until spread spectrum is enabled.

3) If the input frequency is changed during operation, disable spread spectrum until the input clock stabilizes at the new frequency.

## Absolute Maximum Ratings

Stresses above the ratings listed below can cause permanent damage to the MK1714-02. These ratings, which are standard values for IDT commercially rated parts, are stress ratings only. Functional operation of the device at these or any other conditions above those indicated in the operational sections of the specifications is not implied. Exposure to absolute maximum rating conditions for extended periods can affect product reliability. Electrical parameters are guaranteed only over the recommended operating temperature range.

Item	Rating
Supply Voltage, VDD	7V
All Inputs and Outputs	-0.5V to VDD+0.5V
Ambient Operating Temperature	-40 to +85° C
Storage Temperature	-65 to +150° C
Junction Temperature	175° C
Soldering Temperature	260° C

## Recommended Operation Conditions

Parameter	Min.	Typ.	Max.	Units
Ambient Operating Temperature	0		+70	°C
Power Supply Voltage (measured in respect to GND)	+3.0		+5.5	V

## DC Electrical Characteristics

Unless stated otherwise, VDD = 3.3 V or 5 V, Ambient Temperature -40 to +85° C

Parameter	Symbol	Conditions	Min.	Typ.	Max.	Units
Operating Voltage	VDD		3.0		5.5	V
Supply Current	IDD	No load, at 3.3 V		26		mA
	IDD	No load, at 5 V		40		mA
Input High Voltage	V <sub>IH</sub>	Select inputs, OE, $\overline{PD}$	2			V
Input Low Voltage	V <sub>IL</sub>	Select inputs, OE, $\overline{PD}$			0.8	V
Output High Voltage	V <sub>OH</sub>	I <sub>OH</sub> = -8 mA	VDD-0.4			V
Output Low Voltage	V <sub>OL</sub>	I <sub>OL</sub> = 8 mA			0.4	V
Short Circuit Current	I <sub>OS</sub>	Each output		±50		mA
On Chip Pull-up Resistor, inputs	R <sub>PU</sub>	Except X1		500		kΩ
On-Chip Pull-down Resistor, outputs	R <sub>PD</sub>	S4 pin only		500		kΩ
Input Capacitance		Except X1, X2		7		pF

## AC Electrical Characteristics

Unless stated otherwise, VDD = 3.3 V or 5 V, Ambient Temperature -40 to +85° C

Parameter	Symbol	Conditions	Min.	Typ.	Max.	Units
Input Crystal Frequency			10		25	MHz
Input Clock Frequency			10		150	MHz
Output Rise Time	$t_{OR}$	0.8 to 2.0 V			1.5	ns
Output Fall Time	$t_{OF}$	2.0 to 0.8 V			1.5	ns
One Sigma Jitter		CLK		40		ps
Absolute Jitter		CLK		±160		
Output Clock Duty Cycle		at VDD/2	40	50	60	%
Output Frequency			2		200	MHz
Output Frequency Synthesis Error				1		ppm

## Thermal Characteristics

Parameter	Symbol	Conditions	Min.	Typ.	Max.	Units
Thermal Resistance Junction to Ambient	$\theta_{JA}$	Still air		135		°C/W
	$\theta_{JA}$	1 m/s air flow		93		°C/W
	$\theta_{JA}$	3 m/s air flow		78		°C/W
Thermal Resistance Junction to Case	$\theta_{JC}$			60		°C/W

## Package Outline and Package Dimensions (20 pin SSOP, 150 Mil. Body)

Package dimensions are kept current with JEDEC Publication No. 95

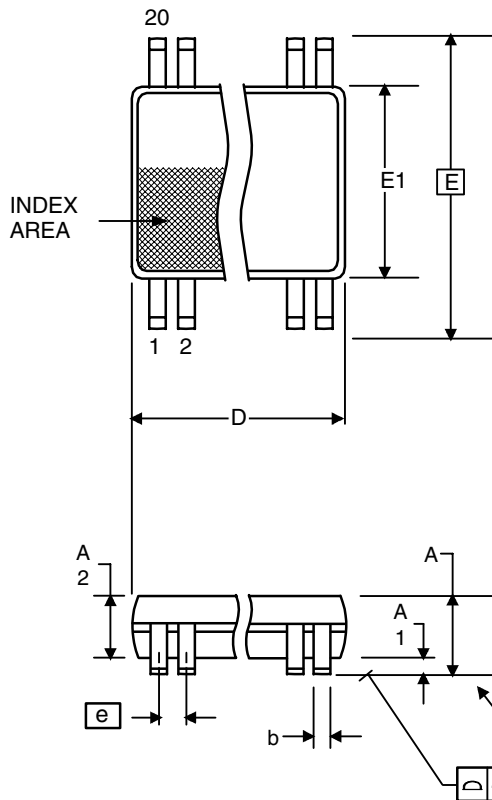

Symbol	Millimeters		Inches	
	Min	Max	Min	Max
A	1.35	1.75	.053	.069
A1	0.10	0.25	.0040	.010
A2	--	1.50	--	.059
b	0.20	0.30	0.008	0.012
C	0.18	0.25	.007	.010
D	8.55	8.75	.337	.344
E	5.80	6.20	.228	.244
E1	3.80	4.00	.150	.157
e	0.635 Basic		0.025 Basic	
L	0.40	1.27	.016	.050
$\alpha$	0°	8°	0°	8°

## Ordering Information

Part / Order Number	Marking	Shipping Packaging	Package	Temperature
MK1714-02R*	MK1714-02R	Tubes	20-pin SSOP	0 to +70° C
MK1714-01RTR*	MK1714-02R	Tape and Reel	20-pin SSOP	0 to +70° C
MK1714-02RI*	MK1714-02RI	Tubes	20-pin SSOP	-40 to 85 ° C
MK1714-02RITR*	MK1714-02RI	Tape and Reel	20-pin SSOP	-40 to 85 ° C
MK1714-02RLF	MK1714-02RL	Tubes	20-pin SSOP	0 to +70° C
MK1714-01RLFTR	MK1714-02RL	Tape and Reel	20-pin SSOP	0 to +70° C
MK1714-02RILF	MK171402RIL	Tubes	20-pin SSOP	-40 to 85 ° C
MK1714-02RILFTR	MK171402RIL	Tape and Reel	20-pin SSOP	-40 to 85 ° C

\*NOTE: EOL for non-green parts to occur on 5/13/10 per PDN U-09-01

Parts that are ordered with a "LF" suffix to the part number are the Pb-Free configuration and are RoHS compliant.

While the information presented herein has been checked for both accuracy and reliability, Integrated Device Technology (IDT) assumes no responsibility for either its use or for the infringement of any patents or other rights of third parties, which would result from its use. No other circuits, patents, or licenses are implied. This product is intended for use in normal commercial applications. Any other applications such as those requiring extended temperature range, high reliability, or other extraordinary environmental requirements are not recommended without additional processing by IDT. IDT reserves the right to change any circuitry or specifications without notice. IDT does not authorize or warrant any IDT product for use in life support devices or critical medical instruments.

Innovate with IDT and accelerate your future networks. Contact:

**www.IDT.com**

**For Sales**

800-345-7015  
408-284-8200  
Fax: 408-284-2775

**For Tech Support**

[www.idt.com/go/clockhelp](http://www.idt.com/go/clockhelp)

---

**Corporate Headquarters**

Integrated Device Technology, Inc.  
[www.idt.com](http://www.idt.com)

## Looking for pricing, stock, or lifecycle information?

Click below to explore more details on WIN SOURCE:

- ⊖ [View MK1714-02RTR on WIN SOURCE](#)
- ⊖ [IDT, Integrated Device Technology Inc Information](#)

## Optimize Your Supply Chain with WIN SOURCE Solutions

- ✓ Global Sourcing Solution
- ✓ Obsolete Management
- ✓ Cost Control Management
- ✓ Shortage Management
- ✓ Alternative Solution
- ✓ Excess Inventory Management