



**THE DATASHEET OF
MK1574-01SI**



3.3 VOLT FRAME RATE COMMUNICATIONS PLL

MK1574

Description

The MK1574 is a Phase-Locked Loop (PLL) based clock synthesizer, which accepts an 8 kHz clock input as a reference, and generates many popular communications frequencies. All outputs are frequency locked together and to the input. This allows for the generation of locked clocks to the 8 kHz backplane clock, simplifying clock generation and distribution in communications systems.

ICS manufactures the largest variety of clock generators and buffers, and can customize this device for a variety of frequencies.

Features

- 3.3 volt operation
- Packaged in 16-pin SOIC
- Accepts 8 kHz input clock
- Output clock rates include T1, E1, T2, E2
- Available in commercial (0° to +70°C) or industrial (-40 to +85°C) temperature ranges
- Available in Pb (lead) free package
- For jitter attenuation, use the MK2049
- For 5.0 V operation, use the MK1574-01A

Block Diagram

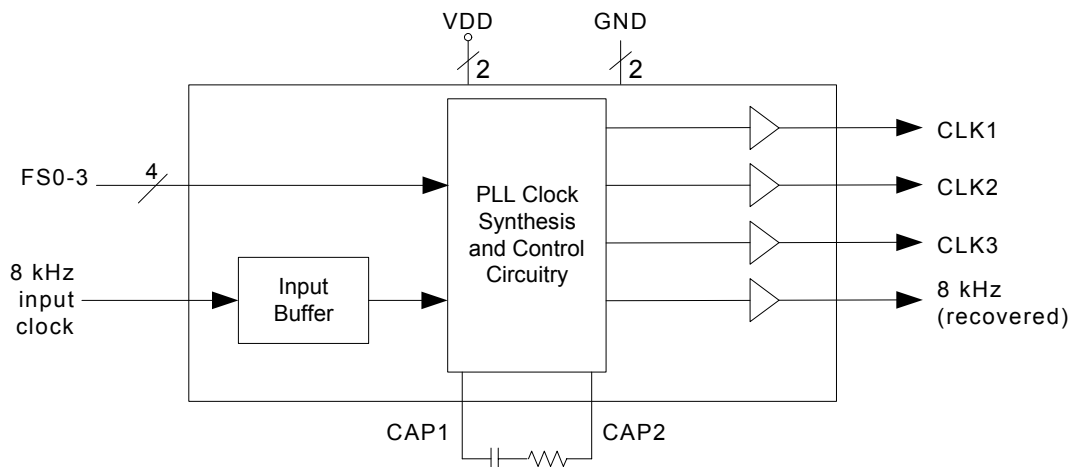

Pin Assignment

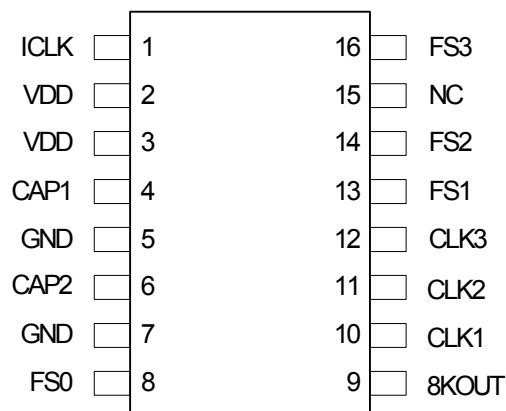

Output Clocks Decoding Table

Decode	Address	ICLK	Multiplier	CLK1	CLK2	CLK3
FS3:0	(Hex)	pin1	On-chip	pin 10	pin 11	pin 12
0000	0	Reserved	Reserved	Reserved	Reserved	Reserved
0001	1	Reserved	Reserved	Reserved	Reserved	Reserved
0010	2	Reserved	Reserved	Reserved	Reserved	Reserved
0011	3	Reserved	Reserved	Reserved	Reserved	Reserved
0100	4	8.00 kHz	2940	23.52	11.76	5.88
0101	5	8.00 kHz	1960	15.68	7.84	3.92
0110	6	8.00 kHz	2760	22.08	11.04	5.52
0111	7	8.00 kHz	2640	21.12	10.56	5.28
1000	8	8.00 kHz	1920	15.36	7.68	3.84
1001	9	8.00 kHz	6480	51.84	25.92	12.96
1010	A	8.00 kHz	2112	16.896	8.448	4.224
1011	B	8.00 kHz	1578	12.624	6.312	3.156
1100	C	8.00 kHz	8192	65.536	32.768	16.384
1101	D	8.00 kHz	6176	49.408	24.704	12.352
1110	E	8.00 kHz	1024	8.192	4.096	2.048
1111	F	8.00 kHz	772	60176	3.088	1.544

0 = connect directly to ground, 1 = connect directly to VDD.

Pin Descriptions

Pin Number	Pin Name	Pin Type	Pin Description
1	ICLK	Input	Clock input. Connect to an 8 kHz clock input.
2	VDD	Power	Connect to 3.3 V.
3	VDD	Power	Connect to 3.3 V.
4	CAP1	Input	Connect to a ceramic capacitor and a resistor in series between this pin and CAP2. Refer to the section “Loop Bandwidth and Loop Filter Component Selection”.
5	GND	Power	Connect to ground.
6	CAP2	Power	Connect to a ceramic capacitor and a resistor in series between this pin and CAP1. Refer to the section “Loop Bandwidth and Loop Filter Component Selection”.
7	GND	Power	Connect to ground.
8	FS0	Input	Frequency select 0. Determines CLK outputs per table above.
9	8KOUT	Output	Recovered 8 kHz output clock. Can be low jitter, better duty cycle than clock input.
10	CLK1	Output	Clock 1 determined by status of FS3:0 per table above.
11	CLK2	Output	Clock 2 determined by status of FS3:0 per table above.
12	CLK3	Output	Clock 3 determined by status of FS3:0 per table above.
13	FS1	Input	Frequency select 1. Determines CLK outputs per table above.
14	FS2	Input	Frequency select 2. Determines CLK outputs per table above.
15	NC	—	No connect. Do not connect anything to this pin.
16	FS3	Input	Frequency select 3. Determines CLK outputs per table above.

External Components

The MK1574 requires a minimum number of external components for proper operation. An RC network (see the section “Loop Bandwidth and Loop Filter Component Selection”) should be connected between CAP1 and CAP2 as close to the device as possible. Decoupling capacitors of 0.01 μ F should be connected between VDD and GND on pins 2, 3, 5 and 7, as close to the device as possible. A series termination resistor of 33 Ω may be used close to each clock output pin to reduce reflections.

Absolute Maximum Ratings

Stresses above the ratings listed below can cause permanent damage to the MK1574. These ratings, which are standard values for ICS commercially rated parts, are stress ratings only. Functional operation of the device at these or any other conditions above those indicated in the operational sections of the specifications is not implied. Exposure to absolute maximum rating conditions for extended periods can affect product reliability. Electrical parameters are guaranteed only over the recommended operating temperature range.

Item	Rating
Supply Voltage, VDD (referenced to GND)	-0.5 V to 7 V
All Inputs and Outputs	-0.5 V to VDD+0.5 V
Ambient Operating Temperature (commercial)	0 to +70°C
Ambient Operating Temperature (industrial)	-40 to +85°C
Storage Temperature	-65 to +150°C
Junction Temperature	150°C
Soldering Temperature	260°C

Recommended Operation Conditions

Parameter	Min.	Typ.	Max.	Units
Ambient Operating Temperature (commercial)	0		+70	°C
Ambient Operating Temperature (industrial)	-40		+85	°C
Power Supply Voltage (measured in respect to GND)	+3.13		+5.5	V

DC Electrical Characteristics

VDD = 3.3 V, Ambient temperature 0 to +70°C, unless stated otherwise

Parameter	Symbol	Conditions	Min.	Typ.	Max.	Units
Operating Voltage	VDD		3.0		3.6	V
Input High Voltage	V _{IH}		2			V
Input Low Voltage	V _{IL}				0.8	V
Output High Voltage	V _{OH}	I _{OH} = -4 mA	VDD-0.4			V
Output High Voltage	V _{OH}	I _{OH} = -25 mA	2.4			V
Output Low Voltage	V _{OL}	I _{OL} = 25 mA			0.4	V
Operating Supply Current	IDD	No Load		13		mA
Short Circuit Current	I _{OS}	Each output		±100		mA
Input Capacitance	C _{IN}			7		pF

AC Electrical Characteristics

VDD = 3.3 V, Ambient Temperature 0 to +70°C, unless stated otherwise

Parameter	Symbol	Conditions	Min.	Typ.	Max.	Units
Input Frequency	f _{IN}			8.000		kHz
Output Clock Rise Time	t _{OR}	0.8 to 2.0 V			1.5	ns
Output Clock Fall Time	t _{OF}	2.0 to 0.8 V			1.5	ns
Output Clock Duty Cycle, High time	t _{DC}	At VDD/2	40	49 to 51	60	%
Absolute Clock Period Jitter			1			ns
Actual Mean Frequency Error Versus Target (note 1)		Any clock selection		0	0	ppm

Note 1: All multipliers as shown in the table on page two are exact, and are stored in ROM on the chip.

Thermal Characteristics

Parameter	Symbol	Conditions	Min.	Typ.	Max.	Units
Thermal Resistance Junction to Ambient	θ _{JA}	Still air		120		°C/W
	θ _{JA}	1 m/s air flow		115		°C/W
	θ _{JA}	3 m/s air flow		105		°C/W
Thermal Resistance Junction to Case	θ _{JC}			58		°C/W

Loop Bandwidth and Loop Filter Component Selection

The series-connected capacitor and resistor between CAP1 and CAP2 (pins 4 and 6) determine the dynamic characteristics of the phase-locked loop. The capacitor must have very low leakage, therefore a high quality ceramic capacitor is recommended. DO NOT use any type of polarized or electrolytic capacitor. The series connected capacitor and resistor between CAP1 and CAP2 (pins 4 and 6) determine the dynamic characteristics of the phase-locked loop. The capacitor must have very low leakage, therefore a high quality ceramic capacitor is recommended. DO NOT use any type of polarized or electrolytic capacitor. Ceramic capacitors should have C0G or NP0 dielectric. Avoid high-K dielectrics like Z5U and X7R; these and other ceramics which have piezoelectric properties allow mechanical vibration in the system to increase the output jitter because the mechanical energy is converted directly to voltage noise on the VCO input.

The values of the RC network determine the bandwidth of the PLL. The values of the loop filter components are calculated using the constants K1 and K2 from the Loop Filter Constants table (page 7). The loop bandwidth is set by the capacitor C and the constant K1 using the formula:

$$BW \text{ (Hz)} = \frac{K1}{\sqrt{C}} \quad \text{Equation 1}$$

The loop damping is set by the resistor R, the capacitor C, and the constant K2 using the formula::

$$R = \frac{\zeta * K2}{\sqrt{C}} \quad \text{Equation 2; } \zeta \text{ (zeta) is the damping factor}$$

For example, to design the loop filter whewn generating 8.192 MHz from 8 kHz:

1. From the Output Clock Decoding table (page 2), the address is E. The Loop Filter Constants table (page 7) shows the constants K1 = 0.0516 and K2 = 6.2.
2. A good value for the loop bandwidth is 1/20 the input frequency; where 8 kHz/20 = 400 Hz. Using equation 1,

$$400 = \frac{K1}{\sqrt{C}}$$

Therefore,

$$C = \left(\frac{0.0516}{400} \right)^2 = 16.6 \text{ nF (16 nF nearest standard value)}$$

3. A good value for the damping factor ζ is 0.707. From equation 2,

$$R = \frac{0.707 * 6.2}{\sqrt{16E-9}} = 34.7 \text{ k}\Omega \text{ (36 k}\Omega \text{ nearest standard value)}$$

Loop Filter Constants

This table shows the constants K1 and K2 that are used with the equations on page 6 to calculate the external loop filter components.

Loop Filter Constants for MK1574-01

Decode	Address	Loop Filter Constants	
FS3:0	(Hex)	K1	K2
0000	0	Reserved	Reserved
0001	1	Reserved	Reserved
0010	2	Reserved	Reserved
0011	3	Reserved	Reserved
0100	4	0.0430	7.4
0101	5	0.0527	6.0
0110	6	0.0444	7.2
0111	7	0.0454	7.0
1000	8	0.0533	6.0
1001	9	0.0410	7.8
1010	A	0.0508	6.3
1011	B	0.0587	5.4
1100	C	0.0365	8.7
1101	D	0.0420	7.6
1110	E	0.0516	6.2
1111	F	0.0594	5.4

PC Board Layout

A proper board layout is critical to the successful use of the MK1574. In particular, the CAP1 and CAP2 pins are very sensitive to noise and leakage (CAP1 at pin 4 is the most sensitive). Traces must be as short as possible and the capacitor and resistor must be mounted next to the device as shown to the right. The capacitor connected between pins 3 and 5 is the power supply decoupling capacitor. The high frequency output clocks on may benefit from a series 33Ω resistor connected close to the pin (not shown).

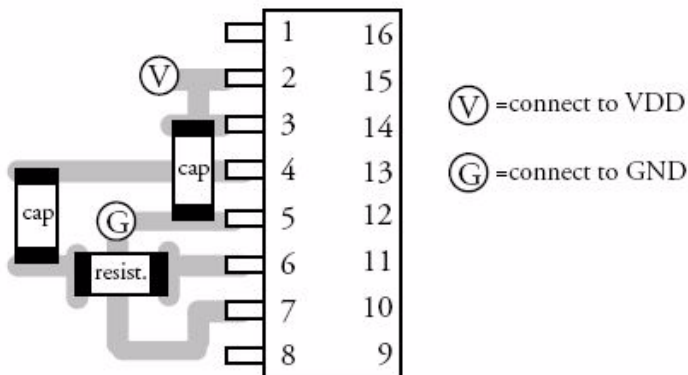

Clock Multipliers/Accuracies

In the table on page 2 are the actual multipliers stored in the MK1574 ROM, which yield the exact values shown for the output clocks.

Package Outline and Package Dimensions (16-pin SOIC, 150 Mil. Narrow Body)

Package dimensions are kept current with JEDEC Publication No. 95

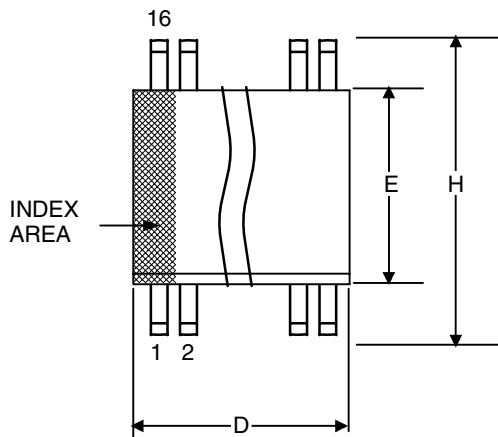

Symbol	Millimeters		Inches	
	Min	Max	Min	Max
A	1.35	1.75	.0532	.0688
A1	0.10	0.25	.0040	.0098
B	0.33	0.51	.013	.020
C	0.19	0.25	.0075	.0098
D	9.80	10.00	.3859	.3937
E	3.80	4.00	.1497	.1574
e	1.27 BASIC		0.050 BASIC	
H	5.80	6.20	.2284	.2440
h	0.25	0.50	.010	.020
L	0.40	1.27	.016	.050
α	0°	8°	0°	8°

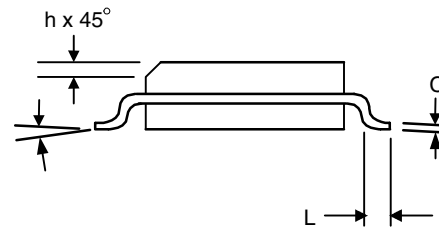
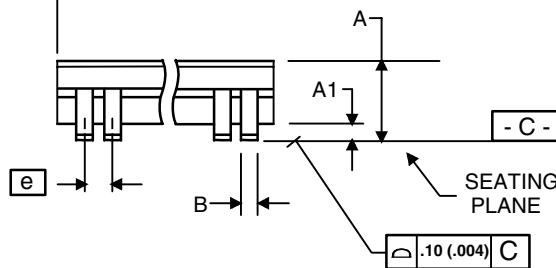

Ordering Information

Part / Order Number	Marking	Shipping Packaging	Package	Temperature
MK1574-01S	MK1574-01S	Tubes	16-pin SOIC	0 to +70° C
MK1574-01STR	MK1574-01S	Tape and Reel	16-pin SOIC	0 to +70° C
MK1574-01SLF	MK1574-01SLF	Tubes	16-pin SOIC	0 to +70° C
MK1574-01SLFTR	MK1574-01SLF	Tape and Reel	16-pin SOIC	0 to +70° C
MK1574-01SI	MK1574-01SI	Tubes	16-pin SOIC	-40 to +85° C
MK1574-01SITR	MK1574-01SI	Tape and Reel	16-pin SOIC	-40 to +85° C
MK1574-01SILF	MK1574-01SILF	Tubes	16-pin SOIC	-40 to +85° C
MK1574-01SILFTR	MK1574-01SILF	Tape and Reel	16-pin SOIC	-40 to +85° C

Parts that are ordered with a "LF" suffix to the part number are the Pb-Free configuration and are RoHS compliant.

While the information presented herein has been checked for both accuracy and reliability, Integrated Circuit Systems (ICS) assumes no responsibility for either its use or for the infringement of any patents or other rights of third parties, which would result from its use. No other circuits, patents, or licenses are implied. This product is intended for use in normal commercial applications. Any other applications such as those requiring extended temperature range, high reliability, or other extraordinary environmental requirements are not recommended without additional processing by ICS. ICS reserves the right to change any circuitry or specifications without notice. ICS does not authorize or warrant any ICS product for use in life support devices or critical medical instruments.

Innovate with IDT and accelerate your future networks. Contact:

www.IDT.com

For Sales

800-345-7015
408-284-8200
Fax: 408-284-2775

For Tech Support

<product line email>
<product line phone>

Corporate Headquarters

Integrated Device Technology, Inc.
6024 Silver Creek Valley Road
San Jose, CA 95138
United States
800 345 7015
+408 284 8200 (outside U.S.)

Asia Pacific and Japan

Integrated Device Technology
Singapore (1997) Pte. Ltd.
Reg. No. 199707558G
435 Orchard Road
#20-03 Wisma Atria
Singapore 238877
+65 6 887 5505

Europe

IDT Europe, Limited
Prime House
Barnett Wood Lane
Leatherhead, Surrey
United Kingdom KT22 7DE
+44 1372 363 339



www.IDT.com

Looking for pricing, stock, or lifecycle information?

Click below to explore more details on WIN SOURCE:

- ⊖ [View MK1574-01SI on WIN SOURCE](#)
- ⊖ [IDT, Integrated Device Technology Inc Information](#)

Optimize Your Supply Chain with WIN SOURCE Solutions

- ✓ Global Sourcing Solution
- ✓ Obsolete Management
- ✓ Cost Control Management
- ✓ Shortage Management
- ✓ Alternative Solution
- ✓ Excess Inventory Management