



# THE DATASHEET OF MICRF405YML-TR





## MICRF405

290MHz – 980MHz ISM Band  
ASK / FSK Transmitter



RadioWire®

### General Description

The MICRF405 is a 290MHz-980MHz RF transmitter IC designed for unlicensed ISM band operations. It's designed to work in the North American 315MHz and 915MHz bands as well as the European 433MHz and 868MHz bands. The device is fully FCC Part 15.247 and EN300-220-compliant.

The transmitter consists of a FSK/ASK modulator, PLL frequency synthesizer and a power amplifier. The frequency synthesizer consists of a voltage-controlled oscillator (VCO), a crystal oscillator, dual modulus prescaler, programmable frequency dividers and a phase-detector. The loop-filter can be internal or external. The output power of the power amplifier can be programmed to eight levels. A lock detect circuit detects when the PLL is in lock.

In FSK mode, the user can select between three different modulation types allowing a data rate up to 200kbps. When selecting FSK modulation applied with dividers, the MICRF405 is switching between to sets of register values (M0,N0,A0:"0" and M1,N1 and A1:"1"). The second modulation type is closed loop VCO modulation using the internal modulator that applies the modulated data to the VCO. The third FSK modulation type is Open loop VCO modulation.

In ASK modulation, the user can select between two modulation types, with or without spreading. In both modes the modulation depth is programmable.

### Features

- FSK/ASK transmitter
- Frequency programmable
- ASK modulation depth programmable
- High efficiency power amplifier
- Programmable output power
- Power down function
- MCU reference clock
- Base band package engine
- TX buffer
- No external tuning circuitry

### Applications

- Meter reading
- Automotive
- Smart Home
- Remote control systems
- Residential Automation
- Wireless security system

MicroLead Frame and MLF are registered trademarks of Amkor Technologies  
RadioWire is a registered trademark of Micrel, Inc.

Micrel Inc. • 2180 Fortune Drive • San Jose, CA 95131 • USA • tel +1 (408) 944-0800 • fax + 1 (408) 474-1000 • <http://www.micrel.com>

## Table of Contents

General Description .....	1
Features .....	1
Applications .....	1
Table of Contents .....	2
Ordering Information .....	3
Block Diagram .....	3
Pin Configuration .....	4
Absolute Maximum Ratings <sup>(1)</sup> .....	5
Operating Ratings <sup>(2)</sup> .....	5
Electrical Characteristics .....	5
Electrical Characteristics (cont.) .....	6
Data and Configuration Interface .....	7
Programming Interface Timing .....	8
Writing to the Control Registers in MICRF405 .....	9
What to write: .....	9
How to write: .....	9
The two different ways to “program the chip” are: .....	9
Writing to a Single Register .....	9
How to write: .....	9
Writing to All Registers .....	10
What to write .....	10
How to write: .....	10
Writing to n Registers Having Incremental Addresses .....	10
What to write .....	11
Writing to n Registers Having Non-Incremental Addresses .....	12
Reading from the Control Registers in MICRF405 .....	12
Reading from the Interrupt Register .....	12
Data Interface and Data Transfer .....	13
Packet Engine Overview: .....	14
How to transmit a Packet with the Packet Engine: .....	15
Programming Summary .....	17
Main Modes of Operation .....	18
Power Amplifier .....	18
Frequency Synthesizer .....	19
Crystal Oscillator (XCO) .....	21
VCO .....	22
Charge Pump and PLL Filter .....	24
Modulation .....	27
Bit rate settings .....	30
Modulator .....	30
Deviation setting .....	31
Shaping .....	31
Modulator saturation .....	31
Lock Detect .....	32
Low Dropout Regulator (LDO) and Low Battery Detector .....	33
Bit Description .....	34
Typical Application Circuit .....	42
Package Information .....	45

### Ordering Information

Part Number	Junction Temp. Range <sup>(1)</sup>	Package
MICRF405YML	-40° to +125°C	PB-Free 24-Pin MLF <sup>®</sup>

### Block Diagram

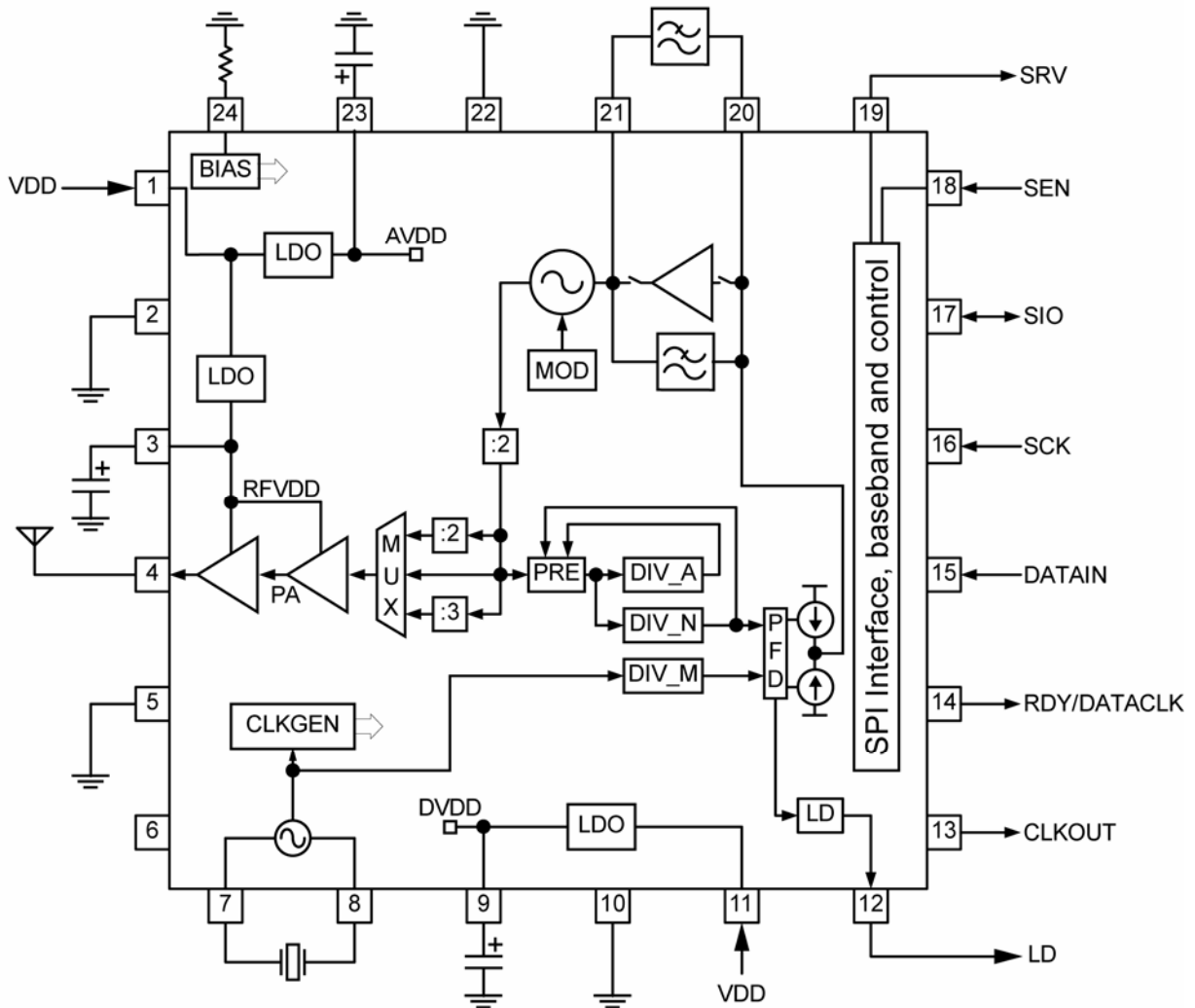

## Pin Configuration

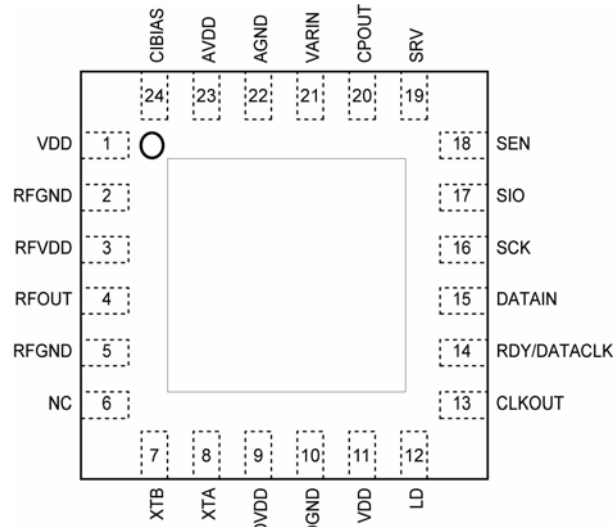

24-Pin MLF® (Top View)

Pin Number	Pin Name	Type	Pin Function
1	VDD		VDD
2	RFGND		RF Ground
3	RFVDD		RF VDD
4	RFOUT	O	RF output
5	RFGND		RF Ground
6	NC		Not connected
7	XTB	O	Crystal oscillator output
8	XTA	I	Crystal oscillator input
9	DVDD		Digital VDD
10	DGND		Digital ground
11	VDD		VDD
12	LD	O	Lock Detect output
13	CLKOUT	O	Programmable Clock output
14	RDY/DATACLK	O	Transmit buffer Ready / Alternative Data clock
15	DATAIN	I	Alternative Data input
16	SCK	I	SPI clock
17	SIO	I/O	Serial input/output
18	SEN	I	Serial programming interface enable
19	SRV	O	Service interrupt pin
20	CPOUT	O	Charge pump output
21	VARIN	I	VCO varactor input
22	AGND		Analog ground
23	AVDD		Analog VDD
24	CIBIAS	O	Bias
25	HEATSINK		Ground

### Absolute Maximum Ratings<sup>(1)</sup>

Supply Voltage (V <sub>DD</sub> ).....	+3.7V
Voltage on any pin <sup>(3)</sup> (GND = 0V)...	-0.3V to 3.7V
Lead Temperature (soldering, 20sec.).....	260°C
Storage Temperature (T <sub>s</sub> ).....	-55°C to +150°C
ESD Rating <sup>(4)</sup>	
All pins except pin 4.....	2 kV
Pin 4 (RFOUT).....	200 V

### Operating Ratings<sup>(2)</sup>

Supply voltage (V <sub>IN</sub> ).....	+2.2V to +3.6V
RF Frequencies.....	290MHz to 980MHz
Data Rate (NRZ) .....	200kbps
Ambient Temperature (T <sub>A</sub> ) .....	-40°C to +125°C
Package Thermal Resistance	
MLF <sup>®</sup> (Θ <sub>JA</sub> ) .....	41.7°C/W

### Electrical Characteristics

f<sub>RF</sub> = 915MHz. V<sub>DD</sub> = 3.0V; T<sub>A</sub> = 25°C, bold values indicate -40°C ≤ T<sub>A</sub> ≤ +125°C, unless noted.

Parameter	Condition	Min	Typ	Max	Units
RF Frequency Operating Range	Freq_band=0	<b>290</b>		<b>325</b>	MHz
	Freq_band=1	<b>430</b>		<b>490</b>	MHz
	Freq_band=2-3	<b>860</b>		<b>980</b>	MHz
Power Supply		<b>2.2</b>		<b>3.6</b>	V
Power Down Current			0.3		μA
Standby Current	ClkOut_en=0		200		μA
PLL mode current	PA2-0=000, PA off		5.6		mA
<b>VCO and PLL Section</b>					
Reference Frequency		<b>4</b>		<b>40</b>	MHz
PLL startup	1kHz loop filter bandwidth, Fphd=200kHz		7.0		ms
	3kHz loop filter bandwidth, Fphd=500kHz		1.8		ms
	30kHz loop filter bandwidth, Fphd=1000kHz		140		μs
Standby-TX (PA on) 30kHz bandwidth			200		μs
Crystal Oscillator Start-Up Time	16MHz, 9pF load, XCO_Fast=1		300		μs
Charge Pump Current	V <sub>CPOUT</sub> = 1.2V, CP_CUR = 3		100		μA
<b>Transmit Section</b>					
Output Power	R <sub>LOAD</sub> = 250Ω, Pa2-0=111		10		dBm
	R <sub>LOAD</sub> = 250Ω, Pa2-0=001		-7		dBm
Output Power Tolerance	Over temperature range		1.5		dB
	Over power supply range		3.0		dB
Tx Current Consumption	R <sub>LOAD</sub> = 150Ω, PA2-0=111		18		mA
	R <sub>LOAD</sub> = 150Ω, PA2-0=001		9.6		mA
	R <sub>LOAD</sub> = 150Ω, PA2-0=000		5.6		mA
Modulation depth ASK/OOK	ASK=7 (OOK)		60		dB
	ASK=6		20		dB
Binary FSK Frequency Deviation <sup>(5)</sup>	Bitrate = 200kbps			<b>300</b>	kHz
Data Rate <sup>(5)</sup>	VCO modulation	<b>20</b>		<b>200</b>	kbps
	Divider modulation			<b>20</b>	kbps
	ASK			<b>50</b>	kbps

## Electrical Characteristics (cont.)

Parameter	Condition	Min	Typ	Max	Units
Occupied bandwidth	FSK 38.4kbps, $\beta = 2$ , bandwidth for 99.5% of total power, RBW=10kHz		130		kHz
	FSK 125kbps, $\beta = 2$ , bandwidth for 99.5% of total power, RBW=30kHz		425		kHz
	FSK 200kbps, $\beta = 2$ , bandwidth for 99.5% of total power, RBW=100kHz		750		kHz
	ASK (OOK) 38.4kbps, bandwidth for 99.5% of total power, RBW=10kHz		200		kHz
	ASK 20dB modulation depth, 38.4kbps, bandwidth for 99% of total power, RBW=10kHz		120		kHz
2 <sup>nd</sup> Harmonic	Measured with matching network		-36		dBm
3 <sup>rd</sup> Harmonic			-54		dBm
Spurious Emission<1GHz				-54	dBm
Spurious Emission>1GHz				-41	dBm
LO Leakage				-80	dBm

### Notes:

1. Exceeding the absolute maximum rating may damage the device.
2. The device is not guaranteed to function outside its operating rating.
3. On the pins RFVDD (3), PTATBIAS (6), DVDD (9), CPOUT (20), VARIN (21) and AVDD (23), the maximum input voltage should not exceed 2.75V.
4. Devices are ESD sensitive. Handling precautions recommended. Pin 4, RFOUT, has less ESD protection (Human body model (HBM) of 200V and Charged Device Model (CDM) of 500V).
5. Guaranteed by design.

## Data and Configuration Interface

The user interface of the MICRF405 is a serial peripheral interface (SPI) consisting of Serial interface enable (SEN), Serial data input/output (SIO) and Serial clock (SCK). This user interface is used for MICRF405 configuration setup and can also be used for sending the user data. A second option is to transmit data bitwise using the DATAIN pin. The RDY/DATACLK pin is used to synchronize the data transfers.

The control word consists of 30 addressable bytes and defines the way of operations as well as transmitting data. Table 1 shows all 30 bytes. The values specified are the default setup, which are preset after power up. The first register is the

desktop register controlling the state of the 405, the PA and clock-out for the microcontroller. The next block of 10bytes sets the output radio frequency through the dividers A, N and M. The bytes with address 11 to 21 set the frequency band, modulation type, bit rate, loop filter type and bandwidth, XCO tuning etc. This block is not frequently used as these settings are usually static application dependent. Address 22 and 23 are mostly test bits, and are seldom altered from default settings in applications. The interrupt register, which is located at address 24, is read only (writing to it will not do any harm or have any effect). The last 5 bytes are used when transferring user data to transmit through the SPI. The first four set the SyncID field in the packet, and the last is the one byte data buffer.

Adr	Data							
	D7	D6	D5	D4	D3	D2	D1	D0
0000000	Mode1=0	Mode0=1	PA2=1	PA1=1	PA0=1	ClkOut_en=1	Sync_en=1	Load_en=1
0000001	-	-	A0_5=0	A0_4=0	A0_3=1	A0_2=1	A0_1=1	A0_0=0
0000010	-	-	-	-	N0_11=0	N0_10=0	N0_9=0	N0_8=0
0000011	N0_7=0	N0_6=1	N0_5=1	N0_4=1	N0_3=0	N0_2=0	N0_1=1	N0_0=1
0000100	-	-	-	-	M0_11=0	M0_10=0	M0_9=0	M0_8=0
0000101	M0_7=0	M0_6=0	M0_5=1	M0_4=0	M0_3=0	M0_2=0	M0_1=0	M0_0=1
0000110	-	-	A1_5=0	A1_4=1	A1_3=1	A1_2=1	A1_1=1	A1_0=1
0000111	-	-	-	-	N1_11=0	N1_10=0	N1_9=0	N1_8=0
0001000	N1_7=0	N1_6=1	N1_5=1	N1_4=0	N1_3=1	N1_2=1	N1_1=1	N1_0=1
0001001	-	-	-	-	M1_11=0	M1_10=0	M1_9=0	M1_8=0
0001010	M1_7=0	M1_6=0	M1_5=1	M1_4=0	M1_3=0	M1_2=0	M1_1=0	M1_0=0
0001011	LowBatt_en=1	Freq_Band1=0	Freq_Band0=1	VCO_freq2=0	VCO_freq1=1	VCO_freq0=1	Modulation1=1	Modulation0=0
0001100	LowBatt_level=0	LDO_by=0	LDO_en1=1	LDO_en0=1	MOD_LDc_en=0	PA_FEc_en=0	PA_LDc_en=0	LD_en=1
0001101	Bit_IO_en=1	Manchester_en=0	Sel_CRC1=1	Sel_CRC0=1	SyncID_Len1=0	SyncID_Len0=1	Pream_Len1=1	Pream_Len0=0
0001110	Mod_I4=0	Mod_I3=1	Mod_I2=0	Mod_I1=0	Mod_I0=1	Mod_A2=0	Mod_A1=1	Mod_A0=1
0001111	VCO_Fr_Chk=0	VCO_Fr_Auto=0	FSKn2=1	FSKn1=0	FSKn0=0	Mod_F2=1	Mod_F1=0	Mod_F0=0
0010000	0	Prescaler_Sel=0	FSKClk_K5=1	FSKClk_K4=1	FSKClk_K3=0	FSKClk_K2=1	FSKClk_K1=0	FSKClk_K0=0
0010001	ASK_PN_en=0	ASK_EN=0	ASKshape2=1	ASKshape1=1	ASKshape0=1	ASK2=1	ASK1=1	ASK0=1
0010010	ASKn1=1	ASKn0=0	ASKClk_K5=1	ASKClk_K4=1	ASKClk_K3=0	ASKClk_K2=1	ASKClk_K1=0	ASKClk_K0=0
0010011	INT_LF_EN=1	CP_CUR1=0	CP_CUR0=1	LF_RES1_4=0	LF_RES1_3=1	LF_RES1_2=0	LF_RES1_1=0	LF_RES1_0=1
0010100	LF_High_PM=1	LF_CAP1=1	LF_CAP0=1	LF_RES3_4=0	LF_RES3_3=0	LF_RES3_2=1	LF_RES3_1=0	LF_RES3_0=1
0010101	ClkOut_1=0	ClkOut_0=0	XCO_Fast=1	XCOtune4=1	XCOtune3=0	XCOtune2=0	XCOtune1=0	XCOtune0=0
0010110	INT_LF_TEST=0	VCO_IB2=0	VCO_IB1=0	VCO_IB0=0	VCO_by=0	OUTS2=0	OUTS1=0	OUTS0=0
0010111	PA_IB3=1	PA_IB2=0	PA_IB1=0	PA_IB0=1	PAB_IB3=1	PAB_IB2=0	PAB_IB1=0	PAB_IB0=1
0011000	VCO_freq_O2	VCO_freq_O1	VCO_freq_O0			VC_HI	VC_LO	LOW_BATT
0011001	SyncID3_7=1	SyncID3_6=1	SyncID3_5=1	SyncID3_4=0	SyncID3_3=0	SyncID3_2=1	SyncID3_1=0	SyncID3_0=1
0011010	SyncID2_7=1	SyncID2_6=1	SyncID2_5=1	SyncID2_4=0	SyncID2_3=0	SyncID2_2=1	SyncID2_1=0	SyncID2_0=1
0011011	SyncID1_7=1	SyncID1_6=1	SyncID1_5=1	SyncID1_4=0	SyncID1_3=0	SyncID1_2=1	SyncID1_1=0	SyncID1_0=1
0011100	SyncID0_7=1	SyncID0_6=1	SyncID0_5=1	SyncID0_4=0	SyncID0_3=0	SyncID0_2=1	SyncID0_1=0	SyncID0_0=1
0011101	DATA_7	DATA_6	DATA_5	DATA_4	DATA_3	DATA_2	DATA_1	DATA_0

Table 1. Controlword MICRF405 (values preset at power-up).

**Programming Interface Timing**

Figure 1 and Table 2 shows the timing specification for the 3-wire serial programming interface.

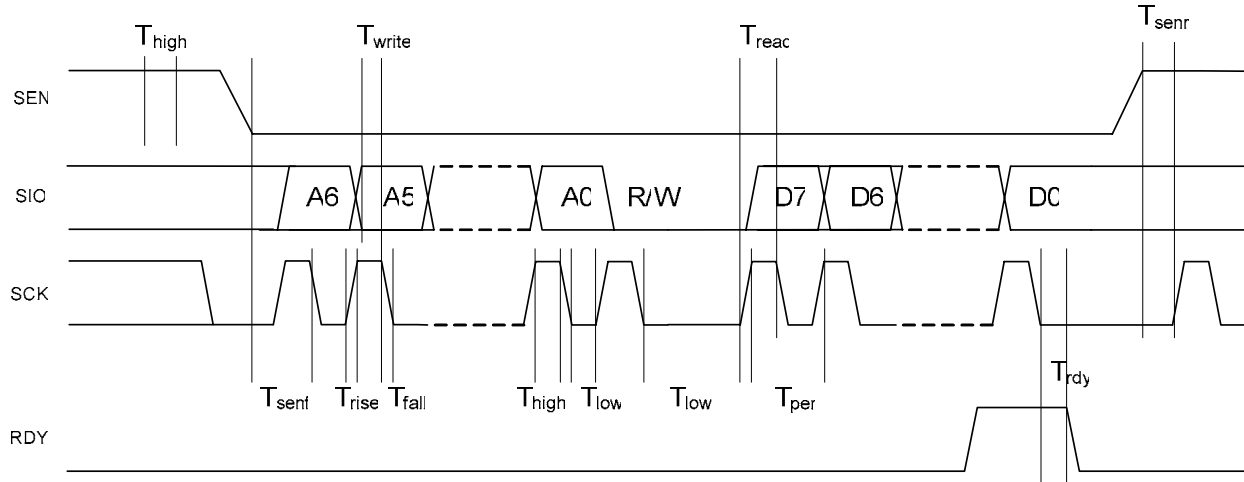

**Figure 1. Programming Interface Timing.**

Symbol	Parameter	Values			Units
		Min.	Typ.	Max.	
T <sub>per</sub>	Min. period of SCK	50			ns
T <sub>high</sub>	Min. high time of SCK	20			ns
T <sub>low</sub>	Min. low time of SCK	20			ns
T <sub>fall</sub>	Max. time of falling edge of SCK			1	μs
T <sub>rise</sub>	Max. time of rising edge of SCK			1	μs
T <sub>senf</sub>	Min. time of falling edge of SEN to falling edge of SCK	0			ns
T <sub>senr</sub>	Min. delay from rising edge of SEN to rising edge of SCK	5			ns
T <sub>write</sub>	Min. delay from valid SIO to falling edge of SCK during a write operation	0			ns
T <sub>read</sub>	Min. delay from rising edge of SCK to valid SIO during a read operation (assuming load capacitance of SIO is 25pF)	75			ns
T <sub>rdy</sub>	Min. delay from falling edge of SCK (last bit of byte into data buffer) to falling edge of RDY	20			ns
T <sub>high</sub>	Min. duration of a SEN high pulse (F <sub>phd</sub> is the phase detector frequency)	1/F <sub>phd</sub>			
	Time from power up to first falling edge of SEN			3.5	ms

**Table 2. Timing Specification for the 3-wire Programming Interface.**

### Writing to the Control Registers in MICRF405

Writing: A number of octets are entered into MICRF405 followed by a load-signal to activate the new setting. Making these events is referred to as a "write sequence." It is possible to update all, 1, or n control registers in a write sequence. The address to write to (or the first address to write to) can be any valid address (0-29). The SIO line is always an input to the MICRF405 (output from user) when writing.

Field	Comments
Address:	A 7-bit field, ranging from 0 to 29. MSB is written first.
R/W bit:	A 1-bit field, = "0" for writing
Values:	A number of octets (1-30 octets). MSB in every octet is written first. The first octet is written to the control register with the specified address (= "Address"). The next octet (if there is one) is written to the control register with address = "Address + 1" and so on.

**Table 3. Writing to the Control Registers.**

#### How to write:

Bring SEN low to start a write sequence. The active state of the SEN line is "low". Use the SCK/SIO serial interface to clock in "Address" and "R/W" bit and "Values" into the MICRF405. MICRF405 will sample the SIO line at negative edges of SCK. Make sure to change the state of the SIO line before the negative edge, for instance on positive edge. Refer to Figure 2.

Bring SEN inactive to make an internal load-signal and complete the write-sequence. Note: there is an exception to this point. If the programming bit called "load\_en" (D0 in ControlRegister0) is "0", then no load pulse is generated.

Field	Comments
Address:	7 bit = A6, A5, ...A0 (A6 = MSB. A0 = LSB)
R/W bit:	"0" for writing
Values:	8 bits = D7, D6, ...D0 (D7 = MSB, D0 = LSB)

**Table 4. When writing to a Single Register, totally 2 octets are clocked into the MICRF405.**

#### How to write:

- Bring SEN low
- Use SCK and SIO to clock in the 2 octets
- Bring SEN high

#### What to write:

- The address of the control register to write to (or if more than 1 control register should be written to, the address of the 1st control register to write to).
- A bit to enable reading or writing of the control registers. This bit is called the R/W bit.
- The values to write into the control register(s).

#### The two different ways to "program the chip" are:

- Write to a number of control registers (0-29) when the registers have incremental addresses (write to 1, all or n registers)
- Write to a number of control registers when the registers have non-incremental addresses.

#### Writing to a Single Register

Writing to a control register with address "A6, A5, ...A0" is described here. During operation, writing to 1 register is sufficient to change the way the transmitter works. Typical example: Change from transmit mode to power-down.

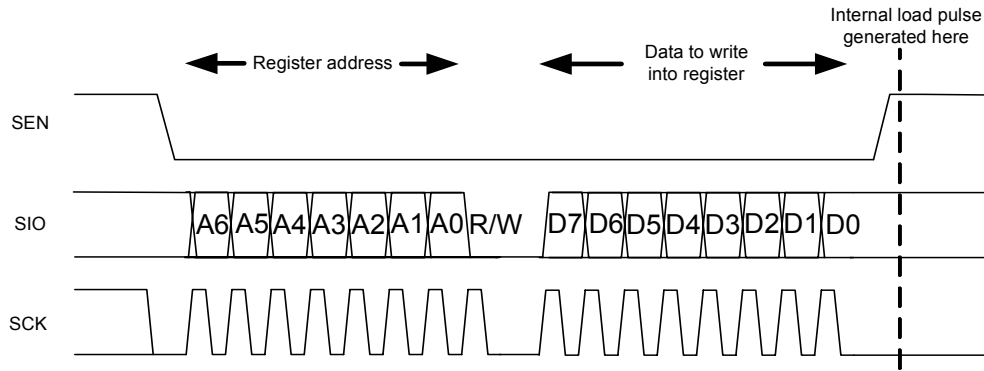

Figure 2. Writing to One Address.

In Figure 2, SIO is changed at positive edges of SCK. The MICRF405 samples the SIO line at negative edges. The value of the R/W bits is always "0" for writing.

**Writing to All Registers**

Writing to all register can be done at any time. To get the simplest firmware, always write to all registers. The price to pay for the simplicity is increased write-time, which leads to increased time to change the way the MICRF405 works. If data is transferred through DATAIN pin write address 0-23 (address 24-29 is don't care). If data is transferred through SPI write address 0-28 (Address 29 is only written to during data transfer, not during configuration).

**What to write**

Field	Comments
Address:	'0000000' (address of the first register to write to, which is 0)
R/W bit:	"0" for writing
Values:	1 <sup>st</sup> Octet: wanted values for ControlRegister0. 2 <sup>nd</sup> Octet: wanted values for ControlRegister1 and so on for all of the octets.

Table 5. When writing to All Registers, totally 25/30 (5 are optional) octets are clocked into the MICRF405.

**How to write:**

- Bring SEN low
- Use SCK and SIO to clock in the 25/30 octets
- Bring SEN high

Refer to Figure 3. Writing to n Registers Having Incremental Addresses.

**Writing to n Registers Having Incremental Addresses**

In addition to entering all bytes, it is also possible to enter a set of n bytes, starting from address i = "A6, A5, ... A0". Typical example: Clock in a new set of frequency dividers (i.e. change the RF frequency). Registers to be written are located in i, i+1, i+2.

**What to write**

Field	Comments
Address:	7 bit = A6, A5, ...A0 (A6 = MSB. A0 = LSB) (address of first byte to write to)
R/W bit:	"0" for writing
Values:	n* 8 bits = D7, D6, ...D0 (D7 = MSB, D0 = LSB) (written to control reg. with address "i") D7, D6, ...D0 (D7 = MSB, D0 = LSB) (written to control reg. with address "i+1")  D7, D6, ...D0 (D7 = MSB, D0 = LSB) (written to control reg. with address "i+n-1")

**Table 6. When writing to Registers having Incremental Addresses, totally 1+n octets are clocked into the MICRF405.**

**How to write:**

- Bring SEN low
- Use SCK and SIO to clock in the 1 + n octets
- Bring SEN high

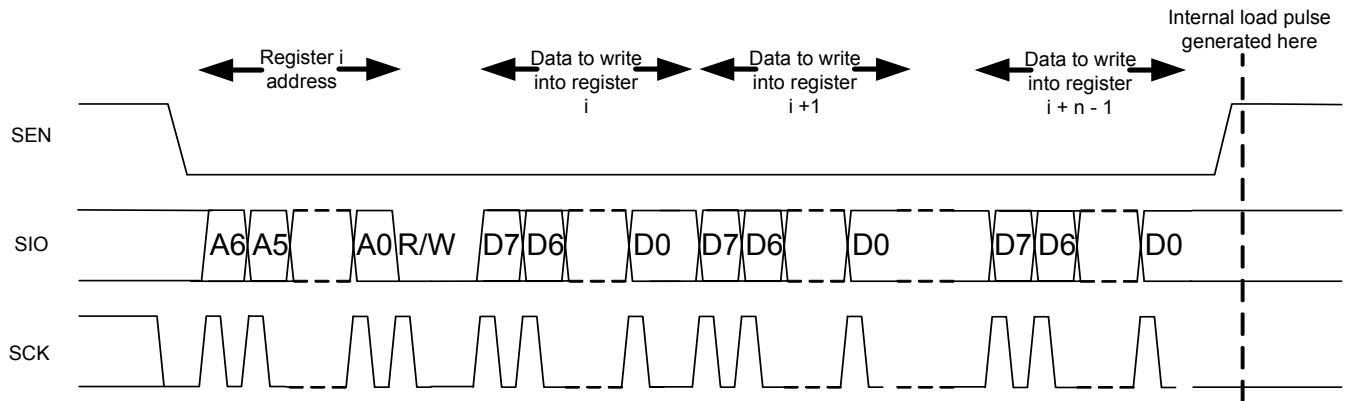

**Figure 3. Writing to n Registers Having Incremental Addresses.**

### Writing to n Registers having Non-Incremental Addresses

Registers with non-incremental addresses can be written to in one write-sequence as well. Example of non-incremental addresses: "0,1,3". However, this requires more overhead, and the user should consider the possibility to make a "continuous" update, for example, by writing to "0,1,2,3" (writing the present value of "2" into "2"). The simplest firmware is achieved by always writing to all registers. Refer to previous sections.

This write-sequence is divided into several sub-parts:

- Disable the generation of load-signals by clearing bit "load\_en" (D0 in ControlRegister0)
- Repeat for each group of register having incremental addresses:
  - Bring SEN active
  - Enter first address for this group, R/W bit and values
  - Bring SEN inactive
- Finally, enable and make a load-signal by setting "load\_en"

Refer to the previous sections for how to write to 1 or n (with incremental addresses) registers in the MICRF405.

### Reading from the Control Registers in MICRF405

The "read-sequence" is:

1. Enter address and R/W bit
2. Change direction of SIO line
3. Read out a number of octets and change SIO direction back again.

It is possible to read all, 1 or n registers. The address to read from (or the first address to read from) can be any valid address (0-29). Reading is not destructive, i.e., values are not changed. The SIO line is output from the MICRF405 (input to user) for a part of the read-sequence. Refer to procedure description below.

A read-sequence is described for reading n registers, where n is number 1-30.

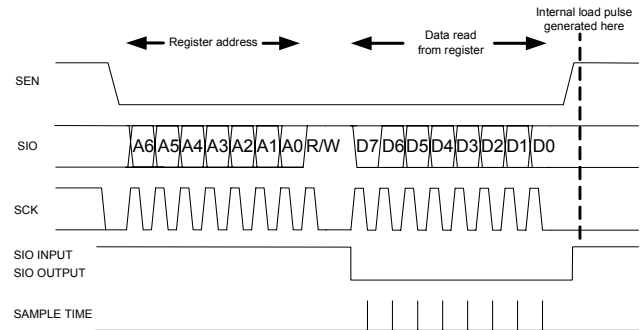

Figure 4. Reading from a Control Register.

In Figure 4 above, 1 register is read. The address is A6, A5, ... A0. A6 = MSB. The data read out is D7, D6, ... D0. The value of the R/W bit is always "1" for reading.

- Bring SEN low
- Enter address to read from (or the first address to read from) (7 bits) and
- The R/W bit = 1 to enable reading
- Make the SIO line an input to the user (set pin in tristate)
- Read n octets. The first rising edge of SLK will set the SIO as an output from the MICRF405. The 405 will change the SIO line at positive edges of SCK. The user should read the SIO line at the negative edges.
- Make the SIO line an output from the user again.

### Reading from the Interrupt Register

If any of the interrupts, Vc\_HI, Vc\_LO or Low\_Batt, is set the SRV pin will go high. Read the interrupt register, address 24, to see which interrupts are flagged. It is possible to read this register at all times, for instance, to read the tuned VCO\_FREQ setting which is also stored at the same address. When rising SEN after having read the register, the internal load pulse will then clear all interrupt flags. To keep the flags when reading it, it is therefore necessary to set LOAD\_en=0 before hand.

## Data Interface and Data Transfer

Adr	Data							
	D7	D6	D5	D4	D3	D2	D1	D0
0000000	Mode1=0	Mode0=1	PA2=1	PA1=1	PA0=1	ClkOut_en=1	Sync_en=1	Load_en=1
0001100	LowBatt_level=0	LDO_by=0	LDO_en1=1	LDO_en0=1	MOD_LDc_en=0	PA_FEc_en=0	PA_LDc_en=0	LD_en=1
0001101	Bit_IO_en=1	Manchester_en=0	Sel_CRC1=1	Sel_CRC0=1	SyncID_Len1=0	SyncID_Len0=1	Pream_Len1=1	Pream_Len0=0
0011001	SyncID3_7=1	SyncID3_6=1	SyncID3_5=1	SyncID3_4=0	SyncID3_3=0	SyncID3_2=1	SyncID3_1=0	SyncID3_0=1
0011010	SyncID2_7=1	SyncID2_6=1	SyncID2_5=1	SyncID2_4=0	SyncID2_3=0	SyncID2_2=1	SyncID2_1=0	SyncID2_0=1
0011011	SyncID1_7=1	SyncID1_6=1	SyncID1_5=1	SyncID1_4=0	SyncID1_3=0	SyncID1_2=1	SyncID1_1=0	SyncID1_0=1
0011100	SyncID0_7=1	SyncID0_6=1	SyncID0_5=1	SyncID0_4=0	SyncID0_3=0	SyncID0_2=1	SyncID0_1=0	SyncID0_0=1
0011101	DATA_7	DATA_6	DATA_5	DATA_4	DATA_3	DATA_2	DATA_1	DATA_0

There are two main data interfaces; bit-wise and byte oriented. The bit-wise interface use the DATAIN (always input to the 405) and DATACLK pin (always output from the 405). This interface is enabled with the Bit\_IO\_en="1". If Sync\_en=1 bit-wise synchronous mode is selected and data clock is provided on the RDY/DATACLK pin. In this mode, the MICRF405 will sample the bit on the DATAIN pin on the positive edge of the DATACLK. It is therefore important that the MCU toggle the DATAIN pin on negative edge of the DATACLK, See Figure 5. No packet engine, CRC or Manchester encoding is available in bit-wise data interface. To select asynchronous mode set Sync\_en="0". If VCO modulation is selected, the DATAIN pin in tri-state (MCU pin=input) until first bit is about to be transmitted (see VCO modulation).

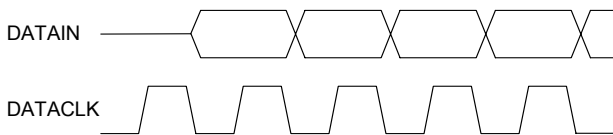

Figure 5. Synchronous Data Interface.

If Bit\_IO\_en=0, the byte wise interface is selected and data is transferred byte wise through the one byte buffer (register address 29). The register is accessed the same way as the other register, as explained in the previous sections. The only difference is that it is instantly valid and do not need any load pulse. This also applies to the SyncID registers, address 25-28. When writing to address 29, the address counter will not increment which means several bytes can be written into the buffer without raising SEN and setting up a new write session. The RDY/DATACLK pin will provide byte synchronization. The data byte buffer is ready for refill on falling edges on RDY. In this mode of data transfer, Sync\_en must be set.

The data in the buffer is fed into a packet engine with an optional CRC calculation and Manchester encoding. The virtual wire packet structure is shown in Table 7. The preamble, SyncID field and CRC field are automatically generated by the packet engine. The user needs only to enter frame length and payload for each packet. The preamble bytes are equal to 10101010, and the number of preamble bytes are given by 1+Pream\_Len[1:0] (D1:D0 ControlRegister13). Next field is the SyncID which is 1-4 bytes long set by the SyncID\_Len[1:0] bits. The content of the SyncID bytes are fully programmable and specified in the SyncID0-3 bytes. The SyncID0 byte, address 28, is sent first, and the SyncID3 byte, address 25, is sent last. Refer to Table 8. The frame length byte follows the SyncID field. It specifies length of the payload and CRC. Finally, the CRC field ends the packet. The SelCRC\_0 bit specifies the length of the CRC field. If it is set, a 2 byte ITU-T CRC (start condition 00h) is calculated of the payload and sent. If SelCRC\_0=0, an 8 bit CCITT CRC is calculated of the payload and sent. Either two cases assuming SelCRC\_1=1. If SelCRC\_1=0, no CRC is calculated on chip, and the user must calculate this on the microcontroller and include it in the payload. A Manchester encoder is available on chip. It is activated if the Manchester\_en bit is set. It encodes the complete packet. The codes are "10" for "0" and "01" for "1". The preamble byte is automatically set 0 in this mode, as this will produce the desired 10101010-pattern when Manchester encoded. Note that on-the-air data rate will be twice the bit rate set by the FSKClk\_K/FSKn or ASKClk\_K/ASKn, which specifies the actual throughput. Because of this, FSKn needs to be greater than zero if VCO modulation is selected, Modulation[1:0]<2.

Preamble	SyncID	Frame length	Payload	CRC
1-4 bytes	1-4 bytes	1 byte	2/2/1-253/254/255 bytes	2/1/0 bytes

**Table 7. Virtual Wire Packet Structure Overview.**

SyncID_Len	SyncID_Len	Start of transmitted packet. Leftmost byte transmitted first					
0	0	Preamble	SyncID0	Frame length			
0	1	Preamble	SyncID0	SyncID1	Frame length		
1	0	Preamble	SyncID0	SyncID1	SyncID2	Frame length	
1	1	Preamble	SyncID0	SyncID1	SyncID2	SyncID3	Frame length

**Table 8. Virtual Wire Packet Structure, SyncID field.**

#### Packet Engine Overview:

- Preamble generated by packet engine: 1-4 bytes equal 10101010. Length set by Pream\_Len[1:0]
- SyncID field added by packet engine: 1-4 bytes of user defined content. Length set by SyncID\_Len[1:0]. Content set in registers SyncID0, SyncID1, SyncID2 and SyncID3, address 28-25.
- The frame length is entered by user for each packet. Specify the length of the payload and CRC fields in bytes, ranging from 2 to (255 ÷ # CRC bytes). # CRC bytes can be 0 to 2.
- For each payload byte, wait for falling edge of RDY before writing the byte into the DATA register.
- The optional CRC field ends the packet. Its length is programmable 0, 1 or 2 bytes by the Sel\_CRC[1:0].

How to transmit a Packet with the Packet Engine:

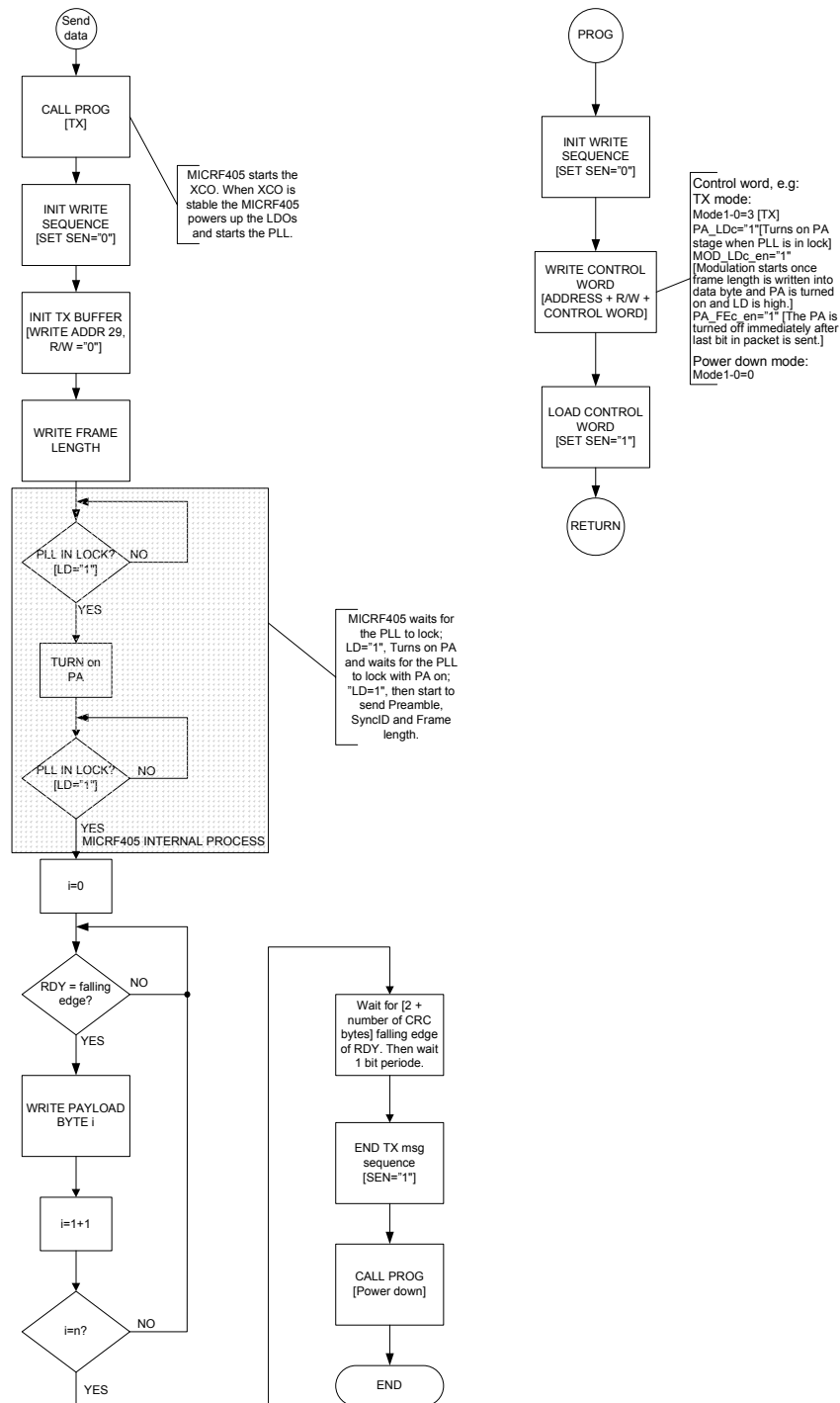

Figure 6. Flowchart of Transmitting a Packet Using the Packet Engine.

The sequence of a typically packet transfer is shown in Figure 7.

1. Set the 405 in transmit mode with the correct settings by writing in the TX control word. Once SEN is pulled high, the internal load will activate the new settings. The 405 will now start the PLL and turn on the PA (if PA\_LDc\_en is set)
2. Pull SEN low, and address the TX buffer. Address=29+R/W, RW="0".
3. Write the frame length into the data buffer. On the 8<sup>th</sup> falling edge of SCK, clocking in the last bit, the modulation will start. If MOD\_LDc\_en is not set, check that lock detect (LD) is high after PA is turned on before writing last bit (or the complete byte 3). If MOD\_LDc\_en=1, finish steps 2 and 3 immediately after step 1. The MICRF405 will now wait until the transmitter is ready (PLL tuned in, PA on and LD high) before starting to modulate. In either case, the packet engine will start to transmit the desired preamble and SyncID bytes once the modulation starts.
4. When the last bit of the last SyncID byte is being sent, the RDY signal is high. After the falling edge of RDY, the packet engine is sending the frame length, and the buffer is then ready for refill. The time between 3 and 4 will vary depending, upon the bit rate and desired number of bytes in the preamble and SyncID field. The first RDY pulse will, however, notify the user when to enter the 1<sup>st</sup> byte of the payload. Step four is repeated for all the bytes in the payload, meaning [frame length – number of CRC bytes] times. It is important that the buffer is refilled after the falling edge of RDY and before the next falling edge of RDY.
5. In this step, all user data is received in the 405 and it transmits the last part of the packet. This means that the SEN now can be pulled high at any time, closing the write session. If PA\_LDc\_en=1 and load\_en=1, it is then necessary to leave SEN low until the end of packet. This is because raising SEN will generate a load pulse, and this, in turn, causes the PA\_LDc function to turn off the PA for a short period of time. The RDY signal will be high when the last bit of the payload is being sent, but there is now no need to refill the buffer. Also, if CRC is enabled, then RDY will be high during the last bit of each of the CRC bytes being sent. Because of an internal sampling the actual RF output lags 1 bit period, which means the modulation will stop one bit period after the last RDY pulse.
6. The frame is now completely transmitted. If PA\_FEc\_en=1, the PA will be automatically turned off immediately after last bit in packet is transmitted. The PLL will, however, remain running. (This state is equal to MODE[1:0]=3 (TX), PA\_LDc\_en=0 and PA[2:0]=0.) If PA\_FEc\_en=0 the PA will remain on until it is turned off by the MODE or PA bits. In step 6, the buffer is ready for a new packet. Any 8bits entered into the buffer in this sections is thought of as a new frame length, refer back to Section 3. This, assuming the MICRF405 remains in TX (MODE[1:0]=3). In this case, and when PA\_FEc\_en=1, the PA will be turned on once the 8<sup>th</sup> bit is clocked in. It is recommended to use the MOD\_LDc function in this case as it will delay the modulation until the PLL has stabilized after the PA is turned on. If not the start of the modulation will be distorted and may interfere the settling of the PLL due to PA turn on (please see chapter Lock Detect).

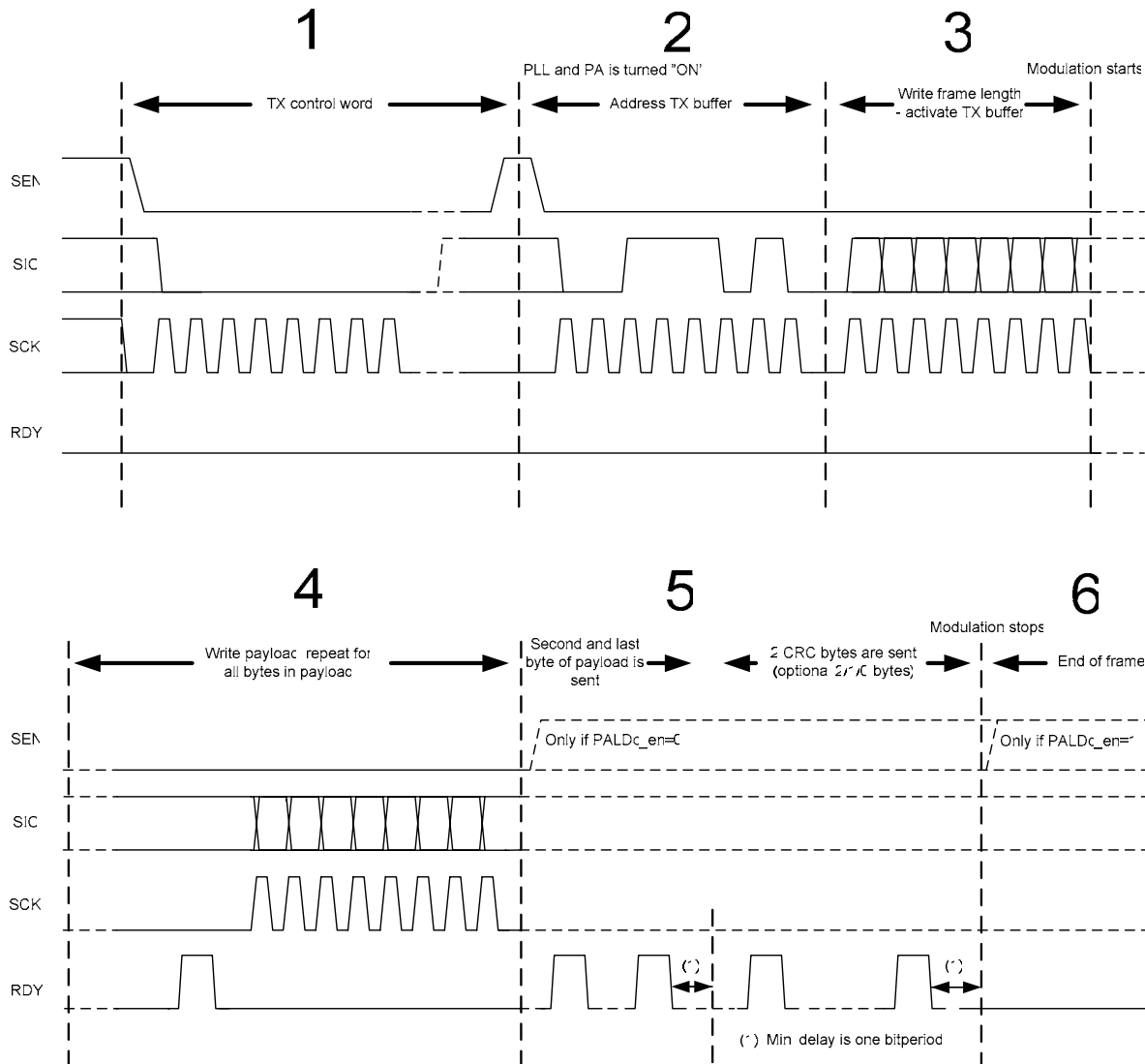

Figure 7. Sequence of a Typical Packet Transfer.

**Programming Summary**

- Use SEN, SCK, and SIO to get access to the control registers in MICRF405.
- SCK is user-controlled.
- Write to the MICRF405 on positive edges (MICRF405 reads on negative edges).
- Read from the MICRF405 on negative edges (MICRF405 writes on positive edges)
- Address field is 7 bits long. Enter MSB first.
- R/W bit is "1" for read and "0" for write.
- Address and R/W bit together make 1 octet
- Enter/read MSB in every octet first.
- Always write 8 bits to/read 8 bits from a control register. This is the case for registers with less than 8 used bits as well.
- Writing: Bring SEN low, write address and R/W bit followed by the new values to fill into the addressed control register(s) and bring SEN high for loading, i.e. activation of the new control register values ("Load\_en" = 1).

## Main Modes of Operation

Adr	Data							
A6..A0	D7	D6	D5	D4	D3	D2	D1	D0
0000000	Mode1=0	Mode0=1	PA2=1	PA1=1	PA0=1	ClkOut_en=1	Sync_en=1	Load_en=1

There are three main modes of operation and these are controlled by Mode1-0, see Table 9. In “Power down” mode all blocks are shut down, though the contents of the registers are preserved. In “Standby” the crystal oscillator is running and an optional programmable clock is present on the CLKOUT pin (Default enabled). This clock can be used as a micro-controller reference frequency. In “TX” mode all blocks are active if not disabled by the user.

Mode1	Mode0	State	Comments
0	0	Power down	Keeps Register configuration
0	1	Standby	Crystal Oscillator running
1	0		
1	1	Transmit mode	Transmit mode

Table 9. MICRF405 Main Modes.

## Power Amplifier

Adr	Data							
A6..A0	D7	D6	D5	D4	D3	D2	D1	D0
0000000	Mode1=0	Mode0=1	PA2=1	PA1=1	PA0=1	ClkOut_en=1	Sync_en=1	Load_en=1
0010111	PA_IB3=1	PA_IB2=0	PA_IB1=0	PA_IB0=1	PAB_IB3=1	PAB_IB2=0	PAB_IB1=0	PAB_IB0=1

The maximum output power is approximately 10dBm. For maximum output power the load seen by the PA must be resistive and around 150Ω at 900MHz and 250Ω at 434MHz and 315Hz. The output power can be programmed with bits PA[2:0] to eight different levels if bit PA\_LDc\_en=1 or seven levels if PA\_LDc\_en=0, with approximately 3dB between each step. If PA\_LDc\_en=0, the PA is turned off by setting PA[2:0] to 0. For all other PA[2:0] combinations, the PA is on and has a maximum power when PA[2:0]=7. If PA\_LDc\_en=1 the PA is controlled by the lock detector.

A simple π LC network can be used to provide the

needed impedance and also to reduce the power of the harmonics to acceptable levels. Such matching networks for different frequencies are shown on the Typical Application Circuit.

The bias setting of the PA and the PA buffer is controlled by bits PA\_IB PA[2:0] and PAB\_IB PA[2:0]. The recommended bit setting, shown in Table 10, is for the different frequency bands.

Typical values of output power and current consumption for the different power levels for different frequencies are shown in Table 11. The settings used are: Modulation[2:0]=2, ClkOut\_en=0, external loop filter.

Frequency band (MHz)	PA_IB[2:0]	PAB_IB[2:0]
315	8	8
434	9	8
868	9	9
915	10	9

Table 10. Recommended Settings of PA\_IB and PAB\_IB vs. Frequency Band.

Power level (PAx)	915MHz		434MHz		315MHz	
	P <sub>out</sub> (dBm)	I <sub>VDD</sub> (mA)	P <sub>out</sub> (dBm)	I <sub>VDD</sub> (mA)	P <sub>out</sub> (dBm)	I <sub>VDD</sub> (mA)
7	10.0	17.5	10.3	16.8	10.5	16.4
6	5.8	13.2	7.0	13.0	8.6	13.3
5	3.1	11.5	4.3	11.6	5.7	11.5
4	0.5	10.5	1.7	10.6	2.8	10.2
3	-1.9	9.9	-1.1	10.0	-0.1	9.3
2	-4.2	9.5	-3.8	9.5	-3.2	8.6
1	-6.7	9.1	-6.8	9.2	-6.5	8.2
0	-9.2	8.9	-9.8	9.0	-9.7	7.9
PA off		5.4		6.1		5.4

Table 11. Output Power and Current Consumption vs. Power Level Setting (PA2..PA1) for 315, 434 and 915MHz.

### Frequency Synthesizer

Adr	Data							
	D7	D6	D5	D4	D3	D2	D1	D0
A6..A0	D7	D6	D5	D4	D3	D2	D1	D0
0000001	-	-	A0_5=0	A0_4=0	A0_3=1	A0_2=1	A0_1=1	A0_0=0
0000010	-	-	-	-	N0_11=0	N0_10=0	N0_9=0	N0_8=0
0000011	N0_7=0	N0_6=1	N0_5=1	N0_4=1	N0_3=0	N0_2=0	N0_1=1	N0_0=1
0000100	-	-	-	-	M0_11=0	M0_10=0	M0_9=0	M0_8=0
0000101	M0_7=0	M0_6=0	M0_5=1	M0_4=0	M0_3=0	M0_2=0	M0_1=0	M0_0=1
0000110	-	-	A1_5=0	A1_4=1	A1_3=1	A1_2=1	A1_1=1	A1_0=1
0000111	-	-	-	-	N1_11=0	N1_10=0	N1_9=0	N1_8=0
0001000	N1_7=0	N1_6=1	N1_5=1	N1_4=0	N1_3=1	N1_2=1	N1_1=1	N1_0=1
0001001	-	-	-	-	M1_11=0	M1_10=0	M1_9=0	M1_8=0
0001010	M1_7=0	M1_6=0	M1_5=1	M1_4=0	M1_3=0	M1_2=0	M1_1=0	M1_0=0
0010000	'0'	Prescaler_Sel=0	FSKClk_K5=1	FSKClk_K4=1	FSKClk_K3=0	FSKClk_K2=1	FSKClk_K1=0	FSKClk_K0=0

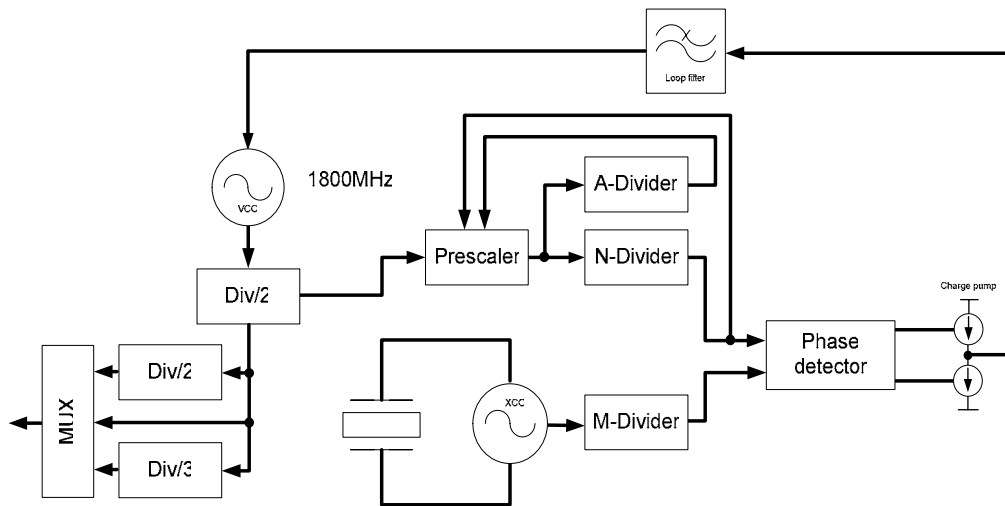

Figure 8. PLL Block Diagram.

The frequency synthesizer consists of a voltage-controlled oscillator (VCO), crystal oscillator, prescaler, programmable frequency dividers, phase-detector and charge pumps. Two different types of prescalers are integrated, a pulse swallow and a phase select prescaler. The recommended prescaler is the phase select prescaler (Prescaler\_Sel=0, which is default). There is both a configurable on-chip loop filter and an external loop filter. The lengths of the N and M and A registers are 12, 12 and 6 bits respectively. The M, N and A values can be calculated from the formula:

Phase select prescaler (Prescaler\_Sel=0):

$$f_{RF} = \frac{f_{XCO}}{M \cdot k} (31N + A)$$

Pulse swallow prescaler (Prescaler\_Sel=1):

$$f_{RF} = \frac{f_{XCO}}{M \cdot k} (32N + 2A),$$

where:

$f_{XCO}$ : Crystal oscillator frequency

$f_{RF}$ : RF frequency

$0 < A \leq N$

k: 6: RF frequency 290-325 MHz,  
Freq\_Band[1:0]=0

4: RF frequency 430-490 MHz,  
Freq\_Band[1:0]=1

2: RF frequency 860-980 MHz,  
Freq\_Band[1:0]=2-3

There are two sets of each of the divide factors (i.e. A0 and A1). If modulation by using the dividers is selected (Modulation1=1, Modulation0=0), the two sets should be programmed to give two RF frequencies, separated by two times the specified single sided frequency deviation. For all other modulation methods, the 0-set will be used. The value of A is constrained to be less or equal to N,  $0 \leq A \leq N$ .

### Crystal Oscillator (XCO)

Adr	Data							
A6..A0	D7	D6	D5	D4	D3	D2	D1	D0
0010101	ClkOut_1=0	ClkOut_0=0	XCO_Fast=1	XCOtune4=1	XCOtune3=0	XCOtune2=0	XCOtune1=0	XCOtune0=0

The crystal oscillator is a very critical block. As the crystal oscillator is a reference for the RF output frequency, very good phase and frequency stability is required. When selecting crystal it should be paid special attention to the total frequency tolerance and load capacitance as these will directly influence on the carrier frequency.

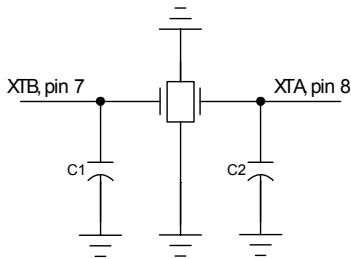

Figure 9. Crystal Oscillator Circuit.

The crystal should be connected between pins XTA and XTB (pin 7 and 8). MICRF405 has an internal crystal capacitor bank used for crystal tolerance tuning during production. These internal capacitors can be enabled using the XCOtune[4:0] bits. If XCOtune[4:0]=0 then no internal capacitors are connected to the crystal pins, while 18pF are connected to each pin if XCOtune[4:0]=31. The unit capacitance is about 0.6pF. The internal XCOtune feature is optimized for a crystal with a load capacitance of 9pF and will give the expected oscillation frequency when no external capacitors are connected and XCOtune[4:0]=16. If a crystal requires higher load capacitance, additional

capacitors must be added off-chip (C1 and C2 in Figure 9).

If XCOtune[4:0]=0, the loading capacitors can be calculated by the following formula;

$$C_L = \frac{1}{\frac{1}{C_1} + \frac{1}{C_2}} + C_{parasitic}$$

The parasitic capacitance is the pin input capacitance and PCB stray capacitance. Typically the total parasitic capacitance is around 6pF. For instance, for a 9pF load crystal the recommended values of the external load capacitors are 5.6pF.

The start-up time of a crystal oscillator is typically around a millisecond. Therefore, to save current consumption, the XCO is turned on before any other circuit block. During start-up the XCO amplitude will eventually reach a sufficient level to trigger the M-counter. After counting 2 M-counter output pulses the rest of the circuit will be turned on. The current consumption during the prestart period is typically 205µA. If the XCO\_Fast bit is set, then XCO will start up faster, typically in about 300µs. This comes at the expense of a higher current consumption of typically 2mA during the period from start up until the first output pulse of the M-divider.

If an external reference shall be used instead of a crystal, the signal shall be applied to pin 7, XTB. Due to internal biasing, AC coupling is recommended for use between the external reference and the XTB-pin.

## VCO

Adr	Data							
A6..A0	D7	D6	D5	D4	D3	D2	D1	D0
0001011	LowBatt_en=1	Freq_Band1=0	Freq_Band0=1	VCO_freq2=0	VCO_freq1=1	VCO_freq0=1	Modulation1=1	Modulation0=0
0010110	INT_LF_TEST=0	VCO_IB2=0	VCO_IB1=0	VCO_IB0=0	VCO_by=0	OUTS2=0	OUTS1=0	OUTS0=0
0011000	VCO_freq_O2	VCO_freq_O1	VCO_freq_O0			VC_HI	VC_LO	LOW_BATT

The VCO has no external components. It oscillates at 1.8 GHz and is divided by 2, 4 and 6 in the 900 MHz, 450 MHz or 315MHz band respectively. This divide ratio is controlled by the Freq\_Band[1:0] bits, as shown in Table 12.

FreqBand1	FreqBand0	Comments
0	0	RF frequency 290-325 MHz
0	1	RF frequency 430-490 MHz
1	X	RF frequency 860-980 MHz

**Table 12. Frequency Band.**

The VCO\_IB setting is automatically set when VCO\_IB[2:0]=0. If VCO\_IB[2:0] are programmed <> 0, it will overrule the automatic setting. Default and recommended for automatic settings, is VCO\_IB[2:0]=0 for all frequencies.

The bias bits will optimize the phase noise, and the frequency bits will control a capacitor bank in the VCO. The tuning range, the RF frequency versus varactor voltage, is dependent upon the VCO frequency setting, and is shown in Figure 10. When the tuning voltage is in the range from 1.2 to 1.6V, then the VCO gain is at its maximum, approximately 60-80 MHz/V. It is recommended that the varactor voltage is kept within this range. Table 15 shows the recommended settings of VCO\_freq and FreqBand for various frequencies.

To ensure correct settings over variations, a circuit monitoring the varactor voltage on start up is added. When the PLL has locked, or after a timeout has occurred if it doesn't lock, this circuit will control the varactor voltage. This will be performed if either the VCO\_Fr\_Chk or VCO\_Fr\_Auto bit is set. VCO\_Fr\_Chk set will set the interrupts VC\_HI, in case of a too high VCO\_freq setting creating a too high varactor voltage, and VC\_LO, in case of a too

low VCO\_freq setting creating a too low varactor voltage. If the VCO\_Fr\_Auto bit is set, then the transmitter will, if the varactor voltage is out of range, change the programmed VCO\_freq setting until the voltage is within the range. A new setting will remain active as long as power is on, VCO\_Fr\_Auto is set and the programmed VCO\_freq[2:0] bits are not altered. The tuned VCO\_freq setting of the automatic tune circuit can be read out in the interrupt register, VCO\_Freq\_O[2:0]. If both VCO\_Fr\_Chk and VCO\_Fr\_Auto are set, each step is done by the automatic tuning circuit that will be flagged with a VC\_LO or VC\_HI interrupt. The limits of varactor voltage used by this control circuit are between 350mV and 350mV below AVDD. The check is performed when entering TX mode. If PA\_LDc\_en=1, the control will also be executed for each programming creating an internal load pulse (load\_en=1) while staying in TX mode. This means that when changing frequency, the MICRF405 will check that the VCO\_Freq[2:0] settings are correct for the new frequency. Refer to Table 13 and Table 14 for further details.

The MICRF405 must be programmed with the recommended settings for FreqBand and VCOfreq, as given in Table 15, even if the VCO\_Fr\_Chk and VCO\_Fr\_Auto are enabled. This is needed to give the VCO the correct starting values.

The VCO can be bypassed by applying a differential local oscillator (LO) signal to the device on pin CPOUT and VARIN. A resistor of 18kΩ to ground and a series capacitor of 47pF are needed on both pins for proper biasing. The bit VCO\_by must be set to 1.

VCO_Fr_Chk	Comments
0	VCO control voltage is not controlled
1	VCO control voltage is measured; if it is below 0.35V the VC_LO interrupt flag is set, if it is higher than AVDD-0.35V the VC_HI flag is set

**Table 13. VCO Control Voltage Out of Range Detection.**

VCO_Fr_Auto	Comments
0	No calibration is done.
1	If VCO control voltage is below 0.35V or above AVDD-0.35V, the VCO frequency settings are altered until the control voltage is within the window. No VC_LO or VC_HI interrupt flag is set. The new settings can be read out; bits VCO_Freq_O[2:0] in interrupt register. If PLL for some reason cannot obtain lock (i.e. if frequency is set wrongly), an interrupt will be given even if VCO_Fr_Chk = 0.

**Table 14. Automatic VCO Range Calibration.**

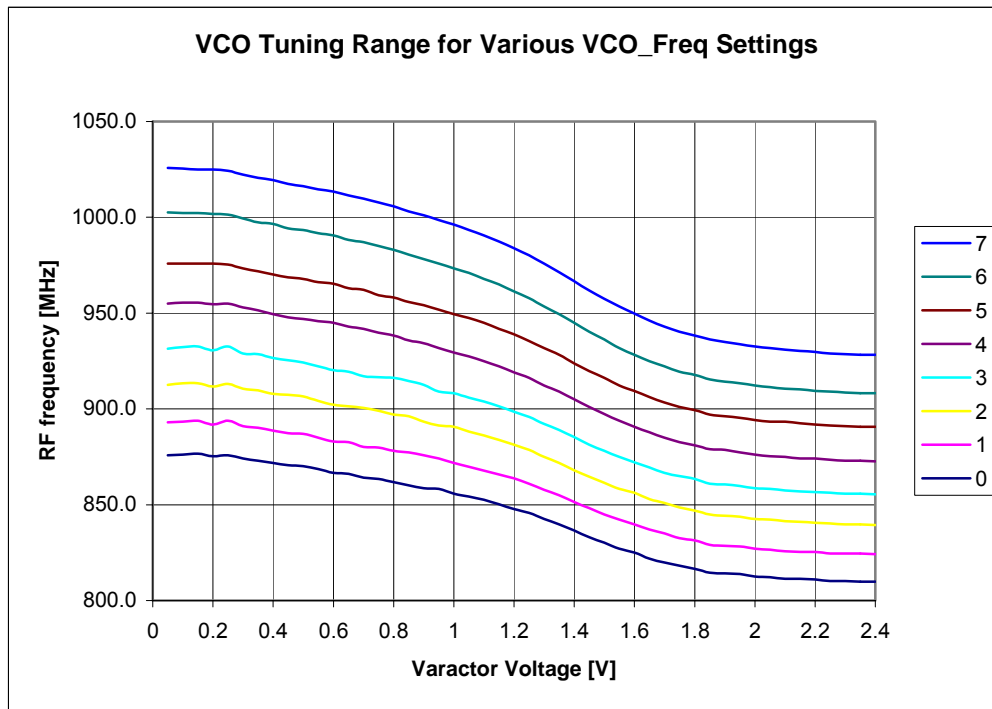

**Figure 10. RF Frequency vs. Varactor Voltage and VCO Frequency Bit.**

VCO_freq	FreqBand=0 315MHz		FreqBand=1 433MHz		FreqBand=2 or 3 868, 915MHz	
1	287	290	430	435	860	870
2	290	293	435	440	870	880
3	293	300	440	450	880	900
4	300	307	450	460	900	920
5	307	313	460	470	920	940
6	313	320	470	480	940	960
7	320	326	480	490	960	980

**Table 15. Freq Ranges vs. VCO\_freq and FreqBand.**

### Charge Pump and PLL Filter

Adr	Data							
	D7	D6	D5	D4	D3	D2	D1	D0
0010011	INT_LF_EN=1	CP_CUR1=0	CP_CUR0=1	LF_RES1_4=0	LF_RES1_3=1	LF_RES1_2=0	LF_RES1_1=0	LF_RES1_0=1
0010100	LF_High_PM=1	LF_CAP1=1	LF_CAP0=1	LF_RES3_4=0	LF_RES3_3=0	LF_RES3_2=1	LF_RES3_1=0	LF_RES3_0=1
0010110	INT_LF_TEST=0	VCO_IB2=0	VCO_IB1=0	VCO_IB0=0	VCO_by=0	OUTS2=0	OUTS1=0	OUTS0=0

There are two charge pumps, one for the external loop filter, and one for the internal filter. Both pumps have four different output current steps controlled by the CP\_CUR[1:0] bits (refer to Table 16). The internal loop filter is a dual path type, which needs two charge pump currents. The different steps allow different bandwidths for the internal filter and give greater flexibility when choosing components for the external filter.

An external PLL loop filter is recommended when using FSK modulation that is applied with dividers and closed loop modulation using the modulator. For Open Loop modulation a combination of external and internal loop filter is recommended. In all modes of ASK/OOK modulation, it is only possible to use internal PLL loop filter due to the high bandwidth requirements.

Table 15 below shows three different loop filters, the three first are for closed loop modulation and the last one is for open loop modulation. The component values are calculated with RF frequency = 915MHz, VCO gain = 67MHz/V and charge pump current = 100uA. Other settings are also shown in Table 15. The varactor pin capacitance of 10-12pF does not influence on the component values for the two filters with lowest bandwidth. For the 12kHz bandwidth filter, a third order loop filter is calculated. The third pole is set by R2 and C3. Here C3 is chosen to be 12pF, the same as the varactor input pin capacitance. C3 can therefore be skipped.

A schematic for a third order loop filter is shown in Figure 11a. For a second order filter, C3 is not connected and R2 is 0 Ω. When designing a third order loop filter, the internal capacitance on the VARIN pin of approximately 10-12pF must be taken into consideration. Figure 11b shows the loop filter configuration for the open loop VCO modulation case.

The on-chip dual path filter is shown in Figure 11c. The dual path loop filter has capacitance configurable in four steps, by the LF\_CAP[1:0] bits. The ratio between C1 and C2 in Figure 11 c) sets the phase margin of the filter. If LF\_High\_PM bit is not set the phase margin is 56°, if it is set the phase margin is 69°. The R1 and R3 resistor value is set separately in 32 steps by the LF\_RES1[4:0] and LF\_RES3[4:0] bits.

The on-chip dual path filter can be used when the modulation type is set to Open-Loop VCO or ASK. Table 18 gives the recommended settings for the internal component values for various bitrates and phase detector frequencies. The settings are calculated to give optimal phase margin for the given phase-frequency-detector frequency and loop filter bandwidth. (More values of C and R can be found in Table 52 and Table 52 on page 40 and 41).

CP_CUR1	CP_CUR0	External Charge Pump Current	Internal Charge Pump Current
0	0	12.5µA	1.25/12.5µA
0	1	25µA	3.125/31.25µA
1	0	50µA	6.25/62.5µA
1	1	100µA	12.5/125µA

Table 16. Charge Pump.

Mod. Type	Freq [MHz]	Baud Rate [kbaud/sec]	Coding	PLL BW [kHz]	Phase margin [°]	Phase detector Freq. [kHz]	C1 [nF]	C2 [nF]	R1 [kΩ]	R2 [kΩ]	C3 [pF]
VCO	All	> 30	Manchester	0.8	56	100	10	100	6.2	-	-
VCO	All	> 100	Manchester	3.0	56	100	0.68	68	27	-	-
Divider	315	< 20	DC-free	17	60	500	0.068	6.8	30	75	12
Divider	433	< 20	DC-free	18	60	500	0.068	6.8	30	75	12
Divider	868	< 15	DC-free	20	51	700	0.082	4.7	27	75	18
Divider	915	< 20	DC-free	21	60	500	0.047	4.7	36	91	5.6
Open loop	All	< 200	DC-free	26	56	500	0.047	0.47	43	NC	33000

Table 17. External Loop Filter Values.

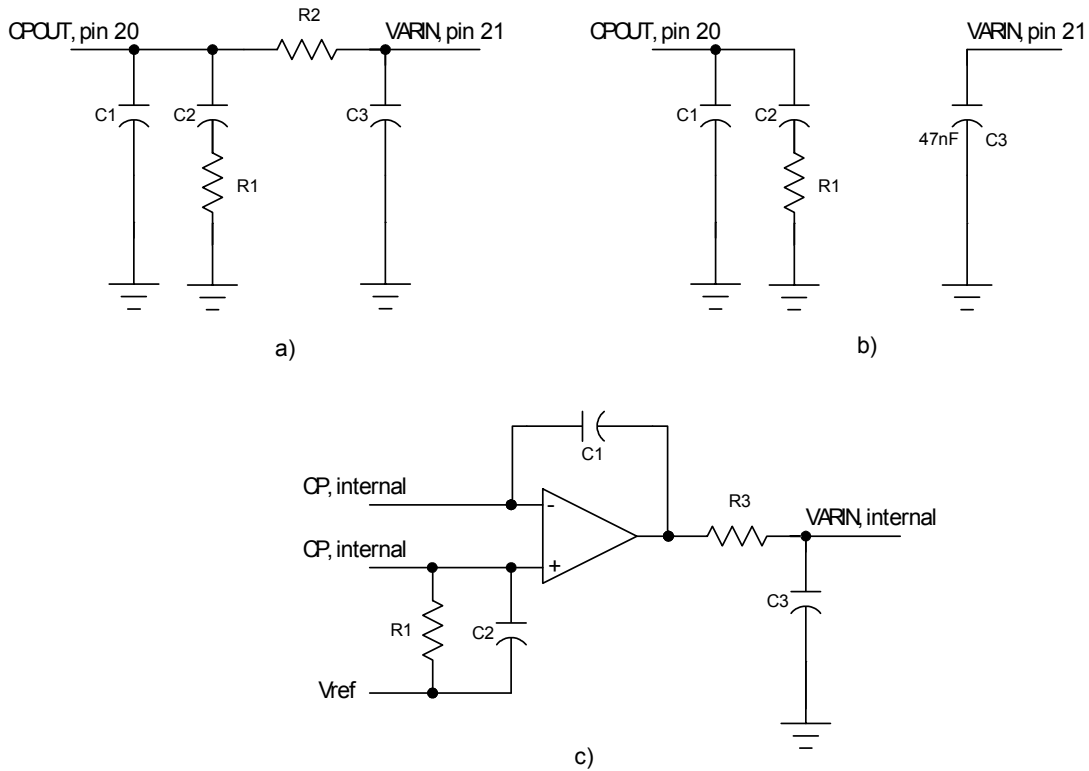

Figure 11. Loop filter for: a) Closed Loop Modulation, b) Open Loop Modulation and c) Internal Dual Path Filter.

Modulation type	Fphd [kHz]	BW [kHz]	CP [uA]	CP_CUR	C1 [pF]	C2 [pF]	LF_CAP	R1 [kΩ]	LF_RES1	R3 [kΩ]	LF_RES3
Open loop VCO	500	22.5	3.125/31.25	1	32.4	10.8	3	96	7	57	8
Open loop VCO	1000	45	6.25/62.5	2	32.4	10.8	3	48	2	28	3
ASK ≤4.8kbps	1000	32	3.125/31.25	1	32.4	10.8	3	68	4	40	5
ASK ≤9.6kbps	2000	64	6.25/62.5	2	32.4	10.8	3	34	1	20	2
ASK >9.6kbps	2000	220	12.5/125	3	5.4	1.8	0	76	5	5	0

**Table 18. Internal Dual Path Filter Settings.**

The design of the PLL filter will strongly affect the performance of the frequency synthesizer. Input parameters, when designing the loop filter for the MICRF405, are mainly the modulation method and the bit rate. Internal loop filter, which have relative

high bandwidths, is recommended for ASK. The external filter must be used when the bandwidth must be low. These choices will also affect the switching time and phase noise.

## Modulation

Adr	Data							
A6..A0	D7	D6	D5	D4	D3	D2	D1	D0
0001011	LowBatt_en=1	Freq_Band1=0	Freq_Band0=1	VCO_freq2=0	VCO_freq1=1	VCO_freq0=1	Modulation1=1	Modulation0=0
0001110	Mod_I4=0	Mod_I3=1	Mod_I2=0	Mod_I1=0	Mod_I0=1	Mod_A2=0	Mod_A1=1	Mod_A0=1
0001111	VCO_Fr_Chk=0	VCO_Fr_Auto=0	FSKKn2=1	FSKKn1=0	FSKKn0=0	Mod_F2=1	Mod_F1=0	Mod_F0=0
0010000	MOD_TEST1=0	Prescaler_Sel=0	FSKClk_K5=1	FSKClk_K4=1	FSKClk_K3=0	FSKClk_K2=1	FSKClk_K1=0	FSKClk_K0=0
0010001	ASK_PN_en=0	ASK_EN=0	ASKshape2=1	ASKshape1=1	ASKshape0=1	ASK2=1	ASK1=1	ASK0=1
0010010	ASKn1=1	ASKn0=0	ASKClk_K5=1	ASKClk_K4=1	ASKClk_K3=0	ASKClk_K2=1	ASKClk_K1=0	ASKClk_K0=0

The frequency modulation can be done in three different ways with the MICRF405, either by closed-, open loop VCO modulation or by modulation with the internal dividers. Amplitude modulation can also be done in two different ways, either ASK/OOK or Spread Spectrum ASK™. All these different types of modulation is selected by Modulation1-0 and ASK\_en (See chapter bit description for details).

**Closed loop VCO modulation** (Modulation[1:0]=0), the modulation is applied directly to the VCO. The PLL will see the modulation as a frequency error and try to tune the VCO back to carrier. The PLL bandwidth therefore, needs to be sufficiently low enough not to cancel the modulation (at least 20 times lower than the slowest variation of the modulation). Also, the modulation needs to be DC-free, usually by encoding the data by a DC-free code such as Manchester or 3b4b. In most cases, an external PLL loop filter must be used to fulfill the demand for low bandwidth. Please see the Modulator section for details on deviation and shaping.

**Open Loop VCO Modulation** (Modulation[1:0]=1), modulation is applied directly to the VCO. The VCO is now left free-running. The varactor voltage will now be stored on a large external capacitor connected to the VARIN pin and the PLL is disabled during the modulation. With the PLL disabled, the modulation will not be canceled and the modulated data signal may include DC-components. The switching between PLL active and disabled is done automatically by checking the DATAIN pin. If it is tri-stated the PLL is active, and if it is either high or low or transitioning between high or low the PLL is then disabled and the data on the DATAIN pin is transmitted. When data is transferred through the SPI the PLL is disabled during the transmission of a packet, while enabled else. In this mode, the PLL bandwidth can be fairly high as it is disabled during transmission. However, due to the large external capacitor, C3 in Figure 11b), the bandwidth is limited due to the pole created by this capacitor. Both internal with 56° phase margin and external filters

are suitable. A high quality capacitor of 10-47nF (COG type) should be connected on pin VARIN-to-ground to ensure minimum frequency drift due to leakage and frequency drift caused by the capacitor dielectric relaxation phenomenon (25kHz offset after 50ms). For deviation and shaping, please see the Modulator section. The frequency drift (Hz/ms) over temperature due to leakage is shown in Figure 12 with a 33nF COG external capacitor.

Figure 13 shows the frequency drift in open loop VCO modulation due to capacitor dielectric relaxation. The drift is around 40kHz during a time period of 50ms. Of the 40kHz drift, 5-10kHz is due to an initial offset caused by the modulator itself.

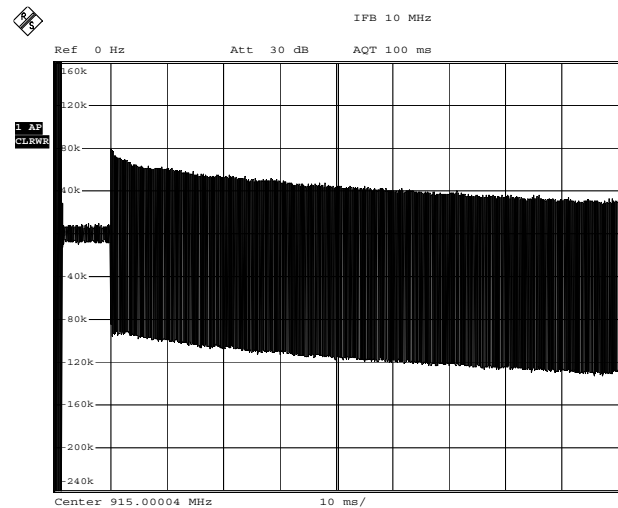

Date: 11.JAN.2006 10:10:03

**Figure 12. Frequency Drift Due to Capacitor Dielectric Relaxation at 915MHz.**

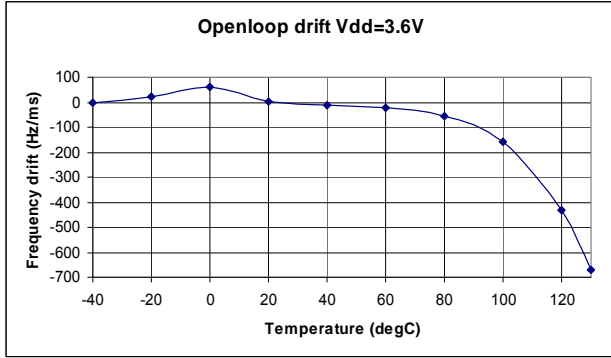

Figure 13. Carrier Drift in Open-Loop Modulation.

**Divider Modulation** Modulation[1:0]=2, modulation by switching between two sets of dividers, A0/N0/M0 and A1/N1/M1, is selected. In this case, the PLL needs to settle at the new frequency for each bit-shift. Therefore, the PLL bandwidth needs to be sufficiently high enough to follow the modulation. The PLL bandwidth/bit rate ratio controls the filtering of the modulation. A large ratio gives little filtering and a square shape to the data; while a small ratio gives hard filtering of the data. To avoid large overshoots, a large phase margin is desired, about 70 degrees will give about 10% overshoot. The tradeoff is less rejection of the phase detector frequency.

**ASK Modulation** is selected when ASK\_en=1 and Modulation[2:0]=3. The ASK modulation depth is controlled by the ASK[2:0] bits, and is equal to

{PA[2:0]-ASK[2:0]}\*3dB. If PA[2:0]<=ASK[2:0], the ASK modulation will be On Off Keying (OOK). For example, PA[2:0]=7 and ASK[2:0]=7 is OOK, but if ASK[2:0]=4, the modulation depth is -9dB (output power for “1” is 10dBm and “0” is 1dBm). The modulation depth is a tradeoff between occupied bandwidth and sensitivity in the receiver. When increasing the modulation depth, the pulling effect of the VCO will also increase and can be seen as FM components in the transmitted signal. To reject the pulling of the VCO, shaping can be applied to the ASK signal. The ASKshape[2:0] bits control the shaping, where ASKshape[2:0] = 7 gives the most shaping. The shaping is user selectable but a table of recommended values is shown in Table 19.

ASK bitrate (kbps)	Recommended ASKshape
< 4.8	7
< 9.6	6
< 19.2	4
< 38.4	2
< 50	0

Table 19. Recommended ASK Shaping.

A high PLL bandwidth will also help to avoid pulling of the VCO. The internal third order loop filter should be selected.

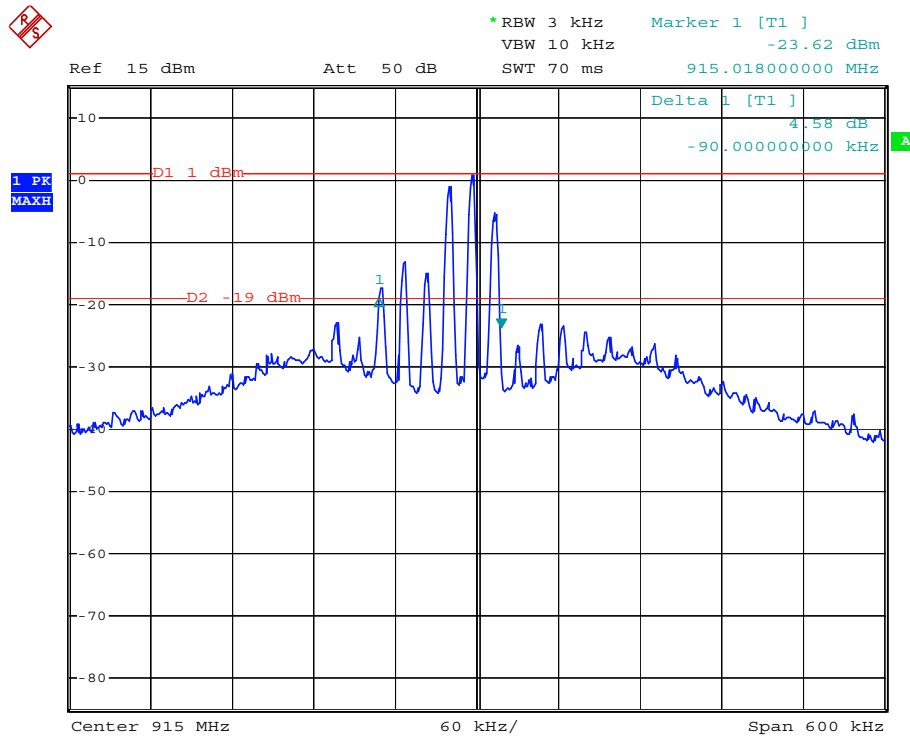

Date: 27.MAR.2006 17:23:27

**Figure 14. 33kbps, PA=6, ASK=7, ASKshape=2 (Fphd=2MHz, 209kHz internal loop filter).**

**Spread Spectrum ASK™** is a combination of traditional ASK combined with FSK dithering. This modulation type goes under FCC part 15.247 digital modulation allowing higher output power without FHSS. The FSK dithering frequency, applied to the ASK signal, is greater than the ASK data rate and therefore, a traditional ASK/OOK receiver with

500kHz noise bandwidth can be used. FSK is applied using divider modulation Modulation[1:0]=2, due to the high loop filter bandwidth requirement of the ASK modulation. The ASK\_PN\_en signal controls whether the dithering is a “010101”-pattern, ASK\_PN\_en=0, or a “111101011001000”-pattern, ASK\_PN\_en=1.

**Bit Rate Settings**

The bit rate is set separately for ASK and FSK modulation to support ASK modulation with FSK spreading. The FSK bit rate is set with the two parameters *FSKClk\_K* and *FSKn*. The relationship is

$$BR = \frac{f_{XTAL}}{FSKClk\_K \cdot 2^{3+FSKn}} \quad (1)$$

where:

BR: Bit rate.

fXTAL: Crystal oscillator frequency.

FSKClk\_K: Integer in the range [1..63] (6 bit).

FSKn: Integer in the range [0..5] (3 bit).

A procedure to find the settings for the desired bit rate is described below:

1. Set FSKn to 0.
2. Calculate FSKClk\_K by using this formula:

$$FSKClk\_K = \frac{f_{XTAL}}{BR \cdot 2^{3+FSKn}}$$

3. If FSKClk\_K is too high, increment FSKn by one, and then jump to 2.

In some cases, several combinations of FSKClk\_K and FSKn will give the bit rate. If VCO modulation is selected, Modulation[1:0] < 2, then the lower FSKn

the better shaping of the signal. However in some cases, low FSKn causes the modulator to saturate (Please see the section Modulator for details). When Manchester encoding is enabled, Manchester\_en=1, FSKn needs to bigger than zero for the modulator to operate properly.

When sending ASK with FSK spreading, FSKClk\_K and FSKn set the speed of the FSK spreading.

The bit rate of the ASK is set similar with the two parameters ASKClk\_K and ASKn. The relationship is now:

$$BR = \frac{f_{XTAL}}{ASKClk\_K \cdot 2^{5+ASKn}} \quad (2)$$

where the new parameters are:

ASKClk\_K: Integer in the range [1..63] (6 bits).

ASKn: Integer in the range [0..3] (2 bits).

A procedure for finding a bit rate will be equal to FSK, but with this formula:

$$ASKClk\_K = \frac{f_{XTAL}}{BR \cdot 2^{5+ASKn}}$$

Due to the high flexibility of the modulator, a brief explanation of how it works will ease the use of it. Figure 15 shows a block diagram of the components of the modulator.

**Modulator**

Adr	Data							
	D7	D6	D5	D4	D3	D2	D1	D0
0001110	Mod_I4=0	Mod_I3=1	Mod_I2=0	Mod_I1=0	Mod_I0=1	Mod_A2=0	Mod_A1=1	Mod_A0=1
0001111	VCO_Fr_Chk=0	VCO_Fr_Auto=0	FSKn2=1	FSKn1=0	FSKn0=0	Mod_F2=1	Mod_F1=0	Mod_F0=0
0010000	MOD_TEST1=0	Prescaler_Sel=0	FSKClk_K5=1	FSKClk_K4=1	FSKClk_K3=0	FSKClk_K2=1	FSKClk_K1=0	FSKClk_K0=0

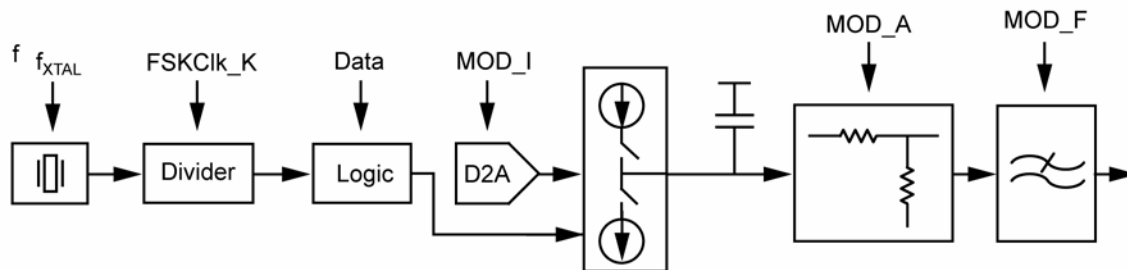

Figure 15. Modulator Block Diagram.

The two first blocks are generating a clock for the modulator. This clock is, together with the user data, used to control a charge pump. The charge pump current is controlled by a DAC. Each time the input data changes state, a charge is then injected into the capacitor to generate a modulation signal. The charge magnitude is controlled by the charging current and by charging time (inversely proportional with modulator clock). To be able to achieve small deviations, it is possible to attenuate the modulation signal. Finally, the signal is filtered to narrow transmitter output spectrum.

The procedure is first to determine the settings concerning the data bit rate, then, these values will be used in the calculation of the frequency deviation. Finally, the user must see if the desired values cause the modulator to saturate.

**Deviation Setting**

Deviation controlled by user parameters FSKClk\_K, MOD\_I, and MOD\_A, together with physical parameters fXTAL and KVCO. All user parameters can be set in software, and fXTAL (crystal oscillator frequency) is set when designing in the radio chip. KVCO (VCO gain) is a parameter of the radio chip, and is not controllable by the user.

The crystal oscillator frequency, fXTAL, is divided by FSKClk\_K to generate the modulator clock. Since this modulator clock is controlling the rise and fall times for the modulator, the frequency deviation is inversely proportional to this clock. The relationship is shown in equation (3):

$$f_{DEV} \propto \frac{FSKClk\_K}{f_{XTAL}} \tag{3}$$

It is assumed that FSKClk\_K will be constant for most applications to keep bit-rate and shaping constant, although this is not a requirement.

The primary two controls of frequency deviation are MOD\_I and MOD\_A. Of these two, MOD\_I is the parameter that controls the signal generation, while MOD\_A controls attenuation of this signal. The reason for using an attenuator is to be able to generate small deviations at high values of FSKClk\_K. The relationship is shown in equation (4).

$$f_{DEV} \propto \frac{MOD\_I}{2^{MOD\_A}} \tag{4}$$

Finally, the VCO gain is given by equation (5).

$$K_{VCO} = \frac{Const_1 + (Const_2 \cdot f_C \cdot (3 - FreqBand))}{3 - FreqBand} \tag{5}$$

where:

$$Const_1 = 30.6324 \times 10^9$$

Const2 54.7

fC: Carrier frequency of the radio.

FreqBand: Frequency band.

0: 315MHz,

1: 433MHz and

2: 900MHz.

In equation (5), it is evident that the VCO gain is dependent of carrier frequency. MOD\_I is probably the best parameter to alter if counteracting this effect if necessary.

Combining equations (3), (4), and (5) gives us an expression for the frequency deviation:

$$f_{DEV} = \frac{FSKClk\_K}{f_{XTAL}} \cdot \frac{MOD\_I}{2^{MOD\_A}} \cdot \frac{Const_1 + (Const_2 \cdot f_C \cdot (3 - FreqBand))}{3 - FreqBand} \tag{6}$$

Observe that equation (6) gives single-sided-deviation. Peak-to-peak deviation is twice this value.

**Shaping**

The modulation waveform will be shaped due to the charging and discharging of a capacitor. The waveform looks like a Gaussian filtered signal with a Bandwidth-Period-product, BT, given by:

$$BT = 2^{FSKn} \tag{7}$$

where:

BT: Shaping factor.

It is evident from this that a low FSKn gives a low shaping factor, and is thus preferred if it is possible to choose FSKn freely.

In addition to this, it is possible to smooth the modulator output in a programmable low-pass filter. This filter is controlled by the parameter MOD\_F. The parameter should be set according to equation (8).

$$MOD\_F \leq \frac{150 \times 10^3}{BR} \tag{8}$$

**Modulator Saturation**

The modulator output voltage is generated by a capacitor that is being charged. This means that there is a risk of saturating the modulator if the charge received by the capacitor is too large. Use equation (9) to determine the maximum value of MOD\_I that can be used.

$$MOD\_I \leq \left( \frac{f_{XTAL}}{FSKClk\_K} \cdot 28 \times 10^{-6} \right) + 1 \tag{9}$$

If it turns out that the MOD\_I-range is too small for your requirements, try increasing FSKn and decreasing FSKClk\_K accordingly.

## Lock Detect

Adr	Data							
	D7	D6	D5	D4	D3	D2	D1	D0
0001100	LowBatt_level=0	LDO_by=0	LDO_en1=1	LDO_en0=1	MOD_LDc_en=0	PA_FEc_en=0	PA_LDc_en=0	LD_en=1
0001111	VCO_Fr_Chk=0	VCO_Fr_Auto=0	FSKn2=1	FSKn1=0	FSKn0=0	Mod_F2=1	Mod_F1=0	Mod_F0=0

The lock detector can be enabled by setting LD\_en=1. When pin LD is high, it indicates that the PLL is in lock. Care must be taken when monitoring the LD during data transmission using the closed loop modulation. Due to the fact that the PLL tries to cancel the modulation signal, there will be some PLL activity during the transmission time, especially when the PLL BW is too high relative to the bitrate. The LD may therefore, show that the PLL is not in lock.

When starting a transmit session, the LD signal is helpful in deciding when to turn on the PA. When going from power down or stand by mode to TX mode, or after a frequency change, the PLL needs some time to lock on to the frequency. During this time it is necessary to keep the PA off. This is done by setting PA[2:0]=0 and PA\_LDc\_en=0. When the LD signal goes high, it is safe to turn on the PA, by setting the PA[2:0] to the desired output level. Depending on the output power, and the loop filter, the LD signal might drop during start up of the PA due to VCO pulling. When LD is high again it is time to start the modulation.

The lock detect signal is used internally in several functions; the VCO\_Fr\_Chk/Auto, the MOD\_LDc and the PA\_LDc. The VCO\_Fr\_Chk/Auto are described in detail under the VCO chapter.

PA\_LDc (PA Lock Detect Control) is used to automatically turn on the PA the moment the PLL has locked on to the frequency. This function is enabled when the PA\_LDc\_en bit is set. From power down or stand by, simply program the MICRF405 to TX with the wanted PA output setting. The MICRF405 will then automatically turn on the PA

once the PLL has locked. The PA will remain on until PA[2:0]=PA\_LDc\_en=0 or the transmitter leaves transmit mode (Mode[1:0]<>3). However, the PA is temporary turned off for every internal load pulse or if the DATAIN pin is tri-stated in open loop modulation (Modulation[1:0]=2). This means that if you want to change frequency, the PA will shut off during the settling of the new frequency, and then it is turned on once the PLL has locked on to the new frequency. It is necessary that LD\_en is set for the PA\_LDc function to work.

The correct time to start modulation will be internally decided when the MOD\_LDc (Modulation Lock Detect control) bit is set. This function is only working when data is transferred through the SPI (Bit\_IO\_en=0). The phase detector frequency (Fphd) has to be < 200kHz when MOD\_LDc is enabled. Program the MICRF405 in transmit at the proper output frequency and power strength. Then, write the frame length of the packet into the data buffer. The MICRF405 will now delay the modulation until the PLL has locked with PA turned on. For this function to work, both LD\_en and PA\_LDc\_en must be set. This function is especially useful when transmitting several packets without leaving the TX mode and the PA\_FEc\_en bit is set. After a packet is finished transmitted, the PA\_FEc function will turn the PA off until a new packet is to be sent. If the MOD\_LDc function is not enabled, the modulation and turning on the PA will then start simultaneously, there by creating distorted start of packet and interfering with the settling of the PLL due to PA turn on. With MOD\_LDc enabled the modulation will be delay until the PLL has locked with PA on.

### Low Dropout Regulator (LDO) and Low Battery Detector

Adr	Data							
	D7	D6	D5	D4	D3	D2	D1	D0
0001011	LowBatt_en=1	Freq_Band1=0	Freq_Band0=1	VCO_freq2=0	VCO_freq1=1	VCO_freq0=1	Modulation1=1	Modulation0=0
0001100	LowBatt_level=0	LDO_by=0	LDO_en1=1	LDO_en0=1	MOD_LDc_en=0	PA_FEc_en=0	PA_LDc_en=0	LD_en=1

The MICRF405 has three internal LDOs powering up different parts of the circuit, as can be seen in the Block Diagram. The output voltages of the LDOs are around 2.4V. The LDOs can be turned off (default setting is on) by setting the LDO\_en[1:0]=0.

When LDO\_en[1:0]=3, the power supply range is 2.2-3.6 volt. Power must be applied to pin 1 and 11. A capacitor is needed on each of the LDO output for stability (pin 3, 9 and 23). In sleep mode, all the LDOs are turned off. The interface and control blocks run on unregulated power, meaning that the register content will be kept and that the programming can also be done in this mode.

An option, where the LDOs are bypassed, is enabled by setting the LDO\_by bit, and when activated, the transmitter can operate at 2.2V-2.5V. Since the LDO drop is decreased, the output power is slightly higher. However, in this mode it is of vital importance that the input power is below 2.5V as the pass devices in the LDOs are fully on and not regulated. It is recommended that this option is used in combination with the low battery detector.

When LDO\_en[1:0]=0, the power supply range is 2.2-2.5 volt. Power must be applied to pin 1, 3, 9, 11 and 23. Capacitors are now only needed for normal

noise decoupling. Alternatively, connect power to pins 1 and 11 only, and set LDO[1:0]=3 and LDO\_by=0.

The LDOs are controlled with 2 bits, enabling the option of running the complete circuit on the RF LDO alone (LDO\_en[1:0]=1), or on the RF LDO and analog LDO (LDO\_en[1:0]=2). Doing so, regulated power on the RFVDD pin must be externally routed to the AVDD and DVDD pin in the first case and, and from the RFVDD to the DVDD pin in the second case. These modes will save one or two of the external capacitors used for stabilizing the LDOs, but might influence the phase noise and spurious performance. Recommended use is therefore, LDO\_en[1:0]=3 or 0.

The low battery detector circuit is turned on when the LowBatt\_en bit is set. It will monitor the voltage of the input power, pin 11, in standby and TX modes. If LDO\_by=0, it will set the LowBatt interrupt if the voltages falls below 2.1V for LowBatt\_level=1 and 2.0V for LowBatt\_level=0. If LDO\_by=1, it sets the interrupt when the voltages is below 1.9V/1.8V for LowBatt\_level=1/0.

### Bit Description

Adr	Data								
	A6..A0	D7	D6	D5	D4	D3	D2	D1	D0
0000000	Mode1=0	Mode0=1	PA2=1	PA1=1	PA0=1	ClkOut_en=1	Sync_en=1	Load_en=1	
0000001	-	-	A0_5=0	A0_4=0	A0_3=1	A0_2=1	A0_1=1	A0_0=0	
0000010	-	-	-	-	N0_11=0	N0_10=0	N0_9=0	N0_8=0	
0000011	N0_7=0	N0_6=1	N0_5=1	N0_4=1	N0_3=0	N0_2=0	N0_1=1	N0_0=1	
0000100	-	-	-	-	M0_11=0	M0_10=0	M0_9=0	M0_8=0	
0000101	M0_7=0	M0_6=0	M0_5=1	M0_4=0	M0_3=0	M0_2=0	M0_1=0	M0_0=1	
0000110	-	-	A1_5=0	A1_4=1	A1_3=1	A1_2=1	A1_1=1	A1_0=1	
0000111	-	-	-	-	N1_11=0	N1_10=0	N1_9=0	N1_8=0	
0001000	N1_7=0	N1_6=1	N1_5=1	N1_4=0	N1_3=1	N1_2=1	N1_1=1	N1_0=1	
0001001	-	-	-	-	M1_11=0	M1_10=0	M1_9=0	M1_8=0	
0001010	M1_7=0	M1_6=0	M1_5=1	M1_4=0	M1_3=0	M1_2=0	M1_1=0	M1_0=0	
0001011	LowBatt_en=1	Freq_Band1=0	Freq_Band0=1	VCO_freq2=0	VCO_freq1=1	VCO_freq0=1	Modulation1=1	Modulation0=0	
0001100	LowBatt_level=0	LDO_by=0	LDO_en1=1	LDO_en0=1	MOD_LDc_en=0	PA_FEc_en=0	PA_LDc_en=0	LD_en=1	
0001101	Bit_IO_en=1	Manchester_en=0	Sel_CRC1=1	Sel_CRC0=1	SyncID_Len1=0	SyncID_Len0=1	Pream_Len1=1	Pream_Len0=0	
0001110	Mod_I4=0	Mod_I3=1	Mod_I2=0	Mod_I1=0	Mod_I0=1	Mod_A2=0	Mod_A1=1	Mod_A0=1	
0001111	VCO_Fr_Chk=0	VCO_Fr_Auto=0	FSKk2=1	FSKk1=0	FSKk0=0	Mod_F2=1	Mod_F1=0	Mod_F0=0	
0010000	'0'	Prescaler_Sel=0	FSKClk_K5=1	FSKClk_K4=1	FSKClk_K3=0	FSKClk_K2=1	FSKClk_K1=0	FSKClk_K0=0	
0010001	ASK_PN_en=0	ASK_EN=0	ASKshape2=1	ASKshape1=1	ASKshape0=1	ASK2=1	ASK1=1	ASK0=1	
0010010	ASKn1=1	ASKn0=0	ASKClk_K5=1	ASKClk_K4=1	ASKClk_K3=0	ASKClk_K2=1	ASKClk_K1=0	ASKClk_K0=0	
0010011	INT_LF_EN=1	CP_CUR1=0	CP_CUR0=1	LF_RES1_4=0	LF_RES1_3=1	LF_RES1_2=0	LF_RES1_1=0	LF_RES1_0=1	
0010100	LF_High_PM=1	LF_CAP1=1	LF_CAP0=1	LF_RES3_4=0	LF_RES3_3=0	LF_RES3_2=1	LF_RES3_1=0	LF_RES3_0=1	
0010101	ClkOut_1=0	ClkOut_0=0	XCO_Fast=1	XCOtune4=1	XCOtune3=0	XCOtune2=0	XCOtune1=0	XCOtune0=0	
0010110	INT_LF_TEST=0	VCO_IB2=0	VCO_IB1=0	VCO_IB0=0	VCO_by=0	OUTS2=0	OUTS1=0	OUTS0=0	
0010111	PA_IB3=1	PA_IB2=0	PA_IB1=0	PA_IB0=1	PAB_IB3=1	PAB_IB2=0	PAB_IB1=0	PAB_IB0=1	
0011000	VCO_freq_O2	VCO_freq_O1	VCO_freq_O0			VC_HI	VC_LO	LOW_BATT	
0011001	SyncID3_7=1	SyncID3_6=1	SyncID3_5=1	SyncID3_4=0	SyncID3_3=0	SyncID3_2=1	SyncID3_1=0	SyncID3_0=1	
0011010	SyncID2_7=1	SyncID2_6=1	SyncID2_5=1	SyncID2_4=0	SyncID2_3=0	SyncID2_2=1	SyncID2_1=0	SyncID2_0=1	
0011011	SyncID1_7=1	SyncID1_6=1	SyncID1_5=1	SyncID1_4=0	SyncID1_3=0	SyncID1_2=1	SyncID1_1=0	SyncID1_0=1	
0011100	SyncID0_7=1	SyncID0_6=1	SyncID0_5=1	SyncID0_4=0	SyncID0_3=0	SyncID0_2=1	SyncID0_1=0	SyncID0_0=1	
0011101	DATA_7	DATA_6	DATA_5	DATA_4	DATA_3	DATA_2	DATA_1	DATA_0	

The 5 last bytes (0011001-0011101) are valid instantly, in other words, no load pulse (raising SEN) is needed to activate the changes.

Mode1	Mode0	State	Comments
0	0	Power down	Keeps Register configuration
0	1	Standby	Crystal Oscillator running
1	0		
1	1	Transmit mode	Transmit mode

Table 20. Main Mode.

PA2	PA1	PA0	State
0	0	0	21dB attenuation or PA off if PA_LDc_en=0
0	0	1	18dB attenuation
0	1	0	15dB attenuation
0	1	1	12dB attenuation
1	0	0	9dB attenuation
1	0	1	6dB attenuation
1	1	0	3dB attenuation
1	1	1	Max output

Table 21. Power Amplifier.

ClkOut_en	ClkOut_1	ClkOut_0	State	Comments
0	X	X	CLKOUT off	Output is 0 volt.
1	0	0	CLKOUT on	The XCO frequency is divided by 16.
1	0	1	CLKOUT on	The XCO frequency is divided by 8.
1	1	0	CLKOUT on	The XCO frequency is divided by 4.
1	1	1	CLKOUT on	The XCO frequency is divided by 2.

Table 22. Output Clock.

Bit_IO_en	Sync_en	State	Comments
0	X	DCLK pin on, RDY	Byte ready, RDY, signal from databyte
1	0	DCLK pin off	Transparent transmission of data
1	1	DCLK pin on, DATACLK	Bit-clock is generated by transmitter

Table 23. Synchronizer Mode

ASK_EN	Modulation1	Modulation0	State	Comments
0	0	0	Closed loop VCO-modulation	VCO is phase-locked
0	0	1	Open loop VCO-modulation	VCO is free-running
0	1	0	Modulation by A,M and N	Modulation inside PLL
0	1	1	Not used	
1	0	0	ASK modulation with spreading code applied to VCO. Not recommended.	VCO is phase-locked
1	0	1	ASK modulation with spreading code applied to VCO. Not recommended.	VCO is free-running
1	1	0	ASK modulation with spreading code applied to internal modulation by A, M and M	Modulation inside PLL
1	1	1	ASK modulation	VCO is phase-locked

Table 24. Modulation.

ASK2	ASK1	ASK0	State
0	0	0	3dB ASK depth
0	0	1	6dB ASK depth
0	1	0	9dB ASK depth
0	1	1	12dB ASK depth
1	0	0	15dB ASK depth
1	0	1	18dB ASK depth
1	1	0	21dB ASK depth
1	1	1	> 30dB ASK depth

**Table 25. ASK Modulation Depth When PA[2:0]=7.**

ASKshape	Comments
0..7	Programmable ASK filter. It can be programmed in eight steps. "0" is no shaping, "7" most shaping.

**Table 26. ASK Shaping/Filtering.**

XCOtune	Comments
0..31	Programmable XCO load capacitor

**Table 27. XCO Capacitor Setting.**

XCO_Fast	Comments
0	The XCO is running on a constant bias current.
1	When going from PD to TX mode, the XCO is running on a high current during start up.

**Table 28. XCO Fast Startup.**

Low_Batt_en	LowBatt_level	LDO_by	Comments
0	X	X	Low battery detect circuit off
1	0	0	Low battery detect circuit active. Interrupt is flagged if VDD falls below 2V.
1	1	0	Low battery detect circuit active. Interrupt is flagged if VDD falls below 2.1V.
1	0	1	Low battery detect circuit active. Interrupt is flagged if VDD falls below 1.8V.
1	1	1	Low battery detect circuit active. Interrupt is flagged if VDD falls below 1.9V.

**Table 29. Low Battery Detect.**

LDO_by	LDO_EN1	LDO_EN0	Comments
X	0	0	LDOs turned off, power applied to AVDD, DVDD, RFVDD, min/max is 2.0/2.5 V, and to VDD pin 11 and 1, min/max is 2.0/3.6V.
1	X	X	LDOs bypassed, power applied to the VDD pin1 and VDD pin11, min/max is 2.0/2.5 V
0	0	1	PA LDO turned on, power applied to VDD pin1 and 11, min/max is 2.0/3.6V, and to AVDD and DVDD, min/max is 2.0/2.5V
0	1	0	PA and AVDD LDO turned on, power applied to the VDD pin1 and 11, min/max is 2.0/3.6V, and to DVDD, min/max is 2.0/2.5V
0	1	1	PA, AVDD and DIG LDO turned on, power applied to the VDD pin1 and VDD pin 11, min/max is 2.0/3.6V

**Table 30. Low DropOut Voltage Regulator.**

PA_LDc_en	Comments
0	PA is only controlled by Mode1 and Mode and PA0-2, PA on in transmit mode (Mode[1:0]=3 and PA[2:0]>0)
1	In transmit mode, PA is turned on by Lock Detect (LD=1 -> PA on). PA is turned off by load pulse or when using openloop modulation and setting the DATAIN pin in tri-state. PA will be turned on again once LD goes high again. LD_en must be set to 1.

**Table 31. Lock Detect Controlled PA.**

MOD_LDc_en	Comments
0	Modulation starts once frame length is written into data byte.
1	Modulation starts once frame length is written into data byte and PA is turned on and LD is high.

**Table 32. Lock Detect Controlled Start of Modulation (only for BIT\_IO\_en=0).**

PA_FEc_en	Comments
0	PA is turned off by Mode1 and Mode0 or PA0-2 and PA_LDc_en=0
1	PA is turned off immediately after the frame is transmitted.

**Table 33. Frameend Controlled PA.**

LD_en	State	Comments
0	LD off	Output is 0 volt, or test signals specified by OUTS[2:0]
1	LD on	LD pin high indicate that the PLL is locked

**Table 34. Lock Detector.**

SyncID_Len1	SyncID_Len0	Comments
0	0	SyncID length is 1 byte. SyncID0 is sent
0	1	SyncID length is 2 bytes. SyncID0 and SyncID1 is sent
1	0	SyncID length is 3 bytes. SyncID0, SyncID1 and SyncID2 is sent
1	1	SyncID length is 4 bytes. SyncID0, SyncID1, SyncID2 and SyncID3 is sent.

**Table 35. SyncID Field Length.**

Pream_Len1	Pream_Len0	Comments
0	0	Preamble length is 1 byte.
0	1	Preamble length is 2 bytes.
1	0	Preamble length is 3 bytes.
1	1	Preamble length is 4 bytes.

Table 36. Preamble Field Length.

Sel_CRC1	Sel_CRC0	Comments
0	X	CRC disabled
1	0	CCITT-8 CRC enabled. Byte is sent after payload data. Polynomial function: $X^8+X^5+X^4+1$ . (Byte part of Frame Length)
1	1	ITU-16 CRC enabled. Bytes are sent after payload data. Polynomial function: $X^{16}+X^{12}+X^5+1$ . (Byte part of Frame Length)

Table 37. CRC Select.

Manchester_en	Comments
0	Manchester encoding disabled.
1	Manchester encoding enabled. Data will be encoded before transmitted. FSKn > 0 when using modulator.

Table 38. Manchester Encoding (only when BIT\_IO\_en=0).

VCO_freq2	VCO_freq1	VCO_freq0	Comments
0	0	0	Not used
0	0	1	
0	1	0	868 MHz, 433MHz
0	1	1	
1	0	0	915 MHz
1	0	1	
1	1	0	950MHz, 315MHz
1	1	1	

Table 39. VCO Frequency.

MOD_I	Comments
1..31	The deviation is linearly dependent of MOD_I

Table 40. Modulator Current Setting for Frequency Deviation.

MOD_A	Comments
0..4	Frequency deviation attenuator (or range selector). The attenuations are (values 0 through 4, respectively) $\frac{1}{1}$ , $\frac{1}{2}$ , $\frac{1}{4}$ , $\frac{1}{8}$ and $\frac{1}{16}$

Table 41. Modulator Attenuator Setting for Frequency Deviation.

MOD_F	Comments
0..3	Programmable smoothing filter after attenuator. This can be programmed in four steps, and will produce reasonable results for the highest bit rates.

**Table 42. Modulator Filter Setting.**

FSKn	Comments
0..5	The bit rate clock is set by dividing the crystal oscillator frequency by $FSKClk\_K \cdot 2^{(3+FSKn)}$ .

**Table 43. Bit Rate Setting.**

FSKClk_K	Comments
1..63	The crystal oscillator is divided by this number to produce modulator clock and it is divided further down by $2^{(3+FSKn)}$ to produce the bit rate clock.

**Table 44. Modulator and Bit Rate Clock Setting.**

ASKn	Comments
0..3	The ASK bitrate clock is set by dividing the crystal oscillator frequency by $ASKClk\_K \cdot 2^{(5+ASKn)}$

**Table 45. Bit Rate Setting.**

ASKClk_K	Comments
1..63	The crystal oscillator is divided by this number and is divided further down by $2^{(5+ASKn)}$ to produce the ASK bitrate clock.

**Table 46. Modulator and Bit Rate Clock Setting.**

ASK_PN_en	Comments
0	01010101...pattern is used in the FSK spreader during ASK.
1	111101011001000 repeated pattern is used in the FSK spreader during ASK.

**Table 47. ASK Spreading.**

VCO_IB2	VCO_IB1	VCO_IB0	Comments
1	1	1	Bias setting for VCO_Freq=0/1, 860 MHz
1	0	1	Bias setting for VCO_Freq=2/3, 868 MHz
0	1	1	Bias setting for VCO_Freq=4/5, 915 MHz
0	0	0	Bias setting for VCO_Freq=6/7, 950 MHz (**)

(\*\*): When VCO\_IB=000b, the bias current is set automatically by the two VCO\_freq bit.

**Table 48. VCO Bias Bit.**

VCO_by	State	Comment
0	VCO is active	When VCO is bypassed, a differential signal can be applied to the circuit using pin CPOUT and VARIN
1	VCO is bypassed	

**Table 49. VCO Bypass Bit.**

OutS2	OutS1	OutS0	The signals are available on the LD output
0	0	0	Gnd
0	0	1	N-div
0	1	0	M-div
0	1	1	ModOut
1	0	0	Bandgap
1	0	1	
1	1	0	DVDD
1	1	1	TXSYMBOL – output of packet handling engine

**Table 50. Test Signals. Only Available When LD\_en=0.**

PA_IB3	PA_IB2	State
0	0	PA uses bias current from PTAT bias source, external resistor (Pin 6)
0	1	PA uses bias current from CI bias source, external resistor (Pin 24)
1	0	PA uses bias current from internal bias source, PTAT
1	1	PA uses bias current from internal bias source, PTAT + CI
PA_IB1	PA_IB0	State
0	0	PA bias current setting, lowest bias current
0	1	PA bias current setting
1	0	PA bias current setting
1	1	PA bias current setting, highest bias current
PAB_IB3	PAB_IB2	State
0	0	PAbuffer uses bias current from PTAT bias source, external resistor (Pin 6)
0	1	PAbuffer uses bias current from CI bias source, external resistor (Pin 24)
1	0	PAbuffer uses bias current from internal bias source, PTAT
1	1	PAbuffer uses bias current from internal bias source, PTAT + CI
PAB_IB1	PAB_IB0	State
0	0	PAbuffer bias current setting, lowest bias current
0	1	PAbuffer bias current setting
1	0	PAbuffer bias current setting
1	1	PAbuffer bias current setting, highest bias current

**Table 51. PA and PAbuffer Bias Current Setting.**

LF_High_PM	LF_CAP1	LF_CAP0	C1	C2	Max. achievable Phase Margin
X	0	0	5.4pF	1.8pF	57°
0	0	1	10.8pF	3.6pF	57°
0	1	0	21.6pF	7.2pF	57°
0	1	1	32.4pF	10.8pF	57°
1	0	1	10.8pF	1.8pF	69°
1	1	0	21.6pF	3.6pF	69°
1	1	1	32.4pF	5.4pF	69°

**Table 52. Loop Filter Capacitors Values.**

LF_RES1<4:0> LF_RES3<4:0>	R1 (k $\Omega$ )	R3 (k $\Omega$ )
0	24.1	5.9
1	34.3	12.3
2	44.5	18.7
3	54.7	25.1
4	64.9	31.5
5	75.1	37.9
6	85.3	44.3
7	95.5	50.7
8	105.7	57.1
9	115.9	63.5
10	126.1	69.9
11	136.3	76.3
12	146.5	82.7
13	156.7	89.1
14	166.9	95.5
15	177.1	101.9
16	187.3	108.3
17	197.5	114.7
18	207.7	121.1
19	217.9	127.5
20	228.1	133.9
21	238.3	140.3
22	248.5	146.7
23	258.7	153.0
24	268.9	159.4
25	279.1	165.8
26	289.3	172.2
27	299.5	178.6
28	309.7	185.0
29	319.9	191.4
30	330.1	197.8
31	340.4	204.2

Table 53. Loop Filter Resistor Values.

### Typical Application Circuit

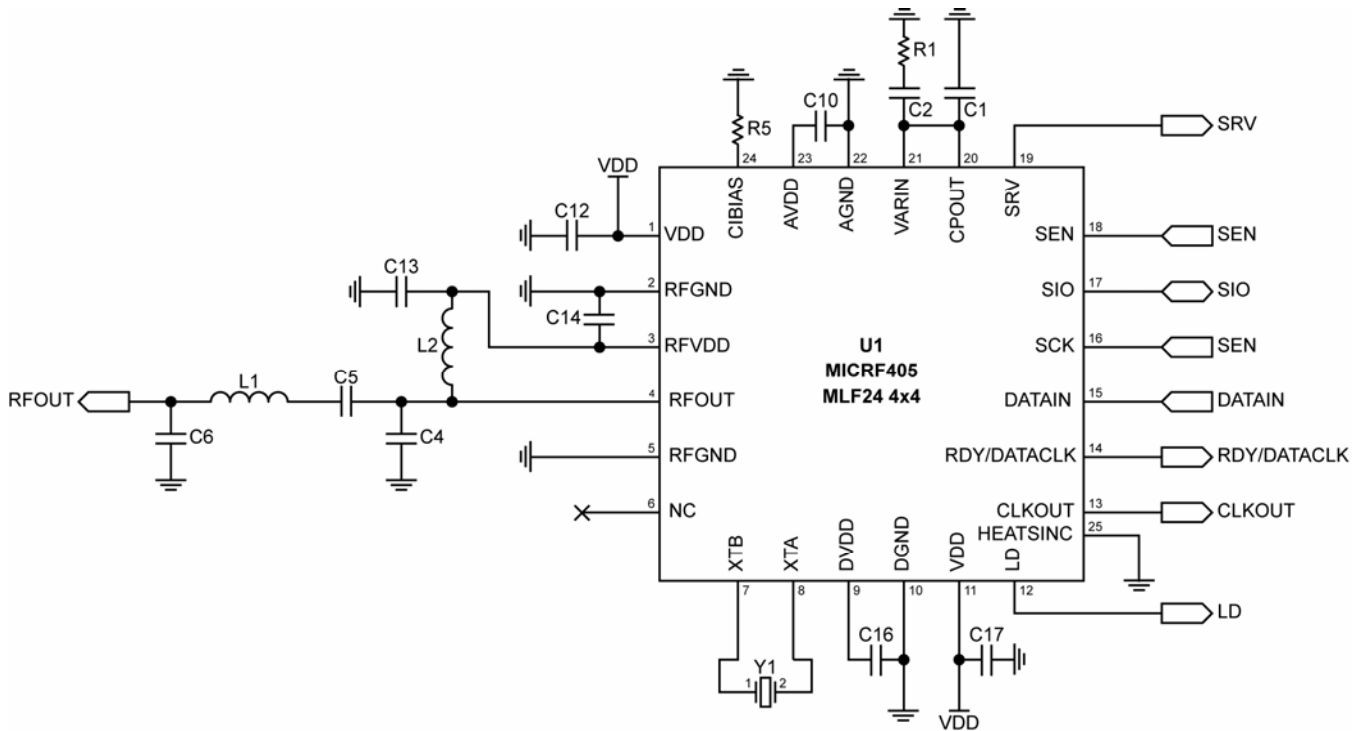

Figure 16. Typical Application Circuit

### Bill of Materials

FSK/ASK 915MHz					
Item	Part	Value	Description	Manufacturer	Part Number
1	C1	-	See Table 17		
2	C2	-	See Table 17		
3	C4	3p3	Capacitor, 0603, ±0.25pF, COG, 50V, -55,+125°C	Kyocera	CM105CG3R3C50A
4	C5	100pF	Capacitor, 0603, ±5%, COG, 50V, -55,+85°C	Kyocera	CM105CG101J50A
5	C6	3p3	Capacitor, 0603, ±0.25pF, COG, 50V, -55,+125°C	Kyocera	CM105CG3R3C50A
6	C10	100nF	Capacitor, 0603, ±10%, X7R, 16V, -55,+125°C	Kyocera	CM105X7R104K16A
7	C12	10nF	Capacitor, 0603, ±10%, X7R, 50V, -55,+125°C	Kyocera	CM105X7R103K50A
8	C13	100nF	Capacitor, 0603, ±10%, X7R, 16V, -55,+125°C	Kyocera	CM105X7R104K16A
9	C14	100nF	Capacitor, 0603, ±10%, X7R, 16V, -55,+125°C	Kyocera	CM105X7R104K16A
10	C16	100nF	Capacitor, 0603, ±10%, X7R, 16V, -55,+125°C	Kyocera	CM105X7R104K16A
11	C17	10nF	Capacitor, 0603, ±10%, X7R, 50V, -55,+125°C	Kyocera	CM105X7R103K50A
12	R1	-	See Table 17		
13	R5	82k	Resistor, 0603, ±1%, 50V, -55,+125°C	Kyocera	CR10-8202F
14	L1	10nH	Inductor, 0603, ±5%, -40,+125°C	Coilcraft	0603CS-10NXJB
15	L2	12nH	Inductor, 0603, ±5%, -40,+125°C	Coilcraft	0603CS-12NXJB
16	Y1	16MHz	Crystal, TSX-10A, ±10ppm, -20,+75°C	Toyocom	TN4-26011

FSK/ASK 868MHz					
Item	Part	Value	Description	Manufacturer	Part Number
1	C1	-	See Table 17		
2	C2	-	See Table 17		
3	C4	3p9	Capacitor, 0603, $\pm 0.25\text{pF}$ , COG, 50V, -55,+125°C	Kyocera	CM105CG3R9C50A
4	C5	15pF	Capacitor, 0603, $\pm 5\%$ , COG, 50V, -55,+85°C	Kyocera	CM105CG150J50A
5	C6	6p8	Capacitor, 0603, $\pm 0.5\text{pF}$ , COG, 50V, -55,+125°C	Kyocera	CM105CG6R8D50A
6	C10	100nF	Capacitor, 0603, $\pm 10\%$ , X7R, 16V, -55,+125°C	Kyocera	CM105X7R104K16A
7	C12	10nF	Capacitor, 0603, $\pm 10\%$ , X7R, 50V, -55,+125°C	Kyocera	CM105X7R103K50A
8	C13	100nF	Capacitor, 0603, $\pm 10\%$ , X7R, 16V, -55,+125°C	Kyocera	CM105X7R104K16A
9	C14	100nF	Capacitor, 0603, $\pm 10\%$ , X7R, 16V, -55,+125°C	Kyocera	CM105X7R104K16A
10	C16	100nF	Capacitor, 0603, $\pm 10\%$ , X7R, 16V, -55,+125°C	Kyocera	CM105X7R104K16A
11	C17	10nF	Capacitor, 0603, $\pm 10\%$ , X7R, 50V, -55,+125°C	Kyocera	CM105X7R103K50A
12	R1	-	See Table 17		
13	R5	82k	Resistor, 0603, $\pm 1\%$ , 50V, -55,+125°C	Kyocera	CR10-8202F
14	L1	10nH	Inductor, 0603, $\pm 5\%$ , -40,+125°C	Coilcraft	0603CS-10NXJB
15	L2	12nH	Inductor, 0603, $\pm 5\%$ , -40,+125°C	Coilcraft	0603CS-12NXJB
16	Y1	16MHz	Crystal, TSX-10A, $\pm 10\text{ppm}$ , -20,+75°C	Toyocom	TN4-26011

FSK/ASK 433MHz					
Item	Part	Value	Description	Manufacturer	Part Number
1	C1	-	See Table 17		
2	C2	-	See Table 17		
3	C4	5p6	Capacitor, 0603, $\pm 0.5\text{pF}$ COG, 50V, -55,+125°C	Kyocera	CM105CG5R6D50A
4	C5	6p8	Capacitor, 0603, $\pm 0.5\text{pF}$ , COG, 50V, -55,+85°C	Kyocera	CM105CG6R8D50A
5	C6	6p8	Capacitor, 0603, $\pm 0.5\text{pF}$ , COG, 50V, -55,+125°C	Kyocera	CM105CG6R8D50A
6	C10	100nF	Capacitor, 0603, $\pm 10\%$ , X7R, 16V, -55,+125°C	Kyocera	CM105X7R104K16A
7	C12	10nF	Capacitor, 0603, $\pm 10\%$ , X7R, 50V, -55,+125°C	Kyocera	CM105X7R103K50A
8	C13	100nF	Capacitor, 0603, $\pm 10\%$ , X7R, 16V, -55,+125°C	Kyocera	CM105X7R104K16A
9	C14	100nF	Capacitor, 0603, $\pm 10\%$ , X7R, 16V, -55,+125°C	Kyocera	CM105X7R104K16A
10	C16	100nF	Capacitor, 0603, $\pm 10\%$ , X7R, 16V, -55,+125°C	Kyocera	CM105X7R104K16A
11	C17	10nF	Capacitor, 0603, $\pm 10\%$ , X7R, 50V, -55,+125°C	Kyocera	CM105X7R103K50A
12	R1	-	See Table 17		
13	R5	82k	Resistor, 0603, $\pm 1\%$ , 50V, -55,+125°C	Kyocera	CR10-8202F
14	L1	47nH	Inductor, 0603, $\pm 5\%$ , -40,+125°C	Coilcraft	0603CS-47NXJB
15	L2	47nH	Inductor, 0603, $\pm 5\%$ , -40,+125°C	Coilcraft	0603CS-47NXJB
16	Y1	16MHz	Crystal, TSX-10A, $\pm 10\text{ppm}$ , -20,+75°C	Toyocom	TN4-26011

<b>FSK/ASK 315MHz</b>					
<b>Item</b>	<b>Part</b>	<b>Value</b>	<b>Description</b>	<b>Manufacturer</b>	<b>Part Number</b>
1	C1	-	See Table 17		
2	C2	-	See Table 17		
3	C4	10p	Capacitor, 0603, $\pm 5\%$ , COG, 50V, -55,+125°C	Kyocera	CM105CG100J50A
4	C5	100pF	Capacitor, 0603, $\pm 5\%$ , COG, 50V, -55,+85°C	Kyocera	CM105CG101J50A
5	C6	10p	Capacitor, 0603, $\pm 5\%$ , COG, 50V, -55,+125°C	Kyocera	CM105CG100J50A
6	C10	100nF	Capacitor, 0603, $\pm 10\%$ , X7R, 16V, -55,+125°C	Kyocera	CM105X7R104K16A
7	C12	10nF	Capacitor, 0603, $\pm 10\%$ , X7R, 50V, -55,+125°C	Kyocera	CM105X7R103K50A
8	C13	100nF	Capacitor, 0603, $\pm 10\%$ , X7R, 16V, -55,+125°C	Kyocera	CM105X7R104K16A
9	C14	100nF	Capacitor, 0603, $\pm 10\%$ , X7R, 16V, -55,+125°C	Kyocera	CM105X7R104K16A
10	C16	100nF	Capacitor, 0603, $\pm 10\%$ , X7R, 16V, -55,+125°C	Kyocera	CM105X7R104K16A
11	C17	10nF	Capacitor, 0603, $\pm 10\%$ , X7R, 50V, -55,+125°C	Kyocera	CM105X7R103K50A
12	R1	-	See Table 17		
13	R5	82k	Resistor, 0603, $\pm 1\%$ , 50V, -55,+125°C	Kyocera	CR10-8202F
14	L1	47nH	Inductor, 0603, $\pm 5\%$ , -40,+125°C	Coilcraft	0603CS-47NXJB
15	L2	47nH	Inductor, 0603, $\pm 5\%$ , -40,+125°C	Coilcraft	0603CS-47NXJB
16	Y1	16MHz	Crystal, TSX-10A, $\pm 10$ ppm, -20,+75°C	Toyocom	TN4-26011

### Package Information

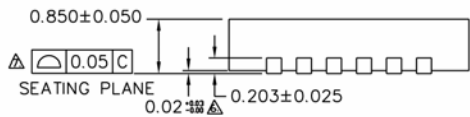
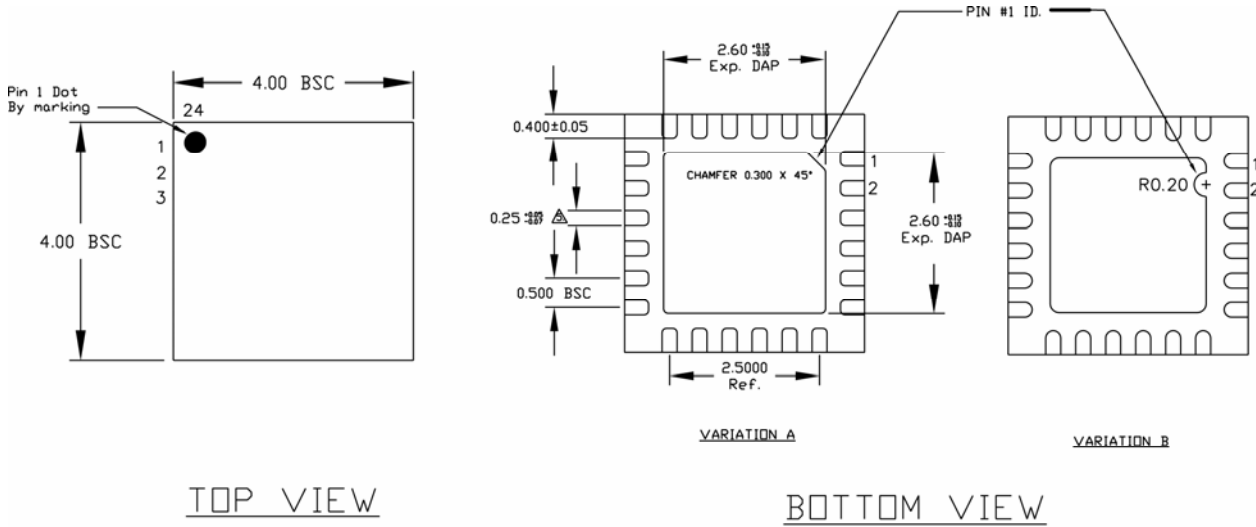

- NOTE:
1. ALL DIMENSIONS ARE IN MILLIMETERS.
  2. MAX. PACKAGE WARPAGE IS 0.05 mm.
  3. MAXIMUM ALLOWABLE BURRS IS 0.076 mm IN ALL DIRECTIONS.
  4. PIN #1 ID ON TOP WILL BE LASER/INK MARKED. DIMENSION APPLIES TO METALIZED TERMINAL AND IS MEASURED BETWEEN 0.20 AND 0.25 mm FROM TERMINAL TIP.
- APPLIED ONLY FOR TERMINALS.  
 APPLIED FOR EXPOSED PAD AND TERMINALS.

SIDE VIEW

Rev	ECN
A	071404HC01
B	092805HC05

### 24-Lead MLF<sup>®</sup> (ML)

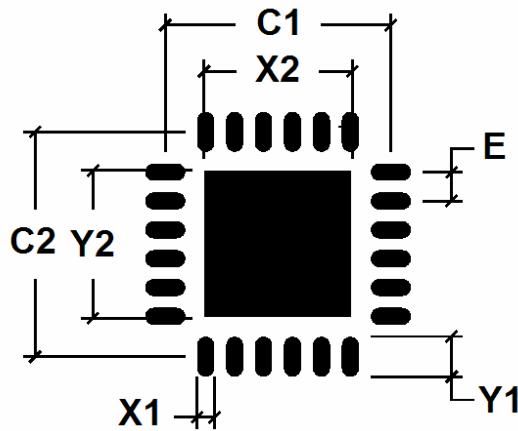

MLF <sup>®</sup> 4 4x4mm Land pattern							
	E	X1	Y1	C1	C2	X2	Y2
Min	0.50	0.30	0.70	3.90	3.90	2.55	2.55

---

**MICREL, INC. 2180 FORTUNE DRIVE SAN JOSE, CA 95131 USA**  
TEL +1 (408) 944-0800 FAX +1 (408) 474-1000 WEB <http://www.micrel.com>



The information furnished by Micrel in this data sheet is believed to be accurate and reliable. However, no responsibility is assumed by Micrel for its use. Micrel reserves the right to change circuitry and specifications at any time without notification to the customer.

Micrel Products are not designed or authorized for use as components in life support appliances, devices or systems where malfunction of a product can reasonably be expected to result in personal injury. Life support devices or systems are devices or systems that (a) are intended for surgical implant into the body or (b) support or sustain life, and whose failure to perform can be reasonably expected to result in a significant injury to the user. A Purchaser's use or sale of Micrel Products for use in life support appliances, devices or systems is a Purchaser's own risk and Purchaser agrees to fully indemnify Micrel for any damages resulting from such use or sale.

© 2006 Micrel, Incorporated.

## Looking for pricing, stock, or lifecycle information?

Click below to explore more details on WIN SOURCE:

-  [View MICRF405YML-TR on WIN SOURCE](#)
-  [Microchip Technology](#) Information

## Optimize Your Supply Chain with WIN SOURCE Solutions

-  Global Sourcing Solution
-  Obsolete Management
-  Cost Control Management
-  Shortage Management
-  Alternative Solution
-  Excess Inventory Management