



## MIC7111

1.8V to 11V, 15 $\mu$ A, 25kHz GBW, Rail-to-Rail  
Input and Output Operational Amplifier

### General Description

The MIC7111 is a low-power operational amplifier with rail-to-rail inputs and outputs. The device operates from a 1.8V to 11V single supply or an  $\pm 0.9V$  to  $\pm 5.5V$  dual supply. The device consumes a low 15 $\mu$ A of current from a 1.8V supply and 25 $\mu$ A from a 10V supply. The device features a unity gain bandwidth of 25kHz and swings within 1mV of either the supply rail with a 100k $\Omega$  load. The device is capable of sinking and sourcing 25mA of current from a 1.8V supply and up to 200mA from a 10V supply. The device is available in the cost effective SOT23-5 package.

Datasheets and support documentation are available on Micrel's web site at: [www.micrel.com](http://www.micrel.com).

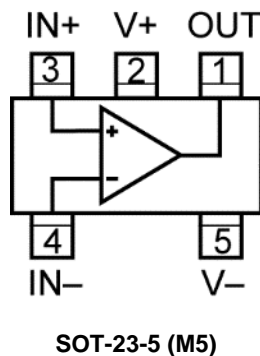
### Features

- 1.8V to 11V single supply operation
- $\pm 0.9V$  to  $\pm 5.5V$  dual supply operation
- Low 15 $\mu$ A supply current at 1.8V
- 25kHz gain bandwidth
- 1mV input offset voltage (typical)
- 1pA input bias current (typical)
- 0.01pA input offset current (typical)
- Input-referred noise is 110nv/ $\sqrt{\text{Hz}}$  at 1kHz
- Output swing to within 1mV of rails with 1.8V supply and 100k $\Omega$  load
- Suitable for driving capacitive loads
- Cost effective SOT23-5 package

### Applications

- Wireless and cellular communications
- GaAs RF bias amplifier
- Current sensing for battery chargers
- Transducer linearization and interface
- Portable computing

### Functional Configuration



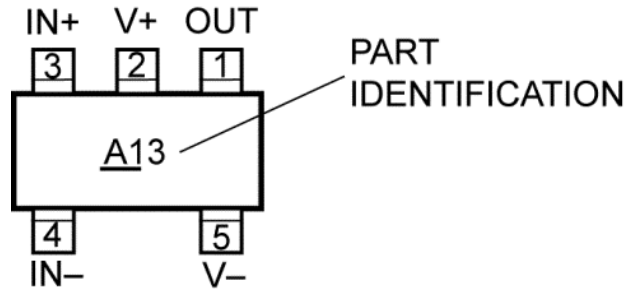
### Ordering Information

Part Number	Junction Temperature Range	Package <sup>(1)</sup>
Pb-Free		
MIC7111YM5	-40°C to +85°C	SOT23-5

**Note:**

1. Other packages are available. Contact Micrel for details.

### Pin Configuration



SOT23-5 (M5)  
(Top View)

### Pin Description

Pin Number	Pin Name	Pin Function
1	OUT	Amplifier Output.
2	V+	Positive Supply
3	IN+	Non-inverting Input.
4	IN-	Inverting Input
5	V-	Negative Supply.

**Absolute Maximum Ratings<sup>(1)</sup>**

Supply Voltage ( $V_{V+} - V_{V-}$ )	+12V
Differential Input Voltage ( $V_{IN+} - V_{IN-}$ )	$\pm(V_{V+} - V_{V-})$
I/O Pin Voltage ( $V_{IN}, V_{OUT}$ ) <sup>(3)</sup>	$V_{V+} + 0.3V$ to $V_{V-} - 0.3V$
Junction Temperature ( $T_J$ )	+150°C
Lead Temperature (soldering, 10s)	260°C
Storage Temperature ( $T_s$ )	-65°C to +150°C
ESD Rating <sup>(6)</sup>	2kV

**Operating Ratings<sup>(2)</sup>**

Supply Voltage ( $V_{V+} - V_{V-}$ )	+1.8V to +11V
Junction Temperature ( $T_J$ )	-40°C to +85°C
Maximum Junction Temperature ( $T_{J(MAX)}$ ) <sup>(4)</sup>	+85°C
Package Thermal Resistance ( $\theta_{JA}$ ) <sup>(5)</sup>	+252°C/W
Maximum Power Dissipation	Note 4

**DC Electrical Characteristics**

$V_{V+} = +1.8V$ ;  $V_{V-} = 0V$ ;  $V_{CM} = V_{OUT} = V_{V+}/2$ ;  $R_L = 1M$ ;  $T_J = +25^\circ C$ , **bold** values indicate  $-40^\circ C \leq T_J \leq +85^\circ C$ , unless noted.

Symbol	Parameter	Condition	Min.	Typ.	Max.	Units
$V_{OS}$	Input Offset Voltage			0.9	7	mV
					<b>9</b>	
$TCV_{OS}$	Input Offset Voltage Temperature Drift			2.0		$\mu V/^\circ C$
$I_B$	Input Bias Current			1	10	pA
					<b>500</b>	
$I_{OS}$	Input Offset Current			0.01	0.5	pA
					<b>75</b>	
$R_{IN}$	Input Resistance			>10		T $\Omega$
+PSRR	Positive Power Supply Rejection Ratio	$1.8V \leq V_{V+} \leq 5V$ , $V_{V-} = 0V$ , $V_{CM} = V_{OUT} = 0.9V$	60	85		dB
-PSRR	Negative Power Supply Rejection Ratio	$-1.8V \leq V_{V-} \leq -5V$ , $V_{V+} = 0V$ , $V_{CM} = V_{OUT} = -0.9V$	60	85		dB
CMRR	Common-Mode Rejection Ratio	$V_{CM} = -0.2V$ to $+2.0V$	50	70		dB
$C_{IN}$	Common-Mode Input Capacitance			3		pF
$V_{OUT}$	Output Voltage Swing	Output HIGH, $R_L = 100k$ , Specified as $V_{V+} - V_{OUT}$		0.14	1	mV
					<b>1</b>	
		Output LOW, $R_L = 100k$		0.14	1	
					<b>1</b>	
		Output HIGH, $R_L = 2k$ , Specified as $V_{V+} - V_{OUT}$		6.8	23	
					<b>34</b>	
		Output LOW, $R_L = 2k$		6.8	23	
					<b>34</b>	

**Notes:**

- Absolute maximum ratings indicate limits beyond which damage to the component may occur. Electrical specifications do not apply when operating the device outside its recommended operating ratings.
- The device is not guaranteed to function outside its operating ratings.
- I/O pin voltage is any external voltage to which an input or output is referenced.
- The maximum allowable power dissipation is a function of the maximum junction temperature,  $T_{J(MAX)}$ ; the junction-to-ambient thermal resistance,  $\theta_{JA}$ ; and the ambient temperature,  $T_A$ . The maximum allowable power dissipation at any ambient temperature is calculated using  $P_D = (T_{J(MAX)} - T_A) \div \theta_{JA}$ . Exceeding the maximum allowable power dissipation will result in excessive die temperature.
- Thermal resistance,  $\theta_{JA}$ , applies to a part soldered on a printed-circuit board.
- Devices are ESD protected, however, handling precautions are recommended. All limits guaranteed by testing on statistical analysis. Human body model, 1.5k $\Omega$  in series with 100pF.

## DC Electrical Characteristics (Continued)

$V_{V+} = +1.8V$ ;  $V_{V-} = 0V$ ;  $V_{CM} = V_{OUT} = V_{V+}/2$ ;  $R_L = 1M$ ;  $T_J = +25^\circ C$ , **bold** values indicate  $-40^\circ C \leq T_J \leq +85^\circ C$ , unless noted.

Symbol	Parameter	Condition	Min.	Typ.	Max.	Units
I <sub>SC</sub>	Output Short-Circuit Current <sup>(7)</sup>	Sourcing, $V_{OUT} = 0V$	15	25		mA
		Sinking, $V_{OUT} = 1.8V$	15	25		
A <sub>VOL</sub>	Voltage Gain	Sourcing		400		V/mV
		Sinking		400		
I <sub>S</sub>	Supply Current	$V_{V+} = 1.8V$ , $V_{OUT} = V_{V+}/2$		15	35	μA

## AC Electrical Characteristics

$V_{V+} = +1.8V$ ;  $V_{V-} = 0V$ ;  $V_{CM} = V_{OUT} = V_{V+}/2$ ;  $R_L = 1M$ ;  $T_J = +25^\circ C$ , **bold** values indicate  $-40^\circ C \leq T_J \leq +85^\circ C$ , unless noted.

Symbol	Parameter	Condition	Min.	Typ.	Max.	Units
SR	Slew Rate	Voltage follower, 1V step, $R_L = 100k$ @ 0.9V, $V_{OUT} = 1V_{P-P}$		0.015		V/μs
GBW	Gain Bandwidth Product	Sourcing		25		kHz

## DC Electrical Characteristics (2.7V)

$V_{V+} = +2.7V$ ;  $V_{V-} = 0V$ ;  $V_{CM} = V_{OUT} = V_{V+}/2$ ;  $R_L = 1M$ ;  $T_J = +25^\circ C$ , **bold** values indicate  $-40^\circ C \leq T_J \leq +85^\circ C$ , unless noted.

Symbol	Parameter	Condition	Min.	Typ.	Max.	Units
V <sub>OS</sub>	Input Offset Voltage			0.9	7	mV
				<b>9</b>		
TCV <sub>OS</sub>	Input Offset Voltage Temperature Drift			2.0		μV/°C
I <sub>B</sub>	Input Bias Current			1	10	pA
				<b>500</b>		
I <sub>OS</sub>	Input Offset Current			0.01	0.5	pA
				<b>75</b>		
R <sub>IN</sub>	Input Resistance			>10		TΩ
+PSRR	Positive Power Supply Rejection Ratio	$2.7V \leq V_{V+} \leq 5V$ , $V_{V-} = 0V$ , $V_{CM} = V_{OUT} = 1.35V$	60	90		dB
-PSRR	Negative Power Supply Rejection Ratio	$-2.7V \leq V_{V-} \leq -5V$ , $V_{V+} = 0V$ , $V_{CM} = V_{OUT} = -1.35V$	60	90		dB
CMRR	Common-Mode Rejection Ratio	$V_{CM} = -0.2V$ to $+2.9V$	52	75		dB
C <sub>IN</sub>	Common-Mode Input Capacitance			3		pF

**Note:**

7. Short circuit may cause the device to exceed maximum allowable power dissipation (see [Note 3](#)).

**DC Electrical Characteristics (2.7V) (Continued)**

$V_{V+} = +2.7V$ ;  $V_{V-} = 0V$ ;  $V_{CM} = V_{OUT} = V_{V+}/2$ ;  $R_L = 1M$ ;  $T_J = +25^{\circ}C$ , **bold** values indicate  $-40^{\circ}C \leq T_J \leq +85^{\circ}C$ , unless noted.

Symbol	Parameter	Condition	Min.	Typ.	Max.	Units
$V_{OUT}$	Output Voltage Swing	Output HIGH, $R_L = 100k$ , Specified as $V_{V+} - V_{OUT}$		0.2	1	mV
					<b>1</b>	
		Output LOW, $R_L = 100k$		0.2	1	
					<b>1</b>	
		Output HIGH, $R_L = 2k$ , Specified as $V_{V+} - V_{OUT}$		10	33	
				<b>50</b>		
		Output LOW, $R_L = 2k$		10	33	
					<b>50</b>	
$I_{SC}$	Output Short-Circuit Current <sup>(7)</sup>	Sourcing, $V_{OUT} = 0V$	30	50		mA
		Sinking, $V_{OUT} = 2.7V$	30	50		
$A_{VOL}$	Voltage Gain	Sourcing		400		V/mV
		Sinking		400		
$I_S$	Supply Current	$V_{V+} = 2.7V$ , $V_{OUT} = V_{V+}/2$		17	42	$\mu A$

**AC Electrical Characteristics (2.7V)**

$V_{V+} = +2.7V$ ;  $V_{V-} = 0V$ ;  $V_{CM} = V_{OUT} = V_{V+}/2$ ;  $R_L = 1M$ ;  $T_J = +25^{\circ}C$ , **bold** values indicate  $-40^{\circ}C \leq T_J \leq +85^{\circ}C$ , unless noted.

Symbol	Parameter	Condition	Min.	Typ.	Max.	Units
SR	Slew Rate	Voltage follower, 1V step, $R_L = 100k$ @ 1.35V, $V_{OUT} = 1V_{P-P}$		0.015		V/ $\mu s$
GBW	Gain Bandwidth Product	Sourcing		25		kHz

## DC Electrical Characteristics (5V)

$V_{V+} = +5V$ ;  $V_{V-} = 0V$ ;  $V_{CM} = V_{OUT} = V_{V+}/2$ ;  $R_L = 1M$ ;  $T_J = +25^\circ C$ , **bold** values indicate  $-40^\circ C \leq T_J \leq +85^\circ C$ , unless noted.

Symbol	Parameter	Condition	Min.	Typ.	Max.	Units
$V_{OS}$	Input Offset Voltage			0.9	7	mV
				<b>9</b>		
$TCV_{OS}$	Input Offset Voltage Temperature Drift			2.0		$\mu V/^\circ C$
$I_B$	Input Bias Current			1	10	pA
				<b>500</b>		
$I_{OS}$	Input Offset Current			0.01	0.5	pA
				<b>75</b>		
$R_{IN}$	Input Resistance			>10		T $\Omega$
+PSRR	Positive Power Supply Rejection Ratio	$5V \leq V_{V+} \leq 10V$ , $V_{V-} = 0V$ , $V_{CM} = V_{OUT} = 2.5V$	65	95		dB
-PSRR	Negative Power Supply Rejection Ratio	$-5V \leq V_{V-} \leq -10V$ , $V_{V+} = 0V$ , $V_{CM} = V_{OUT} = -2.5V$	65	95		dB
CMRR	Common-Mode Rejection Ratio	$V_{CM} = -0.2V$ to $+5.2V$	57	80		dB
$C_{IN}$	Common-Mode Input Capacitance			3		pF
$V_{OUT}$	Output Voltage Swing	Output HIGH, $R_L = 100k$ , Specified as $V_{V+} - V_{OUT}$		0.3	1.5	mV
				<b>1.5</b>		
		Output LOW, $R_L = 100k$		0.3	1.5	
				<b>1.5</b>		
		Output HIGH, $R_L = 2k$ , Specified as $V_{V+} - V_{OUT}$		15	50	
				<b>75</b>		
		Output LOW, $R_L = 2k$		15	50	
				<b>75</b>		
$I_{SC}$	Output Short-Circuit Current <sup>(7)</sup>	Sourcing, $V_{OUT} = 0V$	80	100		mA
		Sinking, $V_{OUT} = 5V$	80	100		
$A_{VOL}$	Voltage Gain	Sourcing		500		V/mV
		Sinking		500		
$I_S$	Supply Current	$V_{V+} = 5V$ , $V_{OUT} = V_{V+}/2$		20	50	$\mu A$

## AC Electrical Characteristics (5V)

$V_+ = +5V$ ;  $V_- = 0V$ ;  $V_{CM} = V_{OUT} = V_{V+}/2$ ;  $R_L = 1M$ ;  $T_J = +25^\circ C$ , **bold** values indicate  $-40^\circ C \leq T_J \leq +85^\circ C$ , unless noted.

Symbol	Parameter	Condition	Min.	Typ.	Max.	Units
SR	Slew Rate	Voltage follower, 1V step, $R_L = 100k$ @ 1.5V, $V_{OUT} = 1V_{P-P}$		0.02		V/ $\mu s$
GBW	Gain Bandwidth Product	Sourcing		25		kHz

## DC Electrical Characteristics (10V)

$V_{V+} = +10V$ ;  $V_{V-} = 0V$ ;  $V_{CM} = V_{OUT} = V_{V+}/2$ ;  $R_L = 1M$ ;  $T_J = +25^{\circ}C$ , **bold** values indicate  $-40^{\circ}C \leq T_J \leq +85^{\circ}C$ , unless noted.

Symbol	Parameter	Condition	Min.	Typ.	Max.	Units
$V_{OS}$	Input Offset Voltage			0.9	7	mV
					<b>9</b>	
$TCV_{OS}$	Input Offset Voltage Temperature Drift			2.0		$\mu V/^{\circ}C$
$I_B$	Input Bias Current			1	10	pA
					<b>500</b>	
$I_{OS}$	Input Offset Current			0.01	0.5	pA
					<b>75</b>	
$R_{IN}$	Input Resistance			>10		T $\Omega$
+PSRR	Positive Power Supply Rejection Ratio	$5V \leq V_{V+} \leq 10V$ , $V_{V-} = 0V$ , $V_{CM} = V_{OUT} = 2.5V$	65	95		dB
-PSRR	Negative Power Supply Rejection Ratio	$-5V \leq V_{V-} \leq -10V$ , $V_{V+} = 0V$ , $V_{CM} = V_{OUT} = -2.5V$	65	95		dB
CMRR	Common-Mode Rejection Ratio	$V_{CM} = -0.2V$ to $+10.2V$	60	85		dB
$C_{IN}$	Common-Mode Input Capacitance			3		pF
$V_{OUT}$	Output Voltage Swing	Output HIGH, $R_L = 100k$ , Specified as $V_{V+} - V_{OUT}$		0.45	2.5	mV
					<b>2.5</b>	
		Output LOW, $R_L = 100k$		0.45	2.5	
					<b>2.5</b>	
		Output HIGH, $R_L = 2k$ , Specified as $V_{V+} - V_{OUT}$		24	80	
					<b>120</b>	
		Output LOW, $R_L = 2k$		24	80	
					<b>120</b>	
$I_{SC}$	Output Short-Circuit Current <sup>(7)</sup>	Sourcing, $V_{OUT} = 0V$	100	200		mA
		Sinking, $V_{OUT} = 10V$	100	200		
$A_{VOL}$	Voltage Gain	Sourcing		500		V/mV
		Sinking		500		
$I_S$	Supply Current	$V_{V+} = 10V$ , $V_{OUT} = V_{V+}/2$		25	65	$\mu A$

## AC Electrical Characteristics (10V)

$V_+ = +10V$ ;  $V_- = 0V$ ;  $V_{CM} = V_{OUT} = V_{V+}/2$ ;  $R_L = 1M$ ;  $T_J = +25^\circ C$ , **bold** values indicate  $-40^\circ C \leq T_J \leq +85^\circ C$ , unless noted.

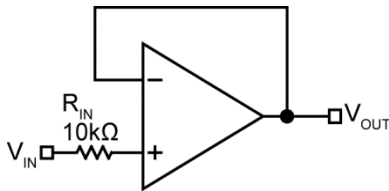
Symbol	Parameter	Condition	Min.	Typ.	Max.	Units
SR	Slew Rate	Voltage follower, 1V step, $R_L = 100k$ @ 1.35V $V_{OUT} = 1V_{P-P}$		0.02		V/ $\mu s$
GBW	Gain Bandwidth Product			25		kHz
$\phi_M$	Phase Margin			50		$^\circ$
$G_M$	Gain Margin			15		dB
$e_N$	Input-Referred Voltage Noise	$f = 1kHz$ , $V_{CM} = 1.0V$		110		$nV/\sqrt{Hz}$
$i_N$	Input-Referred Current Noise	$f = 1kHz$		0.03		$pA/\sqrt{Hz}$

## Application Information

### Input Common Mode Voltage

The MIC7111 tolerates input overdrive by at least 300mV beyond either rail without producing phase inversion.

If the absolute maximum input voltage is exceeded, the input current should be limited to  $\pm 5\text{mA}$  maximum to prevent reducing reliability. A  $10\text{k}\Omega$  series input resistor, used as a current limiter, will protect the input structure from voltages as large as 50V above the supply or below ground. See [Figure 1](#).



**Figure 1. Input Current-Limit Protection**

### Output Voltage Swing

Sink and source output resistances of the MIC7111 are equal. Maximum output voltage swing is determined by the load and the approximate output resistance. The output resistance is presented in Equation 1:

$$R_{OUT} = \frac{V_{DROP}}{I_{LOAD}} \quad \text{Eq. 1}$$

$V_{DROP}$  is the voltage dropped within the amplifier output stage.  $V_{DROP}$  and  $I_{LOAD}$  can be determined from the  $V_O$  (output swing) portion of the appropriate electrical characteristics table.  $I_{LOAD}$  is equal to the typical output high voltage minus  $V+/2$  and divided by  $R_{LOAD}$ . For example, using the *DC Electrical Characteristics (5V)* table, the typical output voltage drop using a  $2\text{k}\Omega$  load (connected to  $V+/2$ ) is 0.015V, which produces an  $I_{LOAD}$  of:

$$\frac{2.5\text{V} - 0.015\text{V}}{2\text{k}\Omega} = 1.243\text{mA} \quad \text{Eq. 2}$$

Then,

$$R_{OUT} = \frac{15\text{mV}}{1.243\text{mA}} = 12.1 = 12\Omega \quad \text{Eq. 3}$$

### Driving Capacitive Loads

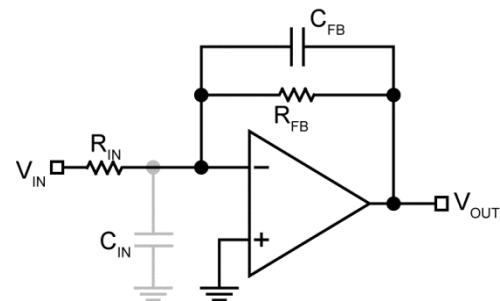
Driving a capacitive load introduces phase-lag into the output signal, and this in turn reduces op-amp system phase margin. The application that is least forgiving of reduced phase margin is a unity gain amplifier. The MIC7111 can typically drive a 500pF capacitive load connected directly to the output when configured as a unity-gain amplifier.

### Using Large-Value Feedback Resistors

A large-value feedback resistor ( $> 500\text{k}\Omega$ ) can reduce the phase margin of a system. This occurs when the feedback resistor acts in conjunction with input capacitance to create phase lag in the feedback signal. Input capacitance is usually a combination of input circuit components and other parasitic capacitance, such as amplifier input capacitance and stray printed circuit board capacitance.

[Figure 2](#) illustrates a method of compensating phase lag caused by using a large-value feedback resistor. Feedback capacitor  $C_{FB}$  introduces sufficient phase lead to overcome the phase lag caused by feedback resistor  $R_{FB}$  and input capacitance  $C_{IN}$ . The value of  $C_{FB}$  is determined by first estimating  $C_{IN}$  and then applying the following formula:

$$R_{IN} \times C_{IN} \leq R_{FB} \times C_{FB} \quad \text{Eq. 4}$$

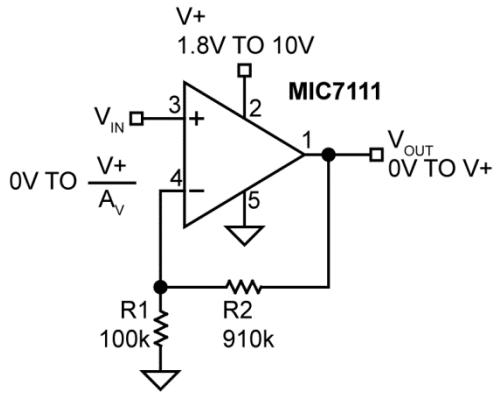


**Figure 2. Cancelling Feedback Phase Lag**

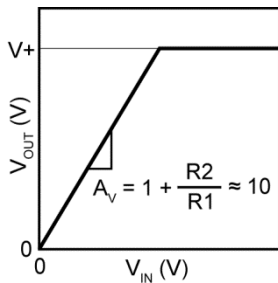
Since a significant percentage of  $C_{IN}$  may be caused by board layout, it is important to note that the correct value of  $C_{FB}$  may change when changing from a breadboard to the final circuit layout.

**Typical Circuits**

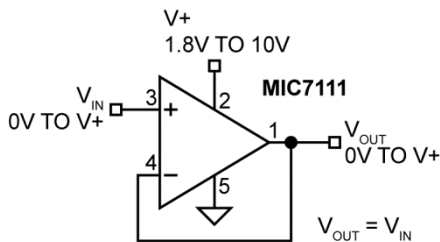
Some single-supply, rail-to-rail applications – for which the MIC7111 is well suited – are shown in the circuit diagrams of Figures 3 through 8.



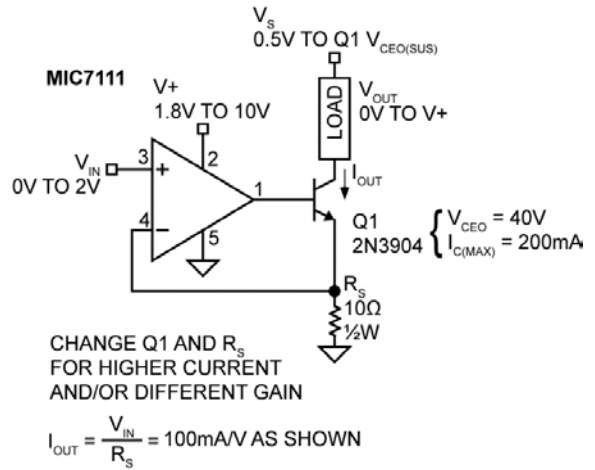
**Figure 3. Noninverting Amplifier**



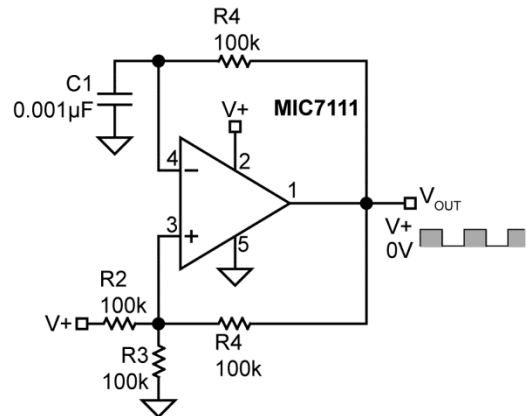
**Figure 4. Noninverting Amplifier Behavior**



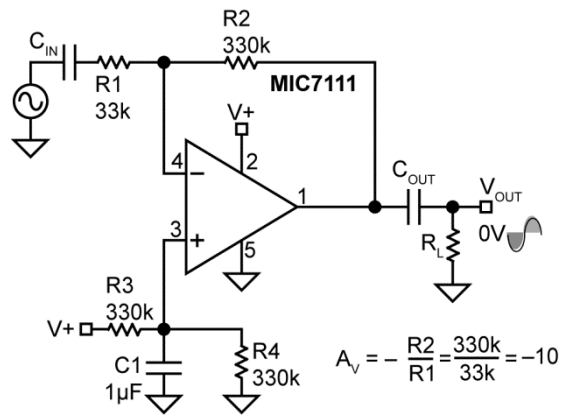
**Figure 5. Voltage Follower/Buffer**



**Figure 6. Voltage-Controlled Current Sink**

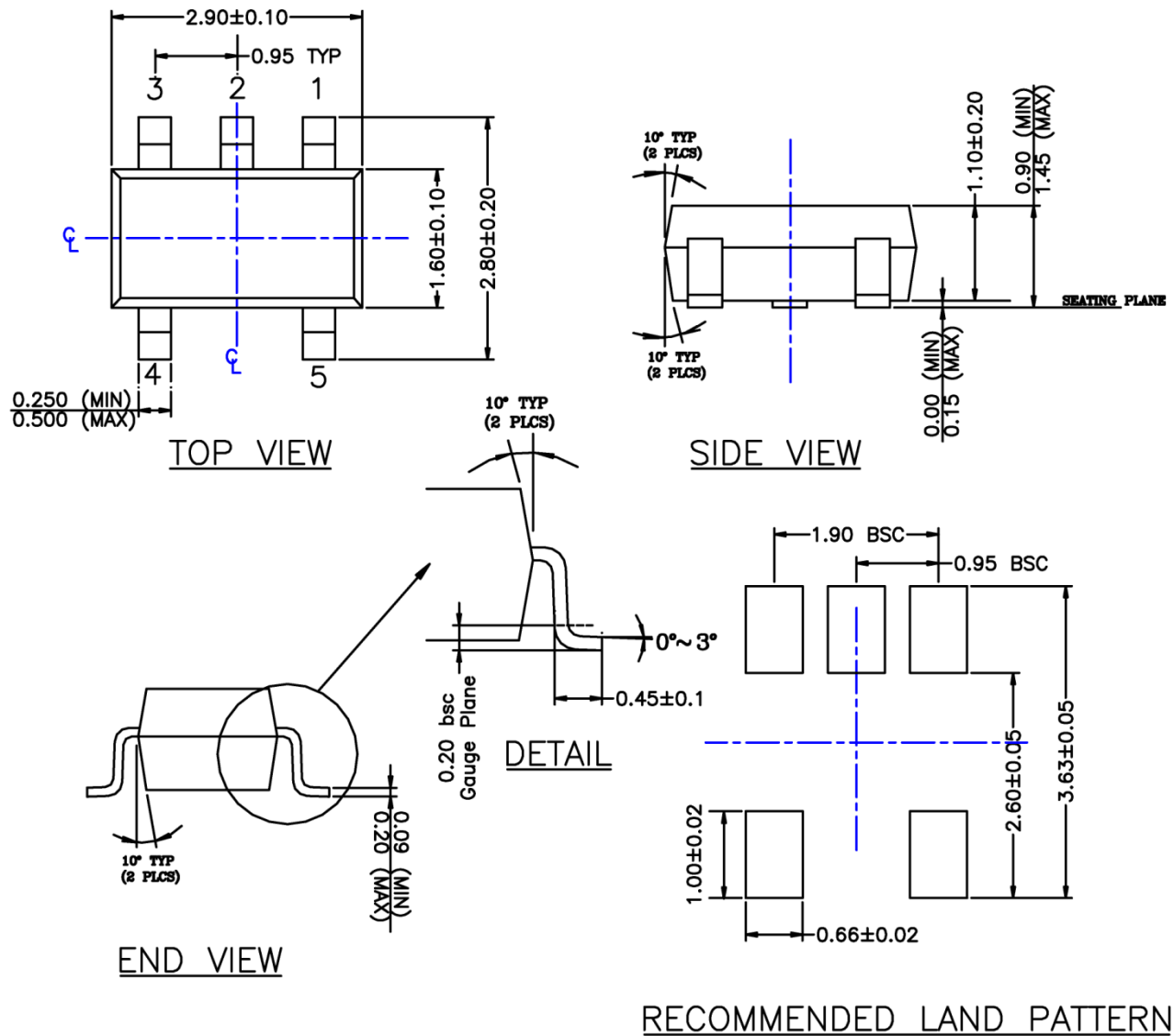


**Figure 7. Square Wave Oscillator**



**Figure 8. AC-Coupled Inverting Amplifier**

**Package Information<sup>(1)</sup> and Recommended Landing Pattern**



- NOTE:
1. PACKAGE OUTLINE EXCLUSIVE OF MOLD FLASH & BURR.
  2. PACKAGE OUTLINE INCLUSIVE OF SOLER PLATING.
  3. DIMENSION AND TOLERANCE PER ANSI Y14.5M, 1982.
  4. FOOT LENGTH MEASUREMENT BASED ON GAUGE PLANE METHOD.
  5. DIE FACES UP FOR MOLD, AND FACES DOWN FOR TRIM/FORM.
  6. ALL DIMENSIONS ARE IN MILLIMETERS.

**SOT23-5 (M5)**

**Note:**

1. Package information is correct as of the publication date. For updates and most current information, go to [www.micrel.com](http://www.micrel.com).

---

**MICREL, INC. 2180 FORTUNE DRIVE SAN JOSE, CA 95131 USA**TEL +1 (408) 944-0800 FAX +1 (408) 474-1000 WEB <http://www.micrel.com>

Micrel makes no representations or warranties with respect to the accuracy or completeness of the information furnished in this data sheet. This information is not intended as a warranty and Micrel does not assume responsibility for its use. Micrel reserves the right to change circuitry, specifications and descriptions at any time without notice. No license, whether express, implied, arising by estoppel or otherwise, to any intellectual property rights is granted by this document. Except as provided in Micrel's terms and conditions of sale for such products, Micrel assumes no liability whatsoever, and Micrel disclaims any express or implied warranty relating to the sale and/or use of Micrel products including liability or warranties relating to fitness for a particular purpose, merchantability, or infringement of any patent, copyright or other intellectual property right.

Micrel Products are not designed or authorized for use as components in life support appliances, devices or systems where malfunction of a product can reasonably be expected to result in personal injury. Life support devices or systems are devices or systems that (a) are intended for surgical implant into the body or (b) support or sustain life, and whose failure to perform can be reasonably expected to result in a significant injury to the user. A Purchaser's use or sale of Micrel Products for use in life support appliances, devices or systems is a Purchaser's own risk and Purchaser agrees to fully indemnify Micrel for any damages resulting from such use or sale.

© 2005 Micrel, Incorporated.

## Looking for pricing, stock, or lifecycle information?

Click below to explore more details on WIN SOURCE:

-  [View MIC7111BM5 on WIN SOURCE](#)
-  [Microchip Technology](#) Information

## Optimize Your Supply Chain with WIN SOURCE Solutions

-  Global Sourcing Solution
-  Obsolete Management
-  Cost Control Management
-  Shortage Management
-  Alternative Solution
-  Excess Inventory Management