



THE DATASHEET OF MIC5842BWM





MIC5841/5842

8-Bit Serial-Input Latched Drivers

General Description

Using BiCMOS technology, the MIC5841/5842 integrated circuits were fabricated to be used in a wide variety of peripheral power driver applications. The devices each have an eight-bit CMOS shift register, CMOS control circuitry, eight CMOS data latches, and eight bipolar current-sink Darlington output drivers.

These two devices differ only in maximum voltage ratings. The MIC5842 offers premium performance with a minimum output breakdown voltage rating of 80V (50V sustaining). The drivers can be operated with a split supply where the negative supply is down to -20V.

The 500mA outputs, with integral transient-suppression diodes, are suitable for use with lamps, relays, solenoids and other inductive loads.

These devices have improved speed characteristics. With a 5V logic supply, they will typically operate faster than 5 MHz. With a 12V supply, significantly higher speeds are obtained. The CMOS inputs are compatible with standard CMOS, PMOS, and NMOS logic levels. TTL or DTL circuits may require the use of appropriate pull-up resistors. By using the serial data output, the drivers can be cascaded for interface applications requiring additional drive lines.

The MIC5840 family is available in DIP, PLCC, and SOIC packages. Because of limitations on package power dissipation, the simultaneous operation of all drivers at maximum rated current might require a reduction in duty cycle. A copper-alloy lead frame provides for maximum package power dissipation.

Features

- 3.3 MHz Minimum Data-Input Rate
- CMOS, PMOS, NMOS, TTL Compatible
- Internal Pull-Up/Pull-Down Resistors
- Low-Power CMOS Logic and Latches
- High-Voltage Current-Sink Outputs
- Output Transient-Protection Diodes
- Single or Split Supply Operation

Ordering Information

Part Number		Temperature Range	Package
Standard	Pb-Free		
MIC5841BN	MIC5841YN	-40°C to +85°C	18-Pin Plastic DIP
MIC5841BV	MIC5841YV	-40°C to +85°C	20-Pin PLCC
MIC5841BWM	MIC5841YWM	-40°C to +85°C	18-Pin Wide SOIC
MIC5842BN	MIC5842YN	-40°C to +85°C	18-Pin Plastic DIP
MIC5842BV	MIC5842YV	-40°C to +85°C	20-Pin PLCC
MIC5842BWM	MIC5842YWM	-40°C to +85°C	18-Pin Wide SOIC

Functional Diagram

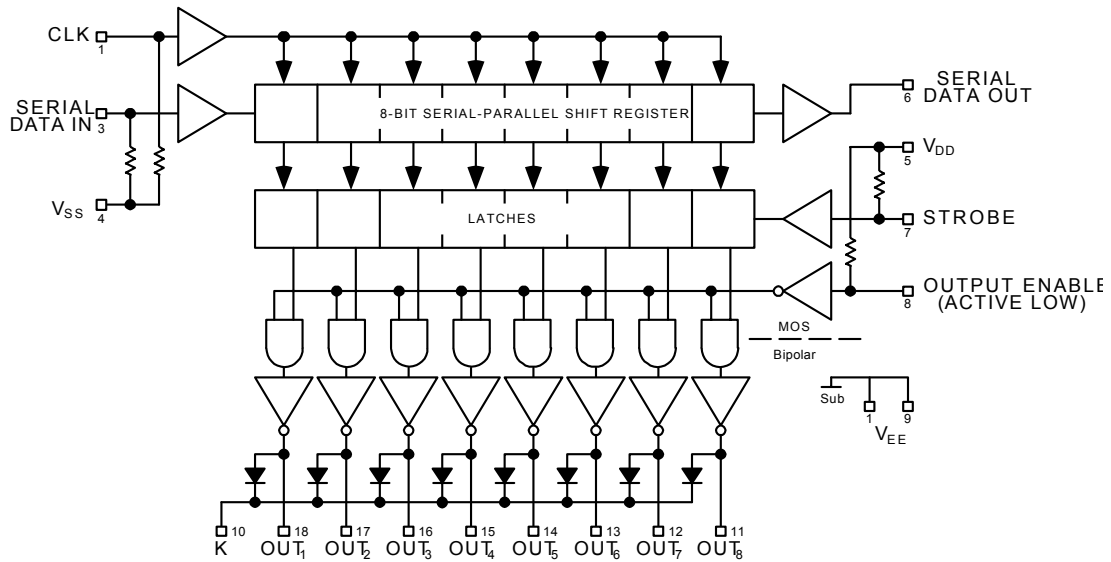

Pin Configuration

(20-Pin PLCC) Top View.

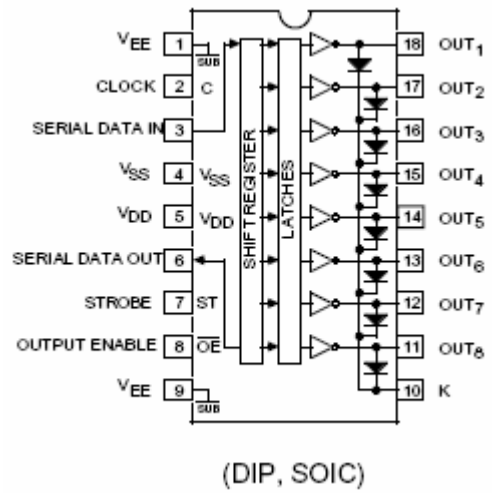
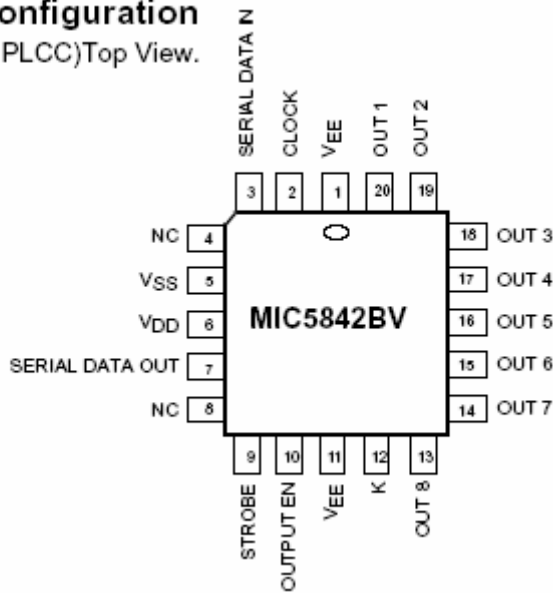

Absolute Maximum Ratings^(1,2,3)

At 25°C Free-Air Temperature and $V_{SS} = 0V$

Output Voltage, V_{CE} (MIC5841)	50V
(MIC5842)	80V
Output Voltage, $V_{CE(SUS)}$ (MIC5841) ⁽¹⁾	35V
(MIC5842)	50V
Logic Supply Voltage, V_{DD}	15V
VDD with Reference to V_{EE}	25V

Emitter Supply Voltage, V_{EE}	-20V
Input Voltage Range, V_{IN}	-0.3V to $V_{DD} + 0.3V$
Continuous Output Current, I_{OUT}	500mA
Package Power Dissipation, P_D ⁽²⁾	1.82W
Operating Temperature Range, T_A	-55°C to +85°C
Storage Temperature Range, T_S	-65°C to +150°C

Electrical Characteristics

At $T_A = 25^\circ C$, $V_{DD} = 5V$, $V_{SS} = V_{EE} = 0V$ (unless otherwise noted)

Characteristic	Symbol	Applicable Devices	Test Conditions	Limits		
				Min	Max	Unit
Output Leakage Current	I_{CEX}	MIC5841	$V_{OUT} = 50V$		50	μA
			$V_{OUT} = 50V, T_A = +70^\circ C$		100	
		MIC5842	$V_{OUT} = 80V$		50	
			$V_{OUT} = 80V, T_A = +70^\circ C$		100	
Collector-Emitter Saturation Voltage	$V_{CE(SAT)}$	Both	$I_{OUT} = 100mA$		1.1	V
			$I_{OUT} = 200mA$		1.3	
			$I_{OUT} = 350mA, V_{DD} = 7.0V$		1.6	
Collector-Emitter Saturation Voltage	$V_{CE(SUS)}^{(5)}$	MIC5841	$I_{OUT} = 350mA, L = 2mH$	35		V
		MIC5842	$I_{OUT} = 350mA, L = 2mH$	50		
Input Voltage	$V_{IN(0)}$	Both			0.8	V
	$V_{IN(1)}$	Both	$V_{DD} = 12V$	10.5		
			$V_{DD} = 10V$	8.5		
Input Resistance	R_{IN}	Both	$V_{DD} = 12V$	50		$k\Omega$
			$V_{DD} = 10V$	50		
			$V_{DD} = 5.0V$	50		
Supply Current	$I_{DD(ON)}$	Both	All Drivers ON, $V_{DD} = 12V$		16	1.6
			All Drivers ON, $V_{DD} = 10V$		14	
			All Drivers ON, $V_{DD} = 5.0V$		8.0	
	$I_{DD(OFF)}$	Both	All Drivers OFF, $V_{DD} = 12V$		2.9	
			All Drivers OFF, $V_{DD} = 10V$		2.5	
			All Drivers OFF, $V_{DD} = 5.0V$		1.6	
Clamp Diode Leakage Current	I_R	MIC5841	$V_R = 50V$		50	μA
		MIC5842	$V_R = 80V$		50	
Clamp Diode Forward Voltage	V_F	Both	$I_F = 350mA$		2.0	V

Electrical Characteristics

At $T_A = -55^\circ\text{C}$ $V_{DD} = 5\text{V}$, $V_{SS} = V_{EE} = 0\text{V}$ (unless otherwise noted)

Characteristic	Symbol	Test Conditions	Limits		
			Min	Max	Unit
Output Leakage Current	I_{CEX}	$V_{OUT} = 80\text{V}$		50	μA
Collector-Emitter Saturation Voltage	$V_{CE(SAT)}$	$I_{OUT} = 100\text{mA}$		1.3	V
		$I_{OUT} = 200\text{mA}$		1.5	
		$I_{OUT} = 350\text{mA}$, $V_{DD} = 7.0\text{V}$		1.8	
Input Voltage	$V_{IN(0)}$			0.8	V
	$V_{IN(1)}$	$V_{DD} = 12\text{V}$	10.5		
		$V_{DD} = 5.0\text{V}$	3.5		
Input Resistance	R_{IN}	$V_{DD} = 12\text{V}$	35		$\text{k}\Omega$
		$V_{DD} = 10\text{V}$	35		
		$V_{DD} = 5.0\text{V}$	35		
Supply Current	$I_{DD(ON)}$	All Drivers ON, $V_{DD} = 12\text{V}$		16	mA
		All Drivers ON, $V_{DD} = 10\text{V}$		14	
		All Drivers ON, $V_{DD} = 5.0\text{V}$		10	
	$I_{DD(OFF)}$	All Drivers OFF, $V_{DD} = 12\text{V}$		3.5	
		All Drivers OFF, $V_{DD} = 5.0\text{V}$		2.0	

Electrical Characteristics

At $T_A = +125^\circ\text{C}$ $V_{DD} = 5\text{V}$, $V_{SS} = V_{EE} = 0\text{V}$ (unless otherwise noted)

Characteristic	Symbol	Test Conditions	Limits		
			Min	Max	Unit
Output Leakage Current	I_{CEX}	$V_{OUT} = 80\text{V}$		500	μA
Collector-Emitter Saturation Voltage	$V_{CE(SAT)}$	$I_{OUT} = 100\text{mA}$		1.3	V
		$I_{OUT} = 200\text{mA}$		1.5	
		$I_{OUT} = 350\text{mA}$, $V_{DD} = 7.0\text{V}$		1.8	
Input Voltage	$V_{IN(0)}$			0.8	V
	$V_{IN(1)}$	$V_{DD} = 12\text{V}$	10.5		
		$V_{DD} = 5.0\text{V}$	3.5		
Input Resistance	R_{IN}	$V_{DD} = 12\text{V}$	50		$\text{k}\Omega$
		$V_{DD} = 10\text{V}$	50		
		$V_{DD} = 5.0\text{V}$	50		
Supply Current	$I_{DD(ON)}$	All Drivers ON, $V_{DD} = 12\text{V}$		16	mA
		All Drivers ON, $V_{DD} = 10\text{V}$		14	
		All Drivers ON, $V_{DD} = 5.0\text{V}$		8	
	$I_{DD(OFF)}$	All Drivers OFF, $V_{DD} = 12\text{V}$		2.9	
		All Drivers OFF, $V_{DD} = 5.0\text{V}$		2.1.6	
Clamp Diode Leakage Current	I_R	MIC5841A $V_R = 50\text{V}$		1.6	μA
		MIC5842A $V_R = 80\text{V}$		100	

Notes:

1. For Inductive load applications.
2. Derate at the rate of $18.2\text{mW}/^\circ\text{C}$ above $T_A = 25^\circ\text{C}$ (Plastic DIP)
3. CMOS devices have input-static protection but are susceptible to damage when exposed to extremely high static electrical charges.
4. Operation of these devices with standard TTL may require the use of appropriate pull-up resistors to insure an input logic HIGH.
5. Not 100% tested. Guaranteed by design.

Typical Output Driver

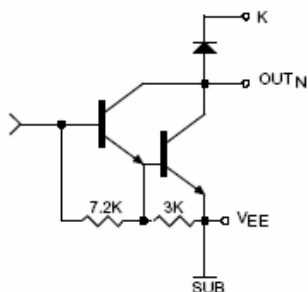

Typical Input Circuits

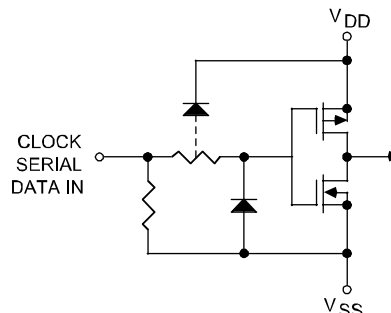
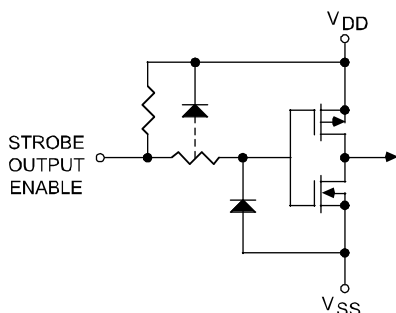

Maximum Allowable Duty Cycle (Plastic DIP)

$V_{DD} = 5.0V$

Number of Outputs ON ($I_{OUT} = 200mA$ $V_{DD} = 5.0V$)	Max. Allowable Duty Cycle at Ambient Temperature of				
	25°C	40°C	50°C	60°C	70°C
8	85%	72%	64%	55%	46%
7	97%	82%	73%	63%	53%
6	100%	96%	85%	73%	62%
5	100%	100%	100%	88%	75%
4	100%	100%	100%	100%	93%
3	100%	100%	100%	100%	100%
2	100%	100%	100%	100%	100%
1	100%	100%	100%	100%	100%

$V_{DD} = 12V$

Number of Outputs ON ($I_{OUT} = 200mA$ $V_{DD} = 12V$)	Max. Allowable Duty Cycle at Ambient Temperature of				
	25°C	40°C	50°C	60°C	70°C
8	80%	68%	60%	52%	44%
7	91%	77%	68%	59%	50%
6	100%	90%	79%	69%	58%
5	100%	100%	95%	82%	69%
4	100%	100%	100%	100%	86%
3	100%	100%	100%	100%	100%
2	100%	100%	100%	100%	100%
1	100%	100%	100%	100%	100%

Typical Applications

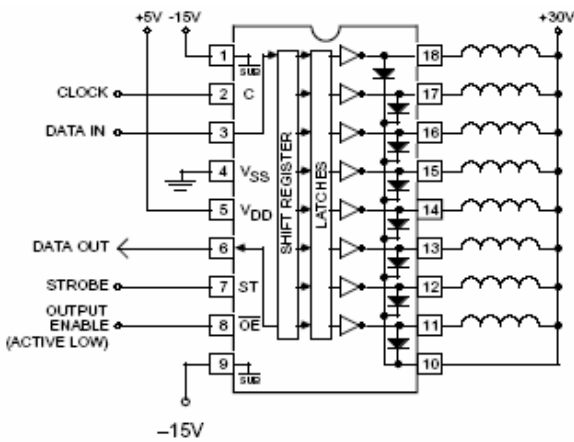

Relay/Solenoid Driver MIC5842

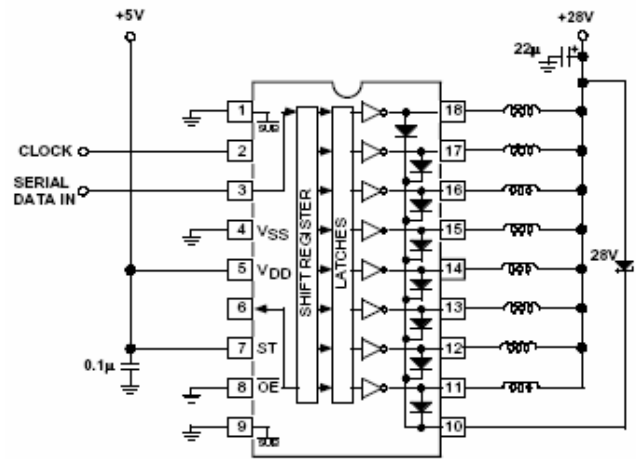

MIC5841 Hammer Driver

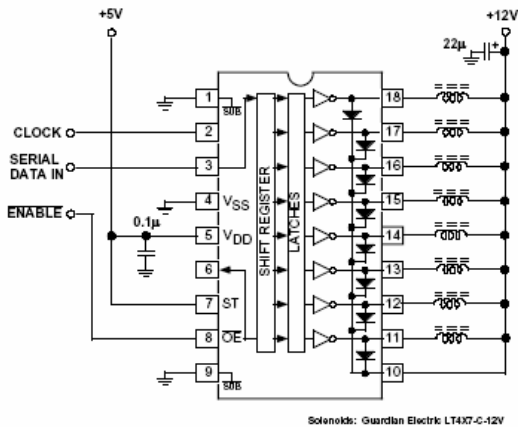

MIC5841 Solenoid Driver with Output Enable

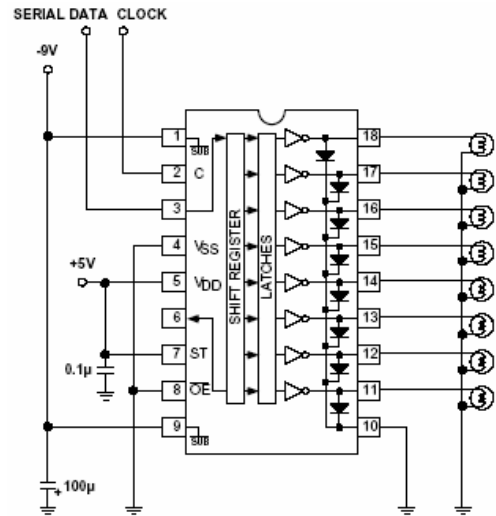

MIC5841 Level Shifting Lamp Driver with Darlington Emitters Tied to a Negative Supply

Typical Applications, Continued

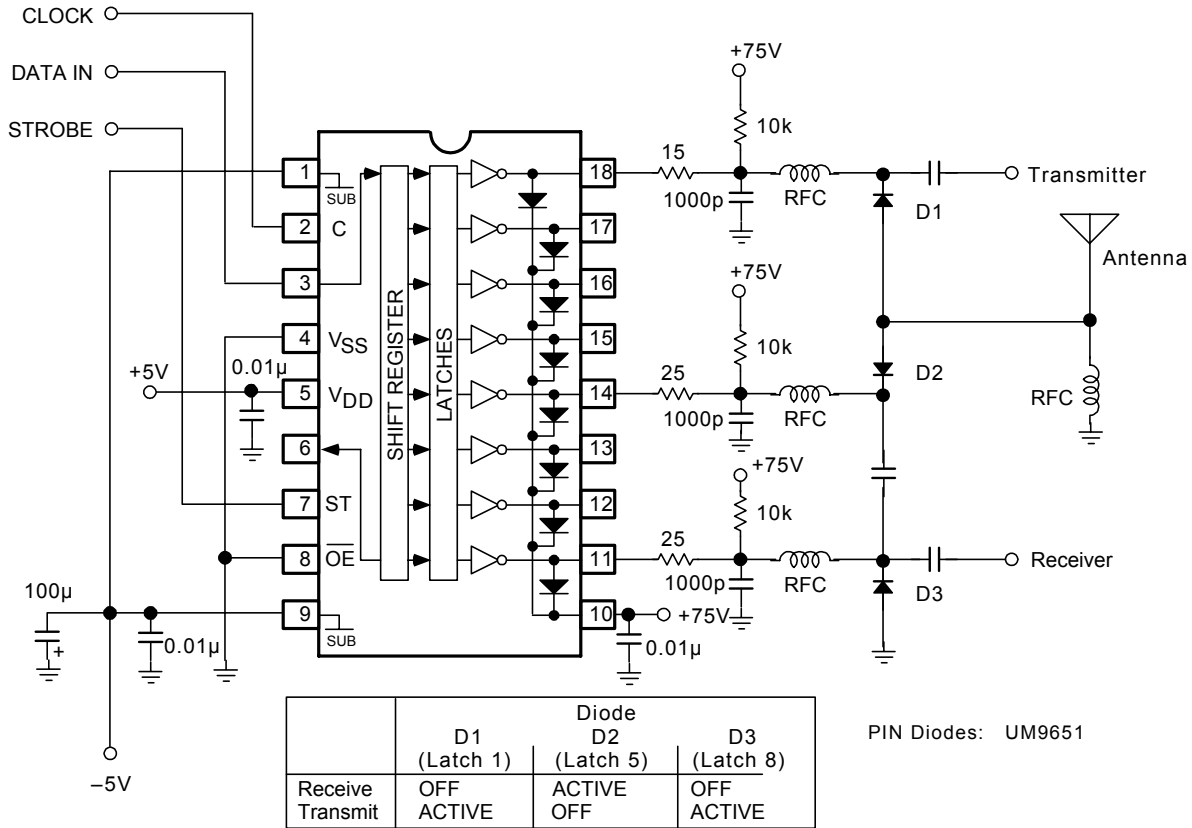

MICREL, INC. 2180 FORTUNE DRIVE SAN JOSE, CA 95131 USA
 TEL +1 (408) 944-0800 FAX +1 (408) 474-1000 WEB <http://www.micrel.com>

The information furnished by Micrel in this data sheet is believed to be accurate and reliable. However, no responsibility is assumed by Micrel for its use. Micrel reserves the right to change circuitry and specifications at any time without notification to the customer.

Micrel Products are not designed or authorized for use as components in life support appliances, devices or systems where malfunction of a product can reasonably be expected to result in personal injury. Life support devices or systems are devices or systems that (a) are intended for surgical implant into the body or (b) support or sustain life, and whose failure to perform can be reasonably expected to result in a significant injury to the user. A Purchaser's use or sale of Micrel Products for use in life support appliances, devices or systems is a Purchaser's own risk and Purchaser agrees to fully indemnify Micrel for any damages resulting from such use or sale.

© 1998 Micrel, Incorporated.

Looking for pricing, stock, or lifecycle information?

Click below to explore more details on WIN SOURCE:

- ⊖ [View MIC5842BWM on WIN SOURCE](#)
- ⊖ [Microchip Technology Information](#)

Optimize Your Supply Chain with WIN SOURCE Solutions

- ✓ Global Sourcing Solution
- ✓ Obsolete Management
- ✓ Cost Control Management
- ✓ Shortage Management
- ✓ Alternative Solution
- ✓ Excess Inventory Management