



**THE DATASHEET OF
MIC4468CWM**





MIC4467/4468/4469

Quad 1.2A-Peak Low-Side MOSFET Driver

Bipolar/CMOS/DMOS

General Description

The MIC4467/8/9 family of 4-output CMOS buffer/drivers is an expansion from the earlier single- and dual-output drivers, to which they are functionally closely related. Because package pin count permitted it, each driver has been equipped with a 2-input logic gate for added flexibility. Placing four high-power drivers in a single package also improves system reliability and reduces total system cost. In some applications, one of these drivers can replace not only two packages of single-input drivers, but some of the associated logic as well.

Although primarily intended for driving power MOSFETs, and similar highly capacitive loads, these drivers are equally well suited to driving any other load (capacitive, resistive, or inductive), which requires a high-efficiency, low-impedance driver capable of high peak currents, rail-to-rail voltage swings, and fast switching times. For example, heavily loaded clock lines, coaxial cables, and piezoelectric transducers can all be driven easily with MIC446X series drivers. The only limitation

Features

- Built using reliable, low power CMOS processes
- Latchproof. Withstands 500mA Inductive Kickback
- 3 Input Logic Choices
- Symmetrical Rise and Fall Times.....25ns
- Short, Equal Delay Times75ns
- High Peak Output Current..... 1.2A
- Wide Operating Range 4.5 to 18V
- Low Equivalent Input Capacitance (typ) 6pF
- Inputs = Logic 1 for Any Input From 2.4V to V_s
- ESD Protected

Applications

- General-Purpose CMOS Logic Buffer
- Driving All 4 MOSFETs in an H-Bridge
- Direct Small-Motor Driver
- Relay or Peripheral Drivers
- Dual Differential Output Power Drivers
- CCD Driver
- Pin-Switching Network Driver

Logic Diagrams

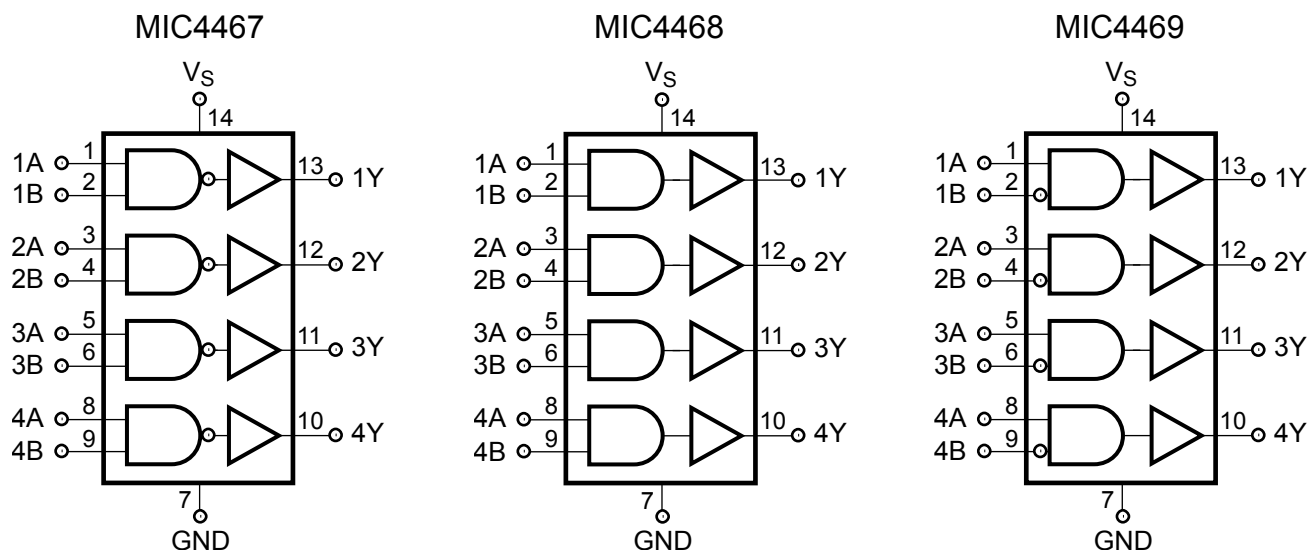

on loading is that total power dissipation in the IC must be kept within the power dissipation limits of the package.

to 5V of noise spiking (either polarity) occurs on the ground line. They can accept up to half an amp of inductive kickback current (either polarity) into their outputs without damage or logic upset.

The MIC446X series drivers are built using a BCD process. They will not latch under any conditions within their power and voltage ratings. They are not subject to damage when up

Ordering Information

Part Number		Temperature Range	Package
Standard	Pb-Free		
MIC44xxCN*	MIC44xxZN*	0°C to +70°C	14-pin Plastic DIP
MIC44xxCWM*	MIC44xxZWM*	0°C to +70°C	16-pin Wide SOIC
MIC44xxBN*	MIC44xxYN*	-40°C to +85°C	14-pin Plastic DIP
MIC44xxBWM*	MIC44xxYWM*	-40°C to +85°C	16-pin Wide SOIC

* xx identifies input logic:

67 — NAND 68 — AND 69 — AND with 1 inverting input

**Pb-Free industrial grade PDIP available in MIC4468 & MIC4469 only.

Truth Table

Part No.	Inputs		Output Y
	A	B	
MIC4467 (Each Driver)	L	X	H
	X	L	H
	H	H	L
MIC4468 (Each Driver)	H	H	H
	L	X	L
	X	L	L
MIC4469 (Each Driver)	L	X	L
	X	H	L
	H	L	H

Pin Configurations

14-Pin DIP (N)

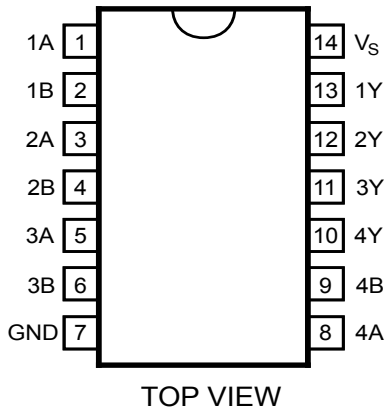

16-Pin Wide SOIC (WM)

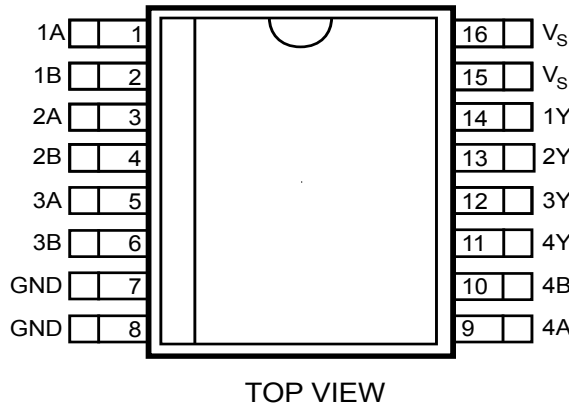

Block Diagrams

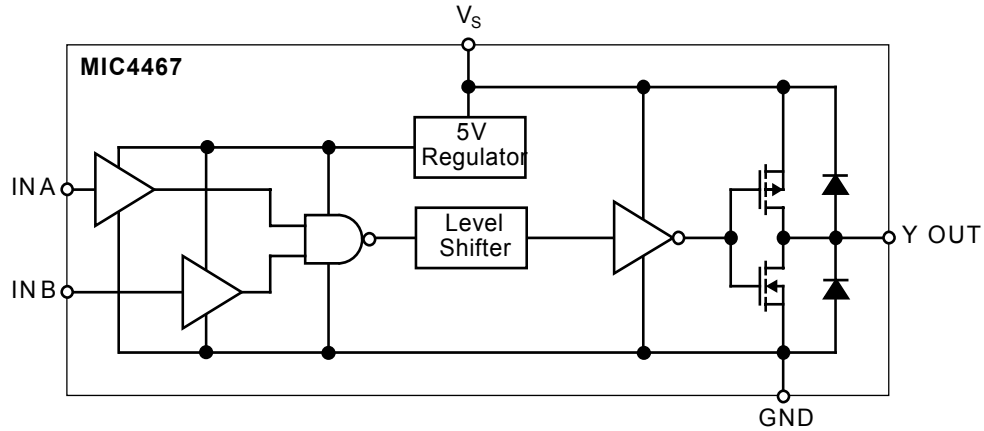

Functional Diagram for One Driver (Four Drivers per Package–Ground Unused Inputs)

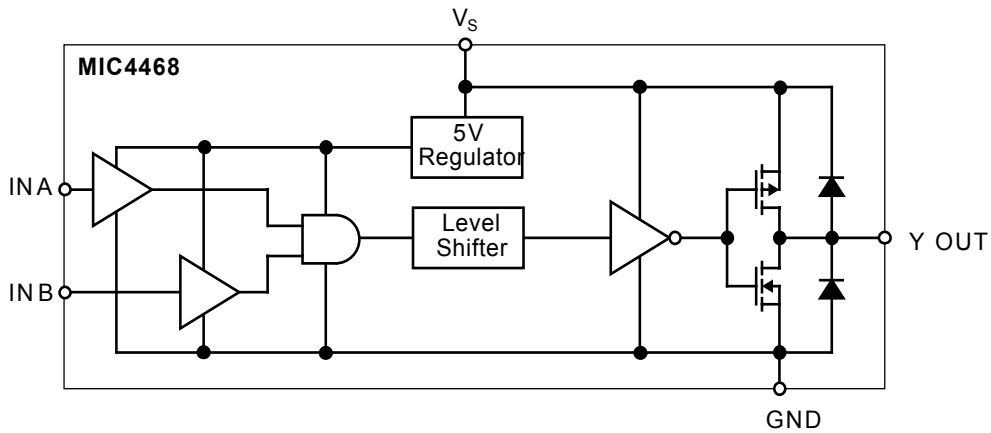

Functional Diagram for One Driver (Four Drivers per Package–Ground Unused Inputs)

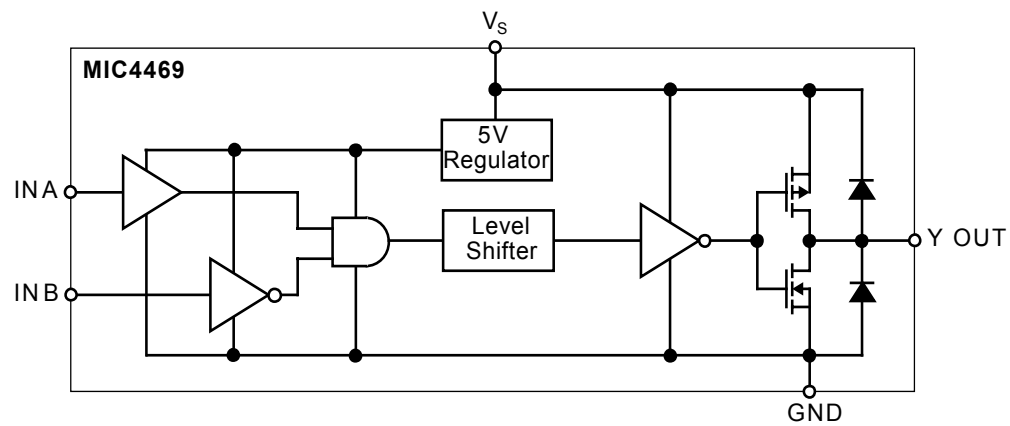

Functional Diagram for One Driver (Four Drivers per Package–Ground Unused Inputs)

Absolute Maximum Ratings (Notes 1 and 2)

Supply Voltage	22V	Power Dissipation	
Input Voltage	(GND – 5V) to ($V_S + 0.3V$)	N Package (14-Pin Plastic DIP)	1.5W
Maximum Chip Temperature		WM Package (16-Pin Wide SOIC)	1W
Operating	150°C	Package Thermal Resistance	
Storage	–65° to +150°C	N Package (14-Pin Plastic DIP) θ_{JA}	80°C/W
Maximum Load Temperature		WM Package (16-Pin Wide SOIC) θ_{JA}	120°C/W
(10 sec, for soldering)	300°C		
Operating Ambient Temperature			
C Version	0° to +70°C		
B Version	–40° to +85°C		

Electrical Characteristics: Measured at $T_A = 25^\circ\text{C}$ with $4.5V \leq V_S \leq 18V$ unless otherwise specified. (Note 3)

Symbol	Parameter	Conditions	Min	Typ	Max	Units
INPUT						
V_{IH}	Logic 1 Input Voltage		2.4	1.3		V
V_{IL}	Logic 0 Input Voltage			1.2	0.8	V
I_{IN}	Input Current	$0 \leq V_{IN} \leq V_S$	–1		1	μA
OUTPUT						
V_{OH}	High Output Voltage	$I_{LOAD} = 10\text{mA}$	$V_S - 0.15$			V
V_{OL}	Low Output Voltage	$I_{LOAD} = 10\text{mA}$			0.15	V
R_O	Output Resistance	$I_{OUT} = 10\text{mA}, V_S = 18V$		5	15	Ω
I_{PK}	Peak Output Current			1.2		A
I	Latch-Up Protection Withstand Reverse Current		>500			mA
SWITCHING TIME						
t_R	Rise Time	Test Figure 1		14	25	ns
t_F	Fall Time	Test Figure 1		13	25	ns
t_{D1}	Delay Time	Test Figure 1		30	75	ns
t_{D2}	Delay Time	Test Figure 1		45	75	ns
POWER SUPPLY						
I_S	Power Supply Current Supply			0.2	4	mA

Note 3. Specification for packaged product only.

Electrical Characteristics:

Measured over operating temperature range with $4.5V \leq V_S \leq 18V$ unless otherwise specified.

Symbol	Parameter	Conditions	Min	Typ	Max	Units
INPUT						
V_{IH}	Logic 1 Input Voltage		2.4	1.4		V
V_{IL}	Logic 0 Input Voltage			1.0	0.8	V
I_{IN}	Input Current	$0 \leq V_{IN} \leq V_S$	-1		1	μA
OUTPUT						
V_{OH}	High Output Voltage	$I_{LOAD} = 10 \text{ mA}$	$V_S - 0.3$			V
V_{OL}	Low Output Voltage	$I_{LOAD} = 10 \text{ mA}$			0.3	V
R_O	Output Resistance	$I_{OUT} = 10 \text{ mA}, V_S = 18V$		7	30	Ω
I_{PK}	Peak Output Current			1.2		A
I	Latch-Up Protection Withstand Reverse Current		500			mA
SWITCHING TIME						
t_R	Rise Time	Test Figure 1		17	50	ns
t_F	Fall Time	Test Figure 1		16	50	ns
t_{D1}	Delay Time	Test Figure 1		35	100	ns
t_{D2}	Delay Time	Test Figure 1		55	100	ns
POWER SUPPLY						
I_S	Power Supply Current Supply			0.4	8	mA

NOTE 1: Functional operation above the absolute maximum stress ratings is not implied.

NOTE 2: Static sensitive device. Store only in conductive containers. Handling personnel and equipment should be grounded to prevent static damage.

Typical Characteristics

Rise and Fall Time vs. Supply Voltage

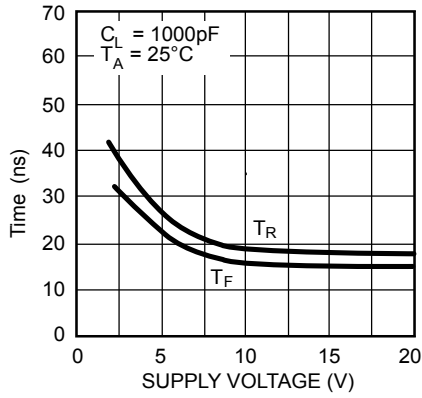

Delay Time vs. Supply Voltage

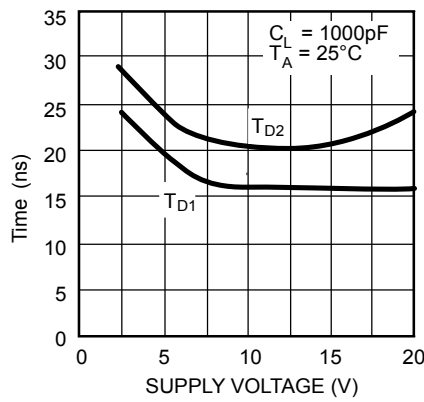

Rise and Fall Time vs. Temperature

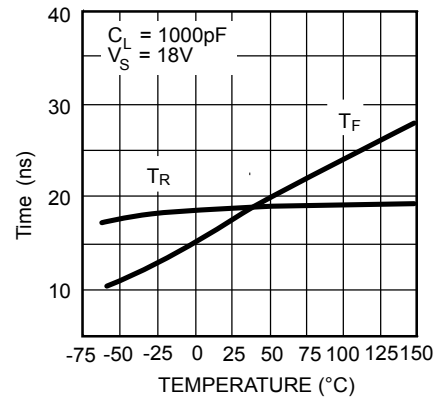

Delay Time vs. Temperature

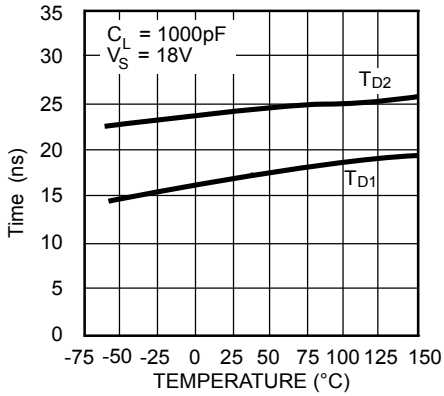

Supply Current vs. Capacitive Load

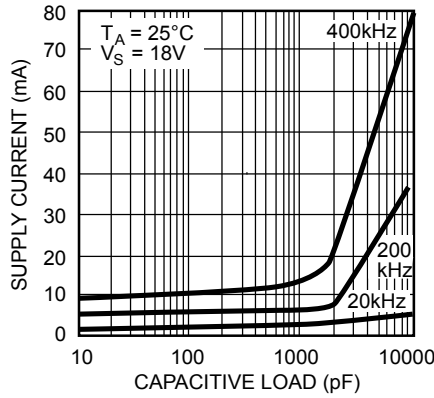

Rise and Fall Time vs. Capacitive Load

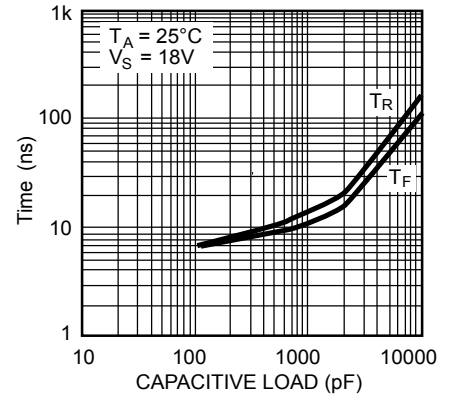

Supply Current vs. Frequency

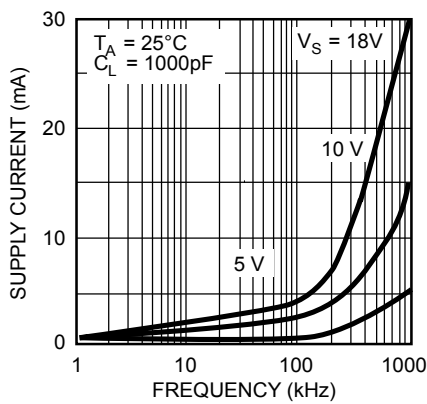

High Output vs. Current

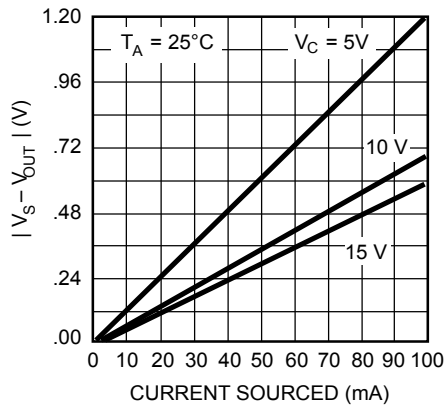

Low Output vs. Current

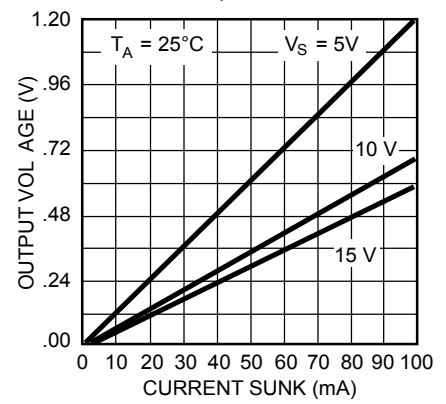

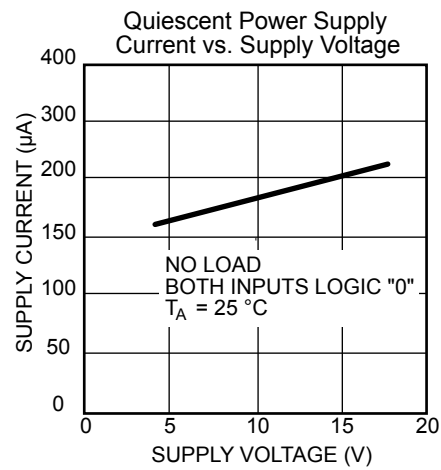
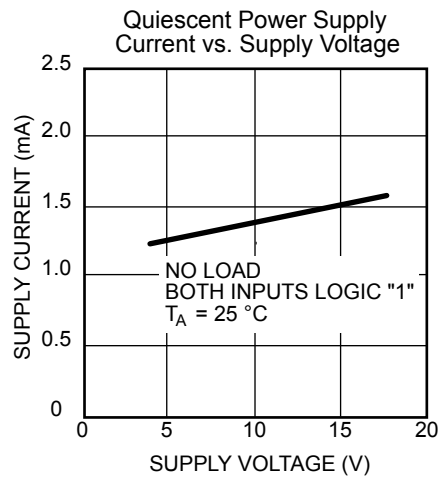

Test Figure 1

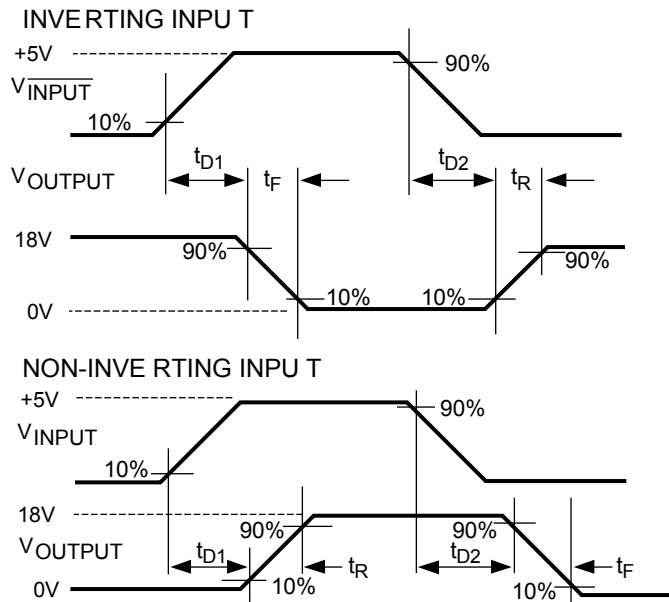
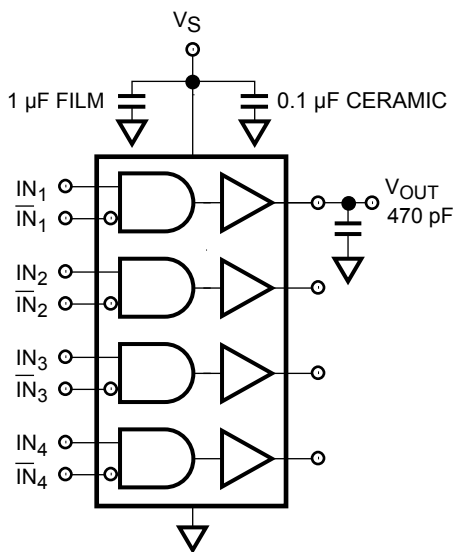

Package Power Dissipation

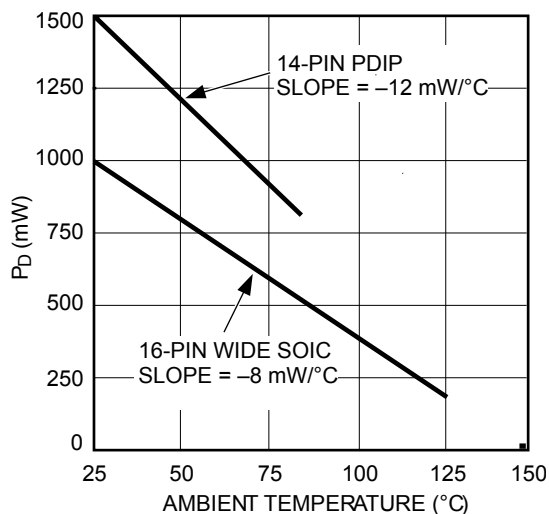

Quad Driver Drives H Bridge to Control Motor Speed and Direction

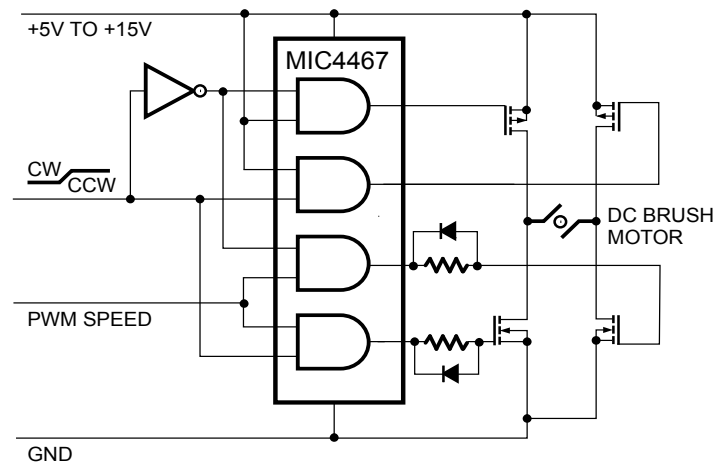

Package Information

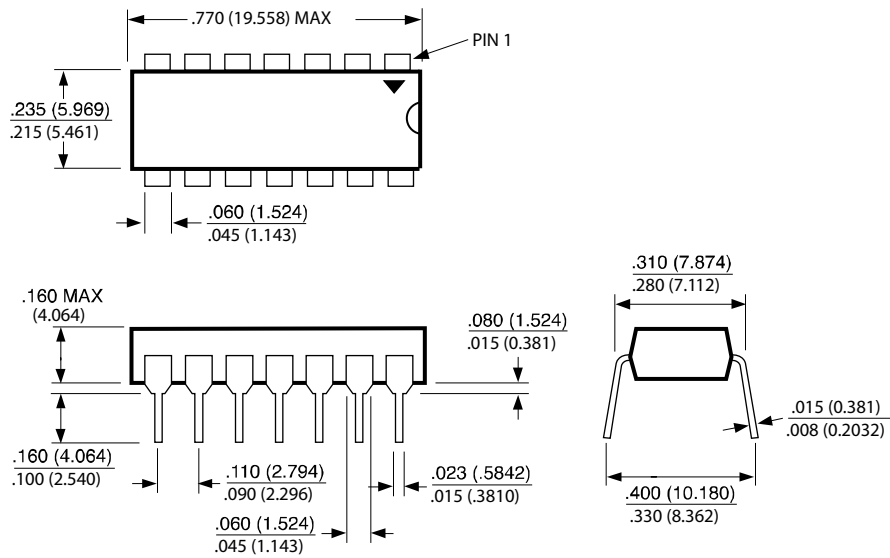

14-Pin Plastic DIP (N)

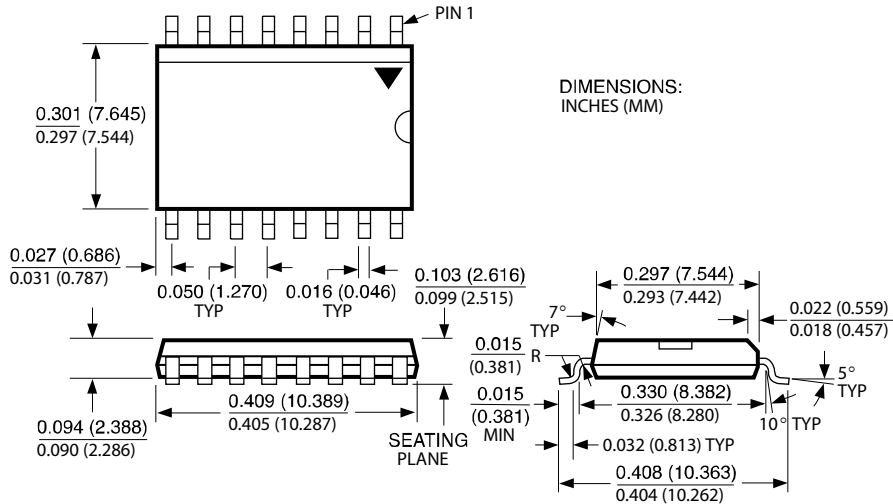

16-Pin Wide SOP (WM)

MICREL INC. 2180 FORTUNE DRIVE SAN JOSE, CA 95131 USA

TEL + 1 (408) 944-0800 FAX + 1 (408) 474-1000 WEB <http://www.micrel.com>

This information furnished by Micrel in this data sheet is believed to be accurate and reliable. However no responsibility is assumed by Micrel for its use. Micrel reserves the right to change circuitry and specifications at any time without notification to the customer.

Micrel Products are not designed or authorized for use as components in life support appliances, devices or systems where malfunction of a product can reasonably be expected to result in personal injury. Life support devices or systems are devices or systems that (a) are intended for surgical implant into the body or (b) support or sustain life, and whose failure to perform can be reasonably expected to result in a significant injury to the user. A Purchaser's use or sale of Micrel Products for use in life support appliances, devices or systems is a Purchaser's own risk and Purchaser agrees to fully indemnify Micrel for any damages resulting from such use or sale.

© 1998 Micrel, Inc.

Looking for pricing, stock, or lifecycle information?

Click below to explore more details on WIN SOURCE:

- ⊖ [View MIC4468CWM on WIN SOURCE](#)
- ⊖ [Microchip Technology Information](#)

Optimize Your Supply Chain with WIN SOURCE Solutions

- ✓ Global Sourcing Solution
- ✓ Obsolete Management
- ✓ Cost Control Management
- ✓ Shortage Management
- ✓ Alternative Solution
- ✓ Excess Inventory Management