



MIC2545A/2549A

Programmable Current-Limit High-Side Switch

General Description

The MIC2545A and MIC2549A are integrated high-side power switches optimized for low-loss DC power switching and other power-management applications, including advanced configuration and power interface (ACPI). The MIC2545A/49A is a cost-effective, highly-integrated solution that requires few external components to satisfy USB and ACPI requirements.

Load current management features include a precision, resistor-programmable output current-limit and a soft-start circuit, which minimizes inrush current when the switch is enabled. Thermal shutdown, along with adjustable current-limit, protects the switch and the attached device.

The MIC2545A/49A's open-drain flag output is used to indicate current-limiting or thermal shutdown to a local controller. The MIC2549A has an additional internal latch which turns the output off upon thermal shutdown, providing robust fault control. The enable signal is compatible with both 3V and 5V logic, and is also used as the thermal shutdown latch reset for the MIC2549A.

The MIC2545A and MIC2549A are available in active-high and active-low enable versions in 8-pin DIP, SOIC, and TSSOP packages.

Data sheets and support documentation can be found on Micrel's web site at: www.micrel.com.

Features

- 2.7V to 5.5V input
- Adjustable current-limit up to 3A
- Reverse current flow blocking
- 90 μ A typical on-state supply current
- 1 μ A typical off-state supply current
- 50m Ω maximum on-resistance
- Open-drain fault flag
- Thermal shutdown
- Thermal-shutdown output latch (MIC2549A)
- 2ms (slow) soft-start turn-on, fast turnoff
- Available with active-high or active-low enable

Applications

- USB power distribution
- PCI Bus Power Switching
- Notebook PC
- ACPI power distribution
- PC card hot swap applications
- Inrush current-limiting

Typical Application

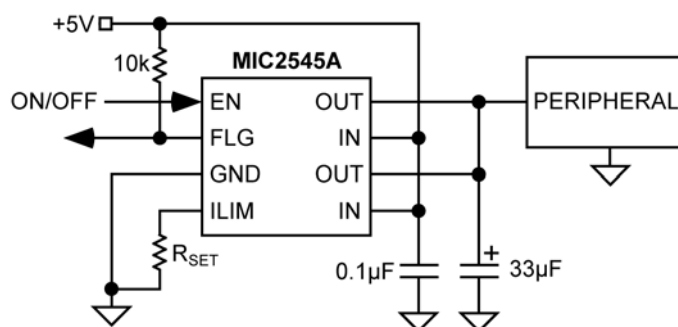

UL Recognized Component

Micrel Inc. • 2180 Fortune Drive • San Jose, CA 95131 • USA • tel +1 (408) 944-0800 • fax + 1 (408) 474-1000 • <http://www.micrel.com>

Ordering Information

Part Number	Enable	Temperature Range	Latch	Pb-Free	Package
MIC2545A-1BM	Active HIGH	-40°C to +85°C	No	No	8-Pin SOP
MIC2545A-1BN	Active HIGH	-40°C to +85°C	No	No	8-Pin DIP
MIC2545A-1BTS	Active HIGH	-40°C to +85°C	No	No	14-Pin TSSOP
MIC2545A-2BM	Active LOW	-40°C to +85°C	No	No	8-Pin SOP
MIC2545A-2BN	Active LOW	-40°C to +85°C	No	No	8-Pin DIP
MIC2545A-2BTS	Active LOW	-40°C to +85°C	No	No	14-Pin TSSOP
MIC2545A-1YM	Active HIGH	-40°C to +85°C	No	Yes	8-Pin SOP
MIC2545A-1YN	Active HIGH	-40°C to +85°C	No	Yes	8-Pin DIP
MIC2545A-1YTS	Active HIGH	-40°C to +85°C	No	Yes	14-Pin TSSOP
MIC2545A-2YM	Active LOW	-40°C to +85°C	No	Yes	8-Pin SOP
MIC2545A-2YN	Active LOW	-40°C to +85°C	No	Yes	8-Pin DIP
MIC2545A-2YTS	Active LOW	-40°C to +85°C	No	Yes	14-Pin TSSOP
MIC2549A-1BM	Active HIGH	-40°C to +85°C	Yes	No	8-Pin SOP
MIC2549A-1BN	Active HIGH	-40°C to +85°C	Yes	No	8-Pin DIP
MIC2549A-1BTS	Active HIGH	-40°C to +85°C	Yes	No	14-Pin TSSOP
MIC2549A-2BM	Active LOW	-40°C to +85°C	Yes	No	8-Pin SOP
MIC2549A-2BN	Active LOW	-40°C to +85°C	Yes	No	8-Pin DIP
MIC2549A-2BTS	Active LOW	-40°C to +85°C	Yes	No	14-Pin TSSOP
MIC2549A-1YM	Active HIGH	-40°C to +85°C	Yes	Yes	8-Pin SOP
MIC2549A-1YN	Active HIGH	-40°C to +85°C	Yes	Yes	8-Pin DIP
MIC2549A-1YTS	Active HIGH	-40°C to +85°C	Yes	Yes	14-Pin TSSOP
MIC2549A-2YM	Active LOW	-40°C to +85°C	Yes	Yes	8-Pin SOP
MIC2549A-2YN	Active LOW	-40°C to +85°C	Yes	Yes	8-Pin DIP
MIC2549A-2YTS	Active LOW	-40°C to +85°C	Yes	Yes	14-Pin TSSOP

Pin Configuration

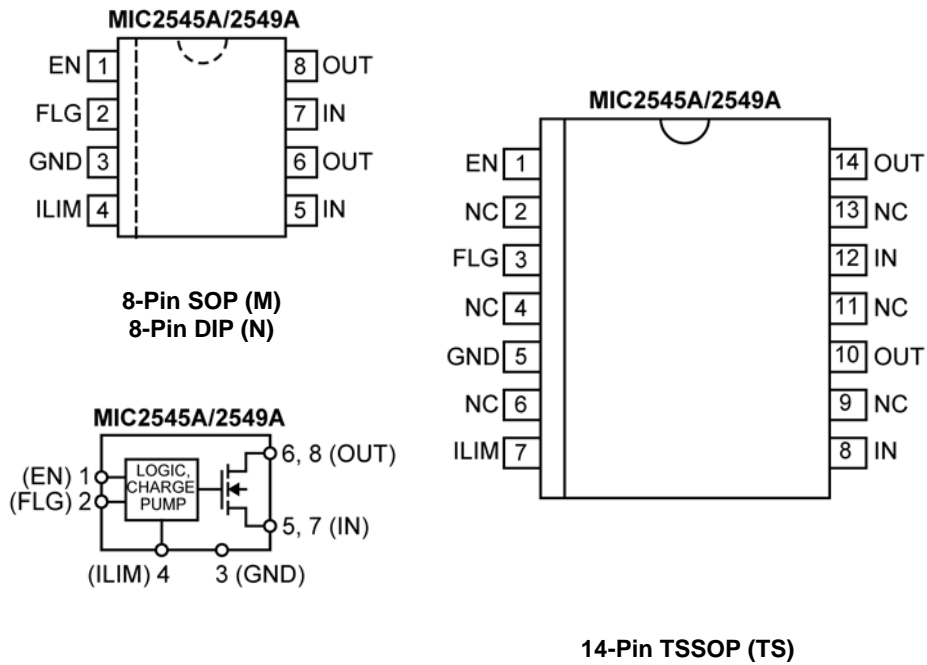

Pin Description

Pin Number SOP, DIP	Pin Number TSSOP	Pin Name	Pin Function
1	1	EN	Enable (Input): Logic-compatible enable input (–1 version is active high, –2 version is active low). High input >1.8V typical; low input <1.4V typical. Do not float. MIC2549A only: Also resets thermal-shutdown latch.
2	3	FLG	Fault Flag (Output): Active-low, open-drain output. Indicates overcurrent or thermal shutdown. MIC2549A only: Latched low on thermal shutdown.
3	5	GND	Ground: supply return.
4	7	ILIM	Current Limit: Sets current-limit threshold using an external resistor (R_{SET}) connected to ground. $76.8\Omega < R_{SET} < 459\Omega$.
5, 7	8, 12	IN	Supply Input: Output MOSFET drain. Also powers internal circuitry. Both IN pins must be externally connected together.
6, 8	10, 14	OUT	Switch Output: Output MOSFET source. Both OUT pins must be externally connected together.
	2, 4, 6, 9, 11, 13	NC	Not internally connected.

Absolute Maximum Ratings⁽¹⁾

Supply Voltage (V_{IN})	+7.0V
Output Voltage (V_{OUT})	+7.0V
Output Current (I_{OUT})	Internally Limited
Enable Input (V_{EN})	-0.3V to +7V
Fault Flag Voltage (V_{FLG})	+7.0V
Fault Flag Current (I_{FLG})	50mA
Storage Temperature (T_s)	-65°C to +150°C
Junction Temperature (T_J)	Internally Limited
Lead Temperature (soldering, 5sec.)	260°C
ESD Rating ⁽³⁾	1500V

Operating Ratings⁽²⁾

Supply Voltage (V_{IN})	+2.7V to +5.5V
Ambient Temperature (T_A)	-40°C to +85°C
Package Thermal Resistance	
PDIP (θ_{JA})	130°C/W
SOIC (θ_{JA})	160°C/W
TSSOP (θ_{JA}) ⁽⁴⁾	100°C/W
Current-Limit Set Range ⁽⁵⁾	0.5A to 3A

Electrical Characteristics⁽⁴⁾

$V_{IN} = +5V$; $T_A = 25^\circ C$, **bold** values indicate -40°C to +85°C, unless noted.

Symbol	Parameter	Condition	Min.	Typ.	Max.	Units
	Supply Current	Switch Off, $V_{OUT} = \text{Open}$ ⁽⁶⁾		0.75	5	μA
		Switch On, $V_{OUT} = \text{Open}$ ⁽⁶⁾		90	125	μA
					150	
V_{EN}	Enable Input Voltage	Enable High Transition ⁽⁶⁾	2.4	1.6		V
		Enable Low Transition ⁽⁶⁾		1.5	0.8	
	Enable Input Current	$V_{EN} = V_{OH(MIN)} = 2.4V$		0.01	1	μA
		$V_{EN} = V_{OL(MAX)} = 0.8V$		0.01	1	
	Enable Input Capacitance	Note 7		1		pF
$R_{DS(ON)}$	Switch Resistance	$I_{OUT} = 500mA$		35	50	m Ω
	Current-Limit Factor	$I_{LIMIT} = 0.5A \text{ to } 3A, V_{OUT} = 1V \text{ to } 4V$ ⁽⁵⁾	184	230	276	V
		$I_{LIMIT} = 1A \text{ to } 2.5A, V_{OUT} = 1V \text{ to } 4V$ ⁽⁵⁾	195	230	264	
	Output Leakage Current	Switch Off, $V_{OUT} = 0V$		1	10	μA
t_{ON}	Output Turn-On Delay	$R_L = 10\Omega, C_L = 1\mu F$, Figures 1a, 1b	1	2	5	ms
t_R	Output Turn-On Rise Time	$R_L = 10\Omega, C_L = 1\mu F$, Figures 1a, 1b	0.75	1.8	4.9	ms
t_{OFF}	Output Turn-Off Delay	$R_L = 10\Omega, C_L = 1\mu F$, Figures 1a, 1b		25		μs

Notes:

- Exceeding the absolute maximum rating may damage the device.
- The device is not guaranteed to function outside its operating rating.
- Devices are ESD sensitive. Handling precautions recommended. Human body model, 1.5k in series with 100pF.
- Assumes 4-layer PCB is used.
- Current limit is determined by $I_{LIMIT} = \frac{230}{R_{SET}}$, where R_{SET} is in Ωs , and 230 is typical current-limit factor in volts.
- Off is $\leq 0.8V$ and on is $\geq 2.4V$ for the MIC2545A-1 and MIC2549A-1. Off is $\geq 2.4V$ and on is $\leq 9.8V$ for the MIC2545A-2 and MIC2549A-2. The enable input has about 100mV of hysteresis.
- Guaranteed by design but not production tested.

Electrical Characteristics⁽⁴⁾ (Continued)

$V_{IN} = +5V$; $T_A = 25^\circ C$, **bold** values indicate $-40^\circ C$ to $+85^\circ C$, unless noted.

Symbol	Parameter	Condition	Min.	Typ.	Max.	Units
t_F	Output Turn-Off Fall Time	$R_L = 10\Omega$, $C_L = 1\mu F$, Figures 1a, 1b		23		μs
	Overtemperature Threshold Shutdown	T_J Increasing		135		$^\circ C$
		T_J Decreasing		120		
	Error Flag Off Current	$V_{FLG} = 5V$		0.01	1	μA
	EN Pulse Reset Width	MIC2549A Thermal-Shutdown Latch ⁽⁷⁾	1			μs
t_{SU}	V_{IN} to EN Set-Up	MIC2549 ⁽⁷⁾ , Figure 1c	0			μs
	Current-Limit Response Time	$V_{OUT} = 0V$ to $I_{OUT} = 2A$, $I_{SET} = 1A$ ⁽⁷⁾		40		μs
V_{OL}	Error Flag Output Resistance	$I_{FLG} = 10mA$		4	15	Ω

Test Circuit

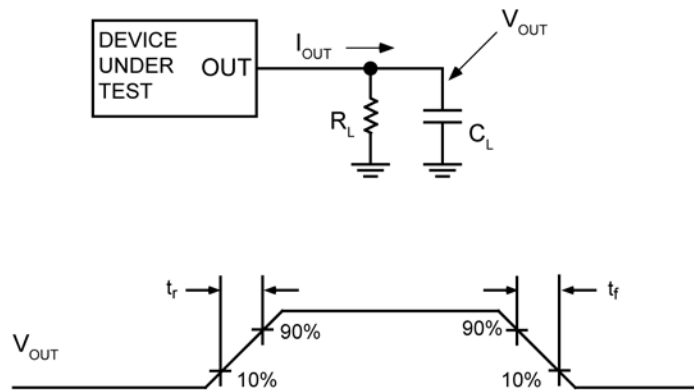

Functional Characteristics Test Circuit

Timing Diagrams

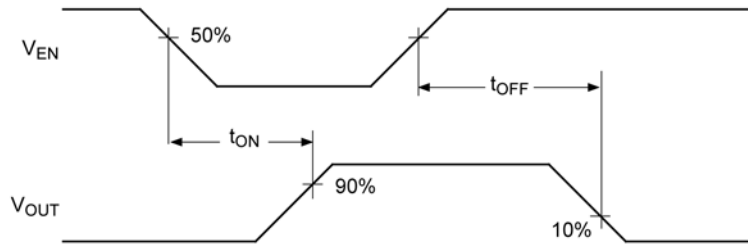

Figure 1a. MIC2545A/49A-2

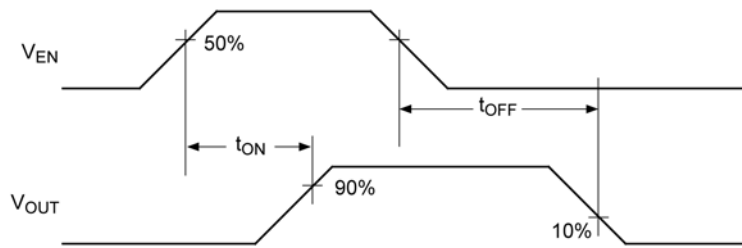

Figure 1b. MIC2545A/49A-1

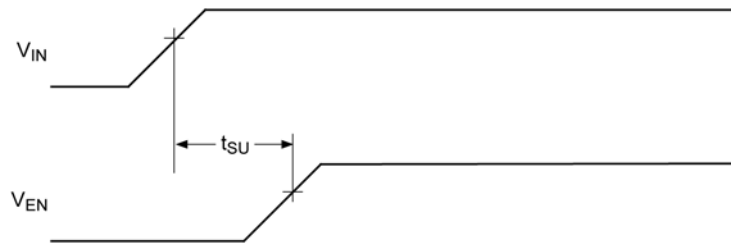

Figure 1c. Input-to-Enable Setup Timing

Timing Diagrams (Continued)

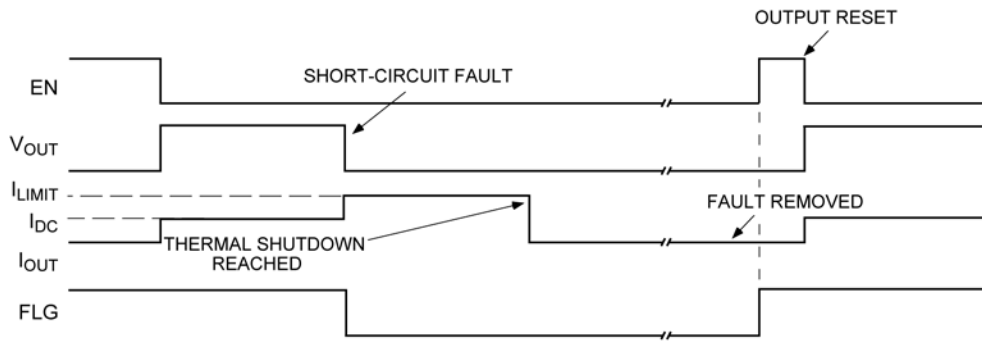

Figure 2a. MIC2545A-2 Timing: Output is Reset by Toggling EN

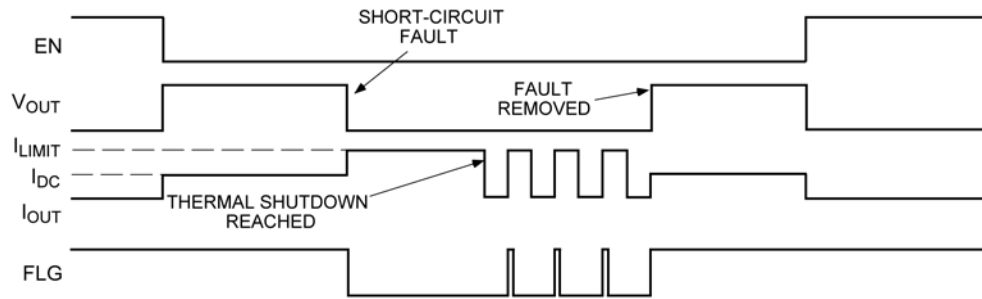
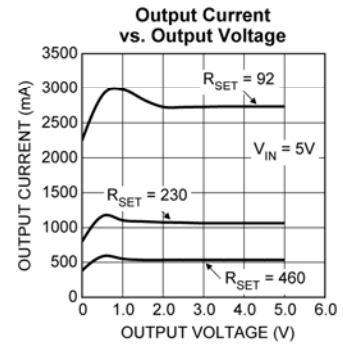
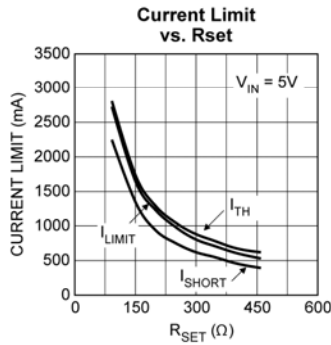
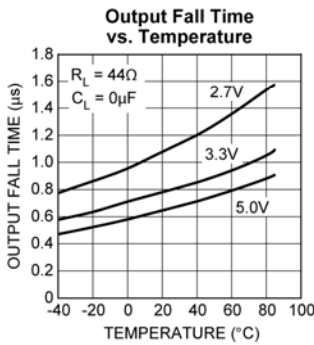
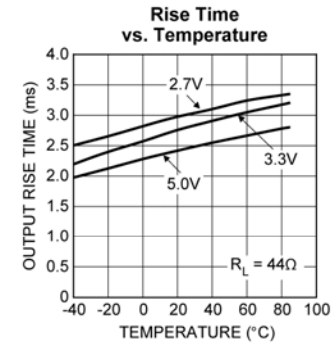
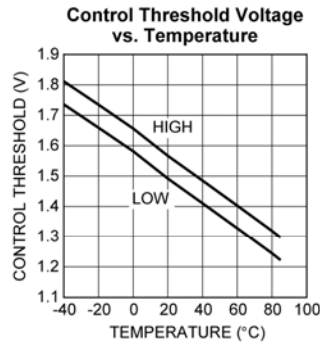
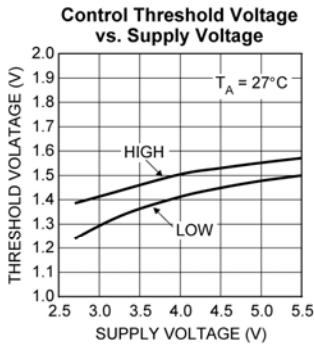
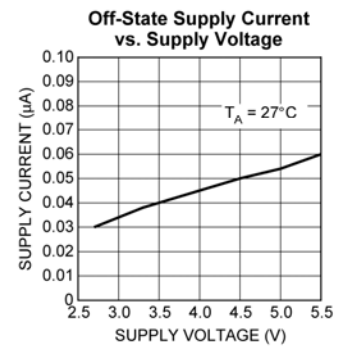
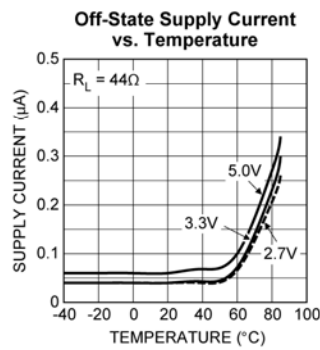
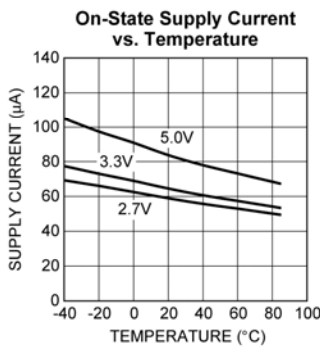
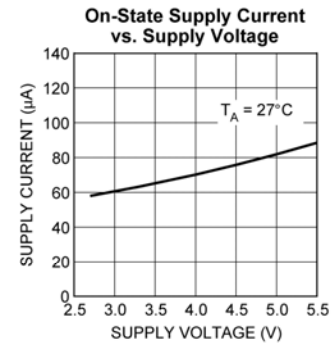
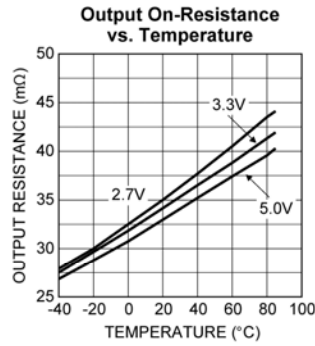
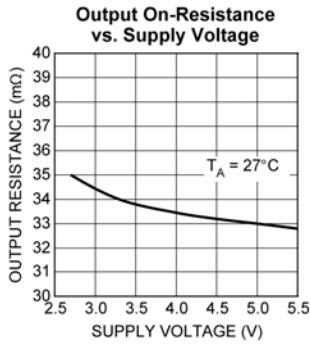
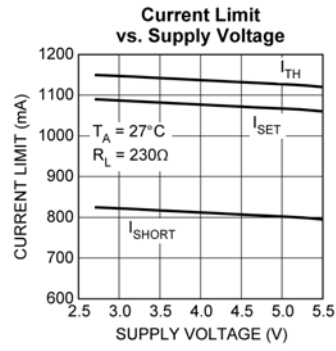
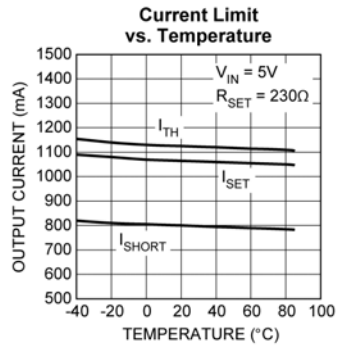

Figure 2b. MIC2545A-2 Timing

Typical Characteristics



Typical Characteristics (Continued)



Functional Characteristics

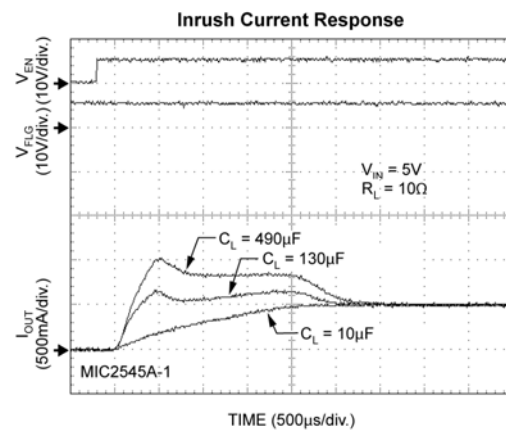
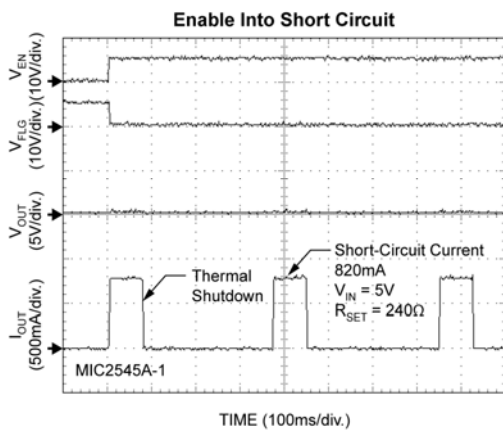
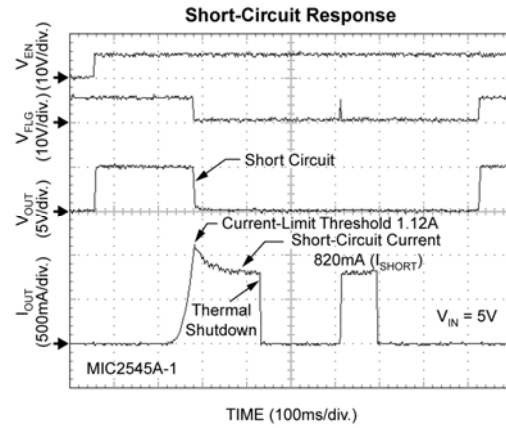
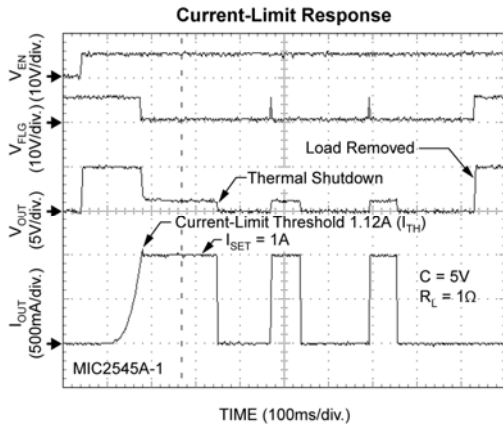
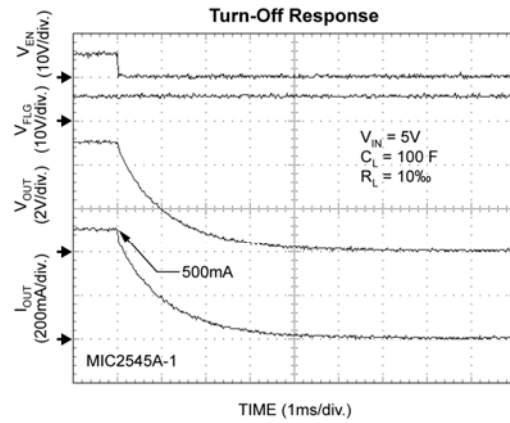
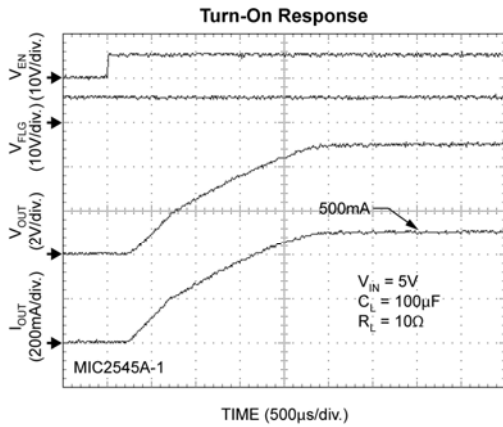

Functional Characteristics (Continued)

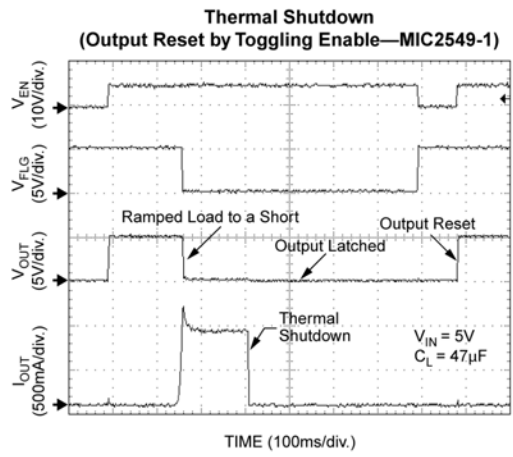

Block Diagram

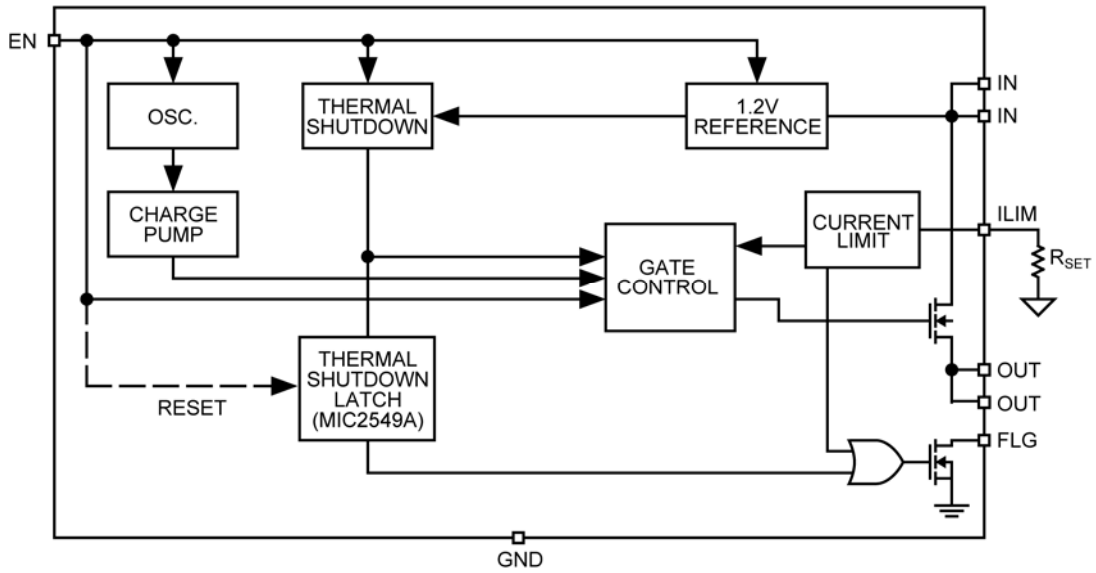

Functional Description

The MIC2545A and MIC2549A are high-side N-channel switches available with active-high or active-low enable inputs. Fault conditions turn off or inhibit turn-on of the output transistor and activate the open-drain error flag transistor making it sink current to ground.

Input and Output

IN is the power supply connection to the logic circuitry and the drain of the output MOSFET. OUT is the source of the output MOSFET. In a typical circuit, current flows from IN to OUT toward the load. If V_{OUT} is greater than V_{IN} , current will flow from OUT to IN since the switch is bidirectional when enabled. The output MOSFET and driver circuitry are also designed to allow the MOSFET source to be externally forced to a higher voltage than the drain ($V_{OUT} > V_{IN}$) when the switch is disabled. In this situation, the MIC2545A/49A avoids undesirable current flow from OUT to IN. Both IN pins must be connected together, and both OUT pins must be connected together.

Thermal Shutdown

Thermal shutdown shuts off the output MOSFET and signals the fault flag if the die temperature exceeds 135°C. 10°C of hysteresis prevents the switch from turning on until the die temperature drops to 125°C. Overtemperature detection functions only when the switch is enabled.

The MIC2549A features an internal latch which causes the part to remain off after thermal shutdown until a reset pulse is provided via the enable pin (pin1). While in current-limit, the thermal shutdown latch prevents on/off cycling of the output. Refer to Figure 2 for timing diagram. The flag remains low until reset.

Enable Input

EN must be driven logic high or logic low, or be pulled high or low for a clearly defined input. Floating the input may cause unpredictable operation. EN should not be allowed to go negative with respect to GND.

Current-Limit Operation

The current limit is user adjustable with an external set resistor. Current limiting in the range of 500mA to 3A is available with a set point accuracy of better than ±30% (±20% for I_{SET} 1 to 2.5A). The current-limit circuit prevents damage to the output MOSFET and external load.

The current-limit response of the MIC2545A/49A is based on the type of load that is applied to the output and is defined in three parts:

1. The first mode of operation is where the device enters a constant-current mode preventing further increases in output current. The value of this current, I_{LIMIT} , is defined by the value of R_{SET} as explained further in this section.
2. When a short circuit is applied to the output of an enabled device the output current immediately folds back to a value less than I_{LIMIT} called I_{SHORT} . This further protects the load and reduces device power dissipation. Refer to the “Typical Characteristics: Output Current vs. Output Voltage” graph for details.
3. When a load is increased, the output current will proportionally increase up to the current-limit threshold, I_{TH} , as shown in the “Functional Characteristics: Current-Limit Response” graph. The device in this case will supply current slightly higher than the current-limit set point defined by R_{SET} . As the load is increased further the current folds back to I_{LIMIT} .

The nominal current-limit value, I_{LIMIT} , is set with an external resistor between I_{LIM} (Pin 4) and GND (Pin 3). For a desired current-limit, the value of the external set resistor is given by:

$$R_{SET} = \left(\frac{230}{I_{LIMIT}} \right)$$

where:

$$76.8\Omega < R_{SET} < 459\Omega$$

Refer to the “Typical Characteristics: Current-Limit vs R_{SET} ” graph for more details.

Current through R_{SET} increases with output current. The voltage across R_{SET} could be monitored with a high-impedance comparator to provide an indication of output current. R_{SET} should be between 76.8Ω and 459Ω (1% resistor value).

Fault Flag

FLG is an N-channel, open-drain MOSFET output. The fault-flag is active (low) for current-limit or thermal shutdown conditions. The flag output MOSFET is capable of sinking a 10mA load to typically 100mV above ground. For applications with $V_{IN} = 3.6V$, it is recommended that flag current be limited to 5mA or less.

Application Information

Supply Filtering

A 0.1 μ F to 1 μ F bypass capacitor from IN to GND, located near the MIC2545A and MIC2549A, is strongly recommended to control supply transients. Without a bypass capacitor, an output short may cause sufficient ringing on the input (from supply lead inductance) to damage internal control circuitry.

Input transients must not exceed the absolute maximum supply voltage (V_{IN} (max) = 6V) even for a short duration.

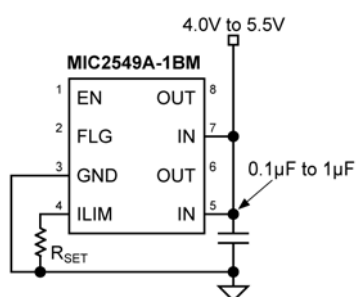

Figure 3. Supply Bypassing

Power Dissipation

The device's junction temperature depends on several factors such as the load, PCB layout, ambient temperature, and package type. Equations that can be used to calculate power dissipation and junction temperature are found below.

Calculation of power dissipation can be accomplished by the following equation:

$$P_D = R_{DS(ON)} \times (I_{OUT})^2$$

To relate this to junction temperature, the following equation can be used:

$$T_J = P_D \times \theta_{JA} + T_A$$

where:

T_J = Junction temperature

T_A = Ambient temperature

θ_{JA} = The thermal resistance of the package

Transient Overcurrent Filter

The inrush current from the connection of a heavy capacitive load may cause the fault flag to fall for 10 μ s to 200 μ s while the switch is in a constant-current mode, charging the capacitance. Adding an optional series resistor-capacitor (R_{SET2}) in parallel with RSET, as shown in Figure 4, allows the transient current-limit to be set to a different value than steady state. A typical USB hot-plug inrush is 2A to 3A for 10 μ s to 20 μ s. If R_{SET} is 435 Ω (530mA), an R_{SET2} of 88 Ω (2.5A) and C_{SET} of 1 μ F ($RC \approx 90\mu$ s) allows transient surge of 3A to pass for 90 μ s without tripping the overcurrent flag (FLG).

USB Power Dissipations

The MIC2545A is ideal for meeting USB power distribution requirements. Figure 7 depicts a USB Host application. R_{SET} should be set to a value providing a current-limit >500mA. The accurate current-limit of the MIC2545A will reduce power supply current requirements. Also, fast reaction to short-circuit faults prevent voltage droop in mobile PC applications.

Printed Circuit Board Hot-Plug

The MIC2545A/49A is an ideal inrush current-limiter suitable for hot-plug applications. Due to the integrated charge pump, the MIC2545A/49A presents a high impedance when off and slowly becomes a low impedance as it turns on. This "soft start" feature effectively isolates power supplies from highly-capacitive loads by reducing inrush current during hot-plug events. Figure 5 shows how the MIC2545A may be used in a hot-plug application.

Package Information

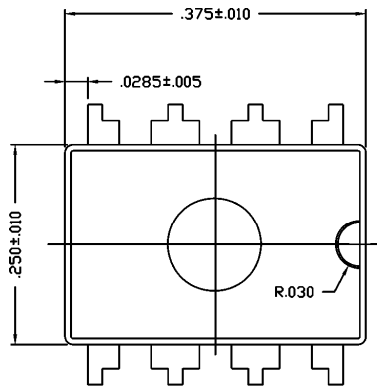

TOP VIEW

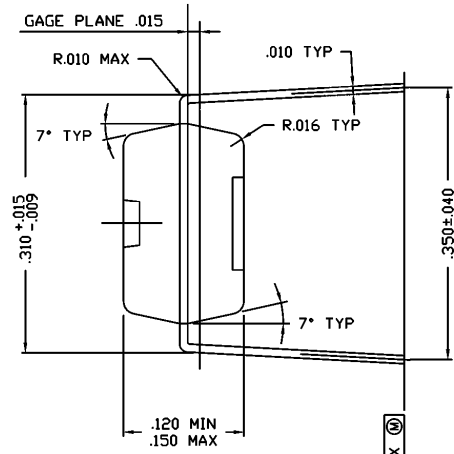

END VIEW

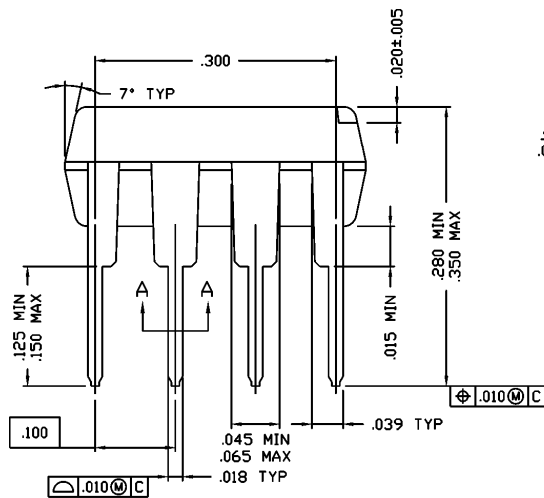

SIDE VIEW

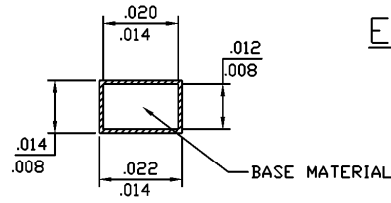

SECTION A-A

8-Pin DIP (N)

Package Information (Continued)

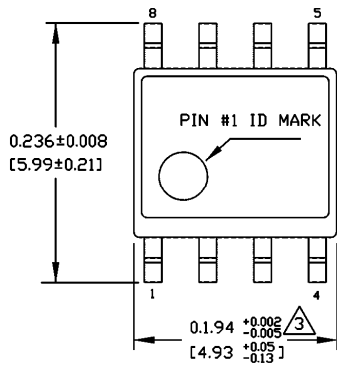

TOP VIEW

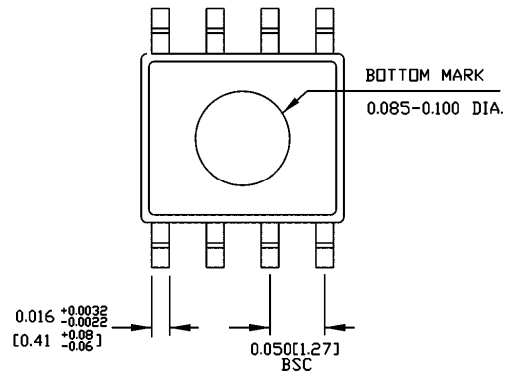

BOTTOM VIEW

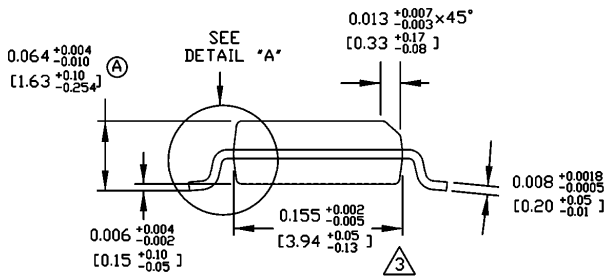

END VIEW

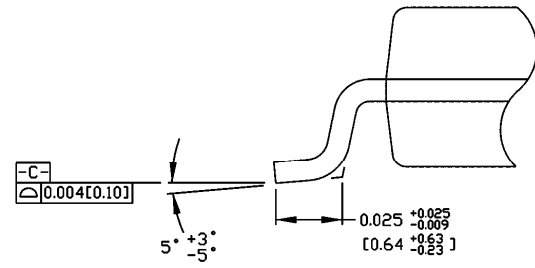

DETAIL "A"

8-Pin SOIC (M)

Package Information (Continued)

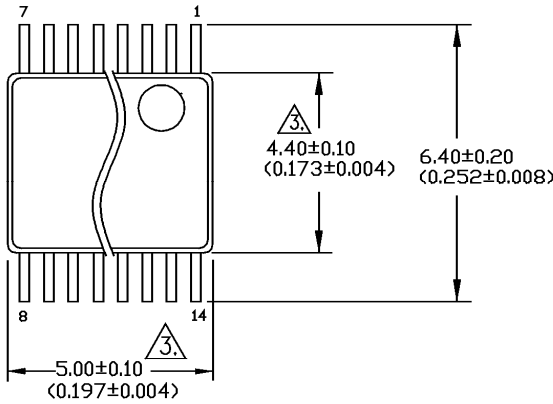

TOP VIEW

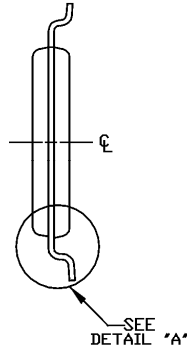

END VIEW

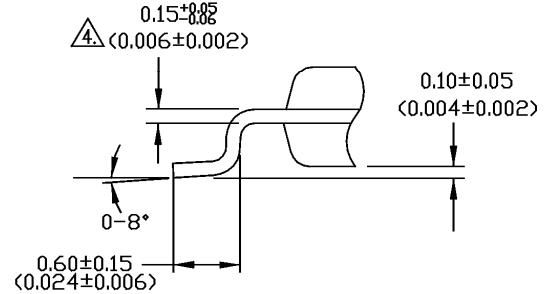

DETAIL 'A'
(VIEW ROTATED 90° C.W.)

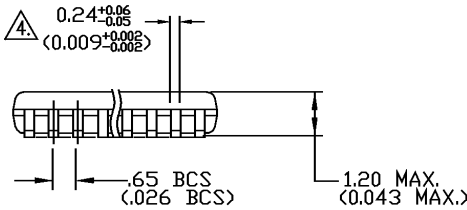

SIDE VIEW

14-Pin TSSOP (TS)

MICREL, INC. 2180 FORTUNE DRIVE SAN JOSE, CA 95131 USA
 TEL +1 (408) 944-0800 FAX +1 (408) 474-1000 WEB <http://www.micrel.com>

Micrel makes no representations or warranties with respect to the accuracy or completeness of the information furnished in this data sheet. This information is not intended as a warranty and Micrel does not assume responsibility for its use. Micrel reserves the right to change circuitry, specifications and descriptions at any time without notice. No license, whether express, implied, arising by estoppel or otherwise, to any intellectual property rights is granted by this document. Except as provided in Micrel's terms and conditions of sale for such products, Micrel assumes no liability whatsoever, and Micrel disclaims any express or implied warranty relating to the sale and/or use of Micrel products including liability or warranties relating to fitness for a particular purpose, merchantability, or infringement of any patent, copyright or other intellectual property right.

Micrel Products are not designed or authorized for use as components in life support appliances, devices or systems where malfunction of a product can reasonably be expected to result in personal injury. Life support devices or systems are devices or systems that (a) are intended for surgical implant into the body or (b) support or sustain life, and whose failure to perform can be reasonably expected to result in a significant injury to the user. A Purchaser's use or sale of Micrel Products for use in life support appliances, devices or systems is a Purchaser's own risk and Purchaser agrees to fully indemnify Micrel for any damages resulting from such use or sale.

© 2004 Micrel, Incorporated.

Looking for pricing, stock, or lifecycle information?

Click below to explore more details on WIN SOURCE:

-  [View MIC2545A-1YM on WIN SOURCE](#)
-  [Microchip Technology](#) Information

Optimize Your Supply Chain with WIN SOURCE Solutions

-  Global Sourcing Solution
-  Obsolete Management
-  Cost Control Management
-  Shortage Management
-  Alternative Solution
-  Excess Inventory Management