

Single-Channel Power Distribution Switch

Features

- 140 mΩ Maximum On-Resistance
- 2.7V to 5.5V Operating Range
- 500 mA Minimum Continuous Output Current
- Short-Circuit Protection with Thermal Shutdown
- Fault Status Flag with 3 ms Filter Eliminates False Assertions
- Undervoltage Lockout
- Reverse Current Flow Blocking (No “Body Diode”)
- Circuit Breaker Mode (MIC2075) Reduces Power Consumption
- Logic-Compatible Input
- Soft-Start Circuit
- Low Quiescent Current
- Pin Compatible with MIC2525
- UL File #E179633

Applications

- USB Peripherals
- General Purpose Power Switching
- ACPI Power Distribution
- Notebook PCs
- PDAs
- PC Card Hot Swap

General Description

The MIC2025 and MIC2075 are high-side MOSFET switches optimized for general-purpose power distribution requiring circuit protection.

The MIC2025/75 are internally current limited and have thermal shutdown that protects the device and load. The MIC2075 offers “smart” thermal shutdown that reduces current consumption in fault modes. When a thermal shutdown fault occurs, the output is latched off until the faulty load is removed. Removing the load or toggling the enable input will reset the device output.

Both devices employ soft-start circuitry that minimizes inrush current in applications where highly capacitive loads are employed. A fault status output flag is provided that is asserted during overcurrent and thermal shutdown conditions.

The MIC2025/75 are available in the 8-Pin MSOP and 8-Pin SOIC packages.

Package Type

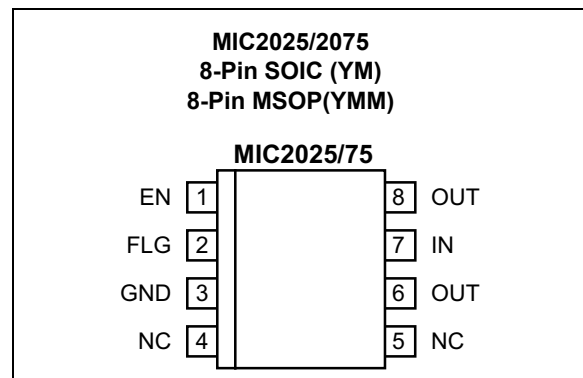

MIC2025/2075

Functional Block Diagram

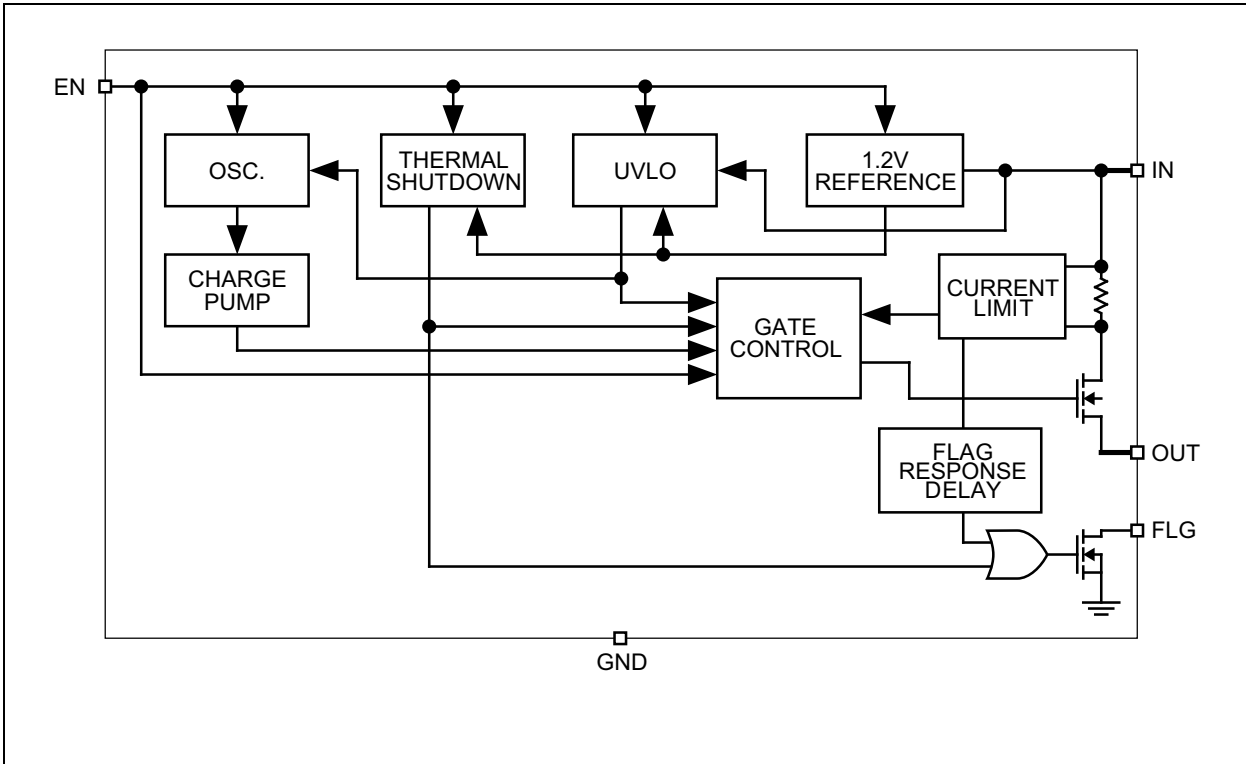

Typical Application Circuit

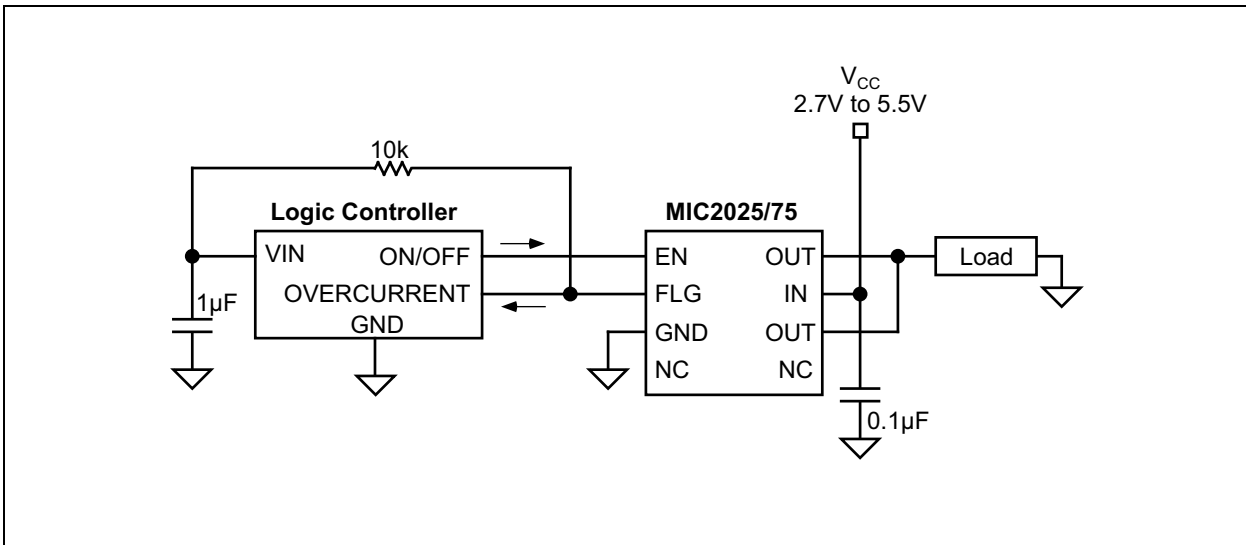

1.0 ELECTRICAL CHARACTERISTICS

Absolute Maximum Ratings †

Supply Voltage (V_{IN})	-0.3V to +6V
Fault Flag Voltage (V_{FLG})	+6V
Fault Flag Current (I_{FLG})	25 mA
Output Voltage (V_{OUT})	+6V
Output Current (I_{OUT})	Internally Limited
Enable Input (I_{EN})	-0.3V to $V_{IN} + 3V$
ESD Rating	(Note 1)

Operating Ratings ‡

Supply Voltage (V_{IN})	+2.7V to +5.5V
-----------------------------	----------------

† **Notice:** Stresses above those listed under “Absolute Maximum Ratings” may cause permanent damage to the device. This is a stress rating only and functional operation of the device at those or any other conditions above those indicated in the operational sections of this specification is not intended. Exposure to maximum rating conditions for extended periods may affect device reliability. Specifications are for packaged product only.

‡ **Notice:** The device is not guaranteed to function outside its operating ratings.

Note 1: Devices are ESD sensitive. Handling precautions are recommended.

TABLE 1-1: ELECTRICAL CHARACTERISTICS

Electrical Characteristics: $V_{IN} = +5V$; $T_A = +25^\circ C$, **Bold** values indicate $-40^\circ C \leq T_A \leq +85^\circ C$; unless otherwise specified.

Parameter	Symbol	Min.	Typ.	Max.	Units	Conditions
Supply Current	I_{DD}	—	0.75	5	μA	MIC20x5-1, $V_{EN} \leq 0.8V$ (switch off), OUT = open
		—	0.75	5	μA	MIC20x5-2, $V_{EN} \geq 2.4V$ (switch off), OUT = open
		—	—	160	μA	MIC20x5-1, $V_{EN} \geq 2.4V$ (switch on), OUT = open
		—	—	160	μA	MIC20x5-2, $V_{EN} \leq 0.8V$ (switch on), OUT = open
Enable Input Voltage	V_{EN}	—	2.1	2.4	V	Low-to-High Transition
		0.8	1.9	—	V	High-to-Low Transition
Enable Input Hysteresis		—	200	—	mV	—
Enable Input Current	I_{EN}	-1	0.01	1	μA	$V_{EN} = 0V$ to 5.5V
Control Input Capacitance	—	—	1	—	pF	—
Switch Resistance	$R_{DS(ON)}$	—	90	140	m Ω	$V_{IN} = 5V$, $I_{OUT} = 500$ mA
		—	100	160	m Ω	$V_{IN} = 3.3V$, $I_{OUT} = 500$ mA
Output Leakage Current	—	—	—	10	μA	MIC2025/2075 (output off)
OFF Current in Latched Thermal Shutdown	—	—	50	—	μA	MIC2075 (during thermal shutdown state)
Output Turn-On Delay	t_{ON}	1	2.5	6	ms	$R_L = 10\Omega$, $C_L = 1 \mu F$, (see Timing Diagrams)
Output Turn-On Rise Time	t_R	0.5	2.3	5.9	ms	$R_L = 10\Omega$, $C_L = 1 \mu F$, (see Timing Diagrams)
Output Turn-Off Delay	t_{OFF}	—	50	100	μs	$R_L = 10\Omega$, $C_L = 1 \mu F$, (see Timing Diagrams)

MIC2025/2075

Electrical Characteristics: $V_{IN} = +5V$; $T_A = +25^{\circ}C$, **Bold** values indicate $-40^{\circ}C \leq T_A \leq +85^{\circ}C$; unless otherwise specified.

Parameter	Symbol	Min.	Typ.	Max.	Units	Conditions
Output Turn-Off Fall Time	t_F	—	50	100	μs	$R_L = 10\Omega$, $C_L = 1 \mu F$. (see Timing Diagrams)
Short-Circuit Output Current	I_{LIMIT}	0.5	0.7	1.25	A	$V_{OUT} = 0V$, enabled into short-circuit
Current-Limit Threshold (See Figure 2-22)	—	0.60	0.85	1.25	A	Ramped load applied to output
Short-Circuit Response Time	—	—	24	—	μs	$V_{OUT} = 0V$ to $I_{OUT} = I_{LIMIT}$ (short applied to output)
Overcurrent Flag Response Delay	t_D	1.5	3	7	ms	$V_{IN} = 5V$, apply $V_{OUT} = 0V$ until FLG low
		1.5	3	8	ms	$V_{IN} = 3.3V$, apply $V_{OUT} = 0V$ until FLG low
Undervoltage Lockout Threshold		2.2	2.5	2.7	V	V_{IN} Rising
		2.0	2.3	2.5	V	V_{IN} Falling
Error Flag Output Resistance		—	8	25	Ω	$I_L = 10 \text{ mA}$, $V_{IN} = 5V$
		—	11	40	Ω	$I_L = 10 \text{ mA}$, $V_{IN} = 3.3V$
Error Flag Off Current		—	—	10	μA	$V_{FLAG} = 5V$
Overtemperature Threshold		—	140	—	$^{\circ}C$	T_J increasing
		—	120	—	$^{\circ}C$	T_J decreasing

TEMPERATURE SPECIFICATIONS (Note 1)

Parameters	Sym.	Min.	Typ.	Max.	Units	Conditions
Temperature Ranges						
Storage Temperature Range	T_S	-65	—	+150	°C	—
Ambient Temperature Range	T_A	-40	—	+85	°C	—
Junction Temperature Range	T_J	—	—	—	°C	Internally Limited
Package Thermal Resistances						
Thermal Resistance SOIC 8-LD	θ_{JA}	—	160	—	°C/W	—
Thermal Resistance MSOP 8-LD	θ_{JA}	—	206	—	°C/W	—

Note 1: The maximum allowable power dissipation is a function of ambient temperature, the maximum allowable junction temperature and the thermal resistance from junction to air (i.e., T_A , T_J , θ_{JA}).

Test Circuit

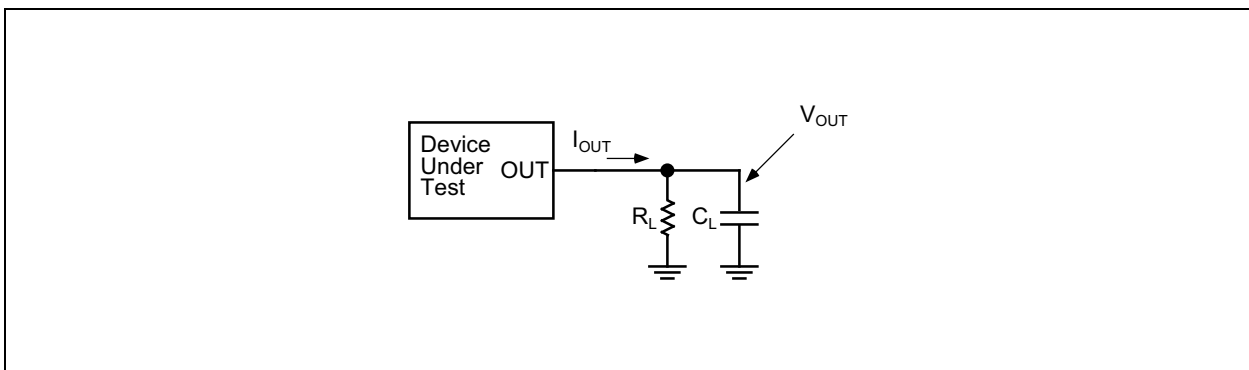

FIGURE 1-1: MIC2025/2075 Test Circuit.

MIC2025/2075

Timing Diagrams

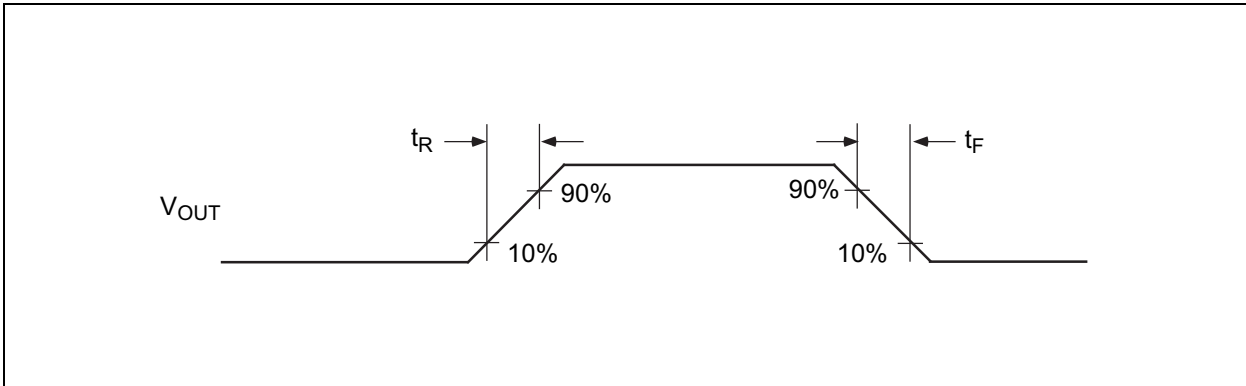

FIGURE 1-2: Output Rise and Fall Times.

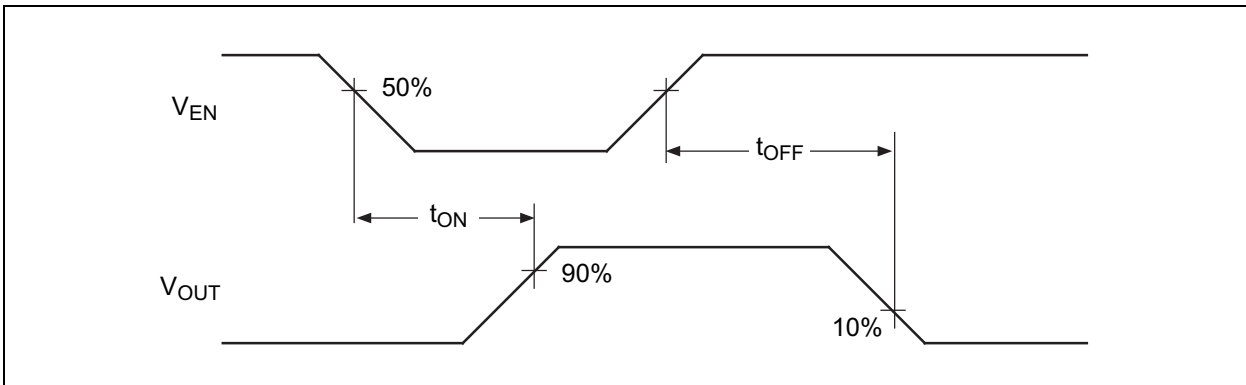

FIGURE 1-3: Active-Low Switch Delay Time (MIC20x5-2).

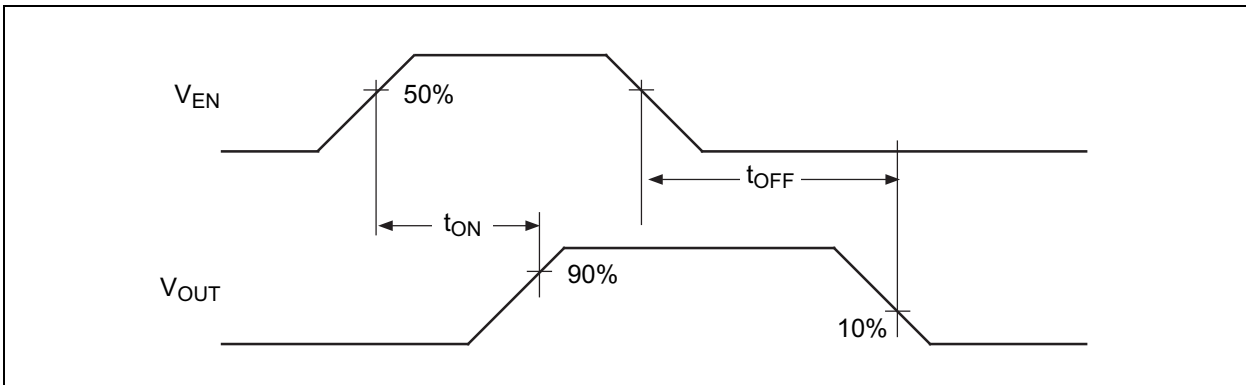

FIGURE 1-4: Active-High Switch Delay Times (MIC20x5-1).

2.0 TYPICAL PERFORMANCE CURVES

Note: The graphs and tables provided following this note are a statistical summary based on a limited number of samples and are provided for informational purposes only. The performance characteristics listed herein are not tested or guaranteed. In some graphs or tables, the data presented may be outside the specified operating range (e.g., outside specified power supply range) and therefore outside the warranted range.

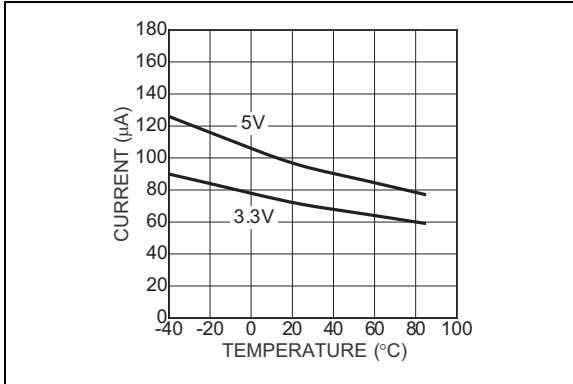

FIGURE 2-1: Supply On-Current vs. Temperature.

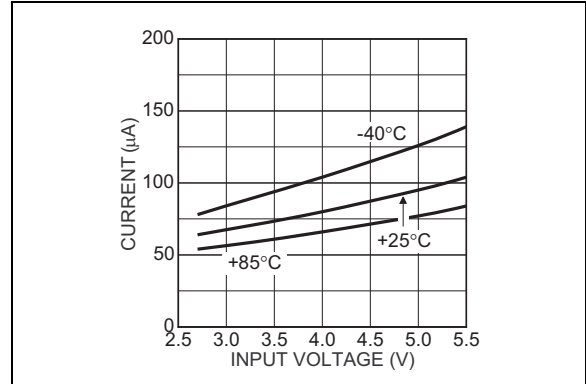

FIGURE 2-4: Supply On-Current vs. Input Voltage.

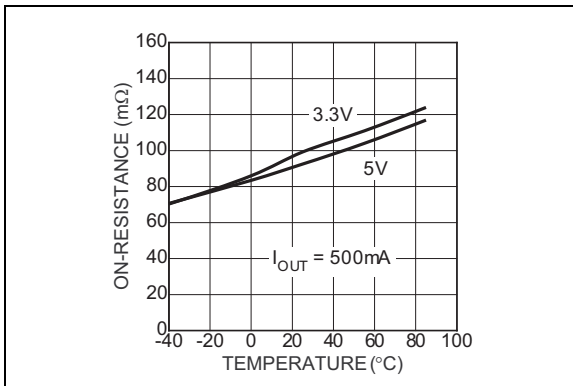

FIGURE 2-2: On-Resistance vs. Temperature.

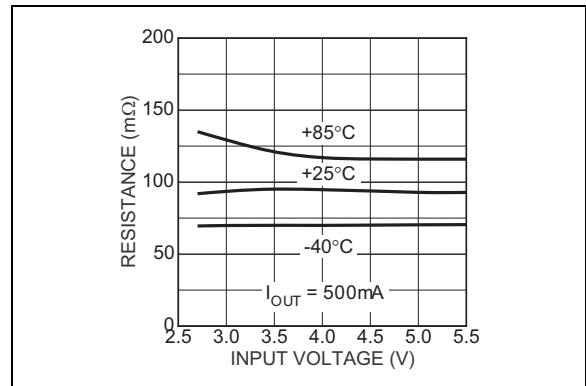

FIGURE 2-5: On-Resistance vs. Input Voltage.

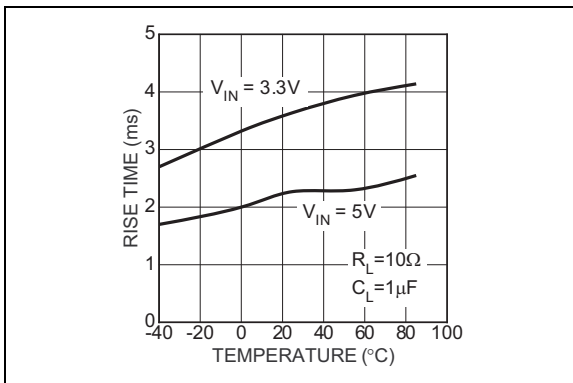

FIGURE 2-3: Turn-On rise Time vs. Temperature.

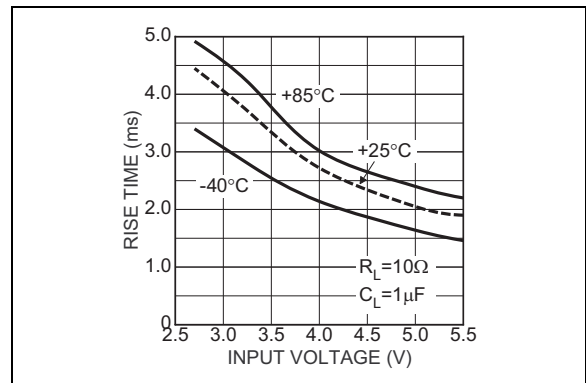

FIGURE 2-6: Turn-On Rise Time vs. Input Voltage.

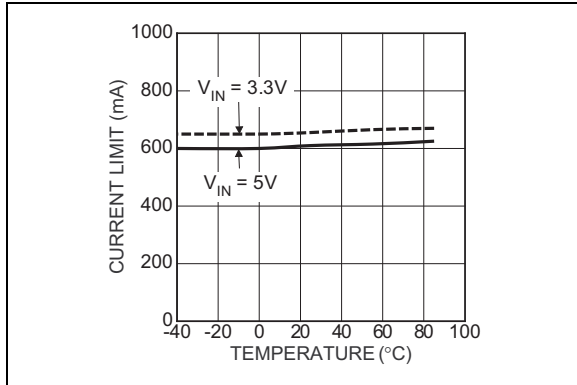

FIGURE 2-7: Short-Circuit Current-Limit vs. Temperature.

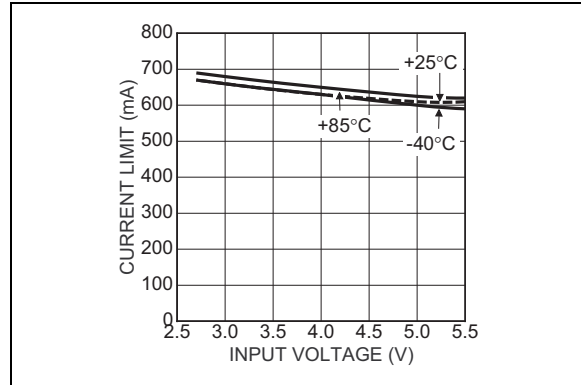

FIGURE 2-10: Short-Circuit Current-Limit vs. Input Voltage.

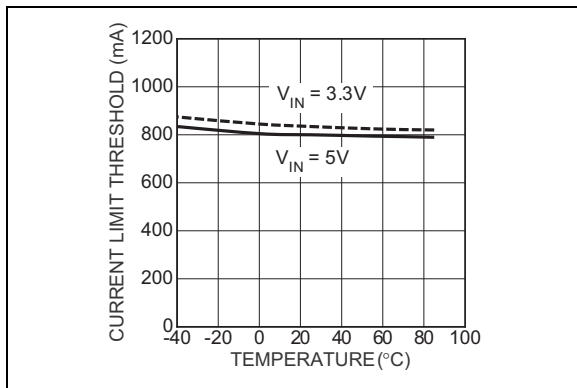

FIGURE 2-8: Current-Limit Threshold vs. Temperature.

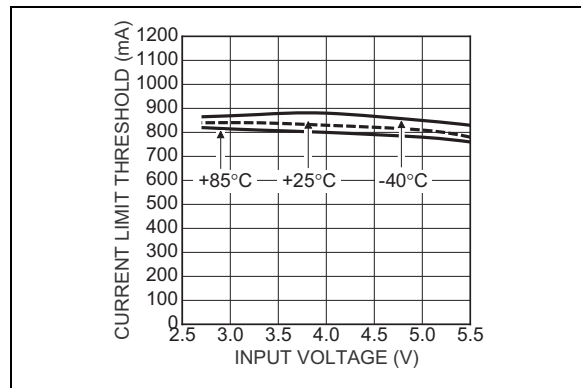

FIGURE 2-11: Current-Limit Threshold vs. Input Voltage.

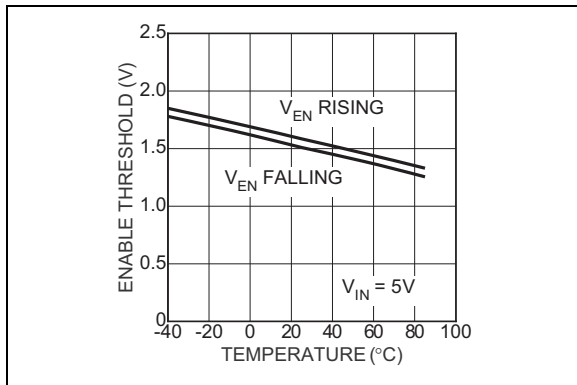

FIGURE 2-9: Enable Threshold vs. Temperature.

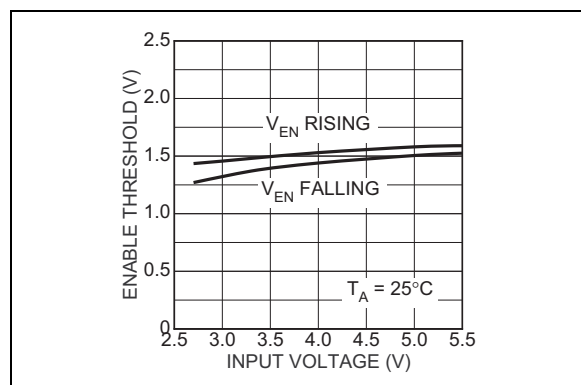

FIGURE 2-12: Enable Threshold vs. Input Voltage.

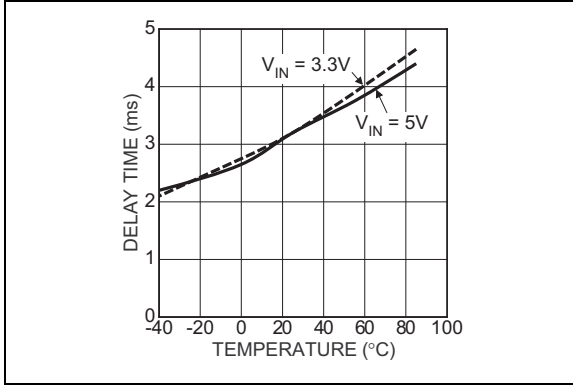

FIGURE 2-13: Flag Delay vs. Temperature.

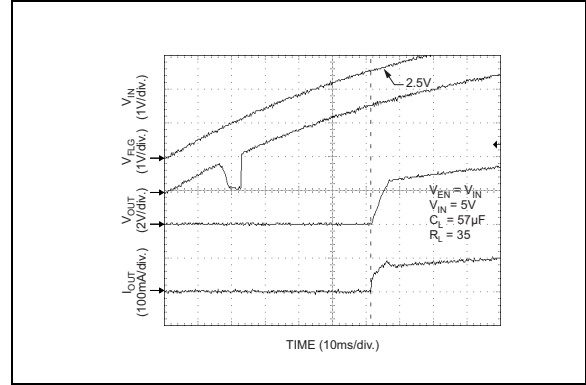

FIGURE 2-16: UVLO V_{IN} Rising (MIC2025-1).

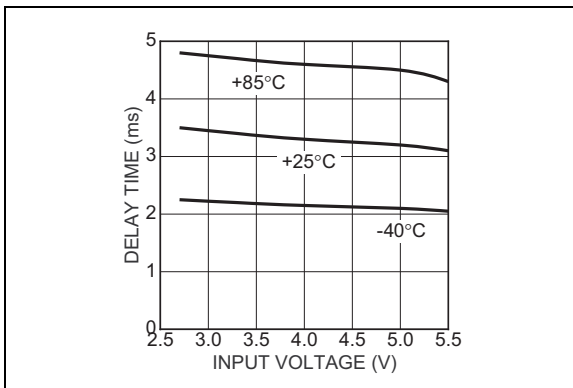

FIGURE 2-14: Flag Delay vs. Input Voltage.

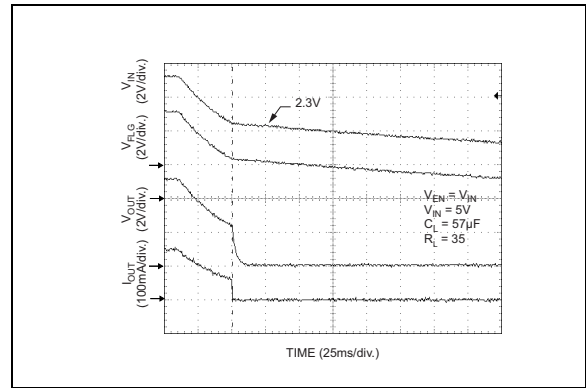

FIGURE 2-17: UVLO V_{IN} Falling (MIC2025-1).

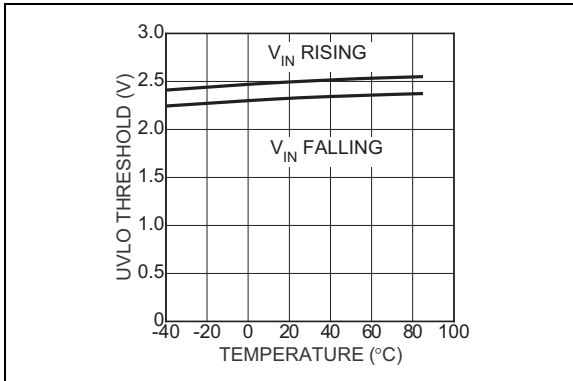

FIGURE 2-15: UVLO Threshold vs. Temperature.

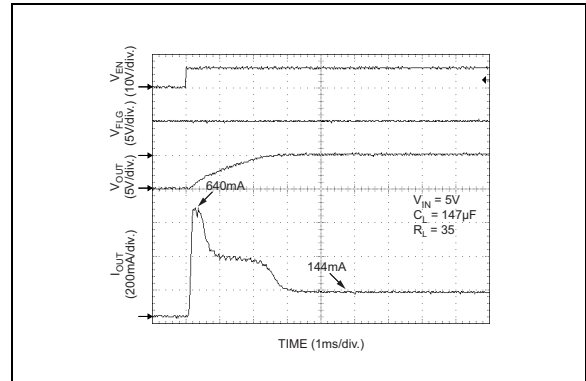

FIGURE 2-18: Turn-On Response (MIC2025-1).

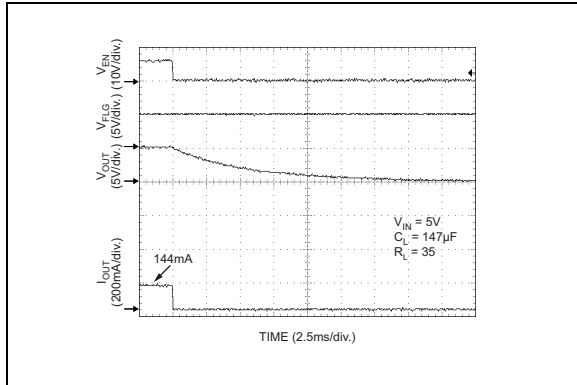

FIGURE 2-19: Turn-Off Response (MIC2025-1).

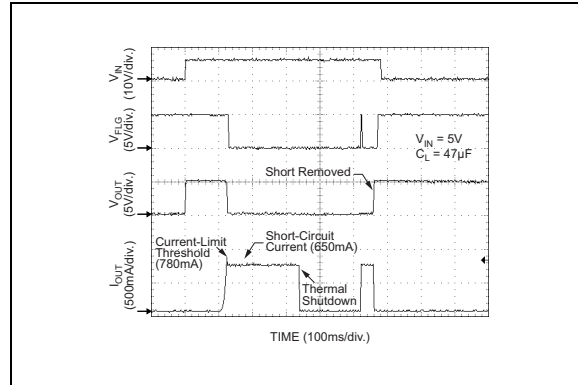

FIGURE 2-22: Current-Limit Response (Ramped Load Into Short MIC2025-1).

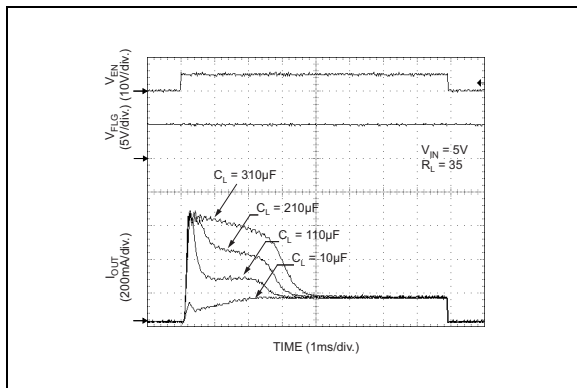

FIGURE 2-20: In-Rush Current Response (MIC2025-1).

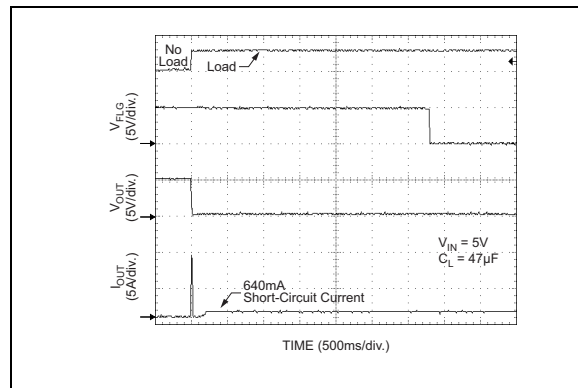

FIGURE 2-23: Current-Limit Transient Response (Enable Into Short MIC2025-1).

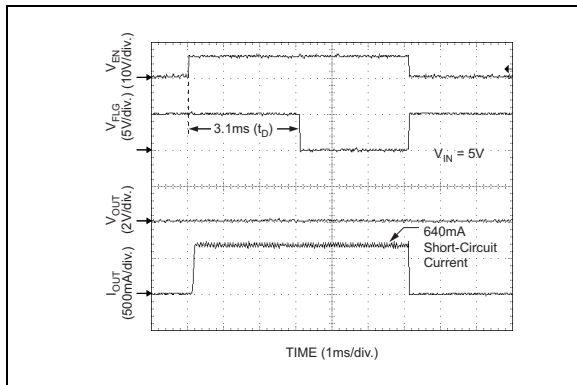

FIGURE 2-21: Enable Into Short (MIC2025-1).

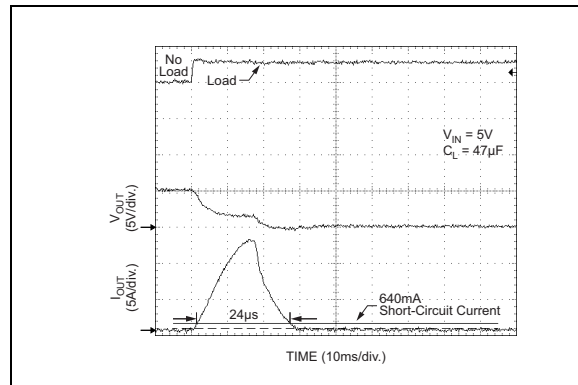

FIGURE 2-24: Current-Limit Transient Response (MIC2025-1).

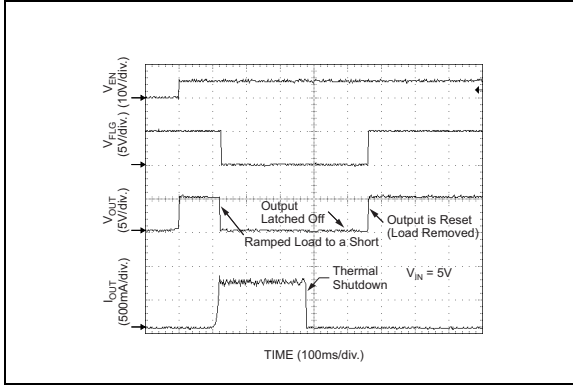

FIGURE 2-25: Thermal Shutdown Response (Output Reset By Removing Load MIC2075-1).

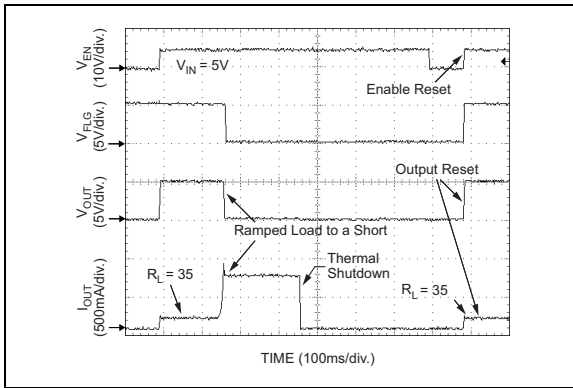

FIGURE 2-26: Thermal Shutdown Response (Output Reset By Toggling Enable MIC2075-1).

MIC2025/2075

3.0 PIN DESCRIPTIONS

The descriptions of the pins are listed in [Table 3-1](#).

TABLE 3-1: PIN FUNCTION TABLE

Pin Number	Pin Name	Description
1	EN	Switch Enable (Input): Active-high (-1) or Active-low (-2).
2	FLG	Fault Flag (Output): Active-low, open-drain output. Indicates overcurrent or thermal shutdown conditions. Overcurrent condition must exceed t_D in order to assert FLG.
3	GND	Ground.
4	NC	Not internally connected.
5	NC	Not internally connected.
6, 8	OUT	Supply (Output): Pins must be connected together.
7	IN	Supply voltage (Input).

4.0 FUNCTIONAL DESCRIPTION

4.1 Input and Output

IN is the power supply connection to the logic circuitry and the drain of the output MOSFET. OUT is the source of the output MOSFET. In a typical circuit, current flows from IN to OUT toward the load. If V_{OUT} is greater than V_{IN} , current will flow from OUT to IN, since the switch is bidirectional when enabled. The output MOSFET and driver circuitry are also designed to allow the MOSFET source to be externally forced to a higher voltage than the drain ($V_{OUT} > V_{IN}$) when the switch is disabled. In this situation, the MIC2025/75 prevents undesirable current flow from OUT to IN.

4.2 Thermal Shutdown

Thermal shutdown is employed to protect the device from damage should the die temperature exceed safe margins due mainly to short circuit faults. Thermal shutdown shuts off the output MOSFET and asserts the FLG output if the die temperature reaches 140°C. The MIC2025 will automatically reset its output should the die temperature cool down to 120°C. The MIC2025 output and FLG signal will continue to cycle on and off until the device is disabled or the fault is removed. [Figure 4-2](#) depicts typical timing. If the MIC2075 goes into thermal shutdown, its output will latch off and a pull-up current source is activated. This allows the output latch to automatically reset when the load (such as a USB device) is removed. The output can also be reset by toggling EN. Refer to [Figure 4-1](#) for details.

Depending on PCB layout, package, ambient temperature, etc., it may take several hundred milliseconds from the incidence of the fault to the output MOSFET being shut off. The worst-case scenario of thermal shutdown is that of a short-circuit fault and is shown in [Figure 2-25](#) and [Figure 2-26](#).

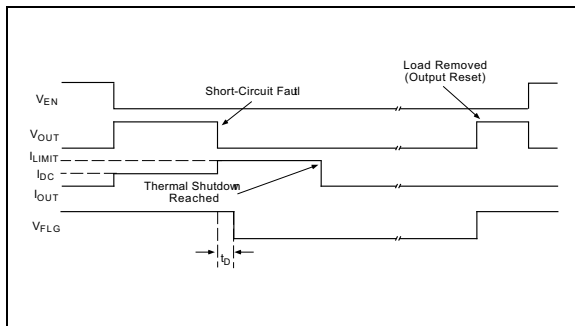

FIGURE 4-1: MIC2075-2 Timing: Output Reset by Removing Load.

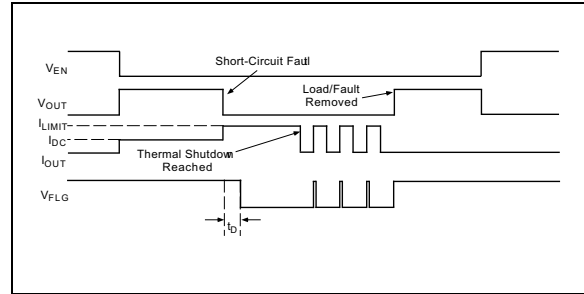

FIGURE 4-2: MIC2025-2 Timing.

4.3 Power Dissipation

The device's junction temperature depends on several factors such as the load, PCB layout, ambient temperature, and package type. Equations that can be used to calculate power dissipation and junction temperature are found in [Equation 4-1](#) and [Equation 4-2](#).

EQUATION 4-1:

$$P_D = R_{DS(on)} \times I_{OUT}^2$$

EQUATION 4-2:

$$T_J = P_D \times \theta_{JA} + T_A$$

Where:

- T_J = Junction Temperature
- T_A = Ambient Temperature
- θ_{JA} = The Thermal Resistance of the Package

4.4 Current Sensing and Limiting

The current-limit threshold is preset internally. The preset level prevents damage to the device and external load but still allows a minimum current of 500 mA to be delivered to the load.

The current-limit circuit senses a portion of the output MOSFET switch current. The current-sense resistor shown in the [Functional Block Diagram](#) is virtual and has no voltage drop. The reaction to an overcurrent condition varies with three scenarios:

4.4.1 SWITCH ENABLED INTO SHORT-CIRCUIT

If a switch is enabled into a heavy load or short-circuit, the switch immediately enters into a constant-current mode, reducing the output voltage. The FLG signal is asserted indicating an overcurrent condition. See [Figure 2-21](#).

4.4.2 SHORT-CIRCUIT APPLIED TO ENABLED OUTPUT

When a heavy load or short-circuit is applied to an enabled switch, a large transient current may flow until the current-limit circuitry responds. Once this occurs, the device limits current to less than the short-circuit current limit specification. See [Figure 2-23](#).

4.4.3 CURRENT-LIMIT RESPONSE - RAMPED LOAD

The MIC2025/75 current-limit profile exhibits a small foldback effect of about 200 mA. Once this current-limit threshold is exceeded the device switches into a constant current mode. It is important to note that the device will supply current until the current-limit threshold is exceeded. See [Figure 2-22](#).

4.5 Fault Flag

The FLG signal is an N-channel open-drain MOSFET output. FLG is asserted (active-low) when either an overcurrent or thermal shutdown condition occurs. In the case of an overcurrent condition, FLG will be asserted only after the flag response delay time, t_D , has elapsed. This ensures that FLG is asserted only upon valid overcurrent conditions and that erroneous error reporting is eliminated. For example, false overcurrent conditions can occur during hot plug events when a highly capacitive load is connected and causes a high transient inrush current that exceeds the current-limit threshold. The FLG response delay time t_D is typically 3 ms.

4.6 Undervoltage Lockout

Undervoltage lockout (UVLO) prevents the output MOSFET from turning on until V_{IN} exceeds approximately 2.5V. Undervoltage detection functions only when the switch is enabled.

5.0 APPLICATION INFORMATION

5.1 Supply Filtering

A 0.1 μF to 1 μF bypass capacitor positioned close to VIN and GND of the device is strongly recommended to control supply transients. Without a bypass capacitor, an output short may cause sufficient ringing on the input (from supply lead inductance) to damage internal control circuitry.

5.2 Printed Circuit Board Hot-Plug

The MIC2025/75 are ideal inrush current-limiters for hot plug applications. Due to their integrated charge pumps, the MIC2025/75 present a high impedance when off and slowly become a low impedance as their integrated charge pumps turn on. This soft-start feature effectively isolates power supplies from highly capacitive loads by reducing inrush current. Equation 5-1 shows how the MIC2075 may be used in a card hot-plug application.

In cases of extremely large capacitive loads ($>400 \mu\text{F}$), the length of the transient due to inrush current may exceed the delay provided by the integrated filter. Since this inrush current exceeds the current-limit delay specification, FLG will be asserted during this time. To prevent the logic controller from responding to FLG being asserted, an external RC filter, as shown in Equation 5-2, can be used to filter out transient FLG assertion. The value of the RC time constant should be selected to match the length of the transient, less $t_{D(\text{min})}$ of the MIC2025/75.

5.3 Universal Serial Bus (USB) Power Distribution

The MIC2025/75 are ideally suited for USB (Universal Serial Bus) power distribution applications. The USB specification defines power distribution for USB host systems such as PCs and USB hubs. Hubs can either be self-powered or bus-powered (that is, powered from the bus). Equation 5-3 shows a typical USB Host application that may be suited for mobile PC applications employing USB. The requirement for USB host systems is that the port must supply a minimum of 500 mA at an output voltage of $5\text{V} \pm 5\%$. In addition, the output power delivered must be limited to below 25 VA. Upon an overcurrent condition, the host must also be notified. To support hot-plug events, the hub must have a minimum of 120 μF of bulk capacitance, preferably low ESR electrolytic or tantalum. Please refer to Application Note 17 for more details on designing compliant USB hub and host systems.

For bus-powered hubs, USB requires that each downstream port be switched on or off under control by the host. Up to four downstream ports each capable of supplying 100 mA at 4.4V minimum are allowed. In addition, to reduce voltage droop on the upstream

V_{BUS} , soft-start is necessary. Although the hub can consume up to 500 mA from the upstream bus, the hub must consume only 100 mA max at start-up, until it enumerates with the host prior to requesting more power. The same requirements apply for bus-powered peripherals that have no downstream ports. Equation 5-4 shows a bus-powered hub.

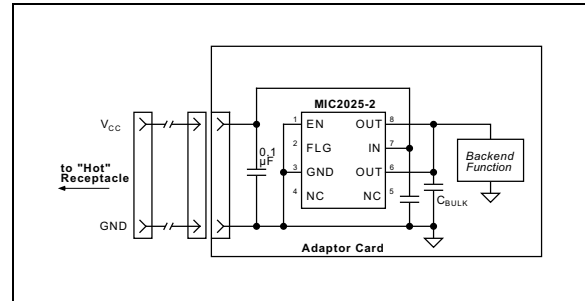

FIGURE 5-1: Hot-Plug Application.

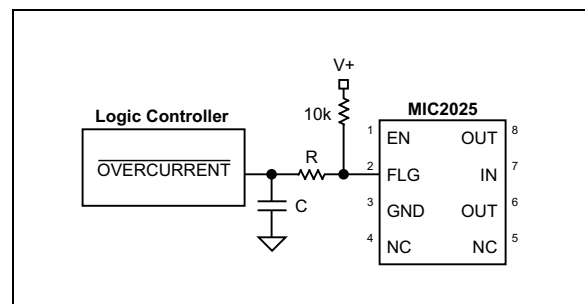

FIGURE 5-2: Transient Filter.

MIC2025/2075

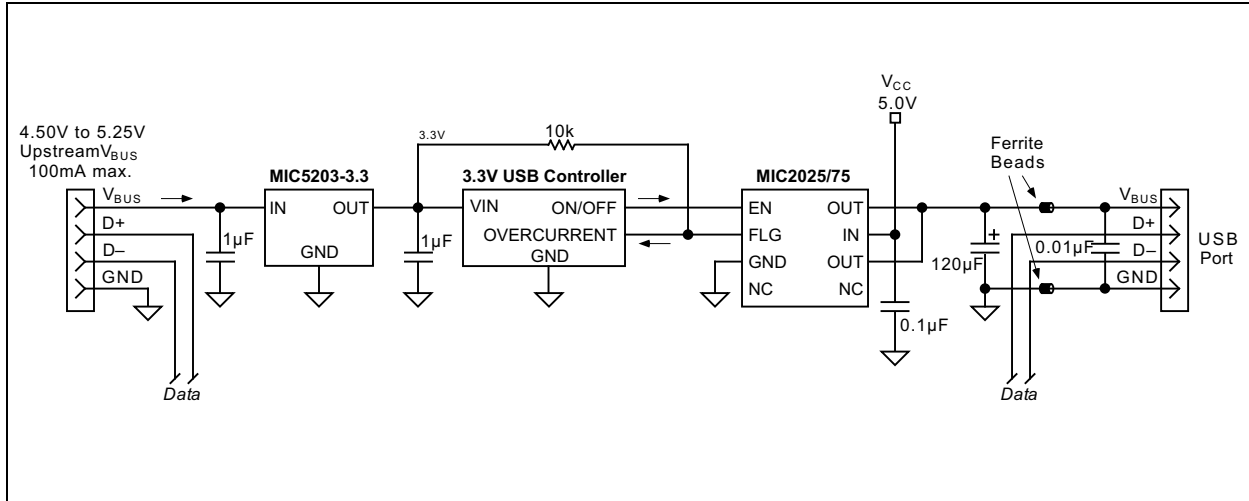

FIGURE 5-3: USB Host Application.

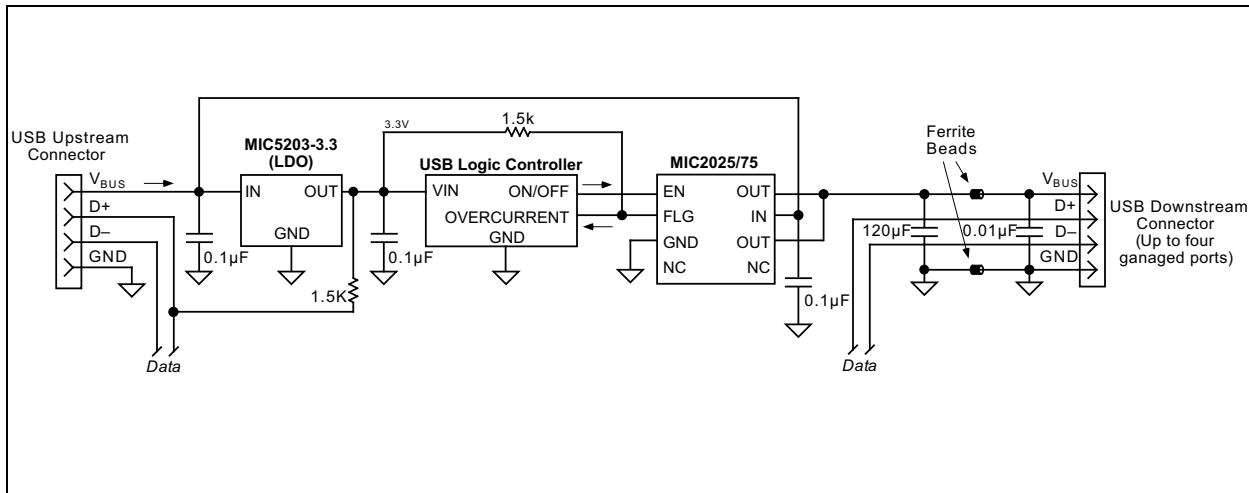
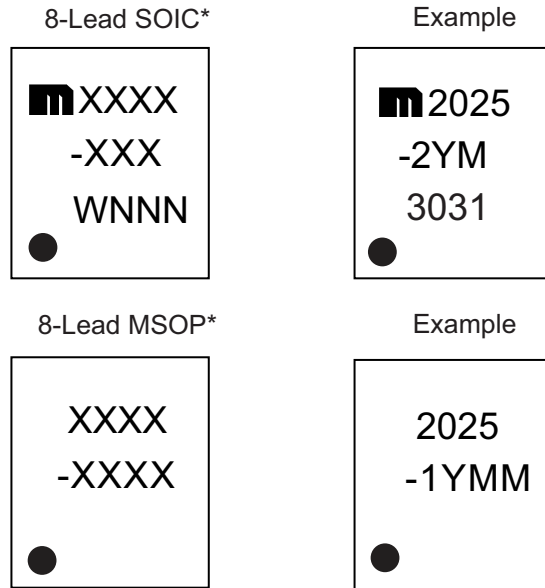

FIGURE 5-4: USB Bus-Powered Hub.

6.0 PACKAGING INFORMATION

6.1 Package Marking Information



<p>Legend:</p> <p>XX...X Product code or customer-specific information</p> <p>Y Year code (last digit of calendar year)</p> <p>YY Year code (last 2 digits of calendar year)</p> <p>WW Week code (week of January 1 is week '01')</p> <p>NNN Alphanumeric traceability code</p> <p>(e3) Pb-free JEDEC® designator for Matte Tin (Sn)</p> <p>* This package is Pb-free. The Pb-free JEDEC designator (e3) can be found on the outer packaging for this package.</p> <p>•, ▲, ▼ Pin one index is identified by a dot, delta up, or delta down (triangle mark).</p>
<p>Note: In the event the full Microchip part number cannot be marked on one line, it will be carried over to the next line, thus limiting the number of available characters for customer-specific information. Package may or may not include the corporate logo.</p> <p>Underbar () and/or Overbar () symbol may not be to scale.</p>

MIC2025/2075

8-Lead SOIC-8 Package Outline and Recommended Land Pattern

TITLE

8 LEAD SOICN PACKAGE OUTLINE & RECOMMENDED LAND PATTERN

DRAWING #	SOICN-8LD-PL-1	UNIT	INCH [MM]
------------------	----------------	-------------	-----------

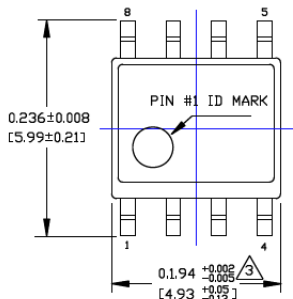

TOP VIEW

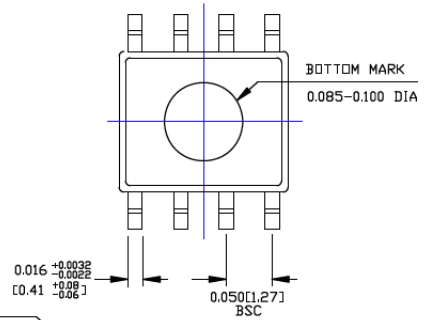

BOTTOM VIEW

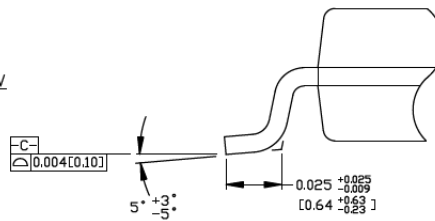

DETAIL "A"

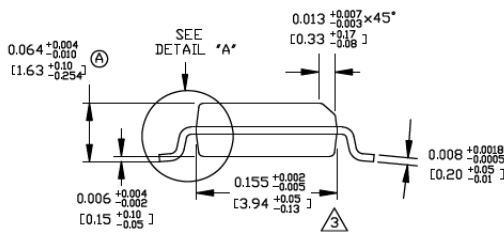

END VIEW

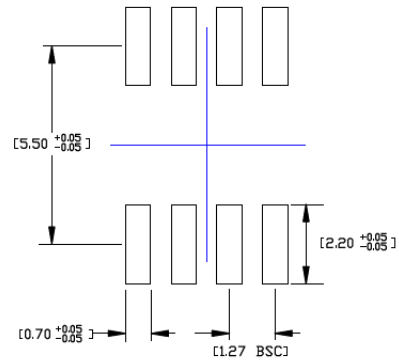

RECOMMENDED LAND PATTERN

NOTES:

1. DIMENSIONS ARE IN INCHES[MM].
2. CONTROLLING DIMENSION: INCHES.
3. DIMENSION DOES NOT INCLUDE MOLD FLASH OR PROTRUSIONS, EITHER OF WHICH SHALL NOT EXCEED 0.010[0.25] PER SIDE.

Note: For the most current package drawings, please see the Microchip Packaging Specification located at <http://www.microchip.com/packaging>.

8-Lead MSOP-8 Package Outline and Recommended Land Pattern

TITLE

8 LEAD MSOP PACKAGE OUTLINE & RECOMMENDED LAND PATTERN

DRAWING #	MSOP-8LD-PL-1	UNIT	INCH [MM]
-----------	---------------	------	-----------

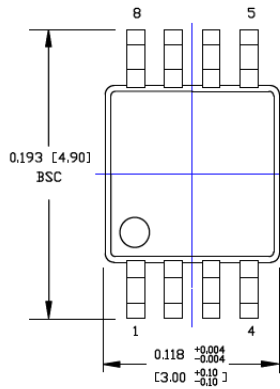

TOP VIEW

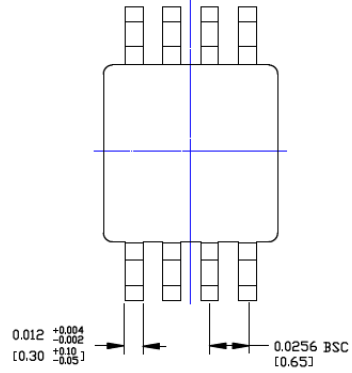

BOTTOM VIEW

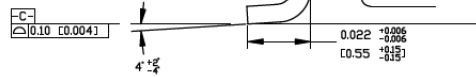

DETAIL A

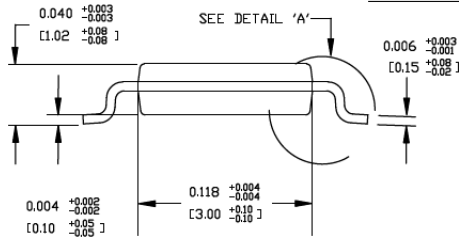

SIDE VIEW

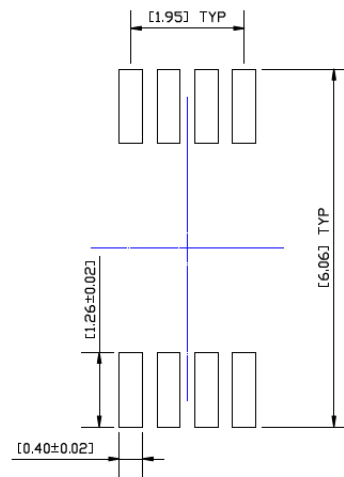

RECOMMENDED LAND PATTERN

NOTES:

1. DIMENSIONS ARE IN INCHES [MM].
2. CONTROLLING DIMENSION: MM
3. DIMENSION DOES NOT INCLUDE MOLD FLASH OR PROTRUSIONS, EITHER OF WHICH SHALL NOT EXCEED 0.008 [0.20] PER SIDE.

Note: For the most current package drawings, please see the Microchip Packaging Specification located at <http://www.microchip.com/packaging>.

APPENDIX A: REVISION HISTORY

Revision A (June 2018)

- Converted Micrel document MIC2025/2075 to Microchip data sheet DS20006030A.
- Minor text changes throughout.

MIC2025/2075

NOTES:

PRODUCT IDENTIFICATION SYSTEM

To order or obtain information, e.g., on pricing or delivery, contact your local Microchip representative or sales office.

<u>PART NO.</u>	<u>-X</u>	<u>X</u>	<u>XX</u>	<u>-XX</u>	Examples:	
Device	Control/Enable	Junction Temperature Range	Package	Media Type		
Device:	MIC2025:	Single Channel Power Distribution Switch			a) MIC2025-1YM:	Single Channel Power Distribution Switch, Active-High Control Enable, -40°C to +85°C Temp. Range, 8-Lead SOIC Package, 95/Tube
	MIC2075:	Single Channel Power Distribution Switch with Circuit Breaker Mode			b) MIC2025-2YMM:	Single Channel Power Distribution Switch, Active-Low Control Enable, -40°C to +85°C Temp. Range, 8-Lead MSOP Package, 100/Tube
Control/Enable:	1 =	Active-High			c) MIC2025-1YM-TR:	Single Channel Power Distribution Switch, Active-High Control Enable, -40°C to +85°C Temp. Range, 8-Lead SOIC Package, 2,500/Reel
	2 =	Active-Low			d) MIC2025-2YMM-TR:	Single Channel Power Distribution Switch, Active-Low Control Enable, -40°C to +85°C Temp. Range, 8-Lead MSOP Package, 2,500/Reel
Junction Temperature Range:	Y =	-40°C to +85°C (RoHs Compliant, Pb-Free, Halogen Free)			e) MIC2075-1YM	Single Channel Power Distribution Switch with Circuit Breaker Mode, Active-High Control Enable, -40°C to +85°C Temp. Range, 8-Lead SOIC Package, 95/Tube
Package:	M =	8-Lead SOIC			f) MIC2075-1YM-TR:	Single Channel Power Distribution Switch with Circuit Breaker Mode, Active-High Control Enable, -40°C to +85°C Temp. Range, 8-Lead SOIC Package, 2,500/Reel
	MM =	8-Lead MSOP			g) MIC2075-2YMM-TR:	Single Channel Power Distribution Switch with Circuit Breaker Mode, Active-Low Control Enable, -40°C to +85°C Temp. Range, 8-Lead MSOP Package, 2,500/Reel
Media Type:	Blank =	95/Tube			Note 1:	Tape and Reel identifier only appears in the catalog part number description. This identifier is used for ordering purposes and is not printed on the device package. Check with your Microchip Sales Office for package availability with the Tape and Reel option.
	Blank =	100/Tube				
	TR =	2,500/Reel				

Note the following details of the code protection feature on Microchip devices:

- Microchip products meet the specification contained in their particular Microchip Data Sheet.
- Microchip believes that its family of products is one of the most secure families of its kind on the market today, when used in the intended manner and under normal conditions.
- There are dishonest and possibly illegal methods used to breach the code protection feature. All of these methods, to our knowledge, require using the Microchip products in a manner outside the operating specifications contained in Microchip's Data Sheets. Most likely, the person doing so is engaged in theft of intellectual property.
- Microchip is willing to work with the customer who is concerned about the integrity of their code.
- Neither Microchip nor any other semiconductor manufacturer can guarantee the security of their code. Code protection does not mean that we are guaranteeing the product as “unbreakable.”

Code protection is constantly evolving. We at Microchip are committed to continuously improving the code protection features of our products. Attempts to break Microchip's code protection feature may be a violation of the Digital Millennium Copyright Act. If such acts allow unauthorized access to your software or other copyrighted work, you may have a right to sue for relief under that Act.

Information contained in this publication regarding device applications and the like is provided only for your convenience and may be superseded by updates. It is your responsibility to ensure that your application meets with your specifications. MICROCHIP MAKES NO REPRESENTATIONS OR WARRANTIES OF ANY KIND WHETHER EXPRESS OR IMPLIED, WRITTEN OR ORAL, STATUTORY OR OTHERWISE, RELATED TO THE INFORMATION, INCLUDING BUT NOT LIMITED TO ITS CONDITION, QUALITY, PERFORMANCE, MERCHANTABILITY OR FITNESS FOR PURPOSE. Microchip disclaims all liability arising from this information and its use. Use of Microchip devices in life support and/or safety applications is entirely at the buyer's risk, and the buyer agrees to defend, indemnify and hold harmless Microchip from any and all damages, claims, suits, or expenses resulting from such use. No licenses are conveyed, implicitly or otherwise, under any Microchip intellectual property rights unless otherwise stated.

Microchip received ISO/TS-16949:2009 certification for its worldwide headquarters, design and wafer fabrication facilities in Chandler and Tempe, Arizona; Gresham, Oregon and design centers in California and India. The Company's quality system processes and procedures are for its PIC[®] MCUs and dsPIC[®] DSCs, KEELoQ[®] code hopping devices, Serial EEPROMs, microperipherals, nonvolatile memory and analog products. In addition, Microchip's quality system for the design and manufacture of development systems is ISO 9001:2000 certified.

**QUALITY MANAGEMENT SYSTEM
CERTIFIED BY DNV
= ISO/TS 16949 =**

Trademarks

The Microchip name and logo, the Microchip logo, AnyRate, AVR, AVR logo, AVR Freaks, BeaconThings, BitCloud, CryptoMemory, CryptoRF, dsPIC, FlashFlex, flexPWR, Heldo, JukeBlox, KEELoQ, KEELoQ logo, Klear, LANCheck, LINK MD, maXStylus, maXTouch, MediaLB, megaAVR, MOST, MOST logo, MPLAB, OptoLyzer, PIC, picoPower, PICSTART, PIC32 logo, Prochip Designer, QTouch, RightTouch, SAM-BA, SpyNIC, SST, SST Logo, SuperFlash, tinyAVR, UNI/O, and XMEGA are registered trademarks of Microchip Technology Incorporated in the U.S.A. and other countries.

ClockWorks, The Embedded Control Solutions Company, EtherSynch, Hyper Speed Control, HyperLight Load, IntelliMOS, mTouch, Precision Edge, and Quiet-Wire are registered trademarks of Microchip Technology Incorporated in the U.S.A.

Adjacent Key Suppression, AKS, Analog-for-the-Digital Age, Any Capacitor, AnyIn, AnyOut, BodyCom, chipKIT, chipKIT logo, CodeGuard, CryptoAuthentication, CryptoCompanion, CryptoController, dsPICDEM, dsPICDEM.net, Dynamic Average Matching, DAM, ECAN, EtherGREEN, In-Circuit Serial Programming, ICSP, Inter-Chip Connectivity, JitterBlocker, KlearNet, KlearNet logo, Mindi, MiWi, motorBench, MPASM, MPF, MPLAB Certified logo, MPLIB, MPLINK, MultiTRAK, NetDetach, Omniscient Code Generation, PICDEM, PICDEM.net, PICKit, PICTail, PureSilicon, QMatrix, RightTouch logo, REAL ICE, Ripple Blocker, SAM-ICE, Serial Quad I/O, SMART-I.S., SQI, SuperSwitcher, SuperSwitcher II, Total Endurance, TSHARC, USBCheck, VariSense, ViewSpan, WiperLock, Wireless DNA, and ZENA are trademarks of Microchip Technology Incorporated in the U.S.A. and other countries.

SQTP is a service mark of Microchip Technology Incorporated in the U.S.A.

Silicon Storage Technology is a registered trademark of Microchip Technology Inc. in other countries.

GestIC is a registered trademark of Microchip Technology Germany II GmbH & Co. KG, a subsidiary of Microchip Technology Inc., in other countries.

All other trademarks mentioned herein are property of their respective companies.

© 2018, Microchip Technology Incorporated, All Rights Reserved.
ISBN: 978-1-5224-3276-0



MICROCHIP

Worldwide Sales and Service

AMERICAS

Corporate Office
2355 West Chandler Blvd.
Chandler, AZ 85224-6199
Tel: 480-792-7200
Fax: 480-792-7277
Technical Support:
<http://www.microchip.com/support>
Web Address:
www.microchip.com

Atlanta

Duluth, GA
Tel: 678-957-9614
Fax: 678-957-1455

Austin, TX

Tel: 512-257-3370

Boston

Westborough, MA
Tel: 774-760-0087
Fax: 774-760-0088

Chicago

Itasca, IL
Tel: 630-285-0071
Fax: 630-285-0075

Dallas

Addison, TX
Tel: 972-818-7423
Fax: 972-818-2924

Detroit

Novi, MI
Tel: 248-848-4000

Houston, TX

Tel: 281-894-5983

Indianapolis

Noblesville, IN
Tel: 317-773-8323
Fax: 317-773-5453
Tel: 317-536-2380

Los Angeles

Mission Viejo, CA
Tel: 949-462-9523
Fax: 949-462-9608
Tel: 951-273-7800

Raleigh, NC

Tel: 919-844-7510

New York, NY

Tel: 631-435-6000

San Jose, CA

Tel: 408-735-9110
Tel: 408-436-4270

Canada - Toronto

Tel: 905-695-1980
Fax: 905-695-2078

ASIA/PACIFIC

Australia - Sydney
Tel: 61-2-9868-6733

China - Beijing
Tel: 86-10-8569-7000

China - Chengdu
Tel: 86-28-8665-5511

China - Chongqing
Tel: 86-23-8980-9588

China - Dongguan
Tel: 86-769-8702-9880

China - Guangzhou
Tel: 86-20-8755-8029

China - Hangzhou
Tel: 86-571-8792-8115

China - Hong Kong SAR
Tel: 852-2943-5100

China - Nanjing
Tel: 86-25-8473-2460

China - Qingdao
Tel: 86-532-8502-7355

China - Shanghai
Tel: 86-21-3326-8000

China - Shenyang
Tel: 86-24-2334-2829

China - Shenzhen
Tel: 86-755-8864-2200

China - Suzhou
Tel: 86-186-6233-1526

China - Wuhan
Tel: 86-27-5980-5300

China - Xian
Tel: 86-29-8833-7252

China - Xiamen
Tel: 86-592-2388138

China - Zhuhai
Tel: 86-756-3210040

ASIA/PACIFIC

India - Bangalore
Tel: 91-80-3090-4444

India - New Delhi
Tel: 91-11-4160-8631

India - Pune
Tel: 91-20-4121-0141

Japan - Osaka
Tel: 81-6-6152-7160

Japan - Tokyo
Tel: 81-3-6880-3770

Korea - Daegu
Tel: 82-53-744-4301

Korea - Seoul
Tel: 82-2-554-7200

Malaysia - Kuala Lumpur
Tel: 60-3-7651-7906

Malaysia - Penang
Tel: 60-4-227-8870

Philippines - Manila
Tel: 63-2-634-9065

Singapore
Tel: 65-6334-8870

Taiwan - Hsin Chu
Tel: 886-3-577-8366

Taiwan - Kaohsiung
Tel: 886-7-213-7830

Taiwan - Taipei
Tel: 886-2-2508-8600

Thailand - Bangkok
Tel: 66-2-694-1351

Vietnam - Ho Chi Minh
Tel: 84-28-5448-2100

EUROPE

Austria - Wels
Tel: 43-7242-2244-39
Fax: 43-7242-2244-393

Denmark - Copenhagen
Tel: 45-4450-2828
Fax: 45-4485-2829

Finland - Espoo
Tel: 358-9-4520-820

France - Paris
Tel: 33-1-69-53-63-20
Fax: 33-1-69-30-90-79

Germany - Garching
Tel: 49-8931-9700

Germany - Haan
Tel: 49-2129-3766400

Germany - Heilbronn
Tel: 49-7131-67-3636

Germany - Karlsruhe
Tel: 49-721-625370

Germany - Munich
Tel: 49-89-627-144-0
Fax: 49-89-627-144-44

Germany - Rosenheim
Tel: 49-8031-354-560

Israel - Ra'anana
Tel: 972-9-744-7705

Italy - Milan
Tel: 39-0331-742611
Fax: 39-0331-466781

Italy - Padova
Tel: 39-049-7625286

Netherlands - Drunen
Tel: 31-416-690399
Fax: 31-416-690340

Norway - Trondheim
Tel: 47-7289-7561

Poland - Warsaw
Tel: 48-22-3325737

Romania - Bucharest
Tel: 40-21-407-87-50

Spain - Madrid
Tel: 34-91-708-08-90
Fax: 34-91-708-08-91

Sweden - Gothenberg
Tel: 46-31-704-60-40

Sweden - Stockholm
Tel: 46-8-5090-4654

UK - Wokingham
Tel: 44-118-921-5800
Fax: 44-118-921-5820

Looking for pricing, stock, or lifecycle information?

Click below to explore more details on WIN SOURCE:

- ⊖ [View MIC2075-1BM on WIN SOURCE](#)
- ⊖ [Microchip Technology](#) Information

Optimize Your Supply Chain with WIN SOURCE Solutions

- ✓ Global Sourcing Solution
- ✓ Obsolete Management
- ✓ Cost Control Management
- ✓ Shortage Management
- ✓ Alternative Solution
- ✓ Excess Inventory Management