



THE DATASHEET OF MIC2027-1YM





MIC2027/2077

Quad USB Power Distribution Switch

General Description

The MIC2027 and MIC2077 are quad high-side MOSFET switches optimized for general-purpose power distribution requiring circuit protection. The MIC2027/77 are internally current limited and have thermal shutdown that protects the device and load.

The MIC2077 offers “smart” thermal shutdown that reduces current consumption in fault modes. When a thermal shutdown fault occurs, the output is latched off until the faulty load is removed. Removing the load or toggling the enable input will reset the device output.

Both devices employ soft-start circuitry that minimizes inrush current in applications where highly capacitive loads are employed.

A fault status output flag is asserted during overcurrent and thermal shutdown conditions. Transient current limit faults are internally filtered.

The MIC2027/77 are available in 16-pin narrow (150 mil) and wide (300 mil) SOIC packages.

Data sheets and support documentation can be found on Micrel’s web site at www.micrel.com.

Features

- 150mΩ maximum on-resistance per channel
- 2.7V to 5.5V operating range
- 500mA minimum continuous current per channel
- Short-circuit protection with thermal shutdown
- Thermally isolated channels
- Fault status flag with 3ms filter eliminates false assertions
- Undervoltage lockout
- Reverse current flow blocking (no “body diode”)
- Circuit breaker mode (MIC2077) reduces power consumption
- Logic-compatible inputs
- Soft-start circuit
- Low quiescent current
- Pin compatible with MIC2524 and MIC2527

Applications

- USB peripherals
- General purpose power switching
- ACPI power distribution
- Notebook PCs
- PDAs
- PC card hot swap

Typical Application

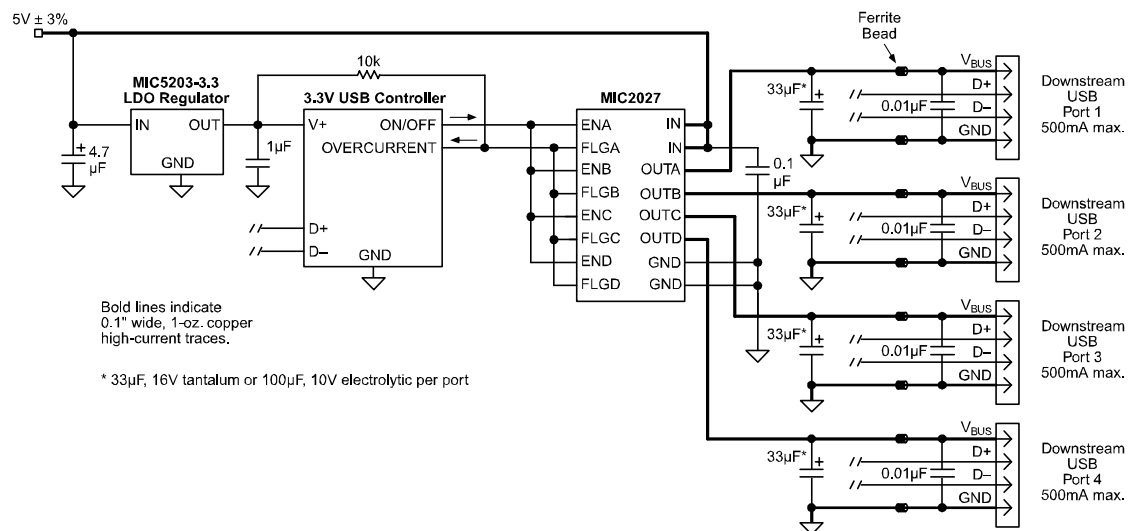

4-Port Self-Powered Hub



UL Recognized Component

Ordering Information⁽¹⁾

Part Number		Enable	Temperature Range	Package
Standard	Pb-Free			
MIC2027-1BWM	MIC2027-1YWM	Active High	-40°C to +85°C	16-Pin Wide SOIC
MIC2027-1BM	MIC2027-1YM	Active High	-40°C to +85°C	16-Pin SOIC
MIC2027-2BWM	MIC2027-2YWM	Active Low	-40°C to +85°C	16-Pin Wide SOIC
MIC2027-2BM	MIC2027-2YM	Active Low	-40°C to +85°C	16-Pin SOIC
MIC2077-1BWM	MIC2077-1YWM	Active High	-40°C to +85°C	16-Pin Wide SOIC
MIC2077-1BM	MIC2077-1YM	Active High	-40°C to +85°C	16-Pin SOIC
MIC2077-2BWM	MIC2077-2YWM	Active Low	-40°C to +85°C	16-Pin Wide SOIC
MIC2077-2BM	MIC2077-2YM	Active Low	-40°C to +85°C	16-Pin SOIC

Pin Configuration

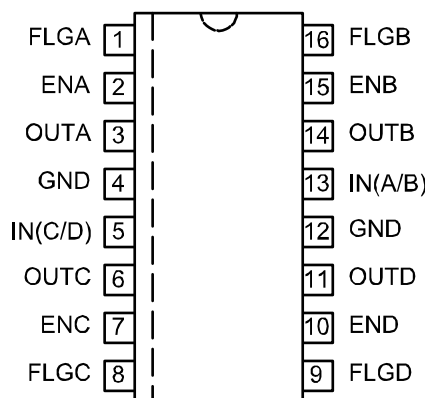

16-Pin SOIC (M)
16-Pin Wide SOIC (WM)

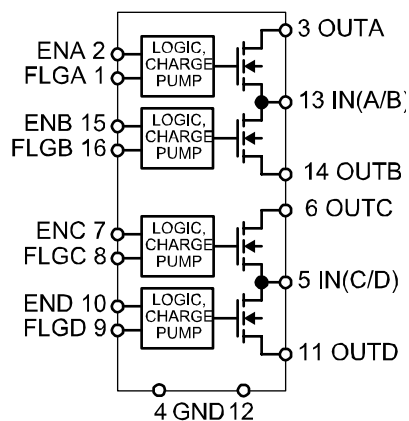

Functional Pinout

Pin Description

Pin Number	Pin Name	Pin Function
1	FLG	Fault Flag A (Output): Active-low, open-drain output. Low indicates overcurrent or thermal shutdown conditions. Overcurrent conditions must last longer than t_D to assert flag.
2	ENA	Switch A Enable (Input): Logic-compatible enable input. Active high (-1) or active low (-2).
3	OUTA	Switch A Output
4, 12	GND	Ground
5	IN(C/D)	Input: Channel C and D switch and logic supply input.
6	OUTC	Switch C Output
7	ENC	Switch C Enable (Input)
8	FLGC	Fault Flag C (Output)
9	FLGD	Fault Flag D (Output)
10	END	Switch D Enable (Input)
11	OUTD	Switch D Output
13	IN(A/B)	Supply Input: Channel A and B switch and logic supply input.
14	OUTB	Switch B Output
15	ENB	Switch B Enable (Input)
16	FLGB	Fault Flag B (Output)

Absolute Maximum Ratings⁽¹⁾

Supply Voltage (V_{IN})	-0.3V +6V
Fault Flag Voltage (V_{FLG})	+6V
Fault Flag Current (I_{FLG})	25mA
Output Voltage (V_{OUT})	+6V
Output Current (I_{OUT})	Internally Limited
Enable Input (I_{EN})	-0.3V V_{IN} +3V
Lead Temperature (soldering, 5sec.)	260°C
Storage Temperature (T_S)	-65°C to +150°C
EDS Rating ⁽³⁾	1kV

Operating Ratings⁽²⁾

Supply voltage (V_{IN})	+2.7V to +5.5V
Ambient Temperature (T_A)	-40°C to +85°C
Junction Thermal Range (T_J)	Internally Limited
Thermal Resistance	
[300 mil] Wide SOIC (θ_{JA})	120°C/W
[150 mil] SOIC (θ_{JA})	112°C/W
DIP (θ_{JA})	130°C/W

Electrical Characteristics

$V_{IN} = +5V$; $T_A = 25^\circ C$, **bold** values indicate $-40^\circ C \leq T_A \leq +85^\circ C$, unless noted.

Symbol	Parameter	Condition	Min	Typ	Max	Units
I_{DD}	Supply Current	MIC20x7-1, $V_{ENA-D} \leq 0.8V$ (switch off), OUT = open		1.5	10	μA
		MIC20x7-2, $V_{ENA-D} \geq 2.4V$ (switch off), OUT = open		1.5	10	μA
		MIC20x7-1, $V_{ENA-D} \geq 2.4V$ (switch on), OUT = open		200	320	μA
		MIC20x7-2, $V_{ENA-D} \leq 0.8V$ (switch on), OUT = open		200	320	μA
V_{EN}	Enable Input Threshold	low-to-high transition		1.7	2.4	V
		high-to-low transition	0.8	1.45		V
	Enable Input Hysteresis			250		mV
I_{EN}	Enable Input Current	$V_{EN} = 0V$ to 5.5V	-1	0.01	1	μA
	Enable Input Capacitance			1		pF
$R_{DS(on)}$	Switch Resistance	$V_{IN} = 5V$, $I_{OUT} = 500mA$		100	150	m Ω
		$V_{IN} = 3.3V$, $I_{OUT} = 500mA$		110	180	m Ω
	Output Leakage Current	MIC20x7-1, $V_{ENx} \leq 0.8V$; MIC20x7-2, $V_{ENx} \geq 2.4V$, (output off)			10	μA
	Output Current in Latched Thermal Shutdown	MIC2077 (per Latch Output) (during thermal shutdown state)		50		μA
t_{ON}	Output Turn-On Delay	$R_L = 10\Omega$, $C_L = 1\mu F$, see "Timing Diagrams"		1.3	5	ms
t_R	Output Turn-On Rise Time	$R_L = 10\Omega$, $C_L = 1\mu F$, see "Timing Diagrams"		1.15	4.9	ms
t_{OFF}	Output Turnoff Delay	$R_L = 10\Omega$, $C_L = 1\mu F$, see "Timing Diagrams"		35	100	μs
t_F	Output Turnoff Fall Time	$R_L = 10\Omega$, $C_L = 1\mu F$, see "Timing Diagrams"		32	100	μs
I_{LIMIT}	Short-Circuit Output Current	$V_{OUT} = 0V$, enabled into short-circuit	0.5	0.9	1.25	A
	Current-Limit Threshold	ramped load applied to output		1.0	1.25	A
	Short-Circuit Response Time	$V_{OUT} = 0V$ to $I_{OUT} = I_{LIMIT}$ (short applied to output)		20		μs
t_D	Overcurrent Flag Response Delay	$V_{IN} = 5V$, apply $V_{OUT} = 0V$ until FLG low	1.5	3	7	ms
		$V_{IN} = 3.3V$, apply $V_{OUT} = 0V$ until FLG low		3		ms

Symbol	Parameter	Condition	Min	Typ	Max	Units
	Undervoltage Lockout Threshold	V_{IN} rising	2.2	2.4	2.7	V
		V_{IN} falling	2.0	2.15	2.5	V
	Error Flag Output Resistance	$I_L = 10\text{mA}$, $V_{IN} = 5\text{V}$		10	25	Ω
		$I_L = 10\text{mA}$, $V_{IN} = 3.3\text{V}$		15	40	Ω
	Error Flag Off Current	$V_{FLAG} = 5\text{V}$			10	μA
	Overtemperature Threshold Note 4	T_J increasing, each switch		140		$^{\circ}\text{C}$
		T_J decreasing, each switch		120		$^{\circ}\text{C}$
		T_J increasing, both switches		160		$^{\circ}\text{C}$
		T_J decreasing, both switches		150		$^{\circ}\text{C}$

Notes:

1. Exceeding the absolute maximum rating may damage the device.
2. The device is not guaranteed to function outside its operating rating.
3. Devices are ESD sensitive. Handling precautions recommended. Human body model, 1.5k in series with 100pF.
4. If there is an output current limit fault on one channel, that channel will shut down when the die reaches approximately 140°C. If the die reaches approximately 160°C, the other channel driven by the same input will shut down, even if neither channel is in current limit.

Test Circuit

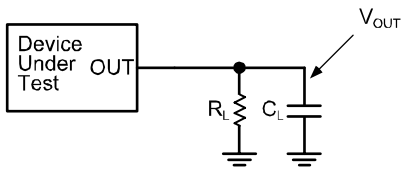

Timing Diagrams

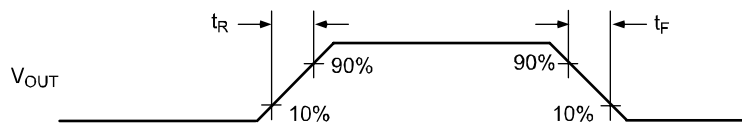

Output Rise and Fall Times

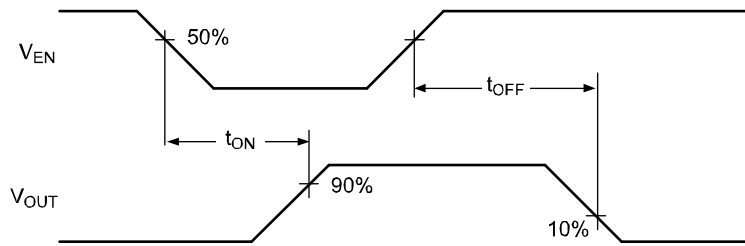

Active-Low Switch Delay Times (MIC20x7-2)

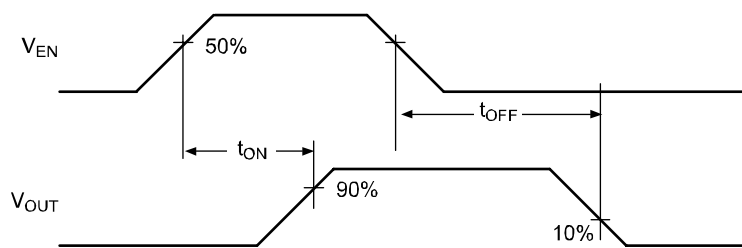

Active-High Switch Delay Times (MIC20x7-1)

Typical Characteristics

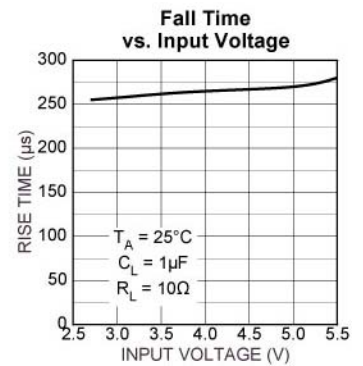
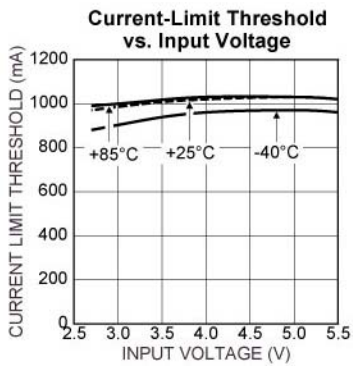
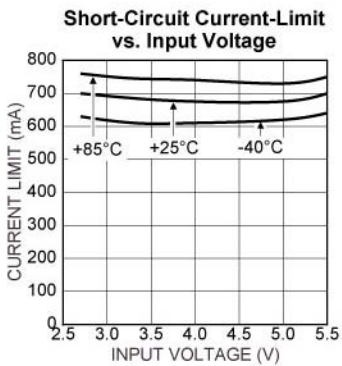
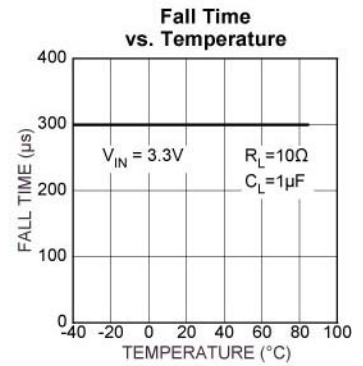
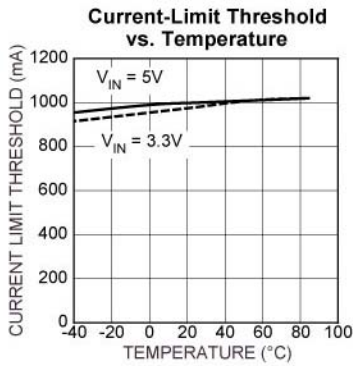
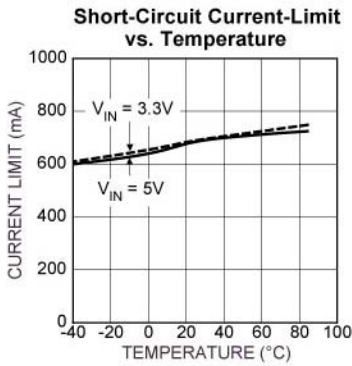
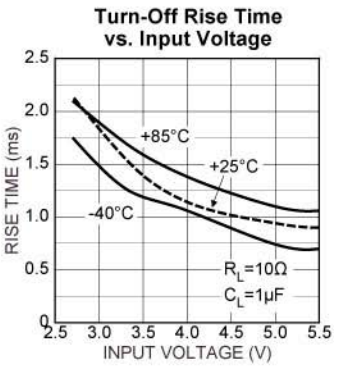
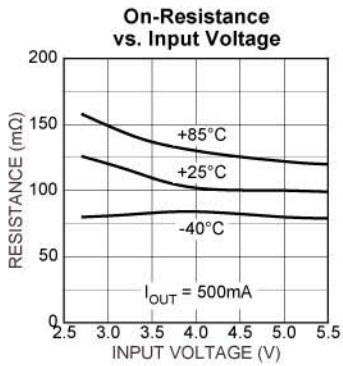
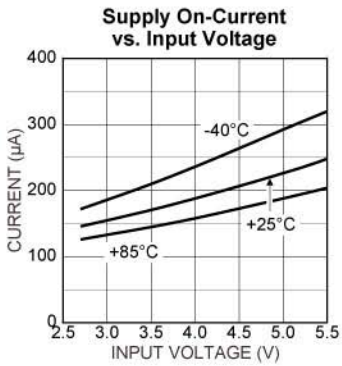
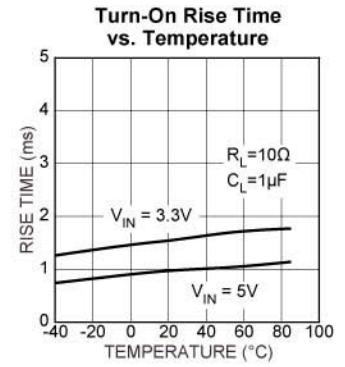
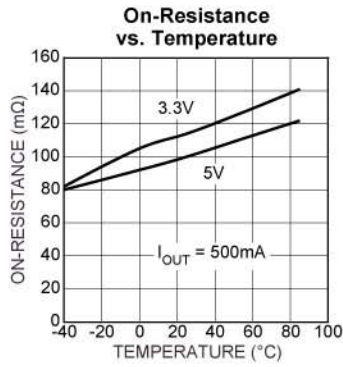
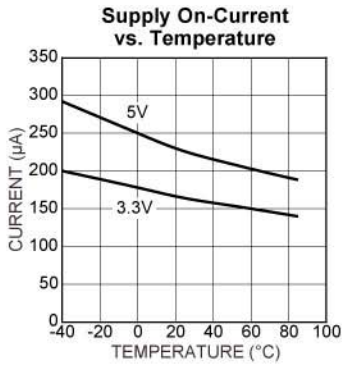

Typical Characteristics (cont.)

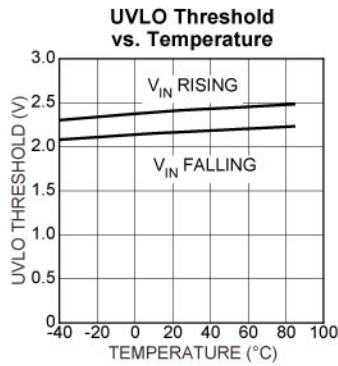
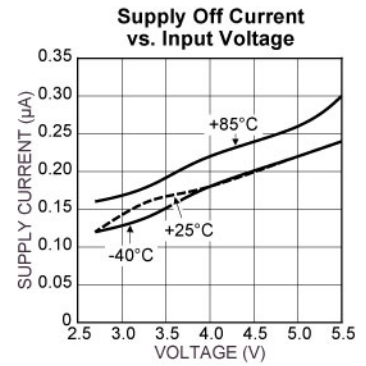
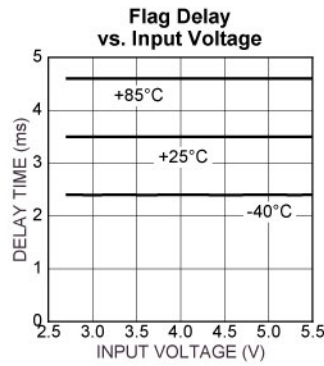
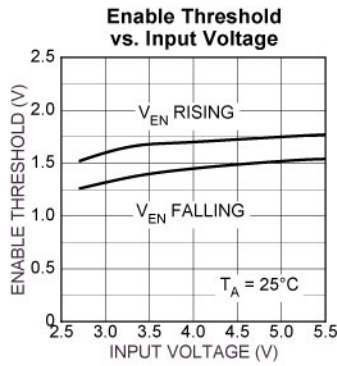
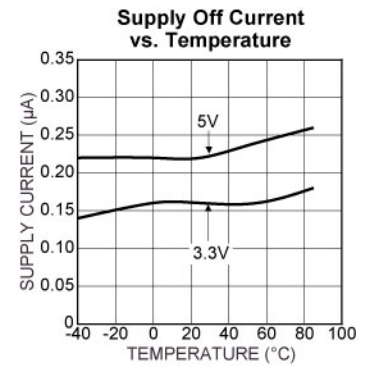
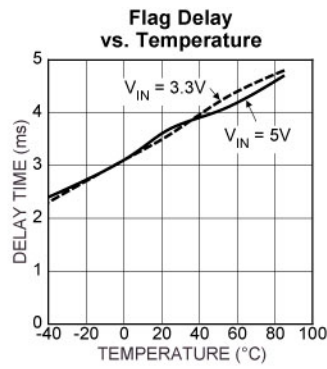
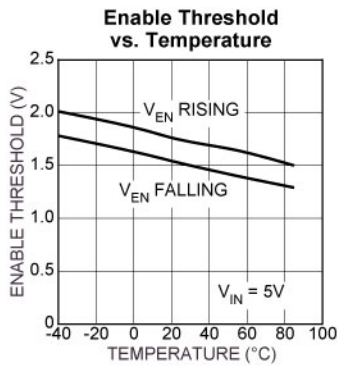

Functional Characteristics

**UVLO— V_{IN} Rising
(MIC2027-1)**

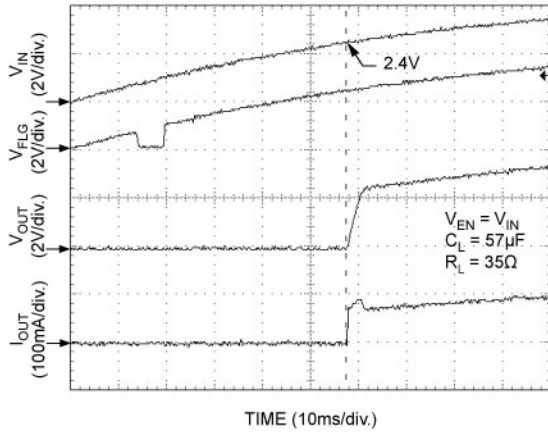

**UVLO— V_{IN} Falling
(MIC2027-1)**

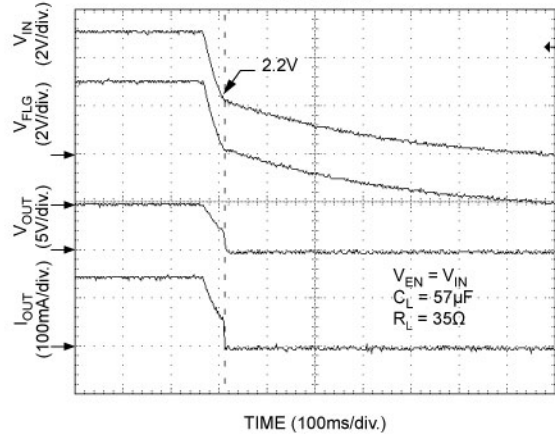

**Turn-On/Turnoff
(MIC2027-1)**

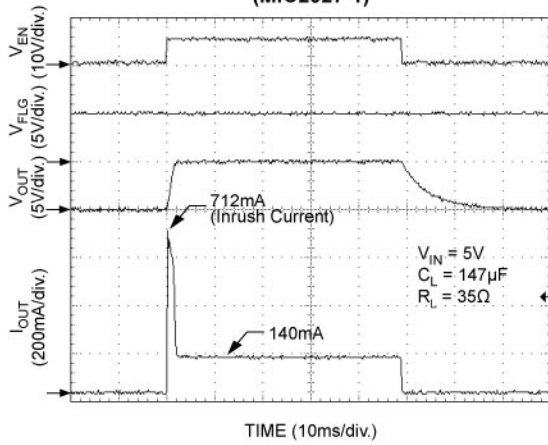

**Turn-On
(MIC2027-1)**

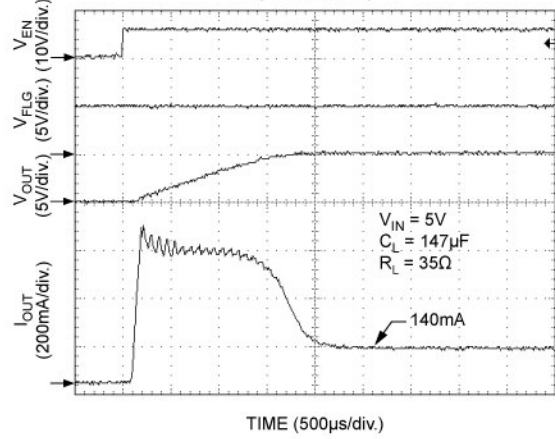

**Turnoff
(MIC2027-1)**

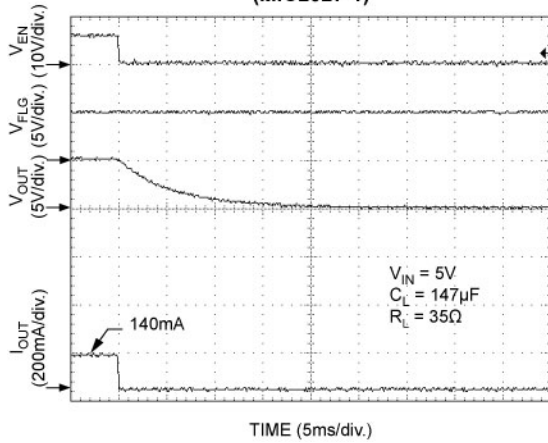

**Enabled Into Short
(MIC2027-1)**

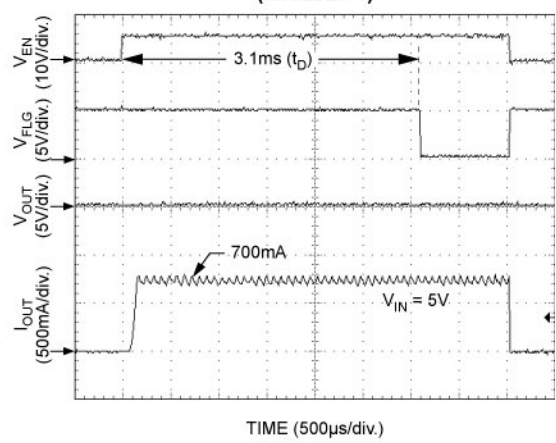

Functional Characteristics (cont.)

Inrush Current Response (MIC2027-1)

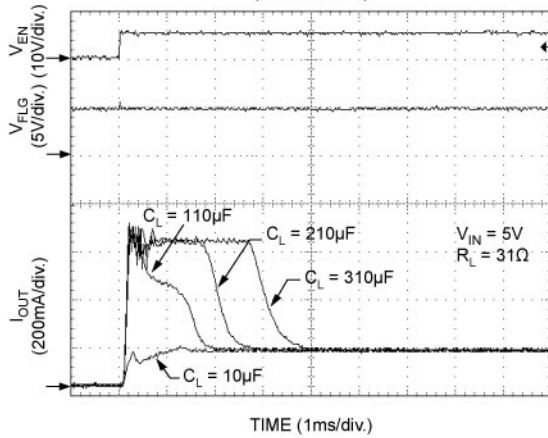

Current-Limit Response (Ramped Load—MIC2027-1)

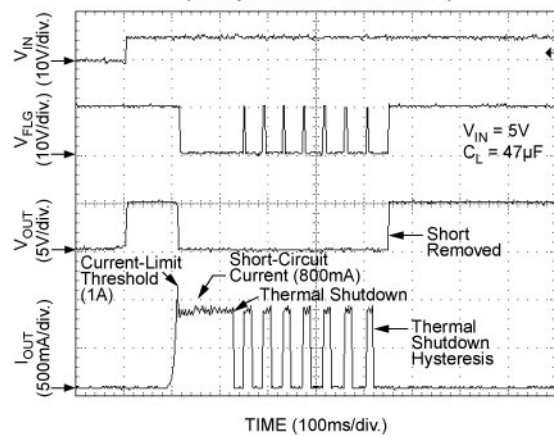

Current-Limit Response (Stepped Short—MIC2027-1)

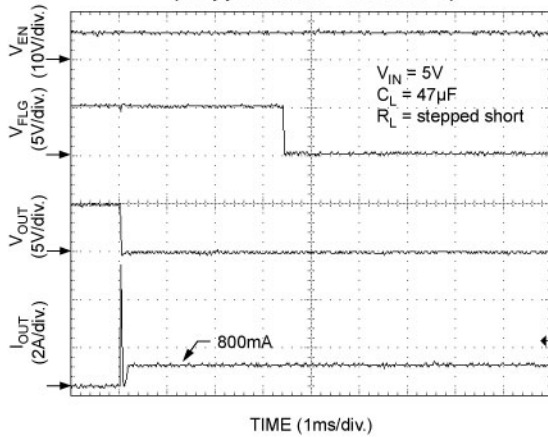

Current-Limit Response (MIC2027-1)

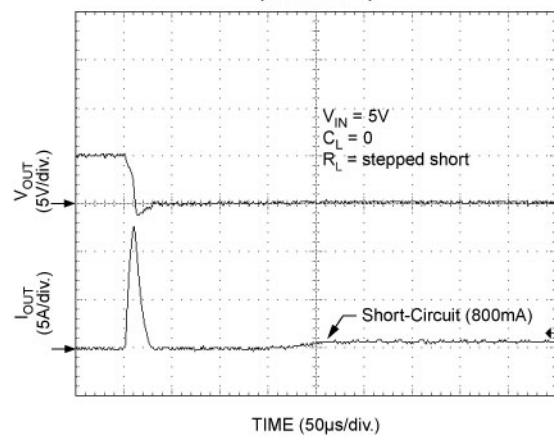

Independent Thermal Shutdown (MIC2027-1)

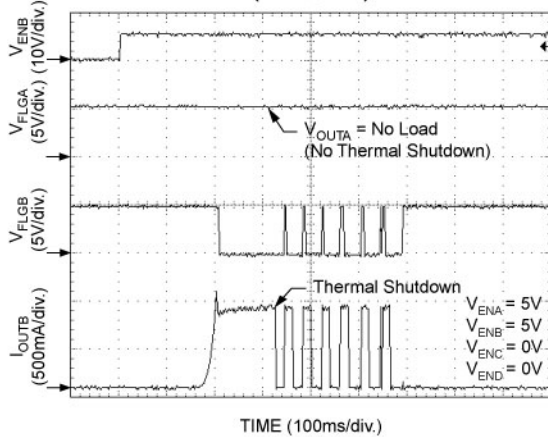

Independent Thermal Shutdown (MIC2027-1)

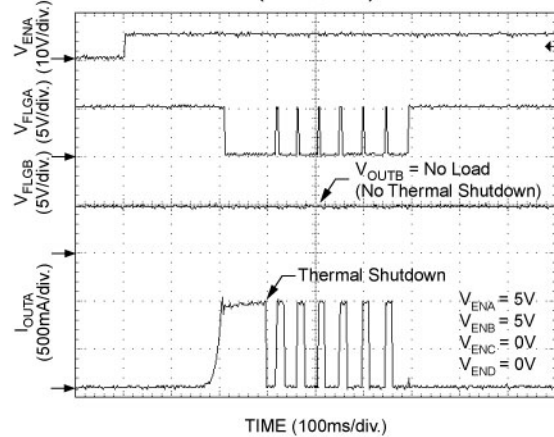

Functional Characteristics (cont.)

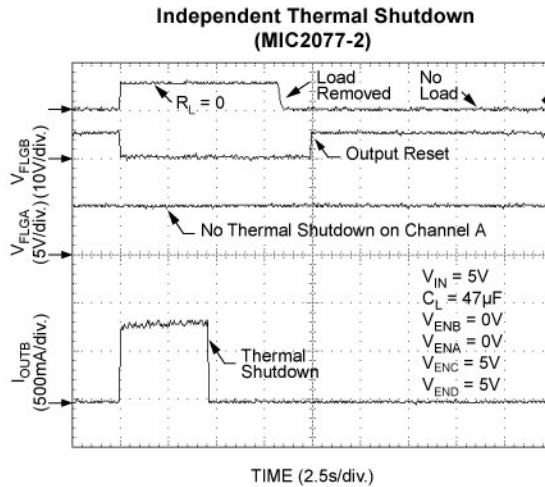
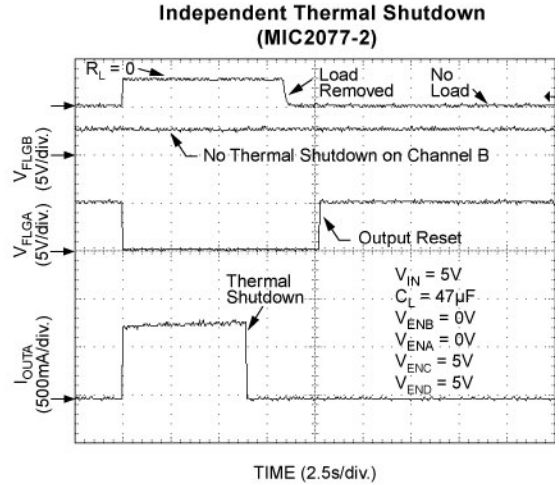
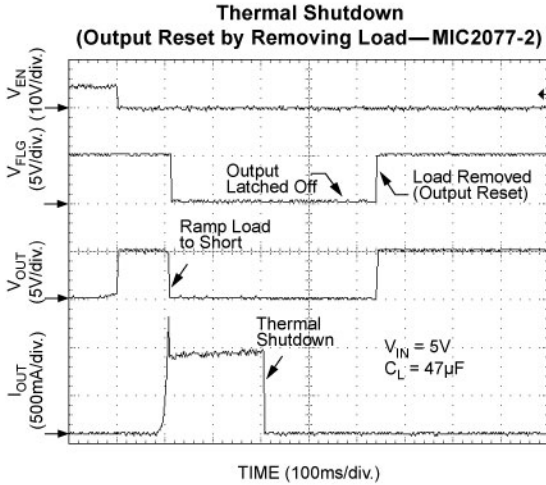
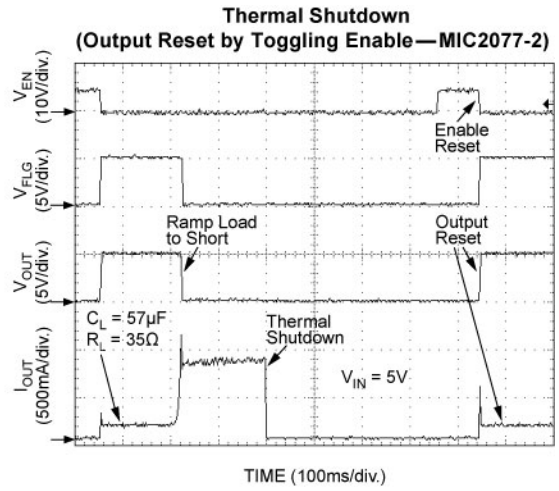
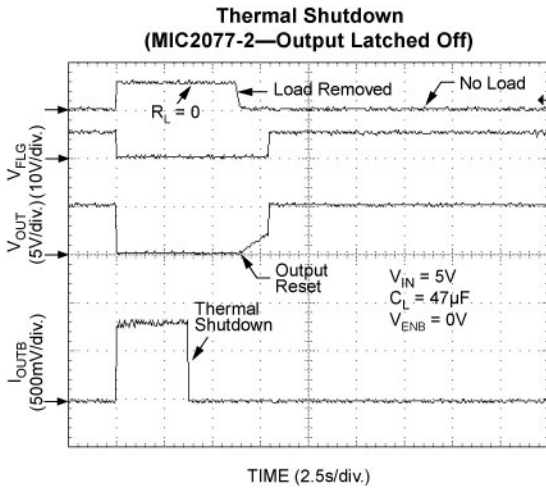

Block Diagram

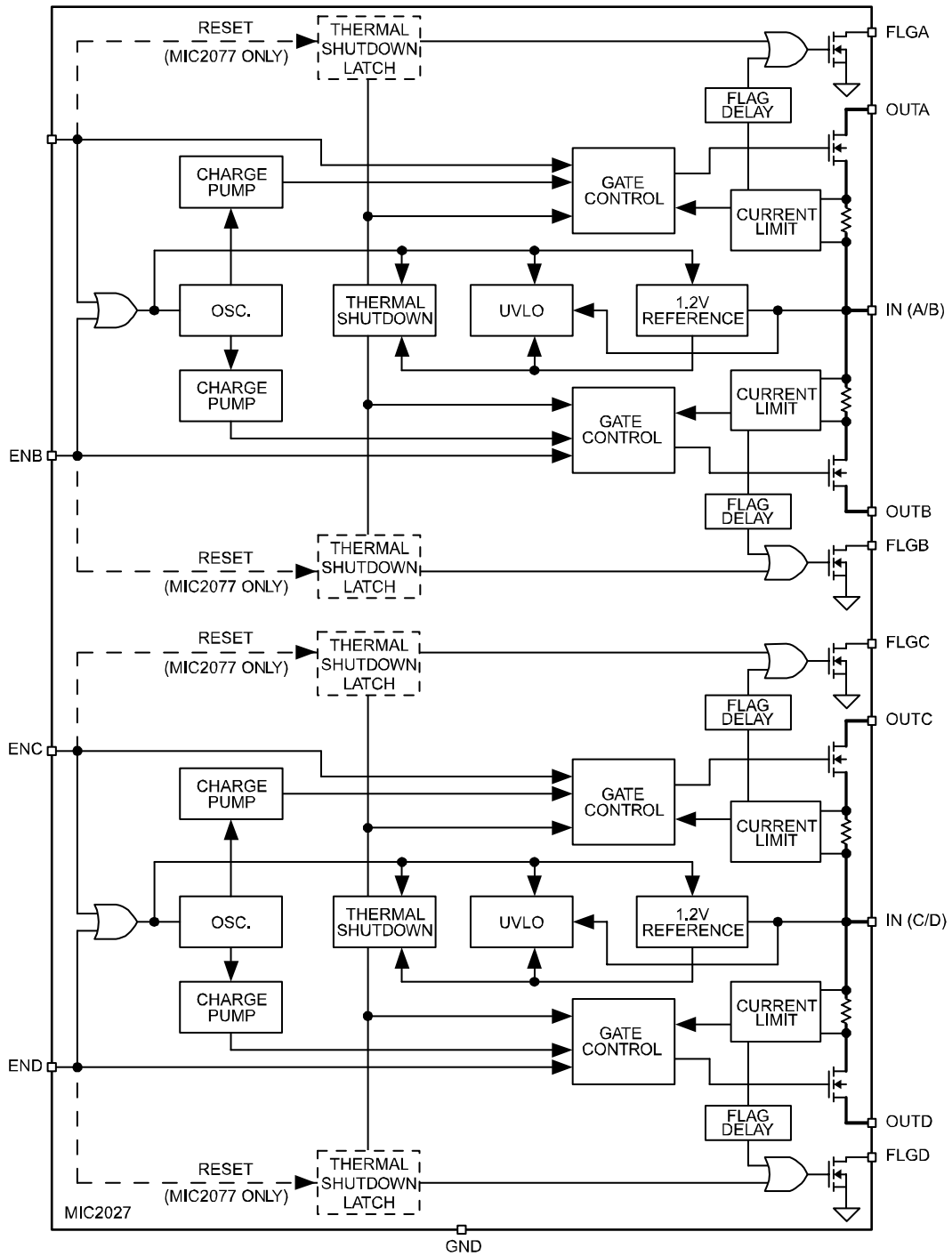

Functional Description

Input and Output

IN is the power supply connection to the logic circuitry and the drain of the output MOSFET. OUT is the source of the output MOSFET. In a typical circuit, current flows from IN to OUT toward the load. If V_{OUT} is greater than V_{IN} , current will flow from OUT to IN, since the switch is bidirectional when enabled. The output MOSFET and driver circuitry are also designed to allow the MOSFET source to be externally forced to a higher voltage than the drain ($V_{OUT} > V_{IN}$) when the switch is disabled. In this situation, the MIC2027/77 prevents undesirable current flow from OUT to IN.

Thermal Shutdown

Thermal shutdown is employed to protect the device from damage should the die temperature exceed safe margins due mainly to short circuit faults. Each channel employs its own thermal sensor. Thermal shutdown shuts off the output MOSFET and asserts the FLG output if the die temperature reaches 140°C and the overheated channel is in current limit. The other channels are not affected. If however, the die temperature exceeds 160°C, all channels will be shut off. Upon determining a thermal shutdown condition, the MIC2077 will latch the output off and activate a pull-up current source. When the load is removed, this current source will pull the output up and reset the latch. Toggling EN will also reset the latch.

The MIC2027 will automatically reset its output when the die temperature cools down to 120°C. The MIC2027 output and FLG signal will continue to cycle on and off until the device is disabled or the fault is removed. Figure 2 depicts typical timing.

Depending on PCB layout, package, ambient temperature, etc., it may take several hundred milliseconds from the incidence of the fault to the output MOSFET being shut off. This time will be shortest in the case of a dead short on the output.

Power Dissipation

The device's junction temperature depends on several factors such as the load, PCB layout, ambient temperature and package type. Equations that can be used to calculate power dissipation of each channel and junction temperature are found below.

$$P_D = R_{DS(on)} \times I_{OUT}^2$$

Total power dissipation of the device will be the summation of P_D for all channels. To relate this to junction temperature, the following equation can be used:

$$T_J = P_D \times \theta_{JA} + T_A$$

where:

T_J = junction temperature

T_A = ambient temperature

θ_{JA} = is the thermal resistance of the package

Current Sensing and Limiting

The current-limit threshold is preset internally. The preset level prevents damage to the device and external load but still allows a minimum current of 500mA to be delivered to the load.

The current-limit circuit senses a portion of the output MOSFET switch current. The current-sense resistor shown in the block diagram is virtual and has no voltage drop. The reaction to an overcurrent condition varies with three scenarios:

Switch Enabled into Short-Circuit

If a switch is enabled into a heavy load or short-circuit, the switch immediately enters into a constant-current mode, limiting the output voltage. The FLG signal is asserted indicating an overcurrent condition.

Short-Circuit Applied to Enabled Output

When a heavy load or short-circuit is applied to an enabled switch, a large transient current may flow until the current-limit circuitry responds. Once this occurs the device limits current to less than the short-circuit current limit specification.

Current-Limit Response—Ramped Load

The MIC2027/77 current-limit profile exhibits a small fold-back effect of about 100mA. Once this current-limit threshold is exceeded the device switches into a constant current mode. It is important to note that the device will supply current up to the current-limit threshold.

Fault Flag

The FLG signal is an N-channel open-drain MOSFET output. FLG is asserted (active-low) when either an overcurrent or thermal shutdown condition occurs. In the case of an overcurrent condition, FLG will be asserted only after the flag response delay time, t_D , has elapsed. This ensures that FLG is asserted only upon valid overcurrent conditions and that erroneous error reporting is eliminated. For example, false overcurrent conditions can occur during hot-plug events when a highly capacitive load is connected and causes a high transient inrush current that exceeds the current-limit threshold. The FLG response delay time t_D is typically 3ms.

Undervoltage Lockout

Undervoltage lockout (UVLO) prevents the output MOSFET from turning on until V_{IN} exceeds approximately 2.5V. Undervoltage detection functions only when the switch is enabled.

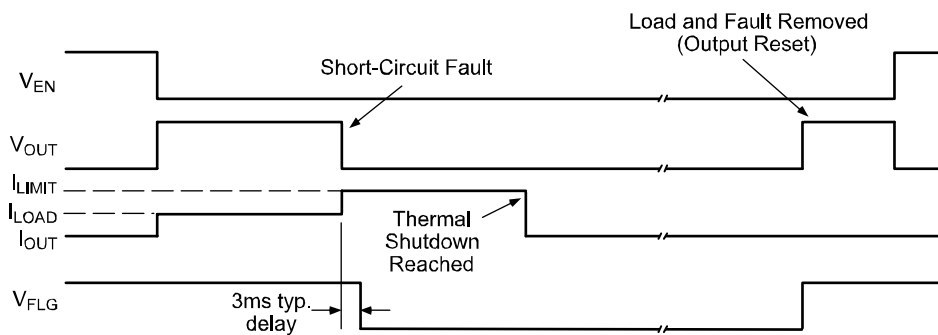

Figure 1. MIC2077-2 Fault Timing: Output Reset by Removing Load

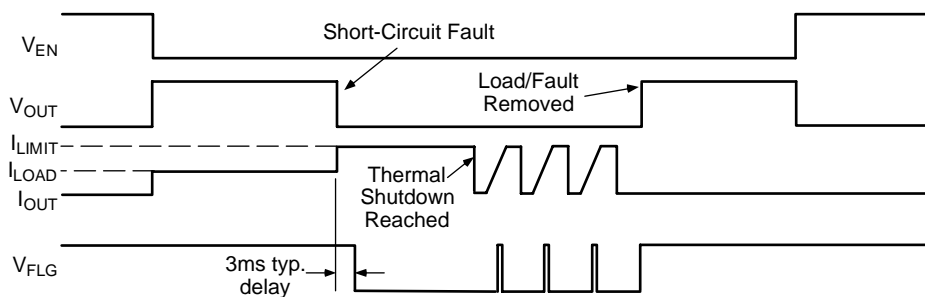

Figure 2. MIC2207-2 Fault Timing

Application Information

Supply Filtering

A 0.1 μ F to 1 μ F bypass capacitor positioned close to V_{IN} and GND of the device is strongly recommended to control supply transients. Without a bypass capacitor, an output short may cause sufficient ringing on the input (from supply lead inductance) to damage internal control circuitry.

Printed Circuit Board Hot-Plug

The MIC2027/77 are ideal inrush current-limiters for hot-plug applications. Due to the integrated charge pump, the MIC2027/77 present a high impedance when off and slowly becomes a low impedance as it turns on. This "soft-start" feature effectively isolates power supplies from highly capacitive loads by reducing inrush current.

In cases of extremely large capacitive loads (>400 μ F), the length of the transient due to inrush current may exceed the delay provided by the integrated filter. Since this inrush current exceeds the current-limit flag delay specification, FLG will be asserted during this time. To prevent the logic controller from responding to FLG

being asserted, an external RC filter, as shown in Figure 3, can be used to filter out transient FLG assertion. The value of the RC time constant should be selected to match the length of the transient, less $t_{D(min)}$ of the MIC2027/77.

Universal Serial Bus (USB) Power Distribution

The MIC2027/77 is ideally suited for USB (Universal Serial Bus) power distribution applications. The USB specification defines power distribution for USB host systems such as PCs and USB hubs. Hubs can either be self-powered or bus-powered (that is, powered from the bus). The requirement for USB self-powered hubs is that the port must supply a minimum of 500mA at an output voltage of 5V \pm 5%. In addition, the output power delivered must be limited to below 25VA. Upon an overcurrent condition, the host must also be notified. To support hot-plug events, the hub must have a minimum of 120 μ F of bulk capacitance, preferably low ESR electrolytic or tantalum. Please refer to Application Note 17 for more details on designing compliant USB hub and host systems.

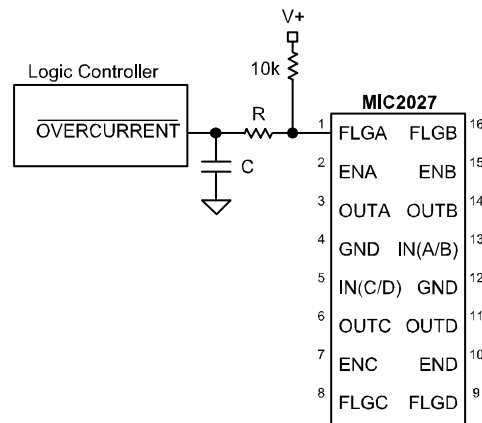
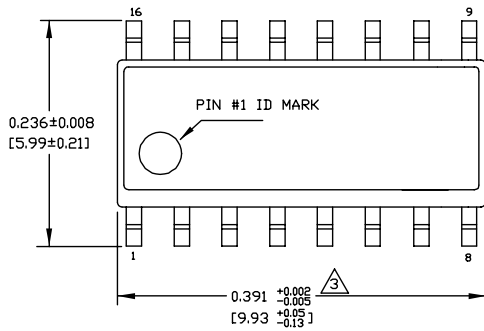
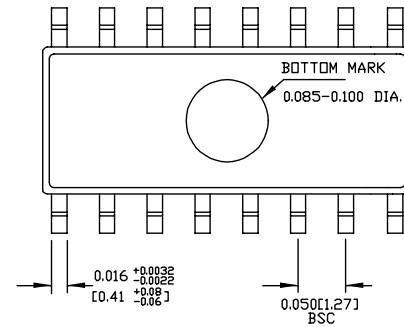

Figure 3. Transient Filter

Package Information



TOP VIEW



BOTTOM VIEW

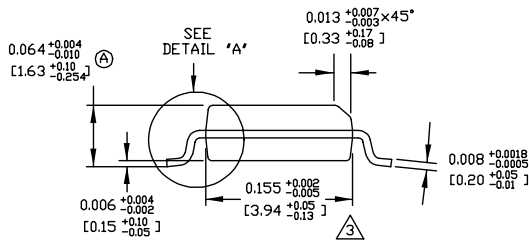

END VIEW

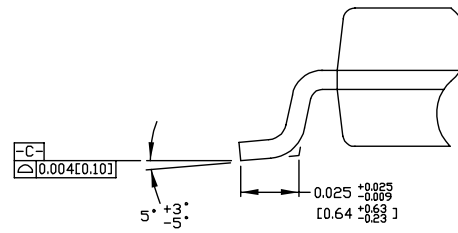

DETAIL "A"

NOTES:

1. DIMENSIONS ARE IN INCHES[MM].
2. CONTROLLING DIMENSION: INCHES.
3. DIMENSION DOES NOT INCLUDE MOLD FLASH OR PROTRUSIONS, EITHER OF WHICH SHALL NOT EXCEED 0.010[0.25] PER SIDE.

16-Pin SOIC (M)

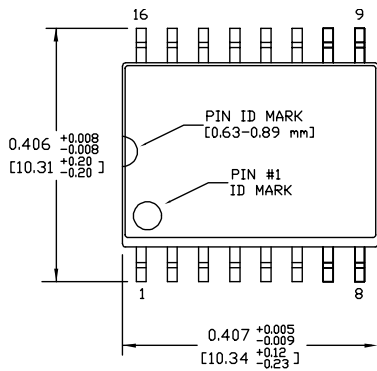

TOP VIEW

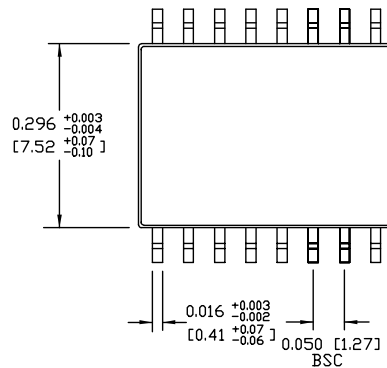

BOTTOM VIEW

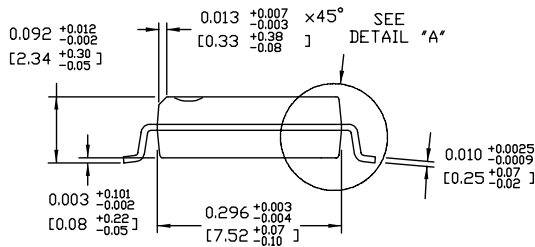

END VIEW

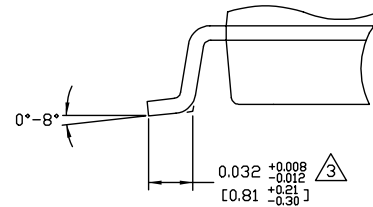

DETAIL "A"

NOTES:

1. DIMENSIONS ARE IN INCHES[MM].
2. CONTROLLING DIMENSION: INCHES.
3. DIMENSION DOES NOT INCLUDE MOLD FLASH OR PROTRUSIONS, EITHER OF WHICH SHALL NOT EXCEED 0.006[0.15] PER SIDE.

16-Pin Wide SOIC (WM)

MICREL, INC. 2180 FORTUNE DRIVE SAN JOSE, CA 95131 USA
 TEL +1 (408) 944-0800 FAX +1 (408) 474-1000 WEB <http://www.micrel.com>

The information furnished by Micrel in this data sheet is believed to be accurate and reliable. However, no responsibility is assumed by Micrel for its use. Micrel reserves the right to change circuitry and specifications at any time without notification to the customer.

Micrel Products are not designed or authorized for use as components in life support appliances, devices or systems where malfunction of a product can reasonably be expected to result in personal injury. Life support devices or systems are devices or systems that (a) are intended for surgical implant into the body or (b) support or sustain life, and whose failure to perform can be reasonably expected to result in a significant injury to the user. A Purchaser's use or sale of Micrel Products for use in life support appliances, devices or systems is a Purchaser's own risk and Purchaser agrees to fully indemnify Micrel for any damages resulting from such use or sale.

© 2001 Micrel, Incorporated.

Looking for pricing, stock, or lifecycle information?

Click below to explore more details on WIN SOURCE:

- ⊖ [View MIC2027-1YM on WIN SOURCE](#)
- ⊖ [Microchip Technology Information](#)

Optimize Your Supply Chain with WIN SOURCE Solutions

- ✓ Global Sourcing Solution
- ✓ Obsolete Management
- ✓ Cost Control Management
- ✓ Shortage Management
- ✓ Alternative Solution
- ✓ Excess Inventory Management