

## High-Speed 4-Channel MOSFET Driver with Two Inverting and Two Non-Inverting Outputs

### Features

- Mixed Inversion MOSFET Driver
- 6 ns Rise and Fall Time
- 2A Peak Output Source-and-Sink Current
- 1.8V to 5V Input CMOS Compatible
- 5V to 10V Total Supply Voltage
- Smart Logic Threshold
- Low-Jitter Design
- Four Matched Channels
- Drives Two P-Channel and Two N-Channel MOSFETs
- Outputs can swing below Ground
- Low-Inductance, Quad-Flat No-Lead Package
- High-Performance, Thermally Enhanced Packaging

### Applications

- Medical Ultrasound Imaging
- Piezoelectric Transducer Drivers
- Non-Destructive Testing
- PIN Diode Driver
- CCD Clock Driver/Buffer
- High-Speed Level Translator

### General Description

The MD1822 is a high-speed, four-channel MOSFET driver designed to drive high-voltage P-channel and N-channel MOSFETs for medical ultrasound applications and other applications requiring a high-output current for a capacitive load. The high-speed input stage of the MD1822 can operate from a 1.8V to 5V logic interface with an optimum operating input signal range of 1.8V to 3.3V. An adaptive threshold circuit is used to set the level translator switch threshold to the average of the input logic 0 and logic 1 levels. The input logic levels may be ground referenced even though the driver is putting out bipolar signals. The level translator uses a proprietary circuit, which provides DC coupling together with high-speed operation.

The output stage of the MD1822 has separate power connections, enabling the output signal L and H levels to be chosen independently from the supply voltages used for the majority of the circuit. As an example, the input logic levels may be 0V and 1.8V, the control logic may be powered by +5V and -5V, and the output L and H levels may be varied anywhere over the range of -5V to +5V. The output stage is capable of peak currents of up to  $\pm 2A$ , depending on the supply voltages used and load capacitance present. The PE pin serves a dual purpose. First, its logic H level is used to compute the threshold voltage level for the channel input level translators. (See [Figure 3-1](#).) Second, when PE is low, the outputs are disabled, with the A and C outputs high and the B and D outputs low. This assists in properly precharging the AC coupling capacitors that may be used in series in the gate drive circuit of an external PMOS and NMOS transistor pair.

### Package Type

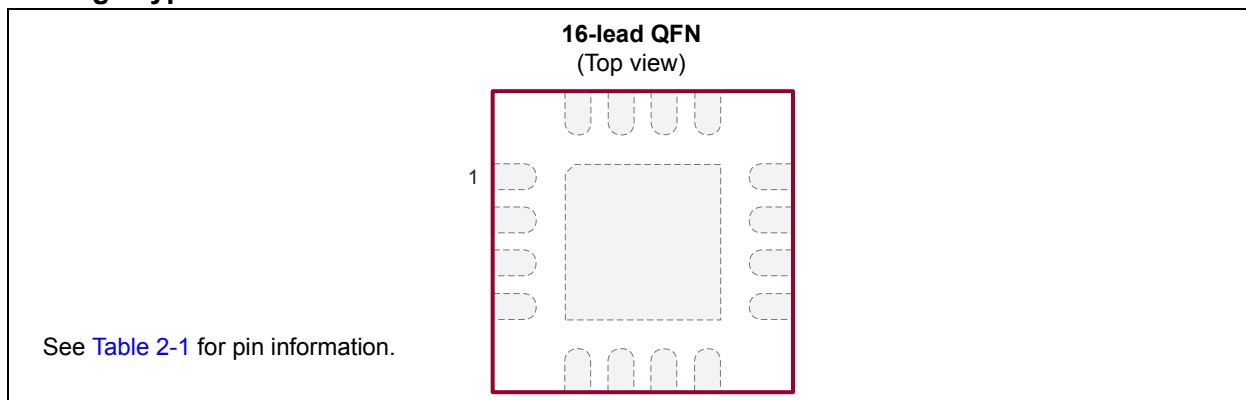

# MD1822

## Functional Block Diagrams

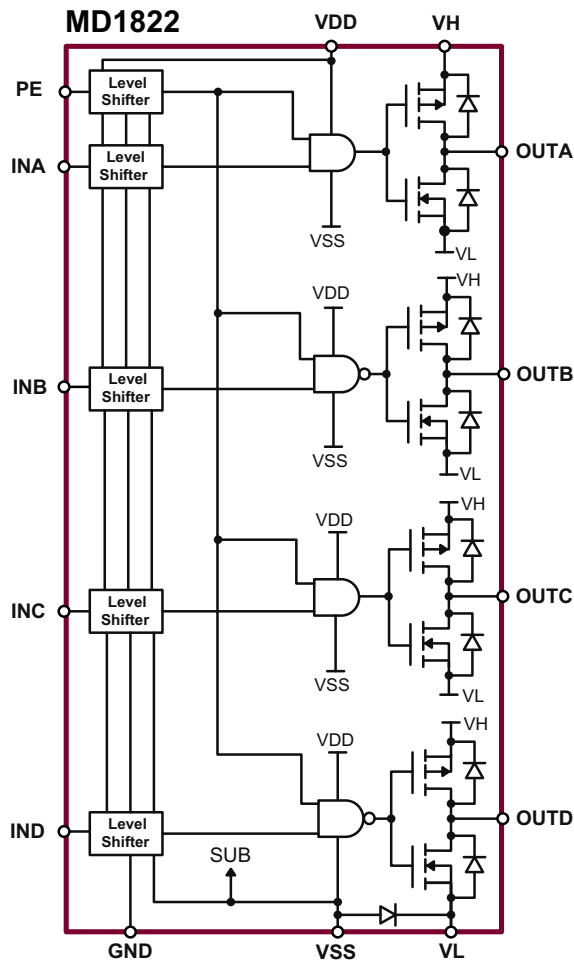
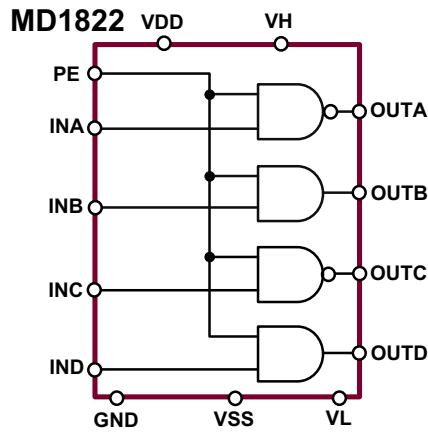

## Typical Application Circuit

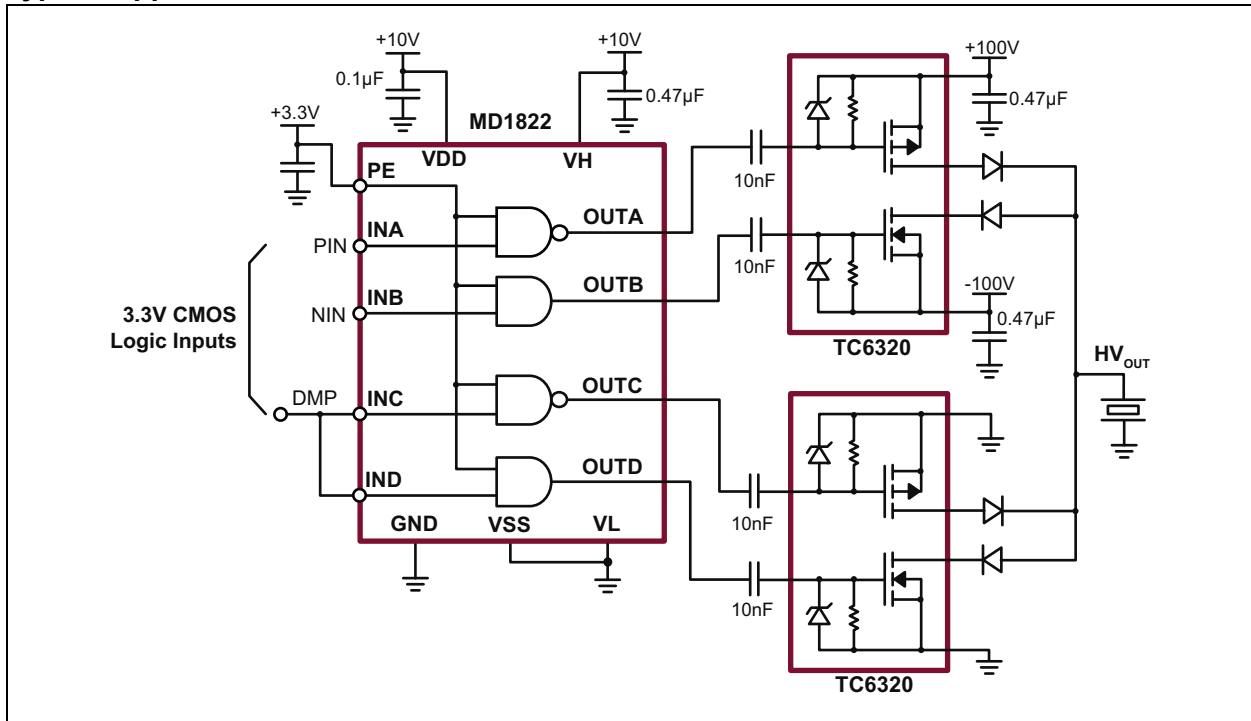

# MD1822

## 1.0 ELECTRICAL CHARACTERISTICS

### Absolute Maximum Ratings†

Logic Supply Voltage, $V_{DD}-V_{SS}$	-0.5V to +12.5V
Output High Supply Voltage, $V_H$	$V_L-0.5V$ to $V_{DD}+0.5V$
Output Low Supply Voltage, $V_L$	$V_{SS}-0.5V$ to $V_H+0.5V$
Low-Side Supply Voltage, $V_{SS}$	-6V to +0.5V
Logic Input Levels	$V_{SS}-0.5V$ to GND +5.5V
Maximum Junction Temperature, $T_J$	+125°C
Operating Ambient Temperature, $T_A$	-20°C to +85°C
Storage Temperature, $T_S$	-65°C to +150°C
Power Dissipation (Thermal Resistance, $\theta_{JA} = 55$ °C/W) (Note 2):	
16-lead QFN	2.2W
ESD Rating (Note 1)	ESD Sensitive

† **Notice:** Stresses above those listed under “Absolute Maximum Ratings” may cause permanent damage to the device. This is a stress rating only, and functional operation of the device at those or any other conditions above those indicated in the operational sections of this specification is not intended. Exposure to maximum rating conditions for extended periods may affect device reliability.

**Note 1:** Device is ESD sensitive. Handling precautions are recommended.

**2:** Mounted on a 1 oz. four-layer 3” x 4” PCB

### DC ELECTRICAL CHARACTERISTICS

Electrical Specifications: $V_H = V_{DD} = 10V$ , $V_L = V_{SS} = GND = 0V$ , $V_{PE} = 3.3V$ , $T_A = 25^\circ C$						
Parameter	Sym.	Min.	Typ.	Max.	Unit	Conditions
Logic Supply Voltage	$V_{DD}-V_{SS}$	4.75	—	11.5	V	$4V \leq V_{DD} \leq 11.5V$
Low-Side Supply Voltage	$V_{SS}$	-5.5	—	0	V	
Output High Supply Voltage	$V_H$	$V_{SS}+2$	—	$V_{DD}$	V	
Output Low Supply Voltage	$V_L$	$V_{SS}$	—	$V_{DD}-4$	V	
$V_{DD}$ Quiescent Current	$I_{DDQ}$	—	60	—	$\mu A$	No input transitions, PE = 0
$V_H$ Quiescent Current	$I_{HQ}$	—	2	—	$\mu A$	
$V_{DD}$ Quiescent Current	$I_{DDQ}$	—	1	—	mA	No input transitions, PE = 1
$V_H$ Quiescent Current	$I_{HQ}$	—	2	—	$\mu A$	
$V_{DD}$ Average Current	$I_{DD}$	—	4	—	mA	One channel on at 5 MHz, no load
$V_H$ Average Current	$I_H$	—	10	—	mA	
Input Logic Voltage High	$V_{IH}$	$V_{PE}-0.3$	—	$V_{PE}$	V	For logic inputs INA, INB, INC, and IND
Input Logic Voltage Low	$V_{IL}$	0	—	0.3	V	
Input Logic Current High	$I_{IH}$	—	—	1	$\mu A$	
Input Logic Current Low	$I_{IL}$	—	—	1	$\mu A$	
PE Input logic Voltage High	$V_{IH}$	1.7	3.3	5.25	V	For logic input PE
PE Input Logic Voltage Low	$V_{IL}$	0	—	0.3	V	
PE Input Impedance to GND	$R_{IN\_PE}$	100	—	—	k $\Omega$	
Logic Input Capacitance	$C_{IN}$	—	5	10	pF	$I_{SINK} = 50$ mA
Output Sink Resistance	$R_{SINK}$	—	1.5	—	$\Omega$	$I_{SOURCE} = 50$ mA
Output Source Resistance	$R_{SOURCE}$	—	2	—	$\Omega$	
Peak Output Sink Current	$I_{SINK}$	—	2	—	A	
Peak Output Source Current	$I_{SOURCE}$	—	2	—	A	

## AC ELECTRICAL CHARACTERISTICS

**Electrical Specifications:**  $V_H = V_{DD} = 10V$ ,  $V_L = V_{SS} = GND = 0V$ ,  $V_{PE} = 3.3V$ ,  $T_A = 25^\circ C$  unless otherwise indicated.

Parameter	Sym.	Min.	Typ.	Max.	Unit	Conditions
Input or PE Rise and Fall Time	$t_{irf}$	—	—	10	ns	Logic input edge speed requirement
Propagation Delay when Output is from Low to High	$t_{PLH}$	—	6.5	—	ns	$C_{LOAD} = 1000$ pF (see <a href="#">Timing Diagram</a> ), input signal rise/fall time 2 ns
Propagation Delay when Output is from High to Low	$t_{PHL}$	—	6.5	—	ns	
Output Rise Time	$t_r$	—	7	—	ns	
Output Fall Time	$t_f$	—	7	—	ns	
Rise and Fall Time Matching	$ t_r - t_f $	—	1	—	ns	
Propagation Low to High and High to Low Matching	$ t_{PLH} - t_{PHL} $	—	1	—	ns	For each channel
Propagation Delay Matching	$\Delta t_{dm}$	—	$\pm 2$	—	ns	Device to device delay match
PE On Time	$t_{PE-ON}$	—	—	5	$\mu s$	$V_{PE} = 1.7V-5.25V$ , $V_{DD} = 7.5V-11.5V$ , $-20^\circ C-85^\circ C$
PE Off-Time	$t_{PE-OFF}$	—	—	4	$\mu s$	

## TEMPERATURE SPECIFICATIONS

Parameter	Sym.	Min.	Typ.	Max.	Units	Conditions
<b>TEMPERATURE RANGE</b>						
Maximum Junction Temperature	$T_J$	—	—	+125	$^\circ C$	
Operating Ambient Temperature	$T_A$	-20	—	+85	$^\circ C$	
Storage Temperature	$T_S$	-65	—	+150	$^\circ C$	
<b>PACKAGE THERMAL RESISTANCE</b>						
16-lead QFN	$\theta_{JA}$	—	55	—	$^\circ C/W$	

# MD1822

## Timing Diagram

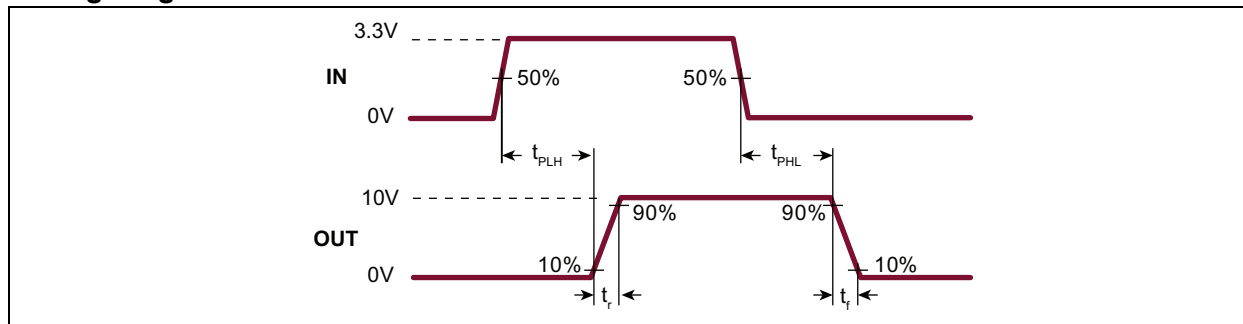

TABLE 1-1: TRUTH FUNCTION TABLE

Logic Input			Output	
PE	INA	INB	OUTA	OUTB
H	L	H	$V_H$	$V_H$
H	L	L	$V_H$	$V_L$
H	H	H	$V_L$	$V_H$
H	H	L	$V_L$	$V_L$
L	X	X	$V_H$	$V_L$
PE	INC	IND	OUTC	OUTD
H	L	H	$V_H$	$V_H$
H	L	L	$V_H$	$V_L$
H	H	H	$V_L$	$V_H$
H	H	L	$V_L$	$V_L$
L	X	X	$V_H$	$V_L$

## 2.0 PIN DESCRIPTION

The details on the pins of MD1822 are listed on [Table 2-1](#). See [Package Type](#) for the location of pins.

**TABLE 2-1: PIN FUNCTION TABLE**

Pin Number	Pin Name	Description
1	INB	Logic input
2	VDD	High-side supply voltage
3	VSS	Low-side supply voltage. VSS is also connected to the IC substrate. It is required to connect to the most negative potential of voltage supplies.
4	INC	Logic input
5	IND	Logic input
6	GND	Logic input ground reference
7	VL	Supply voltage for N-channel output stage
8	OUTC	Output driver
9	OUTD	Output driver
10, 11	VH	Supply voltage for P-channel output stage
12	OUTA	Output driver
13	OUTB	Output driver
14	VL	Supply voltage for N-channel output stage
15	PE	Power enable logic input. When PE is high, it sets the input logic threshold. When PE is low, all outputs are at default state (See <a href="#">Table 1-1</a> .) and the IC is in Standby mode.
16	INA	Logic input
Substrate		The IC substrate is internally connected to the thermal pad. The thermal pad and VSS must be connected externally.

# MD1822

## 3.0 APPLICATION INFORMATION

For proper operation of the MD1822, low-inductance bypass capacitors should be used on the various supply pins. The GND pin should be connected to the logic ground. The INA, INB, INC, IND and PE pins should be connected to a logic source with a swing of GND to PE, where PE is from 1.8V to 5V. Good trace practices should be followed corresponding to the desired operating speed. The internal circuitry of the MD1822 is capable of operating up to 100 MHz, with the primary speed limitation being the loading effects of the load capacitance. Because of this speed and the high transient currents that result in capacitive loads, the bypass capacitors should be as close to the chip pins as possible. Unless the load specifically requires bipolar drive, the  $V_{SS}$  and  $V_L$  pins should have low-inductance feed-through connections directly to a ground plane. If these voltages are not zero, then they need bypass capacitors in a manner similar to the positive power supplies. The power connection  $V_{DD}$  should have a ceramic bypass capacitor to the ground plane with short leads and decoupling components to prevent resonance in the powerleads.

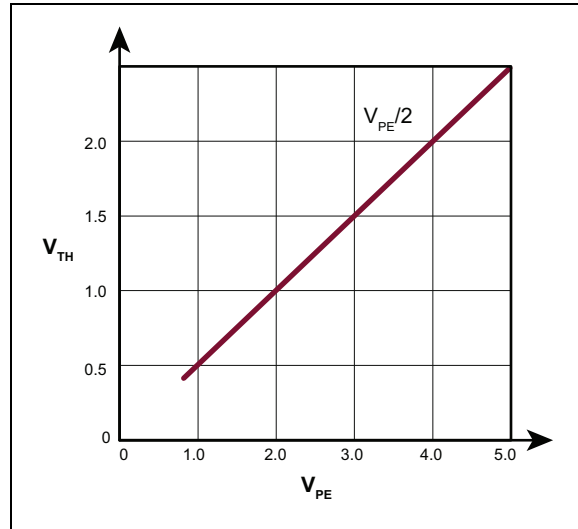

FIGURE 3-1: VTH/VPE Graph.

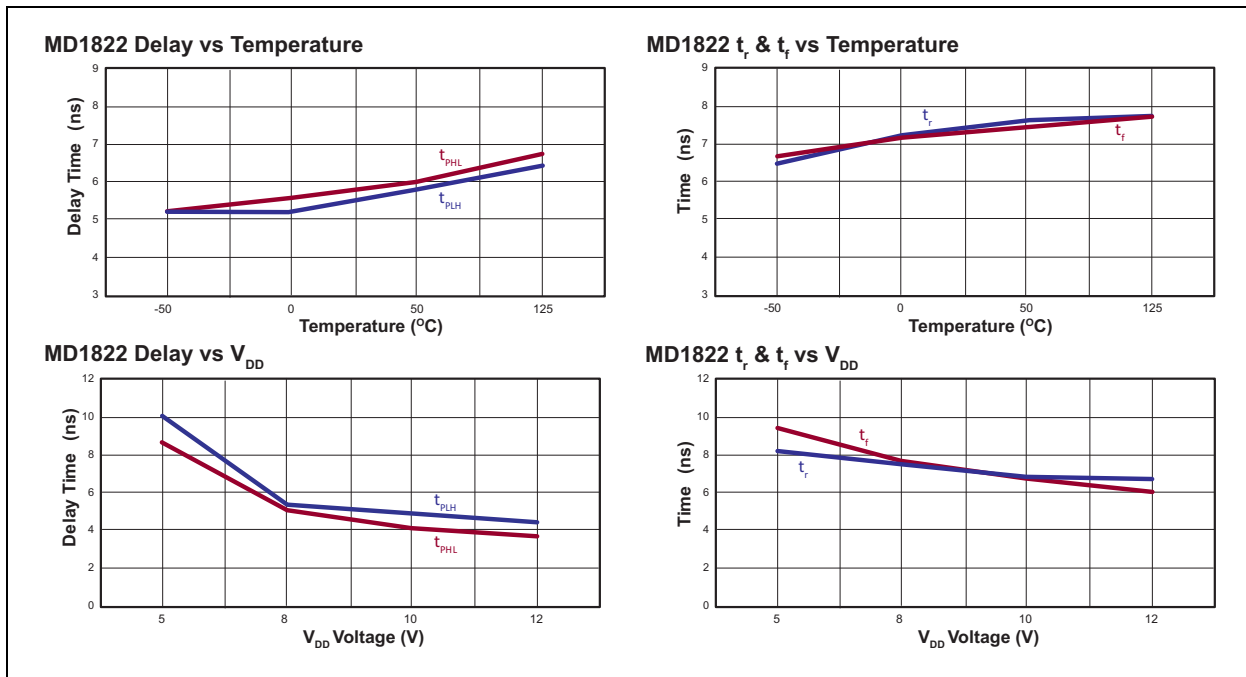

FIGURE 3-2: Rise/Fall times, propagation delay vs. VDD voltage and Temperature.

The voltages of  $V_H$  and  $V_L$  decide the output signal levels. These two pins can draw fast transient currents of up to 2A, so they should be provided with an appropriate bypass capacitor located next to the chip pins. A ceramic capacitor of up to 1  $\mu$ F may be appropriate, with a series ferrite bead to prevent resonance in the power supply lead coming to the capacitor. Pay particular attention to minimizing trace lengths, current loop area and using sufficient trace

width to reduce inductance. Surface-mount components are highly recommended. Since the output impedance of this driver is very low, in some cases, it may be desirable to add a small series resistance in series with the output signal to obtain better waveform transitions at the load terminals. This will reduce the output voltage slew rate at the terminals of a capacitive load.

Make sure that parasitic couplings are minimized from the output to the input signal terminals. The parasitic feedback may cause oscillations or spurious waveform shapes on the edges of signal transitions. Since the input operates with signals down to 1.8V, even small coupled voltages may cause problems. The use of a solid ground plane and good power and signal layout practices will prevent this problem. Be careful that a circulating ground return current from a capacitive load cannot react with common inductance to cause noise voltages in the input logic circuitry.

# MD1822

---

## 4.0 PACKAGING INFORMATION

### 4.1 Package Marking Information

16-lead QFN

Example

XXXXX
XYWW
NNN

182
2815
232

<b>Legend:</b>	XX...X	Product Code or Customer-specific information
	Y	Year code (last digit of calendar year)
	YY	Year code (last 2 digits of calendar year)
	WW	Week code (week of January 1 is week '01')
	NNN	Alphanumeric traceability code
	(e3)	Pb-free JEDEC® designator for Matte Tin (Sn)
	*	This package is Pb-free. The Pb-free JEDEC designator (e3) can be found on the outer packaging for this package.
<b>Note:</b>	In the event the full Microchip part number cannot be marked on one line, it will be carried over to the next line, thus limiting the number of available characters for product code or customer-specific information. Package may or not include the corporate logo.	

## 16-Lead QFN Package Outline (K6) 3.00x3.00mm body, 1.00mm height (max), 0.50mm pitch

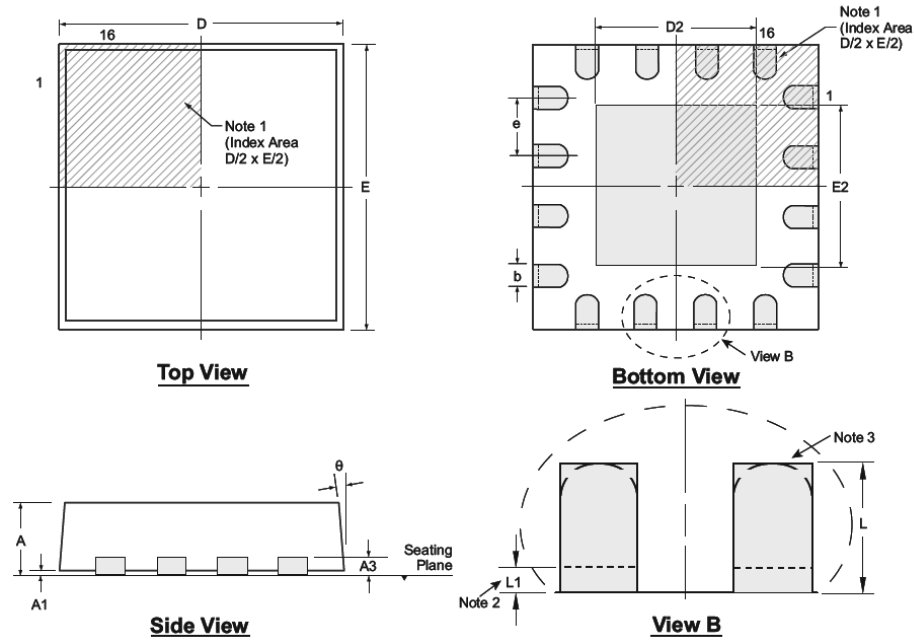

Note: For the most current package drawings, see the Microchip Packaging Specification at [www.microchip.com/packaging](http://www.microchip.com/packaging).

**Notes:**

1. A Pin 1 identifier must be located in the index area indicated. The Pin 1 identifier can be: a molded mark/identifier; an embedded metal marker; or a printed indicator.
2. Depending on the method of manufacturing, a maximum of 0.15mm pullback ( $L1$ ) may be present.
3. The inner tip of the lead may be either rounded or square.

Symbol	A	A1	A3	b	D	D2	E	E2	e	L	L1	$\theta$	
Dimension (mm)	MIN	0.80	0.00	0.20 REF	0.18	2.85*	1.50	2.85*	1.50	0.50 BSC	0.20†	0.00	0°
	NOM	0.90	0.02		0.25	3.00	1.65	3.00	1.65		0.30†	-	-
	MAX	1.00	0.05		0.30	3.15*	1.80	3.15*	1.80		0.45	0.15	14°

JEDEC Registration MO-220, Variation VEED-4, Issue K, June 2006.

\* This dimension is not specified in the JEDEC drawing.

† This dimension differs from the JEDEC drawing.

Drawings not to scale.

# MD1822

---

NOTES:

## APPENDIX A: REVISION HISTORY

### Revision A (October 2018)

- Converted Supertex Doc# DSFP-MD1822 to Microchip DS20005706A
- Changed the package marking format
- Changed the quantity of the K6 package from 3000/Reel to 3300/Reel
- Made minor text changes throughout the document

# MD1822

## PRODUCT IDENTIFICATION SYSTEM

To order or obtain information, e.g., on pricing or delivery, contact your local Microchip representative or sales office.

<u>PART NO.</u>	<u>XX</u>	-	<u>X</u>	-	<u>X</u>
Device	Package Options		Environmental		Media Type
Device:	MD1822	=	High-Speed 4-Channel MOSFET Driver with Two Inverting and Two Non-Inverting Outputs		
Package:	K6	=	16-lead (3x3) VQFN		
Environmental:	G	=	Lead (Pb)-free/RoHS-compliant Package		
Media Type:	(blank)	=	3300/Reel for a K6 Package		

**Example:**

a) MD1822K6-G: High-Speed 4-Channel MOSFET Driver with Two Inverting and Two Non-Inverting Outputs, 16-lead (3x3) VQFN, 3300/Reel

---

---

**Note the following details of the code protection feature on Microchip devices:**

- Microchip products meet the specification contained in their particular Microchip Data Sheet.
- Microchip believes that its family of products is one of the most secure families of its kind on the market today, when used in the intended manner and under normal conditions.
- There are dishonest and possibly illegal methods used to breach the code protection feature. All of these methods, to our knowledge, require using the Microchip products in a manner outside the operating specifications contained in Microchip's Data Sheets. Most likely, the person doing so is engaged in theft of intellectual property.
- Microchip is willing to work with the customer who is concerned about the integrity of their code.
- Neither Microchip nor any other semiconductor manufacturer can guarantee the security of their code. Code protection does not mean that we are guaranteeing the product as “unbreakable.”

Code protection is constantly evolving. We at Microchip are committed to continuously improving the code protection features of our products. Attempts to break Microchip's code protection feature may be a violation of the Digital Millennium Copyright Act. If such acts allow unauthorized access to your software or other copyrighted work, you may have a right to sue for relief under that Act.

---

Information contained in this publication regarding device applications and the like is provided only for your convenience and may be superseded by updates. It is your responsibility to ensure that your application meets with your specifications. MICROCHIP MAKES NO REPRESENTATIONS OR WARRANTIES OF ANY KIND WHETHER EXPRESS OR IMPLIED, WRITTEN OR ORAL, STATUTORY OR OTHERWISE, RELATED TO THE INFORMATION, INCLUDING BUT NOT LIMITED TO ITS CONDITION, QUALITY, PERFORMANCE, MERCHANTABILITY OR FITNESS FOR PURPOSE. Microchip disclaims all liability arising from this information and its use. Use of Microchip devices in life support and/or safety applications is entirely at the buyer's risk, and the buyer agrees to defend, indemnify and hold harmless Microchip from any and all damages, claims, suits, or expenses resulting from such use. No licenses are conveyed, implicitly or otherwise, under any Microchip intellectual property rights unless otherwise stated.

*Microchip received ISO/TS-16949:2009 certification for its worldwide headquarters, design and wafer fabrication facilities in Chandler and Tempe, Arizona; Gresham, Oregon and design centers in California and India. The Company's quality system processes and procedures are for its PIC® MCUs and dsPIC® DSCs, KEELOQ® code hopping devices, Serial EEPROMs, microperipherals, nonvolatile memory and analog products. In addition, Microchip's quality system for the design and manufacture of development systems is ISO 9001:2000 certified.*

**QUALITY MANAGEMENT SYSTEM  
CERTIFIED BY DNV  
= ISO/TS 16949 =**

### Trademarks

The Microchip name and logo, the Microchip logo, AnyRate, AVR, AVR logo, AVR Freaks, BitCloud, chipKIT, chipKIT logo, CryptoMemory, CryptoRF, dsPIC, FlashFlex, flexPWR, Heldo, JukeBlox, KeeLoq, Kleer, LANCheck, LINK MD, maXStylus, maXTouch, MediaLB, megaAVR, MOST, MOST logo, MPLAB, OptoLyzer, PIC, picoPower, PICSTART, PIC32 logo, Prochip Designer, QTouch, SAM-BA, SpyNIC, SST, SST Logo, SuperFlash, tinyAVR, UNI/O, and XMEGA are registered trademarks of Microchip Technology Incorporated in the U.S.A. and other countries.

ClockWorks, The Embedded Control Solutions Company, EtherSynch, Hyper Speed Control, HyperLight Load, IntellIMOS, mTouch, Precision Edge, and Quiet-Wire are registered trademarks of Microchip Technology Incorporated in the U.S.A.

Adjacent Key Suppression, AKS, Analog-for-the-Digital Age, Any Capacitor, AnyIn, AnyOut, BodyCom, CodeGuard, CryptoAuthentication, CryptoAutomotive, CryptoCompanion, CryptoController, dsPICDEM, dsPICDEM.net, Dynamic Average Matching, DAM, ECAN, EtherGREEN, In-Circuit Serial Programming, ICSP, INICnet, Inter-Chip Connectivity, JitterBlocker, KleerNet, KleerNet logo, memBrain, Mindi, MiWi, motorBench, MPASM, MPF, MPLAB Certified logo, MPLIB, MPLINK, MultiTRAK, NetDetach, Omniscient Code Generation, PICDEM, PICDEM.net, PICKit, PICtail, PowerSmart, PureSilicon, QMatrix, REAL ICE, Ripple Blocker, SAM-ICE, Serial Quad I/O, SMART-I.S., SQI, SuperSwitcher, SuperSwitcher II, Total Endurance, TSHARC, USBCheck, VariSense, ViewSpan, WiperLock, Wireless DNA, and ZENA are trademarks of Microchip Technology Incorporated in the U.S.A. and other countries.

SQTP is a service mark of Microchip Technology Incorporated in the U.S.A.

Silicon Storage Technology is a registered trademark of Microchip Technology Inc. in other countries.

GestIC is a registered trademark of Microchip Technology Germany II GmbH & Co. KG, a subsidiary of Microchip Technology Inc., in other countries.

All other trademarks mentioned herein are property of their respective companies.

© 2018, Microchip Technology Incorporated, All Rights Reserved.  
ISBN: 978-1-5224-3755-0



# MICROCHIP

## Worldwide Sales and Service

### AMERICAS

**Corporate Office**  
2355 West Chandler Blvd.  
Chandler, AZ 85224-6199  
Tel: 480-792-7200  
Fax: 480-792-7277  
Technical Support:  
<http://www.microchip.com/support>  
Web Address:  
[www.microchip.com](http://www.microchip.com)

#### Atlanta

Duluth, GA  
Tel: 678-957-9614  
Fax: 678-957-1455

#### Austin, TX

Tel: 512-257-3370

#### Boston

Westborough, MA  
Tel: 774-760-0087  
Fax: 774-760-0088

#### Chicago

Itasca, IL  
Tel: 630-285-0071  
Fax: 630-285-0075

#### Dallas

Addison, TX  
Tel: 972-818-7423  
Fax: 972-818-2924

#### Detroit

Novi, MI  
Tel: 248-848-4000

#### Houston, TX

Tel: 281-894-5983

#### Indianapolis

Noblesville, IN  
Tel: 317-773-8323  
Fax: 317-773-5453  
Tel: 317-536-2380

#### Los Angeles

Mission Viejo, CA  
Tel: 949-462-9523  
Fax: 949-462-9608  
Tel: 951-273-7800

#### Raleigh, NC

Tel: 919-844-7510

#### New York, NY

Tel: 631-435-6000

#### San Jose, CA

Tel: 408-735-9110  
Tel: 408-436-4270

#### Canada - Toronto

Tel: 905-695-1980  
Fax: 905-695-2078

### ASIA/PACIFIC

**Australia - Sydney**  
Tel: 61-2-9868-6733

**China - Beijing**  
Tel: 86-10-8569-7000

**China - Chengdu**  
Tel: 86-28-8665-5511

**China - Chongqing**  
Tel: 86-23-8980-9588

**China - Dongguan**  
Tel: 86-769-8702-9880

**China - Guangzhou**  
Tel: 86-20-8755-8029

**China - Hangzhou**  
Tel: 86-571-8792-8115

**China - Hong Kong SAR**  
Tel: 852-2943-5100

**China - Nanjing**  
Tel: 86-25-8473-2460

**China - Qingdao**  
Tel: 86-532-8502-7355

**China - Shanghai**  
Tel: 86-21-3326-8000

**China - Shenyang**  
Tel: 86-24-2334-2829

**China - Shenzhen**  
Tel: 86-755-8864-2200

**China - Suzhou**  
Tel: 86-186-6233-1526

**China - Wuhan**  
Tel: 86-27-5980-5300

**China - Xian**  
Tel: 86-29-8833-7252

**China - Xiamen**  
Tel: 86-592-2388138

**China - Zhuhai**  
Tel: 86-756-3210040

### ASIA/PACIFIC

**India - Bangalore**  
Tel: 91-80-3090-4444

**India - New Delhi**  
Tel: 91-11-4160-8631

**India - Pune**  
Tel: 91-20-4121-0141

**Japan - Osaka**  
Tel: 81-6-6152-7160

**Japan - Tokyo**  
Tel: 81-3-6880-3770

**Korea - Daegu**  
Tel: 82-53-744-4301

**Korea - Seoul**  
Tel: 82-2-554-7200

**Malaysia - Kuala Lumpur**  
Tel: 60-3-7651-7906

**Malaysia - Penang**  
Tel: 60-4-227-8870

**Philippines - Manila**  
Tel: 63-2-634-9065

**Singapore**  
Tel: 65-6334-8870

**Taiwan - Hsin Chu**  
Tel: 886-3-577-8366

**Taiwan - Kaohsiung**  
Tel: 886-7-213-7830

**Taiwan - Taipei**  
Tel: 886-2-2508-8600

**Thailand - Bangkok**  
Tel: 66-2-694-1351

**Vietnam - Ho Chi Minh**  
Tel: 84-28-5448-2100

### EUROPE

**Austria - Wels**  
Tel: 43-7242-2244-39  
Fax: 43-7242-2244-393

**Denmark - Copenhagen**  
Tel: 45-4450-2828  
Fax: 45-4485-2829

**Finland - Espoo**  
Tel: 358-9-4520-820

**France - Paris**  
Tel: 33-1-69-53-63-20  
Fax: 33-1-69-30-90-79

**Germany - Garching**  
Tel: 49-8931-9700

**Germany - Haan**  
Tel: 49-2129-3766400

**Germany - Heilbronn**  
Tel: 49-7131-67-3636

**Germany - Karlsruhe**  
Tel: 49-721-625370

**Germany - Munich**  
Tel: 49-89-627-144-0  
Fax: 49-89-627-144-44

**Germany - Rosenheim**  
Tel: 49-8031-354-560

**Israel - Ra'anana**  
Tel: 972-9-744-7705

**Italy - Milan**  
Tel: 39-0331-742611  
Fax: 39-0331-466781

**Italy - Padova**  
Tel: 39-049-7625286

**Netherlands - Drunen**  
Tel: 31-416-690399  
Fax: 31-416-690340

**Norway - Trondheim**  
Tel: 47-7288-4388

**Poland - Warsaw**  
Tel: 48-22-3325737

**Romania - Bucharest**  
Tel: 40-21-407-87-50

**Spain - Madrid**  
Tel: 34-91-708-08-90  
Fax: 34-91-708-08-91

**Sweden - Gothenberg**  
Tel: 46-31-704-60-40

**Sweden - Stockholm**  
Tel: 46-8-5090-4654

**UK - Wokingham**  
Tel: 44-118-921-5800  
Fax: 44-118-921-5820

## Looking for pricing, stock, or lifecycle information?

Click below to explore more details on WIN SOURCE:

- ⊖ [View MD1822K6-G on WIN SOURCE](#)
- ⊖ [Microchip Technology Information](#)

## Optimize Your Supply Chain with WIN SOURCE Solutions

- ✓ Global Sourcing Solution
- ✓ Obsolete Management
- ✓ Cost Control Management
- ✓ Shortage Management
- ✓ Alternative Solution
- ✓ Excess Inventory Management